

ID-A234 578

PL-TR-91-3014

AD:

2



Special Report
for the period
May 1990 to
August 1990

**Parametric Studies of Dense Plasma
Focus for Fusion Space Propulsion
with D - He³**

DTIC
SELECTE
APR 16 1991
c D

March 1991

Author:
C.L. Leakeas

Approved for Public Release

Distribution is unlimited. The OL-AC PL Technical Services Office has reviewed this report and it is releasable to the National Technical Information Service, where it will be available to the general public, including foreign nationals.

Phillips Laboratory (AFSC)
Air Force Systems Command
Edwards AFB CA 93523-5000

100-100-100-100

91 4 15 130

NOTICE

When U.S. Government drawings, specifications, or other data are used for any purpose other than a definitely related Government procurement operation, the fact that the Government may have formulated, furnished, or in any way supplied the said drawings, specifications, or other data, is not to be regarded by implication or otherwise, or in any way licensing the holder or any other person or corporation, or conveying any rights or permission to manufacture, use or sell any patented invention that may be related thereto.

FOREWORD

This final report was submitted on completion of a special project under In-House JON: 305800J5 at the OL-AC, Phillips Laboratory (AFSC) (formerly Astronautics Laboratory), Edwards AFB CA 93523-5000. OL-AC PL Project Manager was Dr Frank Mead.

This report has been reviewed and is approved for release and distribution in accordance with the distribution statement on the cover and on the DD Form 1473.



FRANKLIN B. MEAD
Project Manager

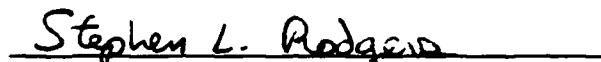

STEPHEN L. RODGERS
Chief, Emerging Technologies Branch

FOR THE COMMANDER



DAVID W. LEWIS, MAJ, USAF
Director
Fundamental Technologies Division

REPORT DOCUMENTATION PAGE

Form Approved
OMB No. 0704-0188

1a. REPORT SECURITY CLASSIFICATION UNCLASSIFIED			1b. RESTRICTIVE MARKINGS			
2a. SECURITY CLASSIFICATION AUTHORITY			3. DISTRIBUTION / AVAILABILITY OF REPORT Approved for Public Release; Distribution is Unlimited			
2b. DECLASSIFICATION / DOWNGRADING SCHEDULE						
4. PERFORMING ORGANIZATION REPORT NUMBER(S) PL-TR-91-3014			5. MONITORING ORGANIZATION REPORT NUMBER(S)			
6a. NAME OF PERFORMING ORGANIZATION Phillips Laboratory (AFSC)		6b. OFFICE SYMBOL (if applicable)	7a. NAME OF MONITORING ORGANIZATION			
6c. ADDRESS (City, State, and ZIP Code) OL-AC PL/RKFE Edwards AFB CA 93523-5000			7b. ADDRESS (City, State, and ZIP Code)			
8a. NAME OF FUNDING / SPONSORING ORGANIZATION		8b. OFFICE SYMBOL (if applicable)	9. PROCUREMENT INSTRUMENT IDENTIFICATION NUMBER			
8c. ADDRESS (City, State, and ZIP Code)			10. SOURCE OF FUNDING NUMBERS			
			PROGRAM ELEMENT NO. 62302F	PROJECT NO. 3058	TASK NO. 00J5	WORK UNIT ACCESSION NO. 344725
11. TITLE (Include Security Classification) Parametric Studies of Dense Plasma Focus for Fusion Space Propulsion with D - He ³ (U)						
12. PERSONAL AUTHOR(S) Leakeas, Christopher L.						
13a. TYPE OF REPORT Special		13b. TIME COVERED FROM 9005 TO 9008		14. DATE OF REPORT (Year, Month, Day) 9103		15. PAGE COUNT 50
16. SUPPLEMENTARY NOTATION OL-AC PL was formerly known as the Astronautics Laboratory (AFSC). COSATI CODE: 20/09						
17. COSATI CODES			18. SUBJECT TERMS (Continue on reverse if necessary and identify by block number) Fusion propulsion, space propulsion, dense plasma focus, advanced fusion fuels, D- ³ He fuel cycle, aneutronic fusion			
FIELD	GROUP	SUB-GROUP				
18	01					
20	08					
19. ABSTRACT (Continue on reverse if necessary and identify by block number) A coaxial electrode system known as the dense plasma focus (DPF) is investigated as a possible space propulsion concept. A large potential difference between the electrodes ionizes the gaseous fusion fuel and forms an annular plasma sheath. This sheath then propagates down the length of the anode entraining additional fuel along the way. The "rundown" phase is analyzed by solving the momentum equation using this snowplow model. At the end of the anode, MHD instabilities cause the sheath to collapse into a hot, high density plasma where fusion events occur. Fusion reaction products as well as unreacted fuel can then be used to produce thrust. It is also possible to use the reaction products to heat hydrogen propellant in order to produce more thrust. An open-ended coolant cycle may be used in order to avoid the necessity for large radiators. In this way, the heated coolant can be used to drive a turbogenerator to produce electricity before it is exhausted as propellant. A model of the DPF is developed, various operating regimes are identified, and key parameters varied to define optimum operating ranges. Computations were made with the FORTRAN code found in the appendix. Operation with no hydrogen propellant allows high specific impulse (I _{sp}) values, about 10 ⁶ s, possible with thrusts of about 44.5 N (10 lbf). (OVER)						
20. DISTRIBUTION / AVAILABILITY OF ABSTRACT <input checked="" type="checkbox"/> UNCLASSIFIED/UNLIMITED <input type="checkbox"/> SAME AS RPT. <input type="checkbox"/> DTIC USERS			21. ABSTRACT SECURITY CLASSIFICATION UNCLASSIFIED			
22a. NAME OF RESPONSIBLE INDIVIDUAL Dr Franklin B. Mead			22b. TELEPHONE (Include Area Code) (805) 275-5540		22c. OFFICE SYMBOL OL-AC PL/RKFE	

PL-TR-91-3014

Block 19 (continued)

Continuous pulsed operation at around 1,600 MW while exhausting hydrogen propellant, heated by the fusion process, can allow I_{sp} 's of 10^4 s at thrust levels around 17,800 N (4,000 lbf). Impulsive thrusting at 3,200 MW with large propellant mass flow rates can allow I_{sp} 's of about 3,000 s at 111,250 N (25,000 lbf). These high I_{sp} 's make larger mission delta V's possible and can decrease trip time and reduce exposure of astronauts to cosmic radiation.

TABLE OF CONTENTS

	PAGE
ABSTRACT	1
INTRODUCTION	2
PLASMA DYNAMICS	3
DPF COMBUSTOR MODEL	7
DPF PROPULSION SYSTEM MODEL	12
CONCLUSIONS AND RECOMMENDATIONS	29
REFERENCES	30

Accession For	
NTIS GRA&I	<input checked="" type="checkbox"/>
DTIC TAB	<input type="checkbox"/>
Unannounced	<input type="checkbox"/>
Justification	
By	
Distribution/	
Availability Codes	
Dist	Avail and/or Special
A-1	

LIST OF FIGURES

FIGURE		PAGE
1	Coaxial Electrode Configuration	4
2	Phases of the DPF Cycle	6
3	Reaction Rate Parameters for Various Fuels	10
4	Plasma Focus Fusion Propulsion System	13
5	Axial Variation of Fluid Variables for a Quasi-1D Meridional Magnetic Nozzle	17
6	Plasma Pinch Temperature vs. Current	19
7	Propellant Temperature vs. Current	20
8	Specific Impulse vs. Current	22
9	Initial Thrust-to-Weight Ratio vs. Current for various fractions of particles trapped in the pinch	23
10	Initial Thrust-to-Weight Ratio vs. Current for various capacitor specific energies	24
11	Initial Thrust-to-Weight Ratio vs. Firing Time for various currents	25
12	Maximum Mission Velocity Increment vs. Payload Mass Fraction	27

LIST OF TABLES

TABLE		PAGE
1	Ranges of Typical Performance Parameters for Several Different Rocket Engine Types	2
2	Assumed Plasma Focus Parameters	9

ABSTRACT

A coaxial electrode system known as the dense plasma focus (DPF) is investigated as a possible space propulsion concept. A large potential difference between the electrodes ionizes the gaseous fusion fuel and forms an annular plasma sheath. This sheath then propagates down the length of the anode entraining additional fuel along the way. The "rundown" phase is analyzed by solving the momentum equation using this snowplow model. At the end of the anode, MHD instabilities cause the sheath to collapse into a hot, high density plasma where fusion events occur. Fusion reaction products as well as unreacted fuel can then be used to produce thrust. It is also possible to use the reaction products to heat hydrogen propellant in order to produce more thrust. An open-ended coolant cycle may be used in order to avoid the necessity for large radiators. In this way, the heated coolant can be used to drive a turbogenerator to produce electricity before it is exhausted as propellant.

A model of the DPF is developed, various operating regimes are identified, and key parameters varied to define optimum operating ranges. Computations were made with the FORTRAN code found in the appendix. Operation with no hydrogen propellant allows high specific impulse (I_{sp}) values, about 10^6 s, possible at thrusts of about 44.5 N (10 lbf). Continuous pulsed operation at around 1,600 MW while exhausting hydrogen propellant, heated by the fusion process, can allow I_{sp} 's of 10^4 s at thrust levels around 17,800 N (4,000 lbf). Impulsive thrusting at 3,200 MW with large propellant mass flow rates can allow I_{sp} 's of about 3,000 s at 111,250 N (25,000 lbf). These high I_{sp} 's make larger mission ΔV 's possible and can decrease trip time and reduce exposure of astronauts to cosmic radiation.

INTRODUCTION

The plasma focus was first discovered and investigated in the 1960's as a power reactor, but was then put aside in favor of other concepts. Since then it has mainly been used as a laboratory source of neutrons and x-rays. It is now being investigated by the Air Force for its potential as a fusion propulsion concept.

In this paper, I will attempt to examine the behavior of the DPF as a propulsion concept while investigating key parameters and defining optimum operating conditions. Since little work has been done on this topic, it is necessary to make some initial simplifying assumptions involving plasma pinch dynamics as well as heat transfer.

Fusion propulsion has long been considered a desirable alternative to other propulsion scenarios currently available, viz. chemical and nuclear thermal. Table I gives a comparison of some key parameters for these scenarios.

TABLE I
Ranges of Typical Performance Parameters for
Several Different Rocket Engine Types

Propulsion Concept	Specific Impulse I_{sp} (sec)	System Thrust-to- Weight Ratio, F/W
Chemical (liquid)	300 to 460	0.01 to 100
Chemical (solid)	200 to 310	0.01 to 100
Nuclear Fission	600 to 1,100	0.01 to 30
Nuclear Fusion	3,000 to 25,000	10^{-3} to > 1 (?)

A key point in the design of any propulsion system is the attainable thrust-to-weight ratio. Extrapolation of current results seems to show that fusion systems may be capable of thrust-to-weight ratios equal to or larger than one. Most fusion propulsion concepts are plagued with the problem of very high system masses. They require large components with heavy particle injection systems and huge superconducting magnets. Any advantage gained by the release of large amounts of energy is therefore negated by the high system mass which seems to be unavoidable in most fusion systems. However, because the DPF is very small it reduces total system mass to a level where it may be able to produce acceptable values of thrust-to-weight ratio. In this paper I will derive some of the equations which govern the operation of the DPF and investigate its potential uses for space propulsion.

PLASMA DYNAMICS

The DPF is a system of coaxial electrodes which allows the formation and subsequent propagation of a thin plasma sheath in the annular region between the center anode and the outer cathode. When the sheath reaches the end of the anode, magnetohydrodynamic (MHD) instabilities develop and the sheath disconnects from the cathode and collapses toward the axis forming a very small region of high density, hot plasma. It is here where fusion reactions take place and generate the energy to be used for propulsion.

The DPF is similar in geometry to the magnetoplasmadynamic (MPD) thruster⁽¹⁾ currently used in electric propulsion but differs greatly in its operation. The DPF typically will use currents which are about 1,000 times greater, and unlike the MPD does not currently operate in the steady-state mode. The MPD forms a stable sheath near the end of the electrode system and makes no use of a rundown phase which occurs in the DPF. However, the key distinction between the two devices is that the MPD makes no attempt to use the tremendous amounts of energy available from fusion. It is here that the DPF gains an advantage over most propulsion concepts. For example, the fusion of deuterium (D) and helium-3 (³He) can release almost five times more energy per unit mass than the fissioning of a uranium-235 nucleus.

In the DPF, the plasma sheath is initially created when a large current is discharged through the center anode. The resulting potential difference causes the current to arc across to the cathode. In the process, the fill gas (fusion fuel) is ionized and forms an azimuthally symmetric plasma sheath in the annular region between the electrodes. The current flowing through the anode also produces an azimuthal magnetic field, B_θ , which interacts with the plasma sheath current. This results in the propagation of the sheath down the length of the anode due to the $J_r \times B_\theta$ force. Figure 1 shows the cylindrical thruster configuration as well as the directions of the current, magnetic field, and sheath propagation. During "rundown", some fraction of the fill gas is entrained in the sheath and carried down to the end of the anode. As the sheath reaches the end of the anode, MHD instabilities cause it to break off from the cathode and collapse or "focus" toward the axis of the device, forming a high density ($\approx 10^{26} \text{ m}^{-3}$), hot plasma where fusion reactions may take place. This number density may change depending on the fraction of initial fuel which is trapped in the pinch region. This fraction is left as an independent variable during thruster evaluation, but is assumed to be about 17.5% for the baseline case. This value is arrived at by assuming that about 70% of all fuel is entrained during rundown, and of that, 25% is captured in the pinch.

The pinched plasma expands and contracts several times before it eventually becomes completely disrupted by plasma instabilities. It is particularly susceptible to the $m=0$ "sausage" and $m=1$ "kink"

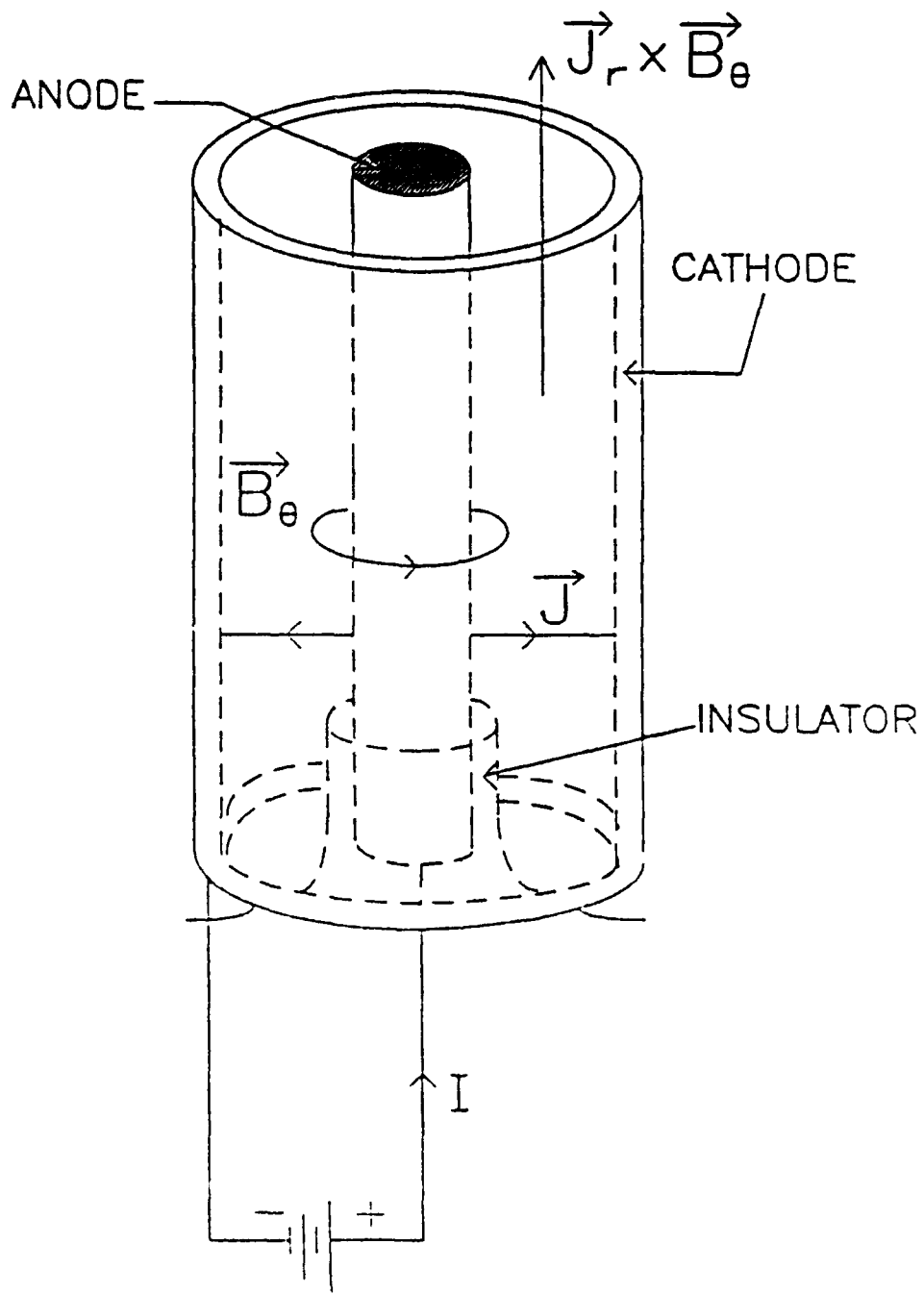

Figure 1
Coaxial Electrode Configuration

instabilities. Figure 2 gives a graphic representation of the different phases which occur during one cycle of the DPF. This pinch lifetime is typically very short, on the order of a microsecond⁽²⁾. However, if the pinch lifetime can be made sufficiently long to allow a good fusion burn inside the pinch, the DPF can provide enough energy to propel spacecraft at high thrust, high specific impulse, or both. While the rundown can be predicted with reasonable accuracy, the collapse and subsequent plasma behavior are not well understood and are in great need of further study.

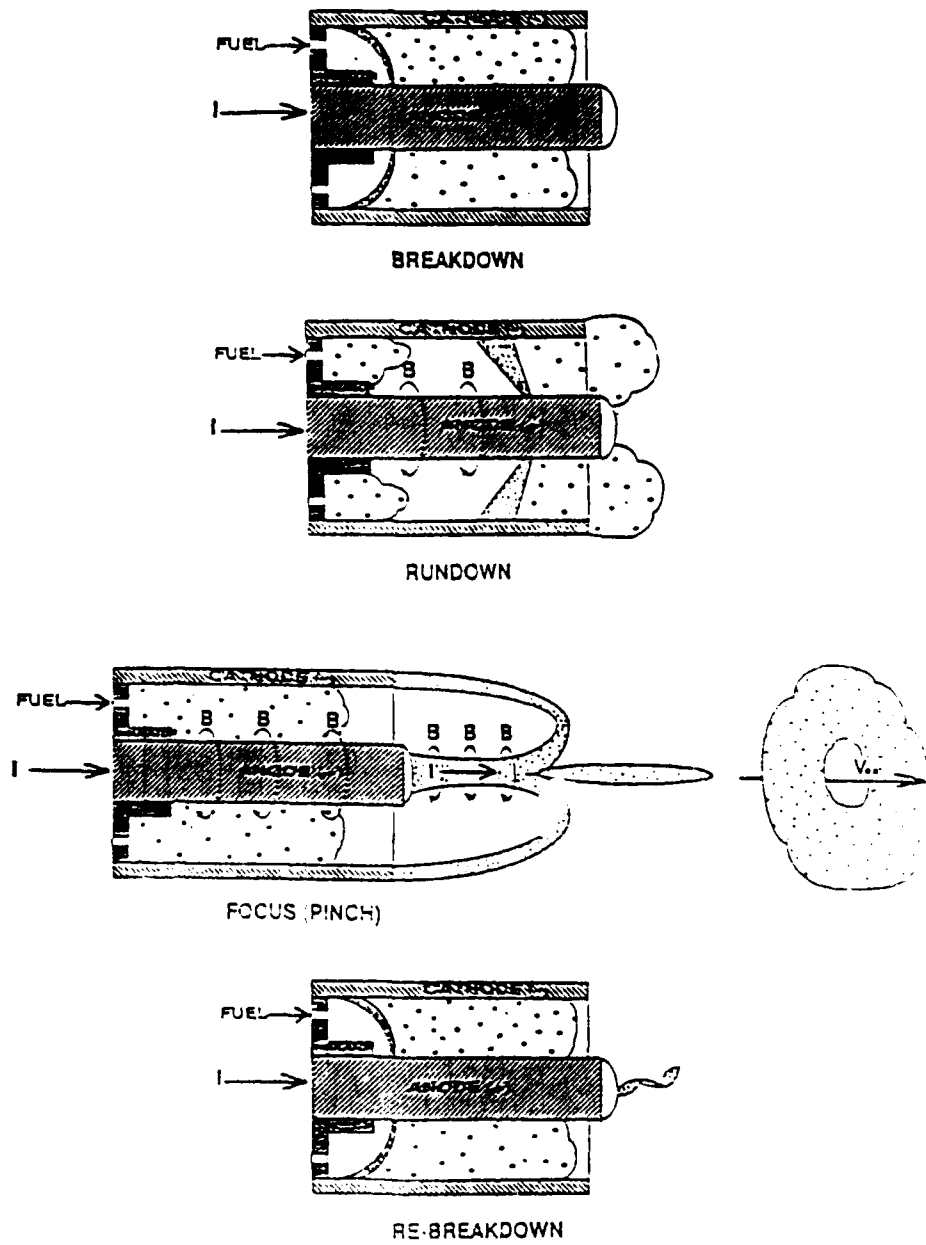

Figure 2
Phases of the DPF Cycle

DPF COMBUSTOR MODEL

The rundown velocity, U_{run} , can be predicted accurately by solving the steady-state momentum equation for the plasma sheath neglecting dissipative effects, starting with⁽³⁾

$$\rho_1 \nabla \cdot (\mathbf{U}_{run} \mathbf{U}_{run}) = -\nabla p \quad (1)$$

then taking only z-components and integrating gives

$$U_{run} = \sqrt{\frac{\mu_0}{8\pi^2 r_a^2 \rho_1}} I \quad (2)$$

where I is the current discharged through the anode, r_a is the radius of the anode and ρ_1 is the initial fill gas density. The sheath then reaches the end of the anode and collapses forming a small, hot plasma. (It will be shown later that the final temperature depends on many factors including the capacitor discharge current. Also, the pinch dimensions are assumed to be independent of operating conditions.) If we assume that a fraction f of particles go into the pinch, and make a rough estimate of the dimensions of the resulting pinch formation, we can determine the number density of particles inside the pinch. To determine the temperature inside the pinch, we assume a balance between plasma pressure and the magnetic pressure due to the external azimuthal field, B_θ , generated by the current in the pinch, as in Eq. 3.

$$n_p kT = \frac{B_\theta^2}{2\mu_0} \quad (3)$$

where kT is the product of Boltzmann's constant and the plasma temperature (in degrees) and μ_0 is the permeability of free space. By Ampere's Law, B_θ at the pinch surface is

$$B_\theta = \frac{\mu_0 I}{2\pi r_p} \quad (4)$$

Solving for the pinch number density, n_p , in terms of the initial fill density and pinch and electrode dimensions, we find

$$n_p = \frac{f \rho_1 l_a (r_c^2 - r_a^2)}{l_p r_p^2 m_p} \quad (5)$$

where l_a and l_p are the anode and pinch lengths and r_a , r_c , and r_p are the anode, cathode, and pinch radii respectively, and m_p is the average mass of particles in the pinch. Substituting Eqns. 4 and 5 into Eqn. 3 gives an expression for the plasma temperature inside the pinch.

$$kT = \frac{\mu_0 I^2 m_p l_p}{8\pi^2 f \rho_l l_a (r_c^2 - r_a^2)} \quad (6)$$

This gives the plasma temperature for any current I . The maximum attainable current must now be calculated as a function of the electrical parameters of the system (eg. capacitance, inductance, charging voltage, etc.). The maximum attainable current is given by

$$I_{\max} = 0.64 \left(\frac{WI}{L} \right)^{1/3} \quad (7)$$

where

$$W = \frac{1}{2} CV^2 \quad (8)$$

$$I = \frac{V}{L_0} \quad (9)$$

$$L = \frac{\mu_0}{2\pi} U_{\text{run}} \ln \left(\frac{r_c}{r_a} \right) \quad (10)$$

where C is the total capacitance, V is the charging potential, and L_0 is the initial circuit inductance⁽⁴⁾. Thus, from the initial conditions defined in Eqs. 8-10, the maximum current and resulting plasma pinch temperature can be found with Eqs. 6 and 7. It is assumed through the rest of this paper that the plasma pinch temperature continues to scale as current squared as shown in Eqn. 6 and Figure 6, although this scaling seems to fail for currents above 1 MA due to saturation and degradation effects⁽⁵⁾.

The plasma focus device analyzed in this report is assumed to be identical to the "Livermore I" dense plasma focus. Therefore I have used the same geometrical and electrical parameters which were used in the operation of this device⁽³⁾. The parameters used can be found in Table II where asterisks denote assumed values. If operated at the values in Table II, the Livermore I focus should be capable of a maximum current of 1.245 MA and a maximum plasma temperature of about 300 eV. This plasma temperature is much too low to produce significant amounts of fusion energy. As seen in

Figure 3, one would ideally operate at kT greater than about 50 keV (depending on the fuel) in order to maximize the reaction rate parameter. I will therefore assume that the capacitor banks to be used are capable of delivering in excess of 20 MA.

Using the values in Table II, the DPF's performance can be modeled for a wide range of currents using the simple scaling laws found in Eqs. 4-6. A computer code which calculates important propulsion performance parameters given the initial DPF parameters can be found in the appendix.

TABLE II
Assumed plasma focus parameters

$V = 27,000 \text{ V}$	$C = 3.55 \times 10^{-4} \text{ F}$
$L_0 = 2.5 \times 10^{-8} \text{ H}$	$l_a = 0.382 \text{ m}$
$r_a = 0.0508 \text{ m}$	$r_c = 0.080 \text{ m}$
* $F = 0.175$	* $l_p = 0.0254 \text{ m}$
* $r_p = 0.0015 \text{ m}$	$\rho_1 = 2.2 \times 10^{-4} \text{ kg/m}^3$

To complete the development of the DPF model, the fusion fuels need to be defined. There are several desirable criteria to be considered in the choice of fusion fuels.

The fusion fuels should have a high power density. Of all the fusion reactions being considered today, the D-³He reaction has the highest power density at 18.3 MeV per reaction. D-T is second at 17.6 MeV, ³He-³He releases 12.9 MeV, and p-¹¹B releases 8.7 MeV per reaction.

The fuel should have a high reaction rate parameter at low temperature to achieve good fusion burn before radiative losses overwhelm the system. The reaction rate parameter, $\langle \sigma v \rangle$, is a function of plasma temperature and determines how quickly these reactions proceed at a given temperature. Figure 3 shows the reaction rate parameters for some typical fusion fuels⁽⁶⁾. D-T has the highest reaction rate parameter at low temperatures and the D-³He reaction rate parameter is slightly less. The other "advanced" fuels⁽⁷⁾ such as p-⁶Li, p-¹¹B, and ³He-³He must be operated at very high temperatures⁽⁸⁾ and may be impractical because cyclotron radiation losses increase in proportion to the electron temperature squared, making ignition difficult. The D-D reaction has a reaction rate parameter which is slightly less than that for D-T, but this fuel has two major disadvantages. It has a much lower power density (about 4 MeV) and has a 50% probability of producing a neutron with each reaction.

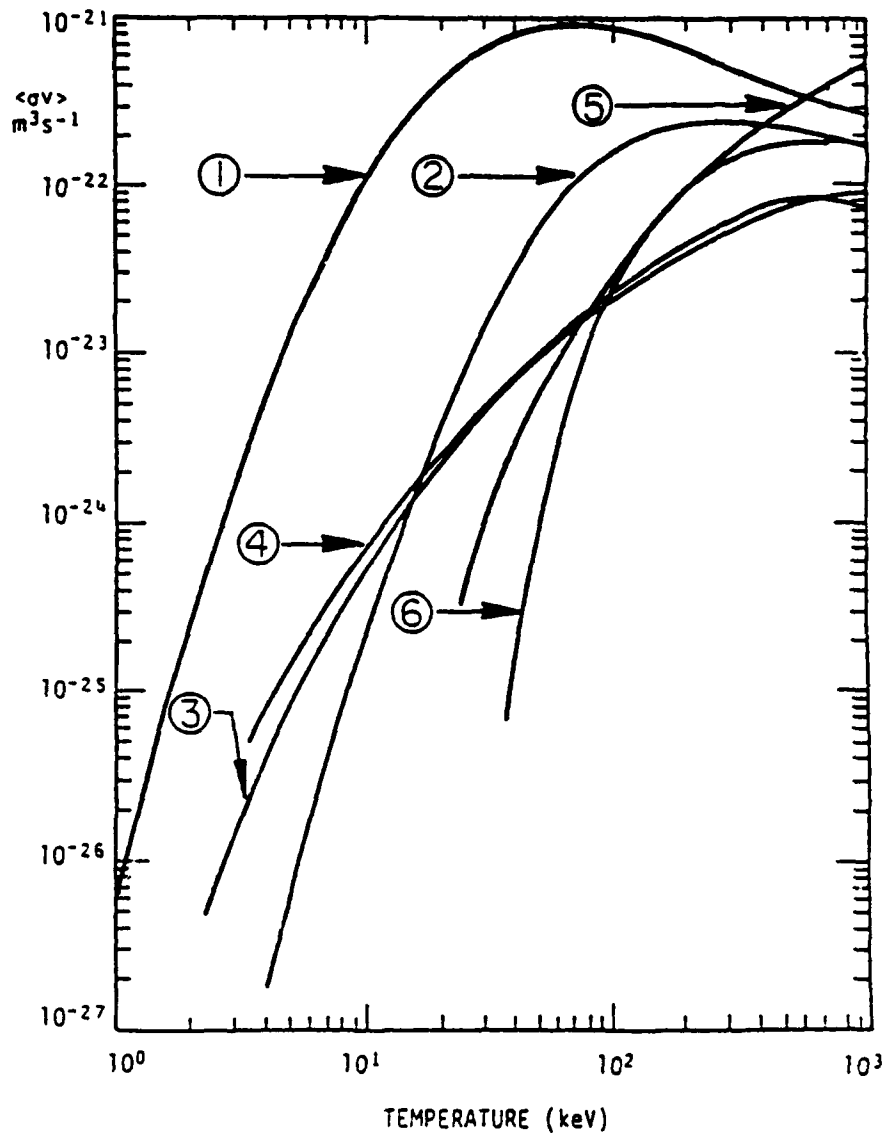

Figure 3

Reaction Rate Parameters for Various Fuels
 (1) D-T, (2) D- ^3He , (3) D-D
 (4) T-T, (5) T- ^3He , (6) p- ^{11}B

Since neutrons cannot be directed to produce thrust by a magnetic field, it is desirable to minimize their production. An ideal reaction would release all of its energy in the form of charged particles. Of the "easily" ignitable fuels, D-T releases about 80% of its energy as neutrons, while the D-³He reaction releases no neutrons. However, the background D-D reaction, which releases about 75% of its energy in neutron radiation, can contribute significant neutron production to the D-³He reaction. The other fuels are considered to be completely aneutronic.

After considering each fuels' characteristics in these three areas, D-³He was chosen as the fuel to be used in this DPF study. Its leaner neutron production (compared to D-T), high power density and high reaction rate parameter at relatively low temperatures were key factors in its selection.

DPF PROPULSION SYSTEM MODEL

The DPF fusion propulsion system (see Figure 4) consists of the feed and cooling system, the electrical power system and the thruster system. The feed and cooling system consists of three tanks for the hydrogen, helium-3, and deuterium, associated plumbing to control and direct the flow of these gases, and the associated coolant passages. Also necessary in this system are a number of pumps to drive propellant and fuel flow, as well as to provide the pressure necessary for the coolant to enter the high pressure side of the turbine. The deuterium and helium-3 are used as the fuel to drive the thruster. The hydrogen is used for cooling, driving the turbine, and may then also be used as propellant to provide increased thrust.

The electrical system consists of a turbine, electric generator and the capacitor banks necessary to produce the large current pulses which are required by the thruster. The electricity produced by the turbo-generator is used to meet system requirements and to help recharge the capacitor banks for the each shot.

The thruster system consists of the DPF itself as well as a mixing chamber and a magnetic nozzle if one chooses to operate the DPF at very high propellant temperatures. As will be seen later, the magnets necessary for our purpose are relatively small and constitute a small fraction of total system mass. The mixing chamber is only necessary if the DPF propulsion system is to be operated with hydrogen propellant. It is a hollow cylindrical cavity where the fusion reaction products will mix with cold hydrogen propellant. It is assumed that the resulting mixture leaves the chamber with a uniform temperature and produces thrust.

The exhaust power produced in any type of rocket engine is given by

$$P_{ex} = \frac{1}{2} F \cdot U_{ex} \quad (11)$$

where F is the thrust and U_{ex} is the propellant exhaust velocity. If one assumes that the thrust is parallel to the exhaust velocity and defines the specific impulse by

$$I_{sp} = \frac{U_{ex}}{g} \quad (12)$$

and the thrust by

$$F = \dot{m}_{propellant} U_{ex} \quad (13)$$

PLASMA FOCUS FUSION PROPULSION SYSTEM

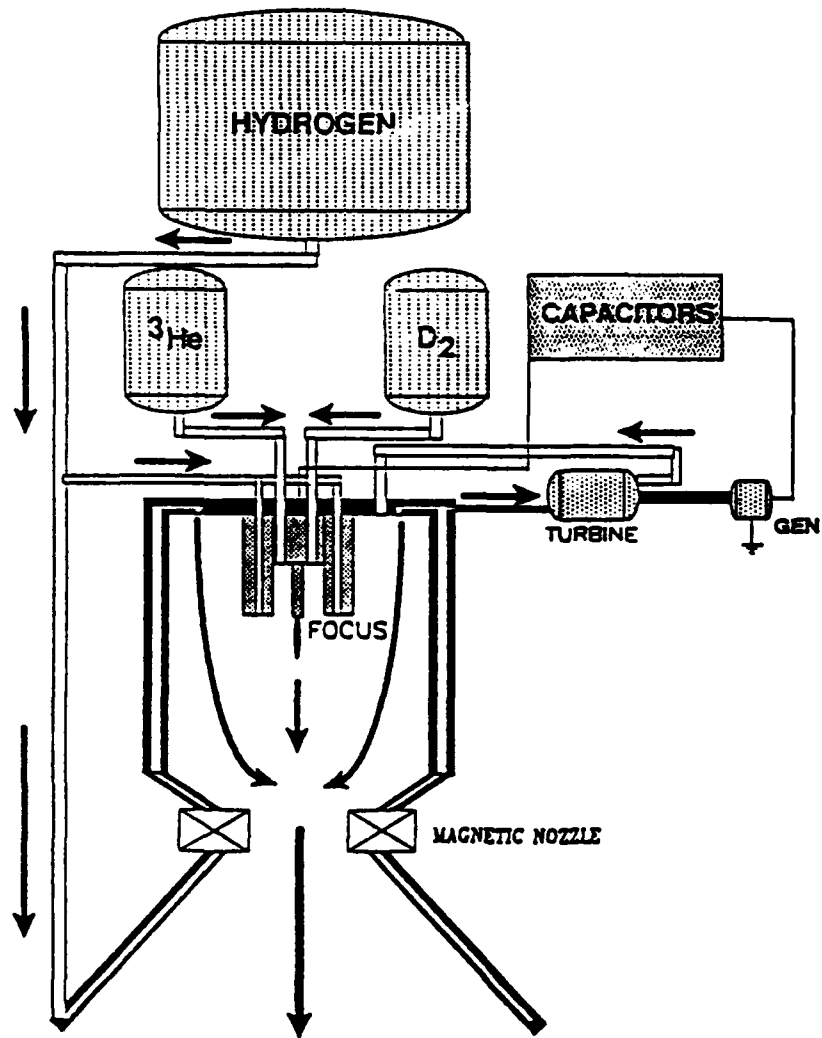

Figure 4

Plasma Focus Fusion Propulsion System

The exhaust power can then be written as

$$P_{ex} = \frac{1}{2} g F I_{sp} \quad (14)$$

where g is the gravitational acceleration and specific impulse is a measure of how efficiently propellant is used⁽⁹⁾. Eqn. 14 shows the competing nature of thrust and specific impulse. Both are desirable, but for a fixed engine power an increase in one requires a decrease in the other. However, with the high exhaust powers attainable with fusion, it should be possible to attain reasonably high values of both parameters simultaneously.

Three possible modes of operation for the DPF propulsion system were investigated:

- 1) Pulsed operation of the DPF for long periods of time with no hydrogen propellant exhausted. The fusion products are produced and immediately expelled to produce thrust. The total time that the thruster is fired is comparable to the total trip time.
- 2) Pulsed operation of the DPF for long periods of time with the addition of moderate quantities of hydrogen propellant. The hydrogen is used to provide electric power and also provides additional thrust because of increased mass flow rate in the exhaust with some loss of I_{sp} .
- 3) Pulsed operation of the DPF for short periods of time during which large quantities of hydrogen are exhausted in a high thrust, impulsive burn. This "impulsive" burn reduces gravitational losses, makes much higher thrust-to-weight ratios possible and would most likely be used during interplanetary travel.

Mode 1) Pulsed operation with no hydrogen propellant

This mode involves a closed coolant cycle and would therefore require large radiators (0.07 kg/kWe)⁽¹⁰⁾ to dissipate the heat produced by resistive heating of the electrodes and radiative power losses in the thruster walls. It is still possible to generate electricity from the turbo-generator before the coolant enters the radiators. The calculations made for this mode are identical to those made using the FORTRAN code in the appendix of this report, except that one must include the radiator mass and use a zero propellant mass flow rate. The system is similar to that shown in

Figure 4, but with the addition of radiators in the coolant loop and removal of the mixing chamber.

When the fusion fuels react in the pinch, it is assumed that very little charged particle power is retained in the pinch. Thus, when the charged particles leave the pinch, their energies are known simply as a function of the fusion fuels used (D-³He produces 14.7 MeV protons and 3.6 MeV alpha particles). The velocities of these particles are very high (some over 10⁷ m/s). These velocities lead to specific impulse values on the order of 10⁶ s. However, because of the low mass flow rate exiting the pinch, thrust values are on the order of about 44.5 N (10 lbf), and the main contribution to this thrust comes from the expulsion of fill gases which are not trapped during the rundown and pinch phase of operation. For a manned Mars mission with a payload dominating mass of 10⁵ kg⁽¹¹⁾, the system thrust-to-weight ratio (F/W) upper bound is about 5.0x10⁻⁵. If the additional mass of radiators, shielding, capacitors, tanks, fuel, etc. are considered, F/W decreases further. This F/W value is many orders of magnitude less than conventional chemical rockets. In this mode, the DPF is comparable in performance to electric propulsion. Although these thrust levels have applications to certain types of missions (perhaps orbital transfer), manned interplanetary travel requires larger mission ΔV 's and shorter trip times to reduce exposure to cosmic radiation and weightlessness. Therefore this mode was not considered beyond the conceptual stage.

Mode 2) Pulsed operation with hydrogen propellant

One way to increase F/W values is by exhausting the heated coolant to increase the mass flow rate and corresponding thrust given in Eq. 13. In doing this we accept the penalty of decreased specific impulse as a necessary means to increase thrust. The increase in thrust will allow the DPF's use in a wide variety of missions, whereas operating without hydrogen propellant restricts the type of missions for which it can be used.

The Mode 2 system is illustrated schematically in Figure 4. As the capacitor banks are being discharged through the center anode, the fuel is injected and is caught up in the plasma sheath's rundown as illustrated in Figure 2. The plasma collapses and pinches at the end of the anode and produces large amounts of charged fusion products as well as Bremsstrahlung and cyclotron radiation and neutrons. It was assumed that the Bremsstrahlung radiation, which is emitted in the UV spectrum is completely lost. However, part of the cyclotron radiation was assumed to be absorbed by the plasma and part absorbed in the walls of the electrodes and mixing chamber. The portion absorbed in the walls and electrodes was assumed to be about 20% for the baseline case, but was left as a variable parameter to observe its effects on thruster

performance. The heat generated by cyclotron radiation and ohmic heating is then cooled by the flow of cold liquid hydrogen propellant. Because of material limitations, the turbine entrance temperature was constrained to be no greater than 2,000 K. This would require advances in material sciences since current materials restrict temperatures to less than about 1,100 K⁽¹²⁾. This inlet temperature constraint then fixes the minimum mass flow rate of coolant which enters the mixing chamber. The gas is then expanded through a turbine used to run a generator which recharges the capacitor bank. Complete recharging of the capacitors is only possible at higher powers and larger coolant flow rates. The flow from the turbine is then used as propellant to absorb the energy of the charged particles produced in the pinch. An open cycle was chosen to avoid heavy radiators that would greatly increase total system mass. The propellant was assumed to absorb all of the fusion product energy after accounting for radiative losses and become completely dissociated and ionized in the mixing chamber. The resulting propellant plasma was assumed to come to a uniform temperature before it enters a meridional magnetic nozzle (axial field only). The magnetic nozzle (see Figure 5), which would require a maximum field of about 2 T⁽¹³⁾, then further accelerates the particles out the exit to even higher velocities.

In doing the analysis, several simplifying assumptions were made. These assumptions concerned aspects of the pinch as well as advancements in other technologies applicable to the DPF. These assumptions are:

- 1) Plasma pinch temperature scales as current squared.
- 2) Since no accurate measurements of actual pinch dimensions have been made, a rough estimate was used.
- 3) Ions come to thermal equilibrium inside the pinch allowing the use of Maxwellian reaction rate parameters.
- 4) Materials will be developed that can withstand temperatures much higher than currently possible. This would be necessary in the turbine and in the walls of the mixing chamber to minimize damages due to high heat fluxes.
- 5) Electrodes and mixing chamber walls can be sufficiently cooled to prevent damage. Film cooling may be possible, but at the cost of I_{sp} .
- 6) Propellant becomes completely dissociated and ionized in the mixing chamber at 5,000 K.
- 7) Advances in capacitor bank technology will increase specific energies by a factor of 10 and allow for

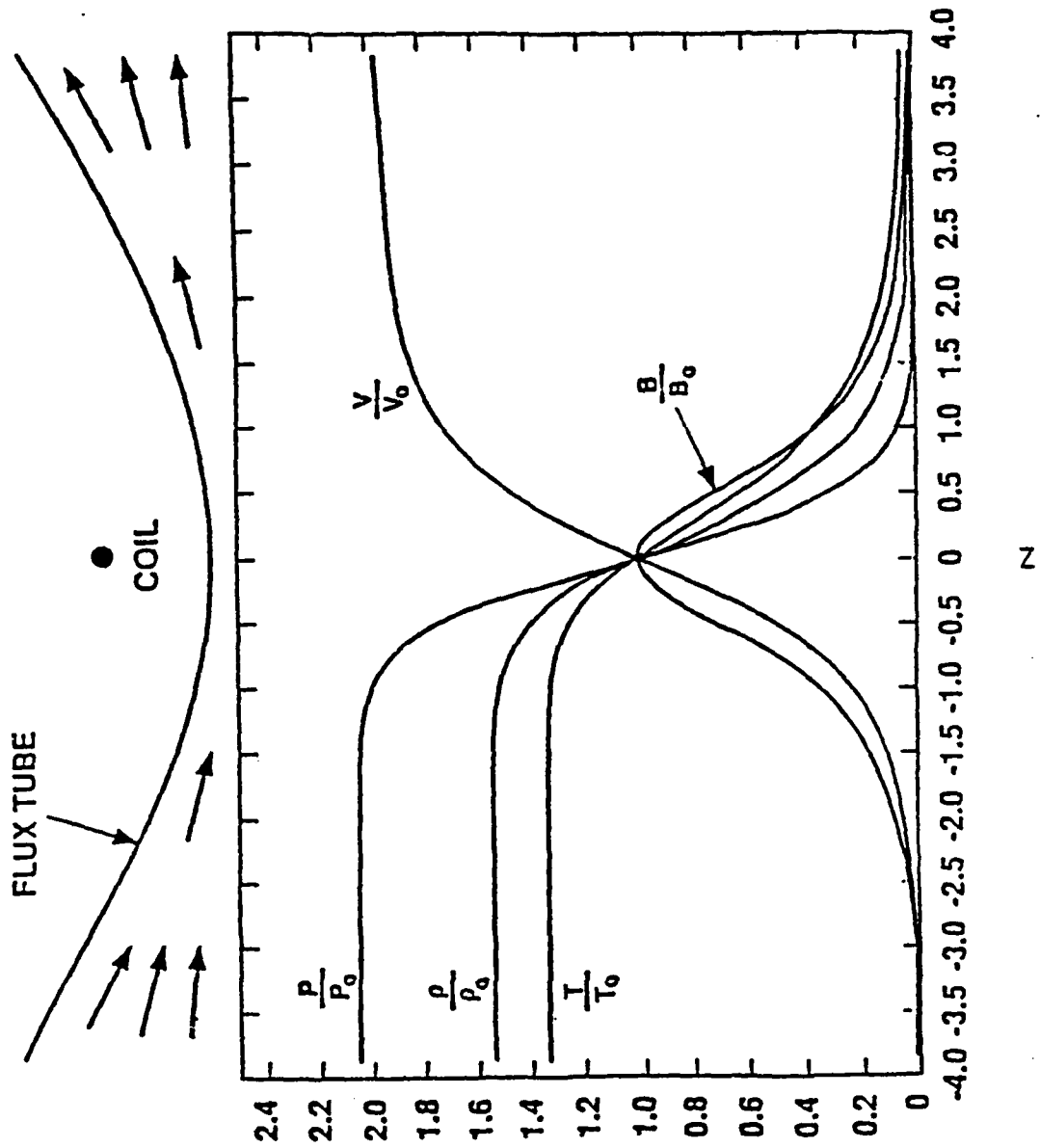

Figure 5

Axial Variation of Fluid Variables for a quasi-1D Meridional Magnetic Nozzle

discharging rates of 100 Hz. Capacitors based on present technology offer a specific masses of about 0.2 kJ/kg⁽¹⁴⁾.

- 8) Confinement times can be increased about a hundred times (to about 10^{-4} s) to allow for a good fusion burn (around 40%). Since reaction rates are determined by plasma temperature, longer confinement times allow for more fuel to be burned.
- 9) Any magnetic fields applied downstream do not adversely affect the pinch formation or confinement time.

With these assumptions, thruster performance was investigated while varying current, fraction of particles trapped in pinch, capacitor bank specific energy, total firing time, and fraction of cyclotron radiation absorbed in walls and electrodes.

Baseline case:

f = Fraction of particles trapped in pinch	0.175
FRACT = % cyclotron radiation absorbed in walls and electrodes	0.20
SPECEN = Capacitor bank specific energy	2.0 kJ/kg
DAYS = Total thruster firing time	30 days

For the cases of continuous pulsed operation (Modes 1 and 2), DAYS is defined as the length of time which the thruster is fired. The baseline case assumes that the thruster is fired for 30 days and that this is comparable to total trip time.

Figure 6 shows the pinch temperature dependence on current for several values of **f**, the fraction of particles trapped in the pinch. Using the assumed pinch dimensions and initial fill gas density, **f** = 0.175 gave pinch number densities which are close to experimentally determined values ($n \geq 10^{19}$ cm⁻³)⁽¹²⁾. Although lower **f** gives lower pinch number density, Figure 6 shows lower **f** also gives higher plasma temperature. Operating at the very high temperatures necessary to ignite some advanced fuels, such as ³He-³He and p-¹¹B, may not be feasible since cyclotron radiation increases as T^2 .

Figure 7 shows the resulting propellant temperature at the entrance to the magnetic nozzle as a function of current for various values of **f**. As current is increased past a certain point, the extra fusion power produced cannot continue to raise the temperature of the increased coolant (and therefore propellant) flow which must be supplied due to greater heat flux to the walls and electrodes. Therefore, this function does not increase indefinitely, but has a definite maximum at about 15 MA for

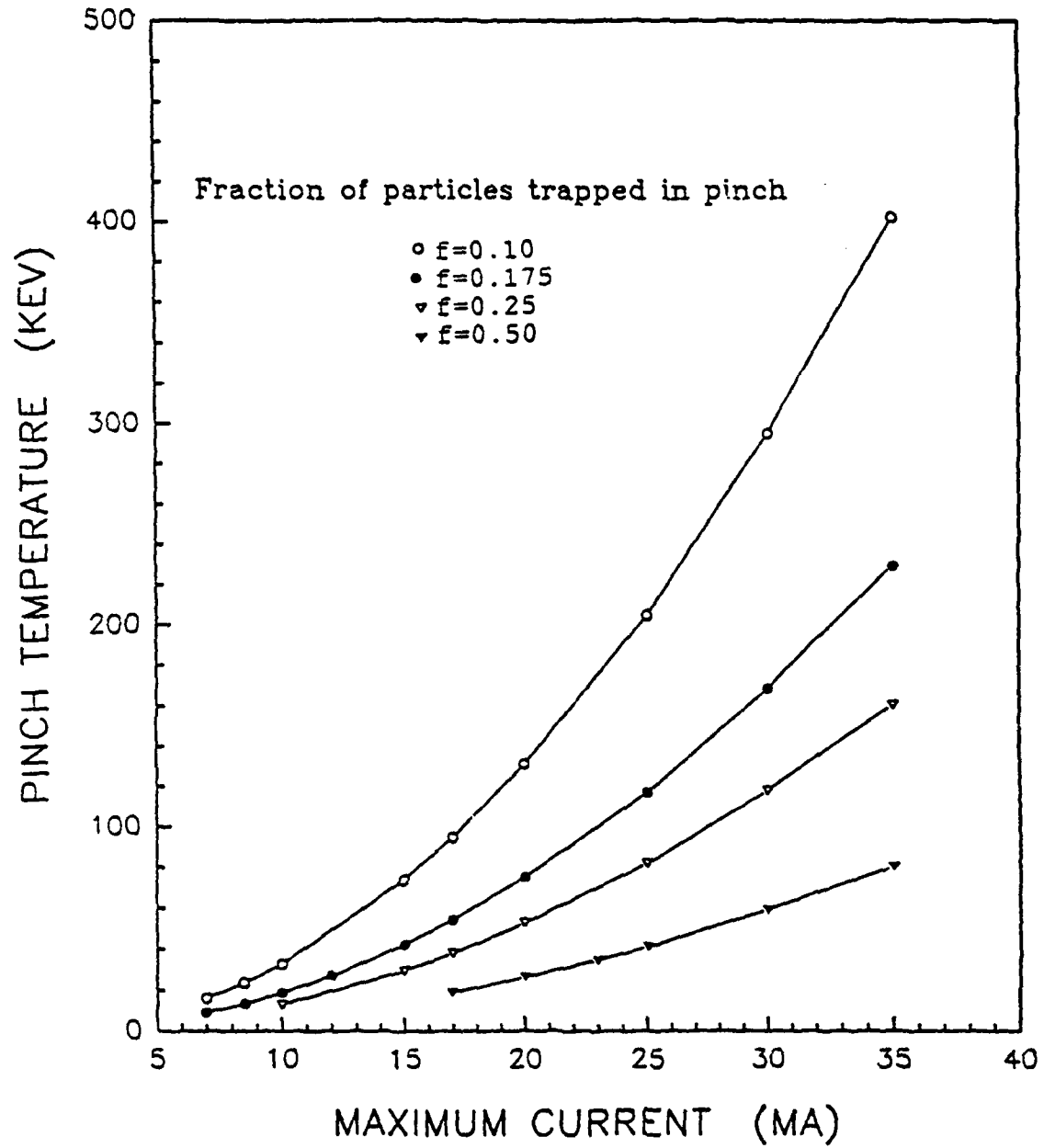

Figure 6

Plasma Pinch Temperature vs. Current

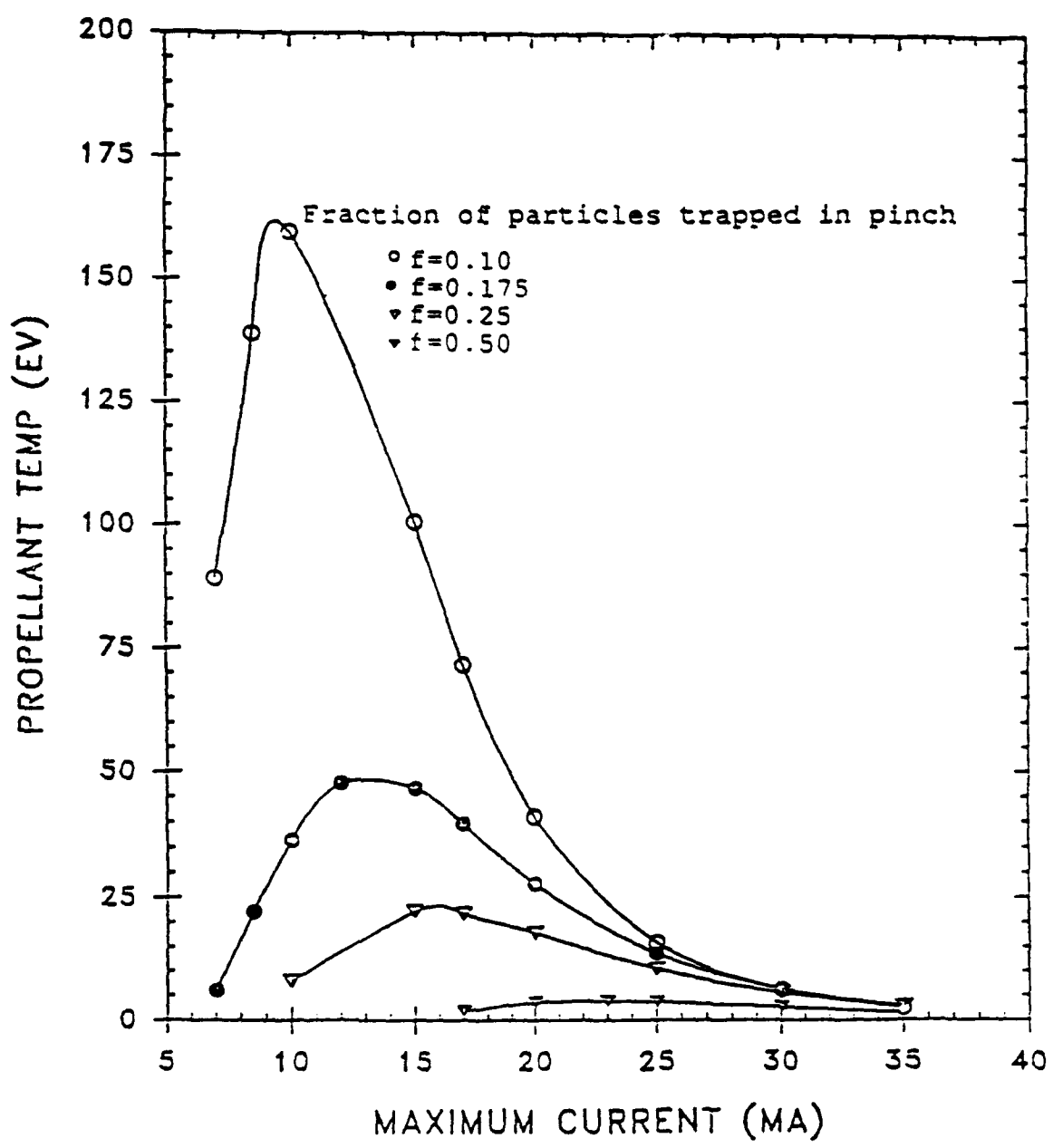

Figure 7
 Propellant Temperature vs. Current

baseline values of f and **FRACT**. This corresponds to the maximum in specific impulse for the baseline case in Figure 8. As f increases, the number density in the pinch increases, so the resulting pinch temperature decreases: the reaction rate decreases because of the lowered temperature, and there is less fusion output to heat the propellant. A balance is established between plasma and magnetic pressures, so for higher values of f , and therefore particle density, a higher current is required to bring the plasma temperature up to its maximum. As the maximum current, I_{max} , increases, the propellant mass flow must correspondingly increase to cool electrodes of the focus device. Figure 9 shows that the current which maximizes specific impulse (about 15 MA for the baseline case in Figure 8), also produces a maximum F/W for the baseline case. As current is increased beyond this optimum, capacitor mass and required coolant mass increase resulting in a decrease in thrust-to-weight ratio. System F/W ratios are calculated by the program in the appendix taking into account all system masses. As seen in Figure 9, vehicle F/W peaks at about 15 MA and reaches almost 0.003 for the baseline case, while a typical value for a manned Mars mission using an impulsive burn is about 0.200. This would seem to be the optimum operating regime for the DPF in this mode operating at baseline conditions, as it maximizes both specific impulse and F/W.

Another problem is in the area of capacitor bank technology. Modern capacitors allow a specific energy of about 0.2 kJ/kg⁽¹⁴⁾. However, to supply the necessary currents to the thruster and magnet, these specific energies would require capacitor masses on the order of 40,000 kg (about 40% of the assumed payload for a manned Mars mission). Advancements in capacitor technology might allow specific energies of 2.0 kJ/kg and would make the total system mass much smaller and allow higher thrust-to-weight ratios (see Figure 10). Further increases over 2.0 kJ/kg change thrust-to-weight ratios only slightly because at high specific energies system mass is dominated by propellant and payload.

The final parameter was the total firing time. Figure 11 shows the expected decrease in F/W as firing time increases because of the increase in propellant mass which must be carried. Once again, the maximum value seems to occur at about 15 MA. Although thrust is increased, the problem with continuous operation is apparent. In this high I_{sp} , low F/W mode, mission times become extremely long and thrust-to-weight values drop even further, giving the DPF limited usefulness for interplanetary travel.

Mode 3) Impulsive firing with hydrogen propellant

The plasma focus propulsion system can also be operated by firing for a short period of time while exhausting great quantities of propellant at higher exhaust powers. In this way, the propellant has been exhausted and is no longer considered to contribute to the total system mass. This decreased system mass allows larger

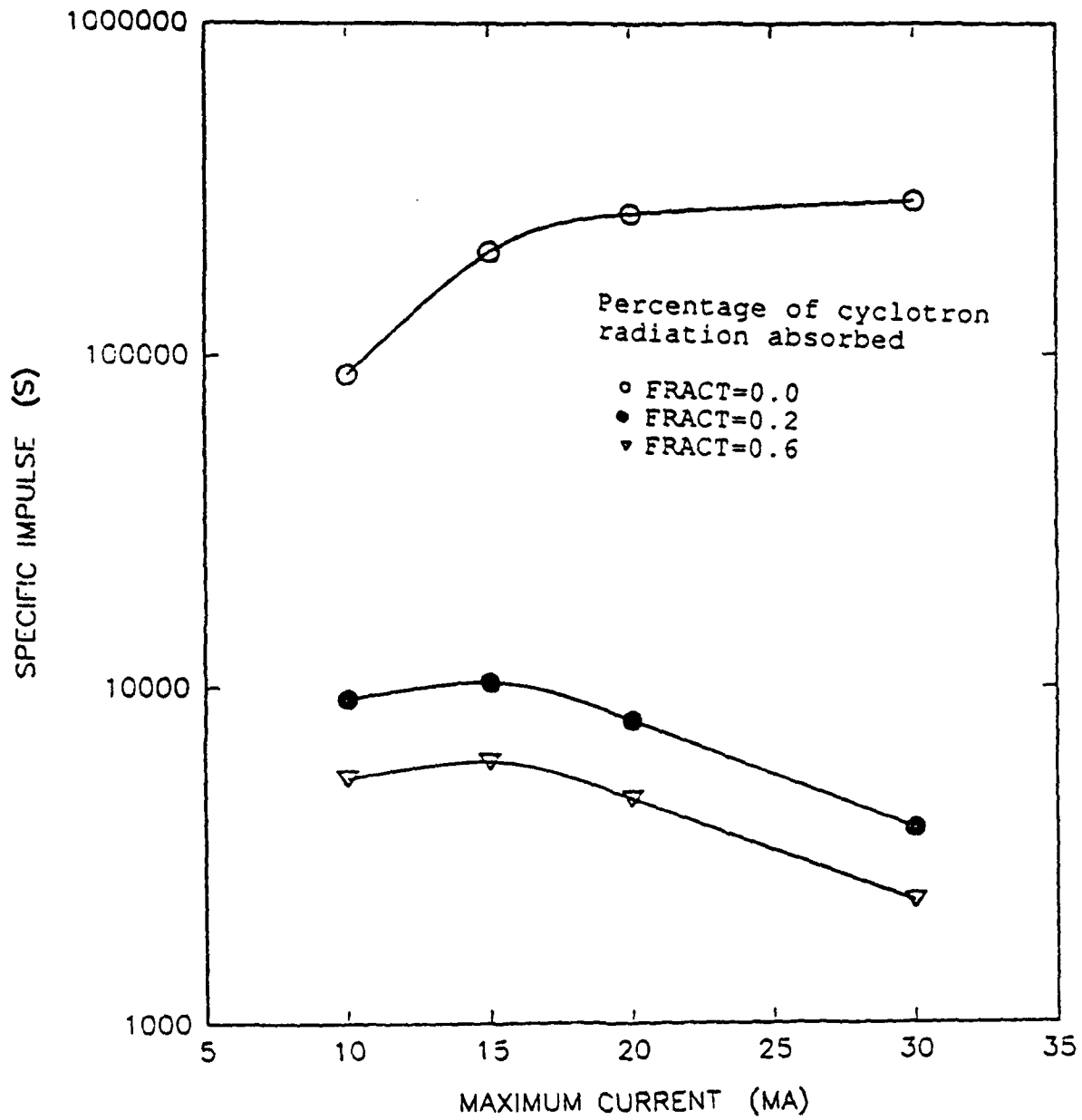

Figure 8
Specific Impulse vs. Current

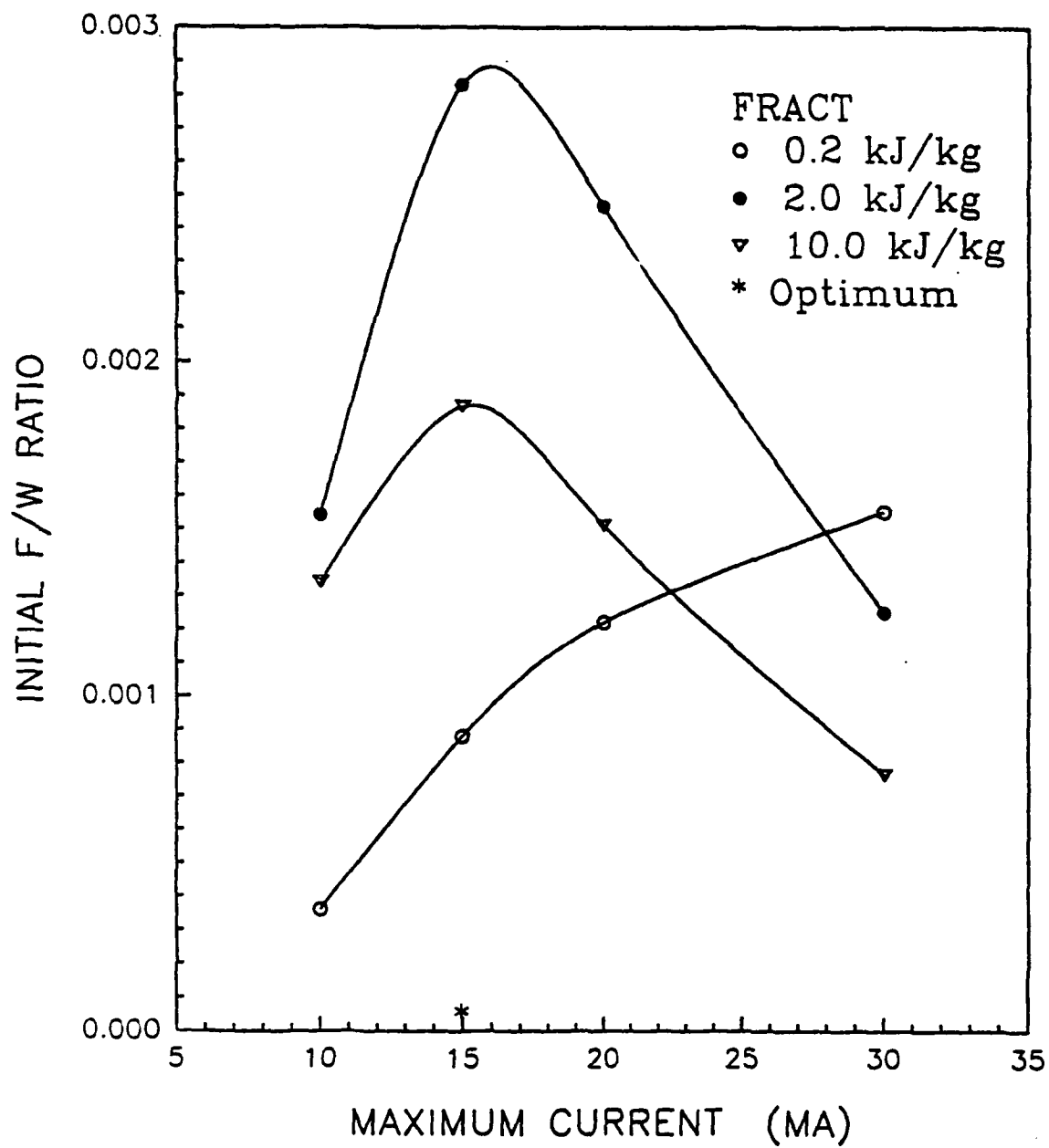

Figure 9
Thrust-to-Weight Ratio vs. Current

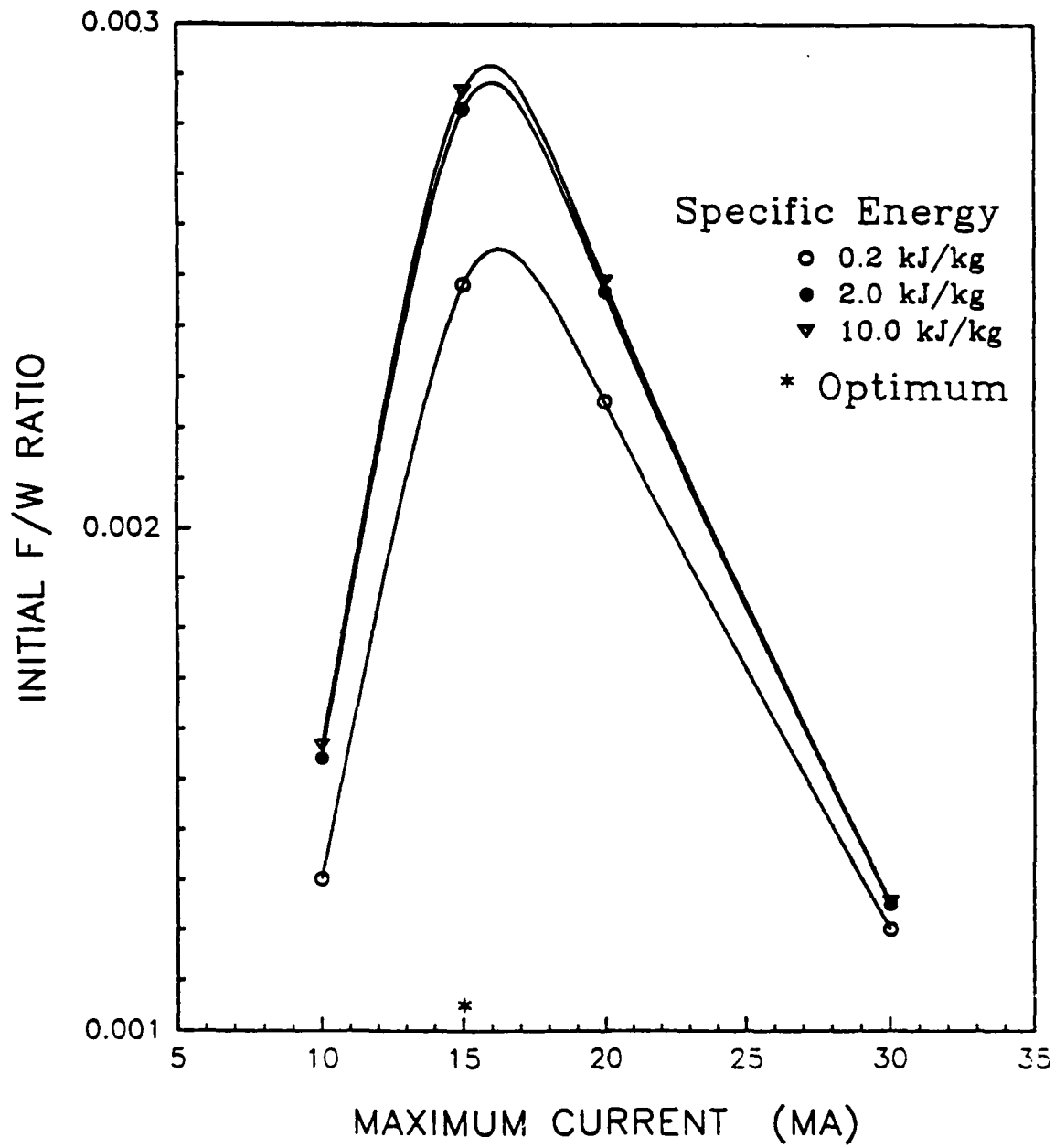

Figure 10
Thrust-to-Weight Ratio vs. Current

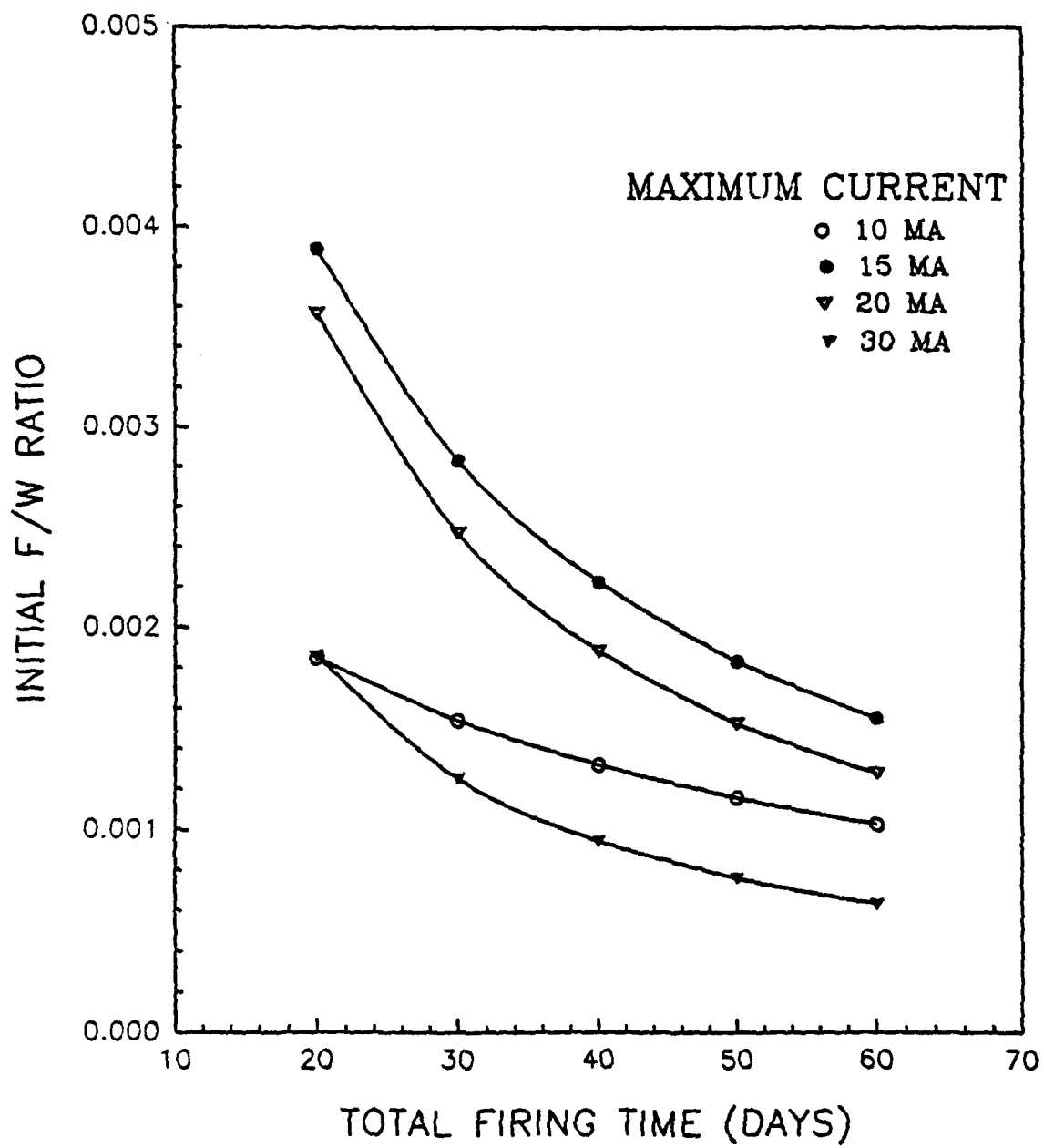

Figure 11
Thrust-to-Weight Ratio vs. Firing Time

acceleration for the same thrust resulting in larger F/W ratios. These higher F/W ratios decrease the required ΔV for a given mission resulting in a decrease in trip time. This increase in mass flow rate greatly increases thrust, but at the expense of I_{sp} . This operating regime seems to be the most likely candidate for interplanetary space travel, and a preliminary study is included in this report. By adding additional hydrogen flow to the coolant flow and increasing the power output by raising the current, F/W ratios can be increased by a factor of ten over the DPF propulsion system operated in the continuous mode while exhausting hydrogen propellant (Mode 2). The DPF thruster is limited by how much exhaust power it can produce. However, by increasing the current we can increase the fusion output, and thus the exhaust power; what remains is to heat additional propellant to tailor the thrust and specific impulse for the mission (see Eqs. 11-14). One must avoid raising the capacitor current past a point where material damage may be done to the electrodes and mixing chamber. Figure 12 shows the total ΔV capability of the DPF as a function of payload mass fraction at $I_{sp}=3,500$ s and 111,250 N (25,000 lbf) of thrust. These numbers were obtained from the program in the appendix, where the DPF was operated at $I_{ex}=25$ MA at a power of 3200 MW. The curve in Figure 12 can be found from the rocket equation:

$$\frac{M_f}{M_i} = e^{-\frac{\Delta V}{u_{ex}}} \quad (15)$$

Where M_i is the initial mass (total system mass, payload and propellant) and M_f is the final mass after the burn (total system mass and payload only). The rocket equation can be simplified to

$$\Delta V_{capable} = g I_{sp} \ln \left(\frac{M_i}{M_f} \right) \quad (16)$$

Because of the possibility for high I_{sp} , the plasma focus is clearly capable of high ΔV 's and quick trip times if adequate thrust-to-weight values can be attained. Typical vehicle thrust-to-weight ratios for a chemical rocket on a manned Mars mission are on the order of 0.2. At 25 MA with a total propellant mass flow rate of 4 kg/s, the plasma focus propulsion system is capable of attaining system thrust-to-weight ratios of around 0.027. These values seem to change very little as propellant mass flow rate (and therefore I_{sp}) is changed; for instance, at an I_{sp} of 5,560 seconds and a thrust of 66,750 N (15,000 lbf), the system F/W is 0.025. Although this is lower than 0.2, its corresponding high I_{sp} could make the DPF propulsion system useful for various types of low ΔV missions. Vehicle F/W is a strong function of required mission ΔV since this determines the amount of propellant which is necessary and therefore initial total system mass for a fixed payload. Further investigation of this mode of operation is currently being done to determine if the DPF propulsion system is capable of

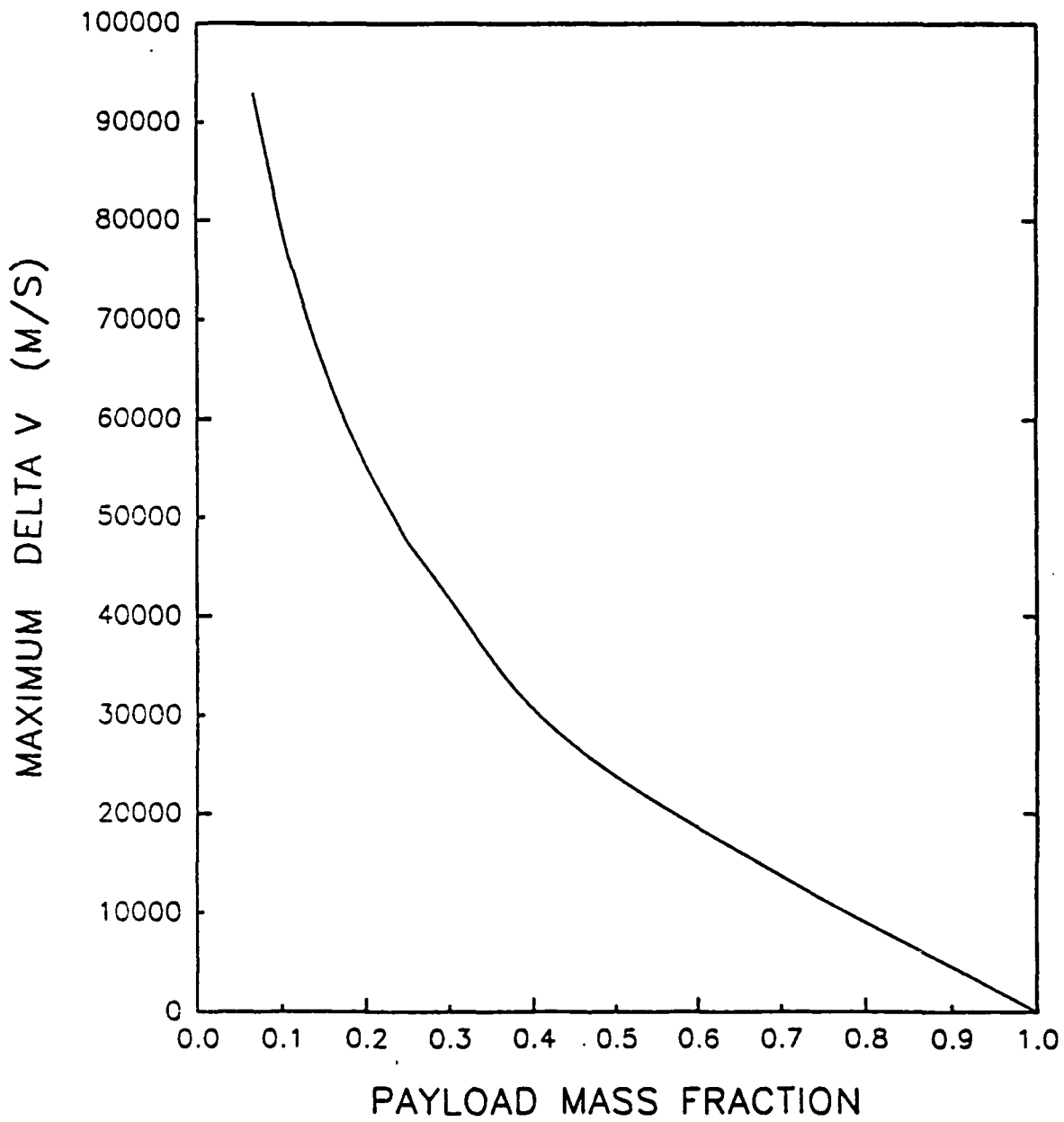

Figure 12
 ΔV Capability vs. Payload Mass Fraction

producing F/W ratios useful in interplanetary travel. Preliminary results show that F/W ratios can be greatly improved by increasing thruster power and propellant mass flow rate and that the DPF propulsion system can be competitive with chemical and nuclear fission rockets in F/W while maintaining higher I_{sp} .

These calculations are very sensitive to the assumed dimensions of the pinch. Since the fusion power depends on the plasma volume, any error in the estimation of pinch dimensions may greatly understate the amount of fusion power produced. This will in turn affect both thrust and I_{sp} . Caution should be taken when "using" these numbers in the realization that final results can depend greatly on assumed initial parameters.

CONCLUSIONS AND RECOMMENDATIONS

If scaling holds, the dense plasma focus could be a relatively easy way of obtaining hot, high density plasmas. Further study of the dynamics of the pinching process and of the eventual disruption of the pinch due to MHD instabilities is necessary. Trapping a strong axial magnetic field inside the pinch may stabilize it by reducing the rate at which the instabilities grow. Accurate measurements of pinch dimensions is critical in the computation of important propulsion parameters.

Of the three modes of operation discussed, impulsive operation with hydrogen propellant seems to be the most likely scenario in any interplanetary travel using the DPF. Right now, none of the three modes produces F/W ratios which are compatible with those necessary for distant space missions. However, preliminary studies indicate that the impulsive mode operated at very high exhaust power and large propellant mass flow rates should allow high specific impulses while attaining F/W levels necessary for interplanetary space travel. The other two modes of operation seem to be limited in their applications because increasing exhaust power greatly increases the amount of propellant mass, thus decreasing F/W. These modes have their optimum operating regimes at F/W ratios which may have potential for use in low ΔV missions such as orbital transfer or perhaps a lunar shuttle.

In addition to its potential uses as a propulsion device, the DPF can also be used as a laboratory source of x-rays and high energy ions useful in studies of fundamental physics. If confinement time can be improved, the DPF could also become practical as a small fusion power reactor when coupled with a direct energy converter. Other advanced fuels which are lean in neutrons such as p - ${}^6\text{Li}$, p - ${}^{11}\text{B}$, and ${}^3\text{He}$ - ${}^3\text{He}$ should also be investigated for their usefulness as fusion fuels, although cyclotron losses could make ignition a challenge.

Further study of the use of impulsive burns for distant missions is being carried out at the Astronautics Lab, and the possibility of using more than one DPF to increase thrust levels for both continuous and impulsive burns should also be investigated.

REFERENCES

1. Jahn, R.G., Physics of Electric Propulsion, McGraw Hill, NY, 1968.
2. Lovberg, R.H., and Griem, H.R., Methods of Experimental Physics, Academic Press, NY, 1971, p. 187.
3. Eltgroth, P.G., "Comparison of Plasma Focus Calculations", Physics of Fluids, v. 14, pp. 1911-1924, Sept. 1982.
4. Dolan, T.J., Fusion Research, Volume II, Pergamon Press, NY, 1982, p. 313.
5. Herold, H., Jerzykiewicz, A., Sadowski, S., and Schmidt, H., "Comparative Analysis of Large Plasma Focus Experiments Performed at IPF, Stuttgart, and at IPC, Swierk", Nuclear Fusion, 29, (1989) p. 1255.
6. Dolan, T.J., Fusion Research, Volume I, Pergamon Press, NY, 1982, pp. 54-56.
7. Cox, L.T., "Thermonuclear Reaction Bibliography with Cross Section Data for Four Advanced Reactions", AFAL-TR-89-006 (March 1989).
8. Cox, L.T., "The Barn Book", AL-TR-90-053 (publication pending).
9. Sutton, G.P., Rocket Propulsion Elements, McGraw Hill, 3rd Edition.
10. Cerbone, R. (Brookhaven), personal conversations, July 1990.
11. Dave Perkins (AL), personal conversations, July 1990.
12. Farner, K., "SSME System Modelling Code", NASA Marshall Technical Report, 1987.
13. Gerwin, R.A., Marklin, G.J., Sgro, A.G., and Glasser, A.H., "Characterization of Plasma Flows Through Magnetic Nozzles", AL-TR-89-092 (February 1990).
14. Haloulakos, V.E., and Borque, R.F., "Fusion Propulsion Study", McDonnell Douglas Corporation, Huntington Beach, CA, AL-TR-89-005 (July 1989), p. 62.

C
C *****
C *****
C ***** THE DENSE PLASMA FOCUS : A FUSION PROPULSION SCENARIO *****
C *****
C *****
C *****

C PROGRAMMER : CHRISTOPHER L. LEAKEAS
C SCHOOL OF NUCLEAR ENGINEERING
C PURDUE UNIVERSITY
C WEST LAFAYETTE, IN 47907

C WRITTEN AT : ASTRONAUTICS LABORATORY
C AL (AFSC) /LSVF
C EDWARDS AFB, CA 93523-5000

C
C THIS PROGRAM WILL CALCULATE THE PARAMETERS NECESSARY IN THE OPERATION
C OF A DENSE PLASMA FOCUS FOR USE AS A SPACE THRUSTER.

C THRUST TO WEIGHTS FROM THIS PROGRAM ARE ONLY VALID FOR
C CONTINUOUS PULSING MODE WHEN A TOTAL FIRING TIME IS ENTERED.
C ALL OTHER PARAMETERS ARE VALID FOR ALL MODES OF OPERATION.
C THRUST TO WEIGHT FOR IMPULSIVE MISSIONS CAN BE OBTAINED BY
C USING THRUST AND ISP VALUES FROM THIS PROGRAM AND USING THE
C ROCKET EQUATION FOR A GIVEN DELTAV TO GET THE PAYLOAD MASS
C FRACTION. WITH INITIAL MASS TOTAL THRUST TO WEIGHT CAN BE FOUND.
C

PROGRAM FOCUS

IMPLICIT NONE
REAL ADMSFLW,AVMASS,BPNCH,BOLTZ,CPH2,CPELEC,CPHION,CAP
REAL CONST,CYCREFL,DAYS,DFRACT,DSCHRG,DHE1,DHE2,DHE3,DHE4
REAL DDN1,DDN2,DDN3,DDN4,DDP1,DDP2,DDP3,DDP4
REAL ENERGY,ELECTHR,ELECTEN,F,FRACT,FFBURN,FSNPLW,FPNCH
REAL GRAV,HIONTHR,HEFRACT,IMAXSQ,IMAX,IDOT,ISP,IVOL
REAL ITERS,IMAGNET,IMOPT,KT,KTOPT,LANODE,LPNCH,LINIT,LDOT
REAL MCAP,MPROP,MPROSTR,MMAGNET,MPAYLD,MFUEL,MFUELSY
REAL MSHIELD,MSFLW,MTOT,MUNOT,MH2,NFTHRST,PNCHRAD,PVOL
REAL PNCHTIM,PABSW,PI2R,PIN,PI,PMAGNET,PROPTH, QDOTREM
REAL QLEFT,RHOI,RA,RC,RHOCU,REPRATE
REAL SIGVDHE,SIGVDDN,SIGVDDP,SPECEN,TOTHRST,TFP,TPLOSS
REAL TDELTA,TPFDHE,TPFDN,TPFDDP,TAVG,TPBREM,TPCYC
REAL THICK,TDISION,TSTAG,TTHROAT,VOLT,VRUN,VHIONEX
REAL VHIONTH,VELECTH,VELECEX,WCAP,WDHE,WDDN,WDDP,WASTE
REAL X,XSECTAR

C DECLARE ARRAYS FOR ITERATIONS

REAL DELTAP(10000),DNP(10001),HENP(10001),NPNCH(10000)
REAL PFDHE(10000),PFDDN(10000),PFDDP(10000),PFTOT(10000)
REAL PBREM(10000),PCYC(10000),PLOSS(10000),RRDHE(10000)
REAL RRDDN(10000),RRDDP(10000)

INTEGER I,J,N

C CLEAR ALL ARRAYS

DO 100 I = 1,10000

DNP(I) = 0
NPNCH(I) = 0
HENP(I) = 0
RRDHE(I) = 0
RRDDN(I) = 0
RRDDP(I) = 0
PFDHE(I) = 0
PFDDN(I) = 0
PFDDP(I) = 0
PFTOT(I) = 0
PBREM(I) = 0
PCYC(I) = 0
PLOSS(I) = 0
DELTAP(I) = 0

100 CONTINUE

C
C
C IMAXSQ = MAXIMUM CURRENT SQUARED (AMPS)
C IMOPT = ASSUMED VALUE OF MAXIMUM ATTAINABLE CURRENT (AMPS)
C KTOPT = CORRESPONDING PLASMA TEMPERATURE ASSUMING T GOES AS I**2 (KEV)
C CONST = CONSTANT OF PROPORTIONALITY BETWEEN TEMP AND CURRENT (KEV/A**2)
C BOLTZ = BOLTZMANN'S CONSTANT (J/K)
C RHOI = INITIAL FILL GAS DENSITY (KG/M**3)
C VRUN = PLASMA SHEATH RUNDOWN VELOCITY AT THE END OF THE ANODE (M/S)
C RA = ANODE RADIUS (M)
C RC = CATHODE RADIUS (M)
C LANODE = ANODE LENGTH (M)
C PNCHRAD = RADIUS OF PINCH (M)
C LPNCH = PINCH LENGTH (M)
C FSNPLW = SNOWPLOW EFFICIENCY FACTOR, FRACTION OF INITIAL FILL GAS
C WHICH IS ENTRAINED IN THE RUNDOWN.
C FPNCH = PINCH EFFICIENCY FACTOR, FRACTION OF GAS IN RUNDOWN WHICH
C IS TRAPPED INSIDE THE PINCH.
C F = TOTAL EFFICIENCY = FSNPLW*FPNCH
C DFRACT = PERCENTAGE OF DEUTERIUM IN FILL GAS
C HEFRACT = PERCENTAGE OF HELIUM IN FILL GAS
C AVMASS = AVERAGE MASS OF PARTICLES TRAPPED IN PINCH (KG)
C ITERS = NUMBER OF ITERATIONS PERFORMED DURING EACH PINCH
C NPINCH(I) = PINCH NUMBER DENSITY FOR Ith ITERATION (M**3)
C REPRATE = NUMBER OF FIRINGS PER UNIT TIME (S**-1)
C KT = ENERGY OF PARTICLES IN PINCH (KEV)
C IVOL = INITIAL VOLUME BETWEEN ANODE AND CATHODE (M**3)
C PNCHTIM = DURATION OF STABLE PINCH PHASE (S)
C PVOL = FINAL VOLUME OF PINCH (M**3)
C PFDHE(I) = FUSION POWER FROM D-HE3 REACTION FOR Ith ITERATION (W)
C PFDDN(I) = FUSION POWER FROM DDN REACTION FOR Ith ITERATION (W)
C PFDDP(I) = FUSION POWER FROM DDP REACTION FOR Ith ITERATION (W)
C PFTOT(I) = TOTAL FUSION POWER FOR Ith ITERATION [PFDHE+PFDDN+PFDDP (W)]
C TPFDHE = TOTAL FUSION POWER FROM DHe3 REACTION (W)
C TPFDDN = TOTAL FUSION POWER FOR DDn REACTION (W)
C TPFDDP = TOTAL FUSION POWER FOR DDp REACTION (W)
C TFP = TOTAL FUSION POWER (W)

C PBREM(I) = RADIATIVE LOSSES DUE TO BREMSSTRAHLUNG RADIATION (W)
C PCYC(I) = RADIATIVE LOSSES DUE TO CYCLOTRON RADIATION (W)
C CYCREFL = FRACTION OF CYCLOTRON RADIATION RETAINED BY PLASMA
C PIN = POWER NECESSARY FOR THE OPERATION OF THE FOCUS (W)
C BPNCH = MAGNETIC FIELD IN PINCH (DETERMINES PCYC) (T)
C PLOSS(I) = TOTAL POWER LOST OR REQUIRED TO OPERATE DEVICE (W)
C DELTAP(I) = NET POWER INCREASE OR DECEREASE (W)
C TPBREM = TOTAL BREMSSTRAHLUNG RADIATION (W)
C TPCYC = TOTAL CYCLOTRON RADIATION GENERATED (W)
C TPLOSS = TOTAL RADIATIVE POWER LOSSES (W)
C TDELTAP = TOTAL NET CHANGE IN POWER (W)
C WCAP = INITIAL ENERGY STORED IN CAPACITOR BANKS (J)
C VOLT = CHARGING POTENTIAL OF CAPACITOR BANKS (V)
C CAP = INITIAL EXTERNAL CAPACITANCE (CAPACITOR BANK) (F)
C LINIT = INITIAL INDUCTANCE OF EXTERNAL CIRCUIT (H)
C LDOT = TIME RATE OF CHANGE OF COAXIAL INDUCTANCE (H/S)
C IDOT = RATE OF CHANGE OF CURRENT (A/S)
C A1-A4 = CURVE FIT VALUES TO FIND REACTION RATE PARAMETERS
C SIGVDHE = REACTION RATE PARAMETER FOR D-HE3 (M**3/S)
C SIGVDDN = REACTION RATE PARAMETER FOR DDN (M**3/S)
C SIGVDDP = REACTION RATE PARAMETER FOR DDP (M**3/S)
C WDHE = ENERGY RELEASED PER D-HE3 REACTION (J)
C WDDN = ENERGY RELEASED PER DDN REACTION (J)
C WDDP = ENERGY RELEASED PER DDP REACTION (J)
C DNP(I) = NUMBER DENSITY OF DEUTERIUM IN PINCH (M**-3)
C HENP(I) = NUMBER DENSITY OF HELIUM IN PINCH (M**-3)
C RRDHE(I) = RECTION RATE FOR D-HE3 REACTION (M**-3S**-1)
C RRDDN(I) = REACTION RATE FOR DDN REACTION (M**-3S**-1)
C RRDDP(I) = REACTION RATE FOR DDP REACTION (M**-3S**-1)
C DSCHRG = TIME FOR FILL GAS TO BE DISCHARGED (S)
C XSECTAR = CROSS SECTIONAL AREA OF FOCUS DEVICE (M**2)
C NFTHRST = THRUST DUE TO EXPELLED (NON-PINCH) GASES (N)
C FFBURN = FRACTION OF FUEL BURNT DURING STABLE PINCH PHASE
C FRACT = FRACTION OF ESCAPING CYCLOTRON RADIATION ABSORBED
C IN THE WALLS OF THE MIXING CHAMBER AND ELECTRODES
C PABSW = CYCLOTRON POWER ABSORBED IN THE WALLS & ELECTRODES (MW)
C RHOCU = ELECTRICAL RESISTIVITY OF COPPER (OHM M)
C PI2R = POWER GENERATED DUE TO OHMIC HEATING IN THE ELECTRODES (MW)
C MH2 = MASS OF DIATOMIC HYDROGEN MOLECULE (KG)
C WASTE = WASTE HEAT DUE TO OHMIC HEATING AND RADIATION ABSORBED (MW)
C MSFLW = COOLANT MASS FLOW RATE REQUIRED TO COOL WASTE HEAT AND
C KEEP TURBINE INLET TEMPERATURE LESS THAN 2000 K (KG/S)
C ADMSFLW = ANY ADDITIONAL HYDROGEN USED FOR PROPELLANT (KG/S)
C ENERGY = ELECTRICAL ENERGY PRODUCED BY TURBINE AT 20% EFFICIENCY (MW)
C TAVG = MASS AVERAGED TEMPERATURE OF COOLANT FROM TURBINE AND ANY
C ADDITIONAL PROPELLANT FLOW (K)
C THICK = CALCULATED SHIELD THICKNESS BASED ON A MISSION 'DAYS' LONG
C WHERE NEUTRON FLUENCE IS TO BE LESS THAN 10**17 PER M**2 (M)
C TDISION = TEMPERATURE AT WHICH PROPELLANT IS ASSUMED TO BECOME COMPLETELY
C DISSOCIATED AND IONIZED (K)
C TSTAG = PROPELLANT STAGNATION TEMPERATURE AT NOZZLE ENTRANCE (K)
C TTHROAT = PROPELLANT TEMPERATURE AT MAGNETIC NOZZLE THROAT (K)
C CPH2 = CONSTANT PRESSURE SPECIFIC HEAT OF DIATOMIC HYDROGEN (J/KG*K)
C CPELEC = CONSTANT PRESSURE SPECIFIC HEAT OF FREE ELECTRON GAS (J/KG*K)
C CPHION = CONSTANT PRESSURE SPECIFIC HEAT OF FREE HYDROGEN ION GAS (J/KG*K)
C VHIONTH = HELIUM ION GAS VELOCITY AT MAGNETIC NOZZLE THROAT (M/S)
C VELECTH = ELECTRON GAS VELOCITY AT MAGNETIC NOZZLE THROAT (M/S)
C VHIONEX = HELIUM ION GAS VELOCITY AT MAGNETIC NOZZLE EXIT (M/S)
C VECEX = ELECTRON GAS VELOCITY AT MAGNETIC NOZZLE EXIT (M/S)
C HIONTHR = THRUST DUE TO EXPELLED HYDROGEN IONS (N), (LBF)

```

C ELECTHR = THRUST DUE TO EXPELLED ELECTRONS (N), (LBF)
C PROPTHR = TOTAL PROPELLANT THRUST (N), (LBF)
C IMAGNET = CURRENT NECESSARY TO PRODUCE 2 TESLA MAGNETIC FIELD (A)
C DAYS = NUMBER OF DAYS THRUSTER WILL BE FIRED (DAYS)
C ELECTEN = TOTAL ELECTRICAL ENERGY TO BE SUPPLIED BY CAPACITORS (W)
C SPECEN = SPECIFIC ENERGY OF CAPACITOR BANKS (KJ/KG)
C PMAGNET = POWER NECESSARY TO RUN MAGNET (MW)
C QDOTREM = POWER NECESSARY TO BRING PROPELLANT TO TDISION (W)
C QLEFT = CHARGED PARTICLE POWER REMAINING AFTER PROPELLANT IS
C COMPLETELY IONIZED AND DISSOCIATED (W)
C MCAP = TOTAL CAPACITOR BANK MASS (KG)
C MPROP = TOTAL HYDROGEN PROPELLANT MASS (KG)
C MPROSTR = MASS OF PROPELLANT SYSTEM (TANKS) AND SHIP STRUCTURE (KG)
C MMAGNET = MASS OF MERIDIONAL MAGNETIC NOZZLE (KG)
C MPAYLD = PAYLOAD MASS FOR A MANNED MARS MISSION (KG)
C MFUEL = MASS OF FUSION FUELS (DEUTERIUM AND HELIUM-3) USED (KG)
C MFUELSY = MASS OF FUEL SYSTEM WHICH CARRIES AND INJECTS FUELS (KG)
C MSHIELD = TOTAL SHIELD MASS NECESSARY TO ATTENUATE DD NEUTRONS (KG)
C MTOT = SUMM OF ALL SYSTEM MASSES (KG)
C ISP = SPECIFIC IMPULSE (S)
C MUNOT = PERMITTIVITY OF FREE SPACE (H/M)
C GRAV = ACCELERATION OF GRAVITY AT EARTH'S SURFACE (M/S**2)
C TOTHRST = TOTAL OF ALL THRUSTS (N), (LBF)

```

```

C *****
C ***** DEFINE VALUES OF ALL CONSTANTS *****
C *****

```

```

DATA MUNOT,PI, GRAV/1.257E-6, 3.1415, 9.8/
DATA CYCREFL, DSCHRG/0.6, 1.0E-7/
DATA DHE1, DHE2, DHE3, DHE4/0.35715, -3.32451, 10.11363, -25.66533/
DATA DDN1, DDN2, DDN3, DDN4/0.29811, -2.08296, 5.70135, -22.0878/
DATA DDP1, DDP2, DDP3, DDP4/0.30795, -2.12009, 5.68718, -22.03746/
DATA WDHE, WDDN, WDDP, IMAGNET/2.93E-12, 5.24E-13, 6.46E-13, 3.18E5/
DATA MH2, BOLTZ, RHOCU, FRACT/3.34E-27, 1.38E-23, 1.673E-8, 0.2/
DATA CPH2, CPELEC, CPHION, TDISION/4157, 1.517E7, 8267, 5000/

```

```

C *****
C ***** OPEN AND READ FROM DATA INPUT FILE *****
C *****

```

```

OPEN (UNIT=1, FILE='NOZ.DAT', STATUS='OLD')

READ(1, *)
READ(1, *) RA
READ(1, *)
READ(1, *) RC
READ(1, *)

```

```

READ (1,*) LANODE
READ (1,*)
READ (1,*) RHOI
READ (1,*)
READ (1,*) VOLT
READ (1,*)
READ (1,*) CAP
READ (1,*)
READ (1,*) LINIT
READ (1,*)
READ (1,*) SPECEN
READ (1,*)
READ (1,*) FSNPLW
READ (1,*)
READ (1,*) FPNCH
READ (1,*)
READ (1,*) LPNCH
READ (1,*)
READ (1,*) PNCHRAD
READ (1,*)
READ (1,*) DFRACT
READ (1,*)
READ (1,*) HEFRACT
READ (1,*)
READ (1,*) IMOPT
READ (1,*)
READ (1,*) REPRATE
READ (1,*)
READ (1,*) PNCHTIM
READ (1,*)
READ (1,*) ITERS
READ (1,*)
READ (1,*) ADMSFLW
READ (1,*)
READ (1,*) DAYS

```

```
CLOSE (UNIT=1)
```

```

C *****
C ***** CALCULATE FOCUS PARAMETERS *****
C *****
C

```

```
XSECTAR = PI*(RC**2 - RA**2)
```

```
IVOL = XSECTAR*LANODE
```

```
PVOL = PI*PNCHRAD**2*LPNCH
```

```
F = FSNPLW * FPNCH
```

```
AVMASS = HEFRACT*5.0E-27 + DFRACT*3.34E-27
```

```
C ***** MAXIMUM CURRENT *****
```

```
C GIVEN BY DOLAN, VOL 2
```

```
IMAXSQ = 2.704*SQRT((CAP*VOLT**3)/(MUNOT*LINIT*LOG(RC/RA)))*
```

```

&          ((RA**2*RHOI/ MUNOT)**0.25)
IMAX = SQRT(IMAXSQ)
C ***** PLASMA TEMPERATURE *****
C ASSUME THAT PLASMA TEMPERATURE SCALES AS I SQUARED
C ASSUME MAXIMUM ATTAINABLE CURRENT IS IMOPT
KT = MUNOT*IMAXSQ*AVMASS*LPNCH/(78.96*F*RHOI*LANODE*
&      (RC**2 - RA**2)*1.6E-16)
CONST = KT/IMAXSQ
KTOPT = CONST*IMOPT**2
C ***** RUNDOWN VELOCITY *****
C THE RUNDOWN VELOCITY IS CALCULATED USING THE MOMENTUM EQUATION
C VRUN = SQRT(MUNOT*IMOPT**2/(78.96*RA**2*RHOI))
C ***** PINCH NUMBER DENSITY *****
C NPNCH(1) = F*RHOI*LANODE*(RC**2 - RA**2)/(AVMASS*PNCHRAD**2
&      *LPNCH)
DNP(1) = DFRACT * NPNCH(1)
HENP(1) = HEFRACT * NPNCH(1)
I = 1
C ***** CALCULATE REACTION RATES *****
C *****
X = LOG10(KTOPT)
SIGVDHE = 1.0E-6*(10**(DHE1*(X**3)+DHE2*(X**2)
&      +DHE3*X+DHE4))
SIGVDDN = 1.0E-6*(10**(DDN1*(X**3)+DDN2*(X**2)
&      +DDN3*X+DDN4))
SIGVDDP = 1.0E-6*(10**(DDP1*(X**3)+DDP2*(X**2)
&      +DDP3*X+DDP4))
DOWHILE (I .LE. ITERS)
RRDHE(I) = DNP(I) * (HENP(I) *SIGVDHE)
RRDDN(I) = DNP(I) * (DNP(I) *SIGVDDN)
RRDDP(I) = DNP(I) * (DNP(I) *SIGVDDP)

```

C ***** DETERMINE CHARGED FUSION POWER FROM PINCH *****
C
C

PFDE (I) = RRDHE (I) * WDHE * PVOL * REPRATE * PNCHTIM * (1/ITERS) * 1.0E-6
PFDDP (I) = RRDDP (I) * WDDP * PVOL * REPRATE * PNCHTIM * (1/ITERS) * 1.0E-6
PFDDN (I) = 0.25 * RRDDN (I) * WDDN * PVOL * REPRATE * PNCHTIM * 1.0E-6
& * (1/ITERS)

PFTOT (I) = PFDE (I) + PFDDN (I) + PFDDP (I)

C ***** DETERMINE NET POWER CHANGE *****
C
C

PIN = VOLT * IMOPT * REPRATE * DSCHRG * 1.0E-6

C BPNCH IS THE MAGNETIC FIELD AT THE SURFACE OF THE PINCH
C WHICH IS RESPONSIBLE FOR THE CYCLOTRON RADIATION EMITTED

BPNCH = MUNOT * F * IMOPT / (2 * PI * PNCHRAD)

C POWER LOST IS THE STEADY STATE LOSS (PER UNIT VOLUME) TIMES THE
C PLASMA VOLUME TIMES THE TIME PER PINCH TIMES THE NUMBER OF PINCHES
C PER SECOND.

PCYC (I) = 6.21E-17 / (8 * PI) * MUNOT ** 2 * (F * IMOPT) ** 2 * LPNCH * NPNCH (I) *
& KTOPT * (1 + KTOPT / 146) * REPRATE * PNCHTIM * (1/ITERS) * 1.0E-6

PBREM (I) = 5.35E-37 * (F ** 2) * NPNCH (I) * (DNP (I) + (4 * HENP (I)))
& * (SQRT (KTOPT)) * PVOL * REPRATE * PNCHTIM * (1/ITERS)
& * 1.0E-06

C ASSUME THAT CYCREFL % OF CYCLOTRON RADIATION IS RETAINED IN PLASMA

PLOSS (I) = PBREM (I) + (1 - CYCREFL) * PCYC (I)

DELTAP (I) = PFTOT (I) - PLOSS (I)

C ***** DETERMINE THE THRUST FROM EXPELLED FILL GASES *****
C ***** ASSUMING GASES ARE EXPELLED FROM THE DEVICE IN 1E-7 S *****

NFTHRST = RHOI * VRUN ** 2 * XSECTAR * REPRATE * DSCHRG

DNP (I+1) = DNP (I) - (RRDHE (I) + 2 * RRDDN (I) + 2 * RRDDP (I)) * PNCHTIM
& * (1/ITERS)

HENP (I+1) = HENP (I) - RRDHE (I) * PNCHTIM * (1/ITERS)

NPNCH (I+1) = DNP (I+1) + HENP (I+1)
I = I + 1

ENDDO

TFP = 0

TPLOSS = 0
TDELTA P = 0
TPFDHE = 0
TPFDN = 0
TPFDDP = 0
TPBREM = 0
TPCYC = 0

C
C
C

TOTAL ELEMENTS IN ALL ARRAYS

DO 200 J = 1,ITERS

TFP = TFP + PFTOT(J)
TPLOSS = TPLOSS + PLOSS(J)
TDELTA P = TDELTA P + DELTA P(J)
TPFDHE = TPFDHE + PFDHE(J)
TPFDN = TPFDN + PFDN(J)
TPFDDP = TPFDDP + PFDDP(J)
TPBREM = TPBREM + PBREM(J)
TPCYC = TPCYC + PCYC(J)

200 CONTINUE

C ***** CYCLOTRON RADIATION ABSORBED IN WALL AND ELECTRODES *****

PABSW = FRACT * (1-CYCREFL)*TPCYC

C ***** TOTAL POWER DISSIPATED IN ELECTRODES BY OHMIC HEATING *****

PI2R = IMOPT**2*RHOCU*LANODE*(1/(PI*RA**2)+1/(PI*(RC**2
& -RA**2)))*1.0E-6*DSCHRG*REPRATE

C ***** POWER TO BE REMOVED FROM MAGNET (MW) *****

PMAGNET = 0.01

C ***** TOTAL POWER TO BE REMOVED FROM THE WALLS AND ELECTRODES *****

C ***** AND MAGNET *****

WASTE = PI2R + PABSW + PMAGNET

C ** NEED TO KEEP INLET TEMPERATURE TO TURBINE BELOW ABOUT 2000K *****

C *****MASS FLOW REQUIRED TO DO SO IS GIVEN BY *****

MSFLW = WASTE*61.14/(2000 - 20)

C ***** ASSUME TURBINE TO BE 20% EFFICIENT *****

C ELECTRICAL POWER GENERATED IS 20% OF WASTE HEAT

ENERGY = 0.2*WASTE

C *** ASSUME TURBINE EXIT TEMPERATURE IS ABOUT 700K, WHERE IT CAN

C BE MIXED WITH ADDITIONAL MASS FLOW AT 20K *****

TAVG = (MSFLW*700 + ADMSFLW*20)/(MSFLW+ADMSFLW)

C **** ASSUME GAS ABSORBS ALL FUSION POWER PRODUCED, MIXES UNIFORMLY
C AND EXITS AT A UNIFORM TEMPERATURE OF TOUT *****

C ASSUME GAS ABSORBS HEAT UP TO 5000K AS H2 WITH GAMMA=1.40
C THE HEAT REMOVED FROM THE SYSTEM IN DOING SO IS:

C *****
C QDOTREM=(MSFLW+ADMSFLW)*CPH2*(TDISION-TAVG)

C THIS LEAVES A TOTAL OF QLEFT TO BE ABSORBED BY A COMPLETELY
C DISSOCIATED AND IONIZED COMBINATION OF AN ELECTRON GAS
C AND A GAS OF HYDROGEN IONS.

C *****
C QLEFT=1.0E6*(TDELTA-PIN)-QDOTREM

C NOW THE POWER IS ABSORBED BY AN ELECTRON GAS AND A HYDROGEN
C ION GAS. THE CONSTANT VOLUME HEAT CAPACITY OF A FREE
C MONATOMIC GAS CAN BE FOUND USING FERMI-DIRAC STATISTICS TO BE
C $CV=(N/2)*R$, WHERE R IS THE UNIVERSAL GAS CONSTANT AND N IS THE
C NUMBER OF DEGREES OF FREEDOM OF EACH PARTICLE, IN OUR CASE, 3.

C ***** R = 8.3143 J/mol K *****

C ASSUMING AN IDEAL GAS, $CP = CV + R$
C ie. $CP = (5/2)*R = 20.786$ J/mol K
C 1 MOLE OF ELECTRONS IS $5.48E-7$ KG
C 1 MOLE OF H+ IONS IS $1.006E-3$ KG
C CPELEC = $1.517E7$ J/KG K
C CPHION = 8267 J/KG K

C QLEFT = MDOT*(CPELEC+CPHION)*DELTAT
C AFTER ABSORPTION OF THIS ENERGY, THE PLASMA IS ASSUMED TO
C COME TO THERMAL EQUILIBRIUM AT STAGNATION CONDITIONS, ie. $v=0$.

C *****
C TSTAG = TDISION + QLEFT/((MSFLW+ADMSFLW)*((CPHION*0.999455)
C & +(0.000545*CPELEC)))

C ASSUME THAT THE FLOW NOW ENTERS A MERIDIONAL MAGNETIC NOZZLE
C WITH ONE COIL AT THE THROAT OF THE NOZZLE.
C THE SPECS FOR SUCH A NOZZLE ARE GIVEN IN THE AL REPORT
C "CHARACTERIZATION OF PLASMA FLOW THROUGH MAGNETIC NOZZLES".

C ACCORDING TO THE SPECS, TSTAG/TTHR = 1.35
C AND VEXIT/VTHROAT = 2.0

C *****
C TTHROAT = TSTAG/1.35

C FROM CONSERVATION OF ENERGY: $CP*DELTAT=(1/2)*VTHROAT**2$
C THERMAL ENERGY IS CONVERTED TO ENTHALPY OF THE PLASMA

C *****

```

VHIONTH=SQRT(2*CPHION*(TSTAG-TTHROAT))
VELECTH=SQRT(2*CPELEC*(TSTAG-TTHROAT))
C *****

C
C FLOW EXITS TWICE AS FAST BECAUSE OF EXPANSION
C THROUGH THE NOZZLE.
C
VHIONEX = 2.0*VHIONTH
VELECEX = 2.0*VELECTH

C RESULTING THRUST FROM PLASMA

C *****
ELECTHR = 5.45E-4*(MSFLW+ADMSFLW)*VELECEX
HIONTHR = 0.999455*(MSFLW+ADMSFLW)*VHIONEX

PROPTHR = ELECTHR + HIONTHR

TOTHRST = NFTHRST + PROPTHR

FFBURN = 1-(NPNCH(ITER+1)/NPNCH(1))
C *****

C ***** ESTIMATE MASSES FOR MARS MISSION *****
C
C ASSUME FIXED PAYLOAD MASS OF ABOUT 100 METRIC TONS

C *****
MPAYLD = 1.0E5
C *****

C MASS OF NECESSARY PROPELLANT, PROPELLANT SYSTEM AND STRUCTURE
C (TANK,PUMPS,CREW CABIN...ETC.)

C *****
MPROP = (MSFLW+ADMSFLW)*DAYS*86400

MPROSTR = 0.15*MPROP
C *****

C MASS OF DEUTERIUM AND HELIUM 3 FUEL

C *****
MFUEL = RHOI*IVOL*REPRATE*DAYS*86400

MFUELSY = 0.1*MFUEL
C *****

C DETERMINE THE NECESSARY CAPACITOR MASS USING INPUTTED
C SPECIFIC ENERGY
C
C ASSUME EFFICIENCY OF CONVERSION FROM ELECTRICAL TO
C MAGNETIC ENERGY IS CONSTANT.
C
WNOT = 0.5*CNOT*VNOT**2 = B**2/(2*MUNOT)

```

```

C SINCE B IS PROPORTIONAL TO I, ASSUME NECESSARY STORED
C ELECTRICAL ENERGY IS PROPORTIONAL TO I**2.
C
C W = WNOT*(IOPT/INOT)**2

C *****
C ELECTEN = 0.5*CAP*VOLT**2*((IMOPT+IMAGNET)/IMAX)**2
C *****

C NEED ELECTEN IN kJ AND SPECEN IN kJ/kg

C *****
C MCAP = ELECTEN/1000/SPECEN
C *****

C
C CALCULATE MASS OF SHIELD NECESSARY TO KEEP NEUTRON FLUENCE
C BELOW 10**13 FOR A MISSION THAT IS DAYS LONG
C
C LITHIUM HYDRIDE SHIELD THICKNESS IS IN METERS

C ASSUME SHIELD IS 1 METER FROM NEUTRON SOURCE AND SUBTENDS
C AN ANGLE SUCH THAT ABOUT 12.5% OF ALL NEUTRONS RELEASED
C IN THE DDn REACTION HIT THE SHIELD

C *****
C THICK = 0.1*LOG(0.125*RRDDN(ITERS+1)*PNCHTIM*REPRATE*PVOL
C & *DAYS/(4*PI*1.157E12))
C *****

C ASSUME SHIELD HAS A CROSS SECTIONAL AREA OF ONE METER
C MASS = DENSITY*AREA*THICKNESS (DENSITY OF LiH IS
C APPROXIMATELY 725 KG/M**3)

C *****
C MSHIELD = 725*PI*THICK
C *****

C MASS OF MAGNET TO BE USED AT THE CENTER OF THE MAGNETIC NOZZLE
C ASSUME A FIELD OF 2 TESLA IS NEEDED AT THE THROAT WHICH HAS
C A RADIUS OF 10 CM. THE COPPER MAGNET WILL THUS HAVE AN INNER RADIUS
C OF 10 CM AND AN OUTER RADIUS CHOSEN AS 50 CM IN ORDER TO
C MINIMIZE RESISTANCE. THE MAGNET WILL BE PULSED 100 TIMES PER
C SECOND AND EACH PULSE WILL LAST ABOUT 10**-4 SECONDS. THE LENGTH
C OF THE MAGNET WAS CHOSEN TO BE 1 CM.

C *****
C MMAGNET = 67.55
C *****

C POWER DISSIPATED IN THE MAGNET IS I**2*R*PNCHTIM*REPRATE
C OR ABOUT 10 KW. NOTE THAT THESE NUMBERS GIVE ENERGY DENSITIES
C IN THE MAGNET WHICH ARE MUCH LESS THAN THE MAXIMUM TOLERABLE
C ENERGY DENSITY AT WHICH COPPER BEGINS TO MELT.

```

```

C ***** TOTAL MASS CALCULATION (IN KG) *****
C
      MTOT = MPAYLD+MCAP+MPROP+MPROSTR+MFUEL+MSHIELD
&          +MFUELSY+MMAGNET

C
C ***** CALCULATION OF SPECIFIC IMPULSE *****
C
      ISP = TOTHRST / (GRAV * (RHOI * IVOL * REPRATE + MSFLW + ADMSFLW))

C ***** WRITE RESULTS TO OUTPUT FILE FIN.OUT *****

      OPEN (UNIT=2, FILE='NOZ.OUT', STATUS='NEW')

      WRITE(2,*) 'INITIAL FILL GAS DENSITY'
      WRITE(2,*) RHOI
      WRITE(2,*) 'MAXIMUM CURRENT IN AMPS'
      WRITE(2,*) IMAX
      WRITE(2,*) 'PLASMA PINCH TEMPERATURE IN KEV'
      WRITE(2,*) KT
      WRITE(2,*) 'AT A CURRENT OF (AMPS)'
      WRITE(2,*) IMOPT
      WRITE(2,*) 'PLASMA PINCH TEMPERATURE IN KEV'
      WRITE(2,*) KTOPT
      WRITE(2,*) 'RUNDOWN VELOCITY AT THE END OF THE ANODE IN M/S'
      WRITE(2,*) VRUN
      WRITE(2,*)
      WRITE(2,*) 'INITIAL AND FINAL D NUMBER DENSITY IN M**-3'
      WRITE(2,*) DNP(1), DNP(ITERS+1)
      WRITE(2,*) 'INITIAL AND FINAL HE NUMBER DENSITY IN M**-3'
      WRITE(2,*) HENP(1), HENP(ITERS+1)
      WRITE(2,*) 'FRACTIONAL FUEL BURN'
      WRITE(2,*) FFBURN
      WRITE(2,*)
      WRITE(2,*) 'REACTION RATE PARAMETERS FOR DHe3, DDn, AND DDp '
      WRITE(2,*) 'IN M**3/S'
      WRITE(2,*) SIGVDHE
      WRITE(2,*) SIGVDDN
      WRITE(2,*) SIGVDDP
      WRITE(2,*)

      WRITE(2,*) 'INITIAL AND FINAL REACTION RATES FOR DHe3, DDn,
& AND DDp IN M**-3S**-1'

      WRITE(2,*) RRDHE(1), RRDHE(ITERS)
      WRITE(2,*) RRDDN(1), RRDDN(ITERS)
      WRITE(2,*) RRDDP(1), RRDDP(ITERS)
      WRITE(2,*)
      WRITE(2,*) 'CHARGED PARTICLE FUSION POWER FROM DHe3, DDn, AND
& DDp IN MEGAWATTS'

      WRITE(2,*) TPFDDHE, TPFDDN, TPFDDP
      WRITE(2,*) 'TOTAL FUSION POWER IN MEGAWATTS'
      WRITE(2,*) TFP

```

```

WRITE(2,*) 'POWER NEEDED TO OPERATE FOCUS IN MEGAWATTS'
WRITE(2,*) PIN
WRITE(2,*) 'BREMSSTRAHLUNG AND CYCLOTRON LOSSES IN MEGAWATTS'
WRITE(2,*) TPBREM,(1-CYCREFL)*TPCYC
WRITE(2,*) 'TOTAL POWER LOSSES IN MEGAWATTS'
WRITE(2,*) TPLOSS
WRITE(2,*)

```

```

IF (TDELTAP-PIN .LT. 0) THEN
  WRITE(2,*) 'NET DECREASE IN POWER IN MEGAWATTS'
  WRITE(2,*) TDELTAP-PIN
ELSEIF (TDELTAP-PIN .GT. 0) THEN
  WRITE(2,*) 'NET INCREASE IN POWER IN MEGAWATTS'
  WRITE(2,*) TDELTAP-PIN-PMAGNET
ELSE
  WRITE(2,*) 'THERE IS NO NET CHANCE IN REACTOR POWER'
ENDIF

```

```

WRITE(2,*)
WRITE(2,*) 'TOTAL ELECTRICAL POWER PRODUCED IN MEGAWATTS'
WRITE(2,*) ENERGY
WRITE(2,*) 'TOTAL MASS FLOW RATE IN KG/S'
WRITE(2,*) MSFLW+ADMSFLW
WRITE(2,*) 'PLASMA STAGNATION TEMPERATURE IN K,eV'
WRITE(2,*) TSTAG,TSTAG/12000
WRITE(2,*) 'ION AND ELECTRON EXIT VELOCITIES IN M/S'
WRITE(2,*) VHIONEX,VELECEX
WRITE(2,*) 'FINAL PROPELLANT THRUST IN N'
WRITE(2,*) PROPTH
WRITE(2,*) 'FIRING TIME IN DAYS'
WRITE(2,*) DAYS

```

```

WRITE(2,*)
WRITE(2,*) '***** SYSTEM MASSES IN KG'
WRITE(2,*) 'PAYLOAD MASS:',MPAYLD
WRITE(2,*) 'PROPELLANT MASS:',MPROP
WRITE(2,*) 'PROPELLANT SYSTEM AND STRUCTURE:',MPROSTR
WRITE(2,*) 'FUEL MASS:',MFUEL
WRITE(2,*) 'FUEL SYSTEM MASS:',MFUELSY
WRITE(2,*) 'CAPACITOR MASS:',MCA
WRITE(2,*) 'SHIELD MASS:',MSHIELD
WRITE(2,*) 'MAGNET MASS:',MMAGNET
WRITE(2,*) '***** TOTAL MASS:',MTOT
WRITE(2,*)
WRITE(2,*) 'TOTAL THRUST IN NEWTONS,LBF'
WRITE(2,*) TOTHRST,TOTHRST/4.4482
WRITE(2,*)
WRITE(2,*) 'THRUST TO WEIGHT RATIO'
WRITE(2,*) TOTHRST/(MTOT*GRAV)
WRITE(2,*) 'SPECIFIC IMPULSE IN SECONDS'
WRITE(2,*) ISP
WRITE(2,*) '*****'
WRITE(2,*)

```

```

CLOSE(UNIT=2)

```

```

END

```