

AD-A235 733

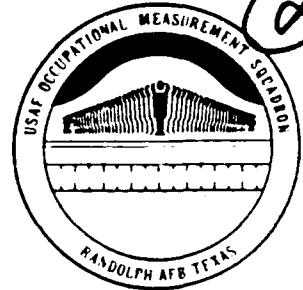

UNITED STATES
AIR FORCE

OCCUPATIONAL SURVEY REPORT

AUTOMATED DATA PROCESSING PREFIXES

ADP PREFIXES - C AND D OFFICERS/D AND W ENLISTED

AFPT 90-CDW-898

APRIL 1991

DTIC
ELECTE
MAY 14 1991
S B D

DTIC FILE COPY

OCCUPATIONAL ANALYSIS PROGRAM
USAF OCCUPATIONAL MEASUREMENT SQUADRON
AIR TRAINING COMMAND
RANDOLPH AFB, TEXAS 78150-5000

APPROVED FOR PUBLIC RELEASE; DISTRIBUTION UNLIMITED

91 5 14 063

DISTRIBUTION FOR
C AND D PREFIX OSR AND SUPPORTING DOCUMENTS

	<u>OSR</u>	<u>ANL</u> <u>EXT</u>	<u>JOB</u> <u>INV</u>
AFMPC/DPMRPQ1	8		
AFMPC/DPMRAD4	1		
AFMPC/DPMYCO	1		
AFMPC/DPMYCP	1		
AL/HRD/MODS	2	1m	1
AL/HRD/ID	1	1m	1
ARMY OCCUPATIONAL SURVEY BRANCH	1		
CCAF/AYX	1		
DEFENSE TECHNICAL INFORMATION CENTER	2		
DET 1, USAFOMS (LACKLAND AFB TX)	1		1
DET 2, USAFOMS (CHANUTE AFB IL)	1		1
DET 3, USAFOMS (KEESLER AFB MS)	1	1	1
DET 4, USAFOMS (SHEPPARD AFB TX)	1		1
DET 5, USAFOMS (LOWRY AFB CO)	1		1
HQ AFCC/DPATO	3		
HQ AFCC/TTA	1		
HQ AFESC/DEHR	1		
HQ AFLC/DPMAE	3		
HQ AFSC/DPAL	3		
HQ AFSC/TTA	1		
HQ AFSPACECOM/MPTT	3		
HQ AFSPACECOM/TTA	1		
HQ ATC/DPAE	3		
HQ ESC/DPTE	3		
HQ ESC/TTA	1		
HQ MAC/DPAT	3		
HQ MAC/TTA	1		
HQ PACAF/DPAT	3		
HQ PACAF/TTA	1		
HQ SAC/DPAT	3		
HQ SAC/TTA	1		
HQ TAC/DPATJ	3		
HQ TAC/TTA	1		
HQ USAF/SCBH	1		
HQ USAF/DPPE	1		
HQ USAFE/DPAT	3		
HQ USAFE/TTA	1		
NCDAC	1		
USAFOMS/OMDQ	1		
USAFOMS/OMYXL	10	2m	10
USMC (CODE TE-310)	1		

m = microfiche only
h = hard copy only

TABLE OF CONTENTS

	<u>PAGE NUMBER</u>
PREFACE	iii
SUMMARY OF RESULTS	iv
INTRODUCTION	1
SURVEY METHODOLOGY	1
Survey Development	1
Survey Administration	1
Survey Population	3
JOB STRUCTURE ANALYSIS	3
Overview	3
Job Structure	3
Group Descriptions	8
DAFSC PREFIX COMPARISONS	21
WRITE-IN COMMENTS	21
JOB SATISFACTION	27
PERSONNEL UTILIZATION	27
IMPLICATIONS	30
APPENDIX A	31

Accession For	
NTIS GRA&I	<input checked="" type="checkbox"/>
DTIC TAB	<input type="checkbox"/>
Unannounced	<input type="checkbox"/>
Justification	
By _____	
Distribution/	
Availability Codes	
Dist	Avail and/or Special
A-1	

PREFACE

This occupational survey report (OSR) presents the results of a detailed Air Force Occupational Survey of the C and D Prefix officers and the W and D Prefix enlisted personnel. Authority for conducting occupational surveys is contained in AFR 35-2. Computer products used in this report are available for use by operations and training officials.

The original survey instrument for this project was developed by Captain William P. Knoll, Occupational Analyst. MSgt Cornelia Wharton provided computer support. Mrs Lauri Odness analyzed the data and wrote the final report. Administrative support was provided by Ms Raquel A. Soliz. This report has been reviewed by Mr Gerald R. Clow, Chief, Management Applications Section, USAF Occupational Measurement Squadron.

Copies of this report are distributed to Air Staff sections or other interested training and management personnel. Additional copies are available upon request to the USAF Occupational Measurement Squadron, Attention: Chief Occupational Analysis Branch (OMY) Randolph Air Force Base, Texas 78150-5000.

BOBBY P. TINDELL, Colonel, USAF
Commander
USAF Occupational Measurement
Squadron

JOSEPH S. TARTELL
Chief, Occupational Analysis Branch
USAF Occupational Measurement
Squadron

SUMMARY OF RESULTS

1. Survey Coverage: Survey results were based on the responses from 19 D Prefix officers, 462 C Prefix officers, 29 D Prefix enlisted personnel, and 243 W Prefix enlisted personnel. The sample accounts for 60 percent of those receiving inventory booklets.
2. Job Structure: Job structure analysis revealed 5 clusters, with 25 jobs within the clusters, and 3 independent jobs in the sample. Seventy-nine percent of the sample were accounted for in the job structure. The remaining 21 percent performed tasks not related to the other personnel.
3. DAFSC Prefix Comparisons: The C Prefix officers are spending most of their time in program and project planning, while the D Prefix officer and D and W Prefix enlisted personnel spend most of their time in operational functions. Very few tasks are performed by half of the respondents for the four prefixes.
4. Job Satisfaction: All groups in the job structure had high job satisfaction indicators for job interest and sense of accomplishment, however; they feel their training and talents are not being utilized to the utmost. Forty percent of the respondents within the prefix groups related their training was not being utilized.
5. Personnel Utilization: Comparing 36-1 and 39-1 job descriptions to tasks performed appears to satisfactorily describe the work performed by prefix holders in prefix-related jobs. Several factors indicate numerous individuals may have been inappropriately awarded a prefix.
6. Implications: The analysis revealed that some personnel who hold a prefix are being utilized in prefix positions, while some personnel might be underutilized or even misutilized. A position by position audit would be beneficial in determining prefix-related jobs and which personnel should hold them.

OCCUPATIONAL SURVEY REPORT
OFFICER C PREFIX - AUTOMATED FUNCTIONAL APPLICATIONS ANALYST
OFFICER D PREFIX - AUTOMATED SYSTEMS PROGRAMS DESIGNER
ENLISTED D PREFIX - AUTOMATED SYSTEMS PROGRAMMING TECHNICIAN
ENLISTED W PREFIX - AUTOMATED FUNCTIONAL APPLICATIONS ANALYST/MONITOR

INTRODUCTION

This report summarizes the results of the occupational survey of the C and D Prefix officers and the D and W Prefix enlisted personnel. The survey was requested by HQ AFMPC/DPMRPQ1. The intent of the survey is to: 1) perform a review of tasks performed compared to AFR 39-1 and AFR 36-1 to ensure utilization of the prefixes and 2) review duties being performed, as well as those that are not and possibly need to be. Table 1 shows the total survey sample distribution by prefix as of February 1990.

SURVEY METHODOLOGY

Survey Development

The survey instrument used to collect data for the C and D Prefix officer and D and W Prefix enlisted personnel was USAF Job Inventory AFPT 90-CDW-898 dated February 1990. The job inventory was developed based on interviews at 8 different locations with approximately 100 subject-matter experts.

The job inventory was composed of two sections; the first section was a background section used to gather personal information, such as name, rank, grade, job interest, time in present job, and organizational level. The second section was a task list, a collection of 692 task statements related to all aspects of the jobs performed by C and D Prefix officers and C and W Prefix enlisted personnel.

Survey Administration

From May 1990 to August 1990, Survey Control Officers at Consolidated Base Personnel offices distributed the Prefix job inventories to the required personnel. Personnel participants were selected from a computer-generated mailing list provided by Armstrong Laboratory, Human Resources Directorate (AL/HRD).

To complete the survey, the incumbents first answered the background questions, then checked each task performed in their present job that was prefix related. After selecting all tasks performed, each participant then rated each of these tasks on a 9-point scale showing relative time spent on that task as compared to all other tasks checked. The ratings ranged from 1

APPROVED FOR PUBLIC RELEASE; DISTRIBUTION UNLIMITED

TABLE 1
PREFIX DISTRIBUTION OF SURVEY SAMPLE

	PERCENT OF ASSIGNED <u>(N=1,251)</u>	PERCENT OF SAMPLE <u>(N=753)</u>
ENLISTED D PREFIX	6	4
ENLISTED W PREFIX	31	32
OFFICERS C PREFIX	60	61
OFFICERS D PREFIX	3	3

(very small amount of time spent) through 5 (about average time spent) to 9 (very large amount of time spent). The participants' ratings were combined and the total assumed to represent 100 percent of the time spent on the job related to their prefix. Each task rating was then divided by the total tasks rated and multiplied by 100 to provide a relative percentage of time spent on each task. This procedure provides a basis for comparing tasks in terms of both percent members performing and average percent time spent.

Survey Population

A total of 468 D and W Prefix enlisted personnel and 783 C and D officers received job inventory booklets. Table 2 shows AFSC distribution, while Table 3 shows MAJCOM distribution for the total survey sample. Fifty-five respondents were eliminated by automated quality control checks, because they perform less than 5 tasks of the 682 in the inventory. The 753 respondents in the final survey sample represent 60 percent of those receiving inventory booklets. The final survey sample consisted of 462 C Prefix officers, 19 D Prefix officers, 243 W Prefix enlisted personnel, and 29 D Prefix enlisted personnel.

JOB STRUCTURE ANALYSIS

Overview

An important function of the USAF Occupational Analysis Program is examining the job structure of a career area or utilization field. Based on incumbent responses to the survey, groups of incumbents spending similar amounts of time performing similar tasks are identified as jobs. When there is a substantial degree of similarity between different jobs, they are grouped together and labeled a cluster. The jobs found to be dissimilar from jobs within a cluster are labeled independent jobs. In this way, the basic structure of a career area or utilization field is described in terms of the jobs performed and their relationship to each other. This analysis provides a foundation for evaluating other aspects within a career ladder or utilization field, such as personnel classification, AFR 36-1 and AFR 39-1 Specialty Descriptions. In this report, only the part of the incumbents' job dealing with their prefix is analyzed and described.

Job Structure

Based on variations in the combinations of tasks performed, structure analysis identified 5 clusters and 3 independent jobs representing the 753 respondents. Figure 1 illustrates the relative size of the clusters and independent jobs within the total sample. The number of personnel in each group (N) is also shown.

TABLE 2

AFSC BY PREFIX DISTRIBUTION OF SURVEY SAMPLE
(PERCENT MEMBERS RESPONDING)

	<u>AFSC</u>	<u>PERCENT OF SAMPLE WITHIN PREFIX</u>		<u>AFSC</u>	<u>PERCENT OF SAMPLE WITHIN PREFIX</u>
ENLISTED	25XXX	65	OFFICERS	14XX	5
D PREFIX	27XXX	31	D PREFIX	15XX	47
(N=29)	73XXX	3	(N=19)	20XX	5
				22XX	21
				25XX	5
ENLISTED	20XXX	7		28XX	5
W PREFIX	25XXX	5		64XX	5
(N=243)	27XXX	15		67XX	5
	45XXX	2			
	55XXX	2	OFFICERS	14XX	5
	62XXX	2	C PREFIX	17XX	2
	64XXX	3	(N=462)	18XX	7
	67XXX	10		22XX	10
	70XXX	31		25XX	26
	73XXX	10		26XX	2
	906XX	10		28XX	1
	91XXX	2		40XX	3
				60XX	3
				62XX	1
				64XX	3
				66XX	2
				67XX	1
				70XX	3
				73XX	7
				80XX	14
				82XX	2
				90XX	6
				91XX	2

* Columns may not add to 100 percent due to rounding

TABLE 3
DISTRIBUTION OF MAJCOM BY SURVEY SAMPLE*

MAJCOM	OFFICER		ENLISTED	
	PERCENT OF ASSIGNED (N=783)	PERCENT OF SAMPLE (N=481)	PERCENT OF ASSIGNED (N=468)	PERCENT OF SAMPLE (N=272)
AFMPC	4	5	-	-
USAFE	3	4	10	11
AFAFC	1	1	4	7
AFSC	2	1	3	1
ATC	3	2	7	8
HQ USAF	2	2	-	-
MAC	27	31	21	22
PACAF	5	5	7	9
SAC	11	11	13	10
TAC	5	6	7	7
AFCC	13	13	13	11
AFSPACECOM	2	2	3	1
AFOMS	2	2	-	2
OTHER	19	14	11	10

* Percentages may not add to 100 percent due to rounding
 - Less than 1 percent

SPECIALTY JOBS (N= 753)

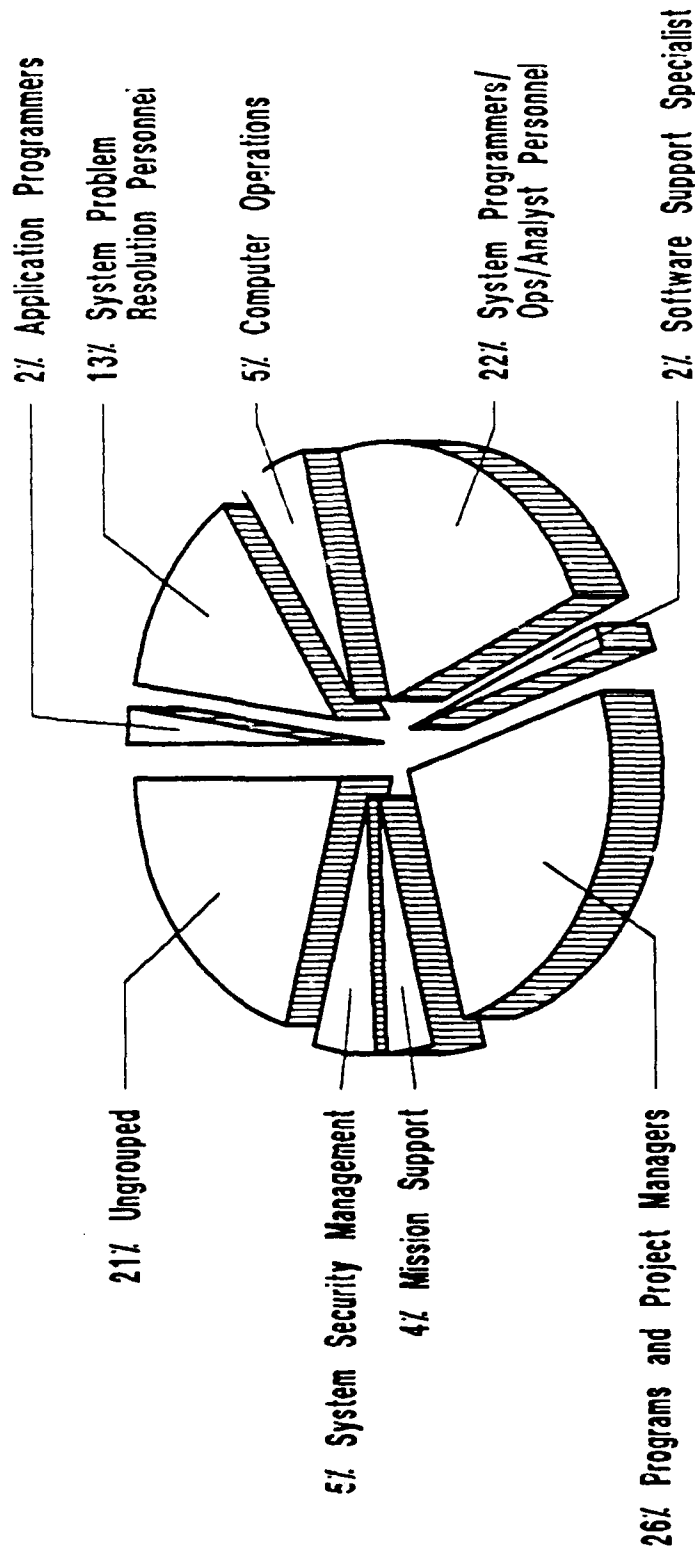

Figure 1

OFFICER C PREFIX - AUTOMATED FUNCTIONAL APPLICATIONS ANALYST
OFFICER D PREFIX - AUTOMATED SYSTEMS PROGRAMS DESIGNER
ENLISTED D PREFIX - AUTOMATED SYSTEMS PROGRAMMING TECHNICIAN
ENLISTED W PREFIX - AUTOMATED FUNCTIONAL APPLICATIONS ANALYST/MONITOR

- I. APPLICATION PROGRAMMERS (N=17)
- II. SYSTEM PROBLEM RESOLUTION PERSONNEL CLUSTER (N=101)
 - A. Job A (N=42)
 - B. Job B (N=8)
 - C. Job C (N=10)
- III. COMPUTER OPERATIONS CLUSTER (N=40)
 - A. Job A (N=8)
 - B. Job B (N=6)
 - C. Job C (N=6)
 - D. Job D (N=8)
- IV. SYSTEM PROGRAMMERS/OPERATIONS/ANALYST PERSONNEL CLUSTER (N=169)
 - A. Job A (N=33)
 - B. Job B (N=12)
 - C. Job C (N=8)
 - D. Job D (N=16)
 - E. Job E (N=6)
 - F. Job F (N=17)
 - G. Job G (N=61)
 - H. Job H (N=6)
- V. SOFTWARE SUPPORT SPECIALIST (N=12)
- VI. PROGRAMS AND PROJECT MANAGERS CLUSTER (N=194)
 - A. Job A (N=10)
 - B. Job B (N=6)
 - C. Job C (N=9)
 - D. Job D (N=9)
 - E. Job E (N=7)
 - F. Job F (N=13)
 - G. Job G (N=47)
 - H. Job H (17)

VII. MISSION SUPPORT CLUSTER (N=28)

- A. Job A (N=13)
- B. Job B (N=11)

VIII. SYSTEM SECURITY MANAGERS (N=37)

Seventy-nine percent of the total sample is included in the five clusters and three independent jobs. A total of 25 jobs were identified within the clusters. The remaining 21 percent of respondents were personnel whose task performance was too dissimilar to group with any other personnel in the survey sample, which could point to a low utilization within the prefixes.

Group Descriptions

The following paragraphs briefly describe the different jobs identified in the analysis of the C and D Prefix officers, and D and W Prefix enlisted personnel career area. Distribution of Prefix by clusters and independent jobs is found in Table 4, while distribution by rank is found in Table 5. Percent time spent on duties for each group identified is displayed in Table 6. Table 7 shows the percent time spent on prefix-related duties by clusters and independent jobs. Mission Support Personnel and Security System Managers were the lowest of all the clusters and independent jobs in time spent on prefix-related tasks, as compared to other aspects of their jobs. All other clusters and independent jobs have 50 percent or more members reporting more than one-half of their time spent on prefix-related tasks. For a more detailed listing of representative tasks and a summary of background data on these jobs, see Appendix A.

I. APPLICATION PROGRAMMERS (N=17). Members of this group spend 50 percent of their time performing software development and maintenance-related functions. They are mostly concerned with designing, coding, writing, and troubleshooting application software programs. Fourteen out of the 17 are captains, with all members holding a C Prefix. Fifty-three percent of this group holds a 2546 AFSC (Advanced Weather Officer). The average number of tasks performed is 55. Common tasks are:

- Write functional application programs
- Compile or assemble programs
- Determine causes of application system software malfunctions
- Code computer programs in high level compiler languages

TABLE 4

DISTRIBUTION OF PREFIX BY CLUSTERS AND INDEPENDENT JOBS
(PERCENT MEMBERS RESPONDING)*

PREFIX	APPLICATION PROGRAMMERS (N=17)	SYSTEM PROBLEM RESOLUTION PERS CLUSTER (N=101)	COMPUTER OPERATIONS CLUSTER (N=40)	SYSTEM PROGRAMMERS/ OPERATIONS/ANALYST PERSONNEL CLUSTER (N=169)
OFFICERS D PREFIX	-	5	2	2
OFFICERS C PREFIX	88	48	30	46
ENLISTED D PREFIX	6	3	4	9
ENLISTED W PREFIX	6	44	65	42

* Percentages may not add to 100 percent due to rounding
- None in group

TABLE 4 (CONTINUED)

DISTRIBUTION OF PREFIX BY CLUSTERS AND INDEPENDENT JOBS
(PERCENT MEMBERS RESPONDING)*

PREFIX	SOFTWARE SUPPORT	PROGRAMS AND	MISSION SUPPORT	SYSTEM SECURITY
	SPECIALIST (N=12)	PROJECT MANAGERS CLUSTER (N=194)	CLUSTER (N=28)	MANAGERS (N=37)
OFFICERS D PREFIX	-	3	-	3
OFFICERS C PREFIX	75	88	4	65
ENLISTED D PREFIX	-	2	4	-
ENLISTED W PREFIX	25	8	92	33

* Percentages may not add to 100 percent due to rounding
- None in group

TABLE 5

GRADE DISTRIBUTION BY CLUSTERS AND INDEPENDENT JOBS
(PERCENT MEMBERS RESPONDING)*

	APPLICATION PROGRAMMERS (N=17)	SYSTEM PROBLEM RESOLUTION PERS CLUSTER (N=101)	COMPUTER OPERATIONS CLUSTER (N=40)	SYSTEM PROGRAMMERS/ OPERATIONS/ANALYST PERSONNEL CLUSTER (N=169)
2LT	-	-	-	1
1LT	6	3	-	7
CAPT	82	29	17	31
MAJ	-	15	10	8
LT COL	-	7	5	2
COL AND ABOVE	-	-	-	-
<hr/>				
AB	-	-	-	-
AMN	-	-	-	-
A1C	-	1	-	-
SrA/SGT	-	4	5	1
SSGT	6	9	22	10
TSGT	-	12	13	18
MSGT	6	15	25	19
SMGT	-	5	2	3
CMSGT	-	1	-	-

* Percentages may not add to 100 percent due to rounding
- None in group

TABLE 5 (CONTINUED)

GRADE DISTRIBUTION BY CLUSTERS AND INDEPENDENT JOBS
(PERCENT MEMBERS RESPONDING)*

	SOFTWARE SUPPORT SPECIALIST (N=12)	PROGRAMS AND PROJECT MGRS CLUSTER (N=194)	MISSION SUPPORT CLUSTER (N=28)	SYSTEM SECURITY MANAGERS (N=37)
2LT	-	1	-	3
1LT	-	4	-	8
CAPT	58	31	-	38
MAJ	8	27	4	14
LT COL	8	25	-	5
COL AND ABOVE	-	2	-	-
<hr/>				
AB	-	-	-	-
AMN	-	-	-	-
A1C	-	-	4	-
SrA/SGT	-	-	11	-
SSGT	-	-	25	5
TSGT	-	3	25	11
MSGT	8	4	18	8
SMGT	-	1	14	5
CMSGT	17	3	-	3

* Percentages may add to 100 percent due to rounding

- None in group

TABLE 6

AVERAGE PERCENT TIME SPENT ON DUTIES BY
CLUSTERS AND INDEPENDENT JOBS*

DUTIES	APPLICATION PROGRAMMERS (N=17)	SYSTEM PROBLEM RESOLUTION PERS CLUSTER (N=101)	COMPUTER OPERATIONS CLUSTER (N=40)	SYSTEM PROGRAMMERS/ OPERATIONS/ANALYST PERSONNEL CLUSTER (N=169)
A. PROBLEM RESOLUTION FUNCTIONS	3	31	9	9
B. GENERAL COMMUNICATIONS-COMPUTER FUNCTIONS	2	11	8	7
C. OPERATIONS FUNCTIONS	6	19	32	20
D. PROGRAM AND PROJECT MANAGEMENT FUNCTIONS	6	11	6	11
E. PRODUCTION CONTROL OR SYSTEM MONITORING	3	2	10	4
F. MAGNETIC MEDIA MANAGEMENT FUNCTIONS	-	-	4	1
G. SOFTWARE PLANNING AND DESIGN FUNCTIONS	9	6	6	10
H. SOFTWARE DEVELOPMENT IMPLEMENTATION/ MAINTENANCE FUNCTIONS	50	7	15	19
I. SOFTWARE TESTING & QUALITY ASSURANCE FUNCTIONS	5	1	2	5
J. SYSTEMS DEVELOPMENT FUNCTIONS	14	4	2	8
K. SECURITY FUNCTIONS	-	5	5	4
L. ACQUISITION AND CONTRACTING FUNCTIONS	-	1	-	1
M. SUPPLY AND EQUIPMENT CONTROL FUNCTIONS	1	2	2	1

* Percentages may not add to 100 percent due to rounding

- Less than 1 percent

TABLE 6 (CONTINUED)

AVERAGE PERCENT TIME SPENT ON DUTIES BY
CLUSTERS AND INDEPENDENT JOBS*

DUTIES	SOFTWARE SUPPORT SPECIALIST (N=12)	PROGRAMS AND PROJECT MGRS CLUSTER (N=194)	MISSION SUPPORT CLUSTER (N=28)	SYSTEM SECURITY MANAGERS (N=37)
A. PROBLEM RESOLUTION FUNCTIONS	5	6	7	4
B. GENERAL COMMUNICATIONS-COMPUTER FUNCTIONS	14	11	12	6
C. OPERATIONS FUNCTIONS	20	8	15	12
D. PROGRAM AND PROJECT MANAGEMENT FUNCTIONS	12	42	15	9
E. PRODUCTION CONTROL OR SYSTEM MONITORING	4	-	6	3
F. MAGNETIC MEDIA MANAGEMENT FUNCTIONS	2	-	-	1
G. SOFTWARE PLANNING AND DESIGN FUNCTIONS	14	10	2	3
H. SOFTWARE DEVELOPMENT IMPLEMENTATION/MAINTENANCE FUNCTIONS	6	6	4	6
I. SOFTWARE TESTING AND QUALITY ASSURANCE FUNCTIONS	1	2	-	1
J. SYSTEMS DEVELOPMENT FUNCTIONS	5	5	-	2
K. SECURITY FUNCTIONS	14	2	5	45
L. ACQUISITION AND CONTRACTING FUNCTIONS	2	7	2	3
M. SUPPLY AND EQUIPMENT CONTROL FUNCTIONS	1	2	32	6

* Percentages may not add to 100 percent due to rounding
- Less than 1 percent

TABLE 7

PERCENT TIME SPENT ON PREFIX-RELATED DUTIES
 BY CLUSTERS AND INDEPENDENT JOBS
 (PERCENT MEMBERS RESPONDING)*

<u>PERCENT TIME SPENT</u>	<u>APPLICATION PROGRAMMERS (N=17)</u>	<u>SYSTEM PROBLEM RESOLUTION PERS CLUSTER (N=101)</u>	<u>COMPUTER OPERATIONS CLUSTER (N=40)</u>	<u>SYSTEM PROGRAMMERS/ OPERATIONS/ANALYST PERSONNEL CLUSTER (N=169)</u>
NONE	-	10	12	4
1-10%	-	8	15	4
11-20%	5	7	5	4
21-30%	-	5	3	1
31-40%	-	7	-	5
41-50%	17	5	3	5
51-60%	5	7	7	4
61-70%	11	7	5	13
71-80%	11	12	15	11
81-90%	23	7	17	16
91-100%	29	26	17	33

* Percentages may not add to 100 percent due to rounding
 - None in group

TABLE 7 (CONTINUED)

PERCENT TIME SPENT ON PREFIX-RELATED DUTIES
 BY CLUSTERS AND INDEPENDENT JOBS
 (PERCENT MEMBERS RESPONDING)*

<u>PERCENT TIME SPENT</u>	<u>SOFTWARE SUPPORT SPECIALIST (N=12)</u>	<u>PROGRAMS AND PROJECT MGRS CLUSTER (N=194)</u>	<u>MISSION SUPPORT CLUSTER (N=28)</u>	<u>SYSTEM SECURITY MANAGERS (N=37)</u>
NONE	-	5	25	19
1-10%	24	5	21	19
11-20%	15	6	6	13
21-30%	-	6	-	10
31-40%	-	4	6	2
41-50%	-	6	6	10
51-60%	-	5	6	5
61-70%	24	11	14	2
71-80%	15	13	-	10
81-90%	15	12	6	5
91-100%	7	28	10	5

* Percentages may not add to 100 percent due to rounding

II. SYSTEM PROBLEM RESOLUTION PERSONNEL CLUSTER (N=101). This cluster consists of 101 personnel whose major responsibilities are in the area of problem resolution. Tasks related to tracking, identifying, and resolving system problems are performed by members of this group. Fifty-eight percent are C Prefix officers with 44 percent being enlisted personnel with a W Prefix. A wide range of AFSCs and ranks was found. The average number of tasks performed is 43. Typical tasks performed by System Problem Resolution Personnel are:

- Track status of reported problems
- Determine whether system problems are local or Air Force wide
- Refer systems problems to responsible agencies or persons
- Solicit possible systems problems from users

This cluster accounts for 13 percent of the survey sample. Within this cluster, three jobs were identified. The first, Job A, is the largest (N=42) and accounts for 42 percent of the cluster. This job is more focused on performing system-problem tasks than the other jobs within the cluster. Forty-five percent are W Prefix enlisted personnel and 50 percent C Prefix officers. Job B (N=8) personnel worked system problem resolution; however, a large proportion (42 percent) of their time is spent performing computer operations tasks. Ninety percent of this group were W Prefix personnel. The last jobs in this cluster, Job C (N=10), spend their time on tasks evenly split between computer operations tasks (21 percent) and system problem resolution (20 percent). This group is made up of three each of D and W Prefix enlisted and C Prefix officers, with one remaining officer holding a D Prefix.

III. COMPUTER OPERATIONS CLUSTER (N=40). The 40 members of this cluster grouped together based on their time shared in the operations function, performing tasks related to loading programs, aligning files on disc, and reviewing computer output. Sixty-five percent of this group are W Prefix enlisted personnel, with 30 percent being C Prefix officers. This cluster has a wide range of AFSCs and ranks. The average number of tasks performed is 50. Typical tasks performed are:

- Initialize processing, such as batched, on-line, or off-line
- Analyze console displays or system printouts
- Transfer programs or data from one media to another media
- Load programs or data from cards, disks, or tapes

This cluster accounts for 5 percent of the survey sample. Within this cluster, four jobs were identified. The first job, Job A, contained eight respondents dividing their time between performing computer operations and programming related tasks, such as coding and writing job control runstreams. This job contained five C Prefix officers and three W Prefix enlisted personnel. In the second job, Job B (N=6), five out of the six are W Prefix airmen, performing system monitoring tasks, as well as computer operations tasks. The third job, Job C (N=6), is involved with all aspects of the upkeep for the magnetic media. Four out of the six were W Prefix airmen. The eight members of the last job within this cluster, Job D, are doing tasks related to the management of the data system, such as reviewing, maintaining, and monitoring the system for security, as well as operations control. Six out of the eight were W Prefix airmen, while the remaining two were C Prefix officers.

IV. SYSTEM PROGRAMMERS/OPERATIONS/ANALYST PERSONNEL CLUSTER (N=169). The personnel in this cluster grouped together based on time spent and performance of common computer operations, software development and maintenance functions. Fifty-six percent are C Prefix officers, while 42 percent are enlisted holding a W Prefix. The major concentration of officers in this cluster hold AFSC 25XX (17 percent). Thirty-one percent of the cluster hold the rank of captain. Enlisted personnel are represented by a wide range of AFSCs and rank. Personnel in this cluster performed an average of 166 tasks, the highest number in all the clusters. Common tasks performed by this group are:

- Analyze data base requirements
- Debug computer programs
- Determine causes to abnormal program halts
- Determine cause of application system software malfunctions
- Load programs or data from cards, disks, or tapes

This cluster accounts for 22 percent of the survey sample. Within this cluster, eight jobs were identified. Job A (N=33) accounts for 20 percent of the cluster, with 72 percent C Prefix officers. Job A personnel are involved in system programming and performing tasks related to coding, designing, and debugging computer programs. The second and third jobs, Job B (N=12) and Job C (N=8), members performed very similar tasks related to computer operations, although slight differences were found in that Job B personnel spend more time involved in the area of computer functional requirements. Job B contains mostly enlisted W Prefix (81 percent), while Job C consists of W Prefix enlisted personnel (50 percent) and C Prefix officers (26 percent). Job D (N=16) personnel spend the majority of their time (37 percent) in computer operations related tasks; however, tasks related to problem solving and system maintenance are also performed. The majority of this group are W Prefix airmen (63 percent). Job E (N=6) is similar to Job B and Job C in that the group also performs computer operations tasks; the difference found among these three groups is in the time spent on the tasks. All six of the personnel in this job are W prefix airmen. The next job, Job F (N=17), personnel

are involved in network support. The respondents work with the users in the development of system communications requirements and hardware availability. The personnel found in this job are W Prefix airmen (36 percent) and C Prefix officers (54 percent). Analyzing communication-computer systems and establishing and reviewing data base requirements are the major functions performed by members of Job G (N=61). This job accounts for 39 percent of this cluster, and is made up of 32 percent W Prefix airmen and 60 percent C Prefix officers. The last job in this cluster, Job H (N=6), consists of personnel who are responsible for software testing and determining software malfunctions and discrepancies. Three out of the six are airmen, and the remaining three are officers.

V. SOFTWARE SUPPORT SPECIALIST (N=12). The 12 personnel in this group perform a wide range of tasks related to operations; however, they spend an equal amount of time in software planning, general communications-computer functions, as well as security. Nine out of the 12 are captains holding a C Prefix, 3 out of the 12 are enlisted with a W Prefix. Three of the C Prefix officers hold AFSC 8224. The average number of tasks performed by this group is 48. Common tasks performed are:

- Recommend selection of commercially available software packages
- Design or provide input to data-base specifications
- Evaluate advances in communications-computer system technology having possible application to mission
- Assist functional users in defining requirements

VI. PROGRAMS AND PROJECT MANAGERS CLUSTER (N=194). This cluster of 194 personnel is the largest cluster identified. These personnel perform tasks primarily related to the development, evaluation, and management of established as well as future programs. Eighty-eight percent are officers holding the C Prefix, with 22 percent having the 80XX AFSCs. Common tasks for this group are:

- Prepare justification for programs, projects or systems
- Evaluate effects of funding or manpower cuts on programs or projects
- Coordinate requirements with agencies or contractors for system, facilities or equipment
- Determine priority of programs or project requirements

This cluster accounts for 26 percent of the total survey sample. Within this cluster, eight jobs were identified. Members of Job A (N=10) focused on standards and specifications for system-related programs. Nine out of the 10 personnel are officers holding the C Prefix. Job B (N=6) personnel perform tasks related to coordinating programs and projects, dealing mostly with the milestones and scheduling of projects. Four are C Prefix officers, with the remaining two being enlisted holding a W Prefix. The nine personnel in Job C

(N=9) were all C Prefix officers who were involved as liaison officers in defining requirements for services from the user. Eight of the personnel found in Job D (N=9) are C Prefix officers, with the remaining one holding a W Prefix. The main job of members of this group involves working on software-configurations and managing new software-related programs. Job E (N=7) personnel spend their time on tasks related to budgeting and the responsibility of funds and manpower requirements. Six are C Prefix officers and the remaining one, D Prefix, is enlisted. Job emphasis and tasks performed by Job F (N=13) personnel relate to the development of new programs. They perform such tasks as writing or providing input to Statement of Work (SOW), Statement of Need (SON), or Mission Element Need Statement (MEN). This job is performed by officers holding the C Prefix. Job G (N=47) is the core within the cluster and accounts for 25 percent of the cluster's members. Tasks performed by members of this group are mostly related to project and program management tasks. Ninety-one percent are C Prefix officers. The last job identified in this cluster is Job H (N=17), with 16 out of the 17 consisting of officers holding the C Prefix. They perform tasks strictly concentrated in the areas of acquisition and contracting.

VII. MISSION SUPPORT CLUSTER (N=28). Mission Support Personnel are responsible for the acquisition and control of all supplies and equipment. Out of the 28 personnel in this cluster, 26 were enlisted carrying the W Prefix. Twenty-one are classified in AFSC 702XX. Average number of tasks performed is 49. Common tasks are:

- Maintain equipment custodian accounts
- Inspect supplies or equipment
- Monitor equipment installation
- Prepare procurement documents, such as purchase requests

This cluster accounts for 3 percent of the survey sample. Two jobs were found in this cluster. Members of Job A (N=13) are doing three times as many tasks as Job B (N=11) members and are among the senior ranks. Job A personnel spend their time in supply and equipment control-related tasks; they are also involved in the area of operations and computer functions. Job B personnel are more concentrated in the area of mission support with tasks related to inventory of equipment, inspecting, and tracking supplies or equipment. Nine out of the eleven respondents in Job B are overseas and are of lower rank than Job A.

VIII. SYSTEM SECURITY MANAGERS (N=37). The 37 members of this independent job spend 45 percent of their time in security functions-related tasks. They are responsible for such tasks as conducting security inspections, monitoring, and administering system security programs. Twelve of the thirty-seven are

enlisted, all carrying the W Prefix, covering numerous AFSCs. Rank concentration is at the TSgt level. The officers in the group all carry the C Prefix, except one, with the majority being captains. An average of 52 tasks are performed; common tasks are.

- Conduct threat or vulnerability assessment of system
- Brief or debrief personnel on security procedures
- Monitor terminal access through physical or password means
- Administer security programs

DAFSC PREFIX COMPARISONS

Comparisons were made among the four prefixes, with several trends reported. The small numbers of respondents within the prefixes resulted in comparisons somewhat general in nature. Within the prefix sample, the C Prefix officers are heavily involved with plans and programs-related tasks, while the D Prefix officer, W Prefix and D Prefix enlisted personnel are more involved with operational functions. Tables 8 through 11 show representative tasks performed by the four prefixes. Very few tasks were noted as being performed by one-half of the respondents in any of the four groups, which could indicate either a large job diversity or underutilization of personnel. Table 12 shows the percent time spent on prefix-related duties by the D and C Prefix officers and D and W Prefix enlisted personnel. A majority of D and C Prefix officers and D and W Prefix enlisted personnel are spending 50 percent or more on prefix-related tasks, with about 10 percent of all respondents reporting spending very little time on prefix-related work.

WRITE-IN COMMENTS

Respondents are invited to write in any comments related to their job on the back of their inventory booklet. Several comments noted were related to the assignment of prefixes. Typical complaints are that the job performed is not prefix related, with very few tasks in the inventory related to their jobs. Several commented on the fact that they were making attempts to have the prefix removed, while others are not even aware that they had one. Many respondents commented the only computer-related work they perform is using the computer as a "word processor." These comments are supported by observations made during the job inventory development phase of this project.

TABLE 8
 REPRESENTATIVE TASKS PERFORMED BY C PREFIX OFFICERS

TASKS	PERCENT MEMBERS PERFORMING (N=462)
Conduct or participate in program management meetings or working groups	53
Justify funds for programs	44
Observe contractor demonstrations	43
Identify requirements for new technology or prototypes	42
Identify shortfalls in onhand or programmed systems or equipment for meeting future mission needs	40
Report status of system problems resolution to user	38
Evaluate functional descriptions	37
Evaluate effect of funding or manpower cuts on program and project	33
Review requirements documents, such as SOW, PSP, SORD, MEN, SON, or ROC	30

TABLE 9

REPRESENTATIVE TASKS PERFORMED BY D PREFIX OFFICERS

<u>TASKS</u>	<u>PERCENT MEMBERS PERFORMING (N=19)</u>
Assist computer programmers in resolving user problems	79
Validate existence of system problems	63
Analyze console displays or system printouts	58
Solicit possible systems problems from users	53
Provide higher headquarters with performance, status, or configuration reports	53
Identify or isolate programs causing stoppages	42
Classify documents, materials, or info	42
Analyze or identify system hardware failure trends	42
Monitor access to security controlled or restricted areas	32
Mark, downgrade, or page check classified document	32

TABLE 10

REPRESENTATIVE TASKS PERFORMED BY D PREFIX AIRMEN

<u>TASKS</u>	<u>PERCENT MEMBERS PERFORMING (N=29)</u>
Compile or assemble programs	66
Debug computer programs	59
Perform character conversion using character conversion charts, such as ASCII to BCD or ASCII to EBCDIC	55
Code computer programs in high level compiler languages	55
Review computer software functional descriptions	55
Draft or write operational procedures	52
Investigate customer service complaints	52
Develop inputs to programming documents	52
Draft or write functional procedures	52
Provide technical information for establishing baseline requirements for programs	41

TABLE 11

REPRESENTATIVE TASKS PERFORMED BY W PREFIX AIRMEN

<u>TASKS</u>	<u>PERCENT MEMBERS PERFORMING (N=245)</u>
Refer systems problems to responsible agencies or persons	73
Troubleshoot minor problem over the phone	63
Report status of system problem resolution or persons	52
Assist functional users in preparation of difficulty or trouble reports	51
Track status of reported problems	49
Edit input or output data	42
Check operational status of equipment	41
Assist functional users in defining requirements	41
Power up or power down communication-computer systems equipment	40
Input or retrieve data using remote inquiry units	30

TABLE 12

PERCENT TIME SPENT ON PREFIX-RELATED
DUTIES BY PREFIXES
(PERCENT MEMBERS RESPONDING)*

<u>PERCENT TIME SPENT</u>	<u>D PREFIX OFFICERS (N=19)</u>	<u>C PREFIX OFFICERS (N=462)</u>	<u>W PREFIX ENLISTED (N=243)</u>	<u>D PREFIX ENLISTED (N=29)</u>
NONE	10	7	14	11
1-10%	-	9	12	11
11-20%	15	8	4	3
21-30%	11	6	4	-
31-40%	5	5	4	7
41-50%	-	7	5	3
51-60%	4	5	5	3
61-70%	21	10	8	3
71-80%	26	11	9	11
81-90%	4	10	12	24
91-100%	4	23	23	24

* Percentages may not add to 100 percent due to rounding
- None in group

JOB SATISFACTION

An examination of the C and D Prefix officers and D and W Prefix airmen job satisfaction indicators provides some understanding of factors which may affect the job performance of these personnel groups. Job satisfaction indicators for members of the five clusters and three independent jobs are shown in Table 13. All the groups found their jobs interesting, with a high sense of accomplishment, although most feel their training and talent are not being well used. Computer Operator personnel have the lowest indicators for utilization of training, while Application Programmers have the lowest for utilization of talents.

Job satisfaction indicators for the D and W Prefix airmen personnel were compared to AFSC 491XX Communication-Computer System Operations or Programmers surveyed in 1988. Table 14 shows overall job satisfaction for these groups. Overall job satisfaction was slightly higher in the area of job interest, sense of accomplishment, and utilization of talent, while utilization of training was somewhat lower. Table 15 shows the overall job satisfaction indicators for the C and D Prefix officers compared to the AFSC 49XX Communication-Computer System Officer surveyed in 1988. Job satisfaction indicators were also slightly higher for the prefix personnel in the present study. Forty percent of the total respondents within the prefixes indicated their training is not well utilized.

PERSONNEL UTILIZATION

Occupational survey data are also used to examine classification issues. AFR 36-1 and AFR 39-1 Specialty Descriptions are intended to give a description of the responsibilities of the personnel holding prefixes. AFR 36-1 (C-9) Atch 2, dated 30 April 1988, was applicable to the C and D Prefix officer. AFR 39-1 (C-2) Atch 2, dated 31 October 1988, was applicable to the D and W Prefix airmen.

We compared 36-1 and 39-1 job descriptions to the tasks performed by the survey sample. Both manuals appear to satisfactorily describe the work performed by prefix holders working in prefix-related jobs. Several factors indicated numerous individuals may have been inappropriately awarded their respective prefixes. These include: 1) 55 cases initially lost to the sample because they performed too few prefix-related tasks, 2) 10 percent respondents performing no prefix-related tasks, 3) 115 out of the 753 respondents did not cluster with the others, 4) 44 percent reporting their training was not well utilized, 5) many write-in comments indicated a prefix was not needed, and 6) during the initial interviewing process, many comments indicated that no prefix-related tasks were being performed.

TABLE 13

JOB SATISFACTION INDICATORS AMONG CLUSTERS AND INDEPENDENT JOBS
(PERCENT MEMBERS RESPONDING)*

	APPLICATION PROGRAMMERS (N=17)	SYSTEM PROBLEM RESOLUTION PERS CLUSTER (N=101)	COMPUTER OPERATIONS CLUSTER (N=40)	SYSTEM PROGRAMMERS/ OPERATIONS/ANALYST PERSONNEL CLUSTER (N=169)
<u>JOB INTEREST:</u>				
INTERESTING	94	79	77	93
SO-SO	6	12	15	5
DULL	-	9	7	2
<u>UTILIZATION OF TALENT:</u>				
VERY WELL	29	21	27	28
FAIRLY WELL	71	61	57	67
NOT WELL	-	18	15	5
<u>SENSE OF ACCOMPLISHMENT:</u>				
SATISFIED	94	79	72	86
NEITHER	-	6	2	4
DISSATISFIED	6	15	25	10
<u>UTILIZATION OF TRAINING:</u>				
VERY WELL	6	11	2	8
FAIRLY WELL	76	47	38	48
NOT WELL	18	42	60	41

* Percentages may not add to 100 percent due to rounding
- Less than 1 percent

TABLE 13 (CONTINUED)

JOB SATISFACTION INDICATORS AMONG CLUSTERS AND INDEPENDENT JOBS
(PERCENT MEMBERS RESPONDING)*

	SOFTWARE SUPPORT SPECIALIST (N=12)	PROGRAMS AND PROJECT MANAGERS CLUSTER (N=194)	MISSION SUPPORT CLUSTER (N=28)	SYSTEM SECURITY MANAGERS (N=37)
<u>JOB INTEREST:</u>				
INTERESTING	100	86	79	70
SO-SO	-	8	11	16
DULL	-	5	11	14
<u>UTILIZATION OF TALENT:</u>				
VERY WELL	33	27	25	16
FAIRLY WELL	67	58	57	16
NOT WELL	-	14	18	14
<u>SENSE OF ACCOMPLISHMENT:</u>				
SATISFIED	92	77	71	65
NEITHER	8	6	14	8
DISSATISFIED	0	16	14	27
<u>UTILIZATION OF TRAINING:</u>				
VERY WELL	25	9	18	16
FAIRLY WELL	67	50	54	41
NOT WELL	8	39	29	43

* Percentages may not add to 100 percent due to rounding
- Less than 1 percent

TABLE 14

COMPARISON OF D AND W PREFIX AIRMEN
 JOB SATISFACTION INDICATORS
 (PERCENT MEMBERS RESPONDING)*

	D PREFIX (N=29)	W PREFIX (N=243)	491XX COMP SAMPLE (N=2,673)
<u>JOB INTEREST:</u>			
INTERESTING	76	84	62
SO-SO	3	10	18
DULL	21	5	18
<u>UTILIZATION OF TALENT:</u>			
VERY WELL	24	28	11
FAIRLY WELL	55	58	58
NOT WELL	21	13	31
<u>SENSE OF ACCOMPLISHMENT:</u>			
SATISFIED	72	81	57
NEITHER	3	4	13
DISSATISFIED	24	14	29
<u>UTILIZATION OF TRAINING:</u>			
VERY WELL	6	17	10
FAIRLY WELL	38	40	56
NOT WELL	62	42	34

* Columns may not add to 100 percent due to rounding

TABLE 15

COMPARISON OF D AND C PREFIX OFFICERS
 JOB SATISFACTION INDICATORS
 (PERCENT MEMBERS RESPONDING)*

	D PREFIX (N=19)	w PREFIX (N=462)	49XX COMP SAMPLE (N=4,145)
<u>JOB INTEREST:</u>			
INTERESTING	84	83	80
SO-SO	16	9	10
DULL	0	7	10
<u>UTILIZATION OF TALENT:</u>			
VERY WELL	16	20	22
FAIRLY WELL	74	63	57
NOT WELL	11	16	22
<u>SENSE OF ACCOMPLISHMENT:</u>			
SATISFIED	79	76	70
NEITHER	5	7	6
DISSATISFIED	16	17	24
<u>UTILIZATION OF TRAINING:</u>			
VERY WELL	11	6	11
FAIRLY WELL	74	52	47
NOT WELL	16	39	40

* Columns may not add to 100 percent due to rounding

Since it is unclear which prefix assignments are valid, it is quite difficult to relate which descriptions found in AFR 36-1 and 39-1 are appropriate, which ones are not, and which need to be added. Until these positions are regulated, changes to the Specialty Descriptions and training needs should be put on hold.

IMPLICATIONS

This survey was conducted primarily to obtain current information as to the jobs being performed by the C and D Prefix officers and D and W Prefix enlisted personnel. The job structure analysis shows most members of the survey sample are performing prefix-related tasks, although percent members performing common tasks were somewhat low. The majority of the respondents are spending time on prefix-related duties; however, a large number are performing no prefix-related tasks or very few tasks. Job satisfaction indicators were low for utilization of training and utilization of talent, while job interest and sense of accomplishment were high.

Overall, the analysis revealed that some personnel who hold a prefix are being utilized in positions requiring prefixes, while others indicated they were not performing prefix-related work at all. A position-by-position audit would be helpful in determining prefix positions and jobs being performed by the prefix personnel. Getting a handle on this will pave the way for a more in-depth review of the 36-1 and 39-1 Specialty Descriptions, as well as establishing training programs.

APPENDIX A

TABLE A1
APPLICATION PROGRAMMER
(ST271)

Group Size: 17	Percent D Prefix Officers: 0
Average Time in Present Job: 26	Percent C Prefix Officers: 88
Average Number Tasks Performed: 55	Percent D Prefix Airmen: 6
Percent of Sample: Less than 1	Percent W Prefix Airmen: 6

The following are in descending order by percent members performing:

TASKS	PERCENT MEMBERS PERFORMING
H346 Code computer programs in high level compiler languages	94
H350 Compile or assemble programs	88
H349 Code job control run streams in job control languages	82
H432 Write job control run streams	82
H431 Write functional applications programs	65
J472 Analyze computer applications software for modifications	65
H353 Design error handling routines	59
G286 Design or provide input to input or output formats	53
J478 Design computer applications software to fulfill user requirements	47
H427 Write applications programs utilizing data manipulation languages	41
J481 Determine cause of applications system software malfunctions	41
H348 Code data base access routines	41

NOTE: Percent of Prefix may not equal 100 percent due to rounding

TABLE A2

SYSTEM PROBLEM RESOLUTION PERSONNEL CLUSTER I
(ST058)

Group Size: 101	Percent D Prefix Officers: 5
Average Time in Present Job: 24	Percent C Prefix Officers: 48
Average Number Tasks Performed: 43	Percent D Prefix Airmen: 3
Percent of Sample: 13	Percent W Prefix Airmen: 44

The following are in descending order by percent members performing:

TASKS	PERCENT MEMBERS PERFORMING
A9 Refer systems problems to responsible agencies or persons	92
A1 Assist computer programmer in resolving user problems	82
A3 Classify problems as hardware related, software related, or user lack of knowledge related	78
A13 Track status of reported problems	74
A12 Solicit possible systems problems from users	73
A11 Research or review manuals, documentation, or technical publications to aid in problem isolation or correction	72
A15 Validate existence of systems problems	72
A10 Report status of systems problem resolution to users	72
A14 Troubleshoot minor user problems over the phone	71
A7 Identify or isolate programs causing stoppages	49
C66 Copy disk packs, diskettes, or tapes	41
B19 Check operational status of equipment	32

NOTE: Percent of Prefix may not equal 100 percent due to rounding

TABLE A3
 CLUSTER I/JOB A
 (ST208)

Group Size: 42	Percent D Prefix Officers: 2
Average Time in Present Job: 22	Percent C Prefix Officers: 50
Average Number Tasks Performed: 49	Percent D Prefix Airmen: 2
Percent of Sample: 1	Percent W Prefix Airmen: 45

The following are in descending order by percent members performing:

<u>TASKS</u>	<u>PERCENT MEMBERS PERFORMING</u>
A9 Refer systems problems to responsible agencies or persons	95
A12 Solicit possible systems problems from users	93
A15 Validate existence of systems problems	93
A13 Track status of reported problems	90
A14 Troubleshoot minor user problems over the phone	90
A2 Assist functional users in preparation of difficulty or trouble reports	83
A4 Determine methods of continuing operations while problems are being resolved or during communications upgrades	76
A5 Determine whether systems problems are local or Air Force wide	71
A7 Identify or isolate programs causing stoppages	60
A8 Perform site assistance visits	50
B29 Evaluate quality of service provided to users	48
A6 Distribute system advisory notices	36

NOTE: Percent of Prefix may not add to 100 percent due to rounding

TABLE A4
 CLUSTER I/JOB B
 (ST315)

Group Size: 8	Percent D Prefix Officers: 0
Average Time in Present Job: 20	Percent C Prefix Officers: 13
Average Number Tasks Performed: 54	Percent D Prefix Airmen: 0
Percent of Sample: Less than 1	Percent W Prefix Airmen: 90

The following are in descending order by percent members performing:

<u>TASKS</u>	<u>PERCENT MEMBERS PERFORMING</u>
A10 Report status of systems problem resolution to users	100
A14 Troubleshoot minor user problems over the phone	88
A3 Classify problems as hardware related, software related, or user lack of knowledge related	88
C78 Explain networking systems concepts to users	75
C68 Determine corrective action for identified hardware problems	75
C95 Load programs or data from cards, disks, or tapes	75
C120 Power up or power down communications-computer systems equipment	75
C135 Transfer programs or data from one media to another media	75
A13 Track status of reported problems	75
C132 Set or reset computer time clocks	75
C85 Interpret indicating lights on peripheral equipment	63
A4 Determine methods of continuing operations while problems are being resolved or during communications upgrades	63

NOTE: Percent of Prefix may not add to 100 percent due to rounding

TABLE A5
 CLUSTER I/JOB C
 (5T254)

Group Size: 10	Percent D Prefix Officers: 30
Average Time in Present Job: 25	Percent C Prefix Officers: 30
Average Number Tasks Performed: 65	Percent D Prefix Airmen: 10
Percent of Sample: Less than 1	Percent W Prefix Airmen: 30

The following are in descending order by percent members performing:

<u>TASKS</u>	<u>PERCENT MEMBERS PERFORMING</u>
A11 Research or review manuals, documentation, or technical publications to aid in problem isolation or correction	100
A1 Assist computer programmer in resolving user problems	100
A3 Classify problems as hardware related, software related, or user lack of knowledge related	100
A15 Validate existence of systems problems	90
A12 Solicit possible systems problems from users	90
A13 Track status of reported problems	90
A10 Report status of systems problem resolution to users	90
C66 Copy disk packs, diskettes, or tapes	80
K553 Monitor access to secure, controlled, or restricted areas	80
A4 Determine methods of continuing operations while problems are being resolved or during communications upgrades	80
K568 Schedule classified material for destruction	70
C54 Analyze console displays or system printouts	70

NOTE: Percent of Prefix may add to 100 percent due to rounding

TABLE A6
COMPUTER OPERATIONS PERSONNEL CLUSTER II
(ST066)

Group Size: 40	Percent D Prefix Officers: 2
Average Time in Present Job: 32	Percent C Prefix Officers: 30
Average Number Tasks Performed: 50	Percent D Prefix Airmen: 4
Percent of Sample: 1	Percent W Prefix Airmen: 65

The following are in descending order by percent members performing:

<u>TASKS</u>	<u>PERCENT MEMBERS PERFORMING</u>
C54 Analyze console displays or system printouts	83
C66 Copy disk packs, diskettes, or tapes	80
C135 Transfer programs or data from one media to another media	75
C81 Initialize processing, such as batched job, on-line, or off-line	58
C95 Load programs or data from cards, disks, or tapes	55
E249 Maintain integrity of files on disc	53
E241 Align files on disc	50
C83 Input or retrieve data using remote inquiry units	43
C93 Label magnetic media externally	40
H357 Determine data base currency or accuracy	35
C130 Review computer output products for compliance with standards or specifications	35
C120 Power up or power down communications-computer systems equipment	35

NOTE: Percent of Prefix may not add to 100 percent due to rounding

TABLE A7

CLUSTER II/JOB A
(ST248)

Group Size: 8	Percent D Prefix Officers: 0
Average Time in Present Job: 18	Percent C Prefix Officers: 63
Average Number Tasks Performed: 55	Percent D Prefix Airmen: 0
Percent of Sample: Less than 1	Percent W Prefix Airmen: 38

The following are in descending order by percent members performing:

<u>TASKS</u>	<u>PERCENT MEMBERS PERFORMING</u>
C54A Analyze console displays or system printouts	100
C66 Copy disk packs, diskettes, or tapes	100
C81 Initialize processing, such as batched job, on-line, or off-line	88
H352 Debug computer programs	88
C135 Transfer programs or data from one media to another media	88
H432 Write job control run streams	75
H386 Maintain source code listings	75
H349 Code job control run streams in job control languages	63
H339 Analyze job streams	63
H350 Compile or assemble programs	63
H346 Code computer programs in high level compiler languages	50
H429 Write data base run streams utilizing data base routines, such as Query Language Processors (QLP)	50

NOTE: Percent of Prefix may not add to 100 percent due to rounding

TABLE A8
 CLUSTER II/JOB B
 (ST0325)

Group Size: 6	Percent of D Prefix Officers: 0
Average Time in Present Job: 28	Percent of C Prefix Officers: 34
Average Number Tasks Performed: 29	Percent of D Prefix Airmen: 0
Percent of Sample: Less than 1	Percent of W Prefix Airmen: 68

The following are in descending order by percent members performing:

<u>TASKS</u>	<u>PERCENT MEMBERS PERFORMING</u>
C76 Enter data via console	100
E247 Edit input or output data	100
E242 Assemble input or output data	100
C54 Analyze console displays or system printouts	100
C135 Transfer programs or data from one media to another media	83
C66 Copy disk packs, diskettes, or tapes	83
B38 Perform calculations within a numbering system, other than decimal, using electronic means	83
E241 Align files on disc	67
E249 Maintain integrity of files on disc	50
C83 Input or retrieve data using remote inquiry units	50
C106 Monitor data flow	33
E256 Review disc directory	33

NOTE: Percent of Prefix may not add to 100 percent due to rounding

TABLE A9
 CLUSTER II/JOB C
 (ST0352)

Group Size: 6	Percent of D Prefix Officers: 17
Average Time in Present Job: 64	Percent of C Prefix Officers: 0
Average Number Tasks Performed: 61	Percent of D Prefix Airmen: 17
Percent of Sample: Less than 1	Percent of W Prefix Airmen: 67

The following are in descending order by percent members performing:

<u>TASKS</u>	<u>PERCENT MEMBERS PERFORMING</u>
C130 Review computer output products for compliance with standards or specifications	100
C93 Label magnetic media externally	100
C125 Punch cards	83
C111 Mount or dismount magnetic media	83
C87 Interpret or verify cards visually	83
F266 File magnetic media	83
C79 Format magnetic media	83
E245 Develop tape or disc management policies	83
F259 Clean magnetic media	83
C94 Label magnetic media internally	67
C112 Notify affected personnel, such as supervisors or remote users, of machine failures or downtime	67
F262 Degauss magnetic media	67

NOTE: Percent of Prefix may not add to 100 percent due to rounding

TABLE A10
 CLUSTER II/JOB D
 (ST257)

Group Size: 8	Percent of D Prefix Officers: 0
Average Time in Present Job: 34	Percent of C Prefix Officers: 26
Average Number Tasks Performed: 59	Percent of D Prefix Airmen: 0
Percent of Sample: Less than 1	Percent of W Prefix Airmen: 76

The following are in descending order by percent members performing:

<u>TASKS</u>	<u>PERCENT MEMBERS PERFORMING</u>
E247 Edit input or output data	100
K552 Mark, downgrade, or page check classified documents	100
K553 Monitor access to secure, controlled, or restricted areas	88
E242 Assemble input or output data	88
C81 Initialize processing, such as batched job, on-line, or off-line	88
C135 Transfer programs or data from one media to another media	88
C83 Input or retrieve data using remote inquiry units	75
G284 Design or provide input to data base specifications	75
E249 Maintain integrity of files on disc	75
C80 Identify tape failures	75
K523 Classify documents, materials, or information	63
K532 Declassify classified magnetic storage devices or computer listings	50

NOTE: Percent of Prefix may not add to 100 percent due to rounding

TABLE A11
 SYSTEM PROGRAMMER/OPERATIONS/ANALYST CLUSTER III
 (ST083)

Group Size: 169	Percent of D Prefix Officers: 2
Average Time in Present Job: 31	Percent of C Prefix Officers: 46
Average Number Tasks Performed: 166	Percent of D Prefix Airmen: 9
Percent of Sample: 22	Percent of W Prefix Airmen: 42

The following are in descending order by percent members performing:

TASKS	PERCENT MEMBERS PERFORMING
A14 Troubleshoot minor user problems over the phone	87
A9 Refer systems problems to responsible agencies or persons	85
C54 Analyze console displays or system printouts	78
G278 Assist functional users in defining requirements	68
H356 Determine causes to abnormal program halts	63
C73 Draft or write operations procedures	62
H393 Participate with programmers in testing or debugging programs	61
H352 Debug computer programs	59
H409 Review computer software functional descriptions	57
J481 Determine cause of applications system software malfunctions	55
G276 Analyze data base requirements	54
C55 Analyze or identify system or hardware failure trends	53

NOTE: Percent of Prefix may not add to 100 percent due to rounding

TABLE A12
 CLUSTER III/JOB A
 (ST262)

Group Size: 33	Percent of D Prefix Officers: 0
Average Time in Present Job: 33	Percent of C Prefix Officers: 72
Average Number Tasks Performed: 108	Percent of D Prefix Airmen: 18
Percent of Sample: Less than 1	Percent of W Prefix Airmen: 9

The following are in descending order by percent members performing:

TASKS	PERCENT MEMBERS PERFORMING
H352 Debug computer programs	100
H350 Compile or assemble programs	88
H340 Analyze program dumps	88
H346 Code computer programs in high level compiler languages	85
H386 Maintain source code listings	82
H339 Analyze job streams	79
H432 Write job control run streams	76
H355 Desk check programs	76
J472 Analyze computer applications software for modifications	76
H353 Design error handling routines	76
H426 Review source code listings	73
C93 Label magnetic media externally	73
H371 Draft or write program maintenance manuals	70

NOTE: Percent of Prefix may not add to 100 percent due to rounding

TABLE A13
 CLUSTER III/JOB B
 (ST282)

Group Size: 12	Percent of D Prefix Officers: 8
Average Time in Present Job: 40	Percent of C Prefix Officers: 8
Average Number Tasks Performed: 112	Percent of D Prefix Airmen: 0
Percent of Sample: Less than 1	Percent of W Prefix Airmen: 81

The following are in descending order by percent members performing:

<u>TASKS</u>	<u>PERCENT MEMBERS PERFORMING</u>
G279 Assist systems analysts in interpreting functional requirements	92
G278 Assist functional users in defining requirements	83
A2 Assist functional users in preparation of difficulty or trouble reports	83
A8 Perform site assistance visits	75
C72 Draft or write functional procedures	75
J510 Participate in design analyses, project team meetings, or internal design review meetings	75
D142 Conduct or participate in program management meetings or working groups	75
D199 Participate in technical meetings, such as interoperability meetings on program or project reviews	67
D166 Develop functional requirements documents	67
E247 Edit input or output data	58
D208 Prepare program products, such as test plans, specifications, or manuals	58
J487 Develop or provide input to functional descriptions or data requirements documents	58

NOTE: Percent of Prefix may not add to 100 percent due to rounding

TABLE A14
 CLUSTER III/JOB C
 (ST378)

Group Size: 8	Percent of D Prefix Officers: 13
Average Time in Present Job: 27	Percent of C Prefix Officers: 26
Average Number Tasks Performed: 109	Percent of D Prefix Airmen: 13
Percent of Sample: Less than 1	Percent of W Prefix Airmen: 50

The following are in descending order by percent members performing:

<u>TASKS</u>	<u>PERCENT MEMBERS PERFORMING</u>
H352 Debug computer programs	100
A11 Research or review manuals, documentation, or technical publications to aid in problem isolation or correction	88
C79 Format magnetic media	88
C95 Load programs or data from cards, disks, or tapes	88
H383 Interpret output or products for users	88
C68 Determine corrective action for identified hardware	75
G288 Design or provide input to record access and storage methods	75
H343 Assign file or disk space to users or projects	75
G285 Design or provide input to data elements or codes programs	75
C126 Recommend selection of commercially available software	75
H393 Participate with programmers in testing or debugging	75
H372 Draft or write user operation manuals	75

NOTE: Percent of Prefix may not add to 100 percent due to rounding

TABLE A15
 CLUSTER III/JOB D
 (ST396)

Group Size: 16	Percent of D Prefix Officers: 0
Average Time in Present Job: 29	Percent of C Prefix Officers: 25
Average Number Tasks Performed: 110	Percent of D Prefix Airmen: 12
Percent of Sample: Less than 1	Percent of W Prefix Airmen: 63

The following are in descending order by percent members performing:

TASKS	PERCENT MEMBERS PERFORMING
A3 Classify problems as hardware related, software related, or user lack of knowledge related	100
C76 Enter data via console	94
C95 Load programs or data from cards, disks, or tapes	94
C54 Analyze console displays or system printouts	88
A15 Validate existence of systems problems	88
A5 Determine whether systems problems are local or Air Force wide	88
C127 Request system information via console	75
C129 Respond to system requests	75
C121 Prepare or provide input to recovery plans or procedures	75
H356 Determine causes to abnormal program halts	69
C55 Analyze or identify system or hardware failure trends	69
C85 Interpret indicating lights on peripheral equipment	69
H357 Determine data base currency or accuracy	63
H406 Review changes to data base	44

NOTE: Percent of Prefix may not add to 100 percent due to rounding

TABLE A16
 CLUSTER III/JOB E
 (ST349)

Group Size: 6	Percent of D Prefix Officers: 0
Average Time in Present Job: 65	Percent of C Prefix Officers: 0
Average Number Tasks Performed: 116	Percent of D Prefix Airmen: 0
Percent of Sample: Less than 1	Percent of W Prefix Airmen: 101

The following are in descending order by percent members performing:

<u>TASKS</u>	<u>PERCENT MEMBERS PERFORMING</u>
C83 Input or retrieve data using remote inquiry units	100
C81 Initialize processing, such as batched job, on-line, or off-line	100
H362 Develop data base retrieval procedures	83
H357 Determine data base currency or accuracy	83
H339 Analyze job streams	83
H385 Maintain file space listings or catalogs	83
C92 Isolate problems on production runs	83
H340 Analyze program dumps	67
H436 Write utility programs	67
H413 Review data base recovery procedures	67
C105 Monitor computer area environmental conditions	67
H363 Develop data base update procedures	67

NOTE: Percent of Prefix may not add to 100 percent due to rounding

TABLE A17
 CLUSTER III/JOB F
 (ST321)

Group Size: 17	Percent of D Prefix Officers: 0
Average Time in Present Job: 26	Percent of C Prefix Officers: 54
Average Number Tasks Performed: 145	Percent of D Prefix Airmen: 6
Percent of Sample: Less than 1	Percent of W Prefix Airmen: 36

The following are in descending order by percent members performing:

TASKS	PERCENT MEMBERS PERFORMING
B42 Process AF Forms 3215 (Communications-Computer Systems Requirement Document)	88
C78 Explain networking systems concepts to users	88
B20 Coordinate redistribution of equipment or facilities	82
C65 Coordinate scheduled downtime with main site, Office of Primary Responsibility (OPR), and remote users	76
B29 Evaluate quality of service provided to users	76
C60 Change systems hardware configurations	76
B33 Integrate common functional user requirements	71
C56 Analyze systems communications requirements	71
C69 Develop emergency plans for operations	71
B22 Determine interoperability requirements	71
B24 Determine redistribution of equipment or facilities	71
B44 Provide technical information for establishing baseline requirements for programs	59

NOTE: Percent of Prefix may not add to 100 percent due to rounding

TABLE A18
 CLUSTER III/JOB G
 (ST300)

Group Size: 61	Percent of D Prefix Officers: 0
Average Time in Present Job: 31	Percent of C Prefix Officers: 60
Average Number Tasks Performed: 252	Percent of D Prefix Airmen: 9
Percent of Sample: 8	Percent of W Prefix Airmen: 32

The following are in descending order by percent members performing:

<u>TASKS</u>	<u>PERCENT MEMBERS PERFORMING</u>
G276 Analyze data base requirements	90
J502 Identify computer applications software to fulfill user requirements	84
D179 Evaluate commercially available computer software or hardware	80
H409 Review computer software functional descriptions	79
J511 Participate in technical user groups	74
G329 Review data base specifications	74
D204 Prepare justifications for programs, projects, or systems	74
G275 Analyze current communications-computer systems processing capabilities	74
C77 Evaluate impact of projected requirements on operations activities	70
H393 Participate with programmers in testing or debugging programs	69
C129 Respond to system requests	64
H382 Identify data base deficiencies	62

NOTE: Percent of Prefix may not add to 100 percent due to rounding

TABLE A19
 CLUSTER III/JOB H
 (ST329)

Group Size: 6	Percent of D Prefix Officers: 34
Average Time in Present Job: 22	Percent of C Prefix Officers: 17
Average Number Tasks Performed: 153	Percent of D Prefix Airmen: 17
Percent of Sample: Less than 1	Percent of W Prefix Airmen: 33

The following are in descending order by percent members performing:

<u>TASKS</u>	<u>PERCENT MEMBERS PERFORMING</u>
G324 Prepare plans to test software interface	100
J481 Determine cause of applications system software malfunctions	100
D240 Verify contractor provided solutions to computer software or hardware problems or malfunctions	100
I467 Test computer programs	83
C91 Isolate causes of machine stops or malfunctions	83
I450 Participate in software acceptance tests on communications-computer systems	83
I440 Determine impact of operating systems errors	83
H366 Develop or provide input to software release procedures	83
C59 Certify acceptance of software packages	83
J482 Determine cause of operating system software malfunctions	83
I468 Track status of software discrepancies	67
H394 Prepare communications-computer system software test analysis reports	67

NOTE: Percent of Prefix may not add to 100 percent due to rounding

TABLE A20
SOFTWARE SUPPORT SPECIALIST
(ST045)

Group Size: 12	Percent of D Prefix Officers: 0
Average Time in Present Job: 17	Percent of C Prefix Officers: 75
Average Number Tasks Performed: 48	Percent of D Prefix Airmen: 0
Percent of Sample: Less than 1	Percent of W Prefix Airmen: 25

The following are in descending order by percent members performing:

<u>TASKS</u>	<u>PERCENT MEMBERS PERFORMING</u>
C126 Recommend selection of commercially available software packages	92
C79 Format magnetic media	67
G278 Assist functional users in defining requirements	58
G276 Analyze data base requirements	50
G277 Analyze input products of other functional systems for interface with existing systems	50
B30 Identify requirements for new technology or prototypes	50
G279 Assist systems analysts in interpreting functional requirements	42
G284 Design or provide input to data base specifications	42
B33 Integrate common functional user requirements	42
B19 Check operational status of equipment	33
G285 Design or provide input to data elements or codes	33
G286 Design or provide input to input or output formats	33

NOTE: Percent of Prefix may not add to 100 percent due to rounding

TABLE A21
PROGRAM AND PROJECT MANAGERS CLUSTER IV
(ST038)

Group Size: 194	Percent of D Prefix Officers: 3
Average Time in Present Job: 26	Percent of C Prefix Officers: 88
Average Number Tasks Performed: 90	Percent of D Prefix Airmen: 2
Percent of Sample: 26	Percent of W Prefix Airmen: 8

The following are in descending order by percent members performing:

<u>TASKS</u>	<u>PERCENT MEMBERS PERFORMING</u>
D142 Conduct or participate in program management meetings or or working groups	80
D194 Observe contractor demonstrations	69
B34 Justify funds for programs	66
D160 Determine priority of program or project requirements	63
D183 Evaluate impact on programs or projects due to delays	62
D150 Defend program or project schedules or milestones	62
D182 Evaluate functional descriptions	59
D199 Participate in technical meetings, such as interoperability meetings on program or project reviews	56
D181 Evaluate effect of funding or manpower cuts on programs or projects	55
D168 Develop inputs for SON, MEN, SOW	55
D233 Review requirement documents, such as SOW, PSP, SORD, MEN, SON, or ROC	55
D222 Review cost estimates for programs or projects	51

NOTE: Percent of Prefix may not add to 100 percent due to rounding

TABLE A22
 CLUSTER IV/JOB A
 (ST191)

Group Size: 10	Percent of D Prefix Officers: 0
Average Time in Present Job: 39	Percent of C Prefix Officers: 90
Average Number Tasks Performed: 49	Percent of D Prefix Airmen: 0
Percent of Sample: Less than 1	Percent of W Prefix Airmen: 10

The following are in descending order by percent members performing:

TASKS	PERCENT MEMBERS PERFORMING
D182 Evaluate functional descriptions	100
G332 Review program specifications	90
D229 Review or evaluate program products, such as test plans, specifications, or manuals	80
D199 Participate in technical meetings, such as interoperability meetings on program or project reviews	80
D228 Review Interface Control Documents	80
D206 Prepare or update Interface Control Documents (ICD)	60
G278 Assist functional users in defining requirements	60
G333 Review programming standards	50
J487 Develop or provide input to functional descriptions or data requirements documents	40
J492 Develop or provide input to system specifications	40
J511 Participate in technical user groups	40
D203 Prepare design change requests	30

NOTE: Percent of Prefix may not add to 100 percent due to rounding

TABLE A23

CLUSTER IV/JOB B
(ST260)

Group Size: 6	Percent of D Prefix Officers: 0
Average Time in Present Job: 20	Percent of C Prefix Officers: 68
Average Number Tasks Performed: 59	Percent of D Prefix Airmen: 0
Percent of Sample: Less than 1	Percent of W Prefix Airmen: 34

The following are in descending order by percent members performing:

<u>TASKS</u>	<u>PERCENT MEMBERS PERFORMING</u>
D142 Conduct or participate in program management meetings or working groups	100
D213 Report status of program manager milestones	83
D150 Defend program or project schedules or milestones	83
D160 Determine priority of program or project requirements	67
D167 Develop input to program or project directives	67
D172 Develop program or project delivery schedules	67
D217 Resolve program or project milestone conflicts	67
J519 Review lifecycle documentation	67
D183 Evaluate impact on programs or projects due to delays	50
G279 Assist systems analysts in interpreting functional requirements	50
G331 Review data systems project plans	50
G330 Review data systems project directives	50

NOTE: Percent of Prefix may not add to 100 percent due to rounding

TABLE A24
 CLUSTER IV/JOB C
 (ST231)

Group Size: 9	Percent of D Prefix Officers: 0
Average Time in Present Job: 25	Percent of C Prefix Officers: 99
Average Number Tasks Performed: 69	Percent of D Prefix Airmen: 0
Percent of Sample: Less than 1	Percent of W Prefix Airmen: 0

The following are in descending order by percent members performing:

TASKS	PERCENT MEMBERS PERFORMING
D142 Conduct or participate in program management meetings or working groups	100
A9 Refer systems problems to responsible agencies or persons	100
A12 Solicit possible systems problems from users	89
B29 Evaluate quality of service provided to users	78
G280 Brief functional area personnel on capabilities of proposed communications-computer systems equipment	67
G278 Assist functional users in defining requirements	67
G303 Develop or provide input to conversion plans	67
B30 Identify requirements for new technology or prototypes	67
H410 Review configuration management plans	56
D236 Review transition plans	56
D137 Approve or disapprove configuration management plans	56
D169 Develop inputs to installation or cut-over plans	33

NOTE: Percent of Prefix may not add to 100 percent due to rounding

TABLE A25
 CLUSTER IV/JOB D
 (ST241)

Group Size: 9	Percent of D Prefix Officers: 0
Average Time in Present Job: 17	Percent of C Prefix Officers: 88
Average Number Tasks Performed: 101	Percent of D Prefix Airmen: 0
Percent of Sample: Less than 1	Percent of W Prefix Airmen: 11

The following are in descending order by percent members performing:

<u>TASKS</u>	<u>PERCENT MEMBERS PERFORMING</u>
D236 Review transition plans	89
G333 Review programming standards	78
H410 Review configuration management plans	78
D196 Participate in Configuration Control Boards (CCB)	67
C59 Certify acceptance of software packages	67
D225 Review inputs to programming documents	67
C126 Recommend selection of commercially available software	67
H409 Review computer software functional descriptions	67
G304 Develop or provide input to software development plans	56
H377 Evaluate inputs to programming standards	56
D151 Define computer software configuration items	56
D179 Evaluate commercially available computer software or hardware	44

NOTE: Percent of Prefix may not add to 100 percent due to rounding

TABLE A26
 CLUSTER IV/JOB E
 (ST354)

Group Size: 7	Percent of D Prefix Officers: 0
Average Time in Present Job: 26	Percent of C Prefix Officers: 85
Average Number Tasks Performed: 74	Percent of D Prefix Airmen: 14
Percent of Sample: Less than 1	Percent of W Prefix Airmen: 0

The following are in descending order by percent members performing:

<u>TASKS</u>	<u>PERCENT MEMBERS PERFORMING</u>
D155 Determine funding sources for programs or projects	100
D154 Determine financial or manpower cost estimates or savings for programs or projects	86
D187 Evaluate requirements funding	86
D181 Evaluate effect of funding or manpower cuts on programs	86
B20 Coordinate redistribution of equipment or facilities	86
B34 Justify funds for programs	71
D169 Develop inputs to installation or cut-over plans	71
D175 Draft or write justifications for program or project cost over-runs	71
D162 Determine required reliability, maintainability, or availability of systems	71
D188 Identify future installation requirements	71
B24 Determine redistribution of equipment or facilities	71
D214 Request additional funding or manpower for programs or projects	71

NOTE: Percent of Prefix may not add to 100 percent due to rounding

TABLE A27
 CLUSTER IV/JOB F
 (ST302)

Group Size: 13	Percent of D Prefix Officers: 0
Average Time in Present Job: 24	Percent of C Prefix Officers: 100
Average Number Tasks Performed: 70	Percent of D Prefix Airmen: 0
Percent of Sample: Less than 1	Percent of W Prefix Airmen: 0

The following are in descending order by percent members performing:

<u>TASKS</u>	<u>PERCENT MEMBERS PERFORMING</u>
D168 Develop inputs for SON, MEN, or SOW	100
D146 Consolidate inputs to SON, MEN, CSRD, or ROC	100
B30 Identify requirements for new technology or prototypes	85
D167 Develop input to program or project directives	77
D204 Prepare justifications for programs, projects, or systems	77
D171 Develop inputs to programming documents	69
D233 Review requirement documents, such as SOW, PSP, SORD, MEN, SON, or ROC	69
D177 Establish or provide input to Initial Operational Capabilities (IOC) or Full Operational Capabilities (FOC)	69
D193 Monitor status of POM inputs	69
D239 Validate requirements for programs, projects, or systems	54
D198 Participate in planning or programming review boards or program review committees	54
B27 Draft or write Statements of Work (SOW)	54

NOTE: Percent of Prefix may not add to 100 percent due to rounding

TABLE A28
 CLUSTER IV/JOB G
 (ST306)

Group Size: 47	Percent of D Prefix Officers: 0
Average Time in Present Job: 28	Percent of C Prefix Officers: 91
Average Number Tasks Performed: 151	Percent of D Prefix Airmen: 0
Percent of Sample: Less than 1	Percent of W Prefix Airmen: 6

The following are in descending order by percent members performing:

<u>TASKS</u>	<u>PERCENT MEMBERS PERFORMING</u>
D142 Conduct or participate in program management meetings or working groups	89
D194 Observe contractor demonstrations	89
D160 Determine priority of program or project requirements	85
D148 Coordinate requirements with agencies or contractors for systems, facilities, or equipment	78
D150 Defend program or project schedules or milestones	78
D161 Determine priority of system, subsystem, facility, or equipment requirements	78
D139 Brief at program management reviews	78
D217 Resolve program or project milestone conflicts	78
D204 Prepare justifications for programs, projects, or systems	77
D149 Coordinate with supporting activities on their ability to support systems, subsystems, facilities, or equipment	77
D166 Develop functional requirements documents	74
C77 Evaluate impact of projected requirements on operations activities	72

NOTE: Percent of Prefix may not add to 100 percent due to rounding

TABLE A29

CLUSTER IV/JOB H
(ST351)

Group Size: 1	Percent of D Prefix Officers: 0
Average Time in Present Job: 38	Percent of C Prefix Officers: 96
Average Number Tasks Performed: 128	Percent of D Prefix Airmen: 0
Percent of Sample: Less than 1	Percent of W Prefix Airmen: 6

The following are in descending order by percent members performing:

TASKS	PERCENT MEMBERS PERFORMING
L573 Coordinate with contracting officers on contracting specifications	100
L583 Draft or write inputs to RFP items, such as CDRL, DID, CLIN, or PWS	85
L575 Coordinate with legal personnel or contracting officers on technical aspects of contracts, bids, or proposals	78
L606 Participate on source selection boards, such as Source Selection Evaluation Boards (SSEB) or SSAC	75
L585 Evaluate contractor compliance with contract terms	74
L571 Coordinate modifications to contracts with affected personnel	72
L614 Prepare or provide inputs to requirements contracts	71
L579 Develop Request for Proposal (RFP)	66
M647 Evaluate bids, quotations, or proposals for contract awards	65
L574 Coordinate with customer on receipt or nonreceipt of contract deliverables	63
L620 Respond to contractor inquiries on contracting matters	62
L570 Consolidate RFP item inputs, such as CDRL, DID, CLIN, or PWS inputs	62

NOTE: Percent of Prefix may not add to 100 percent due to rounding

TABLE A30
MISSION SUPPORT CLUSTER V
(ST031)

Group Size: 28	Percent of D Prefix Officers: 0
Average Time in Present Job: 20	Percent of C Prefix Officers: 4
Average Number Tasks Performed: 49	Percent of D Prefix Airmen: 4
Percent of Sample: Less than 1	Percent of W Prefix Airmen: 92

The following are in descending order by percent members performing:

<u>TASKS</u>	<u>PERCENT MEMBERS PERFORMING</u>
M655 Maintain equipment custodian accounts	61
C66 Copy disk packs, diskettes, or tapes	57
M651 Inventory equipment, tools, or supplies	57
M660 Place supplies or equipment in storage	54
B19 Check operational status of equipment	54
B42 Prepare unclassified media for mail, delivery, or distribution	54
M650 Inspect supplies or equipment	50
M644 Establish or maintain files of hand receipts	50
C120 Power up or power down communications-computer systems equipment	50
B20 Coordinate redistribution of equipment or facilities	50
M666 Prepare supply documents, such as requisitions, invoices, or vouchers	46
M632 Cancel supply requisitions	39
M658 Pack or unpack tools, supplies, or equipment	39

NOTE: Percent of Prefix may not add to 100 percent due to rounding

TABLE A31
 CLUSTER V/JOB A
 (ST138)

Group Size: 13	Percent of D Prefix Officers: 0
Average Time in Present Job: 14	Percent of C Prefix Officers: 0
Average Number Tasks Performed: 74	Percent of D Prefix Airmen: 0
Percent of Sample: Less than 1	Percent of W Prefix Airmen: 95

The following are in descending order by percent members performing:

<u>TASKS</u>	<u>PERCENT MEMBERS PERFORMING</u>
M668 Receipt for supplies or equipment	92
A11 Research or review manuals, documentation, or technical publications to aid in problem isolation or correction	85
B19 Check operational status of equipment	69
B20 Coordinate redistribution of equipment or facilities	69
C95 Load programs or data from cards, disks, or tapes	69
M666 Prepare supply documents, such as requisitions, invoices, or vouchers	69
M663 Prepare procurement documents, such as purchase requests	62
C120 Power up or power down communications-computer systems equipment	62
M671 Research status of purchase orders	54
M678 Track equipment delivery progress	54
M651 Inventory equipment, tools, or supplies	54
M648 Evaluate use of supplies	46

NOTE: Percent of Prefix may not add to 100 percent due to rounding

TABLE A32
 CLUSTER V/JOB B
 (ST092)

Group Size: 11	Percent of D Prefix Officers: 0
Average Time in Present Job: 25	Percent of C Prefix Officers: 9
Average Number Tasks Performed: 27	Percent of D Prefix Airmen: 9
Percent of Sample: Less than 1	Percent of W Prefix Airmen: 81

The following are in descending order by percent members performing:

<u>TASKS</u>	<u>PERCENT MEMBERS PERFORMING</u>
M668 Receipt for supplies or equipment	91
M650 Inspect supplies or equipment	82
M652 Issue tools, equipment, or supplies	73
M655 Maintain equipment custodian accounts	64
M659 Pick up parts, tools, or supplies	55
M651 Inventory equipment, tools, or supplies	55
M643 Dispose of excess or unserviceable tools, supplies, or equipment	55
M660 Place supplies or equipment in storage	55
M644 Establish or maintain files of hand receipts	55
M632 Cancel supply requisitions	55
M653 Load or unload tools, supplies, or equipment	45
M658 Pack or unpack tools, supplies, or equipment	45
M645 Establish or update inventory or stock control records	45

NOTE: Percent of Prefix may not add to 100 percent due to rounding

TABLE A33
SYSTEM SECURITY MANAGERS
(ST042)

Group Size: 37	Percent of D Prefix Officers: 3
Average Time in Present Job: 22	Percent of C Prefix Officers: 65
Average Number Tasks Performed: 52	Percent of D Prefix Airmen: 0
Percent of Sample: Less than 1	Percent of W Prefix Airmen: 33

The following are in descending order by percent members performing:

<u>TASKS</u>	<u>PERCENT MEMBERS PERFORMING</u>
K522 Brief or debrief personnel on security procedures	86
K520 Administer security programs	81
K526 Conduct security inspections	81
K552 Mark, downgrade, or page check classified documents	73
K550 Issue or change combinations	70
K524 Conduct or participate in security managers meetings	65
K546 Implement security OI	62
K529 Coordinate emergency plans for protection, removal, or destruction of classified materials with security managers	62
K553 Monitor access to secure, controlled, or restricted areas	59
K525 Conduct security debriefs for users	59
K521 Advise commander on possible security compromise procedures	57
K531 Coordinate with base security manager on security matters	57

NOTE: Percent of Prefix may not add to 100 percent due to rounding