

AD-A236 636

R-932

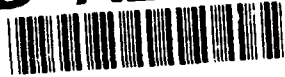

April 1991

# INCEL

By Peter J. Hearst, Ph. D.

## Technical Report

Sponsored By Naval Facilities  
Engineering Command

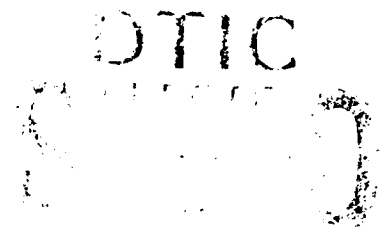

# SLIPMETER FOR FLOOR COATINGS

**ABSTRACT** Floor coating surfaces can be hazardously slippery. Problems in slip resistance measurement and commercially available slipmeters are discussed. None of these slipmeters are suitable for field measurements by untrained personnel of the rough surfaces produced by adding grit to the coating systems. A new slipmeter, with a moving sled, is proposed for measuring the dynamic slip resistance of these textured coatings.

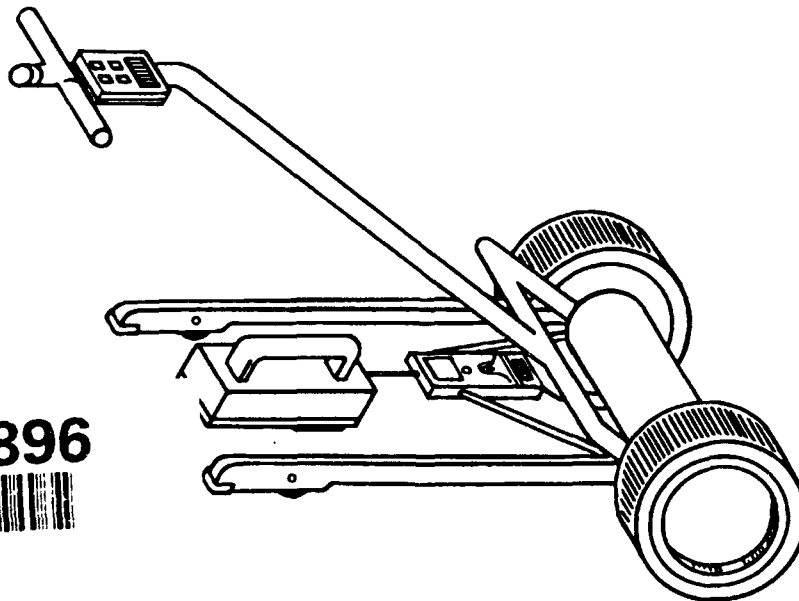

91-01896



NAVAL CIVIL ENGINEERING LABORATORY PORT HUENEME CALIFORNIA 93043-5003

METRIC CONVERSION FACTORS

Approximate Conversions to Metric Measures

Symbol	When You Know	Multiply by	To Find	Symbol
		<b>LENGTH</b>		
in	inches	* 2.5	centimeters	cm
ft	feet	30	centimeters	cm
yd	yards	0.9	meters	m
mi	miles	1.6	kilometers	km
		<b>AREA</b>		
in <sup>2</sup>	square inches	6.5	square centimeters	cm <sup>2</sup>
ft <sup>2</sup>	square feet	0.09	square meters	m <sup>2</sup>
yd <sup>2</sup>	square yards	0.8	square meters	m <sup>2</sup>
mi <sup>2</sup>	square miles	2.6	square kilometers	km <sup>2</sup>
	acres	0.4	hectares	ha
		<b>MASS (weight)</b>		
oz	ounces	28	grams	g
lb	pounds	0.45	kilograms	kg
	short tons	0.9	tonnes	t
	(2,000 lb)			
		<b>VOLUME</b>		
tsp	teaspoons	5	milliliters	ml
Tbsp	tablespoons	15	milliliters	ml
fl oz	fluid ounces	30	milliliters	ml
c	cups	0.24	liters	l
pt	pints	0.47	liters	l
qt	quarts	0.95	liters	l
gal	gallons	3.8	liters	l
ft <sup>3</sup>	cubic feet	0.03	cubic meters	m <sup>3</sup>
yd <sup>3</sup>	cubic yards	0.76	cubic meters	m <sup>3</sup>
		<b>TEMPERATURE (exact)</b>		
°F	Fahrenheit temperature	5/9 (after subtracting 32)	Celsius temperature	°C

Approximate Conversions from Metric Measures

When You Know	Multiply by	To Find	Symbol
	<b>LENGTH</b>		
millimeters	0.04	inches	in
centimeters	0.4	inches	in
meters	3.3	feet	ft
meters	1.1	yards	yd
kilometers	0.6	miles	mi
	<b>AREA</b>		
square centimeters	0.16	square inches	in <sup>2</sup>
square meters	1.2	square yards	yd <sup>2</sup>
square kilometers	0.4	square miles	mi <sup>2</sup>
hectares (10,000 m <sup>2</sup> )	2.5	acres	
	<b>MASS (weight)</b>		
grams	0.035	ounces	oz
kilograms	2.2	pounds	lb
tonnes (1,000 kg)	1.1	short tons	
	<b>VOLUME</b>		
milliliters	0.03	fluid ounces	fl oz
liters	2.1	pints	pt
liters	1.06	quarts	qt
liters	0.26	gallons	gal
cubic meters	35	cubic feet	ft <sup>3</sup>
cubic meters	1.3	cubic yards	yd <sup>3</sup>
	<b>TEMPERATURE (exact)</b>		
Celsius temperature	9/5 (then add 32)	Fahrenheit temperature	°F

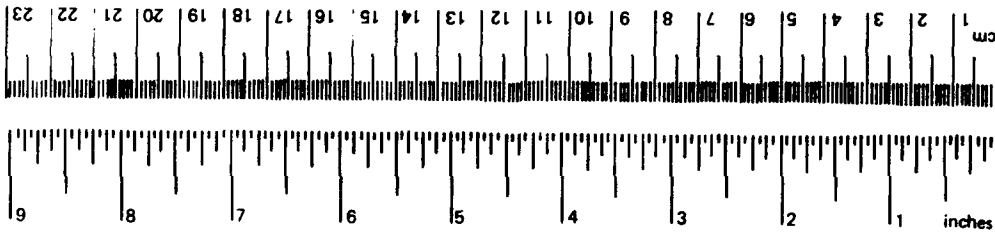

\*1 in. = 2.54 (exact). For other exact conversions and more detailed tables, see NBS Misc. Publ. 286, Units of Weights and Measures, Price \$2.25, SD Catalog No. C13.10:286.

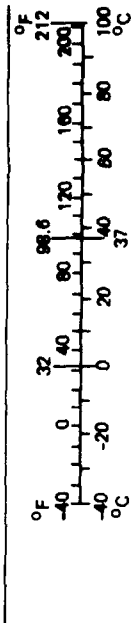

# REPORT DOCUMENTATION PAGE

Form Approved  
OMB No. 0704-018

Public reporting burden for this collection of information is estimated to average 1 hour per response, including the time for reviewing instructions, searching existing data sources, gathering and maintaining the data needed, and completing and reviewing the collection of information. Send comments regarding this burden estimate or any other aspect of this collection information, including suggestions for reducing this burden, to Washington Headquarters Services, Directorate for Information and Reports, 1215 Jefferson Davis Highway, Suite 1204, Arlington, VA 22202-4302, and to the Office of Management and Budget, Paperwork Reduction Project (0704-0188), Washington, DC 20503.

1. AGENCY USE ONLY (Leave blank)		2. REPORT DATE April 1991	3. REPORT TYPE AND DATES COVERED Final; Oct 82 - Mar 89	
4. TITLE AND SUBTITLE <b>SLIPMETER FOR FLOOR COATINGS</b>			5. FUNDING NUMBERS PR - Y1316-01-99-020 WU - DN668003	
6. AUTHOR(S) Peter J. Hearst, Ph. D.				
7. PERFORMING ORGANIZATION NAME(S) AND ADDRESS(ES) Naval Civil Engineering Laboratory Port Hueneme, CA 93043-5003			8. PERFORMING ORGANIZATION REPORT NUMBER <b>TR - 932</b>	
9. SPONSORING/MONITORING AGENCY NAME(S) AND ADDRESS(ES) Naval Facilities Engineering Command Alexandria, VA 22332			10. SPONSORING/MONITORING AGENCY REPORT NUMBER	
11. SUPPLEMENTARY NOTES				
12a. DISTRIBUTION/AVAILABILITY STATEMENT Approved for public release; distribution is unlimited.			12b. DISTRIBUTION CODE <b>A-1</b>	
13. ABSTRACT (Maximum 200 words)  Floor coating surfaces can be hazardously slippery. Problems in slip resistance measurement and commercially available slipmeters are discussed. None of these slipmeters are suitable for field measurements by untrained personnel of the rough surfaces produced by adding grit to the coating systems. A new slipmeter, with a moving sled, is proposed for measuring the dynamic slip resistance of these textured coatings.				
14. SUBJECT TERMS Textured floor coatings, Horizontal Pull Slipmeter, slip resistance, British Pendulum Tester, NCEL Slipmeter, drag type slipmeter			15. NUMBER OF PAGES 31	
			16. PRICE CODE	
17. SECURITY CLASSIFICATION OF REPORT Unclassified	18. SECURITY CLASSIFICATION OF THIS PAGE Unclassified	19. SECURITY CLASSIFICATION OF ABSTRACT Unclassified	20. LIMITATION OF ABSTRACT UL	

---

## CONTENTS

	<b>Page</b>
INTRODUCTION .....	1
BACKGROUND .....	1
Slip Resistance Concepts .....	1
Slip Resistance in Hangars .....	2
AVAILABLE SLIPMETERS .....	2
Commercial Slipmeters .....	2
NCEL Slipmeter .....	4
LABORATORY AND FIELD EXPERIMENTS .....	4
DISCUSSION OF RESULTS .....	5
Instrument Comparisons .....	5
NCEL Slipmeter Operation .....	8
SLIPMETER FOR FIELD USE .....	9
CONCLUSIONS .....	9
RECOMMENDATIONS .....	10
REFERENCES .....	10

### List of Tables

Table 1. Slip Resistance Comparisons for Test Panels .....	11
Table 2. Effect of Loading and Configuration .....	12
Table 3. Effect of Configuration of Triple Feet .....	13
Table 4. Slip Resistance Measurements on Hangar Floors .....	14
Table 5. Selected Slip Resistances of Oily Coating Systems .....	15

---

---

**CONTENTS (continued)**

**Page**

**List of Figures**

Figure 1. Horizontal Pull Slipmeter .....	16
Figure 2. British Pendulum Tester .....	16
Figure 3. Heavy sled of NCEL Slipmeter .....	17
Figure 4. Light sled of NCEL Slipmeter .....	17
Figure 5. Light sled with instrumentation .....	18
Figure 6. Front view of cart for NCEL Slipmeter .....	18
Figure 7. Rear view of cart for NCEL Slipmeter .....	19
Figure 8. Sample NCEL Slipmeter recorder traces .....	20
Figure 9. Slip resistance of coating systems with alumina and with polypropylene .....	21
Figure 10. Effect of short and long feet on the measured slip resistance of coating systems with alumina .....	22
Figure 11. Slip resistances of hangar floors using the NCEL Slipmeter at 1250 cm per min and the British Pendulum Tester .....	23
Figure 12. Slip resistances of hangar floors using the NCEL Slipmeter at 5000 cm per min and the British Pendulum Tester .....	24
Figure 13. Conceptual slipmeter for field use .....	25
Figure 14. Sled for conceptual slipmeter .....	25

---

## INTRODUCTION

The Navy has continuing problems with slippery reflective coating systems on aircraft maintenance hangar floors. Such floors not only are safety hazards for personnel but also may cause collisions between moving equipment and stationary aircraft. A slipmeter is needed that is suitable for field measurement of the slip resistance of such a coating system to determine whether it has been properly applied and whether it continues to be safe for use.

The objective of the work on reflective floor coatings at the Naval Civil Engineering Laboratory (NCEL) was to assure the application of reflective coating systems with good performance. The objective of NCEL research on slip resistance measurement was the adoption, adaptation, or development of a slipmeter that is useful in determining the safety of coated hangar floors. Such a slipmeter could adequately measure the slip resistance of a coating system with a rough surface and could be used by field personnel without extensive technical skill.

NCEL became interested in the measurement of slip resistance of rough coating surfaces while performing research on marking coatings that would have minimal effect on the slip resistance of the decks of aircraft carriers. Because no adequate method was available for measuring the slip resistance of such decks, the initial model of the NCEL Slipmeter was designed and constructed. The slipmeter was improved and modified for use on hangar floors under the sponsorship of the Naval Facilities Engineering Command.

This report discusses available methods for slip resistance measurement, describes the development of the NCEL Slipmeter, and presents the conceptual design of a slipmeter that should meet Navy needs for a field instrument suitable for use on rough coated surfaces.

## BACKGROUND

### Slip Resistance Concepts

Slip resistance is often expressed as the coefficient of friction, which is the ratio of the force required to overcome the friction between two surfaces to the force holding the surfaces together. (The latter force, which is normal to the surfaces, often is equal to the weight of a metal block or a sled.) The force required to start the motion between the two surfaces is used to calculate the static coefficient of friction. The force required to continue the motion is used to calculate the dynamic coefficient of friction or kinetic coefficient of friction.

From the time of Leonardo da Vinci, it had been believed that the frictional force was (1) proportional to the load and (2) independent of the contact area. A third law, from the 18th century, states that the friction is independent of the sliding velocity. According to these laws, neither the load nor the contact area nor the velocity should affect the coefficient of friction. According to more modern understanding, the first two laws are accurate to about 10%, but a change in velocity can produce an effect of about 50%. At very low speeds, the friction increases rapidly with increasing speed until a maximum is reached. As the speed is increased further, the friction drops off again and may then reach a relatively steady value (Ref 1).

The adhesion between two surfaces in contact increases with time and therefore the static coefficient is affected by the contact time before the friction measurements are started. The measurement of a true static coefficient of friction is also made more difficult by the creep that can take place before the slipping between the surfaces occurs. An excellent analysis of problems in slip resistance measurement and of the many

---

methods that have been used has been published (Ref 2).

The above discussions deal with the frictional properties of two surfaces in close contact. The measurement of slip resistance becomes more complicated when water or oil is introduced between these surfaces. The measurement is complicated further when one of the surfaces is rough, and still further when the rough surface contains grit with sharp corners that dig into the opposing smooth surface. In such situations, the moving surface may move in directions different from that of the pull, may chatter, or may skip over the other surface, and the measured friction values may be reduced.

### **Slip Resistance in Hangars**

There is little problem with the slip resistance of hangar floors when both the floors and the safety shoes that are used are clean and dry. The slipperiness problems occur when the floors are wet or oily. Water alone does not present a problem, as judged from NCEL slip resistance measurements of clean hangar floor areas. The hazardous slip resistance of wet hangar floors is caused by the residual oils or detergents that remain on the floors after typical cleaning. The floors are also slippery when covered with aqueous detergent solution during the washing of aircraft.

A slipmeter that is used for coated hangar floors should be able to measure the slip resistances of various coating systems that are likely to be used. To determine the safety of hangar floors, it is desirable to measure the slip resistance when they are oily or wet with detergent solution. Because personnel working in the hangars typically wear Navy safety shoes, the carboxylated nitrile rubber used for the soles of these shoes is appropriate for the other test surface in the slip resistance measurements.

Both the static coefficient of friction and the dynamic coefficient of friction can be used to characterize the slip resistance. The former is considered to be a better indication of whether a

person or vehicle would start to slip; the latter is considered to be a better indication of whether a person or vehicle, once slipping, will be stopped by friction. Studies of the articulation of the leg during normal walking have indicated that the heel is dropped vertically on the floor and it has been argued that, in the absence of any horizontal force component at first contact, the static coefficient of friction is more important. However, many slipping accidents on hangar floors occur when personnel step off ladders and touch the floor with lateral motion, or when they otherwise step laterally. The dynamic coefficient of friction is then more important. Furthermore, after the initiation of a slip by a person or a vehicle, dynamic slip resistance is required to stop the slip. For these reasons, the emphasis in NCEL measurements was on dynamic slip resistance.

## **AVAILABLE SLIPMETERS**

### **Commercial Slipmeters**

Many procedures and devices for measuring slip resistance are described in the methods of the American Society for Testing and Materials (ASTM) and in government specifications. Most of these are laboratory methods, many are for specific types of materials, and few are suitable for textured or rough surfaces. The measurement of slip resistance has been the subject of an ASTM symposium (Ref 3), but this did not include a discussion of rough surfaces.

A drag-type meter is most often used for slip resistance measurement. Such a device generally uses a metal sled or block with rubber or other facing that is pulled across the material to measure its slip resistance. (The slip resistance is, of course, dependent on the nature of the surfaces of the test material and of the facing of the sled.)

A widely used portable drag type slipmeter is the Horizontal Pull Slipmeter (Figure 1). This instrument is also called the Liberty Mutual Slipmeter and is used in ASTM Method F 609. It is essentially a weight with three half-inch-diameter

---

leather or rubber feet and with an attached force gauge. It is intended for measuring the slip resistance of dry smooth floors. Its gauge indicates a slip index which is equivalent to 10 times the measured static coefficient of friction.

The Olson Slipmeter, which is similar to the Horizontal Pull Slipmeter but with 3/4-inch-diameter feet, had been specified for measurement of the slip resistance of aircraft carrier decks. But when this slipmeter is used on rough surfaces, such as coarse sandpaper or nonslip decking, there is not the high reading for static friction followed by a lower reading for dynamic friction that is typical in coefficient of friction measurements. The instrument rests on ridges of the rough deck and it tends to adjust its position at a lower pulling force before actually moving at a higher force. Because of the uneven contacts, the instrument may move in a direction that deviates considerably from the direction of pull. Thus, the highest reading appears to be a dynamic reading rather than a static slip index. For measuring the slip resistance of carrier decks, the Olson Slipmeter was replaced by a simple block sled, measuring 4 by 5 inches by 1 inch high and weighing 6 pounds, that is slowly pulled across the surface with a force gauge.

A pendulum type meter can be used to measure the dynamic slip resistance. The friction between the test surface being measured and a spring-loaded platen with rubber facing at the bottom of the pendulum causes a reduction of the kinetic energy of the pendulum. The resultant reduction in the swing path of the pendulum is a measure of the slip resistance. One such instrument is the British Pendulum Tester (Figure 2), which is also called the British Portable Skid-Resistance Tester. It provides a British Pendulum Number that is approximately 100 times the dynamic coefficient of friction. It is primarily used to measure the frictional properties of roadway surfaces and is described in ASTM Method E 303. The British Pendulum Tester has been described as a consistent research instrument that is not good for routine field tests (Ref 4). Slow motion photography has shown its foot to chatter and skip on rough

surfaces (Ref 4). This effect could be accentuated by large grit in a coating or by a broomed concrete surface.

An articulated strut type meter applies the vertical and horizontal forces at the same time in the measurement of the static coefficient of friction. It thus avoids the delay in applying the horizontal force that would increase the cohesion between the surfaces and would increase the measured value of the static coefficient of friction. A laboratory instrument, the James Machine, and a portable instrument for bathing facilities, the NBS-Brungraber Tester, are described in ASTM Methods D 2047 and F 462, respectively. The portable instrument is quite complicated for Navy field use, is not intended for surfaces as rough as the hangar floors, and measures only the static coefficient of friction.

There are other, more complicated devices that are used to measure friction properties. The Mu-Meter is extensively used on runways to measure side force friction. This device is described in ASTM Method E 670. It is a trailer with two wheels, each angled outward 7.5 degrees from the center line and each loaded to 170 pounds, that are connected by a force cell. The force created between the wheels while the trailer is towed on the runway at 40 miles per hour is recorded and expressed as a Mu Number, with 100 being equivalent to a 500-lb force. Water is dispensed in front of the tires to provide side force friction measurements of wet surfaces. The Mu-Meter cannot be used for small samples or in confined areas and would be difficult to use on oily surfaces. The values obtained cannot be converted to coefficients of friction.

The British Pendulum Tester is the best commercially available, portable instrument that can measure slip resistances of rough surfaces. However, it measures the slip resistance of an area of about 3 by 5 inches, and many such areas of widely differing slip resistance can be found on a typical floor. It requires a trained technician for calibration and proper operation, and therefore it is unsuitable for general field use.

---

## NCEL Slipmeter

The NCEL Slipmeter was developed to overcome some of the disadvantages of the British Pendulum Tester. It measures the average dynamic coefficient of friction of a larger area, of the same width but about 4 to 6 feet long. It pulls a sled on rubber runners and records the required force as a coefficient of friction. It has the potential of requiring less technical skill for operation as a field instrument.

The sled of the NCEL Slipmeter can weigh 10 kg and can have full length double runners, as shown in Figure 3, or it can weigh 10 lb (4.5 kg) and can have triple runners, as shown in Figure 4. The front edges of the rubber runners are beveled at a 2:1 ratio. The runners are mounted on removable plates, which allow easy replacement or the use of varying configurations or materials. The preferred weight is 10 pounds and the preferred footing has three short runners, each with a 1-cm-square contact area, or three longer runners, each with a 1-cm by 3.3-cm contact area. One of the triple runners is mounted in the center at the rear and two runners are mounted at the sides, sufficiently back from the front to evenly distribute the weight.

The sled of the NCEL Slipmeter is pulled by a digital force gage attached to a cart. The output of the force gage is plotted as the coefficient of friction on a strip chart recorder, as illustrated in Figure 5. The cart can be moved at variable speeds of up to an excess of 5000 cm per min (about 2 mph) for dynamic slip resistance measurements. It is illustrated in Figures 6 and 7. By attaching the sled with a spring and moving the cart very slowly, the force can be increased gradually until the sled moves, and the static coefficient of friction can be measured. The cart is powered by 110 volt AC electricity. For field use, it is guided by a handle with a stop button that activates a dynamic electrical brake. For use in the laboratory it is guided by a track and has safeguards that insure appropriate stopping.

## LABORATORY AND FIELD EXPERIMENTS

Experiments were performed with the Horizontal Pull Slipmeter, with the British Pendulum Tester, and with the NCEL Slipmeter. NCEL investigated the effects of coating system designs on the slip resistance and other performance properties of reflective chemically resistant urethane (CRU) floor coating systems. The test panels prepared for that investigation were also used for the slipmeter investigation.

The test panels were prepared primarily with thin-film CRU coating systems of about 8-mil dry film thickness. They contained alumina grit or polypropylene grit of various sizes and in various quantities. The systems with alumina grit were prepared primarily with 30-mesh, 45-mesh, and 60-mesh alumina. (The openings of the screens through which these sizes passed and of the screens on which they were held were approximately 28 mils and 23 mils, 17 mils and 14 mils, and 12 mils and 10 mils, respectively.) The coats onto which the grit was broadcast or into which the grit was premixed were applied over a primer and were covered with various numbers of 2-mil CRU topcoats. The coating systems were applied to 6-by-12-inch steel test panels, about 1/16 inch thick. Most of the panels were prepared at NCEL, some were prepared by coating manufacturers.

For slip resistance measurements with the British Pendulum Tester in the laboratory, a single panel was used. This panel was clamped in a holder that held it flat and positioned it under the path of the pendulum. The rubber on the spring-loaded platen of the pendulum was made of carboxylated nitrile rubber. Separate platens were used for the wet and the oily measurements. The slip resistance was determined for the panel wetted with water or wetted with hydraulic fluid (MIL-H-83282) in accordance with ASTM E 303. A guard was attached to prevent the splashing of water or hydraulic fluid.

For static slip resistance measurements with the NCEL Slipmeter in the laboratory, one panel

was used, but for dynamic measurements six panels were used. The latter were placed end-to-end in a holder that held them flat, and were preceded and followed by smooth panels. The holder was positioned between the tracks that guided the variable speed cart. The panels were wetted with water or with hydraulic fluid before each measurement. The runners of the sled were also made of carboxylated nitrile rubber. Separate sets of runners, attached to interchangeable steel plates, were used for the wet and the oily measurements.

For dynamic slip resistance measurements, the cart was adjusted to travel at speeds of 1250, 2500, and 5000 cm per min (about 1/2, 1, and 2 mph, respectively). The recorder charts were run at 4, 8, and 16 cm per min, respectively, so that each measurement covered the same chart distance of about 15 mm.

The trace for each measurement was averaged visually and the averages for at least two measurements were again averaged for each recorded value. The averages of duplicate measurements were usually within 0.02 unit of each other, and additional measurements were made if the deviation was greater. The visual averaging was facilitated by placing an RC circuit at the recorder input to dampen the response. This circuit had a 120 K-ohm resistor in series and a 1 MFD capacitor in parallel with the input. A sample of a recorder trace with an offset dampened trace superimposed, and replicate traces obtained at four times the standard chart speed, are shown in Figure 8.

Initial experiments with the NCEL Slipmeter were performed using a 10-kg sled having two runners 2 cm wide and 12.5 cm long. At that time, the digital force gage was not available, and the sled was attached to a strain-gauged connector that acted as a force transducer and with additional instrumentation allowed the plotting of the coefficient of friction. Results with coating systems applied to test panels are shown, and compared with results obtained with the British Pendulum Tester, in Table 1.

The effect of changing the weight of the sled and the configuration of the runners was investigated for oily surfaces. The 10-kg sled had been designed so that it could be converted to a 10-lb sled by removal of two lead plates. The double runners on removable plates, with a total area of 50 sq cm, were easily replaced with triple runners, each 1 cm wide and 3.3 cm long with a total area of 10 sq cm. Measurements obtained with these combinations are shown in Table 2.

Further changes in configuration were made by reducing the area and length of the triple runners. The total area was reduced from 10 sq cm to 3 sq cm by shortening the runners to a 1-cm-square surface and, while maintaining this same area, the lengths were also reduced to 5 mm and 4 mm, with respective widths of 20 mm and 25 mm. Measurements obtained with these triple runners totaling 3 sq cm and 10 sq cm are shown in Table 3. Later laboratory and field measurements with the NCEL Slipmeter were made with the 10-lb sled using both the 10-mm-long and the 33-mm-long triple runners.

Slip resistance measurements on coated hangar floors were made with the British Pendulum Tester and with the NCEL Slipmeter at various Naval Air Stations, including NAS Atlanta, Brunswick, Miramar, Norfolk, and North Island. Slip resistances were determined for various coating system designs applied in a field test at NAS Brunswick (Ref 5). The values obtained are shown in Table 4.

## DISCUSSION OF RESULTS

### Instrument Comparisons

The slip resistance measurements in the current investigation were made primarily with the NCEL Slipmeter and with the British Pendulum Tester. Some experiments were also made with the Horizontal Pull Slipmeter. When the variable speed cart was used to pull the Horizontal Pull

---

Slipmeter for dynamic measurements, its feet hung up on the rough test panels and its gauge needle vibrated greatly. These experiments confirmed that this slipmeter is suitable only for smooth surfaces, as stated in the ASTM method.

A major difficulty in the evaluation of slipmeters is the unavailability of standard test surfaces against which they can be compared. Subjective evaluations of the slip resistances of the coated test panels would not be expected to be very accurate. Differences in slip resistance of hangar floor areas could be identified subjectively only when the areas produced large differences in measurements. No information on the probability of slipping in different areas of hangars was available. At most Naval Air Stations, considerable slipping occurs, but in the absence of serious accidents, no safety reports are generated. There is little information on the speed and direction of motion at which accidents are likely to occur.

Measurements of the slip resistances of coating system surfaces with the British Pendulum Tester are likely to provide better indications of the slip resistances than subjective evaluations and the measurements provide numerical comparisons. The NCEL Slipmeter was therefore evaluated in part by comparison with the British Pendulum Tester. This comparison of the two instruments does not imply that either one serves as a standard or provides better values than the other.

The areas measured with the British Pendulum Tester were chosen by visual and tactile inspection to be as representative as possible of the larger areas measured with the NCEL Slipmeter. In laboratory tests, a representative panel was used, and in field tests, a representative area was chosen. But differences in these areas may affect the correlations that can be obtained.

In analyzing the slip resistance data, it should be kept in mind that slip resistance values are not exact measurements. Thus, the instructions for the Horizontal Pull Slipmeter, in ASTM Method F 609, indicate that a difference of a full slip index is required to establish a significant difference. Because the slip index value is equivalent

to about 10 times the coefficient of friction, and typically is in the range of 3 to 7, an accuracy of only one significant figure is indicated. For coefficients of friction measured with the NCEL Slipmeter, differences of 0.04 appear to be significant for measurements in the range of about 0.40 to 0.80, because duplicate measurements were generally within 0.02 units. Similarly, differences of 4 units in British Pendulum numbers appear to be significant.

The static coefficients of friction were higher for oily panels than for clean panels wetted with water, even though oily floors are more slippery than clean wet floors. This is shown by the data of Table 1. The dynamic coefficients of friction were lower for oily panels than for wet panels, with rare exceptions and as expected.

The static coefficient of friction is increased by intimate contact established between the surfaces before a measurement is taken. The presence of oil between the surfaces apparently facilitates this contact much more than the presence of water, and causes the differences between the static and dynamic coefficients of friction to be much greater for the oily panels. This greater difference results in the higher static coefficients of friction for the oily panels than for the wet panels. This apparent anomaly gives further support to the choice of dynamic, rather than static, measurements for determining the safety of floors.

Similar values are obtained with the two instruments for the oily coating systems containing polypropylene grit, if the British Pendulum numbers approximate 100 times the dynamic coefficient of friction. But for coatings with alumina grit, the slip resistances are often considerably higher when measured with the NCEL Slipmeter. Polypropylene appears to be as effective in providing slip resistance as alumina when measured with the British Pendulum Tester, but less effective when measured with the NCEL Slipmeter.

The above relationship is illustrated in Figure 9, using the data of Table 1 for coating systems with polypropylene grit and those containing 45-mesh, or smaller alumina. The values for three of the coating systems containing polypro-

pylene lie on a line with a slope of 1.0. The values of a fourth system with polypropylene do not lie on this line, possibly because the area measured with the British Pendulum Tester was not a representative area. The values for the systems with alumina lie on a higher slope.

The different responses of the two slipmeters to the alumina and the polypropylene grit indicate different interactions. The difference may be related to the greater hardness and angular shape of the alumina. Perhaps the sharp edges of the protruding alumina interact more with the larger rubber contact areas of the NCEL Slipmeter. Such interactions of the alumina with the runners may cause responses quite different from those expected in the classical concept of friction, and the measured coefficients of friction may represent different physical phenomena.

The coefficients of friction of coating systems with alumina, as measured with the NCEL Slipmeter, were increased when the contact pressure was reduced. The contact pressures were reduced by decreasing the weight of the slipmeter sled or by increasing the contact area. A lower contact pressure provides a larger surface area per unit of vertical force and thus allows for greater interaction. A change in contact pressure has similar effects on the dynamic and the static coefficients of friction. Effects of loading are much smaller and sometimes not significant for the coating systems containing polypropylene.

The above relationships are demonstrated by the results obtained by using the 10-kg and 10-lb sleds with 50-sq-cm and 10-sq-cm runner areas on oily surfaces, which are reported in Table 2. The coefficient of friction increases as the load is decreased without change in runners (from 33H to 33L for the triple runners, or DH to DL for the double runners). The coefficient of friction also increases as the area is increased without change in weight (from 33H to DH for the heavy sled, or 33L to DL for the light sled).

When the area of the triple feet was reduced from a total of 10 sq cm to a total of 3 sq cm, the measured dynamic coefficients of friction of the oily coatings with alumina were further decreased.

Changes in configuration to wider but shorter feet of the same total area did not produce further significant changes.

The above changes are shown in Table 3. Some of the measured slip resistances for coatings with alumina are plotted in Figure 10. Comparative measurements with the British Pendulum Tester and the NCEL Slipmeter with the smaller feet produce values that come close to being on a line with a slope of 1.0.

The dynamic coefficient of friction generally increases with decreasing speed, as shown by the data of Tables 1 to 3. As shown in Table 3, it does not appear to increase very significantly as the speed is dropped below 1250 cm per min. The speed of the platen of the British Pendulum Tester is about double that of the highest speed of the NCEL Slipmeter. However, the available data do not indicate better correlation at the higher speeds. The only set of measurements that indicate better correlation between these instruments at 5000 cm per min are the measurements of the oily systems with polypropylene on the hangar floor, as shown in Table 4.

The concept of the layout of the NCEL Slipmeter with the three 1-cm-square feet is similar to that of the Horizontal Pull Slipmeter, which has three round feet. But the NCEL Slipmeter has feet that are beveled toward the front and thus are suitable for dynamic measurements. The concept of the layout of the NCEL Slipmeter with the three feet that are were very wide and short would approximate the wide and short contact surface of the platen of the British Pendulum Tester. The interaction with the floor surface might then be similar for the two instruments. Differences might still be expected because of the greater vertical inertia of the NCEL Slipmeter.

The contact pressures of the various configurations of the NCEL Slipmeter described in Tables 2 and 3 were 1.5, 1.0, 0.45, 0.20, and 0.09 kg per sq cm (about 21, 14, 6.3, 2.8, and 1.3 psi). The contact pressures of the platen of the British Pendulum Tester range from about 2.0 to 0.9 kg per sq cm. The actual contact pressure depends on whether the wear surface of the 3-inch platen of

the pendulum, which is under a 2500-gm spring load, is at its original width of 1/16 inch (1.5 mm) or has been worn to its maximum allowable width of 1/8 inch (3 mm). The contact pressure of the Horizontal Pull Slipmeter (three feet each 1/2 inch (12.7 mm) in diameter and weight of 2.7 kg), is 0.71 kg per sq cm.

Measurements of the static slip resistance obtained on a hangar floor with the Horizontal Pull Slipmeter do not correlate with the dynamic slip resistance measurements obtained with the British Pendulum Tester and the NCEL Slipmeter. This lack of correlation is evident by inspection of the data presented in Table 4.

Other relationships in the slip resistance measurements on the hangar floor are similar to those observed for test panels. The measured coefficients of friction obtained with the long feet are significantly higher than those obtained with the short feet for the coating systems with alumina, except for System 4A, which contains very fine alumina. The differences are negligible for the coatings with polypropylene. Whether the measurements with the short or long feet more accurately reflect the safety of the floor is not known. This may depend on the contact pressure at the time of slippage, and it may be different for personnel and equipment.

Slip resistances obtained with the NCEL Slipmeter using short and long feet at 1250 cm per min and with the British Pendulum Tester for oily thin-film coating systems and for thicker systems are shown graphically in Figure 11. Similar comparisons of measurements with the NCEL Slipmeter at 5000 cm per min are shown in Figure 12. Measurement results with the short and long triple feet of the NCEL Slipmeter also are compared in Table 5.

### **NCEL Slipmeter Operation**

The following are observations related to the measurement of the dynamic coefficient of friction with the NCEL Slipmeter. In the laboratory these measurements were made with six panels clamped end to end in a holder. This provided

discontinuities that were sometimes reflected in the reduction of the friction forces recorded on the chart. These changes may be related to reduced surface contact or to changes in the distribution of oil.

Some of the sets of test panels showed considerable variation in grit content between the panels of one set. When panels with an average amount of grit were placed first, followed by panels with less grit, and then by panels with more grit, the corresponding average, low, and high friction forces were recorded in the chart traces.

There appears to be no advantage to the use of the 10-kg sled instead of the 10-lb sled. The lighter sled is easier to use, especially in a field instrument, and a 10-lb digital force gauge is commercially available. The triple runners appear to give better contact on rough surfaces than the double runners. There appears to be no clear advantage to the use of either the longer or shorter triple feet. The smaller triple feet, each with 1-cm-sq contact area, provide the highest practical contact pressure. Shorter and wider feet (for example, 4 mm long and 25 mm wide) more closely approximate the contact area of the British Pendulum Tester (about 2 mm by 75 mm), but the correlation between the instruments is not improved. The contact area of these short feet changes more rapidly when they are used on abrasive surfaces.

The coefficient of friction decreases as the speed is increased from 1250 cm per min to 5000 cm per min. At the higher speeds, a jumping and irregular movement of the sled sometimes occurs, which reduces the force required to keep the sled moving and therefore further reduces the coefficient of friction. Except in such instances, the relative values for different coating systems are not greatly affected by the change in speed.

The slower speed of 1250 cm per min provides a longer recording period, better response on the strip chart recorder, and a trace that is easier to read and average. The visual averaging at the slower speed can be facilitated by placing an RC circuit at the recorder input to dampen the

---

response. At higher speeds, the damping may cause too much reduction in sensitivity. Because of the less powerful motor required, the slower speed would reduce the cost of a field instrument.

## SLIPMETER FOR FIELD USE

In consideration of the results discussed above, a conceptual slipmeter is proposed for field measurements of reflective floor coatings. This slipmeter uses the sled of the NCEL Slipmeter, pulled by a force gauge mounted on a small electrically driven cart. The cart is similar to a lawnmower in configuration, with a constant speed motor sitting over two large front driving wheels. A microprocessor control box at the handle starts the cart, averages the force reading for a few seconds after the cart is up to speed, and stops the cart by turning off the power and applying a brake. This concept is illustrated in Figure 13. The sled for this slipmeter is illustrated in Figure 14.

The following conditions would apply: The sled is the 10-lb configuration with three 1-by-1-cm or 1-by-3.3-cm runners, beveled at the leading edge. The force gauge is a Chatillon digital instrument (Model DFG 10) mounted close to the floor. The cart speed is 1250 cm per min (1/2 mph), and the force reading is averaged for about 6 seconds, while the slipmeter travels 125 cm (about 4 feet). By pushing down on the handle, the front wheels can be lifted off the floor to place the force gauge in a vertical position. This will allow the force gauge to be calibrated while the sled hangs from it and will allow the microprocessor to be tested.

An applicator could be provided at the front of the instrument to wet the floor surface that will be measured. It may be desirable to apply a detergent solution, rather than oil. Like the oil, the detergent solution will provide typically slippery floors, but it can be removed more easily, by simple rinsing. Use of the detergent solution would also reduce floor preparation time before the measurements are made, because it would

eliminate the requirement for drying the floor after it is cleaned. With a detergent applicator, the slip resistances of long paths along the floor could be measured.

Refinements of the above slipmeter concept should produce a slipmeter that is better suited than any now available for specifying slip resistance requirements of newly applied coating systems or for determining when the floor is no longer safe and recoating is necessary.

A very rough cost estimate for a production model of the conceptual slipmeter is about \$1000 each for the sled and extra plate with runners, the digital force gauge, the motorized cart, and the microprocessor system; that is, a total of about \$4000. The cost may thus be less than the purchase price of about \$7000 of the British Pendulum Tester.

## CONCLUSIONS

1. No commercial slipmeter for the measurement of the slip resistance of textured coated floors is available that is suitable for field use by persons not highly trained.
2. The best commercially available instrument is the British Pendulum Tester, but this instrument requires a trained technician and it measures only a small area.
3. An instrument that can measure a longer path and determine variations in slip resistance is preferable to an instrument that can only measure a small area.
4. The NCEL Slipmeter is a versatile instrument for measuring the slip resistance of textured coated floors, and presumably also of other textured floors.
5. The conceptual slipmeter proposed in this report, which is based on the NCEL Slipmeter, would be suitable for use by field personnel.

---

6. The dynamic slip resistance of coated floors, rather than the static slip resistance, should be measured to determine their safety.

### RECOMMENDATIONS

1. It is recommended that the NCEL Slipmeter be developed commercially as a field instrument for the measurement of the slip resistance of reflective floor coatings for aircraft maintenance hangars and jet engine test cells.

2. It is recommended that the NCEL Slipmeter be investigated for the measurement of the slip resistance of aircraft carrier decks.

3. It is recommended that the American Society for Testing and Materials (ASTM) consider the NCEL Slipmeter for a method of measurement of the coefficient of friction of coarse-textured coated floors.

### REFERENCES

1. Ernest Rabinowicz, "Stick and slip," *Scientific American Journal*, vol 194, no. 5, May 1956, p 109.

2. National Bureau of Standards. Technical Note 895: An overview of slip-resistance research with annotated bibliography, by Robert J. Brungraber, Washington, DC, Jan 1976.

3. American Society for Testing and Materials. ASTM Special Technical Publication No. 649, Walkway surfaces: Measurement of slip resistance. Philadelphia, PA, 1978.

4. W. H. Kummer, and W. E. Meyer, "Measurement of skid resistance," Symposium on skid resistance, in American Society for Testing and Materials Special Technical Publication No. 326, pp 3-28. Philadelphia, PA, 1962.

5. Naval Civil Engineering Laboratory. Technical Report R-933: Reflective coatings for hangar floors: performance of coating system designs, by Peter J. Hearst, Port Hueneme, CA, Mar 1991.

Table 1. Slip Resistance Comparisons for Test Panels\*

System	Components	BPT (BPN)		NCEL Slipmeter (COF)							
				Water				Oil			
		Wtr	Oil	0	1250	2500	5000	0	1250	2500	5000
V3	A30H1	57	61	1.08	0.64	0.72	0.65	1.22	0.65	0.65	0.61
V5	A30H2	54	56	1.03	0.59	0.60	0.62	1.20	0.60	0.58	0.57
V24	A30M1	58	48	1.04	0.68	0.63	0.61	1.15	0.63	0.58	0.57
V25	A30M1	55	45	1.01	0.69	0.66	0.63	1.13	0.61	0.58	0.58
V2	A30M1	63	52	1.02	0.71	0.66	0.68	1.30	0.68	0.56	0.54
V4	A30M2	54	49	0.99	0.66	0.62	0.60	1.20	0.56	0.56	0.53
V6	A30M3	44	39	0.85	0.56	0.56	0.58	1.08	0.57	0.56	0.54
V1	A30L1	54	46	-	-	-	-	1.26	0.64	0.57	0.55
V12	A45H1	48	46	0.95	0.70	0.67	0.67	1.14	0.70	0.68	0.65
V14	A45H2	42	40	0.90	0.69	0.75	0.73	1.11	0.64	0.61	0.58
V11	A45M1	49	37	0.94	0.75	0.73	0.69	1.02	0.65	0.61	0.60
V13	A45M2	41	24	0.97	0.74	0.74	0.72	0.96	0.53	0.50	0.47
V15	A45M3	33	23	0.88	0.53	0.54	0.53	0.96	0.46	0.44	0.44
V9	A60H1	39	34	0.87	0.64	0.69	0.73	1.01	0.60	0.59	0.59
V8	A60M1	41	32	0.83	0.53	0.57	0.60	1.05	0.54	0.50	0.52
V32	A80M1	33	21	0.72	0.58	0.59	0.59	0.91	0.37	0.34	0.35
A12	P90V1	57	46	0.82	0.71	0.65	0.58	1.10	0.50	0.46	0.43
G14	P90H1	47	40	0.90	0.66	0.63	0.57	1.00	0.42	0.39	0.34
G13	P90M1	47	40	0.87	0.66	0.62	0.56	1.06	0.42	0.39	0.37
G12	P90L1	36	28	0.85	0.66	0.61	0.56	0.89	0.43	0.40	0.37

\*Slip resistance values obtained with the British Pendulum Tester (BPT), in British Pendulum numbers (BPN), and with the NCEL Slipmeter, as coefficients of friction (COF) using the 10-kg sled with double runners, on coating surfaces wetted with water or with oil.

Sled speeds: 0 = static, 1250 = 1250 cm per min, 2500 = 2500 cm per min, 5000 = 5000 cm per min.

Coating system components:

First character - Grit type: A = alumina, P = Polypropylene.

Second and third characters - Grit size: Sieve No. on which retained (except that 90 represents a spherical pigment of 200 µm average diameter).

Fourth character - Grit density: L = low, M = medium, H = heavy, V = very heavy.

Fifth character - Grit coverage: number of topcoats over coat with grit.

Table 2. Effect of Loading and Configuration\*

System	Components	BPT (BPN)	NCEL Slipmeter (COF)															
			1.0 kg (33H)				.45 kg (33L)				.20 kg (DH)				.09 kg (DL)			
			0	1250	2500	5000	0	1250	2500	5000	0	1250	2500	5000	0	1250	2500	5000
V2	A30M1	52	1.05	0.63	0.56	0.50	1.30	0.73	0.65	0.62	1.34	0.66	0.64	0.59	1.34	0.83	0.76	0.65
V4	A30M2	49	0.98	0.56	0.52	0.48	1.09	0.66	0.62	0.54	1.31	0.67	0.63	0.60	1.30	0.80	0.74	0.69
V1	A30L1	46	0.80	0.48	0.44	0.41	0.93	0.59	0.56	0.51	1.26	0.64	0.57	0.55	1.32	0.78	0.73	0.68
V12	A45H1	46	0.98	0.59	0.56	0.52	1.14	0.70	0.66	0.65	1.20	0.75	0.70	0.68	1.28	0.79	0.75	0.67
V14	A45H2	40	0.87	0.46	0.44	0.42	1.00	0.58	0.55	0.52	1.17	0.68	0.65	0.62	1.24	0.77	0.72	0.64
V9	A60H1	34	0.88	0.51	0.48	0.46	0.98	0.65	0.60	0.57	1.11	0.70	0.66	0.60	1.21	0.77	0.75	0.71
V8	A60M1	32	-	-	-	-	0.98	0.54	0.50	0.46	-	-	-	-	1.22	0.74	0.70	0.63
A12	P90V1	46	1.06	0.49	0.46	0.38	0.97	0.49	0.45	0.41	1.11	0.50	0.44	0.41	1.12	0.44	0.40	0.35
G14	P90H1	40	0.97	0.40	0.37	0.34	1.01	0.41	0.38	0.33	1.00	0.42	0.39	0.34	1.02	0.43	0.37	0.33
G12	P90L1	28	0.76	0.33	0.30	0.30	0.83	0.41	0.38	0.36	0.89	0.43	0.40	0.37	1.05	0.44	0.39	0.33

\*Slip resistance values obtained with the British Pendulum Tester (BPT), in British Pendulum numbers (BPN), and with the NCEL Slipmeter, as coefficients of friction (COF), on coating surfaces wetted with oil.

Loadings indicated were obtained as follows:

1.0 kg per sq cm = three runners, each 33x10 mm and totaling 10 sq cm, with heavy sled weighing 10 kg (33H);

0.45 kg per sq cm = three runners with light sled weighing 10 lb (33L);

0.20 kg per sq cm = double runners, each 12.5x2 cm and totaling 50 sq cm, with heavy sled (DH);

0.09 kg per sq cm = double runners with light sled (DL).

Sled speeds: 0 = static, 1250 = 1250 cm per min, 2500 = 2500 cm per min, 5000 = 5000 cm per min.

Coating system components:

First character - Grit type: A = alumina, P = Polypropylene.

Second and third characters - Grit size: Sieve No. on which retained (except that 90 represents a spherical pigment of 200- $\mu$ m average diameter).

Fourth character - Grit density: L = low, M = medium, H = heavy, V = very heavy.

Fifth character - Grit coverage: number of topcoats over coat with grit.

(Values for the oily systems V2, V4, V9, V12, and V14, at loadings of .20 kg, were obtained about two years later and differ slightly from those in Table 1.)

Table 3. Effect of Configuration of Triple Feet\*

System	Components	BPT (BPN)	NCEL Slipmeter (COF)														
			1.5 kg (4L)						1.5 kg (5L)			1.5 kg (10L)			.45 kg (33L)		
			155	310	625	1250	2500	5000	1250	2500	5000	1250	2500	5000	1250	2500	5000
V4	A30M2	52	-	-	-	-	-	-	0.51	0.45	0.44	0.47	0.44	0.41	0.68	0.61	0.59
V12	A45H1	46	0.62	0.61	0.61	0.56	0.52	0.46	0.57	0.54	0.49	-	-	-	0.70	0.66	0.65
V14	A45H2	40	0.52	0.49	0.47	0.43	0.39	0.33	0.46	0.40	0.35	-	-	-	0.58	0.55	0.52
	same w/DFG	40	-	-	-	0.46	0.44	0.42	-	-	-	0.45	0.42	0.41	0.60	0.57	0.56
V9	A60H1	39	-	-	-	-	-	-	0.46	0.44	0.42	0.47	0.44	0.42	0.62	0.59	0.57
A12	P90V1	46	-	-	-	0.49	0.45	0.37	0.46	0.43	0.38	-	-	-	0.49	0.45	0.41

\*Slip resistance values obtained with the British Pendulum Tester (BPT), in British Pendulum numbers (BPN), and with the NCEL Slipmeter, as coefficients of friction (COF), using various loadings and runner configurations, on coating surfaces wetted with oil.

Loadings indicated were obtained as follows:

1.5 kg/sq cm - three runners totaling 3 sq cm of contact area with light sled weighing 10 lb (4.5 kg), where (4L) = runners 4 mm long by 25 mm wide, (5L) = runners 5 mm long by 20 mm wide, and (10L) = runners 10 mm square;

0.45 kg/sq cm - three runners totaling 10 sq cm, each 33 mm long by 10 mm wide (33L).

Sled speeds: Numbers are speeds in cm per min; for example, 1250 = 1250 cm per min.

Coating system components:

First character - Grit type: A = alumina, P = Polypropylene.

Second and third characters - Grit size: Sieve No. on which retained (except that 90 represents a spherical pigment of 200-µm average diameter).

Fourth character - Grit density: M = medium, H = heavy, V = very heavy.

Fifth character - Grit coverage: number of topcoats over coat with grit. "same w/DFG" is System V14 measured with a digital force gauge.

Table 4. Slip Resistance Measurements on Hangar Floors\*

Ctng Syst	HPS (SI) Dry	BPT (BPN)		NCEL Slipmeter (COF)													
				Water			Oil			Oil							
				Water	Oil		Short Feet			Long Feet			Short Feet			Long Feet	
			1250	2500	5000	1250	2500	5000	1250	2500	5000	1250	2500	5000	1250	2500	5000
1S	6.6	38	22	0.70	0.62	0.55	0.64	0.56	-	0.43	0.39	0.27	0.39	0.36	0.24		
1N	6.4	34	25	0.45	0.40	0.36	0.43	0.38	-	0.32	0.29	0.27	0.31	0.27	0.25		
2S	5.3	42	31	0.63	0.59	0.56	0.62	0.58	0.51	0.39	0.36	0.33	0.36	0.34	0.31		
2N	5.7	42	30	0.66	0.61	0.54	0.61	0.56	0.51	0.33	0.31	0.30	0.34	0.30	0.30		
3S	9.3	56	46	0.73	0.70	0.64	0.86	0.83	0.77	0.46	0.39	0.36	0.64	0.61	0.57		
3N	9.0	64	58	0.88	0.84	-	1.01	-	-	0.66	0.59	-	0.79	-	-		
3D	6.7	47	43	0.52	0.51	0.46	0.69	0.64	0.58	0.40	0.37	0.34	0.48	0.45	0.43		
3E	8.1	52	49	0.75	0.72	0.62	0.87	0.83	0.76	0.54	0.48	0.42	0.66	0.61	0.59		
3F	7.9	53	49	0.64	0.62	0.56	0.83	0.77	0.72	0.56	0.52	0.46	0.68	0.65	0.60		
4A	7.0	42	33	0.66	0.64	0.60	0.72	0.65	0.65	0.50	0.45	0.44	0.45	0.38	0.42		
4S	7.7	52	49	0.64	0.61	0.58	0.85	0.80	0.78	0.50	0.46	0.44	0.68	0.64	0.61		
4N	9.1	68	60	0.88	0.89	0.82	0.98	0.95	0.92	0.67	0.62	0.59	0.79	0.75	0.74		
5S	-	49	46	-	-	-	-	-	-	0.58	0.53	0.50	0.73	0.68	0.67		
5N	-	64	57	-	-	-	-	-	-	0.70	0.65	0.62	0.80	0.76	0.75		
6S	8.2	54	47	0.76	0.77	0.71	0.61	0.87	0.85	0.50	0.44	0.43	0.66	0.62	0.62		
6N	8.5	50	43	0.76	0.72	0.69	0.88	0.85	0.81	0.48	0.45	0.42	0.65	0.62	0.58		

\*Coating systems are described briefly in Table 5 and in more detail in Reference 5. HPS = Horizontal Pull Slipmeter, SI = slip index on dry surface; BPT = British Pendulum Tester, BPN = British Pendulum number on wet and oily surfaces; COF = Coefficient of friction obtained with NCEL Slipmeter on wet and oily surfaces, using a 10-lb sled with 3 short feet (each 1x1 cm) or with 3 long feet (each 1x3.3 cm) at the following three speeds: 1250 cm/min, 2500 cm/min, and 5000 cm/min.

Table 5. Selected Slip Resistances of Oily Coating Systems\*

Coating System	Coating System Design						Slip Resistance			
	Coat 1	Grit Type	Amount (lbs)	Coat 2	Coat 3	Coat 4	BP	Short	Long	Diff
Thin-Film Systems										
1S	CRU	150 µm PP	0.5	Same	-	-	22	0.43	0.39	-.04
1N	CRU	150 µm PP	0.75	Same	-	-	25	0.32	0.31	-.01
2S	CRU	200 µm PP	1.0	CRU	-	-	31	0.39	0.36	-.03
2N	CRU	200 µm PP	2.0	CRU	-	-	30	0.33	0.34	0.01
4S	CRU	#36 Alumina	3.0	CRU	CRU	-	49	0.50	0.68	0.18
4N	CRU	#36 Alumina	6.0	CRU	CRU	-	60	0.67	0.79	0.12
5N	CRU	#46 Alumina	6.0	CRU	-	-	57	0.70	0.80	0.10
5S	CRU	#46 Alumina	6.0	CRU	CRU	-	46	0.58	0.73	0.15
6S	CRU	#54 Alumina	6.0	CRU	-	-	47	0.50	0.66	0.16
6N	CRU	#54 Alumina	6.0	CRU	CRU	-	43	0.48	0.65	0.17
Thick-Film Systems										
3S	Epoxy	#24 Alumina	6	CRU	CRU	-	46	0.46	0.64	0.18
3N	Epoxy	#24 Alumina	12	CRU	CRU	-	58	0.66	0.79	0.13
Toppings										
3D	Epoxy	16/30 Sand	Excess	Epoxy	CRU	CRU	43	0.40	0.48	0.08
3E	Epoxy	#30 Alumina	Excess	Epoxy	CRU	CRU	49	0.54	0.66	0.12
3F	Epoxy	#24 Alumina	Excess	Epoxy	CRU	CRU	49	0.56	0.68	0.12
Rolled-On Epoxy										
4A	Textured epoxy w/alumina			Same	-	-	33	0.50	0.45	-.05

\*Coating system designs are described in more detail in Reference 5; "150 µm PP" designates a popcorn-shaped polypropylene pigment of 150 µm average diameter and "200 µm PP" designates a spherical polypropylene pigment of 200 µm average diameter; amounts of grit are lb/gal for polypropylene and lb/1000 sq ft for alumina.

Slip Resistance values are British Pendulum numbers (BP) and coefficients of friction (obtained with the NCEL Slipmeter with short and long feet at 1250 cm/min, and their differences) measured on oily surfaces.



Figure 1.  
Horizontal Pull Slipmeter.

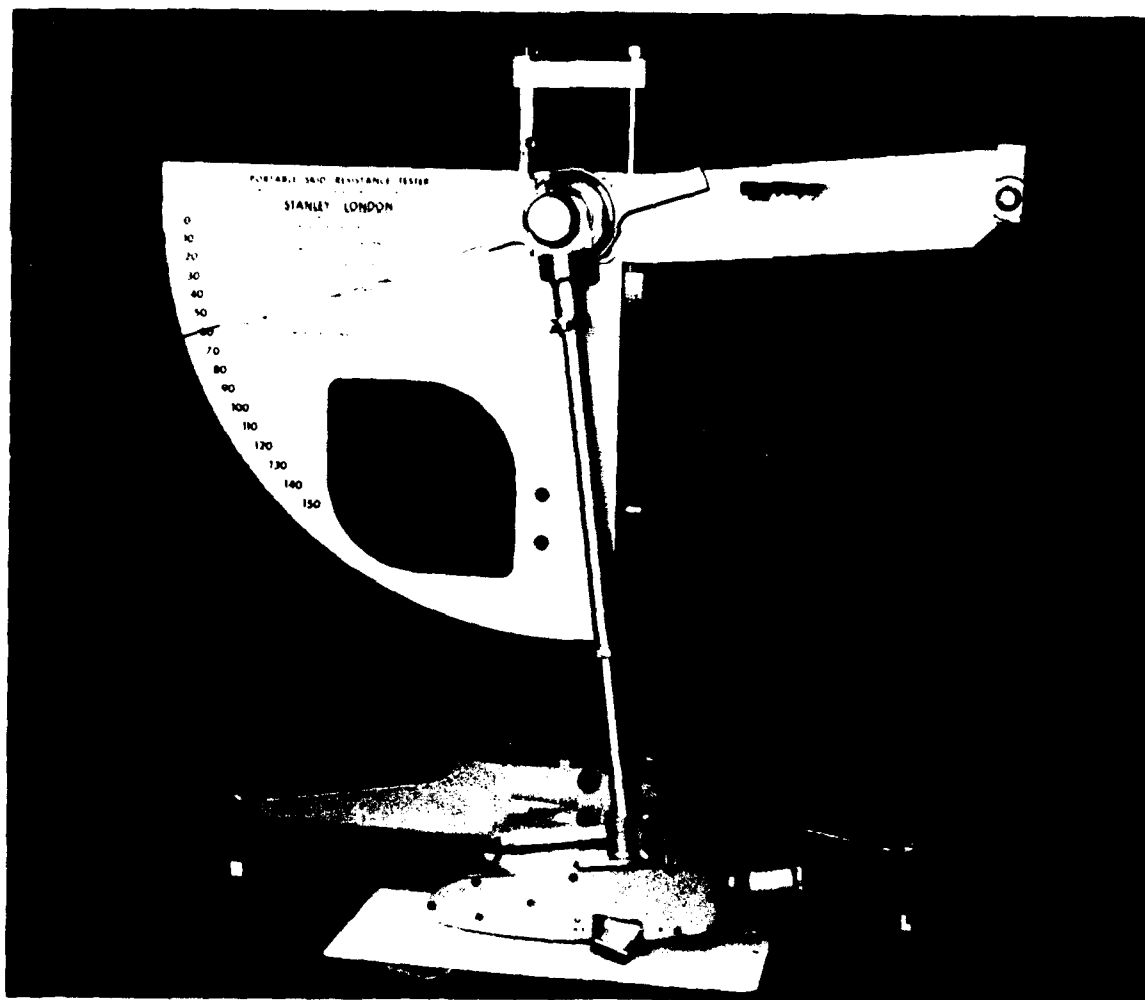

Figure 2.  
British Pendulum Tester.

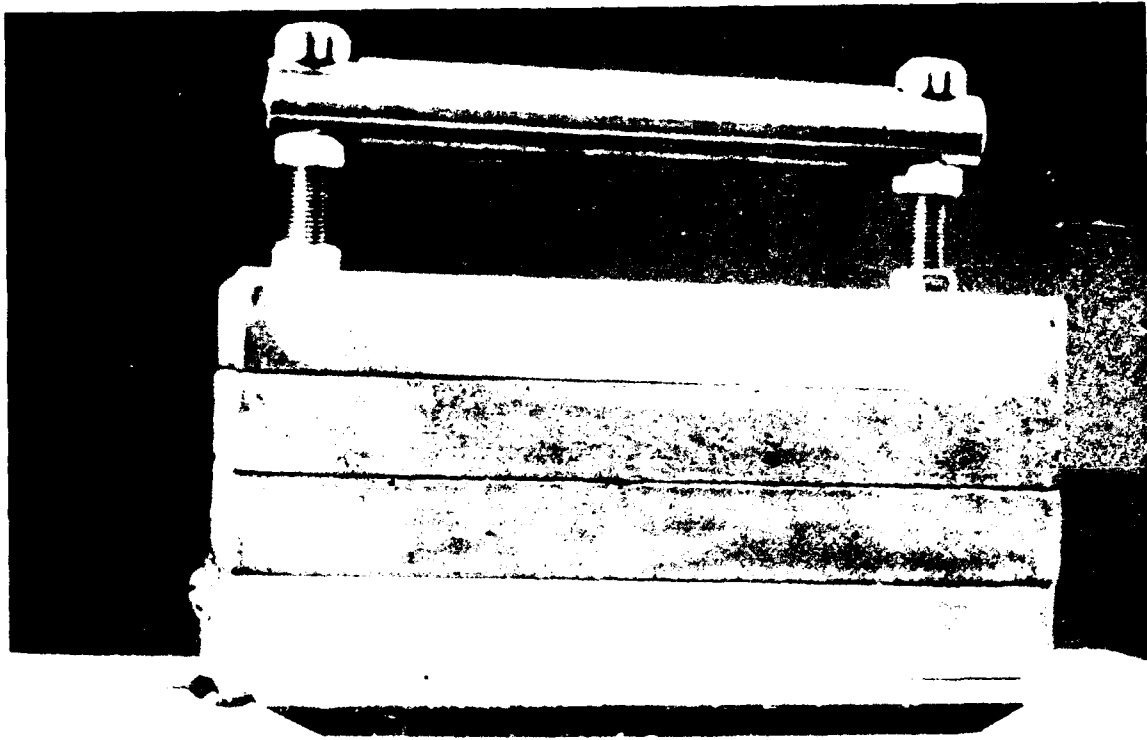

Figure 3.  
Heavy sled of NCEL Slipmeter.

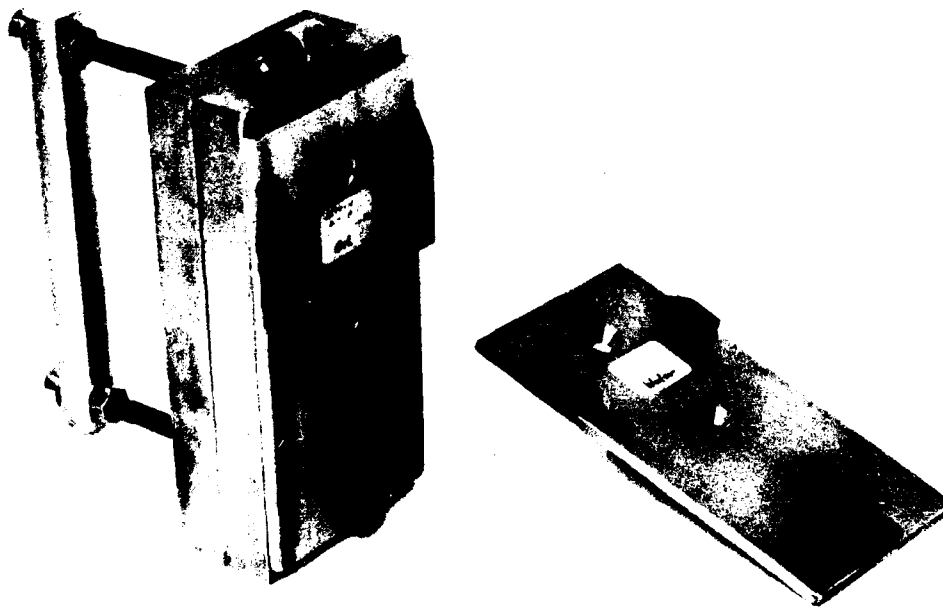

Figure 4.  
Light sled of NCEL Slipmeter.

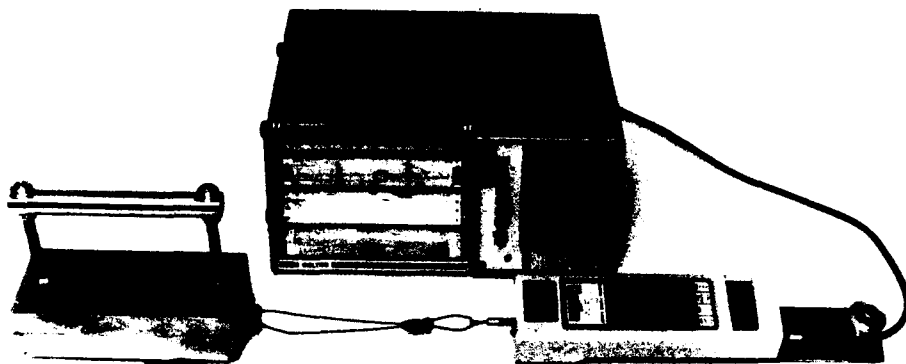

Figure 5.  
Light sled with instrumentation.

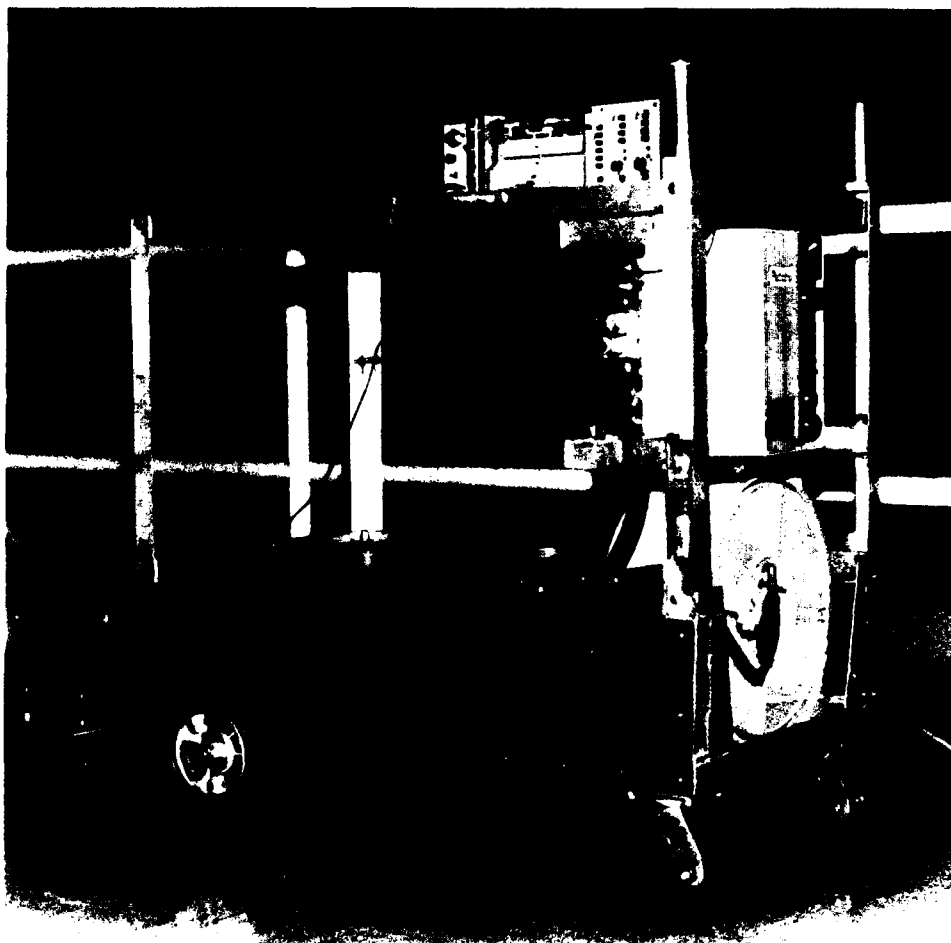

Figure 6.  
Front view of cart for NCEL Slipmeter.

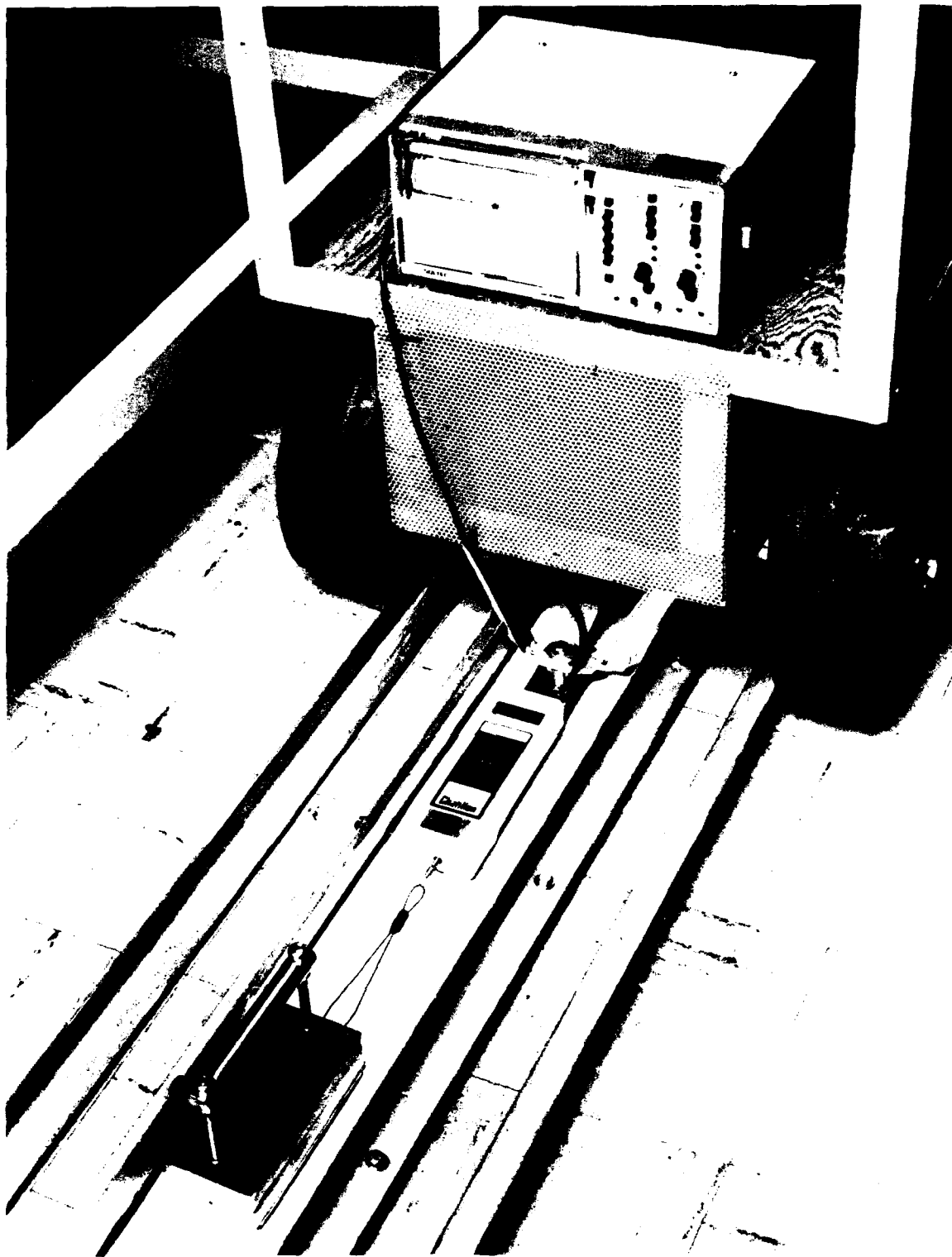

Figure 7.  
Rear view of cart for NCEL Slipmeter.

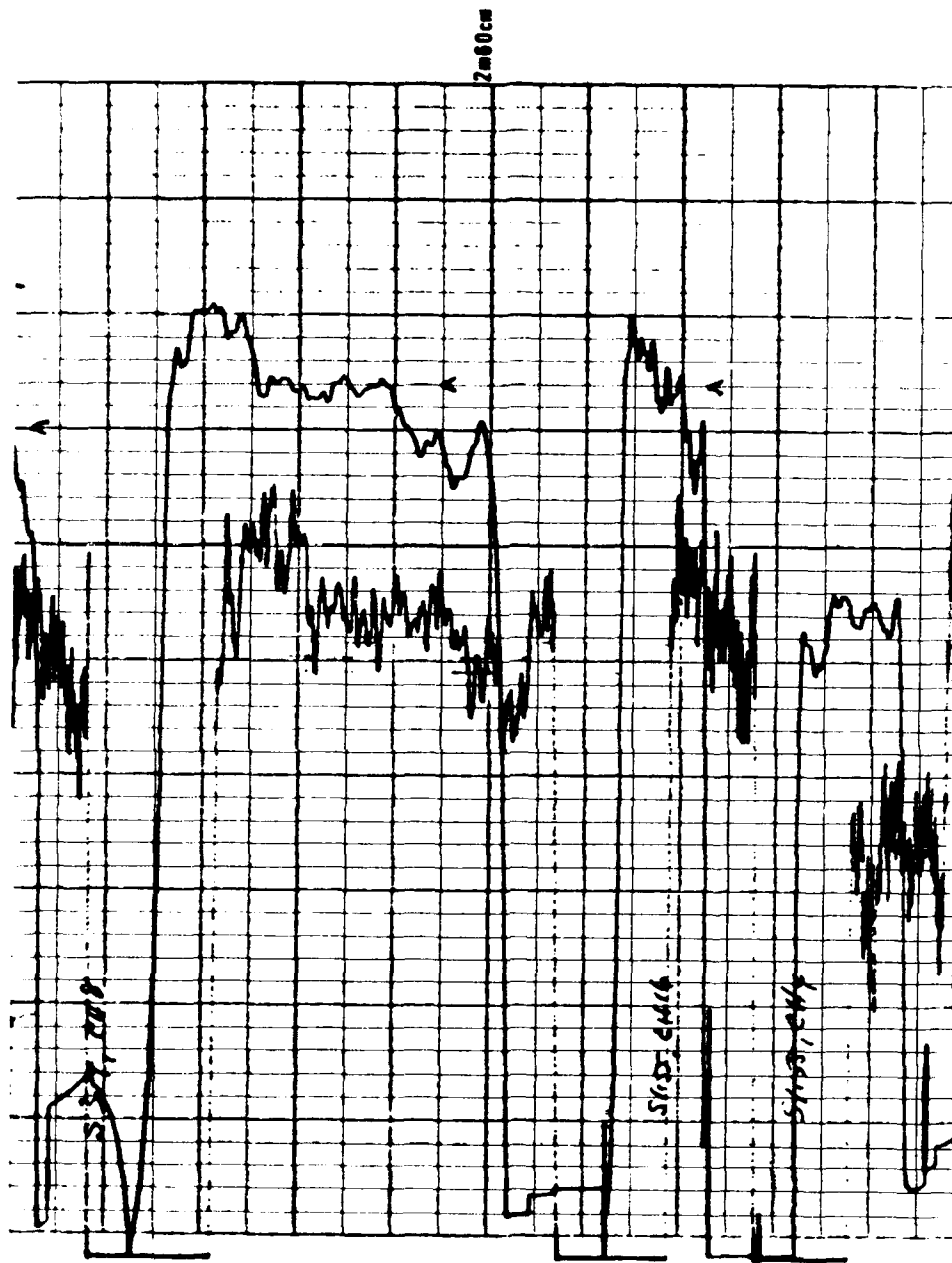

Figure 8.  
 Sample NCEL Slipmeter recorder traces.  
 [Undampened and offset dampened 15-mm-wide traces and replicate  
 60-mm-wide traces for oily System 4N at 1250 cm per min]

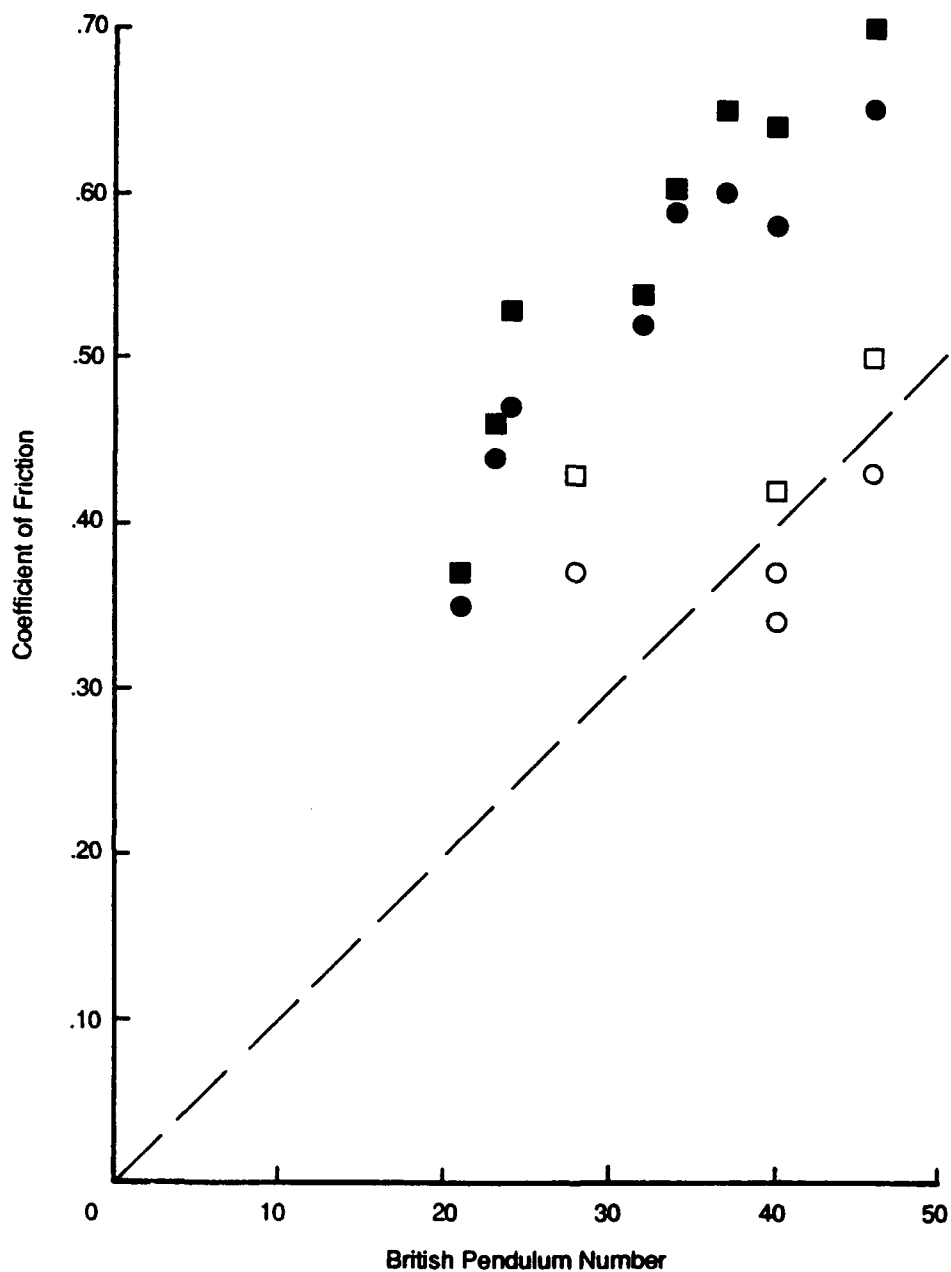

Figure 9.

Slip resistance of coating systems with alumina and with polypropylene.

- Systems with alumina and NCEL Slipmeter at 1250 cm per min
- Systems with alumina and NCEL Slipmeter at 5000 cm per min
- Systems with polypropylene and NCEL Slipmeter at 1250 cm per min
- Systems with polypropylene and NCEL Slipmeter at 5000 cm per min

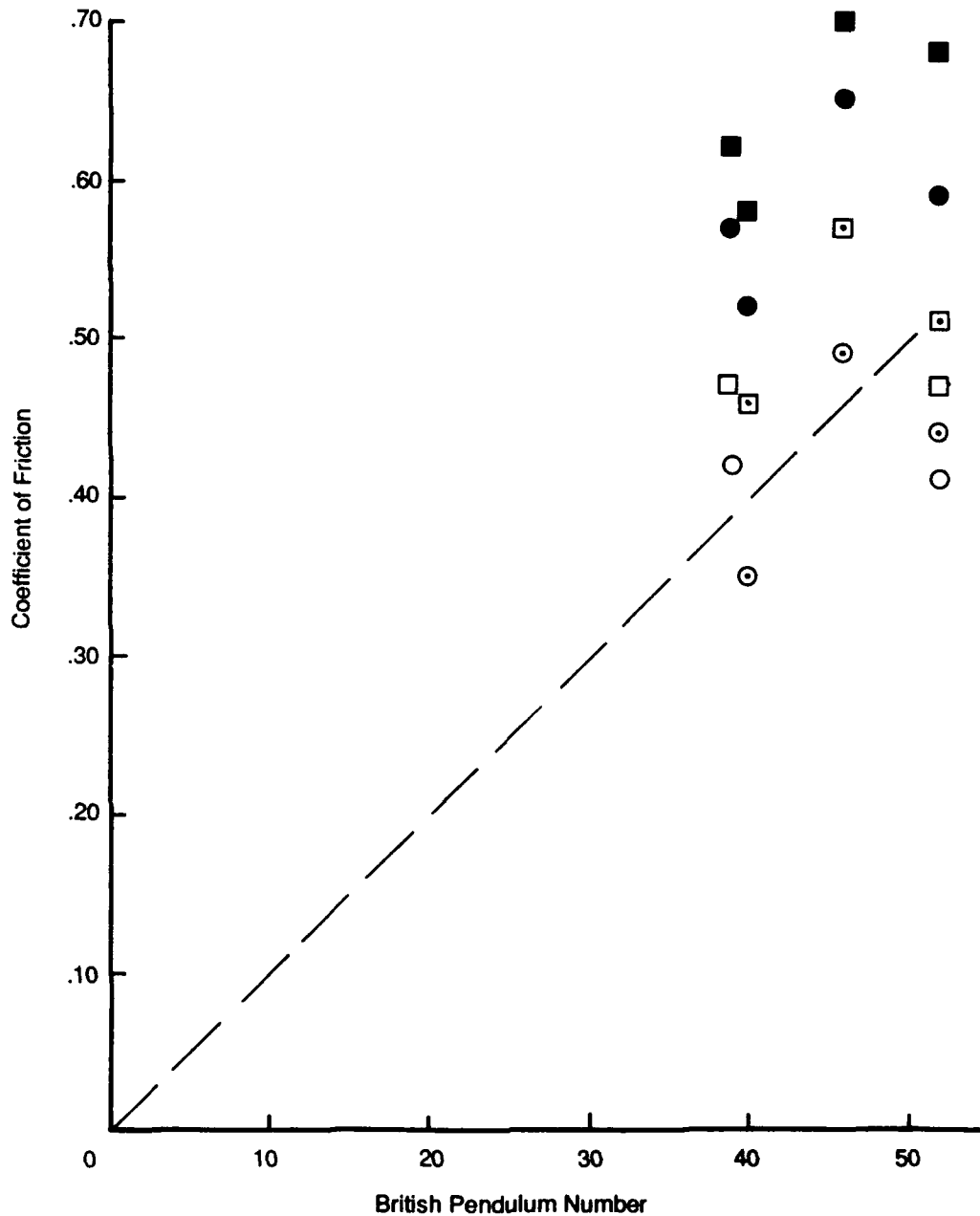
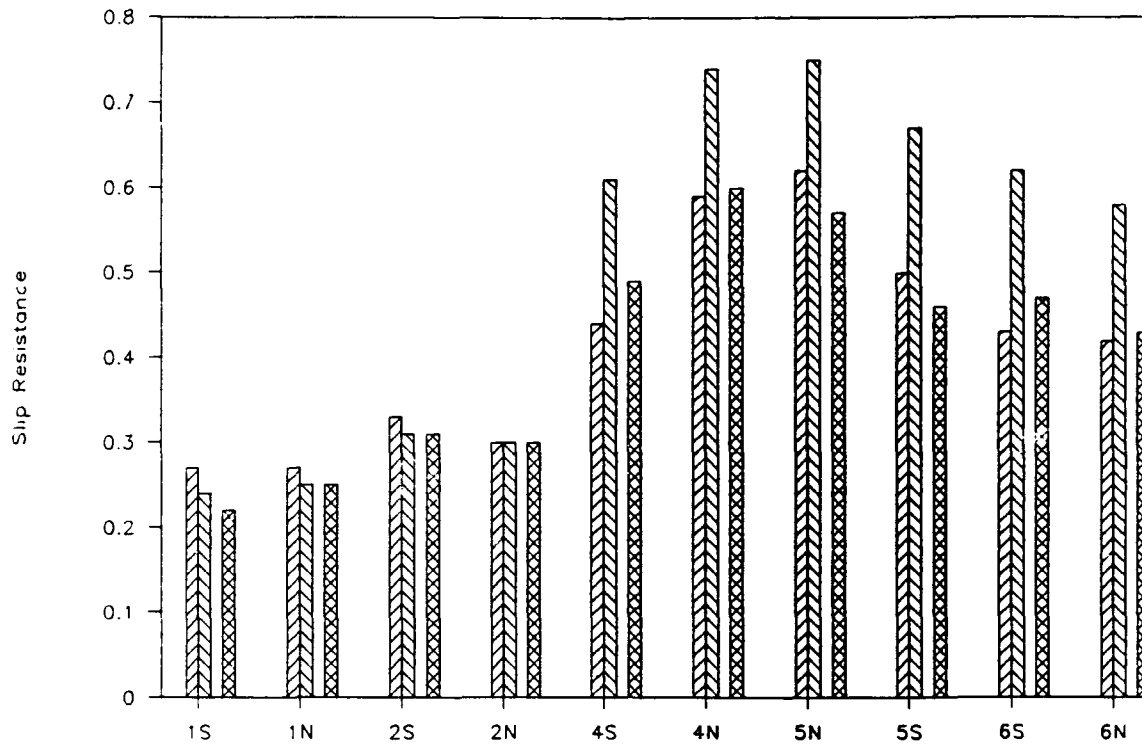

Figure 10.

Effect of short and long feet on the measured slip resistance of coating systems with alumina.

- NCEL Slipmeter with 33x10-mm feet 1250 cm per min
- NCEL Slipmeter with 33x10-mm feet 5000 cm per min
- NCEL Slipmeter with 10x10-mm feet 1250 cm per min
- NCEL Slipmeter with 10x10-mm feet 5000 cm per min
- ◻ NCEL Slipmeter with 5x20-mm feet 1250 cm per min
- ⊙ NCEL Slipmeter with 5x20-mm feet 5000 cm per min



A. Oily Thin-Film Coating System

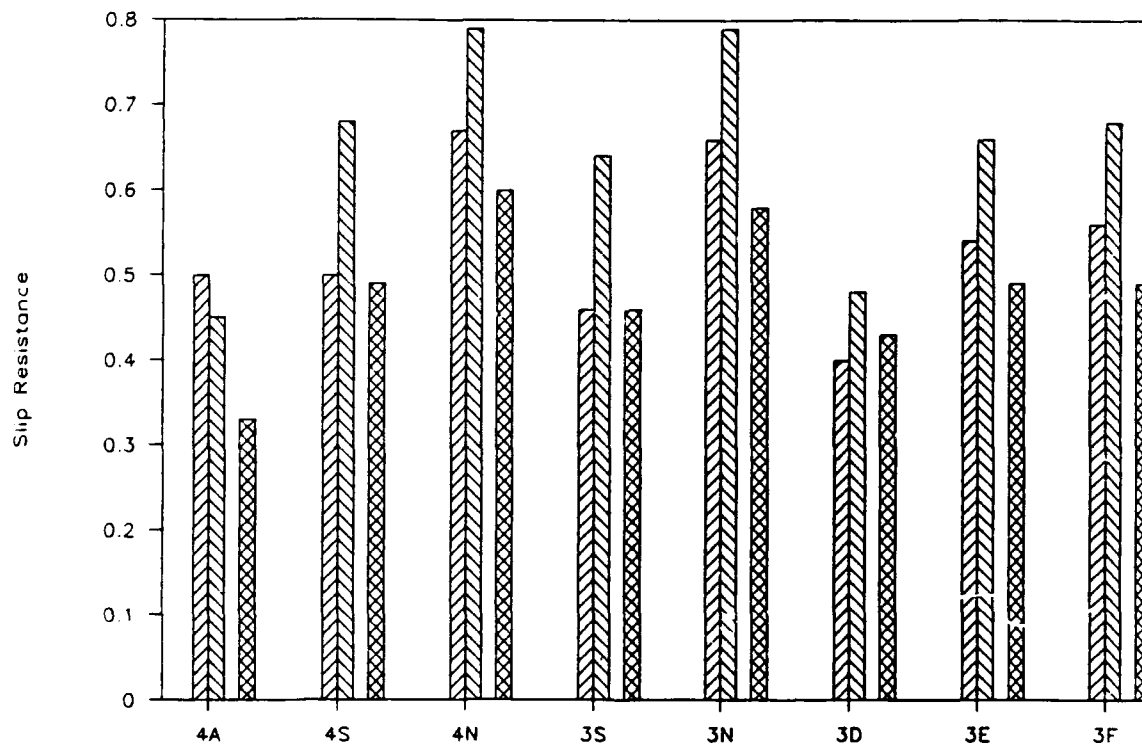

B. Oily Thicker Coating System

Coating Systems and Measurements

COF (Short Ft, 1250)    
 COF (Long Ft, 1250)    
 BPN /100

Figure 11.

Slip resistance of hangar floors using the NCEL Slipmeter at 1250 cm per min and the British Pendulum Tester.

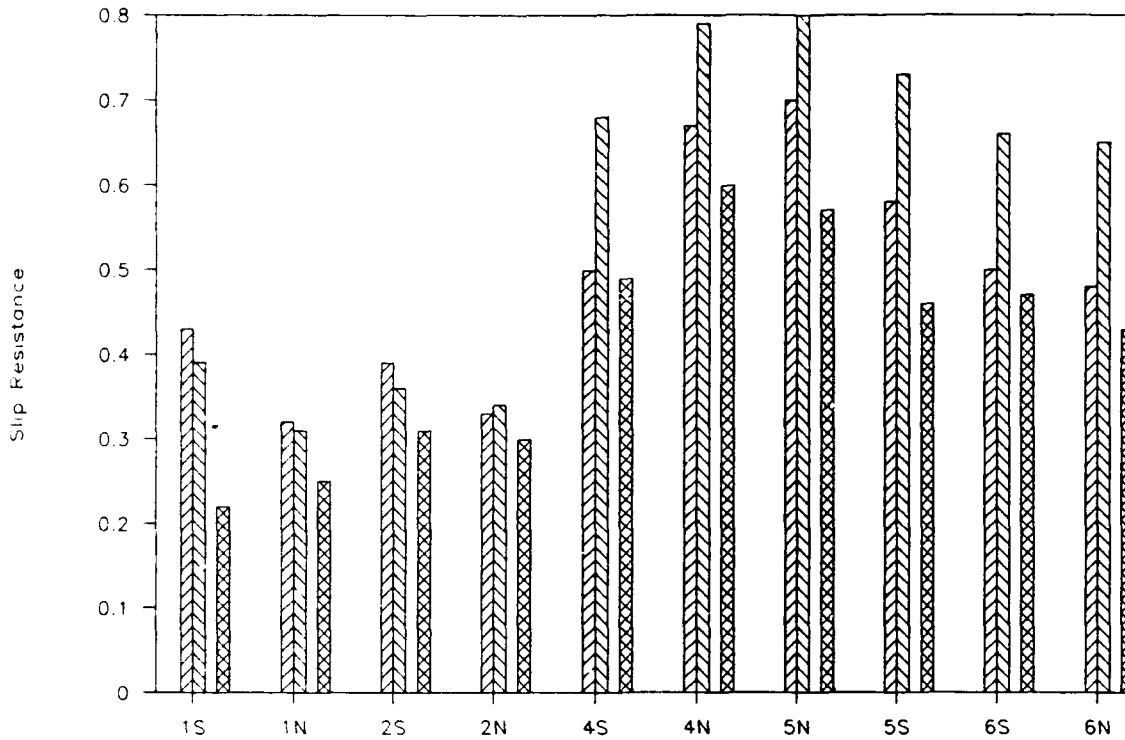

A. Oily Thin-Film Coating Systems

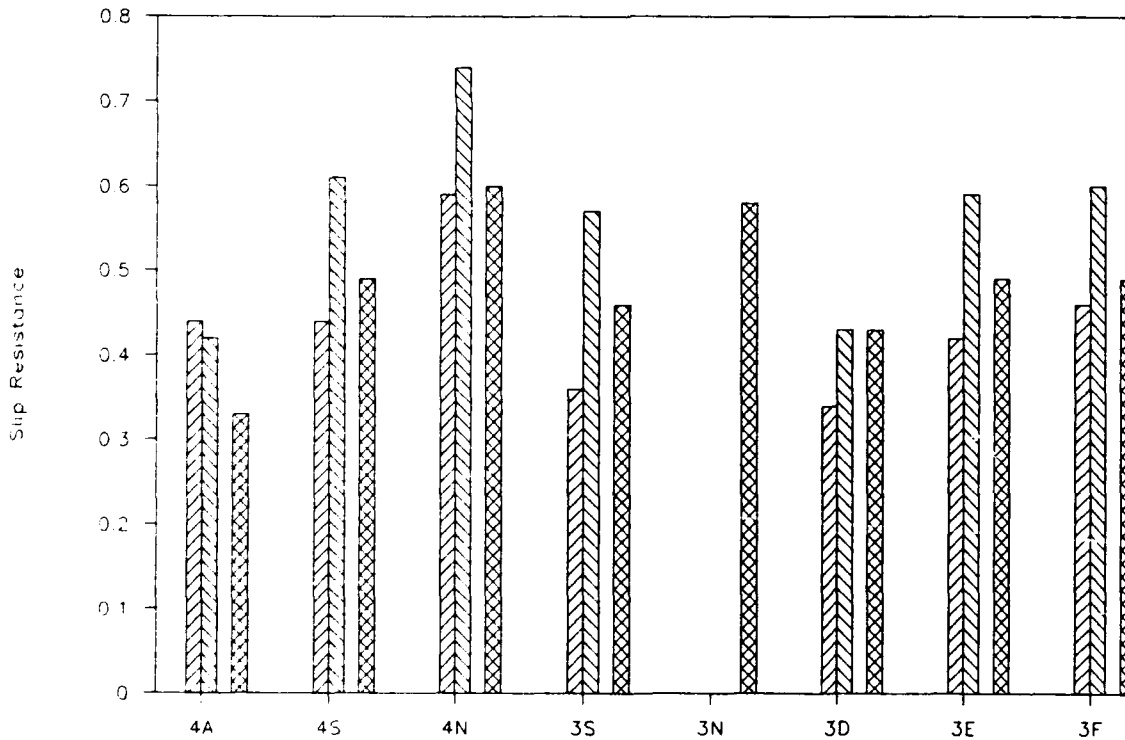

B. Oily Thicker Coating Systems

Coating Systems and Measurements  
 ▨ COF (Short Ft, 5000)    ▩ COF (Long Ft, 5000)    ⊞ BPN /100

Figure 12.  
 Slip resistance of hangar floors using the NCEL Slipmeter  
 at 5000 cm per min and the British Pendulum Tester.

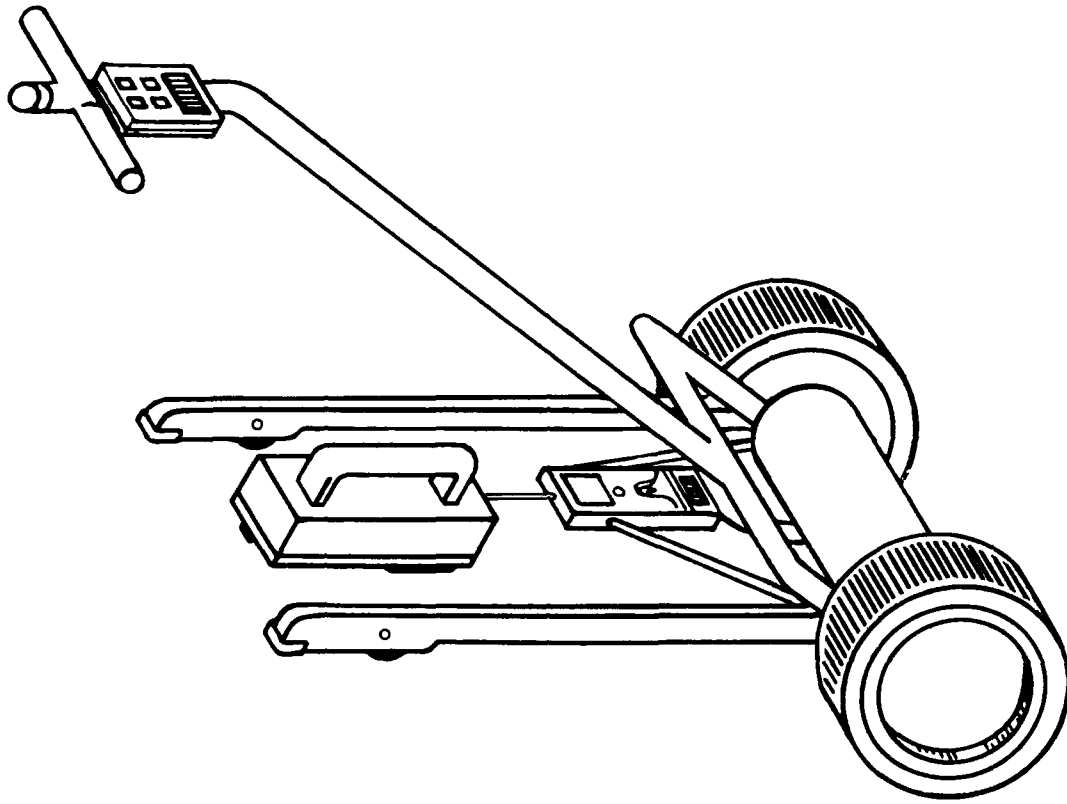

Figure 13.  
Conceptual slipmeter for field use.

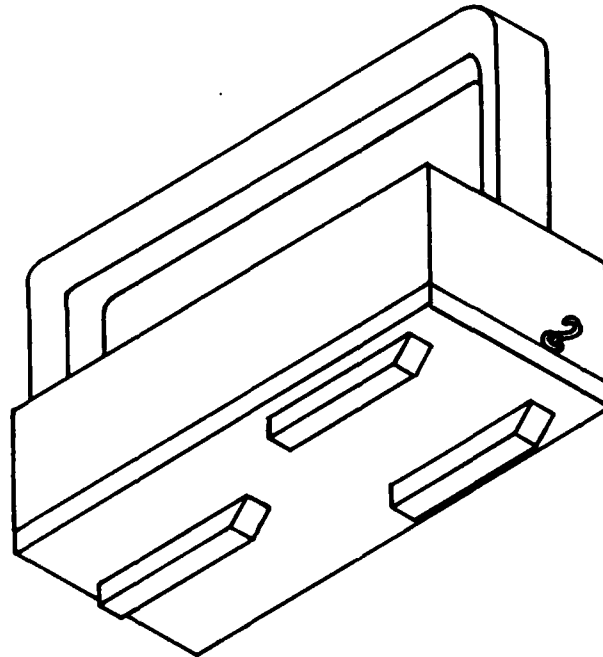

Figure 14.  
Sled for conceptual slipmeter.

## DISTRIBUTION LIST

AFESC / DEMM, Tyndall AFB, FL  
ASHTON, HARRY E. / Gloucester, Ontario, Canada  
ASTM / Philadelphia, PA  
AT&T TECHNOLOGIES / Union, NJ  
BALL, HENRY A. / Glenshaw, PA  
CANADA NATIONAL DEFENSE / Ottawa, Ontario, Canada  
CASE WESTERN RESERVE UNIV / Cleveland, OH  
CONSUMERS UNION / Mount Vernon, NY  
CREATIVITY, INC. / Beverly, MA  
D/L LABS / New York, NY  
E.I. DUPONT DE NEMOURS CO. / Philadelphia, PA  
EUVERARD, MAYNARD R. / Williamsburg, VA  
KTA-TATOR, INC. / Pittsburgh, PA  
LIBERTY MUTUAL RESEARCH CENTER / Hopkinton, MA  
MCKNIGHT, DR. MARY / Gaithersburg, MD  
MORSE, MARK P. / Springfield, PA  
NAS / Norfolk, VA  
NAVAIR / Code 5163, Lakehurst, NJ  
NAVAIRSYSCOM / Code 5511B, Washington, DC  
NAVFACENCOM / CO, Alexandria, VA  
NAVFACENCOM / Code 03, Alexandria, VA  
NAVFACENCOM / Code 04A1A, Alexandria, VA  
NAVFACENCOM / Code 04A4B, Alexandria, VA  
NAVFACENCOM / Code 16, Alexandria, VA  
NAVFACENCOM / Code 163, Alexandria, VA  
NAVFACENCOM / Code 18, Alexandria, VA  
NAVFACENCOM / Code DS02, Alexandria, VA  
NAVFACENCOM CHESDIV / CO, Washington, DC  
NAVFACENCOM LANTDIV / CO, Norfolk, VA  
NAVFACENCOM NORTHDIV / Code 102, Philadelphia, PA  
NAVFACENCOM PACDIV / CO, Pearl Harbor, HI  
NAVFACENCOM SOUTHDIV / CO, Charleston, SC  
NAVFACENCOM SOUTHWESTDIV / CO, San Diego, CA  
NAVFACENCOM WESTDIV / CO, San Bruno, CA  
NAVRSHLAB / Code 6123, Washington, DC  
NAVSEA / Code 51412.4, Washington, DC  
NAVSHIP / Code 044B, Philadelphia, PA  
NCBC / Code 1563, Port Hueneme, CA  
OLD-NORTH MANUFACTURING CO., INC / Lenoir, NC  
P.R. GUEVIN ASSOCIATES / Westerville, OH  
PACIFIC SCIENTIFIC / Silver Spring, MD  
PAUL N. GARDNER CO. / Pompano Beach, FL  
PENNSYLVANIA TRANSPORTATION INSTITUTE /  
University Park, PA  
PWC / Commanding Officer, FPO San Francisco  
PWC / Commanding Officer, Oakland, CA  
PWC / Commanding Officer, San Diego, CA  
PWC / Great Lakes, IL  
PWC / Pearl Harbor, HI  
PWC / Pensacola, FL  
PWC / Philippines, FPO San Francisco  
PWC / Yokosuka, FPO Seattle  
SLIP TEST / Lewisburg, PA  
TENNANT COMPANY / Minneapolis, MN  
TNE MEC COMPANY, INC. / North Kansas City, MO

## DISTRIBUTION QUESTIONNAIRE

The Naval Civil Engineering Laboratory is revising its primary distribution lists.

### SUBJECT CATEGORIES

#### 1 SHORE FACILITIES

- 1A Construction methods and materials (including corrosion control, coatings)
- 1B Waterfront structures (maintenance/deterioration control)
- 1C Utilities (including power conditioning)
- 1D Explosives safety
- 1E Aviation Engineering Test Facilities
- 1F Fire prevention and control
- 1G Antenna technology
- 1H Structural analysis and design (including numerical and computer techniques)
- 1J Protective construction (including hardened shelters, shock and vibration studies)
- 1K Soil/rock mechanics
- 1L Airfields and pavements
- 1M Physical security

#### 2 ADVANCED BASE AND AMPHIBIOUS FACILITIES

- 2A Base facilities (including shelters, power generation, water supplies)
- 2B Expedient roads/airfields/bridges
- 2C Over-the-beach operations (including breakwaters, wave forces)
- 2D POL storage, transfer, and distribution
- 2E Polar engineering

#### 3 ENERGY/POWER GENERATION

- 3A Thermal conservation (thermal engineering of buildings, HVAC systems, energy loss measurement, power generation)
- 3B Controls and electrical conservation (electrical systems, energy monitoring and control systems)
- 3C Fuel flexibility (liquid fuels, coal utilization, energy from solid waste)

- 3D Alternate energy source (geothermal power, photovoltaic power systems, solar systems, wind systems, energy storage systems)

- 3E Site data and systems integration (energy resource data, integrating energy systems)

- 3F EMCS design

#### 4 ENVIRONMENTAL PROTECTION

- 4A Solid waste management
- 4B Hazardous/toxic materials management
- 4C Waterwaste management and sanitary engineering
- 4D Oil pollution removal and recovery
- 4E Air pollution
- 4F Noise abatement

#### 5 OCEAN ENGINEERING

- 5A Seafloor soils and foundations
- 5B Seafloor construction systems and operations (including diver and manipulator tools)
- 5C Undersea structures and materials
- 5D Anchors and moorings
- 5E Undersea power systems, electromechanical cables, and connectors
- 5F Pressure vessel facilities
- 5G Physical environment (including site surveying)
- 5H Ocean-based concrete structures
- 5J Hyperbaric chambers
- 5K Undersea cable dynamics

#### ARMY FEAP

- BDG Shore Facilities
- NRG Energy
- ENV Environmental/Natural Responses
- MGT Management
- PRR Pavements/Railroads

### TYPES OF DOCUMENTS

**D** = Techdata Sheets; **R** = Technical Reports and Technical Notes; **G** = NCEL Guides and Abstracts; **I** = Index to TDS; **U** = User Guides;  None - remove my name

## INSTRUCTIONS

The Naval Civil Engineering Laboratory has revised its primary distribution lists. To help us verify our records and update our data base, please do the following:

- Add - circle number on list
- Remove my name from all your lists - check box on list.
- Change my address - line out incorrect line and write in correction  
**(DO NOT REMOVE LABEL).**
- Number of copies should be entered after the title of the subject categories you select.
- Are we sending you the correct type of document? If not, circle the type(s) of document(s) you want to receive listed on the back of this card.

Fold on line, staple, and drop in mail.

### DEPARTMENT OF THE NAVY

Naval Civil Engineering Laboratory  
Port Hueneme, CA 93043-5003

Official Business  
Penalty for Private Use, \$300



### BUSINESS REPLY CARD

FIRST CLASS PERMIT NO. 12503 WASH D.C.

POSTAGE WILL BE PAID BY ADDRESSEE

NO POSTAGE  
NECESSARY  
IF MAILED  
IN THE  
UNITED STATES



**Commanding Officer  
Code L34  
Naval Civil Engineering Laboratory  
Port Hueneme, CA 93043-5003**

# NCEL DOCUMENT EVALUATION

You are number one with us; how do we rate with you?

We at NCEL want to provide you our customer the best possible reports but we need your help. Therefore, I ask you to please take the time from your busy schedule to fill out this questionnaire. Your response will assist us in providing the best reports possible for our users. I wish to thank you in advance for your assistance. I assure you that the information you provide will help us to be more responsive to your future needs.



R. N. STORER, Ph.D, P.E.  
Technical Director

DOCUMENT NO. \_\_\_\_\_ TITLE OF DOCUMENT: \_\_\_\_\_  
 \_\_\_\_\_

Date: \_\_\_\_\_ Respondent Organization : \_\_\_\_\_

Name: \_\_\_\_\_ Activity Code: \_\_\_\_\_  
 Phone: \_\_\_\_\_ Grade/Rank: \_\_\_\_\_

Category (please check):

Sponsor \_\_\_\_\_ User \_\_\_\_\_ Proponent \_\_\_\_\_ Other (Specify) \_\_\_\_\_

Please answer on your behalf only; not on your organization's. Please check (use an X) only the block that most closely describes your attitude or feeling toward that statement:

SA Strongly Agree    A Agree    O Neutral    D Disagree    SD Strongly Disagree

	SA	A	N	D	SD		SA	A	N	D	SD
1. The technical quality of the report is comparable to most of my other sources of technical information.	( )	( )	( )	( )	( )	6. The conclusions and recommendations are clear and directly supported by the contents of the report.	( )	( )	( )	( )	( )
2. The report will make significant improvements in the cost and or performance of my operation.	( )	( )	( )	( )	( )	7. The graphics, tables, and photographs are well done.	( )	( )	( )	( )	( )
3. The report acknowledges related work accomplished by others.	( )	( )	( )	( )	( )	Do you wish to continue getting NCEL reports? <input type="checkbox"/> YES <input type="checkbox"/> NO					
4. The report is well formatted.	( )	( )	( )	( )	( )	Please add any comments (e.g., in what ways can we improve the quality of our reports?) on the back of this form.					
5. The report is clearly written.	( )	( )	( )	( )	( )						

Comments:

*Please fold on line and staple*

**DEPARTMENT OF THE NAVY**  
**Naval Civil Engineering Laboratory**  
**Port Hueneme, CA 93043-5003**

**Official Business**  
**Penalty for Private Use \$300**



Code L03B  
NAVAL CIVIL ENGINEERING LABORATORY  
PORT HUENEME, CA 93043-5003