

2

AD-A237 353



USACERL Special Report M-91/20
May 1991



**US Army Corps
of Engineers**
Construction Engineering
Research Laboratory

Use and Upgrade of the USACERL Biaxial Shock Test Machine: Workshop Summary

by
John R. Hayes, Jr.
James B. Gambill
James Wilcoski
Pamalee A. Brady
Ghassan Al-Chaar

This report summarizes a workshop at the U.S. Army Construction Engineering Research Laboratory (USACERL) on 26 and 27 July 1990. The workshop was an assembly of Government engineers, and university and private industry researchers. It covered the use and potential upgrade of the USACERL Biaxial Shock Test Machine (BSTM) as well as the use of shake tables in general. Workshop participants discussed the BSTM's capabilities, its applicability to perform seismic engineering and in-structure shock research, strategies to use it to support non-Department of Defense agencies, and potential upgrade configurations for it. The consensus of all workshop participants was that the BSTM is a valuable, but underutilized, national research resource, and that it should be used more extensively to perform research. The participants also agreed that upgraded capabilities would further enhance its potential and national value, and they discussed several upgrade schemes.

**DTIC
ELECTE
JUN 28 1991
S B D**

91-03357



Approved for public release; distribution is unlimited.

91 6 24 163

The contents of this report are not to be used for advertising, publication, or promotional purposes. Citation of trade names does not constitute an official indorsement or approval of the use of such commercial products. The findings of this report are not to be construed as an official Department of the Army position, unless so designated by other authorized documents.

DESTROY THIS REPORT WHEN IT IS NO LONGER NEEDED

DO NOT RETURN IT TO THE ORIGINATOR

USER EVALUATION OF REPORT

REFERENCE: USACERL SR M-91/20, *Use and Upgrade of the USACERL Biaxial Shock Test Machine: Workshop Summary*

Please take a few minutes to answer the questions below, tear out this sheet, and return it to USACERL. As user of this report, your customer comments will provide USACERL with information essential for improving future reports.

1. Does this report satisfy a need? (Comment on purpose, related project, or other area of interest for which report will be used.)

2. How, specifically, is the report being used? (Information source, design data or procedure, management procedure, source of ideas, etc.)

3. Has the information in this report led to any quantitative savings as far as manhours/contract dollars saved, operating costs avoided, efficiencies achieved, etc.? If so, please elaborate.

4. What is your evaluation of this report in the following areas?

- a. Presentation: _____
- b. Completeness: _____
- c. Easy to Understand: _____
- d. Easy to Implement: _____
- e. Adequate Reference Material: _____
- f. Relates to Area of Interest: _____
- g. Did the report meet your expectations? _____
- h. Does the report raise unanswered questions? _____

i. General Comments. (Indicate what you think should be changed to make this report and future reports of this type more responsive to your needs, more usable, improve readability, etc.)

5. If you would like to be contacted by the personnel who prepared this report to raise specific questions or discuss the topic, please fill in the following information.

Name: _____

Telephone Number: _____

Organization Address: _____

6. Please mail the completed form to:

Department of the Army
CONSTRUCTION ENGINEERING RESEARCH LABORATORY
ATTN: CECER-IMP
P.O. Box 9005
Champaign, IL 61826-9005

REPORT DOCUMENTATION PAGE

Form Approved
OMB No. 0704-0188

Public reporting burden for this collection of information is estimated to average 1 hour per response, including the time for reviewing instructions, searching existing data sources, gathering and maintaining the data needed, and completing and reviewing the collection of information. Send comments regarding this burden estimate or any other aspect of this collection of information, including suggestions for reducing this burden, to Washington Headquarters Service, Directorate for Information Operations and Reports, 1215 Jefferson Davis Highway, Suite 1204, Arlington, VA 22202-4302, and to the Office of Management and Budget, Paperwork Reduction Project (0704-0188), Washington, DC 20503.

1. AGENCY USE ONLY (Leave Blank)		2. REPORT DATE May 1991	3. REPORT TYPE AND DATES COVERED Final	
4. TITLE AND SUBTITLE Use and Upgrade of the USACERL Biaxial Shock Test Machine: Workshop Summary			5. FUNDING NUMBERS	
6. AUTHOR(S) JOHN R. Hayes, Jr., James B. Gambill, James Wilcoski, Pamalee A. Brady, and Ghassan Al-Chaar				
7. PERFORMING ORGANIZATION NAME(S) AND ADDRESS(ES) U.S. Army Construction Engineering Research Laboratory (USACERL) PO Box 9005 Champaign, IL 61826-9005			8. PERFORMING ORGANIZATION REPORT NUMBER USACERL SR M-91/20	
9. SPONSORING/MONITORING AGENCY NAME(S) AND ADDRESS(ES)			10. SPONSORING/MONITORING AGENCY REPORT NUMBER	
11. SUPPLEMENTARY NOTES Copies are available from the National Technical Information Service, 5285 Port Royal Road, Springfield, VA 22161.				
12a. DISTRIBUTION/AVAILABILITY STATEMENT Approved for public release; distribution is unlimited.			12b. DISTRIBUTION CODE	
13. ABSTRACT (Maximum 200 words) This report summarizes a workshop at the U.S. Army Construction Engineering Research Laboratory (USACERL) on 26 and 27 July 1990. The workshop was an assembly of Government engineers, and university and private industry researchers. It covered the use and potential upgrade of the USACERL Biaxial Shock Test Machine (BSTM) as well as the use of shake tables in general. Workshop participants discussed the BSTM's capabilities, its applicability to perform seismic engineering and in-structure shock research, strategies to use it to support non-Department of Defense agencies, and potential upgrade configurations for it. The consensus of all workshop participants was that the BSTM is a valuable, but underutilized, national research resource, and that it should be used more extensively to perform research. The participants also agreed that upgraded capabilities would further enhance its potential and national value, and they discussed several upgrade schemes.				
14. SUBJECT TERMS USACERL Biaxial Shock Test Machine workshops			15. NUMBER OF PAGES 72	
			16. PRICE CODE	
17. SECURITY CLASSIFICATION OF REPORT Unclassified	18. SECURITY CLASSIFICATION OF THIS PAGE Unclassified	19. SECURITY CLASSIFICATION OF ABSTRACT Unclassified	20. LIMITATION OF ABSTRACT SAR	

FOREWORD

The workshop summarized in this report was one of several activities intended to focus U.S. Army Corps of Engineers (USACE) planning for use of the U.S. Army Construction Engineering Research Laboratory (USACERL) Biaxial Shock Test Machine (BSTM).

The work supporting this workshop was performed by the USACERL Engineering and Materials (EM) Division. Appendix E was provided by Dr. Ian Buckle, Deputy Director of the National Center for Earthquake Engineering Research, State University of New York at Buffalo. Appendix F was provided by Dr. Steve Mahin, University of California at Berkeley. Appendix G was provided by Dr. Daniel D. Kana, Southwest Research Institute, San Antonio, TX. Dr. Paul Howdyshell is Chief of EM. The USACERL technical editor was Gordon L. Cohen, Information Management Office.

USACERL extends its appreciation to all workshop participants, who donated their time for the workshop. Special appreciation is expressed to Dr. William J. Hall, Professor and Head of the University of Illinois Department of Civil Engineering, for chairing the workshop.

COL Everett R. Thomas is Commander and Director of USACERL, and Dr. L.R. Shaffer is Technical Director.

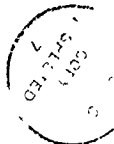

Accession For	
NTIS GRA&I	<input checked="" type="checkbox"/>
DTIC TAB	<input type="checkbox"/>
Unannounced	<input type="checkbox"/>
Justification	
By	
Distribution/	
Availability Codes	
Dist.	Avail and/or Special
A-1	

CONTENTS

	Page
SF298	1
FOREWORD	2
LIST OF FIGURES AND TABLES	4
1 INTRODUCTION	7
Background	
Objective	
Approach	
Scope	
2 SHAKE TABLE APPLICATIONS AND CAPABILITIES	9
General Applications for Shake Table Facilities	
Overview of Major Shake Table Facilities	
The USACERL BSTM	
3 BSTM USE FOR CIVIL ENGINEERING RESEARCH	12
Seismic Engineering	
In-Structure Shock	
4 BSTM UPGRADE AND FUTURE USACERL STRATEGIES	17
BSTM Upgrade	
Future USACERL Strategies	
5 SUMMARY	20
Current BSTM Capabilities	
Panelists' Recommendations	
METRIC CONVERSION FACTORS	21
APPENDIX A: PANEL MEMBERS	22
APPENDIX B: WORKSHOP AGENDA	25
APPENDIX C: SUMMARY OF MAJOR U.S. BIAXIAL SHAKE TABLE CAPABILITIES	26
APPENDIX D: SPECIFICATIONS FOR MAJOR SHAKE TABLE FACILITIES WORLDWIDE	27
APPENDIX E: STATE UNIVERSITY OF NEW YORK AT BUFFALO SEISMIC SIMULATOR	32
APPENDIX F: UNIVERSITY OF CALIFORNIA AT BERKELEY EARTHQUAKE ENGINEERING RESEARCH CENTER	39
APPENDIX G: SOUTHWEST RESEARCH INSTITUTE SHAKE TABLE DESCRIPTION	42
APPENDIX H: USACERL BIAXIAL SHOCK TEST MACHINE	43
APPENDIX I: IN-STRUCTURE SHOCK FIELD-TEST DATA	48
APPENDIX J: POST-WORKSHOP INPUTS	66
ABBREVIATIONS	69
DISTRIBUTION	

FIGURES

Number		Page
C1	Basic horizontal motion capabilities	26
E1	Degrees of freedom controlled	32
E2	Perspective view of shake table and foundation	33
E3	Section in the foundation block	34
E4	Structural components of shake table	35
E5	Limits of harmonic horizontal motion	36
E6	Limits of harmonic vertical motion	37
E7	Simplified three-variable control loop	38
H1	USACERL BSTM horizontal performance	46
H2	USACERL BSTM vertical performance	47
I1	Shock spectra—subsurface detonation, Gage AFX-04, Event 13 (no payload)	49
I2	Shock spectra—subsurface detonation, Gage AFX-04, Event 13 (12,000 lb. payload)	50
I3	Shock spectra—subsurface detonation, Gage AFY-04, Event 13	51
I4	Shock spectra—aboveground detonation, Gage AFY-26, Event 10.	52
I5	Shock spectra—aboveground detonation, Gage AFY-11, Event 02	53
I6	Horizontal in-structure shock spectra	54
I7	L-shaped structure response spectra	55
I8	GLCM structure, Test 1	56
I9	GLCM structure, Test 2	57
I10	GLCM structure, Test 7b—predicted load	58
I11	GLCM structure, Test 7b—measured load	59
I12	L-shaped structure load, Case 1	60
I13	L-shaped structure load, Case 2	61

FIGURES (Cont'd)

Number		Page
I14	L-shaped structure load, Case 4	62
I15	Comparison of the SRS frequency content of different shock environments	63
I16	Development of fragility spectra for equipment, Category B	64
I17	Development of fragility spectra for equipment, Category A	65

TABLES

D1	Specifications for Major Shake Table Systems; Partial List by Date On Line, 1968-1989	28
F1	EERC Shake Table Specifications	40

USE AND UPGRADE OF THE USACERL BIAXIAL SHOCK TEST MACHINE: WORKSHOP SUMMARY

1 INTRODUCTION

Background

The Biaxial Shock Test Machine (BSTM) was designed for the U.S. Army Construction Engineering Research Laboratory (USACERL) by MTS Corp. and installed in 1971. The BSTM was devised to perform shock tolerance testing of equipment intended for use in the SAFEGUARD Anti-Ballistic Missile system. After extensive use in that program, the BSTM entered a long period of steady, but limited, use to support a variety of research related to in-structure shock, seismic engineering, and in-service dynamic loads. Little of this research has been supported by U.S. Army Corps of Engineers (USACE) sustaining research, development, test, and evaluation (RDTE) funding; rather, funding has come from reimbursable projects from various Department of Defense (DOD) and allied agencies, and, to a lesser extent, from private industry and academia.

In the mid-1980s, national attention focused several times on the need for medium and large earthquake simulation "shake tables." The United States has no large shake tables, as defined by the international structural engineering community, and only a small number of medium ones. The USACERL BSTM is generally thought of as a medium-class table. University of Illinois seismic engineering researchers and USACERL personnel recently initiated discussions about the use of the BSTM for non-DOD seismic engineering research and the possible upgrading of the BSTM from its present biaxial configuration into a triaxial "earthquake simulation system."

In 1988, USACERL applied for DOD funding for upgrading the BSTM to include a triaxial motion capability while retaining its unique biaxial capabilities. USACERL sought this funding under the auspices of the Office of the Secretary of Defense Productivity Improvement Fund (OSD-PIF) program. Headquarters USACE (HQUSACE) asked USACERL to validate the need for the upgrade. The requested validation was to include both the technical research requirement for an upgrade and an indication of potential project-level funding sources for performing research.

In March 1990, the USACERL Engineering and Materials (EM) Division began planning a workshop that would assemble a panel of experts from Federal agencies, universities, and private industry to discuss key issues related to BSTM use and possible upgrades. Panel members for the workshop are listed in Appendix A. The workshop was held at USACERL on 26 and 27 July 1990.

Objective

The objective of this workshop was to solicit and obtain guidance from the panel of experts in several key areas:

1. The current state of the art in technologies and applications for medium and large shake tables

2. Applicability of BSTM to in-structure shock research
3. Applicability of BSTM to seismic engineering research
4. Desirable capabilities of an upgraded BSTM
5. Potential initiatives to develop cooperative research programs with other organizations and increase BSTM use.

Approach

The workshop was divided into a number of open panel discussion sessions (see Appendix B). Several sessions included both formal presentations and open discussions. Dr. William J. Hall, Professor and Head, Civil Engineering Department, University of Illinois, chaired the workshop. He was assisted by members of the USACERL Engineering and Materials (EM) Division, Structural Engineering and Physical Security (SEPS) Team.

Scope

The results of the workshop summarized in this report serve as guidance for USACERL but do not in themselves serve as specific direction for USACERL to follow. The concepts presented herein are not necessarily endorsed by USACE or all workshop attendees. However, the authors have attempted to represent all views stated at the workshop, and all attendees have had an opportunity to review a draft of the report before its publication.

2 SHAKE TABLE APPLICATIONS AND CAPABILITIES

General Applications for Shake Table Facilities

Dr. Hall led a general discussion of the uses for shake tables and their existence in the United States. Tables are typically applied to three general categories of research: shock loads on structures and equipment, vibratory effects on equipment, and seismic motion effects on structures and equipment. The desired application heavily influences the performance characteristics of a table, including peak velocities and accelerations, motion frequency ranges, and peak displacement (stroke) capabilities.

In addition to the uses listed above, shake tables have a wide range of other uses, including pilot program studies, production research programs, proof testing, shock isolation studies for both structural systems and their internal components (including equipment), instrumentation development, vibration testing, transmissibility studies, ground-motion-to-structure interaction studies, comparative modeling, deformation damage and failure studies, theory development, and education.

Overview of Major Shake Table Facilities

There are currently four medium-sized public-sector shake tables in the United States: a uniaxial table at the University of Illinois at Urbana-Champaign (UIUC), and biaxial tables at the University of California (UC) at Berkeley, the State University of New York at Buffalo, and the USACERL BSTM. A graph showing the capabilities of the biaxial tables can be found in Appendix C. A variety of other government shock and vibration platforms exist, primarily for research outside of Civil engineering. A number of commercial tables also exist (e.g., Wyle Labs, Oak Ridge [Tennessee] National Laboratory, Southwest Research Institute, San Antonio, Texas), but they tend to be smaller than those mentioned above.

In contrast to the relatively few medium shake table facilities and total lack of large facilities in the United States, Japan has developed a substantial number of medium and large tables, and is the world leader in developing shake tables for seismic engineering applications. Several European countries, South Korea, Mexico, and the Peoples Republic of China have major facilities as well. Appendix D presents a listing of major shake table facilities and gives a general evaluation of their capabilities. The reader should use the list for general information only; the data are not absolute or all-inclusive. For example, the "Maximum Specimen Weight" usually indicates maximum weight for peak rated performance (e.g., high frequency acceleration and small displacement), but most tables can probably support higher payloads with reduced displacement capabilities. The USACERL BSTM has tested 30-ton* specimens (versus the 6 tons listed) satisfactorily for seismic motion studies. The list in Appendix D also points out that the United States has fallen well behind Japan, South Korea, and the European countries in triaxial shake table capabilities: the United States has none. Appendix E presents an overview of the shake table at the State University of New York (SUNY) at Buffalo. This table now operates under the auspices of the National Center for Earthquake Engineering Research (NCEER), an initiative cosponsored by the National Science Foundation (NSF) and the State of New York. Appendix F presents an overview of the shake table at the University of California at Berkeley. This table is being upgraded to incorporate triaxial motion

*This report uses U.S. standard units of measure. A table of metric conversion factors may be found on page 21.

capabilities, and should be the first U.S. facility to have such capabilities. Information about the private-sector shake table at Southwest Research Institute is presented in Appendix G for comparison with the public-sector facilities noted above.

The USACERL BSTM

The BSTM was constructed in 1970-1971 to support the SAFEGUARD antiballistic missile system development program. Its original primary use was to test system component vulnerabilities to nuclear weapons-induced ground shocks. Even today, the military community makes extensive use of the SAFEGUARD data. Its original purpose dictated its unique operating characteristics of high frequency, high velocity and high acceleration with relatively large payloads. The authors and workshop panelists are unaware of another facility like it in the free world.

The BSTM platform measures 12 by 12 ft. It is an aluminum composite structure, rather than the more typical reinforced concrete platforms used in seismic tables, giving it the light weight and stiffness needed to accommodate high frequency motions (0-600 Hz). Its rated payload for peak performance is 12,000 lb, but the term "rated payload" must be qualified. The BSTM has simulated seismic motions for test articles weighing 60,000 lb and has also reached higher than peak rated accelerations for payloads weighing less than 12,000 lb. The bare table weighs 12,000 lb, so peak accelerations of the bare table are twice those of its rated performance.

As its name implies, the BSTM has motion capability associated with its vertical axis and one horizontal axis. This arrangement results in five degrees of freedom in the system: translation in the vertical and single horizontal axis directions; and roll, pitch, and yaw. The BSTM control system permits simultaneous vertical and horizontal translations and can be used to simulate earthquake motion, transient shocks, random vibrations, and log sweep/resonant searches.

Peak-to-peak displacement capabilities are 2.75 in. vertical and 5.5 in. horizontal. Maximum vertical acceleration is 30 g and maximum horizontal acceleration is 20 g. Maximum velocity is 30 in./sec both horizontally and vertically. Vertical force actuators can develop 810,000 lb thrust and horizontal actuators can develop 450,000 lb thrust. Appendix H presents log-log plots of the horizontal and vertical limits of BSTM motion capabilities and descriptions of the BSTM's major features.

The BSTM has a 20-year history of successful testing, representing a wide variety of simulation environments. Major testing programs include:

1. Developing shock-resistant test equipment configurations for high explosives tests by Field Command, Defense Nuclear Agency (FCDNA). USACERL designed and tested a blast-protected, shock-isolated instrumentation bunker system for above-ground testing at the White Sands Missile Range and a computer shock isolation platform for data acquisition systems at the Nevada underground test site. USACERL also shock tested fiber optics data system components for the Nevada test site and determined the source of intermittent electrical faults that had been interrupting data acquisition. This research resulted in more survivable and functional instrumentation and controls for FCDNA.

2. Analyzing effects of ground motion-induced in-structure shock in Airborne Warning and Control System (AWACS) command centers designed by the U.S. Air Force for construction in Saudi Arabia. Most of this work centered on raised computer floor systems; the experiments showed that existing floor systems could withstand anticipated motions. Such a definitive determination would not

have been possible through numerical analyses alone; this afforded cost savings through allowing less conservative design.

3. Performing life-cycle vulnerability analyses on naval gun mounts. The work was actually performed for FMC Corp., but its results were incorporated in U.S. Navy weapons systems. The research uncovered a serious design weakness that caused severe resonance and subsequent loss of gun barrel control. FMC was able to correct the problem before government procurement occurred.

4. Performing satellite communication ground station tests involving service life vibrations for RCA Corp. These systems have now been procured and fielded by the U.S. Army. The tests resulted in system refinements that successfully qualified the equipment for Army procurement. Before that time, such testing had to be performed on individual system components, with the subsequent individual test results being superimposed numerically to portray the total system response.

5. Performing seismic testing of structural systems. Scaled-model seismic tests have included nuclear power plant structures for Los Alamos National Laboratories, multistory framed structures for the University of Illinois, and earth retaining walls for Purdue University. These tests all provided accurate experimental modeling for use in refining analytical models.

6. Performing seismic qualification tests of electronic equipment for nuclear power plants. This testing has been performed on a cost-reimbursable basis for private-sector companies.

7. Simulating artillery acoustic environments for use in studying high energy, low frequency noise effects on civilian structures. By stretching a heavy membrane over its platform, researchers can use the BSTM to develop noise within the range of its frequency response characteristics. These tests, which supported USACERL Environmental (EN) Division research, resulted in improved field testing procedures for EN personnel.

3 BSTM USE FOR CIVIL ENGINEERING RESEARCH

There are two primary areas of potential application for the BSTM in civil engineering research: seismic engineering and military in-structure shock. Workshop attendees generally had expertise in one or both of these fields, so two simultaneous panel discussions were conducted to identify major technical issues in those areas.

Seismic Engineering

Dr. Richard Wright, National Institute of Standards and Technology (NIST), chaired the seismic engineering discussions. Except for Dr. Hall, all university researchers at the workshop attended this session, as did all Federal non-DOD laboratory representatives.

Initial discussions centered on defining the general uses of shake tables in seismic engineering research, with emphasis on the specific applicability of the BSTM. Shake tables are used to address such research topics as structural detailing of building components, structural framework behavior, and the behavior of large structural systems (e.g., dams). Few full-scale structural prototype tests are run on shake tables because of size and weight limitations. More typically, replica tests are performed on scaled structural system models or scaled components. While not so much a pure structural engineering topic, another area of major interest in the seismic engineering arena is seismic qualification testing of electrical and mechanical equipment for nuclear power plant applications and other critical facility systems. There are well established dynamic test requirements for qualifying such equipment.

The BSTM has both strengths and limitations for performing seismic engineering research. Its two primary strengths are high frequency capability and high driving force, both of which are the largest known for current shake table capabilities in the United States. The high frequency is particularly well suited for motion-time history and response spectra modeling. It is also excellent for scaled modeling of structural systems since most scaling relationships require that frequencies of motions vary inversely with geometric scales (e.g., a half-scale model would require a doubling of motion frequency). The high horizontal frequency component capability also permits shock testing of lightweight components (discussed in more detail later in this report). The high driving force permits seismic testing of much heavier payloads, with correspondingly lower frequencies. The high payload capacity also allows the testing of models with lateral dimensions larger than the table platform through the use of cantilevered platforms of appropriate sizes.

An interesting theme in this discussion was the idea that the BSTM is potentially an important asset for the midwestern U.S. seismic research community—principally the region's universities. The primary reason for this is simply the BSTM's closer location to Midwest research institutions than the other major shake tables in California and New York. From a technical standpoint, however, there is limited evidence that eastern U.S. earthquakes, when compared to western U.S. earthquakes, have somewhat higher ground motion frequency contents for events of equal magnitude and epicentral distance. This evidence is not strong, and most anticipated eastern ground motion frequencies are within the performance envelopes of the BSTM.

The BSTM has two primary limitations related to seismic research. First, its peak-to-peak displacement (5.5 in. horizontal), or stroke, limits its ability to replicate full-scale ground motions and associated peak velocities at low frequencies. In spite of this limitation, however, many valuable tests can

be performed at less than full scale, with appropriately scaled ground motions. In addition, many of the larger displacements in seismic events tend to occur at frequencies low enough to permit their being filtered out of full-scale shake table motions without serious effect on test results (because resulting structural motions are rigid-body modes). With increased interest in post-elastic behavior and base isolation, however, low-frequency/high-velocity motions have assumed more significant roles. Therefore, filtering and/or scaled modeling are not always viable solutions. While many tests can be conducted on the BSTM, motion parameters must be studied carefully and on a case-by-case basis.

The second important limitation of the BSTM, common to all current major U.S. tables, is its lack of triaxial performance capability. This limits its ability to test post-elastic structural behavior and torsional performance of structural systems, although much valuable information can still be gained through added biaxial testing. (As previously noted, UC Berkeley is pursuing an upgrade from biaxial to triaxial capability.)

One purely technical seismic research issue discussed was the BSTM's stroke, which is viewed as its most immediate seismic research limitation. Longer stroke is a desirable goal for any upgrade effort, but the conferees cautioned that USACERL should ensure that the current high frequency ability is not lost in any upgrade. Since, in a given mechanical system of this kind, stroke may be viewed as inversely proportional to frequency, special attention must be paid to any actuator upgrades that increase stroke. Retention of the BSTM's high frequency motion capability should be a priority.

The remaining seismic panel discussions centered on procedural issues related to the BSTM's use in seismic research. Seismic research is not solely a DOD concern. With the limited number of public-sector shake tables in the United States, many researchers could benefit from access to shake tables. Use of the BSTM is now quite limited, with a utilization rate estimated at 10 to 15 percent of availability. This is in contrast to the SUNY Buffalo and UC Berkeley tables, which are said to be heavily used. Group consensus was that the BSTM should be a part of the national infrastructure for seismic research. While this could start with BSTM's use by Midwestern institutions as a regional resource, it should extend nationally. Dr. Ian Buckle, of the National Center for Earthquake Engineering Research (NCEER), SUNY Buffalo, indicated a desire to direct potential shake table researchers to the BSTM, as the SUNY Buffalo table is heavily used already.

The current low BSTM utilization rate was viewed as a major problem that requires change, especially to support any proposed upgrade efforts. Put simply, if the BSTM does not now attract users frequently, upgrade funding seems to be a questionable expenditure. Research community perceptions that must be addressed, whether they are right or wrong, include:

- The BSTM is a "shock" table not well suited for seismic research. *Panelists agreed that this perception is incorrect, and USACERL must communicate this to the community of potential users.*
- USACERL is a closed, secret Government laboratory not generally open to seismic research. *USACERL is not closed to the public, but this perception must be addressed.*
- The USACERL staff does not have the strong technical background needed to guide and perform seismic research. *The USACERL staff is comparable to those of other Government laboratories, but does not compare to major university staffs. Both the perception and the actual staffing should be addressed.*
- There has been little published in open literature on BSTM research. *This has been true and must be changed.*

- There is no solid long-range research plan for the BSTM. *This has been an historical problem due to a lack of long-range funding within DOD circles.*

The panelists recommended that USACERL and the University of Illinois form a closer, more unified working relationship to guide and use the BSTM. The university could provide both the added technical expertise and the open access to non-DOD institutions that are needed to improve BSTM utilization and provide solid justification for upgrades. Such a cooperative venture could easily expand to include participation by other research institutions, possibly in the form of a Midwest seismic research consortium.

In closing the panel discussions, Dr. Wright asked the panelists to vote in principle for or against a triaxial upgrade initiative for the BSTM, with no extensive consideration of fiscal constraints. Four of the non-USACERL panelists voted against the upgrade, while the other eight voted for it.

In-Structure Shock

Dr. Michael Katona, Headquarters, Air Force Engineering and Services Center, chaired the in-structure shock discussions. The BSTM was originally built to develop a database of equipment vulnerabilities to nuclear weapons-induced ground shocks for the old SAFEGUARD antiballistic missile system, and use of the BSTM for such studies has continued. However, many questions have been raised about the BSTM's use in such testing. Many have thought that the extremely high frequencies and peak accelerations seen in structural motions in high explosives tests exceed the BSTM's performance envelope by so much that the BSTM cannot be used to develop significant research information for in-structure shock mitigation. With this concern in mind, Dr. Katona structured the discussions to cover four main topics: simulation of in-structure shock, equipment shock tolerance, scaling-law issues, and upgrade to triaxial motion capabilities. The group used several handouts to guide its discussions, which are reproduced in Appendix I.

The discussion began by covering the ability of the BSTM to simulate the motion histories of facilities subjected to weapons effects, especially the high frequencies and accelerations associated with conventional weapons detonations very near protective structures. This simulation is not primarily focused on studying structural element behavior, but is used to study equipment response and shock-isolation system behavior. Modern weapons effect tests on structures frequently show high peak accelerations (e.g., 1000 g) and high motion frequencies (e.g., 1000 Hz) of floor and wall members following weapons detonations. Do these motion characteristics, which clearly exceed the BSTM's performance limits, negate the use of the BSTM for equipment vulnerability and shock isolation tests? Group consensus, lead by Dr. George Y. Baladi, Air Force Weapons Laboratory, and Dr. Sam A. Kiger, West Virginia University, was that the inability of the BSTM to reproduce all extremes in the test data is not a limitation that rules out BSTM use. In ongoing Weapons Laboratory research, equipment failures are seen to be more likely at the lower frequencies of 10 to 60 Hz—well within the BSTM's capabilities. Dr. Kiger added that, while energy is present in 1000 Hz motions, displacements are so small that installed equipment normally does not respond. Dr. Katona suggested that one evaluation test for the BSTM would be to analyze the DNA-sponsored CONWEB series test data developed by the U.S. Army Waterways Experiment Station (USAWES), concentrating on the recorded structural responses and analyzing any observed BSTM shortcomings in its ability to reproduce the field test data.

Often, equipment fragility testing has focused on ability to withstand peak accelerations as the measure of merit for equipment. Peak acceleration tolerances of 100 g have not been uncommon requirements. Such shocks have been attained by smaller tables because individual equipment items are often small and, therefore, lightweight. In other instances, equipment has been subjected to steady-state sinusoidal tests to establish vulnerabilities. The group consensus was that these tests are probably overconservative. Testing procedures should also incorporate pulse durations and frequency contents. Furthermore, the group suggested the BSTM should be used to develop meaningful equipment fragility testing procedures, and that USACERL should take the lead in promoting more reasonable equipment design criteria. Fragility curves could be developed by driving the BSTM with random signals that are consistent with design spectra. Mr. Mike Riley, Underwater Explosions Research Division, U.S. Navy David Taylor Research Center, also discussed ship shock-related equipment testing. For the Navy's larger ships, many of the higher frequency and higher acceleration motions are filtered out by the ship structures, and the BSTM may have potential application in simulating large displacement, shock-induced vibrations observed during ship shock trials.

Dr. Katona, Dr. Kiger, and Dr. Hall then briefly discussed the combination of high frequency and high acceleration motion inputs for equipment fragility testing. Since these motions are usually accompanied by very small displacements, their effects on equipment would be limited. Also, many equipment items are mounted in racks that effectively filter out many of these high accelerations.

Discussions of scaling law problems were limited. Since the primary in-structure shock research application is for equipment, most tests of this kind would be performed at fullscale. For reduced-scale structural tests, the major concern was about strain rate effects in shock isolation and other structural systems.

The panel then discussed potential upgrade schemes for the BSTM, including the already proposed triaxial upgrade. The group agreed in principle that upgrading to a triaxial capability is valuable. A triaxial capability would permit studies of asymmetric structural behavior, structural responses in orthogonal directions, coupling of horizontal motion components, and nonlinear structural behavior. With biaxial tests, nonlinear motions are especially difficult, because superposition of orthogonal motions from two separate tests to simulate a triaxial response is not straightforward. There can even be response frequency shifts because of coupling effects. Therefore, having a triaxial motion ability is most important. (Authors' note: it is important for the reader to note that current upgrade plans do not include having the same high acceleration capability in the third axis of triaxial motion). In developing upgrade plans, many panelists felt USACERL should consider staying with a biaxial capability, but developing higher peak acceleration capabilities. In a straw vote, four panelists preferred upgrading the BSTM to a triaxial capability, while five voted for achieving higher biaxial accelerations without a triaxial capability. This vote was predicated upon the group's concentration on in-structure shock testing and did not consider seismic research.

The panelists then discussed two possible hybrid upgrade schemes that merit some consideration. First, if the BSTM's current hydraulic capability could be increased, perhaps both a triaxial seismic capability and a higher acceleration biaxial capability could be developed. Second, for equipment testing, perhaps a separate table could be mounted on the BSTM that, with proper control, could create the high acceleration environment desired by the panelists.

There were several closing discussions. Dr. Hall indicated that in-structure shock research was largely experimental from the 1940s to the mid-1960s, when a large percentage of the research shifted to analytical bases. With the advent of high-strength and energy-absorbing materials, and stiffer, smaller

equipment items, there is a renewed need for experimental research. A shake table, where applicable, offers the advantage of repeatability over field (e.g., explosive) tests. Dr. Hall also mentioned the need to test shock isolation systems and to develop public-sector data on equipment fragility that is not subject to the same dissemination restrictions that exist for private industry testing. He also said that the uniaxial shake table at the University of Illinois would probably not be upgraded in the near future because of its close proximity to the BSTM.

Dr. Katona offered the final remarks by mentioning several other areas of potential BSTM application: cargo shipping tests, transportation environment testing, vehicle system testing, soil-structure interaction research, geotechnical boundary condition research, hydrodynamics tests, and research on fluid behavior in tanks and reservoirs.

4 BSTM UPGRADE AND FUTURE USACERL STRATEGIES

In summary sessions, panelists reviewed specific details of the proposed BSTM upgrade and discussed strategies USACERL should pursue to promote support for BSTM activities.

BSTM Upgrade

Mr. John R. Hayes, Jr., presented an overview of USACERL's efforts to upgrade the BSTM to a triaxial motion capability, and Mr. Frank Conati, MTS Corp., added insights related to potential upgrade measures. To summarize briefly, the University of Illinois, lead by Dr. Mete Sozen, and USACERL began exploring possible upgrade schemes for the BSTM in the mid-1980s. The concept then envisioned involved creating an earthquake simulation system (ESS) from the BSTM. The upgrade would have left all existing biaxial capabilities of the BSTM intact and would have added a triaxial motion system with peak horizontal accelerations of 1.7 g in both orthogonal horizontal axes. The system could, in effect, be "switched" from biaxial to triaxial capability, and vice versa. The ESS would have included all mechanical and structural modifications required to accommodate the added controlled motion, and it would have included updated electronics for controls and instrumentation.

In early 1988, USACERL initiated a proposal for funding an upgrade of the BSTM. The proposal, for OSD-PIF funds, was for a triaxial upgrade that exceeded the capabilities of upgrades proposed earlier. As with the ESS concept, the BSTM's existing biaxial capabilities would be maintained. For triaxial motion, this upgrade would have provided a peak acceleration of 3.4 g in each orthogonal horizontal direction. This was felt to be the peak acceleration attainable in a triaxial configuration without requiring costly modification to the existing hydraulic system. With all anticipated electronic, mechanical, and structural modifications to accommodate this upgrade, but without a detailed analysis, USACERL estimated the cost of this upgrade at about \$7 million to \$8 million. This proposal has not been funded by the Department of Defense; a final decision has been withheld pending USACERL's providing added cost-benefit analyses to Army officials. (Authors' note: the cost estimate is probably high because of the many unknowns involved. More detailed design analysis is likely to lower the cost estimate.)

In both of the above-mentioned proposals, the existing stroke capabilities of the BSTM would be maintained. In recognition of the concern exhibited by the seismic engineering panelists over the BSTM's currently limited stroke, Mr. Conati expressed the opinion that a potential third axis (lateral horizontal) displacement of approximately 10 in. was attainable with typical earthquake performance. In the normal BSTM shock operating mode, the third axis would provide lateral motion restraint only. One of the major problems is the small amount of space available for absorbing the reaction of the lateral actuator forces. Mr. Conati also discussed strategies for updating the BSTM's electronic control system, a step all panelists considered necessary. Three technology options were discussed: (1) analog, (2) direct digital control, and (3) hybrid control. Mr. Conati felt that a complete direct digital control system was beyond the capabilities of current technology because of the high frequency response requirements of the BSTM. Analog control could be provided, but it would require more setup time when switching from biaxial shock mode to triaxial earthquake mode, and vice versa. Hybrid control, which combines the response of analog circuits with the appeal of digital setup, has been installed at other research facilities by MTS. Mr. Conati suggested that this approach was the most attractive for the unique requirements of the BSTM and triaxial earthquake simulator.

Future USACERL Strategies

Dr. Hall concluded the workshop by allowing the attendees to voice their observations on the workshop and the future course of action USACERL should pursue. Listed below are the major observations and recommendations:

1. Dr. Wright lead a discussion about developing support for the BSTM. The consensus of the panelists was that non-DOD funding is needed to establish full utilization. Furthermore, it was agreed that USACERL must develop a marketing strategy rather than wait for clients to come to the BSTM. Dr. Wright suggested that USACERL should aim for \$2 million to \$4 million in shake table research annually, and should approach such agencies as state governments and universities to develop cooperative research programs.

2. Dr. L.R. Shaffer (USACERL Technical Director) and Mr. Hayes told the panelists that, contrary to the way many Government laboratories operate, USACERL has relative freedom to work with non-Federal agencies on cooperative research. USACERL can work with other agencies under well established contracting and personnel procedures. More importantly, USACERL can accept funds from non-DOD and non-Federal sources to perform research (on the BSTM, for example) as long as the research does not pose unfair competition to a non-Government organization. Since the BSTM has no equal counterpart in private industry, such research would pose no problems in this regard. In fact, USACERL has already performed BSTM testing for several private-sector clients.

3. Dr. Hall stated that the United States now has a critical need for structural dynamics experimental research, including shake table research. In the seismic arena alone, the advent of base isolation technologies, active and passive damping mechanisms, and very high strength concretes necessitates substantial new testing programs. He also mentioned the lack of U.S. competitiveness with Japan in implementing shake table research, especially in the area of triaxial tables. He also cautioned the panelist that there are conflicting bureaucratic concerns: some are concerned about underutilization of experimental equipment while others question whether our experimental equipment is adequate.

4. Dr. Katona commented that major upgrade initiatives for the BSTM should focus on either the shock environment or the seismic environment, but not try to optimize both. He also said that, considering the likelihood of DOD budget cuts, the real shake table research market will probably lie with the seismic engineering community.

5. Dr. Baladi and Dr. Buckle stated that the BSTM is a world-class research facility that shares U.S. shake table leadership with the UC Berkeley and SUNY Buffalo tables. The hydraulic force capacities of the BSTM exceed those of any other U.S. shake table, and this should serve as a major selling point. Dr. Buckle further stated that, since both of the other major public-sector U.S. tables are near their research use capacities, the BSTM should be coming on line as a national asset. He said USACERL should update the electronic controls and data acquisition systems, and recommended that a 5- to 10-year usage plan be developed.

6. Mr. William H. Gaube, USACE Omaha District, indicated that more specimen preparation space for BSTM test articles is needed. Everyone in attendance agreed.

7. Dr. Cornelius J. Higgins, Applied Research Associates, emphasized the need for the BSTM to be marketed nationally as a national asset. He felt that group consensus indicated that a longer stroke is needed even before triaxial capability. He also stressed the need for more UIUC involvement in

marketing, research, and pursuing upgrade packages. The panelists echoed Dr. Higgins' sentiments and re-emphasized the need to include world-class research expertise, such as that available at the University of Illinois, on the research team. Many panelists were concerned that the USACERL research staff lacks the expertise and reputation required to attract large university research programs.

8. Mr. Gutberlet, HQUSACE, joined Mr. Gaube in emphasizing that future use and upgrade of the BSTM could not simply be an Army initiative. It should at least be tied closely to the University of Illinois. They suggested that the best future for the BSTM might even be for the Corps of Engineers to relinquish the BSTM to the University of Illinois. The Army could then use the BSTM on contract. Mr. Gaube also recommended that an experimental research program using the existing BSTM be in place before an upgrade is considered.

9. Dr. Baladi asked why there is no cooperation between USACERL and USAWES in use of the BSTM. He recommended that the two organizations should explore cooperation in structural and geotechnical research. Dr. Kiger indicated that USAWES experimental programs do not include consideration of BSTM availability because geographical and organizational separations impede such cooperation.

10. Dr. Henry J. Lagorio, National Science Foundation (NSF), indicated that NSF has had funding available for equipment upgrades and seismic research. He said NSF encourages cooperative research among national universities and Government laboratories. NSF has already funded part of the triaxial upgrade initiative at UC Berkeley. NSF will consider supporting research work and equipment upgrades at Government research facilities such as the BSTM, but the support will be conditional on the availability of matching funds by the other Government agencies involved, and on heavy inclusion of university researchers and students.

At the conclusion of the workshop the panelists were invited to furnish any additional comments through followup letters or telephone calls. A summary of these can be found in Appendix J.

5 SUMMARY

Current BSTM Capabilities

The USACERL BSTM is one of the most capable large-payload shake tables in the world. In terms of its ability to produce simultaneous horizontal and vertical motions with high peak accelerations and wide frequency ranges, it is well suited to perform a variety of experimental functions.

The BSTM is widely viewed as the one U.S. shake table most capable of performing in-structure shock-related equipment vulnerability and shock isolation testing. Its large frequency range (0-600 Hz) and high peak acceleration capabilities (20 g horizontal, 30 g vertical) for test articles weighing as much as 12,000 lb suit it well for such research. Panelists unanimously expressed the opinion that USACERL should maintain this capability. They also expressed their desire for an increased peak acceleration capability to permit more detailed study of high peak acceleration motion histories. The general consensus was that the BSTM can be used to study many, but not all, significant in-structure-shock-related issues in its present configuration. Panelists affirmed that the BSTM can serve a valuable role in complementing field explosives testing and analytical research.

The BSTM's title incorporates the term "shock," and it was recognized that this has had a negative effect on the seismic research community's perceptions of the shake table's range of capabilities. Nevertheless, panelists agreed that the BSTM is very well suited for seismic engineering research, especially on scaled models, and should be used nationally to complement the capabilities of the shake tables at UC Berkeley and SUNY Buffalo. Its higher frequency capability is highly applicable to scaled structural modeling. The BSTM's stroke capabilities limit its applicability to perform full-scale modeling, and the majority of the panelists expressed a desire for an increased stroke. However, they noted that full-scale tests are not generally performed on other shake tables, either.

While the BSTM was viewed as a highly capable machine that should be used more in its current configuration, most panelists agreed that USACERL should pursue an eventual upgrade to triaxial motion capability to permit the study of more complex dynamic phenomena.

Panelists' Recommendations

Based on summary statements by workshop panelists, the following recommendations were generally agreed upon:

1. USACERL should pursue a control system upgrade that more fully employs digital electronics than the current control system does. This would provide a more flexible research capability and promote more research throughput.
2. Increased stroke in at least one major horizontal direction should be a key part of any future upgrade. This would permit more full-scale seismic testing.
3. USACERL should continue to pursue triaxial upgrade efforts. (Authors' note: Panelists unanimously endorsed upgraded controls and increased stroke as immediate upgrade needs, regardless of triaxial capability upgrades.)

4. USACERL needs more specimen preparation space to support BSTM productivity.
5. USACERL must develop cooperative relationships with other Federal agencies, state governments, and academia. Appropriate relationships with private industry that generate long-range research programs and support for facility upgrades were also recommended.
6. USACERL should develop a closer technical working relationship in BSTM research with the University of Illinois. The relationship should be mutually beneficial to USACERL and the University through technical interchange and broader facility use.
7. USACERL should develop a national marketing strategy for the BSTM that emphasizes its strengths as a national research resource.

METRIC CONVERSION FACTORS

1 ton	=	907.1848 kg
1 lb	=	0.453 kg
1 in.	=	2.54 cm
1 ft	=	0.3048 m
1 yd	=	0.9144 m
1 gal	=	3.785 l

APPENDIX A: PANEL MEMBERS

I. Workshop Attendees:

Dr. George Y. Baladi
Civil Engineering Research Division
U.S. Air Force Weapons Laboratory

Dr. Ian G. Buckle Deputy Director
National Center for Earthquake Engineering Research
State University of New York, Buffalo

Mr. Frank Conati
MTS Systems Corp.

Mr. William J. Flathau
JAYCOR, Inc.

Dr. Theodore V. Galambos
Department of Civil and Mineral Engineering
University of Minnesota

Mr. William H. Gaube
Protective Design Center
U.S. Army Corps of Engineers, Omaha District

Dr. Phillip L. Gould
Civil Engineering Department
Washington University, St. Louis, MO

Mr. Charles H. Gutberlet, Jr.
Engineering Division, Directorate of Military Programs
Headquarters, U.S. Army Corps of Engineers

Dr. William J. Hall
Department of Civil Engineering
University of Illinois, Urbana-Champaign

Dr. Cornelius J. Higgins
Applied Research Associates, Inc.

Dr. James O. Jirsa
Ferguson Structural Engineering Laboratory
University of Texas, Austin

Mr. Dale Jones
Center for Natural Phenomena Studies
Martin-Marietta Energy Systems

Dr. Daniel D. Kana
Department of Mechanical Sciences
Southwest Research Institute

Dr. Michael G. Katona
Engineering and Services Laboratory
Headquarters, U.S. Air Force Engineering Services Center

Dr. Sam A. Kiger
Department of Civil Engineering
West Virginia University

Dr. Henry J. Lagorio
Division of Biological and Critical Systems
National Science Foundation

Mr. Mike Riley
Applied Mechanics Group
U.S. Navy David Taylor Research Center

Mr. Ralph W. Strom
North Pacific Division
U.S. Army Corps of Engineers

Mr. James Tanouye
South Pacific Division
U.S. Army Corps of Engineers

Dr. James K. Wight
Department of Civil Engineering
University of Michigan, Ann Arbor

Mr. Stan C. Woodson
Structures Laboratory
U.S. Army Waterways Experiment Station

Dr. Richard N. Wright
Center for Building Technology
National Institute of Standards and Technology

II. Invitees Unable to Attend

Mr. Satish Abrol
Headquarters, U.S. Air Force Engineering and Services

Mr. John Ferrito
U.S. Navy Civil Engineering Laboratory

Dr. Kent Goering
Headquarters, Defense Nuclear Agency
U.S. Department of Defense

Dr. John Hall
Department of Civil Engineering
California Institute of Technology

Mr. Gary D. Johnson
Earthquake and Natural Hazards Division
Federal Emergency Management Agency

Dr. Steve Mahin
Department of Civil Engineering
University of California, Berkeley

Dr. Robert Oswald
Directorate of Research and Development
Headquarters, U.S. Army Corps of Engineers

Dr. Jerome Pearson
Structural Dynamics Branch
U.S. Air Force Wright Research and Development Center

Dr. Erdal Safak
U.S. Geological Survey

APPENDIX B: WORKSHOP AGENDA

AGENDA

Technical Review Panel Meeting
USACERL Biaxial Shock Test Machine
 US Army Construction Engineering Research Laboratory
 Champaign, IL
 26-27 July 1990

26 July 1990:

0815	Registration	BSTM Building:	Ms. Maurer
0830	Opening/Administrative Remarks	BSTM Building:	Mr. Hayes
0845	Welcome	BSTM Building:	Dr. Shaffer
0900	Introduction	BSTM Building:	Dr. Hall
0915	BSTM History & Overview	BSTM Building:	Mr. Gambill
1000	Break		
1015	Panel Discussion, "Use of Shaking Tables in Practice" Includes presentation by Mr. Conati USACERL Recorders: Mr. Gambill Mr. Wilcoski	TCl-3: Chairman:	Dr. Hall
1200	Lunch, catered at USACERL	TCl-3:	Mr. Hayes
1300	Simultaneous Panel Discussions "In-structure Shock Research and Shaking Tables" Panelists: Dr. Hall, Dr. Kiger, Mr. Woodson, Mr. Gaube, Mr. Jones, Dr. Baladi, Mr. Flathau, Dr. Higgins, Dr. Kana USACERL Recorders: Mr. Gambill, Mr. Wilcoski "Seismic Research and Shaking Tables" Panelists: Dr. Hall, Dr. Buckle, Mr. Lagario, Dr. Jirsa, Dr. Wight, Dr. Gould, Dr. Galambos, Mr. Tanouye USACERL Recorders: Ms. Brady, Mr. Al-Chaar Optional Added Panel Discussion, Topic TBD	TCl-3: Chairman:	Dr. Katona
1530	Break		
1545	Summary Session Includes summaries by Dr. Katona and Dr. Wright USACERL Recorders: Ms. Brady, Mr. Wilcoski	TCl-3:	Dr. Hall
1700	Adjourn		
1830	Social/Dinner		Chancellor Hotel

27 July 1990:

0830	Administrative	TCl-3:	Mr. Hayes
0845	Proposed BSTM Upgrade Includes presentation by Mr. Conati USACERL Recorders: Mr. Gambill, Mr. Wilcoski	TCl-3:	Mr. Hayes
0945	Break		
1000	Summary Session/Action Items USACERL Recorders: Ms. Brady, Mr. Gambill, Mr. Al-Chaar	TCl-3:	Dr. Hall
1200	Adjourn		

APPENDIX C: SUMMARY OF MAJOR U.S. BIAxIAL SHAKE TABLE CAPABILITIES

Figure C1 shows the basic horizontal motion capabilities of the USACERL BSTM (CERL), the SUNY Buffalo shake table (SUNY), and the UC Berkeley shake table (EERC). The graph provides a comparison of the basic capabilities of the three tables and a basic statement of current U.S. national capabilities.

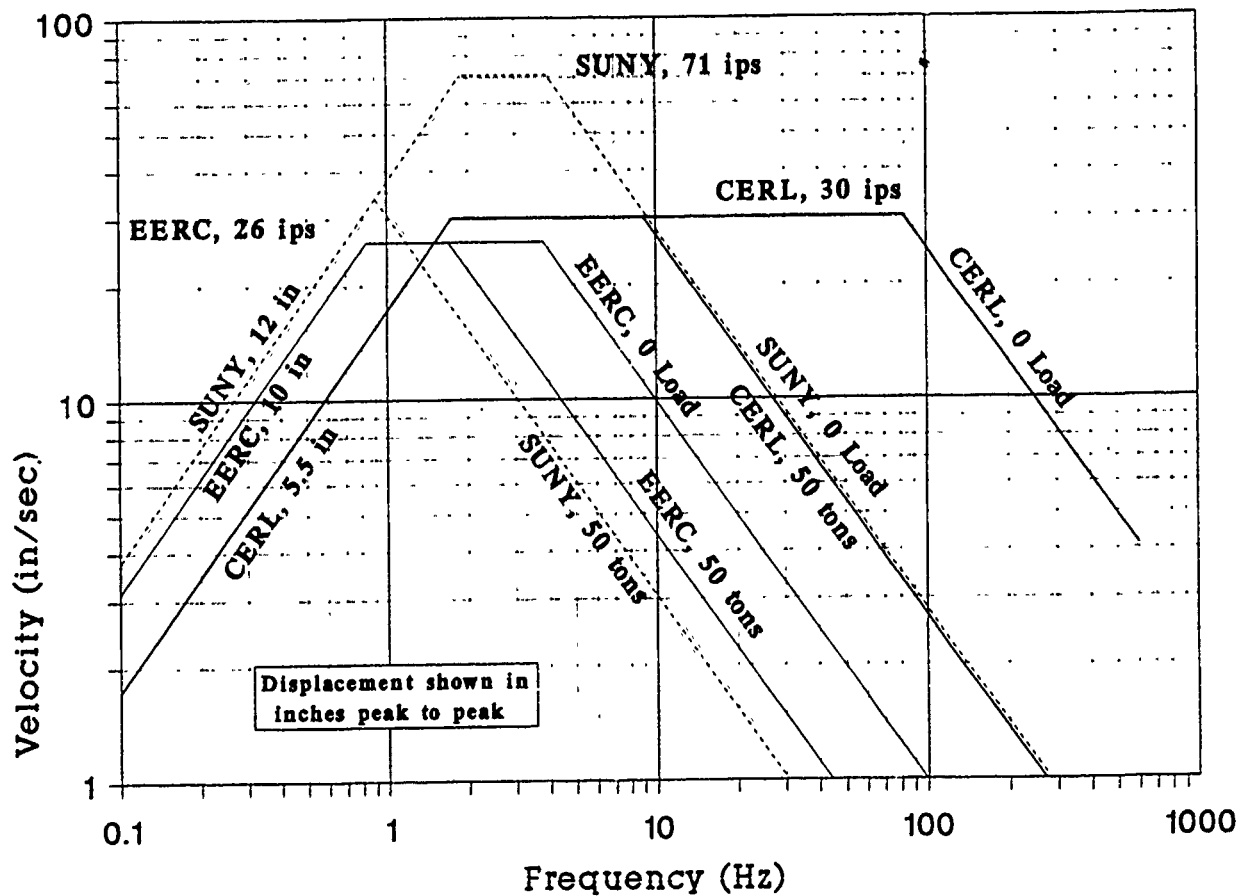

Figure C1. Basic horizontal motion capabilities.

APPENDIX D: SPECIFICATIONS FOR MAJOR SHAKE TABLE FACILITIES WORLDWIDE

Table D1

Specifications for Major Shake Table Systems;
Partial List by Date On Line, 1968-1989*

Institution	Date	Size (m)	Maximum Specimen Weight (t)	Vibration Direction	Max. Disp. (mm)	Performance		
						Max. Velocity (mm/sec)	Max. Accel. (g)	Frequency Range (Hz)
University of Illinois Urbana, Illinois, USA	1968	3.65 x 3.65	4.5	Uniaxial	H±51	381	5	0.1-50
University of California Berkeley, California, USA	1971	6.1 x 6.1	45	Biaxial	H±152 V±51	635	0.67	0.5-50
						254	0.22	
Construction Engineering Research Lab Champaign, Illinois, USA	1973	3.65 x 3.65	6**	Biaxial	H±73 V±35	813	15	0.1-200***
						686	30	
Kajima Institute of Construction Technology Chofu, Japan	1975	4.0 x 4.0	20	Biaxial	H±150 V±75	1140	2.0	0.1-50
						445	1.0	
University of Mexico Mexico City, Mexico	1975	4.5 x 4.5	20	Uniaxial	H±51	381	1.2	0.1-50
Ministry of Construction Tsukuba, Japan	1979	6.0 x 8.0	100	Uniaxial (Biaxial, 1983)	H±75	600	0.7	0.1-30
						635	0.67	
University of "Kiril and Metodij" Skopje, Yugoslavia	1980	5.0 x 5.0	40	Biaxial	H±125 V±50	380	0.40	0.1-30
						860	1.3	
Ansaldo Impianti (AMN) Genoa, Italy	1980	3.5 x 3.5	7	Biaxial	H±70 H±70	550	0.63	0.1-60

* The shake table facilities are listed in order of the date they were put into operation. The list, provided by MTS Corp., includes all major shake tables known to the authors, but is not necessarily comprehensive.

** Maximum weight listed is for high frequency, high acceleration testing. Seismic test capacity is at least 30 tons.

*** Table has been tested at 600Hz.

Table D1 (cont'd)

Institution	Date	Size (m)	Maximum Specimen Weight (t)	Vibration Direction	Performance			
					Max. Disp. (mm)	Max. Velocity (mm/sec)	Max. Accel. (g)	Frequency Range (Hz)
Toshiba Electric Co. Kawasaki, Japan	1980	5.0 x 5.0	20	Biaxial	H±75	400	1.0	0.1-30
					V±38	250	0.7	
Union Carbide Corp. Oak Ridge Tennessee, USA	1980	1.83 x 1.83	7	Biaxial	H±193	305	0.25	0.1-20
					V±193	305	0.25	
Ministry of Construction Tsukuba, Japan	1981	2.0 x 3.0 (4 tables)	25	Uniaxial	H±75	600	0.7	0.1-50
Sate University of New York Buffalo, New York, USA	1983	3.7 x 3.7	20	Biaxial	H±150	760	1.0	0.1-60
					V±75	500	1.0	
Tong Ji University Shanghai, Peoples Republic of China	1983	4.0 x 4.0	15	Biaxial	H±100	1000	1.2	0.1-50
					H±50	600	0.8	
Ishikawajima-Harima Heavy Industries Yokohama, Japan	1983	4.5 x 4.5	35	Triaxial	H±100	750	1.5	0.1-50
					H±100	750	1.5	
					V±67	500	1.0	
National Technical University Athens, Greece	1983	4.0 x 4.0	10	Triaxial	H±100	900	1.5	0.1-60
					H±100	600	1.1	
					V±100	800	1.8	
ISMES Bergamo, Italy	1984	4.0 x 4.0	20	Biaxial (Triaxial 1986)	H±90	900	1.0	0.1-60
					V±90	600	1.7	

Table D1 (cont'd)

Institution	Date	Size (m)	Maximum Specimen Weight (t)	Vibration Direction	Performance			
					Max. Disp. (mm)	Max. Velocity (mm/sec)	Max. Accel. (g)	
East China Technical University of Water Resources Nanjing, PRC	1984	2.0 x 2.8	6	Biaxial	H±50	500	1.2	0.1-80
					V±34	340	0.62	
Dalian Institute of Technology Dalian, PRC	1984	3.0 x 3.0	10	Uniaxial	H±75	500	1.0	0.1-50
Yunnan Institute of Tech. Kunming, PRC	1984	1.5 x 2.0	2.5	Biaxial	H±75	800	2.4	0.1-80
					V±50	800	1.7	
National Committee for R&D of Nuclear and Alternative Energies (ENEA) Rome, Italy	1985	4.0 x 4.0	10	Triaxial	H±125	500	3.0	0.5-50
					H±125	500	3.0	
					V±125	500	3.0	
Nippon Telephone and Telegraph (NTT) Tokyo, Japan	1985	3.0 x 3.0	10	Triaxial	H±150	1000	5.0	1-100
					H±150	1000	5.0	
					V±150	1000	5.0	

Table D1 (cont'd)

Institution	Date	Size (m)	Maximum Specimen Weight (t)	Vibration Direction	Max. Disp. (mm)	Performance		
						Max. Velocity (mm/sec)	Max. Accel. (g)	Frequency Range (Hz)
Research Institute for the Electrotechnical Industry Bucharest, Romania	1986	2.0 x 2.0	0.50	Triaxial	H±265	2140	5.0	0.5-33
					H±265	2140	5.0	
					V±177	1430	3.33	
German Army Testing Institute Meppen Germany Army Meppen, West Germany	1986	0.75 x 0.75	0.06	Triaxial	H±324	4700	7.7	0.5-33
					H±324	4700	7.7	
					V±217	3150	5.0	
Kumagai-Gumi Corp. Tokyo, Japan	1987	5.0 x 5.0	70	Triaxial	H±50	2000	5.0	1-100
					V±50	2000	5.0	
Power Reactor and Nuclear Fuel Development Corp. Oarai, Japan	1988	2.5 x 3.0	6	Biaxial	H±80	600	3.0	0.1-70
					H±260	1500	1.0	
					V±50	500	1.0	
Kajima Corp. Tokyo, Japan	1989	5.0 x 5.0	50	Triaxial	H±100	1000	3.0	0.1-100
					V±75	1000	3.0	
					H±200	1000	2.0	
Korea Institute of Machinery and Metals Chung-Nam, Korea	1989	4.0 x 4.0	30	Triaxial	H±200	1000	2.0	0.1-60
					V±100	500	2.0	
					H±200	750	1.5	
Korea Institute of Machinery and Metals Chung-Nam, Korea	1989	4.0 x 4.0	30	Triaxial	H±200	750	1.5	0.1-50
					V±134	500	1.0	
					H±200	750	1.5	

The UB Seismic Simulator

Since the late 1960's, the State University of New York at Buffalo has been engaged in the construction of a new campus in the suburban town of Amherst. When completed in the late 1980's, the new campus will have cost more than one-half billion dollars, and will house the entire UB Faculty of Engineering and Applied Sciences.

The Department of Civil Engineering, in planning for its new facilities, decided to build its strength in structural and geotechnical engineering by developing dynamic experimental capabilities. After a long period of careful consideration of advice provided by various distinguished structural and geotechnical engineers, educators and researchers, the faculty and administration decided to develop an earthquake simulation facility as a major experimental adjunct to its structural and geotechnical engineering laboratories.

A more intensive study of the design of the new laboratory was made in 1977 just prior to the beginning of building construction. Faculty members visited most major earthquake simulators in the U.S. to seek advice from key people in charge of those facilities. These efforts reinforced the earlier conclusion that it would be desirable to construct a shaking table in order to provide additional experimental research capabilities and manpower training in Earthquake Engineering in the northeastern part of the country.

Much consideration was given to the size, type and dynamic characteristics of the shaking table. The final decision on the design was made in 1979, based on budget tradeoffs and on special characteristics and capabilities of other

available facilities in the U.S. The total cost of the entire system, including the foundation, plumbing, construction of the "table," an automated control/analysis digital computer package, and an interface with the analog system was in excess of \$1.5 million. The State University of New York provided most of the monies. The National Science Foundation provided a major grant toward the purchase of the automated control and data acquisition system. Significant local funds were received from the Baird Foundation, the Seymour Knox Foundation, Delaware North Companies, Dr. Robert L. Ketter and the University at Buffalo Foundation, Inc.

Description

The MTS Systems Corporation's biaxial test system at UB represents the most versatile seismic simulator in North America. It will be comparable to the system at the Kajima Institute of Construction Technology in Japan, which is the most advanced system in the world today.

One of the unique features of the UB system is the shaking table, which is constructed of ferrocement with reinforcing rods located biaxially in the table. The rods are capable of tension adjustment to "tune" the table structure with the test loads mounted on it. The shaking table has five controlled degrees of freedom (See Figure 1).

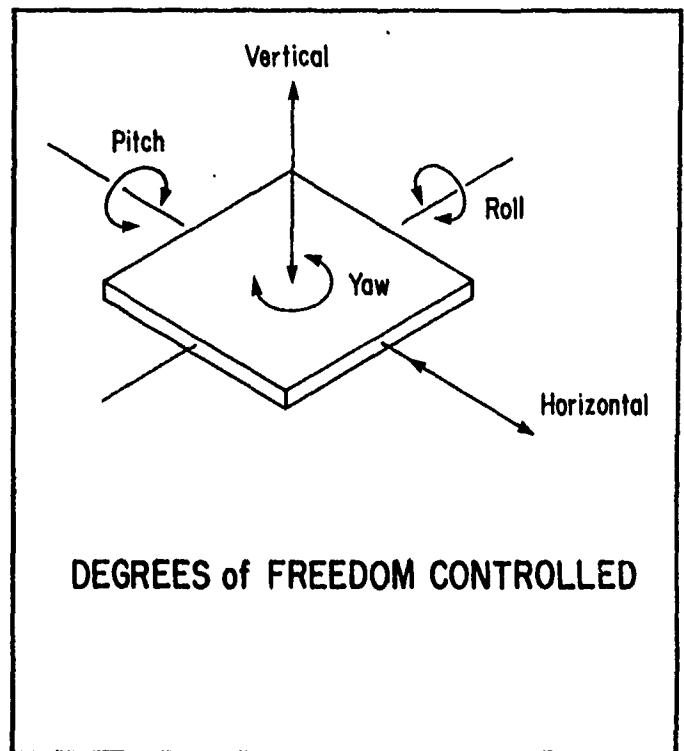

Figure E1. Degrees of freedom controlled.

* The material in Appendix E was provided by Dr. Ian Buckle, Deputy Director, National Center for Earthquake Engineering Research, State University of New York at Buffalo.

Three of these — horizontal, vertical and roll — are programmable. The system is expandable for future third axis actuation.

Restraint against lateral movement of the table is provided by hydrostatic bearings mounted on the table and applying force against a bearing surface on each side of the pit. The bearings are self-compensating for alignment and are omnidirectional in a plane normal to the table motion.

Motion is produced in both the vertical and horizontal directions by servo-controlled, electrohydraulic actuators arranged as shown in Figures (2) and (3). Single and biaxial tests may be performed depending upon the test objectives. All adjustments to the controls are made from the control room, either through manual controls or digital programming. These motions can simulate earthquake conditions or reproduce actual earth motions that have been recorded for laboratory studies and analysis.

Hydraulic power is delivered to the actuators from motor-driven hydraulic power supplies through hardline plumbing in the building. Service manifolds and flexible hoses are supplied as part of the system to connect to the moving actuators. These provide filtration and flow control of the hydraulic fluid in the system.

The drive waveforms available are Sine, Square, Triangle, Random and Earthquake. Using these basic forms, the wave shapes that could be generated by the shaking table systems are:

- Single Frequency Test
- Continuous Sine Test
- Sine Beat Test
- Decayed Sine Test

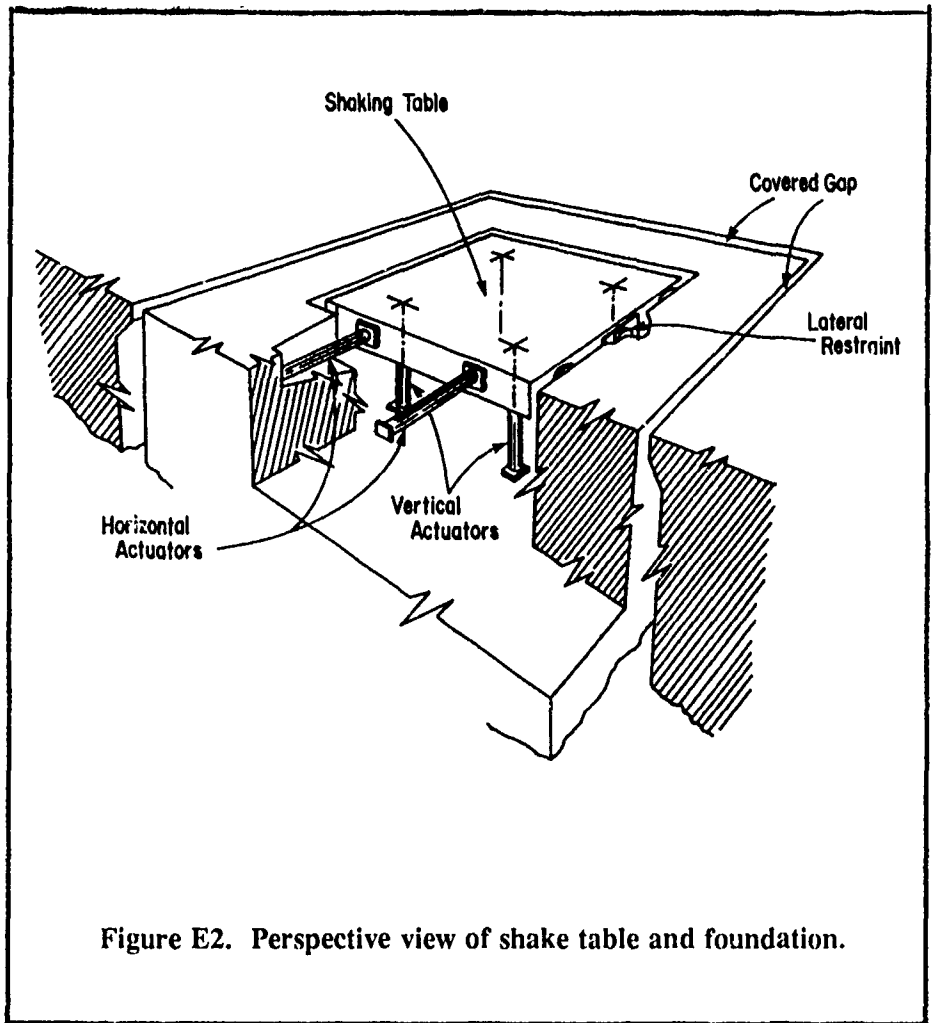

Figure E2. Perspective view of shake table and foundation.

- Variable Frequency Sine Sweep Test
- Multiple Frequency Test
- Time History Test
- Real and Simulated Earthquake Record Test
- Random Motion Test
- Complex Wave Test
- Initial Velocity Test
- A combination of any of the above

While the Seismic Simulator at UB is smaller in size than some other installations in the U.S., it exceeds every other domestic simulator and most of the foreign simulators in its ability to produce greater forces in the horizon-

tal and vertical directions, as well as at higher frequencies. The special characteristics of the facility are summarized in the following sections:

Characteristics of the foundation
(See Figures 2 and 3)

Dimensions: 7.9 m x 6.1 m x 7.6 m deep
(26 ft. x 20 ft. x 25 ft. deep)

Isolation: Resting on bedrock (limestone), surrounded by a 1 ft. gap between the foundation and the building

Weight of Foundation: 700 metric tons
(1,550,000 lbs.)

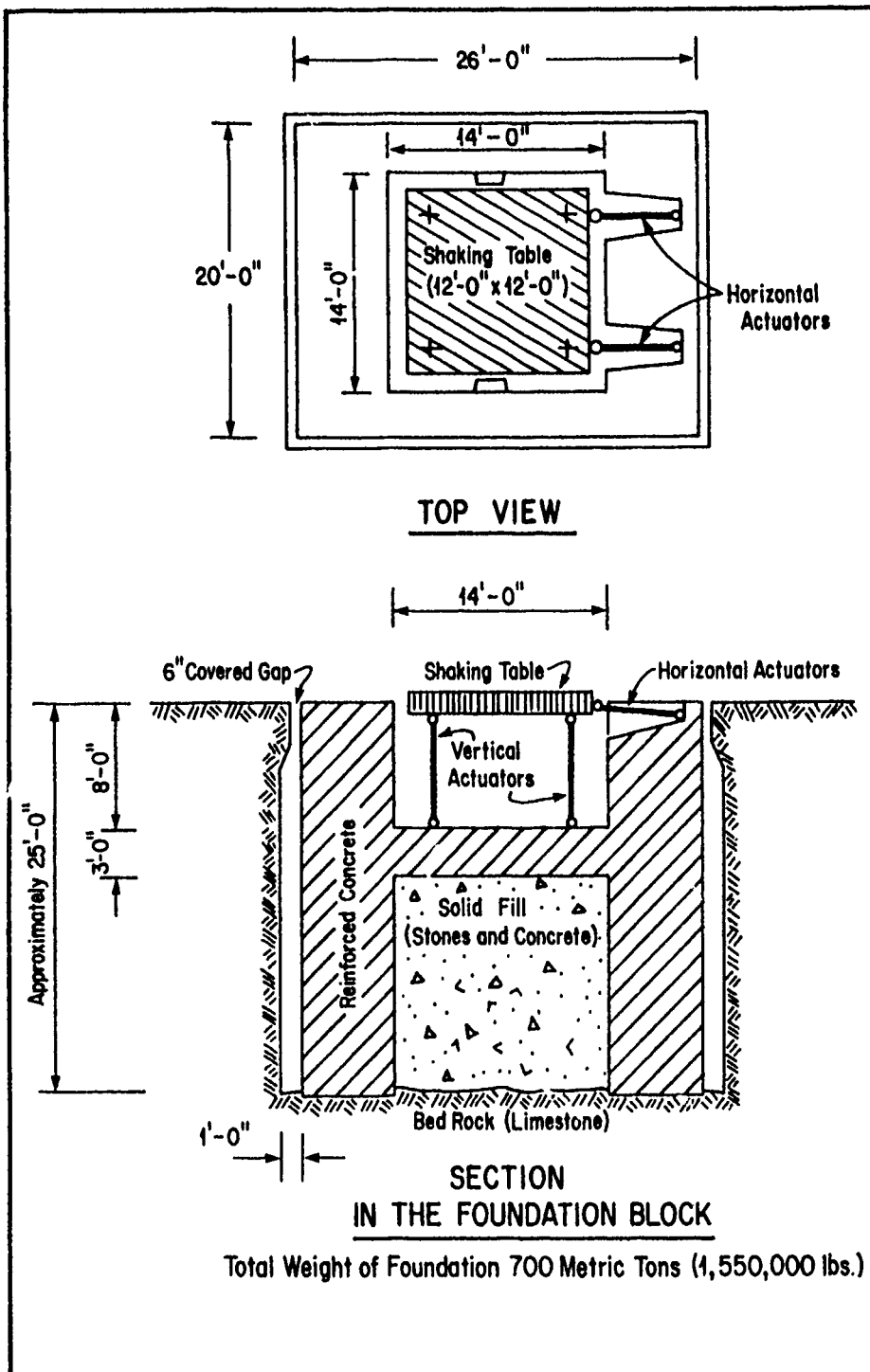

Pit: 4.3 m x 4.3 m x 2.4 m deep (14 ft. x 14 ft. x 8 ft. deep)

Dominant Frequencies:

- Horizontally — 83 Hertz
- Vertically — 95 Hertz
- Rocking — 58 Hertz

Characteristics of the table
(See Figure 4)

Size: 3.6 m x 3.6 m x 0.38 m (12 ft. x 12 ft. x 15 in.)

Weight of Table: 7.5 metric tons (16,500 lbs.)

Average Density of Table: 1.5 metric tons/cubic meter (91 lbs./cubic ft.)

Maximum Model Size: 3.6 m x 3.6 m x 7.0 m (12 ft. x 12 ft. x 23 ft.)

Maximum Model Weight: 50 metric tons (10,000 lbs.)

Maximum Overturning Moment: 46 meter-metric tons (330,000 ft. lbs.)

The overall performance characteristic of the table (and system) are shown in Figures 5 (for horizontal motion) and 6 (for vertical motion).

Figure E3. Section in the foundation block.

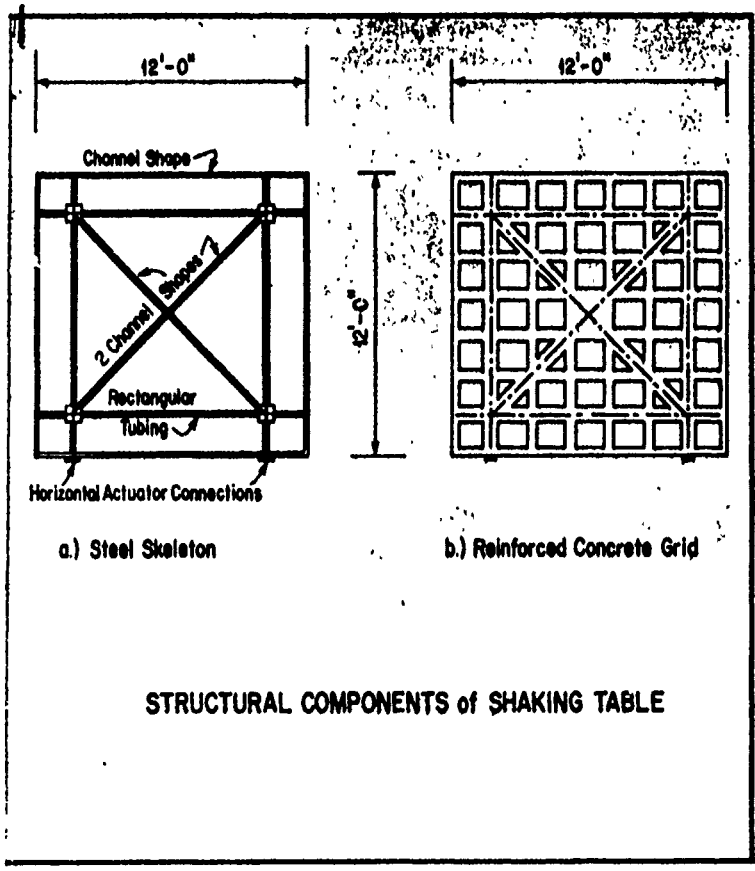
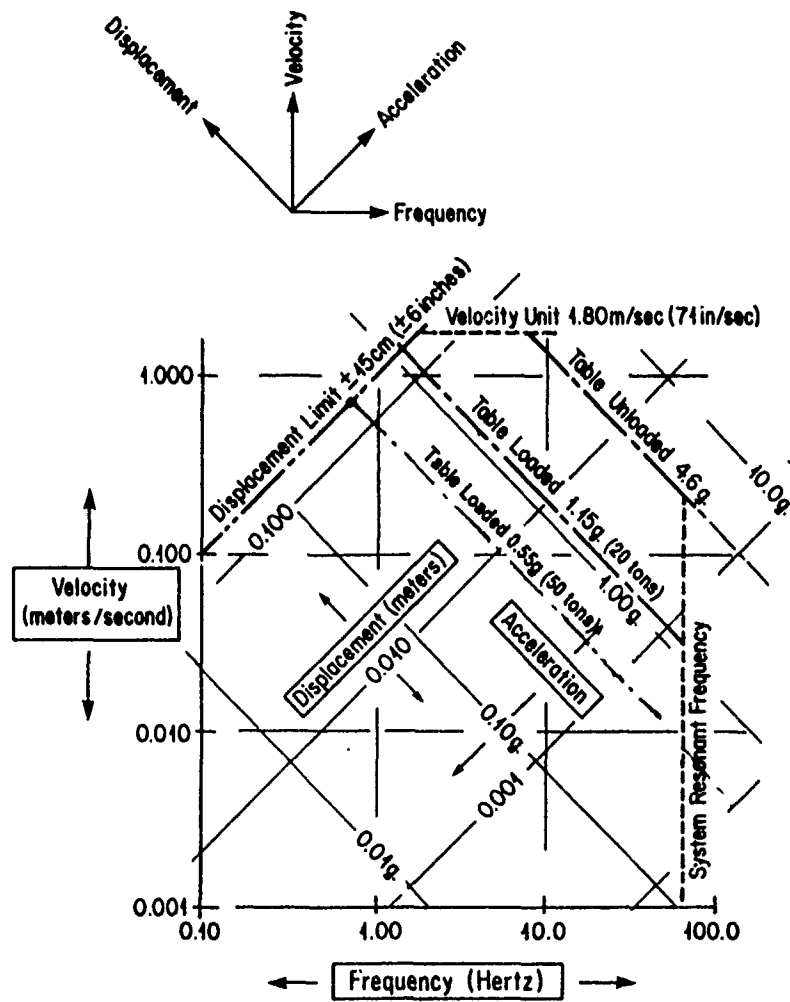

Figure E4. Structural components of shake table.



LIMITS of HARMONIC HORIZONTAL MOTION

Figure E5. Limits of harmonic horizontal motion.

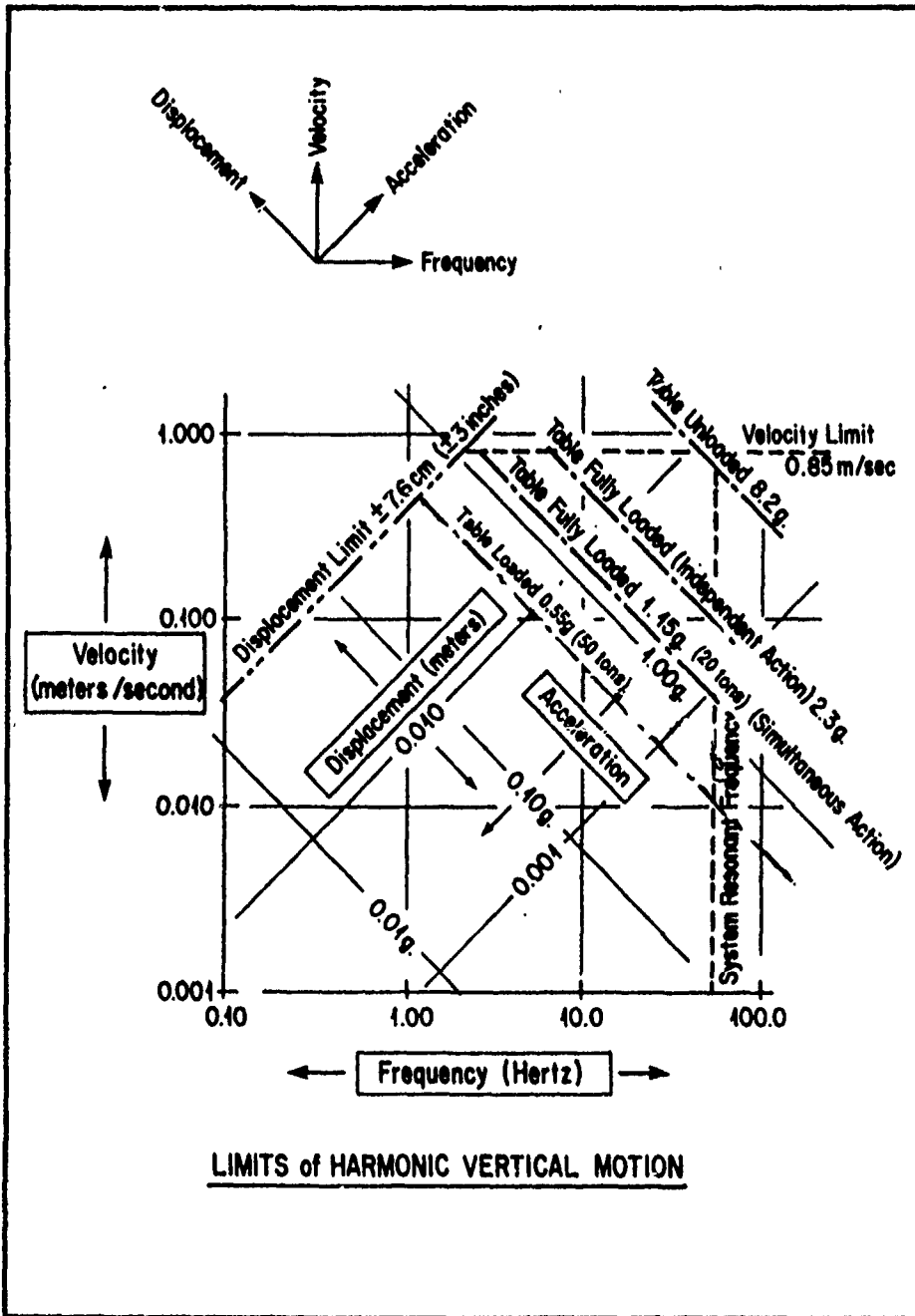

Figure E6. Limits of harmonic vertical motion.

System operation

Nature of System: Closed-Loop, Servo-Controlled, Electro-Hydraulic (See Figure 7)

Number, Type and Size of Actuators:
 Horizontal - 2 Hydraulic Actuators ($\pm 35^k$ /Actuator)
 Vertical - 4 Hydraulic Actuators ($\pm 50^k$ /Actuator)

Hydraulic Power Supply: Two - 140 gpm @ 3000 psi

Table control

Equipment Used to Command Shaking Table: PDP 11/34A Minicomputer (with 256^k Memory)

Device for Analog Input to Command Shaking Table: Computer, Function Generator

Device to Monitor Performance: Oscilloscope, Oscillograph, Frequency Analyzer, Graphic Displays

Data acquisition system

Number of channels: 64w/A-D (128 FUTURE), PLUS 30wo/A-D

- 400 channels of acquisition

Analog Recording Capability: Multi-Channel Strip Chart Recorder
 x-y-z Plotters
 Tape Recorder
 Video Recording

Digital Recording Capability: 9 Track Tape Drive, Graphic Display and Copy Unit

Analog to Digital Conversion Capability: 64 channels (Expandable to 128)

Devices to Record Analog Output:
 Tape Recorder
 Oscillograph
 Chart Recorders
 Computer

Instrumentation

A variety of instrumentation for direct measurement of dynamic response quantities are available. These include:

- Force Transducers
- Velocity Transducers
- Linear and Rotational Accelerometers
- Potentiometers
- Extensometers
- LVDT's
- RVDT's
- Strain Gauges

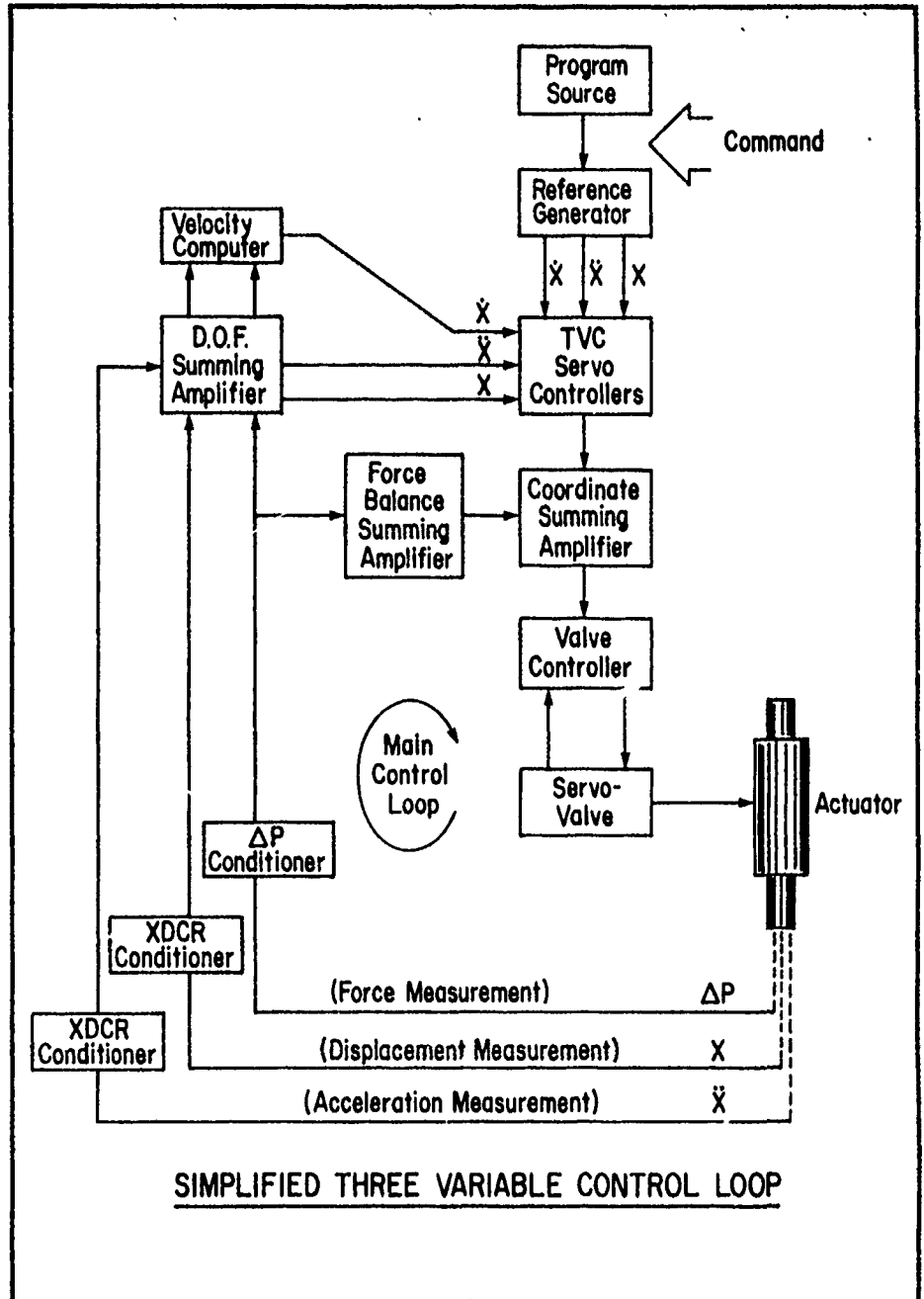

Figure E7. Simplified three-variable control loop.

APPENDIX F: UNIVERSITY OF CALIFORNIA AT BERKELEY EARTHQUAKE ENGINEERING RESEARCH CENTER*

The Earthquake Engineering Research Center (EERC) was established as an organized research unit of the College of Engineering in 1968. The Center's primary function has been to facilitate and coordinate earthquake engineering research at the Berkeley Campus of the University of California.

Experimental activities comprise an important element of the overall research program. To support these activities, EERC maintains an earthquake simulator and other experimental equipment for conducting dynamic as well as pseudo dynamic research. The laboratories for these facilities are located at the University's Richmond Field Station (RFS), 1301 S. 46th St., Richmond, CA.

The Earthquake Simulator or "shake table" was the first of its kind ever built in the world and is still the largest one in the United States. The earthquake simulator is located in Building 420, a separate, specially designed structure 40 ft high, 60 ft wide and 120 ft long. It is serviced by a 10-ton bridge crane and houses the earthquake simulator with its control and data acquisition facilities, an enclosed yard for fabrication and erection of test structures, and electronic maintenance room, as well as offices.

The central feature of the laboratory is the 20 by 20 ft shake table. Table F1 lists its basic specifications. The table is currently configured to produce two translational components of motion: vertical and horizontal. These two degrees of freedom can be programmed to reproduce any wave forms within the capacities of force, velocity, displacement, and frequency of the system. It may be used to subject structures weighing up to 100,000 lb to horizontal motions of about twice the intensity of the N-S (north-south) component of the El Centro (1940) earthquake, and simultaneously, to vertical motions about twice the intensity of the vertical component of the same earthquake.

The concrete shake table is heavily reinforced both with ordinary reinforcement and with post-tensioning tendons. Structurally, the table may be considered a 1 ft thick slab stiffened by heavy central transverse ribs that extend below its bottom surface. The hydraulic actuators that drive the table horizontally are attached to the table by means of one of the transverse ribs. The vertical actuators, as well as the structures to be tested are attached to the table by prestressing rods located in 2-in.-diameter openings piercing the table vertically on a 3-ft-square grid. The table itself weighs 100,000 lb. It was designed to be stiff enough to have a natural frequency greater than 20 Hz and thus behaves essentially as a rigid body in the operating range of 0-10 Hz.

The shake table is currently driven horizontally by three 70,000 lb hydraulic actuators, and vertically by four 25,000 lb actuators, located in the pit below it. The actuators have swivel joints at both ends so they can rotate to accommodate components of motion perpendicular to their direction of extension. The total length of each horizontal actuator, including swivel joints, is 10 ft, 6 in., and the total length of each vertical actuator is 8 ft, 8 in. The length of the actuators helps to decouple the horizontal and vertical components of motion; further decoupling is accomplished in the control system.

In operation, the air in the pit beneath the shake table is pressurized so the total weight of the table and the structure being tested is balanced by the difference in air pressure in the pit and ambient air

* The material in Appendix F was provided by Dr. Steve Mahin, University of California at Berkeley.

Table F1

EERC Shake Table Specifications

Plan dimensions	20 ft x 20 ft
Model tie-down locations	2-in.-diameter holes @ 36 in. on center
Model weight capacity	130 kips (578 kiloNewtons [kN])
Overhead clearance	40 ft to ceiling 32 ft to 10-ton crane
Overturning resistance	3,343 kip-ft (4,532 kN-m)
Displacement	Horizontal \pm 5 in. Vertical \pm 2 in.
Velocity	Horizontal \pm 25 in./sec (ips) Vertical \pm 15 ips
Acceleration	Horizontal \pm 1.5 gal (cm/sec ²) Vertical \pm 1.0 gal
Bandwidth	0-20 Hz

pressure. The pit entrance is sealed by two airtight doors that provide a lock chamber and thus permit access to the pit while the air in the pit is pressurized. The 1 ft horizontal gap between the edge of the table and the interior foundation walls is sealed by a 24-in.-wide strip of vinyl covered nylon fabric. A differential air pressure of 1.55 pounds per square inch (psi) is required to balance the weight of the shake table alone.

At frequencies lower than 1 Hz, the intensity of motion that the table can develop is limited by the maximum and minimum displacements of the actuators. At intermediate frequencies from 1 to 4 Hz, the intensity of motion is limited the actuator velocities. And at frequencies greater than 4 Hz the intensity of motion is limited first by the actuator force capacities and later by the frequency response characteristics of the system comprised by the table, structure and actuators.

The actuator forces react against a massive foundation, which is a reinforced concrete structure in the form of an open box with 5-ft-thick sides. The outside dimensions of the box are 32' x 32 by 15 ft, and the inside dimensions are 22 x 22 x 10 ft. The foundation weighs 1,580,000 lb.

Hydraulic power for the entire facility supplied at 3000 psi by four 80 gallons per minute (gpm) pressure-regulated pumps, each of which is driven by a 120 hp electric motor. Accumulators that can double the peak instantaneous flow rates are installed in the main oil line, but the oil supply is not currently sufficient to produce maximum horizontal and vertical velocities simultaneously. However, it

is considered unlikely that the maximum horizontal and vertical components of an earthquake would occur simultaneously.

Plans are now in progress to significantly increase the shake table capacities by providing another horizontal component of motion, by increasing the force capacities of the vertical and horizontal servo systems, and by increasing the hydraulic power.

APPENDIX G: SOUTHWEST RESEARCH INSTITUTE SHAKE TABLE DESCRIPTION*

SPECIFICATIONS FOR SwRI SEISMIC TEST FACILITY

System Description

This facility has the capability of realistic simulation of earthquake motions as well as many other low frequency dynamic environments. It is a true biaxial vibration table having the capability of delivering simultaneous independent excitation along both horizontal and vertical axes. Drive mechanisms are servocontrolled, with independent control for each axis. It is capable of producing all current types of nuclear plant seismic qualification tests prescribed under USNRC Reg. Guide 1.100 and IEEE 344 (1975), and many other types of tests as well. Detailed capabilities include:

Max. Payload Weight: 6000 lb

Payload Mounting Area: 6 ft x 6 ft

Payload Max. Envelope: 10 ft wide x 10 ft deep x 14 ft high

Max. Payload CG: Height 2 ft for 5000 lb; Above Table Top 4 ft for 3000 lb; 6 ft for 1000 lb

Table Limits	Horizontal	Vertical
Frequency Range	0 - 100 Hz	0-100 Hz
Force Capacity	10,000 lb	20,000 lb
Max. Stroke	8 in.	7 in.
Max. Velocity	90 in./sec.	22 in./sec
Max. Acceleration	10 g	10 g

Associated Instrumentation

Excitation signals are provided typically by random or deterministic function generators, or actual field-measured signals recorded on analog tape. Table displacement is accurately controlled at low-to-medium frequencies by automatic feedback. Table motions are monitored by accelerometers whose outputs can be analyzed according to several standard parameters. Acceleration or velocity response spectrum can be computed and plotted within seconds. Power spectral density, probability density, and other associated statistical parameters can be computed with Real Time Analyzers. All time histories can be recorded on analog or digital tape, on oscillographs, or monitored on oscilloscopes.

For Further Information, Please Contact:

R. L. Bessey, Manager
Structural Dynamics and Environmental Testing
Department of Mechanical Sciences
Southwest Research Institute
6220 Culebra Road
San Antonio, TX 78284
Phone (512) 684-5111

* The material in Appendix G was provided by Dr. Daniel D. Kana, Southwest Research Institute, San Antonio, TX.

APPENDIX H: USACERL BIAXIAL SHOCK TEST MACHINE

The BSTM can evaluate the performance of structures, models, and equipment in resisting biaxial motions applied in individually controlled horizontal and vertical directions over a broad frequency range (0-600 Hz). The motions are generated by nine vertical and six horizontal hydraulic actuators that can produce motions within the ranges shown in Figures H1 and H2.

The BSTM is made up of four major subsystems: the hydraulic-powered test platform, analog control, test instrumentation, and digital control.

The test platform is a 12-ft-square aluminum weldment based on cellular web construction. Aluminum reduces the overall weight, while the cellular design provides required stiffness. The platform weighs about 12,000 lb and has a first modal resonance near 200 Hz.

Nine vertical electrohydraulic actuators drive the test platform with a total force of 810,000 lb over a stroke range of 2.75 in. The six horizontal actuators drive the test platform with a total force of 450,000 lb over a stroke range of 5.5 in. Maximum actuator velocity is 30 in./sec. The hydraulic power for this system is provided by a 280 gpm hydraulic power supply operating at 3000 psi. An additional 1800 gal accumulator is provided to give short-term bursts (10 to 12 seconds) of maximum energy to simulate maximum shock and seismic disturbances. A unique foundation minimizes undesirable cross-coupling between vertical and horizontal forces. No feasible means were found to have a single foundation react satisfactorily in both directions, so separate foundations were designed for vertical and horizontal reactions. Their combined volume is 1000 cu yd, with a weight of about 4,000,000 lb.

Analog Control System

The analog control system controls each actuator individually with a separate closed-loop control circuit consisting of three closely integrated feedback loops. By interconnecting the control loops of the individual actuators (nine vertical and six horizontal), control of five degrees of table motion is possible: vertical, horizontal, pitch, roll, and yaw. The sixth degree of motion—lateral displacement—is restrained by a combination of spherical hydraulic bearings. Appropriate pitch, roll, and yaw compensation is algebraically added to the average vertical and horizontal commands to ensure biaxial performance.

In addition to the control of the five primary degrees of freedom, several secondary parameters are also controlled through the use of five compensation functions, which are incorporated into the analog control system:

1. Force balancing. This function ensures that all actuators in a given direction work together instead of against one another. This is accomplished by monitoring the pressure difference across each actuator and comparing it with the appropriate vertical or horizontal average pressure.
2. Overshoot and ringing. Two forms of rate stabilization are used to control overshoot and ringing. Overshoot compensation is accomplished by differentiating the average displacement signals and subtractively combining this with the normal error signal to the actuator. Ringing compensation is accomplished by combining the average force (i.e., the average pressure difference feedback signal) with the normal error signal.

3. Stabilization. The oil spring-mass characteristic of each actuator changes as the piston moves from the mid-stroke position to either end position. Stabilization compensation is accomplished by using diode-function generator circuits to simulate the oil column-displacement curve and modify the amount of overshoot and ringing compensation applied to each actuator.

4. Center of gravity. When payloads are mounted on the platform, the combined platform-payload center of gravity is located above the horizontal actuators' lines of force. In plan view, the specimen's center of gravity may not exactly coincide with that of the platform. Compensation for the resulting pitch, roll, and/or yaw forces is accomplished by sensing the average vertical and horizontal forces in the pitch, roll, and yaw axes and applying an error correction signal to the appropriate actuators.

5. Cross-coupling. If the vertical actuators are at a fixed length during horizontal motion, the test platform pivots around the vertical actuators. Cross-coupling compensation is accomplished by sensing the vertical and horizontal displacements and applying an error signal of appropriate polarity to the vertical actuators, which extends or retracts them to maintain the platform in a level horizontal position.

Digital Control System

The digital control system consists of two GenRad 2514 minicomputers with mass storage and display peripherals. These units are used in the generation of test control waveforms, control of the shock and vibration tests, and the data acquisition and analysis of the test platform and test item response waveforms.

Test control is achieved by the digital generation of time history waveforms that control the movement of the BSTM platform to meet the requirements of each vibration test. The system has the capability to replicate field-recorded shock, seismic, or random vibration environments. It can synthesize time history waveforms to meet the requirements of predetermined shock response spectra or power spectra. It can also perform sine sweep vibration tests and experimental modal analyses.

The digital system is also used to acquire test response data in real time during a BSTM test and after a test by replaying data from a multichannel instrumentation tape recorder. A variety of microcomputer- and minicomputer-based software is used to perform time domain and frequency domain analyses.

The BSTM test instrumentation system consists of a 60-channel modular signal conditioning system that easily adapts to a wide variety of measurement transducers; e.g., accelerometers, load cells, extensometers, strain gages, pressure gages, and general functional parameter measurements that can be used to determine the performance of an operating piece of equipment while it is being tested.

Test response data are normally recorded on a 70-channel magnetic tape recorder as a permanent data archive. The recorded data are replayed and acquired by the digital computer system for post-test analysis and display.

Related Testing Capabilities

The BSTM is supplemented by other structural materials testing hardware available for integrated testing at USACERL. This hardware includes:

1. Structural load floor for experimental testing: open area 40 by 120 ft, reinforced concrete floor slab 2 ft thick with 6 in.-diameter floor mounting holes on 3-ft centers. A structural steel "erector set" of various-sized (list available) members is available for fabrication of test article supports and loading fixtures.

2. Manually operated hydraulic jacks: 16- and 30-ton capacities.

3. Hydraulic actuators: controlled electronically via closed loop/stroke and load controllers. Two 50,000 lb actuators and three 25,000 lb actuators available. Frequency range is 0-50 Hz.

4. Load floor instrumentation: 100-channel data acquisition with a variety of transducers. Microcomputer- and minicomputer-based data acquisition systems for static and dynamic tests.

5. MTS load frames: 1,000,000 lb and 50,000 lb frames.

6. MTS 50,000 lb load actuator mounted on steel columns.

7. Unholtz-Dickie electrodynamic shaker: 1400 lb peak force, 1.25 in. stroke, 70 g free table peak acceleration, 3350 Hz free table axial resonant frequency.

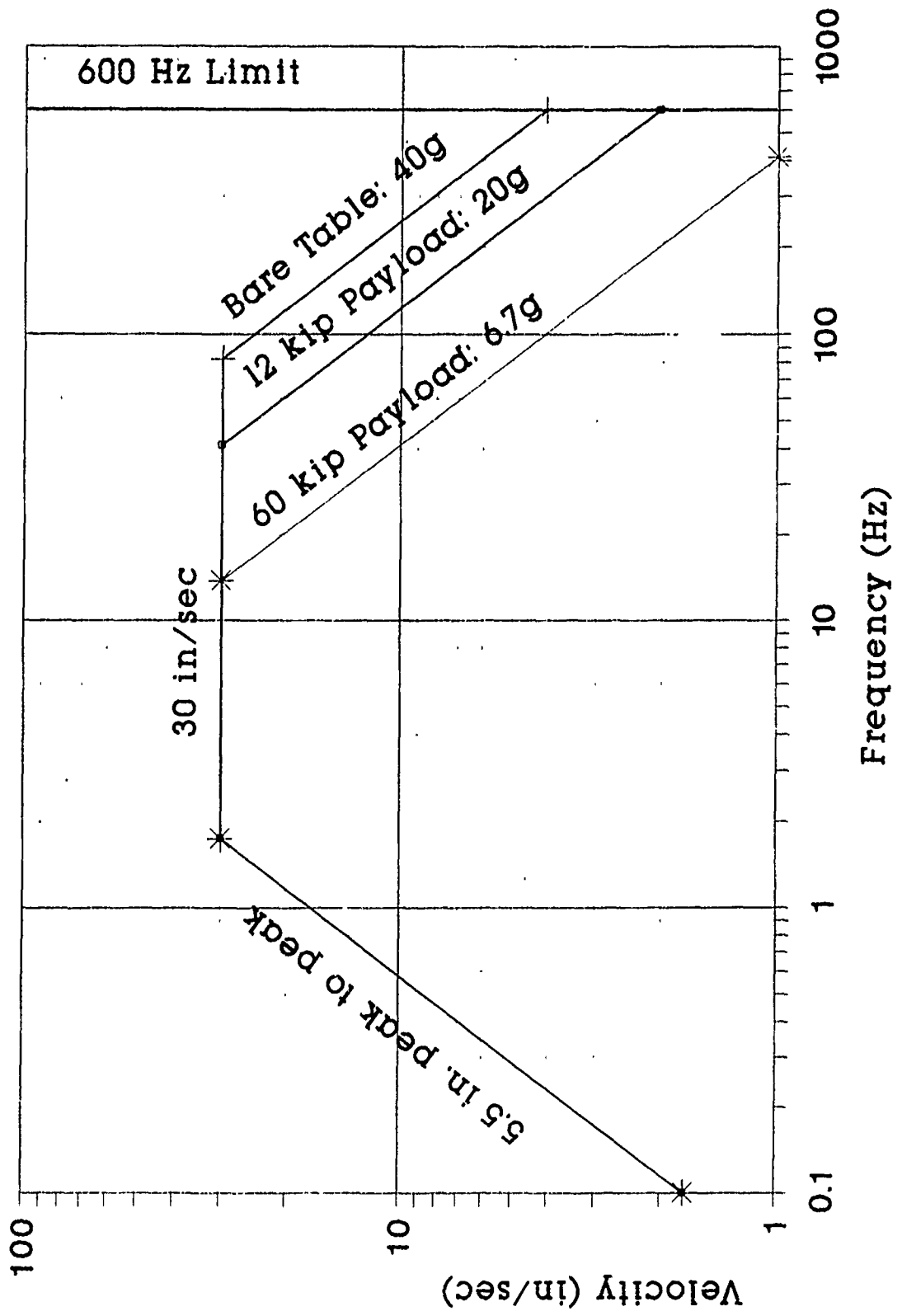

Figure H1. USACERL BSTM horizontal performance.

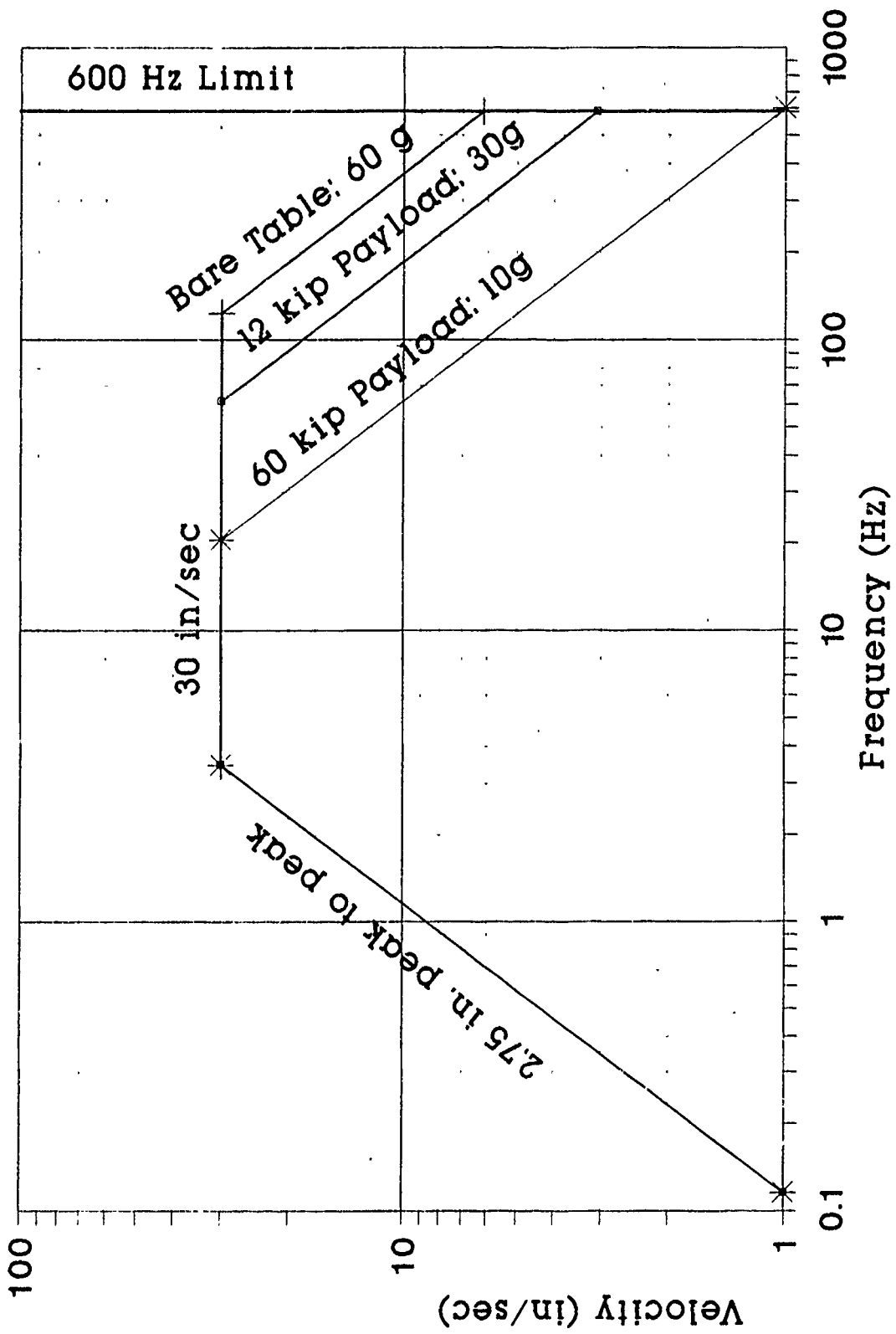

Figure H2. USACERL BSTM vertical performance.

APPENDIX I: IN-STRUCTURE SHOCK FIELD-TEST DATA

As background information for the in-structure shock panel discussions, several panelists provided plots of structural motion data, some measured in tests and some calculated using existing predictive techniques. These plots can serve as measures of the BSTM's capability to perform equipment fragility and vulnerability testing. This appendix contains excerpts of that information. The excerpts show areas where the BSTM performance envelope fails to equal peak motion parameters that can be anticipated when weapons detonate near protective structures.

The first series of graphs (Figures I1 through I5) presents tripartite plots of data derived from acceleration-time histories in a series of explosives field tests conducted by USAWES for Headquarters, Air Force Engineering Services Center (HQ AFESC). Basic capabilities of the BSTM have been superimposed on these plots. Figure I1 shows a plot of field-test data compared to the performance envelope of the BSTM with no payload. Figures I2 through I5 show plots of similar data compared to the performance envelope of the BSTM with a payload of 12,000 lb.

The second series of graphs (Figures I6 through I14) presents information derived analytically by JAYCOR, Inc., in conjunction with research it has recently performed.

The final series of graphs (Figures I15 through I17) presents a compilation by the U.S. Air Force Weapons Laboratory (AFWL) of the primary characteristics of different structural shock environments, and it shows some fragility data for general equipment types.

The panelists discussed the significance of the BSTM's motion capabilities as compared to these anticipated motion characteristics.

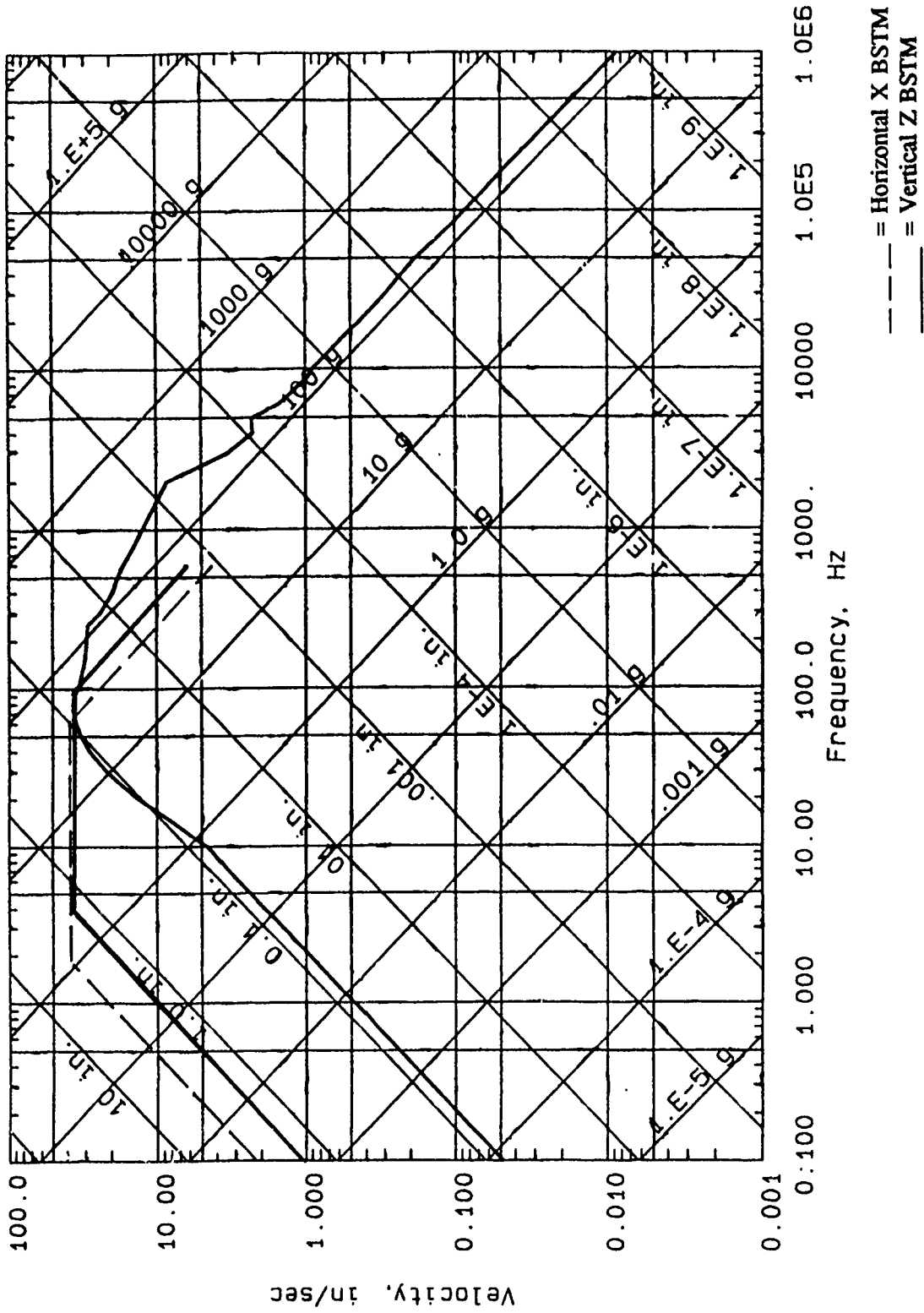

Figure 11. Shock spectra—subsurface detonation, Gage AFX-04, Event 13 (no payload).

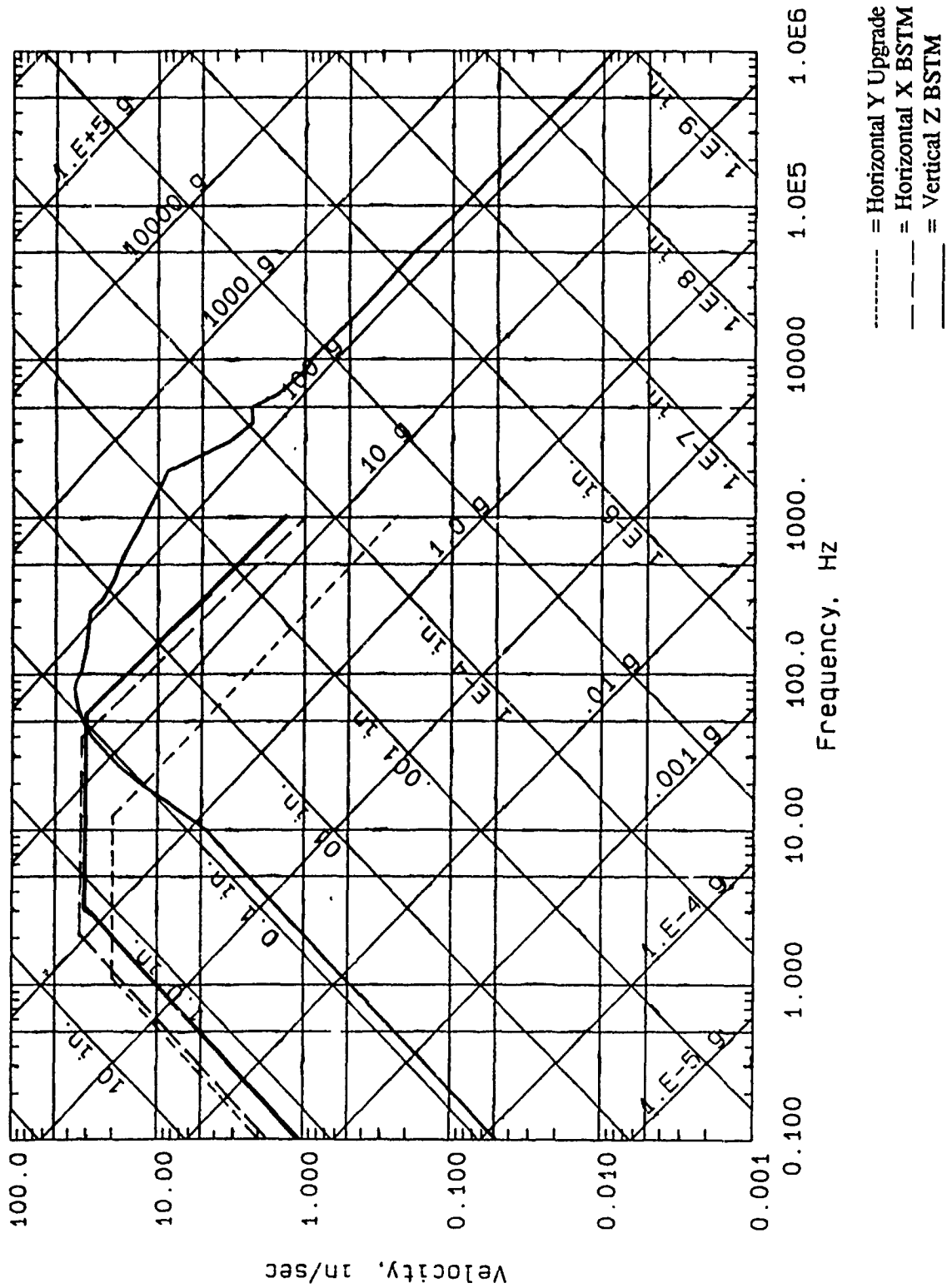

Figure 12. Shock spectra—subsurface detonation, Gage AFX-04, Event 13 (12,000 lb. payload).

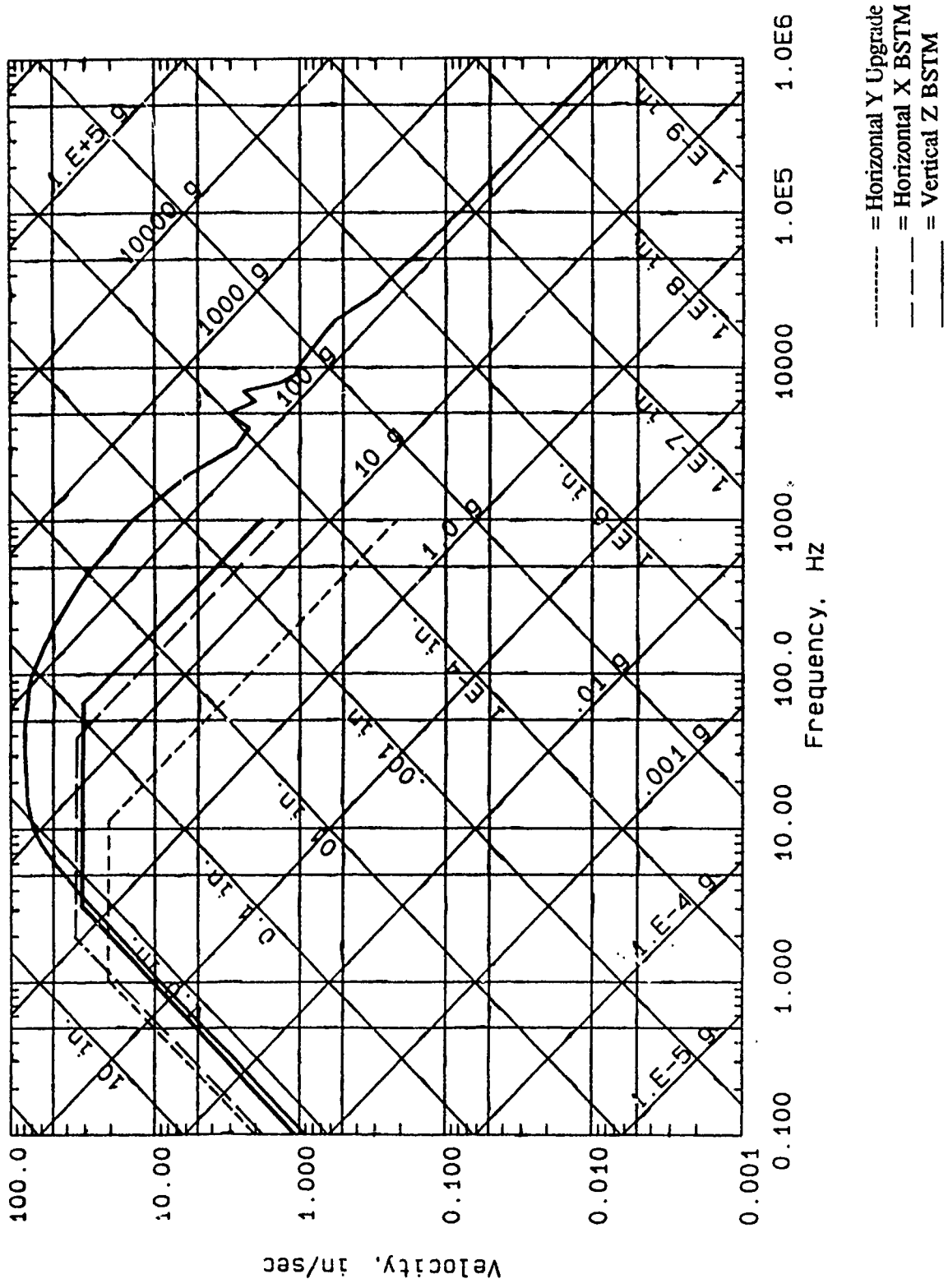

Figure 13. Shock spectra—subsurface detonation, Gage AFY-04, Event 13.

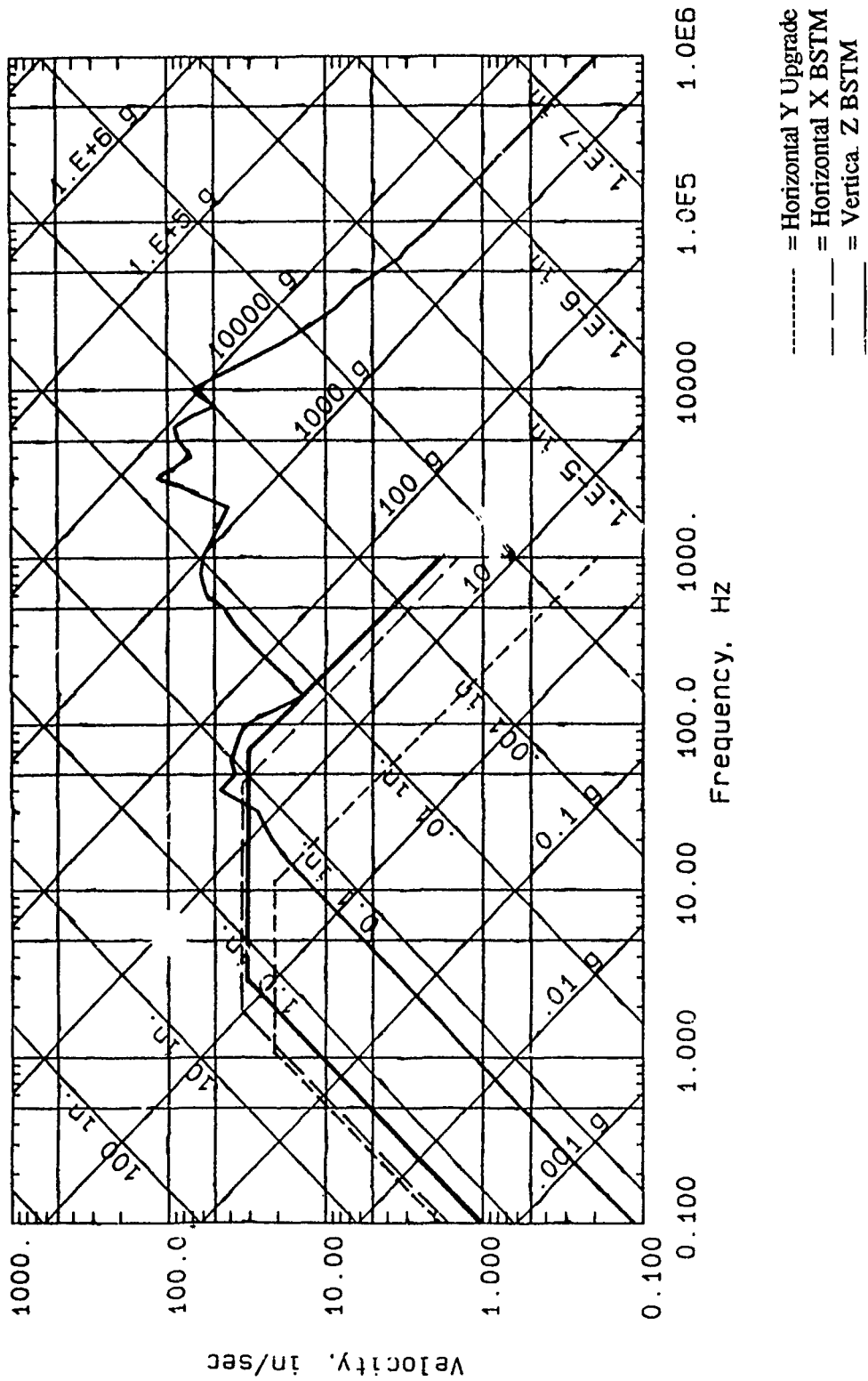

Figure 14. Shock spectra—aboveground detonation, Gage AFY-26, Event 10.

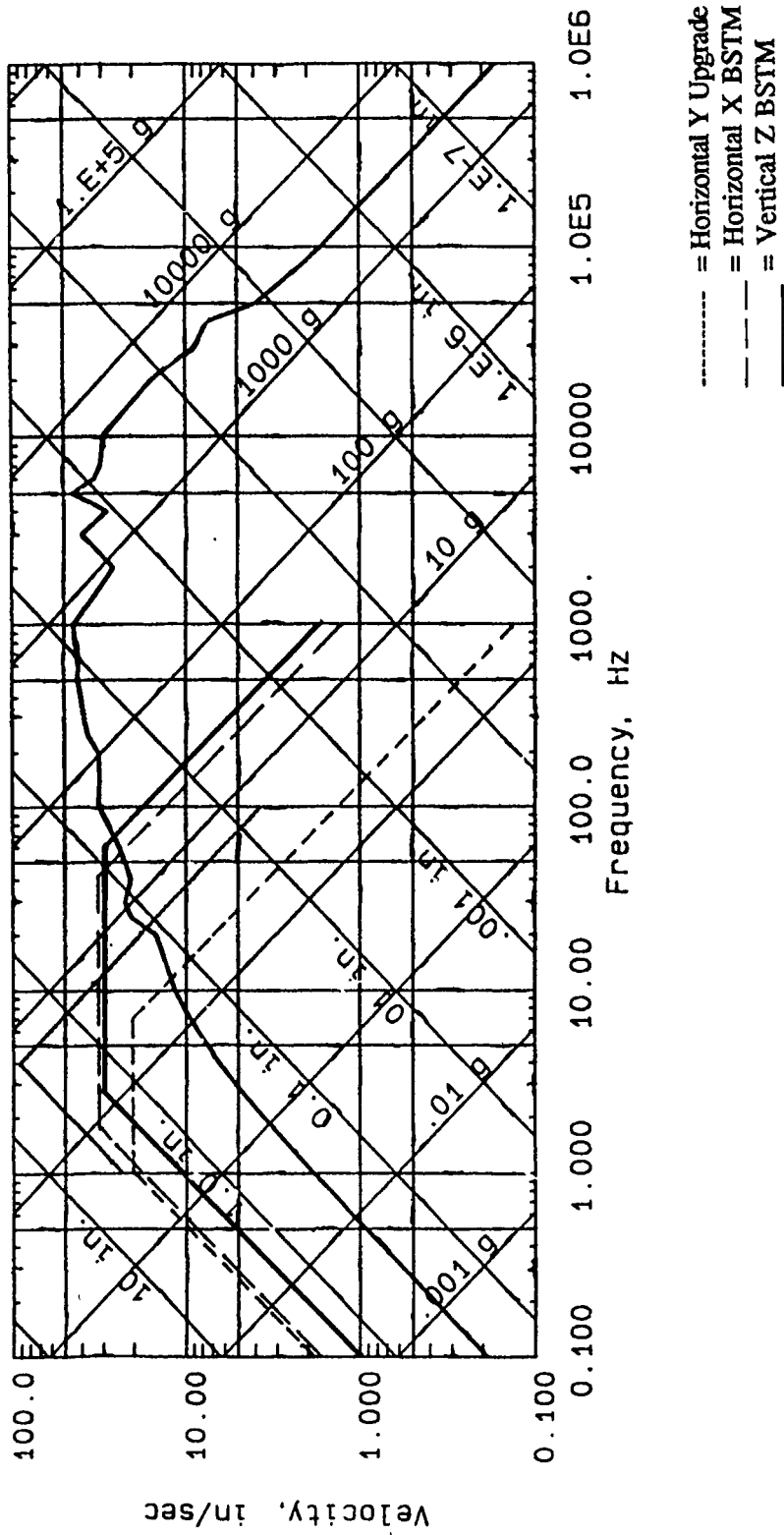

Figure 15. Shock spectra—aboveground detonation, Gage AFY-11, Event 02.

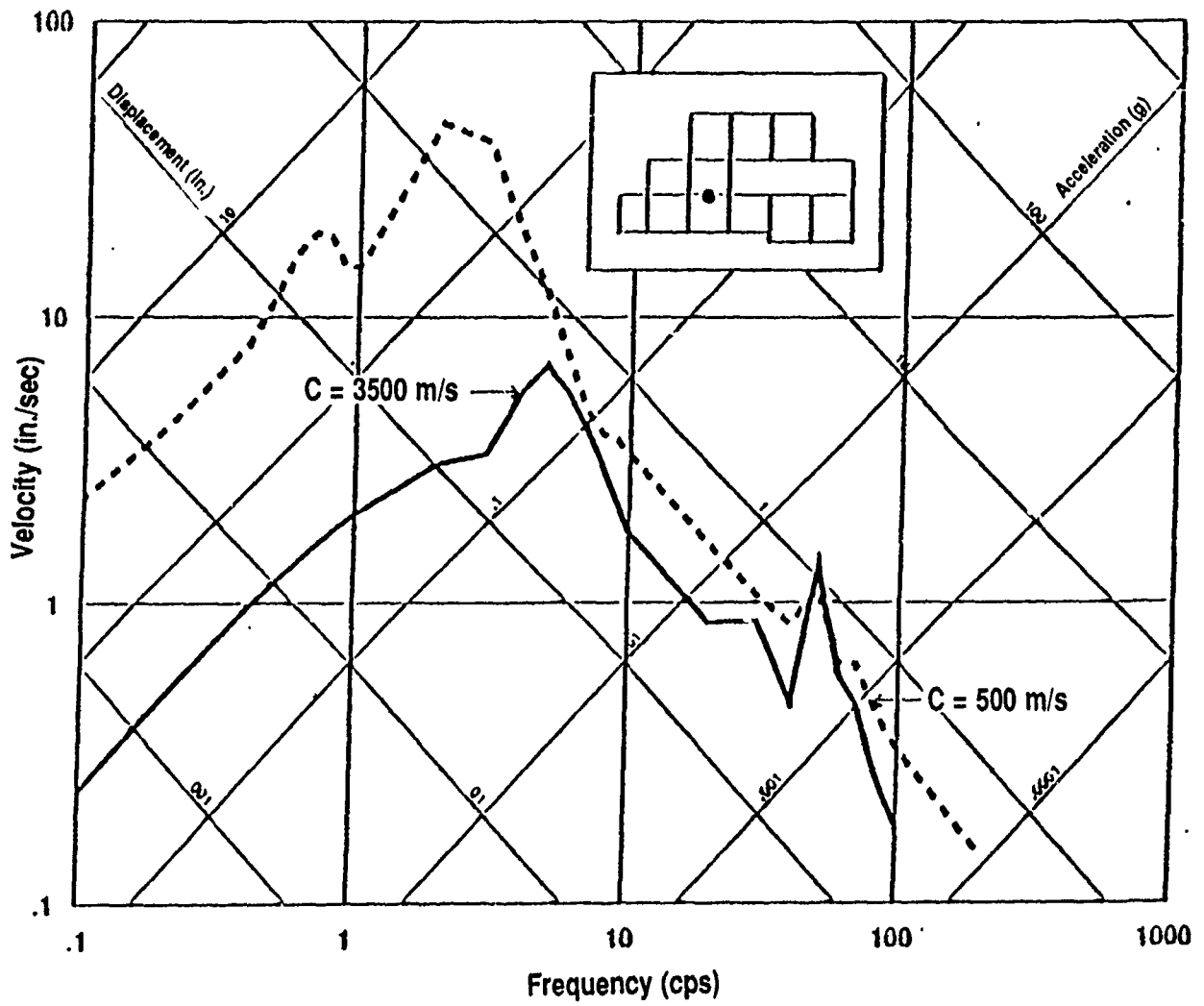

Figure I6. Horizontal in-structure shock spectra.

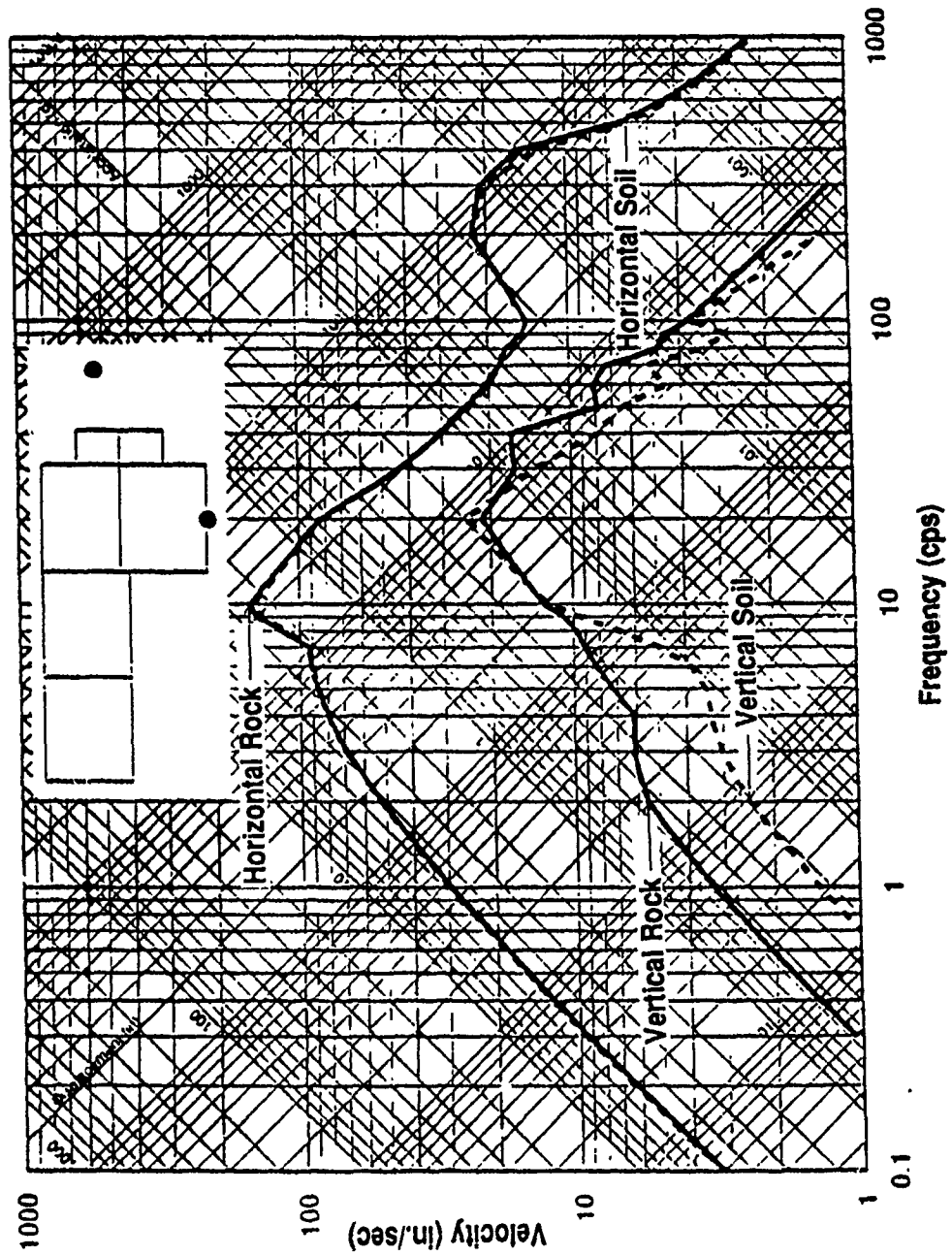

Figure I7. L-shaped structure response spectra.

In-Structure Acceleration

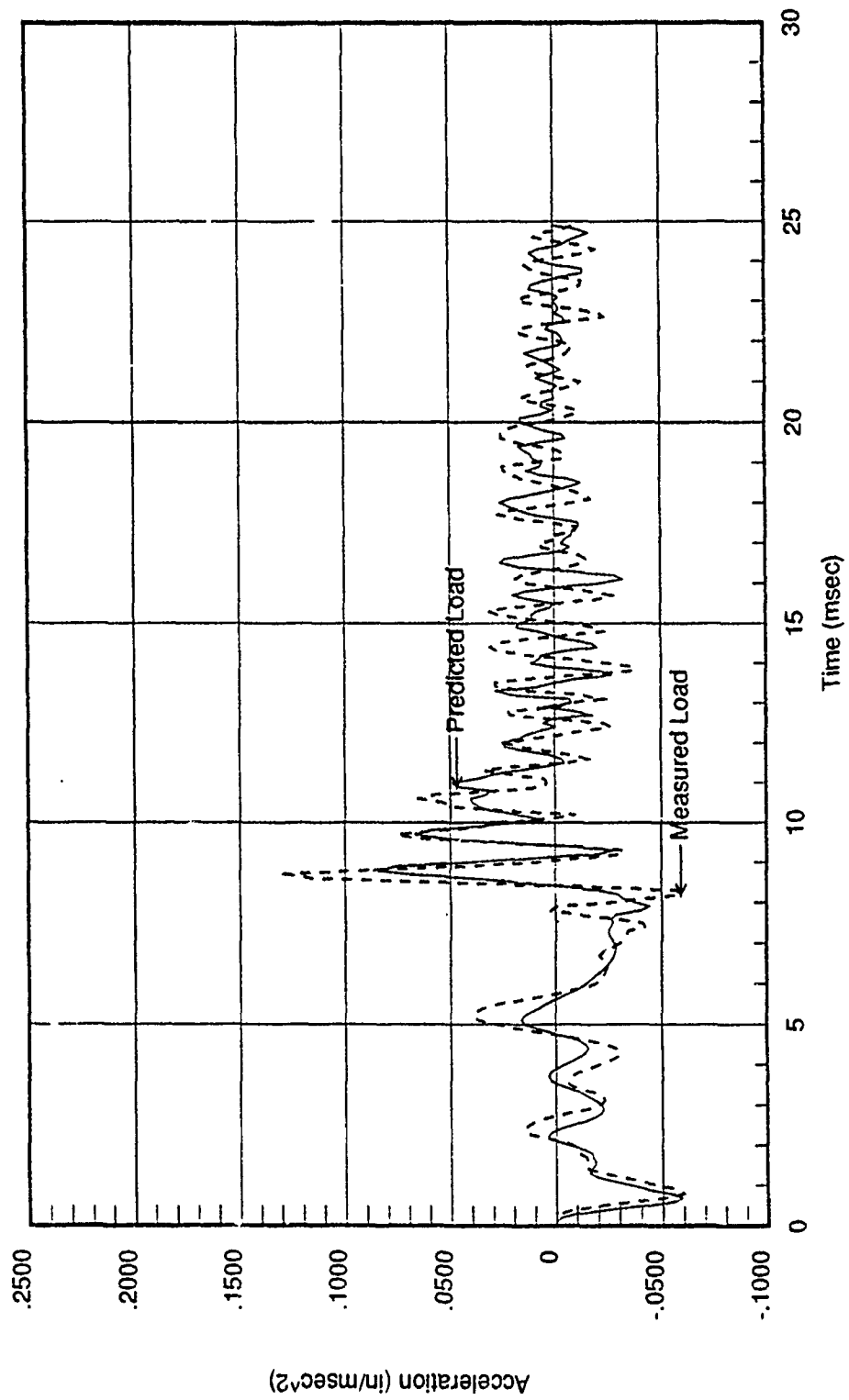

Figure 18. GLCM structure, Test 1.

In-Structure Acceleration

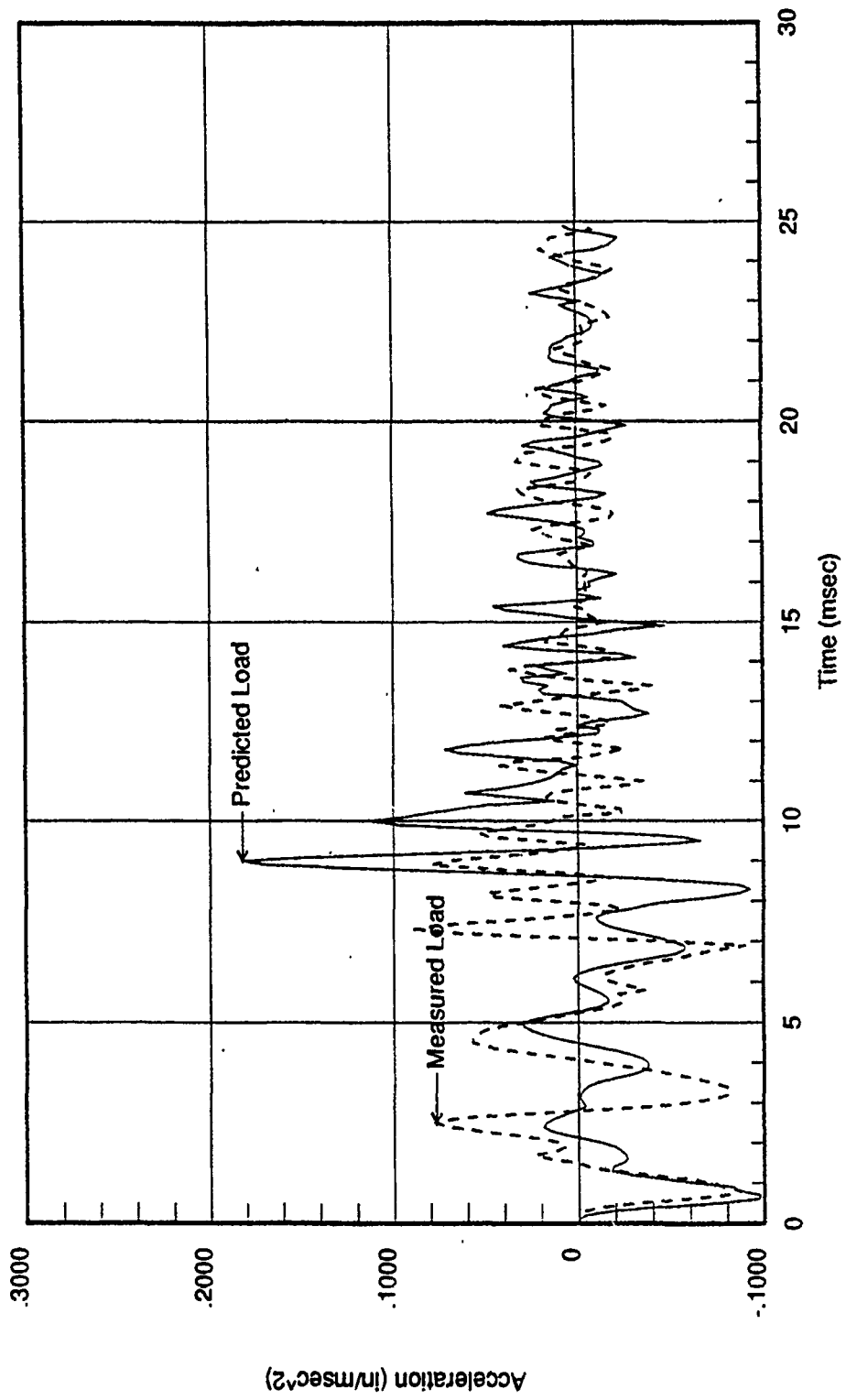

Figure 19. GLCM structure, Test 2.

In-Structure Acceleration - Predicted Load

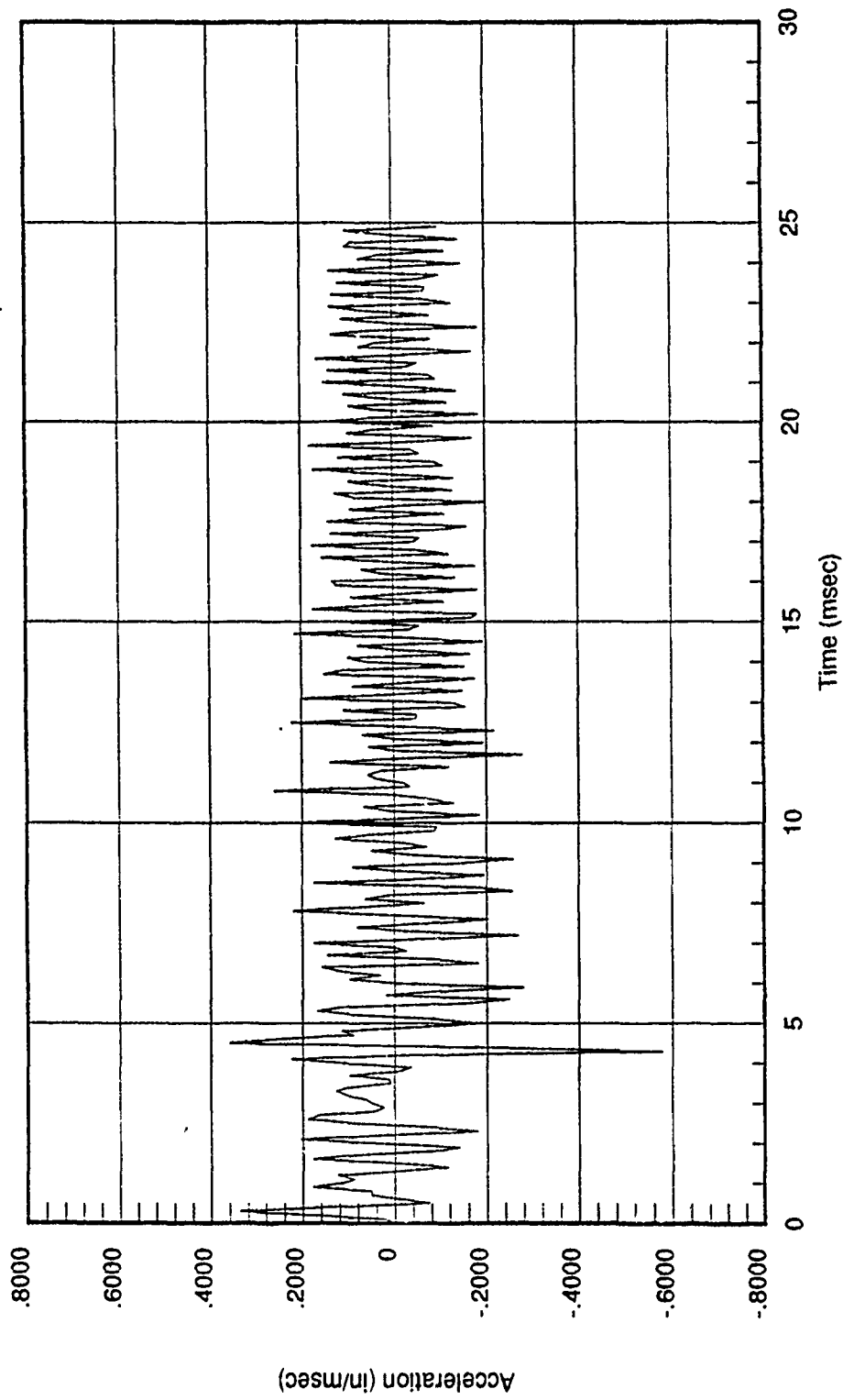

Figure I10. GLCM structure, Test 7b—predicted load.

In-Structure Acceleration - Measured Load

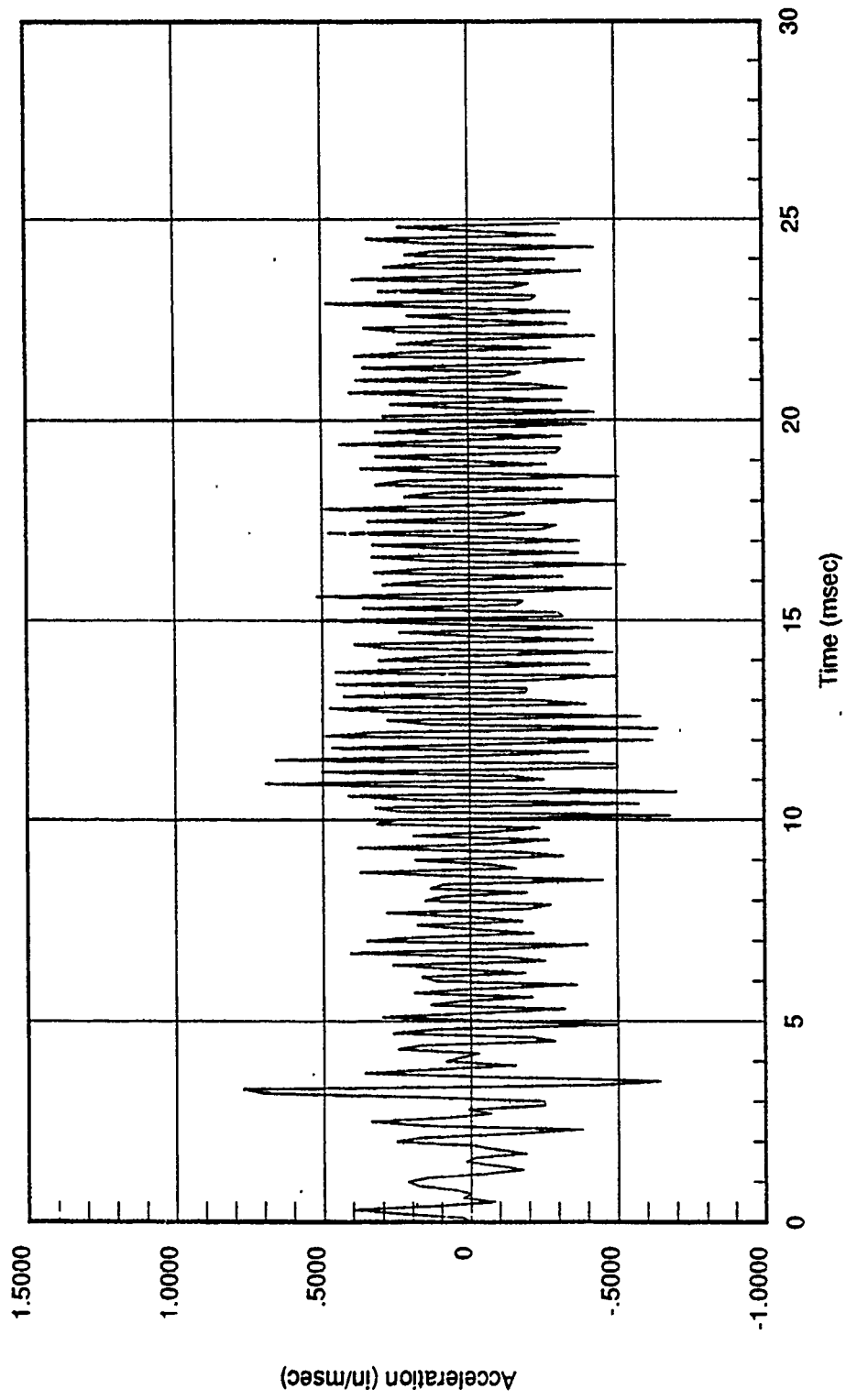

Figure III. GLCM structure, Test 7b—measured load.

IN-STRUCTURE ACCELERATION - NODE 48 - HORIZONTAL

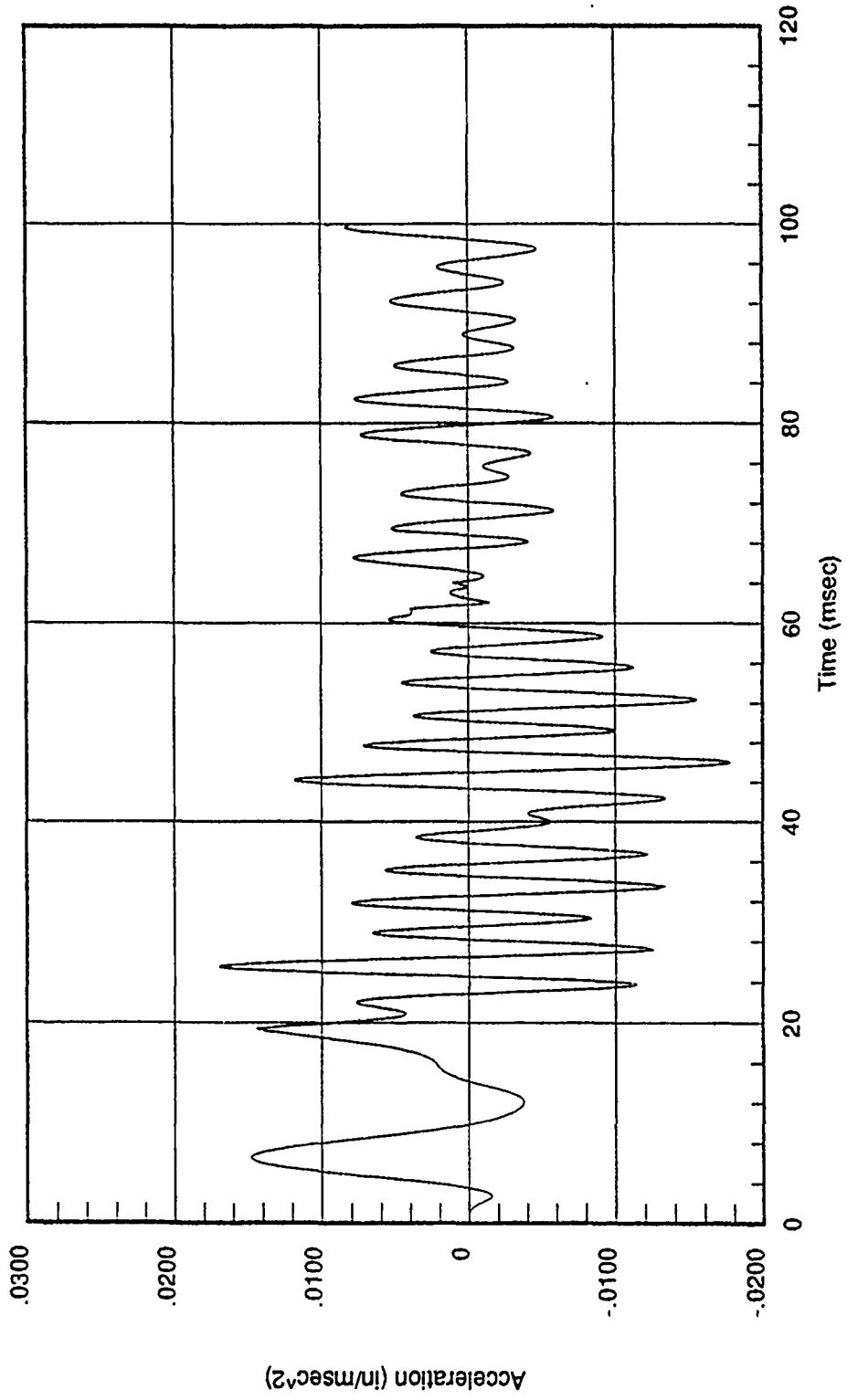

Figure I12. L-shaped structure load, Case 1.

IN-STRUCTURE ACCELERATION - NODE 7 - VERTICAL

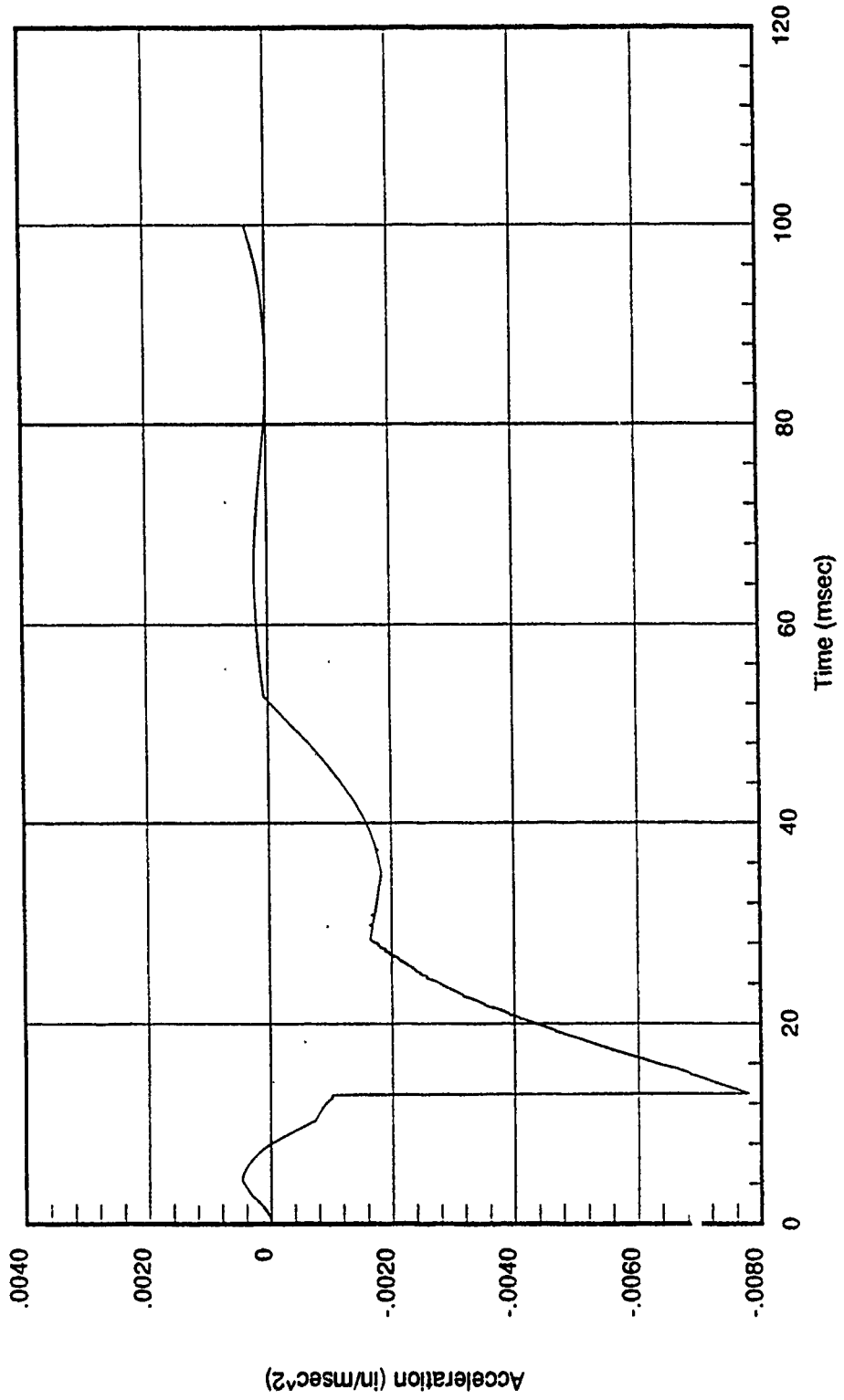

Figure I13. L-shaped structure load, Case 2.

IN-STRUCTURE ACCELERATION - NODE 39 - HORIZONTAL

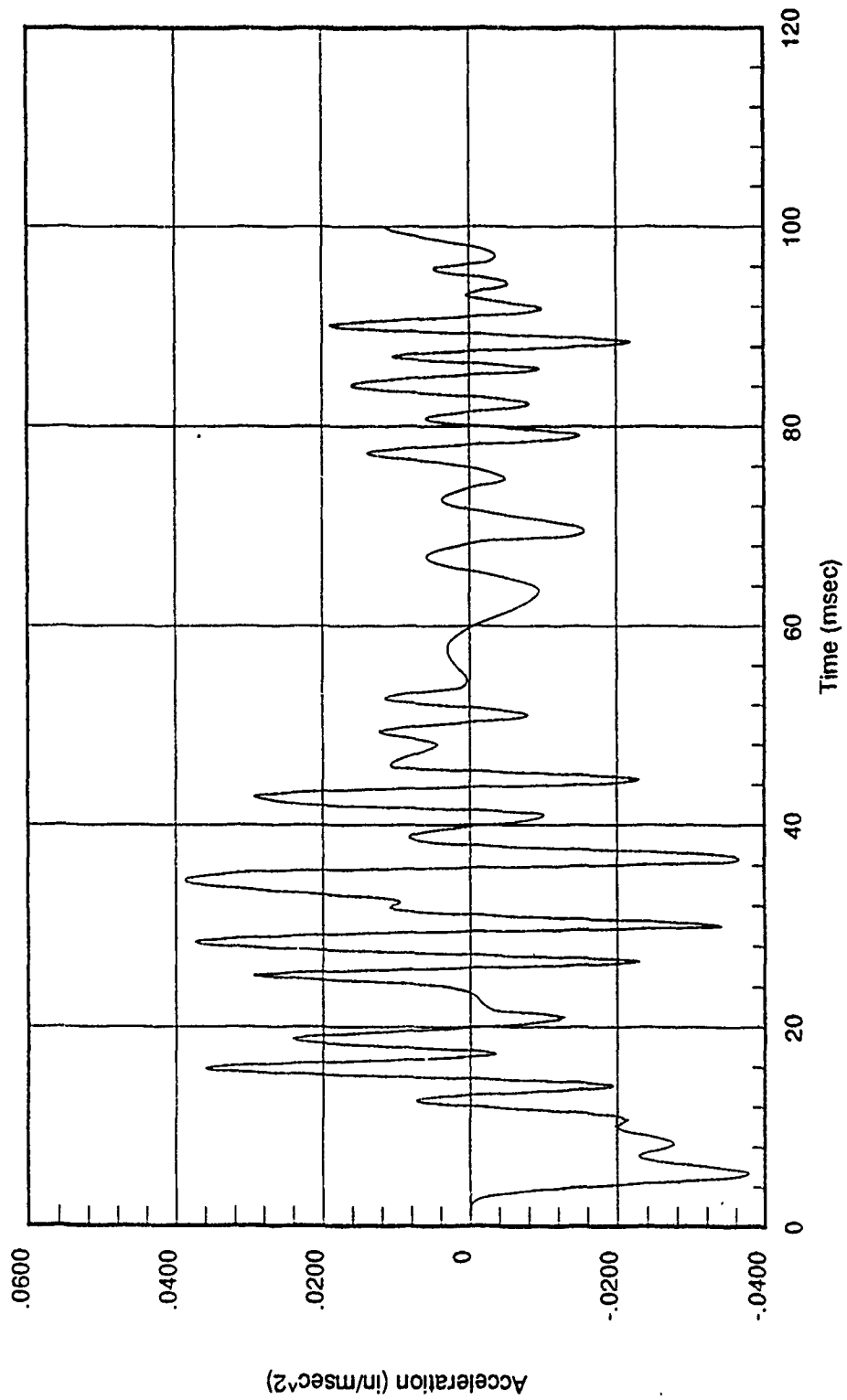

Figure I14. L-shaped structure load, Case 4.

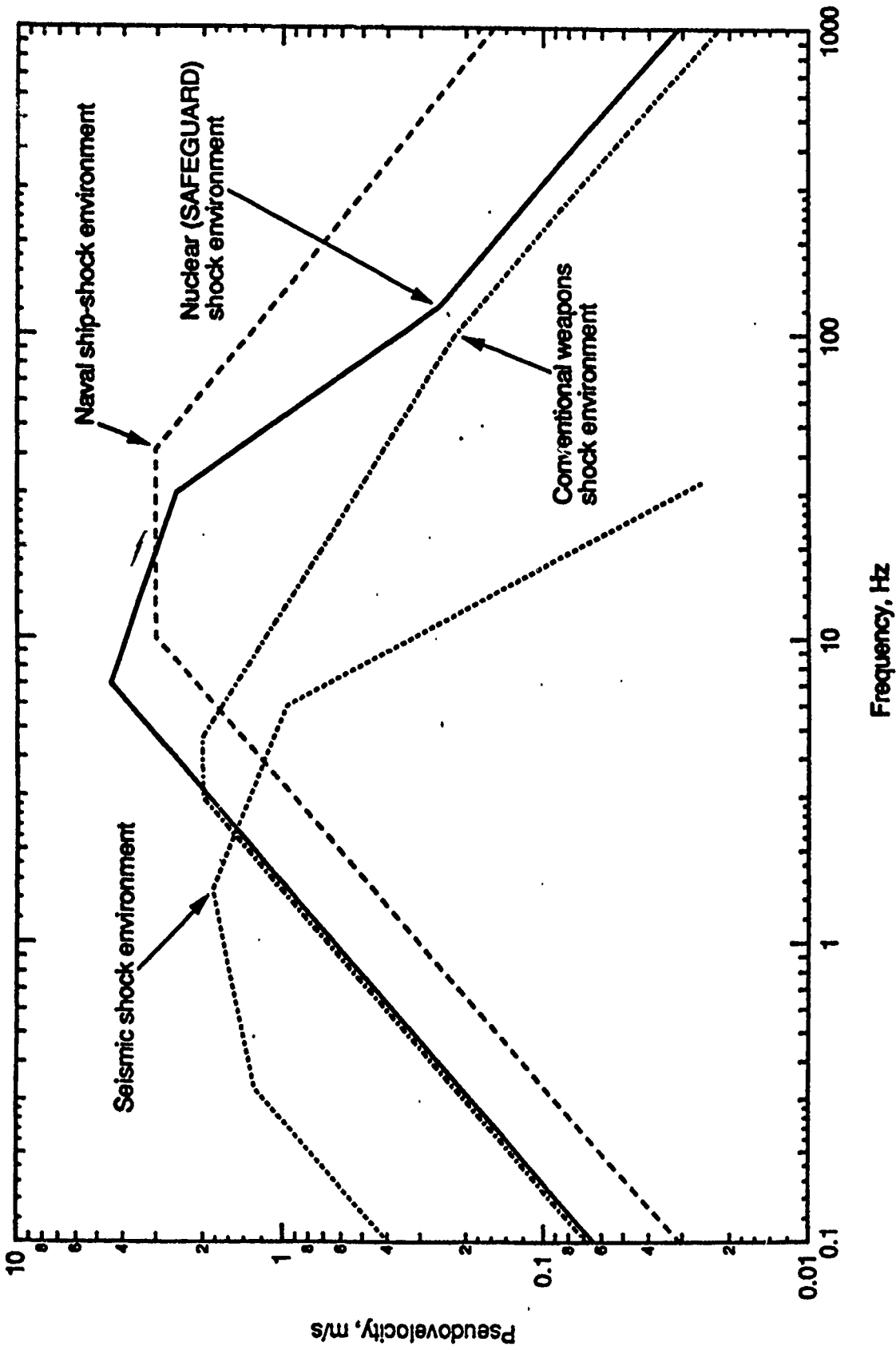

Figure I15. Comparison of the SRS frequency content of different shock environments.

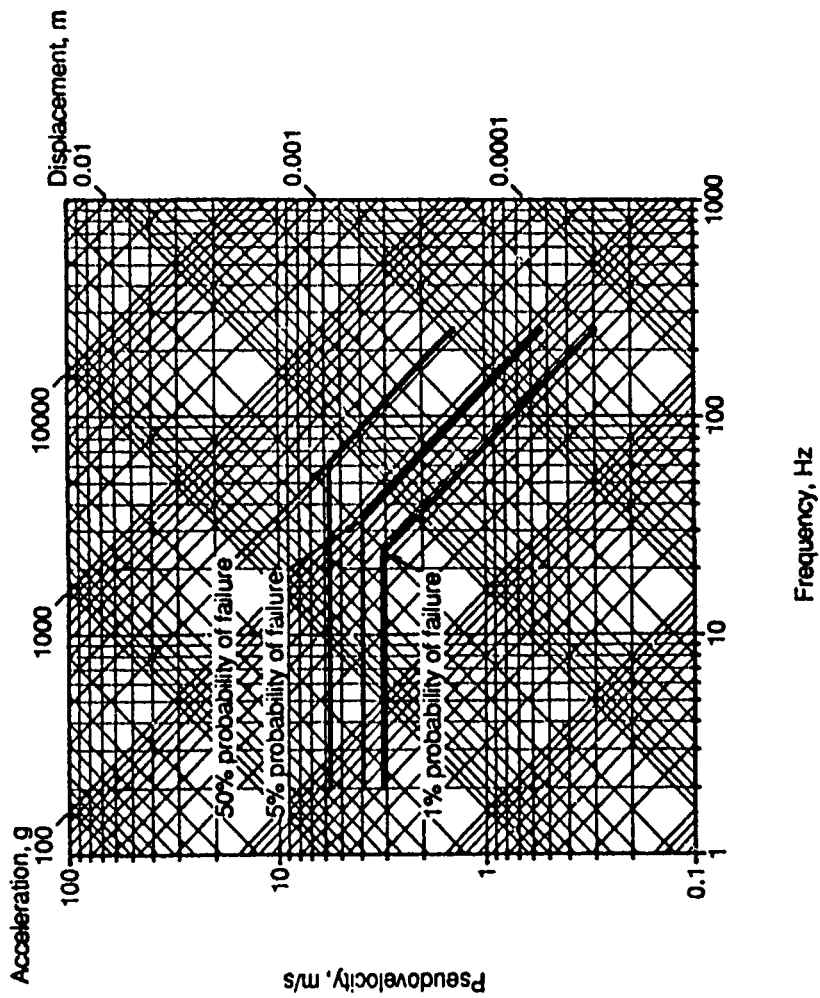
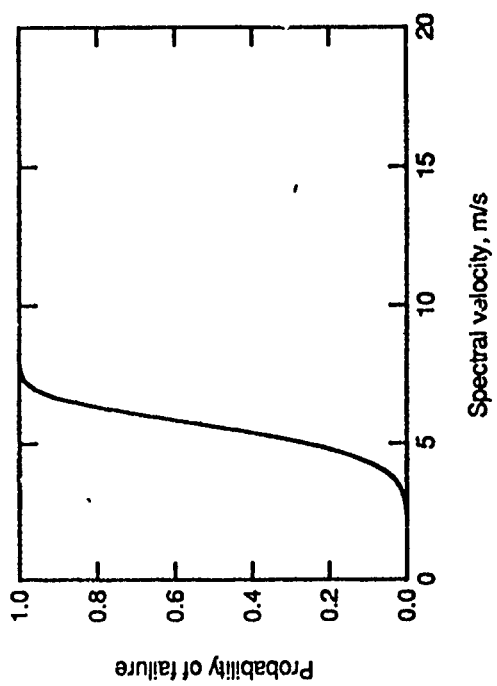
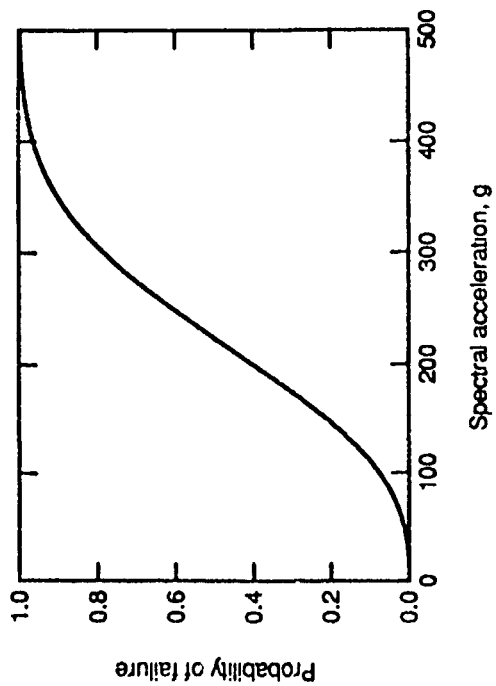

Figure I16. Development of fragility spectra for equipment, Category B.

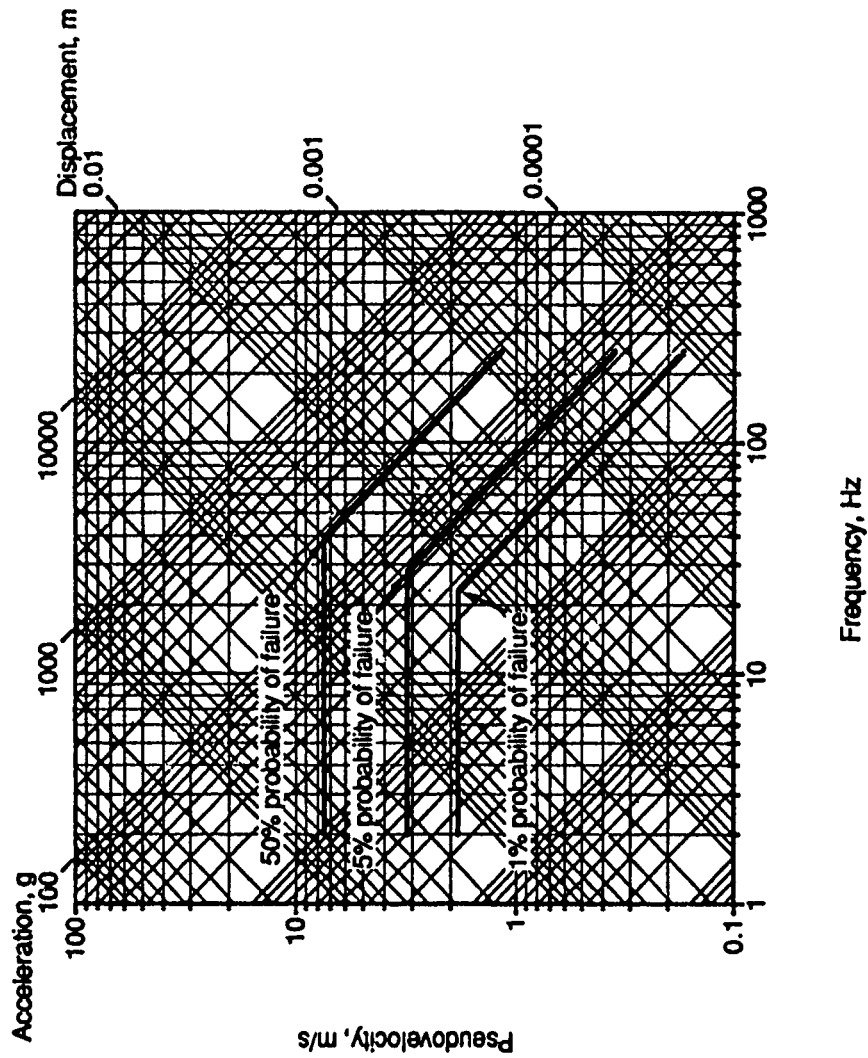
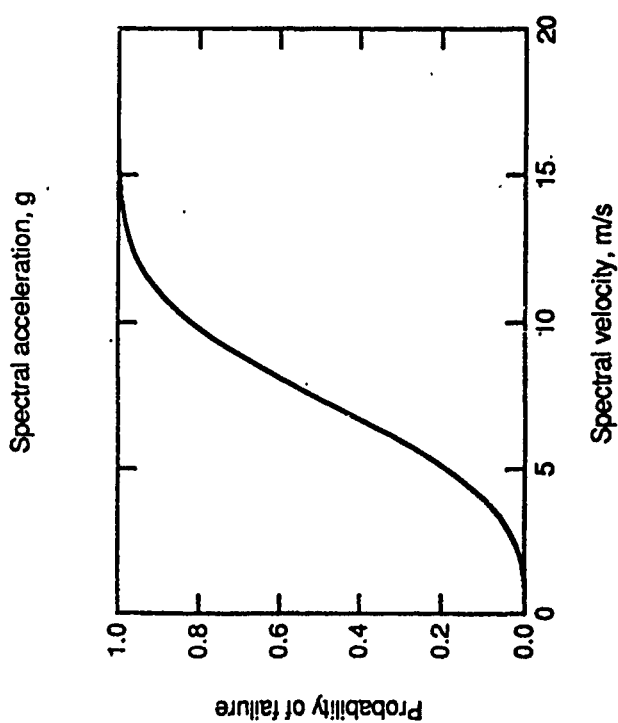
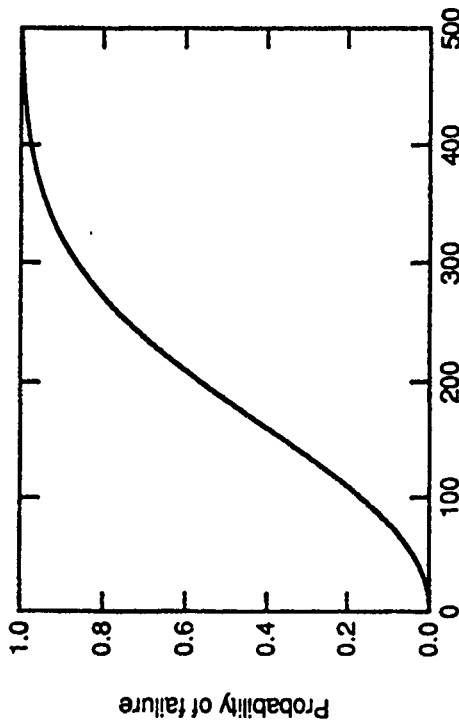

Figure I17. Development of fragility spectra for equipment, Category A.

APPENDIX J: POST-WORKSHOP INPUTS

At the conclusion of the workshop, all panelists were asked to consider the issues they had discussed and provide any additional comments they wished to make via followup letters or telephone calls. A summary of the comments submitted follows.

Mr. James Tanouye, South Pacific Division, U.S. Army Corps of Engineers:

1. USACERL's capabilities with the BSTM are unknown or perceived as poor by many. The staff members are not well known and the BSTM is perceived as being capable of shock testing only.

2. The workshop impressed the attendees because they learned of the BSTM's broad capabilities and solid research record, thus dispelling many of the negative impressions. This indicates a need for marketing activities to dispel unjustified negative perceptions.

3. The workshop discussions suggest a clear course of action:

- a. Maintain both the current seismic and shock test capabilities.
- b. Establish a joint University of Illinois and USACERL research center around the BSTM. Dr. Mete Sozen could potentially be the director of an advisory board for the center.
- c. Pursue an electronic control/data acquisition system upgrade now.
- d. Create a research track record.
- e. Prepare a brochure for public distribution.
- f. "Evangelize" the BSTM "a la WES."
- g. Pursue triaxial upgrade.

Dr. Sam A. Kiger, West Virginia University:

1. The BSTM is a national asset that is very much underutilized.

2. Any research related to weapons-effect shock is most likely to be DOD-funded. The study of in-structure shock effects on structural elements will probably not be funded because other methods are more effective than shake table tests. However, the BSTM has great potential for equipment fragility and shock isolation system testing. Recent conventional-weapons-effects tests have shown the need for updated data.

3. The BSTM appears to have been used very little for seismic research. It is unlikely that large sums of Corps of Engineers research funds will be available for seismic research since most Corps seismic research is in the civil works arena, a USAWES mission area. It is unrealistic to anticipate that USAWES researchers will want to use the USACERL BSTM. USACERL should broaden its seismic research base by attracting researchers from other institutions who could independently develop research programs using the BSTM. Perhaps these researchers could be invited for short stays at USACERL to become familiar with the BSTM. They could subsequently develop joint research proposals for the BSTM.

Dr. Cornelius J. Higgins, Applied Research Associates:

1. It is wrong to compare response spectra from measured motions in structures to the BSTM performance envelope. Response spectra define system responses to base motions; responses in the intermediate to high frequency ranges are amplified over base motions. The BSTM performance envelope really represents base motion, so a comparison of the BSTM performance envelope to typical response spectra provides a distorted, unfair view of the BSTM's capabilities. Rather, structural base motions should be used for comparisons to BSTM performance.

2. Increased stroke does not seem to be the major factor that many workshop panelists made it to be. Almost all experimental work would likely be at a reduced geometric scale, and displacements scale linearly with the geometric scale factor. For example, in a quarter-scale test, the BSTM's 5.5-in. stroke models a 22-in. displacement.

3. The BSTM is very capable now, should be employed, and is worthy of an upgrade. It needs more effective marketing and participation by both USACERL and the University of Illinois.

Mr. William Flathau, JAYCOR:

1. The BSTM as it now exists is a powerful tool for shock testing. It is not well publicized.

2. The BSTM should be marketed as a national facility. A close and visible partnership with the University of Illinois will be most important in any such effort.

3. There are means other than spectral graphs to portray the BSTM's capabilities. These might be used to supplement spectral ordinate plots.

Mr. William Gaube, Protective Design Center, Omaha District, U.S. Army Corps of Engineers:

1. The in-structure shock panelists were decidedly mixed in their opinions on the advisability of the triaxial upgrade.

2. The in-structure shock panelists tended to favor obtaining higher acceleration capabilities, approaching 100 g, for the BSTM, but this was not a strong sentiment. The AFWL data indicate that most equipment fragility testing could be done within the BSTM's performance envelope of 30g to 60g. For higher acceleration levels, explosive or mechanical shear devices would probably be required.

3. Increased BSTM stroke capability for lower frequency testing is a desirable performance characteristic.

4. The current BSTM capability is adequate for much testing in the shock arena. The payload capacities are sufficient for most shock isolation and equipment vulnerability testing.

5. USACERL should submit Corps of Engineers sustaining research funding work units for the BSTM. This would probably help stimulate support from other organizations.

6. Overall upgrade priorities should be:

- a. Increased specimen preparation space and office space, including a secure area
- b. New table controls
- c. Triaxial motion capability
- d. Increased stroke
- e. Improved on-site consulting services.

ABBREVIATIONS

AFWL	Air Force Weapons Laboratory
AWACS	Airborne Warning and Control System
BSTM	Biaxial Shock Test Machine
DOD	Department of Defense
EM	Engineering and Materials Division, USACERL
EN	Environmental Division, USACERL
ESS	earthquake simulation system
FCDNA	Field Command, Defense Nuclear Agency
gpm	gallons per minute
HQ AFESC	Headquarters, Air Force Engineering Services Center
HQUSACE	Headquarters, U.S. Army Corps of Engineers
ips	inches per second
kN	kiloNewton
kN-m	kiloNewton-meter
kip	kilopounds
NCEER	National Center for Earthquake Engineering Research
NIST	National Institute of Standards and Technology
NSF	National Science Foundation
OSD-PIF	Office of the Secretary of Defense Product Improvement Fund
psi	pounds per square inch
RDTE	Research, Development, Testing, and Evaluation
SEPS	Structural Engineering and Physical Security
SUNY	State University of New York
UC	University of California
UIUC	University of Illinois at Urbana-Champaign
USACE	U.S. Army Corps of Engineers
USACERL	U.S. Army Construction Engineering Research Laboratory
USAWES	U.S. Army Waterways Experiment Station