

AD-A237 467



REPORT DOCUMENTATION PAGE

HC
CTE
D
C
MAY 01 1991

1b. RESTRICTIVE MARKINGS
N/A

3. DISTRIBUTION / AVAILABILITY OF REPORT
Approved for public release;
distribution unlimited.

4. PERFORMING ORGANIZATION REPORT NUMBER(S)
N00014-89-J-1314-12

5. MONITORING ORGANIZATION REPORT NUMBER(S)

5a. NAME OF PERFORMING ORGANIZATION
LASST
University of Maine

6b. OFFICE SYMBOL
(if applicable)

7a. NAME OF MONITORING ORGANIZATION
Office of Naval Research
Branch Office Chicago

6c. ADDRESS (City, State, and ZIP Code)
Sawyer Research Center
Orono, ME 04469

7b. ADDRESS (City, State, and ZIP Code)
536 S. Clark Street
Chicago, IL 60605

8a. NAME OF FUNDING / SPONSORING ORGANIZATION
Office of Naval Research--Chemistry Program

8b. OFFICE SYMBOL
(if applicable)

9. PROCUREMENT INSTRUMENT IDENTIFICATION NUMBER
N00014-89-J-1314

8c. ADDRESS (City, State, and ZIP Code)
800 N. Quincy Street
Arlington, VA 22217

10. SOURCE OF FUNDING NUMBERS			
PROGRAM ELEMENT NO.	PROJECT NO.	TASK NO.	WORK UNIT ACCESSION

11. TITLE (Include Security Classification)
Effect of Excess Oxydianiline on the Properties of Polyimide

12. PERSONAL AUTHOR(S)
R. G. Pethe, W. N. Unertl, C. M. Carline

13a. TYPE OF REPORT
Technical

13b. TIME COVERED
FROM 1/6/90 TO 31/5/91

14. DATE OF REPORT (Year, Month, Day)
15 May 1991

15. PAGE COUNT
18

16. SUPPLEMENTARY NOTATION
Submitted to: J. Polymer Science

17. COSATI CODES		
FIELD	GROUP	SUB-GROUP

18. SUBJECT TERMS (Continue on reverse if necessary and identify by block number)
Polyimides, Raman Spectroscopy

19. ABSTRACT (Continue on reverse if necessary and identify by block number)
Thin films of the polymer polyimide (PI) can be grown in ultra-high vacuum by codeposition of pyromellitic dianhydride (PMDA) and oxydianiline (ODA). Raman spectroscopy was used to characterise the effects of non-stoichiometric deposition rates and substrate temperature on the chemical properties of the resulting PI film. Low fluxes and excess PMDA yield PI formation. High fluxes and excess ODA give short chain formation and crosslinking. Dosing onto heated substrates does not yield PI for high fluxes or excess PMDA thus ruling out the possibility of a one step process for PI formation.

20. DISTRIBUTION / AVAILABILITY OF ABSTRACT
 UNCLASSIFIED/UNLIMITED SAME AS RPT. DTIC USERS

21. ABSTRACT SECURITY CLASSIFICATION
unclassified

22a. NAME OF RESPONSIBLE INDIVIDUAL
William N. Unertl

22b. TELEPHONE (Include Area Code)
207-581-2251

22c. OFFICE SYMBOL

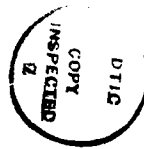

Accession For	
DTIC GRAAL <input checked="" type="checkbox"/>	
DTIC TAB	
Unannounced	
Justification	
By _____	
Distribution/	
Availability Codes	
Dist	Avail and/or Special
A-1	

EFFECT OF EXCESS OXYDIANILINE ON THE PROPERTIES OF POLYIMIDE ^v

BY R. G. PETHE, W. N. UNERTL, C. M. CARLIN*

DEPT. OF PHYSICS AND ASTRONOMY

AND

LABORATORY FOR SURFACE SCIENCE AND TECHNOLOGY

UNIVERSITY OF MAINE

ORONO, MAINE 04469

AND

* DEPT. OF CHEMISTRY

UNIVERSITY OF NORTH CAROLINA AT CHARLOTTE

CHARLOTTE, NORTH CAROLINA 28223

* work supported by a grant from the
Office of Naval Research;

91-03747



INTRODUCTION

This letter reports the properties of defects that develop during processing of the polymer polyimide. Such defects can adversely alter the dielectric and adhesive properties of polyimide films which are widely used, for example in the semiconductor industry as interlevel dielectrics. Polyimide films can be cast or spin coated from solution or formed by direct vapor deposition which is the subject of this letter. Vapor deposition of thin polyimide films was first demonstrated by Salem et al. [1] and by Takahashi et al. [2]. It has advantages over solvent based techniques including elimination of deleterious interactions between the substrate and solvent.

The basic reaction of the vapor deposition process is shown in fig. 1. The monomers pyromellitic dianhydride (PMDA) and 4,4'-oxydianiline (ODA) are co-deposited onto the substrate where they react to form the intermediate polyamic acid (PAA). Upon heating PAA is converted to polyimide with the release of water. Salem et al. [1], and subsequent workers [3, 4], have emphasized that the properties of polyimide films formed from vapor deposition can be influenced by the presence of various types of defects that can form during both deposition and curing. These defects may be due to trapped monomers, trapped polyamic acid, branching and crosslinking, isoimide or imine bond formation or both.

This letter reports the effects of excess ODA on vapor

deposition polymerization as determined by Raman spectroscopy. Results for excess PMDA will be reported separately [5]. Excess ODA causes short chain structures interlinked through imine bonds. These structures are less thermally stable than pure polyimide. The implications of these results on other processing methods are discussed.

EXPERIMENTAL DETAILS

The experiments were carried out in a turbo molecular pumped ultra high vacuum system capable of base pressures of 1×10^{-9} torr. This vacuum system has two connected chambers: (1) a chamber for vapor deposition and (2) a chamber for in-situ Raman analysis.

The precursors, PMDA and ODA are loaded into separate Knudsen cells with 100 micron apertures. Each Knudsen cell is separately heated and the relative fluxes were calibrated using quartz crystal microbalances. The ratio of ODA-to-PMDA can be varied between 15:1 and 1:15. The results reported in this letter emphasize the 15:1 excess ODA dose. The substrate was a 0.076 mm thick Ag foil (99.97% purity, Alpha Products) and was cleaned using argon ion sputtering. The sample temperature could be varied between 140 K and 750 K. The substrate was not heated during deposition but proximity to the ovens caused about a 1 K rise above room temperature.

Raman spectra were obtained using 457.9 nm laser radiation

(Spectra Physics model 2020) with source power at 80 mW and a holographic grating double monochromator (Instruments SA, model H6-2000) with a cooled photomultiplier tube. A prism monochromator and an interference filter were used to eliminate plasma lines. The strong luminescence of the samples prevented acquisition of spectra for wavenumbers greater than about 1800 cm^{-1} . Thus it was not possible to obtain information about the N-H and C-H stretching vibrations. Raman spectra were obtained from the as deposited films and following cures at 473 K for 30 min and 1 hour, and 573 K for 30 min, 1 hr and 2 hr. Assignments for all peaks are given in table I and are consistent with those reported in the literature [6] except where specifically mentioned below. Data collection times were typically about 8 hours. No evidence is seen for sample degradation caused by the laser beam.

Raman spectra have also been collected for bulk PMDA and ODA, Kapton film, and stoichiometric PMDA-ODA polyimide and were used for reference. Unpublished data [7] on model compounds and on bulk samples containing excess ODA have also been used as reference spectra.

RESULTS

The 1:1 as deposited film shows major bands at 1350 cm^{-1} and 1605 cm^{-1} with a strong shoulder at 1550 cm^{-1} . The 1605 cm^{-1} structure is due to the ODA and PMDA ring modes; the shoulder at 1550 cm^{-1} to the amide groups; the band at 1350 cm^{-1} to the C-N

stretching vibrations. The Raman spectra for the as deposited films with 15:1 ratio of ODA-to-PMDA shows very strong luminescence and consequently it is difficult to acquire spectra with high signal to noise ratio. ODA derived bands (1160 cm^{-1} , 1200 cm^{-1} , 1274 cm^{-1}) for the 15:1 sample are only barely observable above the noise level; i.e. their relative intensities are comparable to those in the 1:1 film. This implies that a large fraction of the incident ODA is not retained in the film. At most, only eight ODA molecules could react with each PMDA molecule; e.g. with every carbonyl oxygen displaced by an imine group and each anhydride oxygen replaced by two amide bonds.

Curing at 473 K for 30 min reduces the luminescence and results in a Raman spectrum very similar to that for stoichiometric polyimide (figs 2a and 2b). Both the stoichiometric PI film and the 15:1 excess ODA film have common features at 1130 cm^{-1} , 1160 cm^{-1} , 1250 cm^{-1} , 1400 cm^{-1} , 1515 cm^{-1} and 1790 cm^{-1} ; these are derived from the ODA and PMDA units in polyimide. Both films show shoulders at about 1550 cm^{-1} and 1660 cm^{-1} that are not seen in model compounds studied by Ishida et al. [6]. The assignments of these features is given in table I. Curing also shifts the amide C-N stretching mode from 1350 cm^{-1} to 1400 cm^{-1} due to ring closure to form the imide. The origin of the band at 1460 cm^{-1} observed for both 15:1 and 1:1 films is not known. This band has also been observed by Perry and Campion [8] for an as deposited film at 140 K and in model compounds [7]. The carbonyl (C=O) symmetric stretch at 1790 cm^{-1} , which is very weak in PAA, is characteristic of both

PMDA and polyimide. Both films show a weak shoulder at 1550 cm^{-1} characteristic of PAA. There are two major differences between the spectra. One is that the ODA/PMDA ring modes occur at about 1615 cm^{-1} for the stoichiometric film but at 1605 cm^{-1} for the 15:1 film. The second is that, for the stoichiometric film, the 1400 cm^{-1} band due to the imide group C-N stretch is relatively more intense with respect to the 1615 cm^{-1} band.

Curing of both films for another 60 min at 473 K causes no further significant changes. However, curing at higher temperatures (573 K for 30 min) causes important additional changes in the 15:1 film but has little effect on the 1:1 film (fig 3b and 3a). The 15:1 film shows a strong increase in the intensity of the bands at 1660 cm^{-1} and 1750 cm^{-1} . Isoimides show a strong peak at 1700 cm^{-1} and do not show any structure at 1660 cm^{-1} [7] and therefore can be ruled out as a possible explanation. However, similar bands have been observed for bulk samples of model compounds with excess ODA [7]. In particular, these model compounds show distinctive Raman bands with the same wavenumbers and relative intensities. Both Raman and FTIR results were used to assign the 1660 cm^{-1} band to imine groups (C=N) (see fig 4) and the 1750 cm^{-1} band the symmetric carbonyl stretch which is shifted from its value at 1790 cm^{-1} in polyimide. These similarities with our data lead us to conclude that curing the 15:1 film causes formation of imine groups. The proximity of the imine and imide groups should cause a shift of the imide group C-N stretch from 1400 cm^{-1} to a lower wavenumber. This occurs for the 15:1 film as evidenced

by the relative decrease in the intensity and asymmetric broadening of the 1400 cm^{-1} towards lower wavenumbers. Fitting this band with two Gaussians functions yielded a shifted C-N stretch band at about 1390 cm^{-1} plus the unshifted band at 1400 cm^{-1} . The intensity of the shifted band increases with increasing curing time while the 1400 cm^{-1} decreases. The simultaneous growth of the 1390 cm^{-1} , 1660 cm^{-1} and 1750 cm^{-1} bands, plus the weakening and broadening of the 1400 cm^{-1} band for cures up to 90 min all indicate that the number of imine bonds increases. Longer cures show a reverse effect, in addition to the gradual disappearance of the 1130 cm^{-1} and 1790 cm^{-1} bands (fig 5a and 5b), implying that the number of imine bonds reaches a maximum after about a 90 min cure at 573 K.

Increasing the curing temperature to 623 K results in the rapid decomposition of the 15:1 film. This is apparent in fig 6 which shows a Raman spectrum obtained after heating for 30 min at 623 K. In contrast, a 1:1 film shows no change at all after similar heat treatment. Clearly the 15:1 film has much less thermal stability than pure polyimide.

DISCUSSION

The experiments show that excess ODA has significant effects on the formation and stability of ODA-PMDA polyimide films formed by vapor deposition. In particular, imine bonds are formed. At curing temperatures up to 473 K, the fraction of imine bonds is small and the film has vibrational spectra of predominantly

polyimide character. Heating at temperatures up to 573 K increases the number of imine bonds. The changes caused by excess ODA lower the temperature at which the polyimide film decomposes.

The following mechanism is consistent with these observations. First, we expect excess ODA will lead to the formation of short chain structures of the form $(OP)_nO$, where the O and P stand for ODA and PMDA units respectively and n is a small integer (e.g. 1, 2, 3), after a cure at temperatures of at least 423 K. Similar structures are formed in solution with excess ODA [7]. The majority of the excess ODA evaporates but small quantities may still be trapped.

Curing at 473 K primarily forms imide linkages in the normal way (see fig 1), but some imine bonds are also created (see fig 4), for both excess ODA and stoichiometric doses. Additional trapped ODA, from the excess ODA doses, may be lost at this stage.

Heating to higher temperatures (573 K) causes a rapid increase in the number of imine bonds. This can happen either by reaction between trapped ODA molecules and carbonyl groups on the $(OP)_nO$ chains or by insertion of an NH_2 endgroup of one $(OP)_nO$ chain at a carbonyl group of another $(OP)_nO$ chain. These reactions also form water which evaporates. The imine groups have lower thermal stability than the imide groups. This causes decomposition to occur at a substantially lower temperature than for pure ODA-PMDA polyimide. For a 15:1 film the excess ODA is large enough that a

large fraction of the imide linkages in the $(OP)_nO$ chains are affected by imine formation. Thus, following decomposition at 623 K, fig 6, the Raman spectra show no evidence of pure polyimide which is stable at 673 K.

The weak shoulder seen at 1660 cm^{-1} in stoichiometric polyimide films, fig 2(a), can be assigned to imine bonds formed by the random attachment of trapped ODA molecules or NH_2 terminal groups at carbonyl group sites of the polyimide chains. In this case the fraction of imine bonds is low and each is a point defect that decomposes at higher temperatures. This type of defect is also expected to occur in high molecular weight spin coated and commercial films whenever ODA units terminate the polymer chain. We also note that imine bonds can account for the low binding energy shoulder often observed for the N 1s emission by X-ray photoelectron spectroscopy [4].

In summary, we have shown that excess ODA leads to low molecular weights in vapor deposited polyimide films and that these films have reduced thermal stability due the presence of imine groups. These results show that high quality polyimide can be formed by vapor deposition only if excess ODA is avoided.

REFERENCES

- (1) J. R. Salem, F.A. Sequeda, J. Duran, D.Y. Lee and R. M. Yang, J. Vac. Sci. Technol., A 4, 369 (1986)

- (2) Y. Takahashi, M. Iijima, K. Inagawa and A. Itoh, J. Vac. Sci. Technol., A 5, 2253 (1987)
- (3) R. G. Mack, H. H. Patterson, M. R. Cook, C. M. Carlin, J. Polymer Sci. Lett., 27, 25 (1989)
- (4) R. N. Lamb, J. Baxter, M. Grunze, C. W. Kong and W. N. Unertl, Langmuir, 4, 249 (1988)
- (5) R. G. Pethe and W. N. Unertl, to be published.
- (6) H. Ishida, S. T. Wellinghoff, E. Baer, J. L. Koenig, Macromolecules, 13, 834 (1980)
- (7) Private communication from A. Saini, H. H. Patterson, Dept. of Chemistry, Univ. of Maine
- (8) S. Perry, A. Champion, Surf. Sci. Lett., 234, L275-L280 (1990)

LIST OF TABLES AND FIGURES

1. Table I - Cumulative table showing peak assignments
2. Fig 1 - Reaction mechanism showing ODA-PMDA polyimide formation
3. Fig 2 - Raman spectra of (a) 1:1 vapor deposited polyimide and (b) 15:1 excess ODA dose films cured at 473 K for 30 min
4. Fig 3 - Raman spectra of (a) 1:1 vapor deposited and (b) 15:1 excess ODA films after curing at 573 K for 30 min
5. Fig 4 - Reaction mechanism for the formation of imine interlinks
6. Fig 5 - Raman spectra of the 15:1 excess ODA sample cured at 573 K for (a) 30 min and (b) 2 hours
7. Fig 6 - Raman spectra of the 15:1 excess ODA film after curing at 623 K for 30 min

TABLE I

A cumulative table for peak assignments

Wavenumber (cm^{-1})	Mode	Unit
1128-1132	(OC) ₂ NC	Imide group
1160-1165	C-H stretch	ODA and PMDA
1240-1250	C-O-C stretch	ODA unit forming imide group
1280-1285	C-O-C stretch	ODA unit forming imine link
1387-1390	C-N stretch	Imide group; after forming imine interlinks
1398-1404	C-N	Imide group (OC) ₂ NC
1456-1460	Unknown	
1512-1517	Ring mode	PMDA
1600-1608	Ring mode	ODA and PMDA
1658-1662	C=N stretch	Imine group
1745-1755	C=O stretch	Carbonyl group opposite imine group
1788-1792	C=O stretch	Carbonyl group without imine interlinks

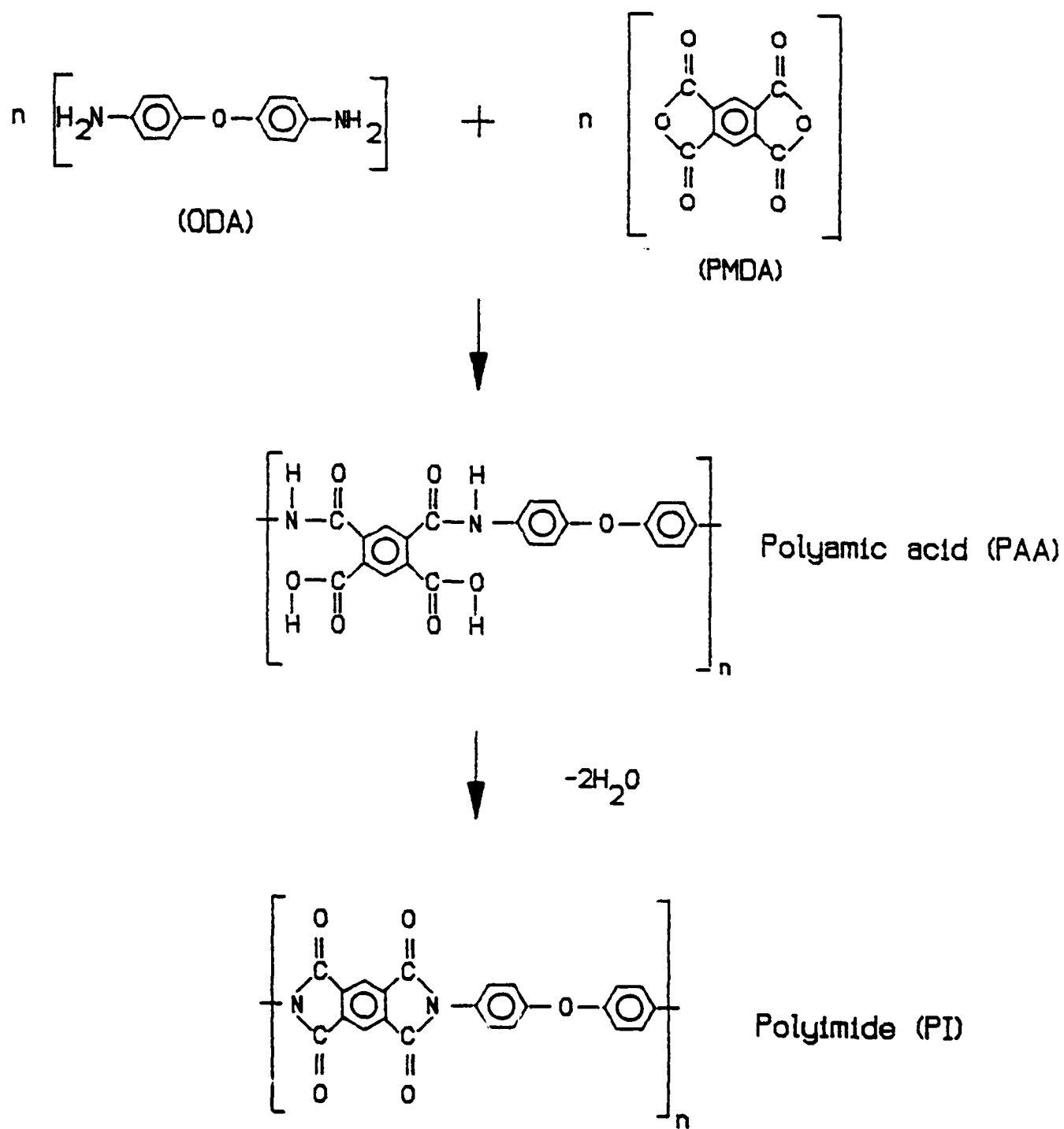

Fig 1. Reaction mechanism for ODA-PMDA polyimide film formation

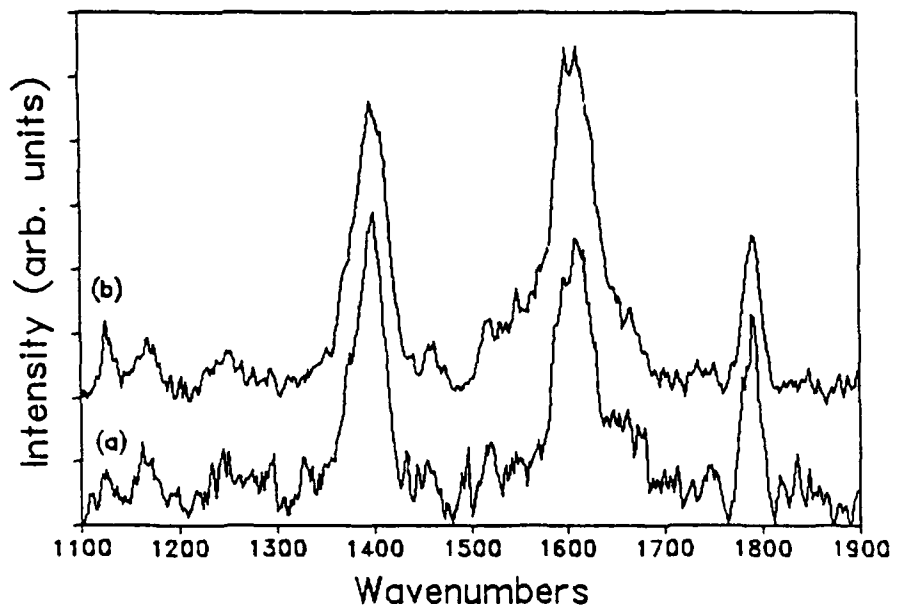

Fig 2. Raman spectra of (a) 1:1 vapor deposited polyimide and (b) 15:1 excess ODA dose films cured at 473 K for 30 min

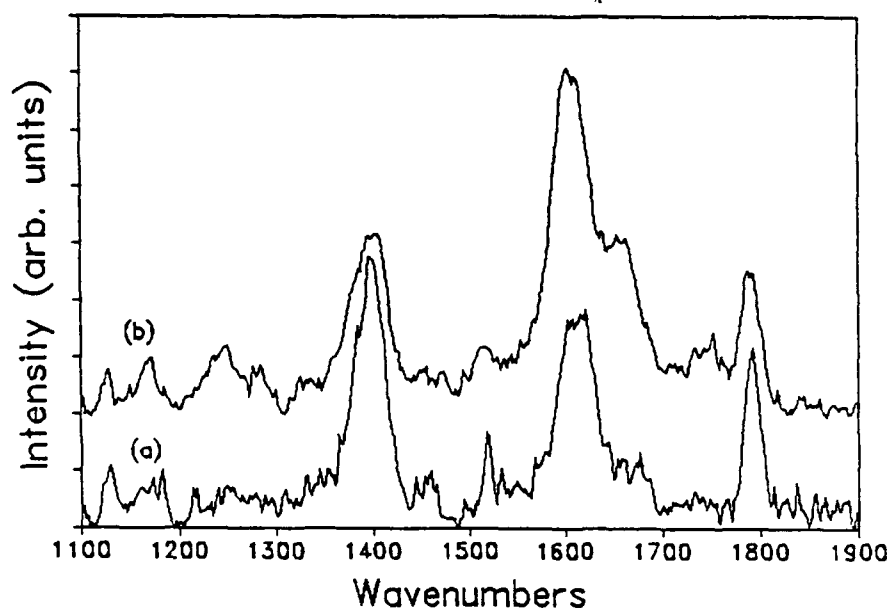

Fig 3. Raman spectra of (a) 1:1 vapor deposited and (b) 15:1 excess ODA films after curing at 573 K for 30 min

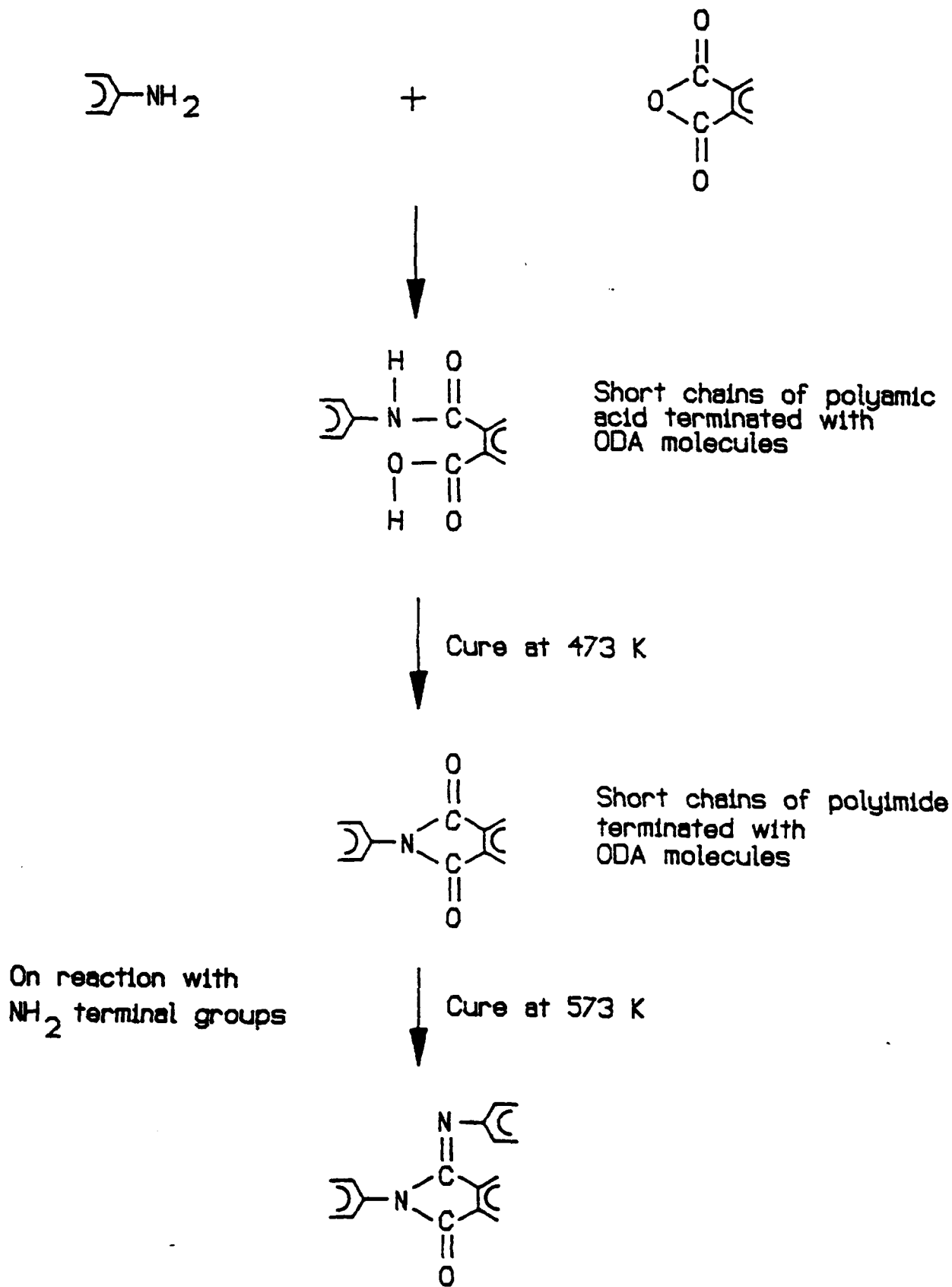

Fig 4. Reaction mechanism for the formation of imine interlinks

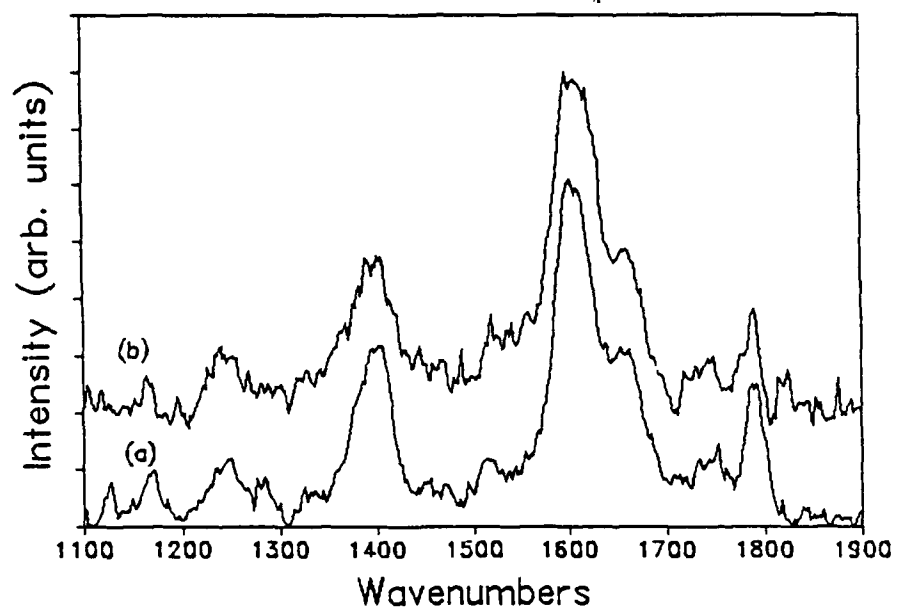

Fig 5. Raman spectra of the 15:1 excess ODA dose sample cured at 573 K for (a) 30 min and (b) 2 hours

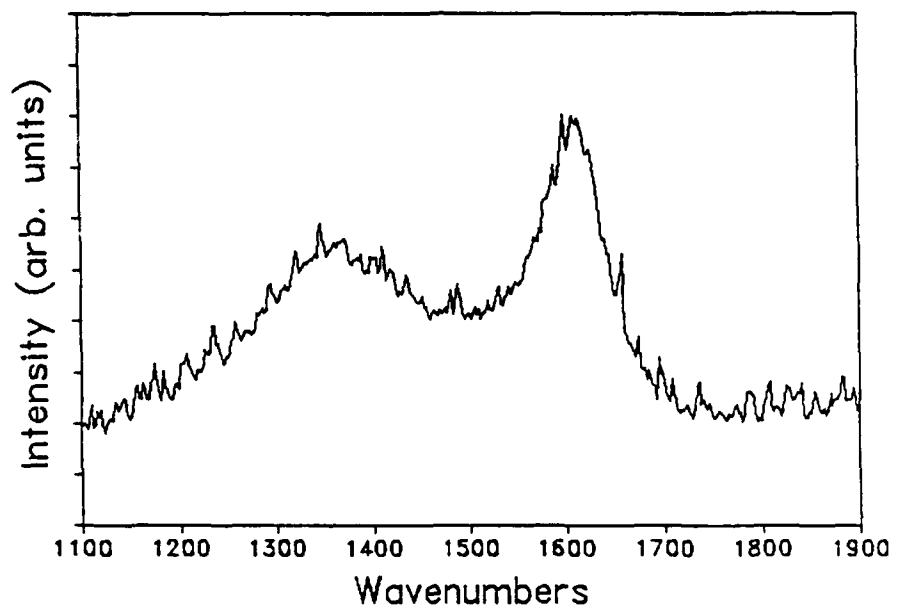

Fig 6. Raman spectra of the 15:1 excess ODA film after curing at 623 K for 30 min

TECHNICAL REPORT DISTRIBUTION LIST - GENERAL

Office of Naval Research (2)
Chemistry Division, Code 1113
800 North Quincy Street
Arlington, Virginia 22217-5000

Commanding Officer (1)
Naval Weapons Support Center
Dr. Bernard E. Douda
Crane, Indiana 47522-5050

Dr. Richard W. Drisko (1)
Naval Civil Engineering
Laboratory
Code L52
Port Hueneme, CA 93043

David Taylor Research Center (1)
Dr. Eugene C. Fischer
Annapolis, MD 21402-5067

Dr. James S. Murday (1)
Chemistry Division, Code 6100
Naval Research Laboratory
Washington, D.C. 20375-5000

Defense Technical Information Center (2)
Building 5, Cameron Station (high quality)
Alexandria, VA 22314

Dr. Robert Green, Director (1)
Chemistry Division, Code 385
Naval Weapons Center
China Lake, CA 93555-6001

Chief of Naval Research (1)
Special Assistant for Marine
Corps Matters
Code 00MC
800 North Quincy Street
Arlington, VA 22217-5000

Dr. Bernadette Eichinger (1)
Naval Ship Systems Engineering
Station
Code 053
Philadelphia Naval Base
Philadelphia, PA 19112

Dr. Sachio Yamamoto (1)
Naval Ocean Systems Center
Code 52
San Diego, CA 92152-5000

Dr. Harold H. Singerman (1)
David Taylor Research Center
Code 283
Annapolis, MD 21402-5067