

AD-A239 099



N89-88015

1

NASA
Technical Memorandum 102134

AVSCOM
Technical Report 89-C-004

Topology of Modified Helical Gears

F.L. Litvin and J. Zhang
*University of Illinois at Chicago
Chicago, Illinois*

R.F. Handschuh
*Propulsion Directorate
U.S. Army Aviation Research and Technology Activity—AVSCOM
Lewis Research Center
Cleveland, Ohio*

and

J.J. Coy
*Lewis Research Center
Cleveland, Ohio*

Prepared for the
5th International Power Transmission and Gearing Conference
sponsored by the American Society of Mechanical Engineers
Chicago, Illinois, April 24-27, 1989

NASA

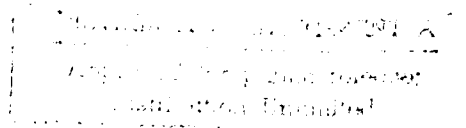

US ARMY
AVIATION
SYSTEMS COMMAND
AVIATION R&T ACTIVITY

86 91-06769



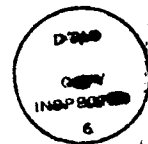

DTIC (GRA&I)	<input type="checkbox"/>
DTIC TAB	<input type="checkbox"/>
UNCLASSIFIED	<input type="checkbox"/>
Justification	
By	
Classification	
Availability Codes	
Avail and/or	
Special	

TOPOLOGY OF MODIFIED HELICAL GEARS

F.L. Litvin and J. Zhang
 University of Illinois at Chicago
 Department of Mechanical Engineering
 Chicago, Illinois 60680

R.F. Handschuh
 Propulsion Directorate
 U.S. Army Aviation Research and Technology Activity - AVSCOM
 Lewis Research Center
 Cleveland, Ohio 44135

and

J.J. Coy
 National Aeronautics and Space Administration
 Lewis Research Center
 Cleveland, Ohio 44135

SUMMARY

The topology of several types of modified surfaces of helical gears are proposed. The modified surfaces allow absorption of linear or almost linear function of transmission errors caused by gear misalignment, and improvement of the contact of gear tooth surfaces. Principles and corresponding programs for computer aided simulation of meshing and contact of gears have been developed. The results of this investigation are illustrated with numerical examples.

1. INTRODUCTION

Traditional methods for generation of involute helical gears with parallel axes provide developed ruled tooth surfaces for the gear teeth (fig. 1). The tooth surfaces contact each other at every instant along a line, L, that is the tangent to the helix on the base cylinder. The surface normals along L do not change their orientation. The disadvantage of regular helical gears is that they are very sensitive to misalignments such as the crossing or intersection of gear axes. The misaligned gears transform rotation with a linear function or transmission errors and the bearing contact is shifted to the edge of teeth. The frequency of transmission errors coincides with the frequency of the change of teeth being in mesh. The actual contact ratio (the average number of teeth being in mesh at every instant) is close to one and is far from the expected value.

These are the reasons why we have to reconsider the canonical ideas on involute helical gears and modify their tooth surfaces. Crowning the gear surface is needed to negate the effects of transmission errors and the shift of contact between the gear tooth surfaces. Deviations of screw involute gear tooth surfaces to provide a new topology that can reduce the gear sensitivity to misalignment will be developed. Theoretically the modified tooth surfaces will be in contact at every instant at a point instead of a line. Actually, due to the transmitted load the contact will be spread over an elliptical area

E-4054

whose dimensions may be controlled. Methods for gear tooth surface generation that provide the desirable surface deviation are proposed. For economical reasons only the pinion tooth surface is modified while the gear tooth surface is kept as a regular screw involute surface.

2. SIMULATION OF MESHING

The investigation of influence of gear misalignment requires a numerical solution for the simulation of meshing and contact of gear tooth surfaces. The basic ideas of this method (ref. 2) are as follows:

(1) The meshing of gear tooth surfaces is considered in a fixed coordinate system, S_f . Usually, the generated gear tooth surfaces may be represented in a three parametric form with an additional relation between these parameters - Gaussian coordinates. Such a form is the result of representation of the gear tooth surface as an envelope of the family of the tool surface (the generating surface) and two of the three Gaussian coordinates are inherited from the tool surface.

The continuous tangency of gear tooth surfaces is represented by the following equations

$$\tilde{r}^{(1)}(u_1, \theta_1, \psi_1, \phi_1) = \tilde{r}^{(2)}(u_2, \theta_2, \psi_2, \phi_2) \quad (2.1)$$

$$\tilde{n}^{(1)}(u_1, \theta_1, \psi_1, \phi_2) = \tilde{n}^{(2)}(u_2, \theta_2, \psi_2, \phi_2), \quad |\tilde{n}^{(1)}| = |\tilde{n}^{(2)}| \quad (2.2)$$

$$f_6(u_1, \theta_1, \psi_1) = 0 \quad (2.3)$$

$$f_7(u_2, \theta_2, \psi_2) = 0 \quad (2.4)$$

Here: u_i and θ_i are the tool surface curvilinear coordinates, ψ_i is the parameter of motion in the process of generation of the gear tooth surface, θ_i is the angle of rotation of the gear being in mesh with the mating gear.

Equations (2.1) to (2.4) provide that the position vectors $\tilde{r}^{(1)}$ and $\tilde{r}^{(2)}$ and surface unit normals $\tilde{n}^{(1)}$ and $\tilde{n}^{(2)}$ are equal for the gear tooth surfaces in contact (fig. 2). Vector equations (2.1) and (2.2) yield five independent equations and the total equation system is

$$f_i(u_1, \theta_1, \phi_1, u_2, \theta_2, \phi_2, \psi_1, \psi_2) = 0, \quad i \in [1, 5], \quad (2.5)$$

$$f_6(u_1, \theta_1, \psi_1) = 0, \quad f_7(u_2, \theta_2, \psi_2) = 0$$

An instantaneous point contact instead of a line contact is guaranteed if the Jacobian differs from zero, i.e. if

$$\frac{D(f_1, f_2, f_3, f_4, f_5, f_6, f_7)}{D(u_1, \theta_1, \psi_1, u_2, \theta_2, \psi_2, \phi_2)} \neq 0 \quad (2.6)$$

if the inequality equation (2.6) is observed, then the system of equation (2.5) may be solved in the neighborhood of the contact point by functions

$$u_1(\phi_1), u_2(\phi_1), \psi_1(\phi_1), \dots, \phi_2(\phi_1) \quad (2.7)$$

These functions of class C^1 (at least they have continuous derivatives of the first order). Functions (2.7) and equations (2.5) provide the information on the transmission errors (deviation of $\phi_2(\phi_1)$ from the prescribed linear function) and the path of the contact point over the gear tooth surface.

For the case when the gear tooth surface is a regular screw involute surface, it may be directly represented in a two-parametric form and the number of equations in system (2.5) may be reduced to six.

3. SIMULATION OF CONTACT

Due to the elastic approach of the gear tooth surfaces their contact is spread over an elliptical area. It is assumed that the magnitude of the elastic approach is known from experiments or may be predicted. Knowing in addition the principle curvatures and directions for two contacting surfaces at their point of contact we may determine the dimensions and orientation of the contact ellipse (ref. 2).

The determination of principal curvatures and directions for a surface represented in a three-parametric form is a complicated computational problem. A substantial simplification of this problem may be achieved using the relations between principle curvatures and directions, and the parameters of motion for two surfaces being in contact at a line. One of the contacting surfaces is the tool surface and the other is the generated surface.

Helical gears with modified gear tooth surfaces will be designed as surfaces being in point contact at every instant. The point of contact traces out on the surface a spatial curve (the path of contact) whose location must be controlled. The tangent to the path of contact and the derivative of the gear ratio $d(m_{21}(\phi_1))/d\phi_2$ may be controlled by using the relationship between principle curvatures and directions for the two surfaces that are in point contact (ref. 2). Here:

$$m_{21} = \frac{\omega^{(2)}}{\omega^{(1)}} = f(\phi_1)$$

is the gear ratio.

4. PARTIAL COMPENSATION OF TRANSMISSION ERRORS

Nonmisaligned gears transform rotation with a constant gear ratio m_{21} and

$$\phi_2^0(\phi_1) = \frac{N_1}{N_2} \phi_1$$

is a linear function. Here: N_1 and N_2 are the number of gear teeth. An investigation of the effect of helical gear rotational axis intersection or crossing indicates that $\phi_2(\phi_1)$ becomes a piece-wise function which is nearly linear for each cycle of meshing (fig.3(a)). The transmission errors are determined by

$$\Delta\phi_2(\phi_1) = \phi_2(\phi_1) - \phi_1 \frac{N_1}{N_2} \quad (4.1)$$

and they are also represented by a piece-wise linear function (fig. 3(b)). Transmission errors of this type cause a discontinuity of the gear angular velocity at transfer points and vibration becomes inevitable. The new topology of gear tooth surfaces proposed in this article allows the absorption of a linear function of transmission errors that results in a reduced level of vibration. This is based on the possibility to absorb a linear function by a parabolic function.

Consider the interaction of a parabolic function given by

$$\Delta\phi_2^{(1)} = -a\phi_1^2 \quad (4.2)$$

with a linear function represented by

$$\Delta\phi_2^{(2)} = b\phi_1 \quad (4.3)$$

The resulting function

$$\Delta\phi_2 = b\phi_1 - a\phi_1^2 \quad (4.4)$$

may be represented in a new coordinate system by (fig. 4):

$$\psi_2 = -a\psi_1^2 \quad (4.5)$$

where

$$\psi_2 = \Delta\phi_2 - \frac{b^2}{4a}, \quad \psi_1 = \phi_1 - \frac{b}{2a} \quad (4.6)$$

We consider that $\Delta\phi_2^{(1)} = -a\phi_1^2$ is a predesigned function that exists even if misalignments do not appear. The absorption of function $\Delta\phi_2^{(2)} = b\phi_1$ by the parabolic function $\Delta\phi_2^{(1)} = -a\phi_1^2$ means that gear misalignment does not change

the predesigned parabolic function of transmission errors. Thus the resulting function of transmission errors $\Delta\phi_2 = \Delta\phi_2^{(1)} + \Delta\phi_2^{(2)}$ will keep its shape as a parabolic function although the gears are misaligned. The resulting function of transmission errors $\phi_2(\phi_1)$ may be obtained by translation of the parabola

The absorption of a linear function of transmission errors by a parabolic function is accompanied by the change of transfer points. The transfer points determine the positions of the gears where one pair of teeth is rotating out of mesh and the next pair is coming into mesh. The change of transfer points for the pinion is determined as $\left| \frac{b}{2a} \right|$ and for the gear $\frac{b^2}{4a}$. The cycle of meshing

of one pair of teeth is given by: $\phi_i = \frac{2\pi}{N_i}$ $i \in 1, 2$. It may happen that the absorption of a linear function by a parabolic function is accompanied with a change that is too large. If this occurs the transfer points and the resulting parabolic function of transmission errors, $\psi_2(\psi_1)$, will be represented as a discontinuous function for one cycle of meshing (fig. 5). To avoid this, it is necessary to limit the tolerances for gear misalignment.

5. MISALIGNMENT OF REGULAR HELICAL GEARS

The computer aided simulation of meshing of misaligned helical gears with regular tooth surfaces shows: (1) the bearing contact is shifted to the edge of the tooth, and (2) transformation of rotation is accompanied with large transmission errors. There are two sub-cycles of meshing during the complete meshing cycle for one pair of teeth. These sub-cycles correspond to the meshing of (1) a curve with a surface, and (2) a point with a surface. The curve is the involute curve at the edge of the tooth of the gear and the point is the tip of the gear tooth edge. The transmission errors for the period of a cycle are represented by two linear functions (fig. 6). The transformation of rotation will be accompanied with a jump of the angular velocity of the driven gear and therefore vibrations are inevitable.

The results of computation are presented for the following case:
 Given: the number of teeth are $N_1 = 20$, $N_2 = 40$ the helix angle is $\beta = 15^\circ$, the normal pressure angle is $\psi_n = 20^\circ$. The gear axes are crossed and form an angle $\Delta\gamma = 5$ arc minutes. The computed transmission errors are represented in table 5.1.

6. SURFACE DEVIATION BY THE CHANGE OF PINION LEAD

A method of reducing the sensitivity to misalignment for the case of crossed helical gears is surface deviation by the change of pinion lead. The crossing angle γ is chosen with respect to the expected tolerances of the gear misalignment (γ is the range of 10 to 15 arc minutes). The gear ratio for helical gears with crossed axes may be represented by (ref. 2):

$$M_{12} = \frac{\omega^{(1)}}{\omega^{(2)}} = \frac{r_{b2} \sin \lambda_{b2}}{r_{b1} \sin \lambda_{b1}} \quad (6.1)$$

where r_{bi} and λ_{bi} are the radius of the base cylinder and the lead angle on this cylinder, $i \in 1, 2$. $|\lambda_{p2} - \lambda_{p1}| = \gamma$. Here: λ_{pi} is the lead angle on the pitch cylinder. The advantage of this type of surface deviation for crossed helical gears is that the gear ratio is not changed by the misalignment (by the change of γ). The disadvantage of this type of surface deviation is that location of the bearing contact of the gears is very sensitive to gear misalignment. A slight change of the crossing angle causes shifting of the contact to the edge of the tooth (fig. 7).

The discussed type of surface deviation is reasonable to apply for manufacturing of expensive reducers of large dimensions when the lead of the pinion can be adjusted by regrinding. Parameters r_{b1} and λ_{b1} are changed for regrinding. However, the parameters must be adjusted so that the product of $r_{b1} \sin \lambda_{b1}$ is not changed by regrinding. Then, the gear ratio M_{21} will be of the prescribed value and transmission errors caused by the crossing of the axes will be zero.

Theoretically, transmission errors are inevitable if the axes of crossed helical gears become intersected. Actually, if gear misalignment is of the range of 5 to 10 arc minutes, the transmission errors are very small and may be neglected. The main problem for this type of misalignment is again the shift of the bearing contact to the edge (fig. 7).

7. GENERATION OF PINION TOOTH SURFACE BY A SURFACE OF REVOLUTION

The purpose of this method for deviation of the pinion tooth surface is: (1) to reduce the sensitivity of the gears to misalignment; (2) keep transmission error to a low level; and (3) stabilize the bearing contact. This investigation shows that these goals may be achieved by the proposed method of crowning. However, with this method the instantaneous contact ellipse moves across but not along the surface (fig. 8). Therefore the bearing contact cannot cover the whole surface.

The proposed method for generation is based on the following consideration. It is well known that the generation of a helical gear may be performed by an imaginary rack-cutter with skew teeth whose normal section represents a regular rack-cutter for spur gears (fig. 9(a)). We may imagine that two generating surfaces, Σ_g and Σ_p , are applied to generate the gear tooth surface and the pinion tooth surface, respectively (fig. 9(b)). Surface Σ_g is a plane (a regular rack-cutter surface), and Σ_p is a cone surface. Surfaces Σ_g and Σ_p are rigidly connected and perform translational motion, while the pinion and the gear rotate about their axes (fig. 10). The generated pinion and gear will be in point contact and transform rotation with the prescribed linear function $\phi_2(\phi_1)$. However, due to gear misalignment, function $\phi_2(\phi_1)$ becomes a piecewise function (fig. 3(a)) that is not acceptable. To absorb a linear function of transmission errors (3(b)), a predesigned parabolic function of transmission errors is used. For this reason a surface of revolution that slightly deviates from the cone surface is proposed (fig. 9(c)). The radius of the surface of revolution in its axial section determines the level of the predesigned parabolic function.

The meshing of gears using the crowning method described in this section has been simulated by numerical methods. The results of the investigation are illustrated with the following example.

Given: number of pinion teeth $N_1 = 20$, number of gear teeth $N_2 = 40$, diametral pitch in normal section $P_n = 10 \text{ in}^{-1}$, pressure angle in normal section $\psi_n = 20^\circ$, helix angle $\beta = 15^\circ$. The pinion tooth is crowned by involute surface with generatrix arc $\rho = 30 \text{ in}$. The involute surface is deviated from a cone (comparing Σ_p in figs. 9(b) and (c)). The cone has half apex angle $\alpha = 20^\circ$ and bottom radius $R = 10.6 \text{ in}$.

The topology of the pinion tooth surface provides a parabolic type of pre-designed transmission errors with $d = 6$ arc seconds (fig. 4(a)) and a path contact that is directed across the tooth surface (fig. 8).

The influence of gear misalignment has been investigated with the developed computer program and the results of computation are represented in table 7.1 and 7.2 for crossed and intersected gear axes, respectively. The misalignment of gear axes is 5 arc minutes.

The results of computation show that the resulting function of transmission errors is a parabolic one. Thus the linear function of transmission errors that was caused by gear misalignment has been absorbed by the pre-designed parabolic function.

8. CROWNED HELICAL PINION WITH LONGITUDINAL PATH CONTACT

A longitudinal path of contact means that the gear tooth surfaces are in contact at a point at every instant and the instantaneous contact ellipse moves along but not across the surface (fig. 11(a)). It can be expected that this type of contact provides improved conditions of lubrication. Until now only the Novikov-Wildhaber's gears could provide a longitudinal path of contact. A disadvantage of Novikov-Wildhaber gearing is their sensitivity to the change of the center distance and axes misalignment. The sensitivity to non-ideal orientation of the meshing gears cause a higher level of gear noise in comparison with regular involute helical gears. Litvin et al. (ref. 3) proposed a compromising type of nonconformal helical gears that may be placed between regular helical gears and Novikov-Wildhaber helical gears. The gears of the proposed gear train are the combination of regular involute helical gear and a specially crowned helical pinion. The investigation of transmission errors for helical gears with a longitudinal path of contact shows that their good bearing contact is accompanied with an undesirable increased level of linear transmission errors. The authors propose to compensate this disadvantage by a pre-designed parabolic function of transmission errors that will absorb the linear function of transmission errors (see section 4). The two following methods for derivation of the pinion tooth surface with the modified topology will now be considered.

Method 1

Consider that two rigidly connected generating surfaces, Σ_g and Σ_p , are used for the generation of the gear and the pinion, respectively (fig. 11(b)). Surface Σ_g is a plane and represents the surface of a regular rack-

cutter; surface Σ_p is a cylindrical surface whose cross-section is a circular arc. We may imagine that while surfaces Σ_g and Σ_p translate, as the pinion and the gear rotate about their axes. To provide the pre-designed parabolic function of transmission errors it is necessary to observe the following transmission functions by generation

$$\frac{V}{\omega^{(2)}} = r_2 = \text{const}, \quad \frac{V}{\omega^{(1)}} = r_2 \left(\frac{N_1}{N_2} - 2a\phi_1 \right) = f(\phi_1) \quad (8.1)$$

Here: $\omega^{(1)}$ and $\omega^{(2)}$ are the angular velocities of pinion and gear during cutting; V is the velocity of the rack-cutter in translational motion; N_1 and N_2 are the gear and pinion tooth numbers; ϕ_1 is the angle of rotation of the pinion during cutting. The generated gears will be in point contact at every instant and transform rotation with the function

$$\phi_2(\phi_1) = \frac{N_1}{N_2} \phi_1 - a\phi_1^2 \quad 0 \leq \phi_1 \leq \frac{2\pi}{N_1} \quad (8.2)$$

This function relates the angles of rotation of the pinion and the gear, ϕ_1 and ϕ_2 , respectively, for one cycle of meshing. The pre-designed function of transmission errors is

$$\Delta\phi_2 = -a\phi_1^2 \quad (8.3)$$

It is evident that after differentiation of function (8.2) we obtain that the gear ratio $\omega^{(2)}/\omega^{(1)}$ satisfies equation (8.1).

To apply this method of generation in practice it is necessary to vary the angular velocity of the pinion in the process of its generation. This may be accomplished by a computer controlled machine for cutting.

Method 2

The derivation of the crowned pinion tooth surface is based on two stages of synthesis. On the first stage it is assumed that only one generating surface, plane Σ_g , is used to generate both mating surfaces - gear tooth surface, Σ_2 , and the pinion tooth surface, Σ_1 . To provide the pre-designed parabolic function of transmission errors, the velocity V in translational motion of Σ_g and the angular velocities $\omega^{(2)}$ and $\omega^{(1)}$ of Σ_2 and Σ_1 are related by equation (8.1). Then, the generated gear tooth surfaces, Σ_1 and Σ_2 , will be in line contact at every instant and transform rotation with the piecewise function (8.2).

On the second stage of synthesis it is necessary to localize the bearing contact and substitute the instantaneous line contact by the point contact. This becomes possible if the pinion tooth surface will deviate as it is shown in figure 11(c). Only a narrow strip, L , will be kept while Σ_1 will be changed into Σ_1' . The deviation of Σ_1' with respect to Σ_1 may be accomplished in various ways, for instance; in such a way, that the cross-section of Σ_1' is just a

circular arc. The generation of Σ_1' requires a computer controlled machine to relate the motions of the tool surface and being generated pinion surface Σ_1 . The tool surface (it may be just a plane) and Σ_1 will be the point contact in the process of generation (ref. 4).

Comparing the two methods for the generation of the pinion tooth surface, it may be concluded that both provide a localized bearing contact, a longitudinal path of contact and predesigned parabolic function of transmission error. The difference between these methods is that the tool and pinion tooth surfaces are in line contact by applying the first method for generation and in point contact by the second one. The disadvantage of both methods for crowning of the pinion is that the transmission errors caused by gear misalignment are large and it is necessary to foresee a high level of the predesigned parabolic function for the absorption of transmission errors. This is illustrated with the following example.

Given (the data is from ref. 3); pinion tooth number $N_1 = 12$, gear tooth number $N_2 = 94$; diametral pitch in normal section $P_n = 2 \text{ in}^{-1}$; pressure angle in normal section $\psi_n = 30^\circ$; helix angle $\beta = 15^\circ$.

The pinion tooth surface is a crowned surface whose cross-section is an arc of a circle of the radius 0.3584. The predesigned parabolic function is of the level $d = 25$ arc seconds (fig. 4(a)).

Consider now that the axes of the gear and the pinion are crossed and the crossing angle is 3 arc minutes. The computer program for the simulation of meshing provides the data of transmission errors that is given in table 8.1. The data of table 8.1 shows that the resulting function of transmission errors is a parabolic function. Thus, the linear function of transmission errors caused by misalignment of gear axes has been absorbed by the predesigned parabolic function.

Table 8.2 represents the transmission errors for the same helical gears for the case when the gear axes are intersected and form an angle of 3 arc minutes. The resulting function of transmission errors is again a parabolic function with the level $d = 26.2$ arc seconds. The relatively high level of transmission errors is the price that must be paid for the longitudinal path of contact. However, the proposed topology of the pinion tooth surface provides a reduction of the level of gear noise since the linear function of transmission errors is substituted by a parabolic function.

8. CONCLUSION

A new topology has been developed for several types of helical gears. Principles of computer aided simulation of meshing, contact, and respective computer programs have also been developed. These ideas have been applied for helical gears with modified gear tooth surfaces that allow a reduction of transmission errors and improve the bearing contact. The results of numerical examples of crowned helical gears show that their synthesis should be based on a compromise between the requirements of transmission errors and the patterns of the bearing contact.

REFERENCES

1. Chironis, N.P., 1967 "Design of Novikov Gear," Gear Design and Application, N.P. Chironis, ed., McGraw-Hill, New York.
2. Litvin, F.L., 1968, Theory of Gearing, 2nd edition, Moscow (in Russian), (NASA RP-1212, 1989, to be published).
3. Litvin, F.L. and Tsay, C.B., 1985, "Helical Gears with Circular Arc Teeth: Simulation of Conditions of Meshing and Bearing Contact," Mech. Transmissions, Automation Des. vol. 107, No. 4, pp. 556-564.
4. Litvin, F.L. and Zhang, J., et al., 1987, "Crowned Spur Gears: Optimal Geometry and Generation," AGMA Paper 87FTM7.
5. Maag Information 18, Topological Modification, Zurich.
6. Wildhaber, E., 1962, "Method and Machine for Producing Crowned Teeth," U.S.A. Patent 3,046,844.

TABLE 5.1 - TRANSMISSION ERRORS OF REGULAR HELICAL
GEARS WITH CROSSED AXES

ϕ_1 , deg	-8	-5	-2	1	4	7	10
$\Delta\phi_2$, arc-sec	4.90	3.06	1.22	-0.61	-2.45	-4.29	-6.12

TABLE 7.1 TRANSMISSION ERRORS OF CROSSED HELICAL GEARS

ϕ_1 , deg	-14	-11	-8	-5	-2	1	4
$\Delta\phi_2$, arc sec	-4.99	-1.51	0.65	-.51	1.05	-0.75	-3.87

TABLE 7.2 - TRANSMISSION ERRORS OF INTERSECTED HELICAL GEARS

ϕ_1 , deg	-11	-8	-5	-2	1	4	7
$\Delta\phi_2$, arc sec	-6.15	-2.72	-0.60	0.20	-0.32	-2.19	-5.40

TABLE 8.1 TRANSMISSION ERRORS FOR CROSSED HELICAL GEARS

ϕ_1 , deg	-23	-18	-13	-8	-3	2	7
$\Delta\phi_2$, arc sec	-17.94	-3.06	5.64	8.23	4.84	-4.39	-19.37

TABLE 8.2 - TRANSMISSION ERRORS OF INTERSECTED HELICAL GEARS

ϕ_1 , deg	-20	-15	-10	-5	0	5	10
$\Delta\phi_2$, arc sec	-23.06	-8.50	0.15	2.96	0.00	-8.66	-22.95

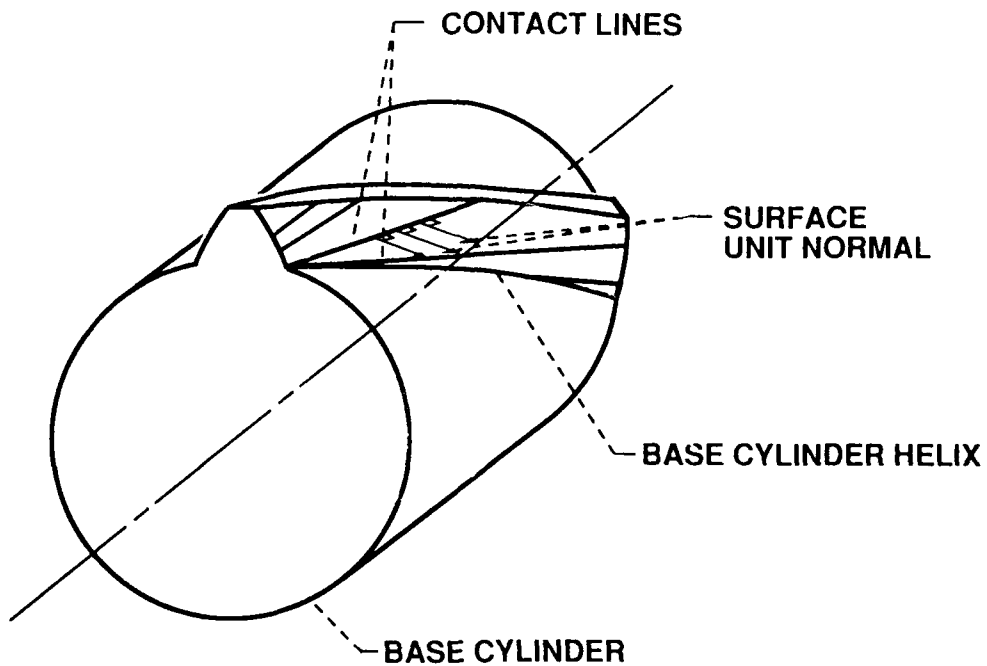

FIGURE 1. - SCREW INVOLUTE HELICAL GEAR.

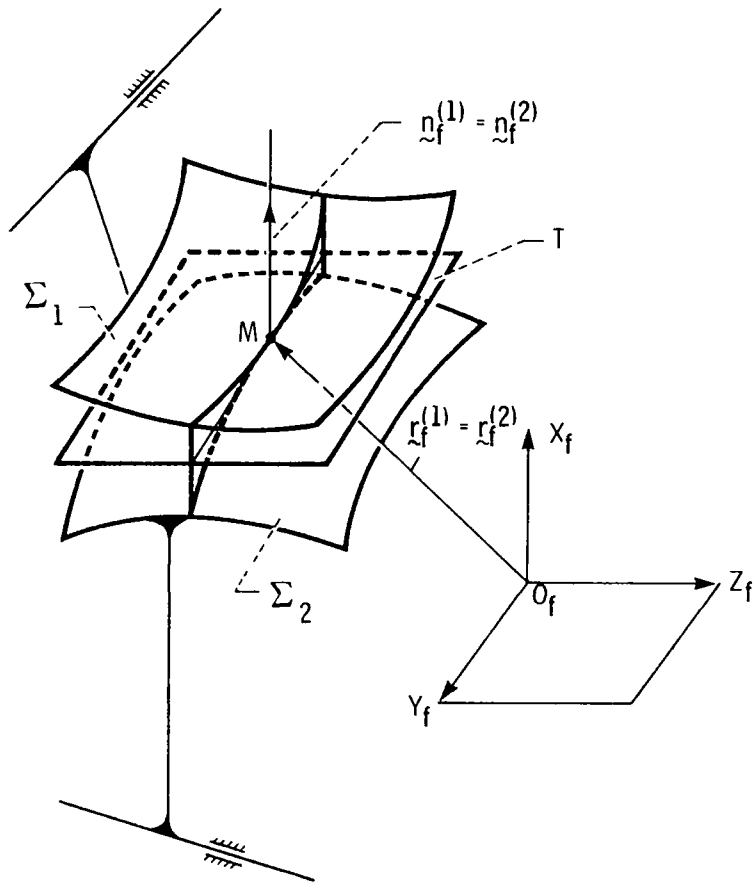
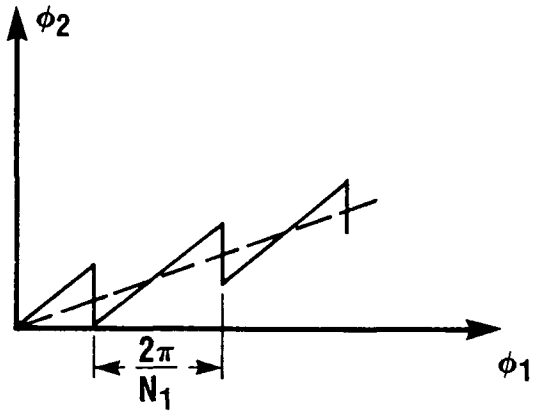
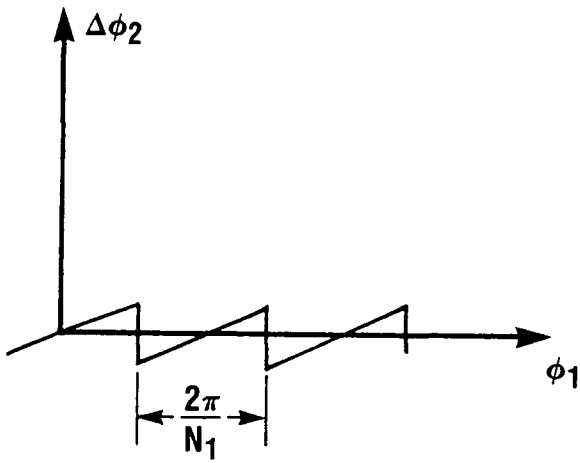

FIGURE 2. - CONTACTING TOOTH SURFACES.



(a)



(b)

FIGURE 3. - TRANSMISSION ERROR CAUSED BY GEAR MISALIGNMENT.

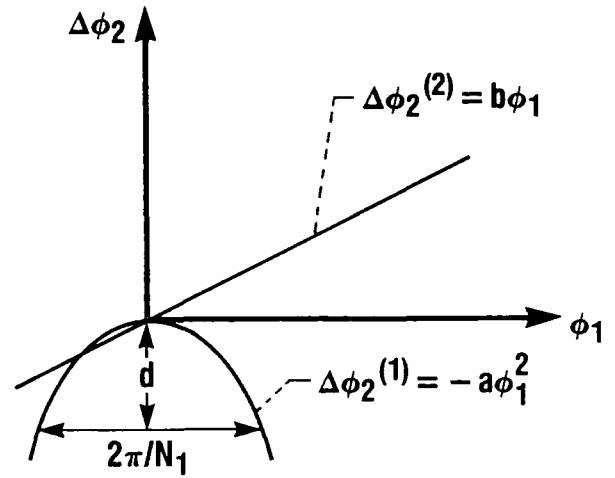

(a)

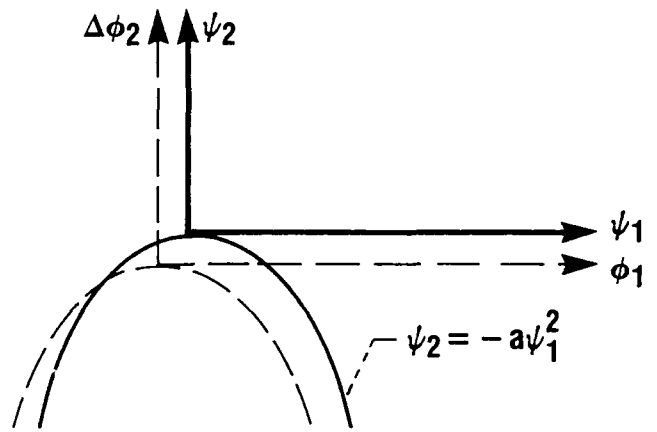

(b)

FIGURE 4. - INTERACTION OF PARABOLIC AND LINEAR FUNCTION.

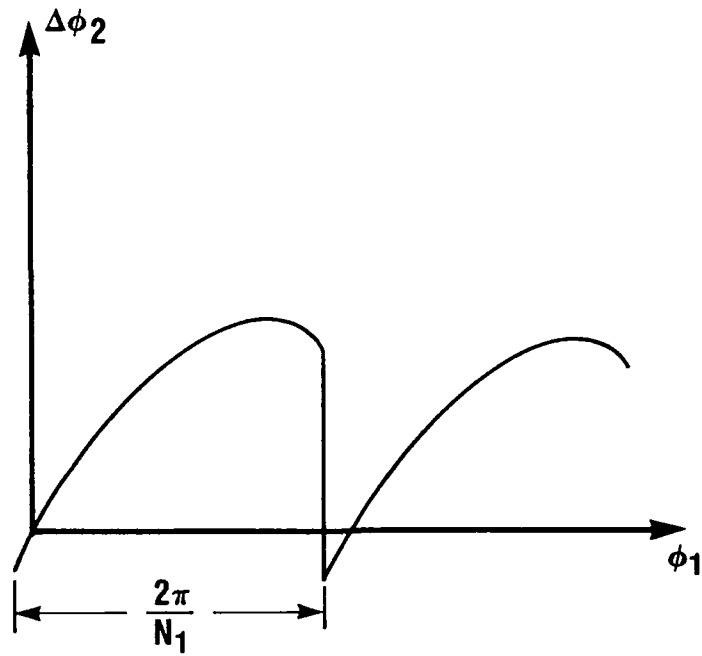

FIGURE 5. - DISCONTINUED PARABOLIC FUNCTION OF TRANSMISSION ERRORS.

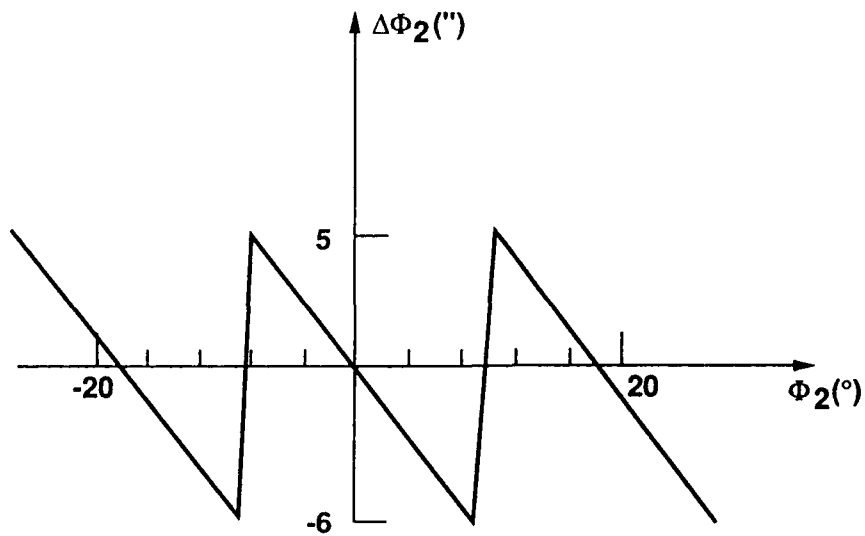

FIGURE 6. - TRANSMISSION ERROR OF HELICAL GEARS.

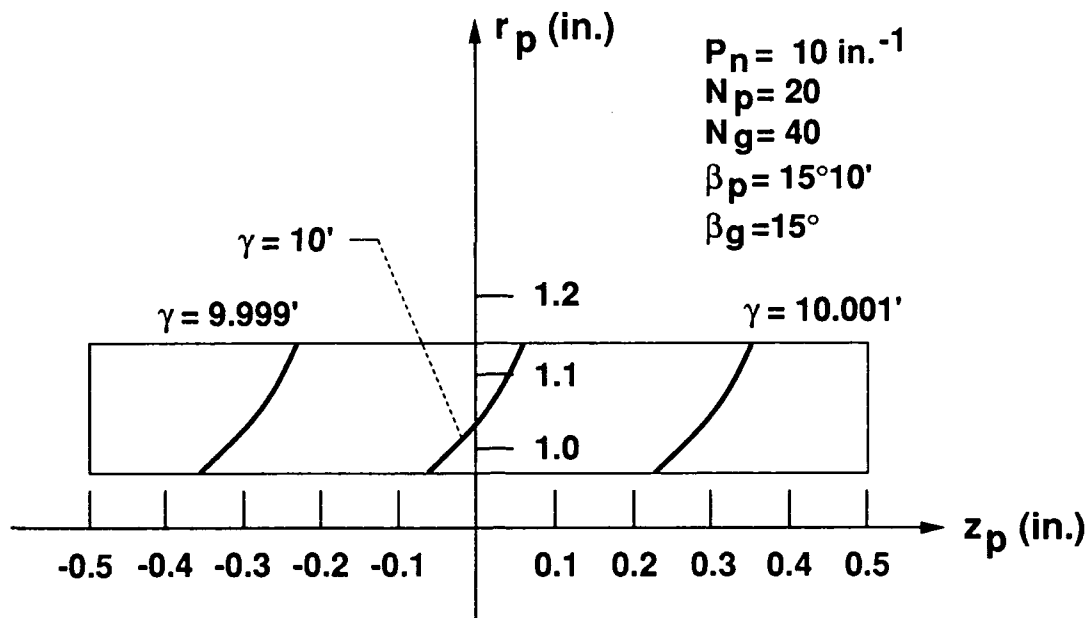

FIGURE 7. - SHIFT OF PATH OF CONTACT.

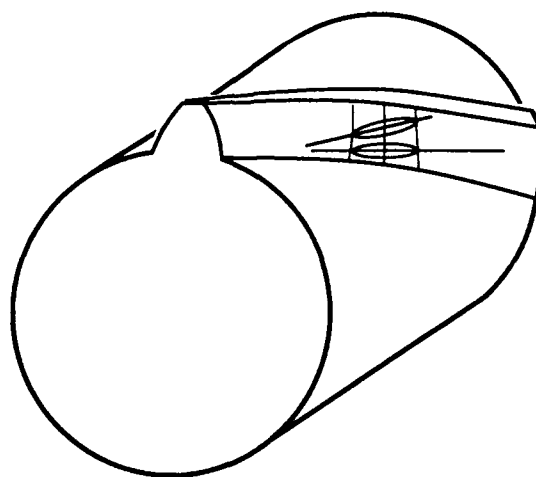
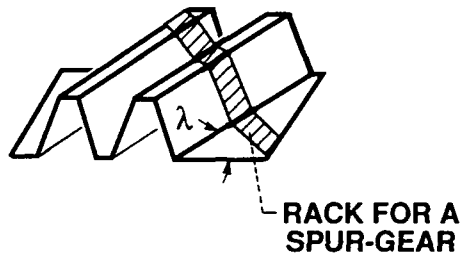
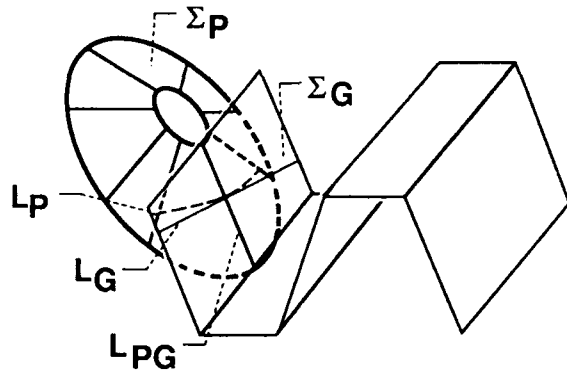

FIGURE 8. - CONTACT ELLIPSES ON THE PINION TOOTH SURFACE.



(a)



(b)

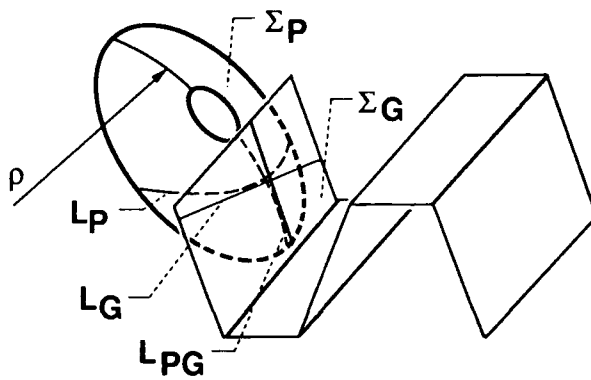

(c)

FIGURE 9. - GENERATION SURFACES.

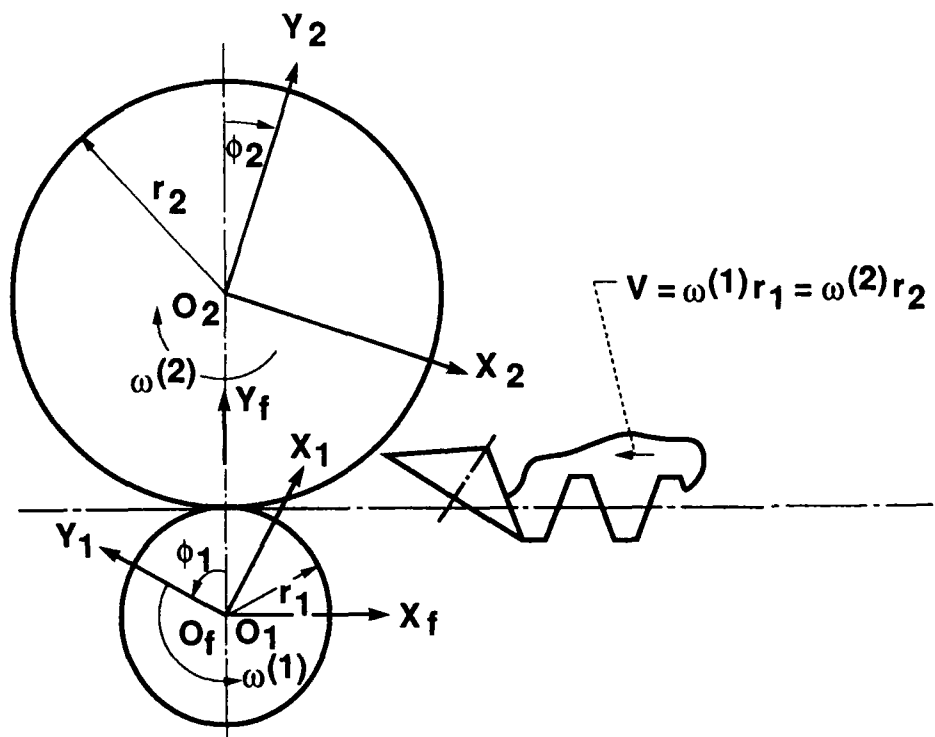

FIGURE 10. - GENERATION OF GEARS.

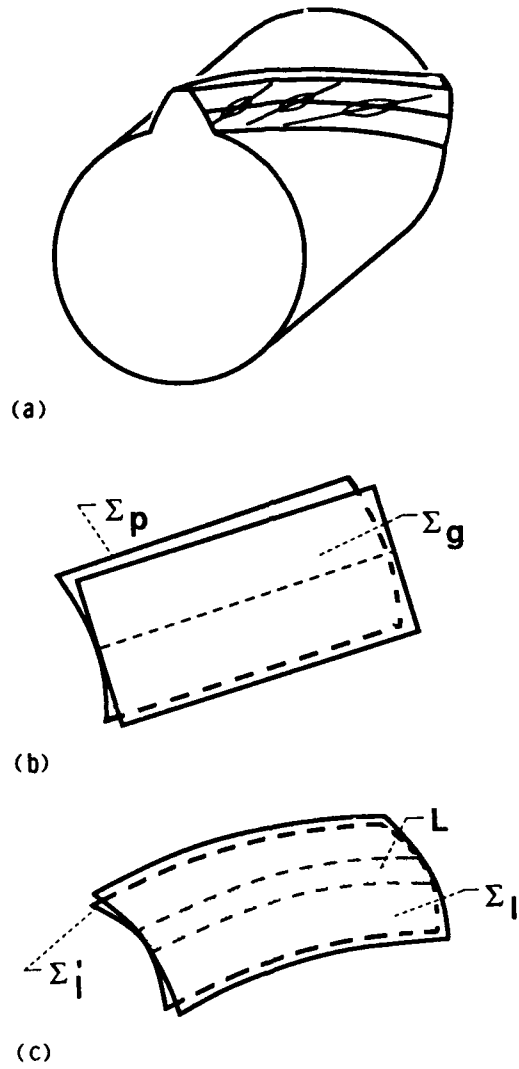

FIGURE 11. - HELICAL GEAR AND GENERATING TOOL SURFACE.

1. Report No. NASA TM-102134 AVSCOM TR 89-C-004		2. Government Accession No.		3. Recipient's Catalog No.	
4. Title and Subtitle Topology of Modified Helical Gears				5. Report Date	
				6. Performing Organization Code	
7. Author(s) F.L. Litvin, J. Zhang, R.F. Handschuh, and J.J. Coy				8. Performing Organization Report No. E-4054	
9. Performing Organization Name and Address NASA Lewis Research Center Cleveland, Ohio 44135-3191 and Propulsion Directorate U.S. Army Aviation Research and Technology Activity—AVSCOM Cleveland, Ohio 44135-3127				10. Work Unit No. 505-63-51 1L162209A47A ✓	
				11. Contract or Grant No.	
12. Sponsoring Agency Name and Address National Aeronautics and Space Administration Washington, D.C. 20546-0001 and U.S. Army Aviation Systems Command St. Louis, Mo. 63120-1798				13. Type of Report and Period Covered Technical Memorandum	
				14. Sponsoring Agency Code	
15. Supplementary Notes Prepared for the 5th International Power Transmission and Gearing Conference sponsored by the American Society of Mechanical Engineers, Chicago, Illinois, April 24-27, 1989. F.L. Litvin and J. Zhang, University of Illinois at Chicago, Chicago, Illinois; R.F. Handschuh, Propulsion Directorate, U.S. Army Aviation Research and Technology Activity—AVSCOM; J.J. Coy, NASA Lewis Research Center.					
16. Abstract The topology of several types of modified surfaces of helical gears are proposed. The modified surfaces allow absorption of linear or almost linear function of transmission errors caused by gear misalignment, and improvement of the contact of gear tooth surfaces. Principles and corresponding programs for computer aided simulation of meshing and contact of gears have been developed. The results of this investigation are illustrated with numerical examples.					
17. Key Words (Suggested by Author(s)) Gear geometry; Transmissions; Helical gears; Machine design			18. Distribution Statement Unclassified—Unlimited Subject Category 37		
19. Security Classif. (of this report) Unclassified		20. Security Classif. (of this page) Unclassified		21. No of pages 20	22. Price* A03