

AD-A239 235

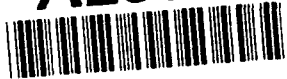

FTD-ID(RS)T-C169-91

2

FOREIGN TECHNOLOGY DIVISION



SOUTHERN AVIATION'S MICROWAVE DARK ROOM

by

Zhao Minggui

DTIC
SELECTE
AUGO 9 1991
S S D

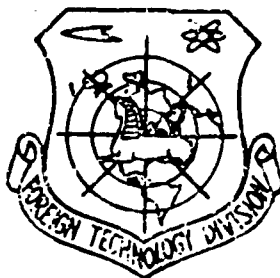

Approved for public release;
Distribution unlimited.

91-07248



91 8 27 085

HUMAN TRANSLATION

FTD-ID(RS)T-0169-91 5 June 1991

MICROFICHE NR: FTD-91-C-000416

SOUTHERN AVIATION'S MICROWAVE DARK ROOM

By: Zhao Minggui

English pages: 3

Source: Guoji Hangkong, Nr. 12, 1989,
pp. 52

Country of origin: China

Translated by: SCITRAN

F33657-84-D-0165

Requester: FTD/TTMM/Moorman

Approved for public release; Distribution unlimited.

THIS TRANSLATION IS A RENDITION OF THE ORIGINAL FOREIGN TEXT WITHOUT ANY ANALYTICAL OR EDITORIAL COMMENT STATEMENTS OR THEORIES ADVOCATED OR IMPLIED ARE THOSE OF THE SOURCE AND DO NOT NECESSARILY REFLECT THE POSITION OR OPINION OF THE FOREIGN TECHNOLOGY DIVISION

PREPARED BY

TRANSLATION DIVISION
FOREIGN TECHNOLOGY DIVISION
WPAFB OHIO

GRAPHICS DISCLAIMER

All figures, graphics, tables, equations, etc. merged into this translation were extracted from the best quality copy available.

Accession For	
NTIS GRA&I	<input checked="" type="checkbox"/>
DTIC TAB	<input type="checkbox"/>
Unannounced	<input type="checkbox"/>
Justification	
By	
Dist: <u>W/101</u>	
Availability Codes	
Avail and/or	
Dist	Special
A-1	

TITLE: SOUTHERN AVIATION'S MICROWAVE DARK ROOM

AUTHOR: Zhao Minggui

In order to experiment with electronics equipment interference, antenna properties, as well as to measure the radar reflection surface areas of aircraft, it was hoped to have a "free space" environment which has ideal electromagnetic shielding and satisfies distant field conditions. Normally, this type of environment should not be influenced by atmospheric factors. Moreover, it is capable of obtaining, from experimentation, precise data which is continuous and replicable. The first means for carrying out this type of simulation of "free space" is to opt for the use of a chamber which does not have echo waves--a microwave dark room.

A microwave dark room must have, inside a construction which satisfies definite distant field separation dimensions and definite spacial forms, high surface adhesion properties in wave absorbing materials, used in order to lower reflections from walls, floors, and ceilings, etc. This causes the electromagnetic waves from distant field locations to possess wave fronts which have the same amplitudes and the same phase. Satisfying the requirements described above causes the dark room, in areas of distant field experimentation, to form a "still area" or "dead zone" simulating "free space".

Southern Aviation, in early 1988, constructed a microwave dark room that was a rectangular chamber (See Fig.1). It was composed of an experimental chamber and a control room. The clean space was 27 meters x 8.5 meters x 8.5 meters. Inside it was affixed FA-800 and FA-400 wave absorbing materials. Along with this, in principal Fresnel regions, special handling was carried out. As a result of this, the electric level of reflection in the X wave band for the "dead zones" was caused to be lower than -53dB both when polarization was horizontal and when it was vertical.

As far as the microwave dark room is concerned, when antenna property experiments were carried out and radar reflection cross section surface area measurements were made, one normally opted for the use of scale models. The models were reduced in size by N times. The wavelengths had to be reduced N times, and then, the frequencies rose N times. Because of this, the upper limit of the operating frequency range for working with the microwave dark room was determined on the basis of the dimensions of the models, and the lower limits were determined by the properties of the wave absorbing materials. The Southern Aviation microwave dark room, has an operating frequency range, at the present time, of 1-18 GHz.

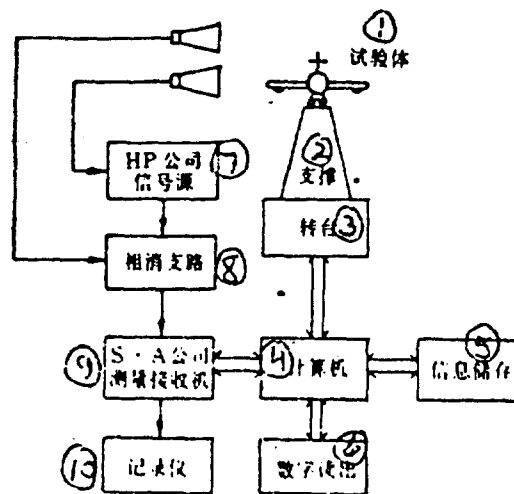

Fig.2 Microwave Dark Room Measurement System (1) Test Body (2) Support (3) Revolving Platform (4) Computer (5) Information Storage (6) Digital Readout (7) HP Company Signal Source (8) Phase Elimination Branch Circuit (9) S-A Company's Measurement Receiving Device (10) Recording Instrument

A schematic for the measurement system of the microwave dark room is as shown in Fig.2. As far as the HP Company's composite signal generator is concerned, it is a crystal vibration stabilized continuous wave signal source (its output power is +13dBm). After going through a wave tube power amplifier and being amplified, the output power is less than 1 Watt. As far as the microwave measurement receiving system manufactured by the S.A. Company is concerned, it includes a receiving device, an amplitude display device, and a directional antenna graphic recording instrument (orthogonal coordinates and polar coordinates). They are mutually connected with two wide frequency band loudspeaker feed sources. The target is placed on the revolving platform. It is capable of revolving 360° in 6 minutes. It is also capable of revolving 360° in 24 minutes. The data from the revolving platform and the received signals is picked up, processed, and controlled in operations carried out by the DEC Company's PDP-11/23 computer. In order to eliminate coupling between the antennas as well as other undesirable signal effects, in the schematic, there was added a background phase elimination branch circuit.

In order to stop outside electromagnetic interference and effects on measurement properties, the dark room opts for the use of a completely sealed type structure plated with a protective shielding of zinc and iron. This causes the electromagnetic wave interference from the outside world to be attenuated to 120 dB.

In the microwave dark room, one goes through optimization measurements from a pilotless airplane antenna array, antenna property measurements, radar reflection surface area measurements, as well as experimental research work on electromagnetic diffusion in the relevant wave guide models.

These dark room distant field conditions are not ideal ones in which one has level wave front surfaces with the same amplitudes and the same phase electromagnetic waves. There is a certain phase deviation or deflection. In order to raise the dark room properties as well as the precision of measurements, use will be made of the outstanding "field compression" system of the dark room apparatus.

DISTRIBUTION LIST

DISTRIBUTION DIRECT TO RECIPIENT

<u>ORGANIZATION</u>	<u>MICROFICHE</u>
B085 DIA/RIS-2FT	1
C509 BALL0C509 BALLISTIC RES LAB	1
C510 R&T LABS/AVEADCOM	1
C513 ARRADCOM	1
C535 AVRADCOM/TSARCOM	1
C539 TRASANA	1
Q592 FSTC	4
Q619 MSIC REDSTONE	1
Q008 NTIC	1
Q043 AFMIC-IS	1
E051 HQ USAF/INET	1
E404 AEDC/DOF	1
E408 AFWL	1
E410 ASDTC/IN	1
E411 ASD/FTD/TTIA	1
E429 SD/IND	1
P005 DOE/ISA/DOI	1
P050 CIA/OCR/ADD/SD	2
P085 NSA/...	1
1051 AFTT/LDE	1
CCV	1
P090 NSA/CDB	1
2206 FSL	1