

AD-A239 249

N 9 0 - 1 3 3 9 8

①



NASA  
Technical Memorandum 102422

AVSCOM  
Technical Report 89-C-013

# A Planar Reacting Shear Layer System for the Study of Fluid Dynamics- Combustion Interaction

C.J. Marek and C.T. Chang  
*National Aeronautics and Space Administration  
Lewis Research Center  
Cleveland, Ohio*

B. Ghorashi and C.C. Wey  
*Cleveland State University  
Cleveland, Ohio*

C. Wey  
*Sverdrup Technology, Inc.  
NASA Lewis Research Center Group  
Cleveland, Ohio*

E.J. Mularz  
*Space Propulsion Directorate  
U.S. Army Aviation Research and Technology Activity—AVSCOM  
Lewis Research Center  
Cleveland, Ohio*

Prepared for the  
23rd International Symposium on Combustion  
sponsored by The Combustion Institute  
University of Orléans, France, July 22-27, 1990

DTIC  
ELECTE  
AUG 0 8 1991  
S B D

DISTRIBUTION STATEMENT A

Approved for public release;  
Distribution Unlimited

91-07122



**NASA**



**A PLANAR REACTING SHEAR LAYER SYSTEM FOR THE STUDY OF FLUID  
DYNAMICS-COMBUSTION INTERACTIONS**

C.J. Marek and C.T. Chang  
National Aeronautics and Space Administration  
Lewis Research Center  
Cleveland, Ohio 44135

B. Ghorashi and C.C. Wey  
Cleveland State University  
Cleveland, Ohio 44115

C. Wey  
Sverdrup Technology, Inc.  
NASA Lewis Research Center Group  
Cleveland, Ohio 44135

and

E.J. Mularz  
Propulsion Directorate  
U.S. Army Aviation Research and Technology Activity - AVSCOM  
Lewis Research Center  
Cleveland, Ohio 44135

**ABSTRACT**

→ A versatile planar reacting shear layer (PRSL) facility is constructed at NASA Lewis Research Center. This paper describes the research objectives, as well as design, instrumentations and the operational procedures developed for the system. The fundamental governing equations and the type of quantitative information that are needed from experiments are described. Additionally, a review of earlier work is presented. Whenever appropriate, comparisons are made with similar systems in other facilities and the main differences are described. Finally, the nonintrusive measurement techniques; PLIF, PMS, LDV and Schlieren photography, and the type of experiments that are planned are described.

## INTRODUCTION

(cont)

Several recent studies and reviews of current research in turbulent reacting flows have concluded a clear need for additional work in plane free shear layer systems. Although a repertory of literature is available on round free jets, relatively few works are reported on plane free shear layers. At the same time, there is an imperative need for further understanding of the plane mixing layer in order to develop relationships between the existing computational fluid dynamics codes and the experimental results.

For the above reasons and in order to provide an understanding of fluid dynamics-combustion interaction for space and aeronautics projects, a very substantial and versatile planar reacting shear layer (PRSL) system is being designed and built at NASA Lewis Research Center.

The importance of a planar reacting shear layer (PRSL) facility to NASA Lewis Research Center can be described in terms of space and aeronautics applications. For space applications, there is a need for development of methods to predict low thrust propulsion systems in terms of specific impulse and wall heat transfer as two examples. The design methodology of large rocket motors poorly predicts low thrust systems. For instance the hydrogen oxygen mixing layer of thruster can be simulated with a PRSL system (Fig. 1).

For aeronautics applications (i.e., high-speed propulsion), a PRSL system would make it possible to examine the effect of acoustic waves and the effect of combustion on mixing (e.g., gas temperature rise) and engine nozzles performance, as well as the effect of mixing on combustion intensity (Fig. 2). Additional benefits of this facility include the capability to conduct



pressure data by using a downstream nozzle to determine the effects of oscillating pressure field on shear layers.

### Background and Early Studies

As stated earlier the available literature on plane free shear layers is comparatively limited and what is available is, in most part, restricted to simple turbulent flows with no chemical reactions. Furthermore, virtually all of these studies are limited to simple geometries without the complication of radiative heat transfer and multiple phases. It is further understood that the above complications can and will have profound and drastic effects on the final outcome and therefore limit the degree of suitability of the results of those simpler studies.

Among the works on turbulent reaction in plane free shear layers, under the fast reaction limit studies,<sup>1</sup> Mungal, et al.<sup>2</sup> studied a shear layer in a duct with dilute hydrogen/fluorine in nitrogen or helium under the conditions of  $Re_x = 4 \times 10^5$  and 132 K maximum temperature rise. Koochesfahani and Dimotakis<sup>3</sup> also investigated a shear layer in a duct with dilute acid/base reaction in water. They used  $H_2SO_4$  and NaOH with a time-resolved LIF visualization along a line crossing the flow. Batt<sup>4</sup> investigated a wall jet in still air via dilute nitrogen tetroxide dissociation. Wallace<sup>5</sup> studied shear layer in a duct with dilute nitric oxide/ozone in helium, nitrogen or argon. Also, many studies<sup>6</sup> are reported on means to control shear layers. These are mostly controlled excitation techniques applied to nonreacting shear layers with very promising results.

## SYSTEMS DESCRIPTION

The planar reacting shear layer features a continuous flow under high subsonic velocity conditions and high heat release. Figure 3 depicts the overall schematic of the system. In order to distinguish the different features of this facility, the description that follows is divided into three sections, namely: (1) the PRSL Test Section, (2) the Laser Diagnostics and Pressure Waves Instrumentation System, and (3) the Image Acquisition and Processing System.

### PRSL Test Section

The cross section of the test section is 10.2 by 20.4 cm at the location of the knife edge (Fig. 4). The height (20.4 cm) is large in order to keep the shear layer from being influenced by the boundary layers on the wall. The interaction between  $N_2$ ,  $H_2$ , and heated air (867 K) begins at the knife edge. This section is preceded by screens and a honeycomb section for fuel and air. The reacting shear layer discharges into a larger chamber and passes over several water-cooled back pressure tubes (Fig. 5). These tubes are removable in part or in their entirety. Microphone pressure taps are placed along the upper and lower sides of the test section in order to investigate the fluctuating pressure field. For nonintrusive measurements, laser sapphire windows are constructed on the sides. Sapphire is a superior window material because of its extreme surface hardness, high electric constant, high thermal conductivity and resistance to most chemical acids and alkalis. Because of their structural strength, sapphire windows can be made much thinner than other materials. Chemically, sapphire is a single crystal aluminum oxide ( $Al_2O_3$ ) and exhibits high internal light transmittance from 150 to 6000 nm. The upper

and lower walls are moveable in order to be able to impose a desired axial pressure gradient.

### Laser Diagnostics

The most important tasks are to identify the instantaneous structure of the flowfield, the location of the burning zones and the effect of finite-rate chemistry. It should be noted that although planar shear layer is the simplest shear layer geometry and is well suited for modelling purposes (through numerical computations), it is experimentally difficult to implement.

The following factors are of paramount importance in choosing diagnostic systems:

I. Instantaneous structure of mixing zones. - Mixing begins to occur as the fuel and oxidizer (air) come together at the knife edge. This process cannot be inferred from time-averaged concentration measurements since those techniques can only depict an overall picture of the mixing process. A more detailed knowledge of the mixing process and the flowfield can be obtained by measurements of the instantaneous concentration field. This understanding can be further enhanced by a juxtaposition of the instantaneous velocity and pressure fields.

II. Location of burning zones. - A detailed study of burning zones is essential in order to construct a relationship between the temperature fields and the local velocity fields. Also, it is equally important to investigate the differences between burning under supersonic and subsonic conditions.

III. Effect of finite-rate chemistry. - It is anticipated that the Damkohler number (mixing time/chemical reaction time) would be small in certain regions of the flow.<sup>2</sup> This finite-rate chemistry may play a significant role in supersonic combustion. The required information on the effect of finite-rate chemistry may be obtained by measurement of intermediate and product species as well as temperature.

V. Two-component LDV measurement. - A two-component (four-beam) LDV system is used to make point-measurement of the time-evolved velocity fluctuations inside the flowfield. In order to obtain a high-intensity scattered signal for high signal to noise ratio, a 3.75x beam expander and forward scattering are used. However, this reduces the possibility of particle detection and decreases the data rate.

#### Conventional Instrumentations and Advanced Diagnostics

LDV, pressure probe and Schlieren photography are among the conventional instrumentations that will be used for measurements that are described above. Among the advanced diagnostic techniques, planar laser induced fluorescence (PLIF) will be used for measurements of the instantaneous concentration, temperature, velocity and pressure fields. Also, planar Mie scattering (PMS) will be used to obtain the instantaneous physical image. Figure 6 is a chart showing the schematics of different PLIF systems and their applications for temperature and concentration measurements. Other schematics on the chart are velocity and pressure imaging and PMS systems. Figure 7 is a schematic of the location of the laser sheet in the facility. The motivations for performing LDV measurements are to obtain time-averaged reacting flow data of the shear layer (e.g., mean and root mean square  $U$  and  $V$  throughout the flowfield)

as a benchmark for comparison with computation models, and secondly, to examine the effect of oscillating pressure field on shear layer through the cross-correlations of instantaneous pressure and velocity, Table 1.<sup>9</sup> As mentioned earlier, the objectives are to obtain time-dependent data of mean and turbulence quantities as well as images for comparison with predictions.

In order to increase the data rate and obtain high-density data, a reactive-type seeder is used to generate seed density of about one,  $0.3 \mu\text{m}$  diameter  $\text{TiO}_2$ , particle per cubic millimeter. These particles are formed from the reaction of small droplets of titanium-tetrachloride and steam. In case the scatter cross section of titanium dioxide becomes too small within the high temperature gas, trimethyl-aluminum can be used as a direct substitute for titanium-tetrachloride. The formed alumina particles are quite stable in high temperature conditions. This chemical particle generation method yields a more even distribution and higher density than the dry fluidized bed seeders.

#### Image Acquisition and Processing System

A schematic diagram of the imaging system is illustrated in Fig. 8. This system is comprised of a host computer, an image processing subsystem, image acquisition hardware and data analysis and reduction components. The cameras are of the gated intensified solid-state CCD monochrome video camera and can be triggered externally. PLIF requires one camera for concentration measurements and two cameras for temperature measurements. Velocity measurements require two cameras for one-dimensional and four cameras for two-dimensional measurements. Also, since the fluorescence intensity is too low to be measured directly, a UV-enhanced microchannel plate (MCP) image intensifier is internally bonded to the CCD imaging array via an optical fiber bundle. This

system offers 488(V) by 754(H) pixel frame, 30 frames/sec. An image subsystem that controls a video tape recorder through an animation controller is used to acquire images. For image processing and analysis, single video frames will be acquired from the previously recorded tape and will be fed into the image subsystem.

The host computer is a Concurrent 5600 (Fig. 9). The operating system is a real-time enhanced UNIX system (RTU 4.0) that is compatible with AT&T System V and Berkely 4.2 BSD.

## THEORY AND COMPUTATIONS

### The Large Scale Coherent Structure and Initial Condition Effects

The PRSL is a two-dimensional planar variable-density flow system. It should be noted that the term two-dimensional is solely descriptive of the system geometry as any turbulent flowfield is intrinsically three-dimensional in nature. As such, the large-scale structures play an important role in the mixing process. In round jets, density variations occur in regions downstream of the flow and decrease with increase in the axial distance. On the other hand, two-dimensional shear layers offer the advantage of providing density differences farther downstream (i.e., a longer mixing region). Therefore, any modeling attempt should incorporate the effects of large scale structures on the mixing process. Zaman and Hussain<sup>6</sup> have summarized the results of their studies on natural large-scale structures in the axisymmetric mixing layer. They have also made comparisons between the natural structure and the structure induced by controlled excitation. Among their findings, they report that the natural structures were independent of  $Re_D$  over a range of

$5.5 \times 10^4 \leq Re_D \leq 8 \times 10^5$ . The educed structures for the natural and excited cases are very similar except at higher amplitudes where excitation can noticeably affect the structures. For the analytical formulation on the treatment of the coherent and incoherent flowfields, the reader may consult Ref. 6.

Zaman and Hussain also report a mild dependence on the initial boundary layer condition with laminar boundary layer producing more disorganized structures. This latter finding is also supported by Clark.<sup>7</sup> Hussain and Zaman<sup>11</sup> show the contours of coherent spanwise vorticity at different stages of the structure evolution in a plane mixing layer (Fig. 10); the last station corresponds to a Reynolds number of  $Re_x \approx 2 \times 10^6$ . The contours are plotted as a function of the transverse distance and the time. The authors note that while the structure shape changes between  $x = 150$  and  $300 \theta_e$ , the change in the nondimensional vorticity is not significant. They also observe that similar coherent vorticity-contour details suggest achievement of an "equilibrium" state which persists for the entire length of plane mixing layer.<sup>11</sup>

#### Effect of Heat Release on Turbulent Flowfield

Farshchi<sup>8</sup> recently extended a fully second-order closure model for reacting turbulent flows in order to include the effects of heat release on turbulent flowfield. He analyzed the exact pressure equation of a turbulent nonpremixed flame. His completely modelled scalar dissipation equation is:

$$\begin{aligned}
 a_i(\bar{\rho} \tilde{u}_j \epsilon_f) = & a_j (C_{C2} \bar{\rho} \frac{k}{\epsilon} \widetilde{u_i'' u_j''} a_i \epsilon_f) - C_{p2} \bar{\rho} \frac{\epsilon}{k} \widetilde{u_i'' u_j''} a_j \tilde{u}_i + C_{p3} \bar{\rho} \tilde{\rho} (f_s; \underline{x}) \epsilon_f^2 \frac{1}{f''^2} (\tilde{f}''^2)^{1/2} \\
 & - C_{D1} \bar{\rho} \frac{\epsilon_f^2}{f''^2} - C_{D2} \bar{\rho} \epsilon_f \frac{\epsilon}{k} - C_{D3} \frac{1}{\rho} \overline{(d_{fp})^2} \epsilon_f^2 - C_{p1} \bar{\rho} \frac{\epsilon_f}{f''^2} \widetilde{u_j'' f''} a_j \tilde{f}
 \end{aligned}$$

The 23 constants in the above equation are:

$C_s = 0.2$	$C_1 = 1.6$	$C_2 = 0.43$	$C_{R1} = 1.25$	$C_e = 0.15$
$C_{e1} = 1.45$	$C_{e2} = 1.90$	$C_{e3} = 1.0$	$C_{R2} = 1.25$	$C_{1RU} = 4.0$
$C_{2RU} = 0.5$	$C_{RF} = 1.25$	$C_{RUD} = 1.0$	$C_C = 0.18$	$C_{1C} = 3.2$
$C_{2C} = 0.5$	$C_{C2} = 0.18$	$C_{D1} = 2.2$	$C_{D2} = 0.8$	$C_{D3} = 1.0$
$C_{p1} = 1.8$	$C_{p2} = 0.8$	$C_{p3} = 1.0$		

Farshchi made comparisons with limited experimental results but noted that further experiments are needed to support or to improve his assumptions. He specifically suggested comprehensive measurements of quantities such as mixture fraction, density variances and scalar-velocity correlations. These fall exactly within the scopes and objectives that are planned for the PRSL system.

The modeled Reynolds stress equation<sup>10</sup> for the case of heat release with the assumption of local isotropy at high Reynolds numbers is as follows:

$$\begin{aligned}
 a_i(\bar{\rho} \tilde{u}_i \widetilde{u_i'' u_j''}) = & -(\bar{\rho} \widetilde{u_i'' u_j''} a_i \tilde{u}_i + \bar{\rho} \widetilde{u_i'' u_i''} a_i \tilde{u}_j) - \frac{2}{3} \bar{\rho} \epsilon \delta_{ij} \\
 & + a_i [c_5 \bar{\rho} \frac{k}{\epsilon} \widetilde{u_i'' u_m''} a_m (\widetilde{u_i'' u_j''})] + \frac{1}{\rho} (\overline{\rho' u_i''} a_j \bar{\rho} + \overline{\rho' u_j''} a_i \bar{\rho}) + Q_{ij}^1 + Q_{ij}^2
 \end{aligned}$$

where  $Q_{ij}^1$  represents the correlation of the velocity fluctuations with the hydrodynamics part of the pressure fluctuation gradient and  $Q_{ij}^2$  represents the heat release part of the pressure-strain rate correlation.<sup>10</sup>

Measurement of the kinetic energy term ( $k$ ) is of particular importance since it identifies the level of turbulence. As such, the following quantities are of primary importance:

$$\widetilde{u''}, \quad \widetilde{u''_i u''_j}, \quad k, \epsilon, \quad \overline{\rho' u''}$$

#### CONCLUDING REMARKS

A detailed description of a versatile planar reacting shear layer system, under construction at NASA Lewis Research Center, is provided. The motivations and objectives for the design and the type of quantitative information that are needed from experiments are described. State-of-the-art diagnostic systems incorporated in the PRSL system and their interrelations are discussed. Finally, a synopsis of the theory and the required computations is provided which includes the effect of large scale structures, influence of the initial boundary layer conditions, effect of excitation amplitude on the structures and the effect of heat release on the turbulent flowfield. The PRSL system would enable researchers to develop relationships between the existing CFD codes and the experimental results to further explore fluid dynamics/combustion interaction for space and aeronautics projects.

## NOMENCLATURE

$f$	mixture fraction, $f = \tilde{f} + f''$
$k$	kinetic energy of turbulence ( $1/2 \overline{u_i u_i}$ )
$\tilde{P}$	Favre probability density function
$p$	fluctuating pressure
$Re$	Reynolds number
$U, V$	mean velocity components
$u, v, w$	fluctuating velocity components
$\underline{x}$	position vector
$x, y, z$	streamwise, transverse and spanwise coordinates
$\epsilon$	rate of dissipation
$\epsilon_f$	scalar variance dissipation rate
$\nu$	kinematic viscosity
$\rho$	fluid density
$(\bar{\quad})$	conventional averaging
$(\tilde{\quad}), (\langle \quad \rangle)$	density weighted averaging

## ABBREVIATIONS

CFD	computational fluid dynamics
LIF	laser induced fluorescence
LDV	laser doppler velocimeter
MCP	microchannel plate
PDA	photodiode array
PLIF	planar laser induced fluorescence
PMS	planar mie scattering
PRSL	planar reacting shear layer

## REFERENCES

1. Strahle, W.C. and Lekoudis, S.G.: Evaluation of Data on Simple Turbulent Reacting Flows, AFOSR-TR-85-0880, Sept. 1985 (Avail. NTIS, AD-A170071).
2. Mungal, M.G., Hermanson, J.C., and Dimotakis, P.E.: AIAA J. 23, 1418 (1985).
3. Koochesfahani, M.M. and Dimotakis, P.E.: AIAA J. 23, 1700 (1985).
4. Batt, R.G.: J. Fluid Mech. 82, 53 (1977).
5. Wallace, A.K.: Experimental Investigation on the Effects of Chemical Heat Release in the Reacting Plane Shear Layer. Ph.D. Thesis, California Institute of Technology, Pasadena, CA, 1981 (Avail. NTIS, AD-A144482).
6. Zaman, K.B.M.Q. and Hussain, A.K.M.F.: J. Fluid Mech. 138, 325 (1984).
7. Hussain, A.K.M.F. and Clark, A.R.: J. Fluid Mech. 104, 263 (1981).
8. Farshchi, M.: Prediction of Heat Release Effects on a Mixing Layer. AIAA Paper 86-0058, 1986.
9. Rodi, W.: Studies in Convection (B.E. Launder, Ed.), Vol. 1, p. 79, Academic Press, 1975.
10. Rodi, W.: Basic Equations for Turbulent Flow in Cartesian and Cylindrical Coordinates. Imperial College, Mech. Eng. Dept., London, Report BL/TN/A/36, 1970.
11. Hussain, A.K.M.F. and Zaman, K.B.M.Q.: J. Fluid Mech. 159, 85 (1985).

TABLE I. - DESIRABLE QUANTITIES FOR MEASUREMENT<sup>11</sup>

Group	1	2				3							
	Mean flow	Reynolds stresses				Other correlations							
Quantity	U	$\overline{uv}$	k			$\epsilon$	$\overline{u^2v}$	$\overline{v^3}$	$\overline{vw^2}$	$\overline{vp}$	$\overline{uv^2}$	$\overline{up}$	$\rho \left( \frac{\partial u}{\partial y} + \frac{\partial v}{\partial x} \right)$
			$\overline{u^2}$	$\overline{v^2}$	$\overline{w^2}$								
Equations in which it appears	Mom	Mom	Mom	Mom	-	-	-	-	-	-	--	--	--
	k	k	k	k	k	k	k	k	k	k	--	--	--
	$\overline{uv}$	$\overline{uv}$	---	$\overline{uv}$	-	-	-	-	-	-	$\overline{uv}$	$\overline{uv}$	$\overline{uv}$

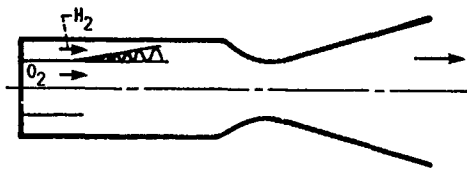

FIGURE 1. - HYDROGEN-OXYGEN MIXING LAYER OF THRUSTER CAN BE WELL SIMULATED WITH A PRSL FACILITY.

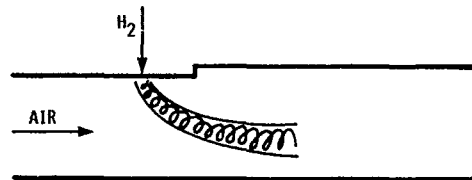

FIGURE 2. - HYDROGEN FUEL JET WITH AIR CROSSFLOW MIXING IS SIMULATED IN A 2-D PLANE SHEAR LAYER.

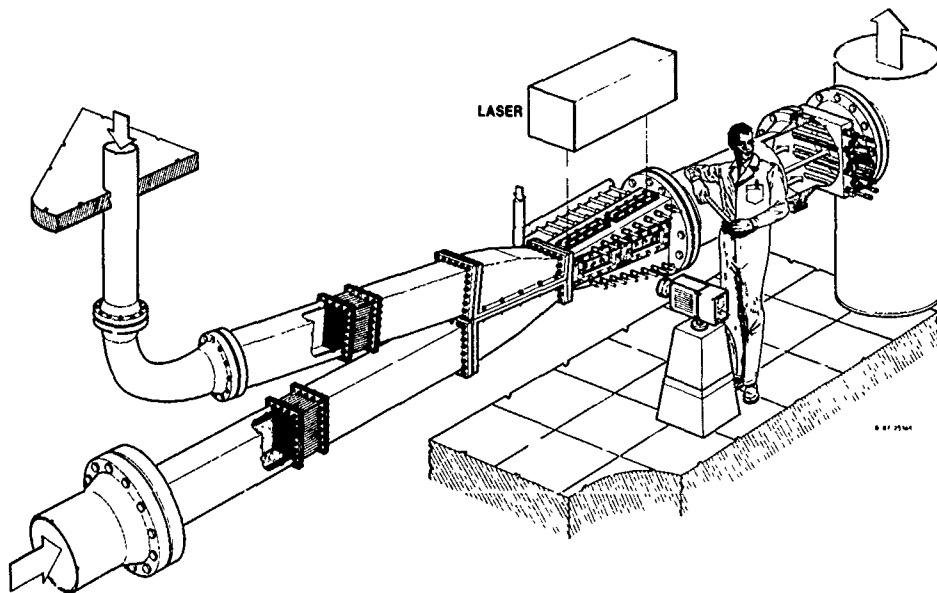

FIGURE 3. - A SCHEMATIC OF THE PRSL FACILITY.

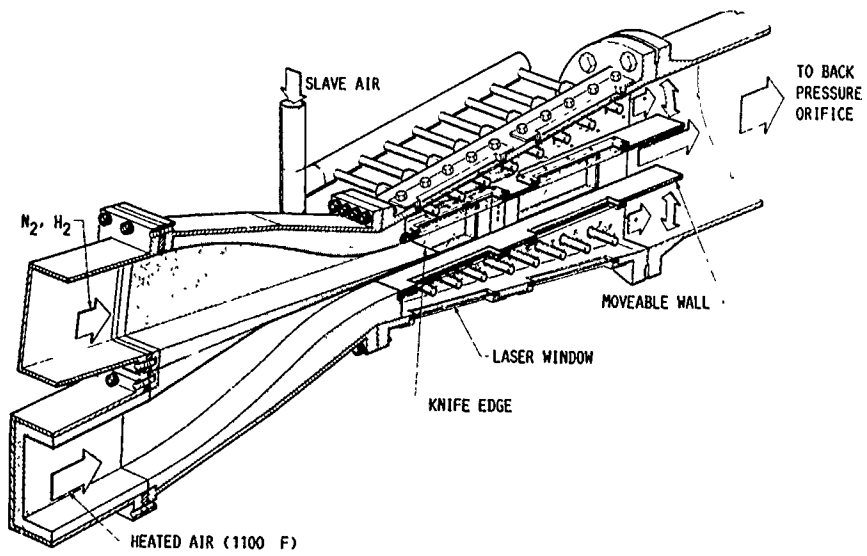

FIGURE 4. - PRSL TEST SECTION.

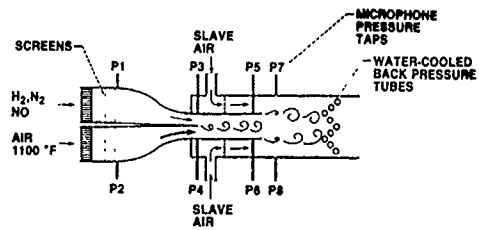

FIGURE 5. - MICROPHONE LOCATIONS (PRSL TEST SECTION).

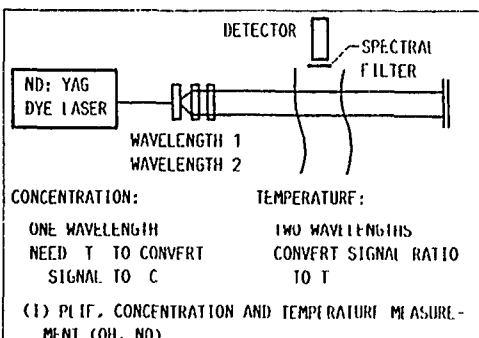
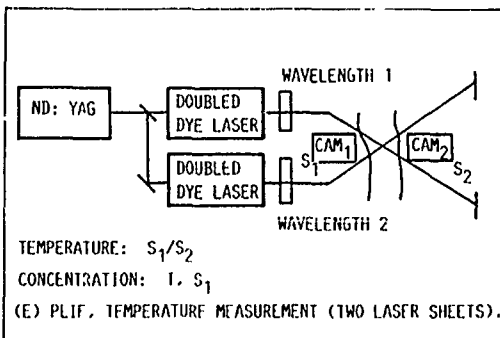
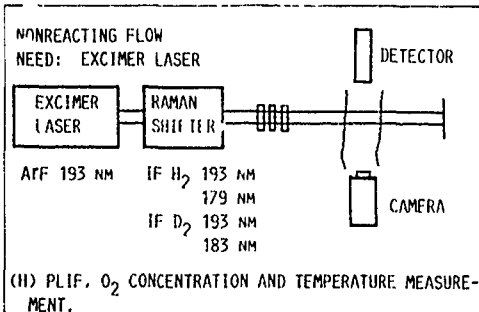
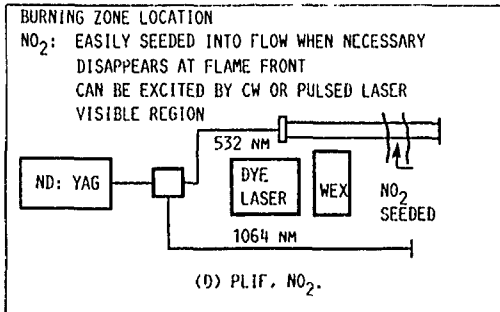
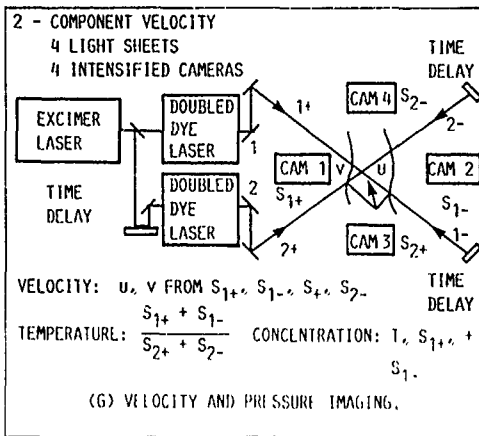
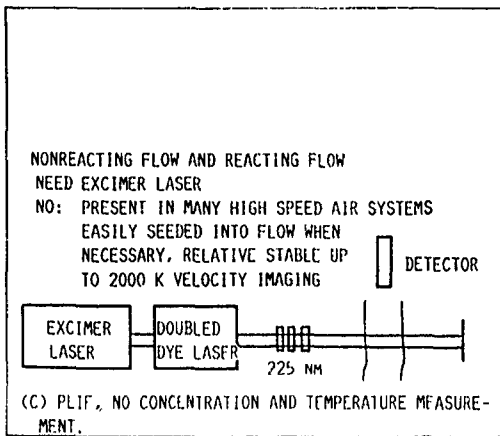
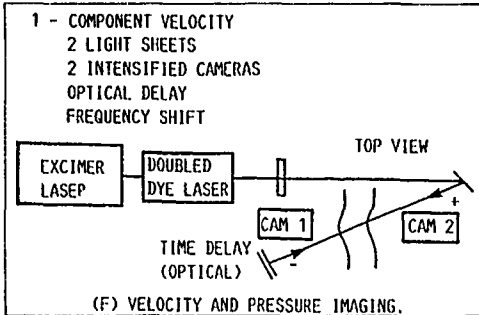
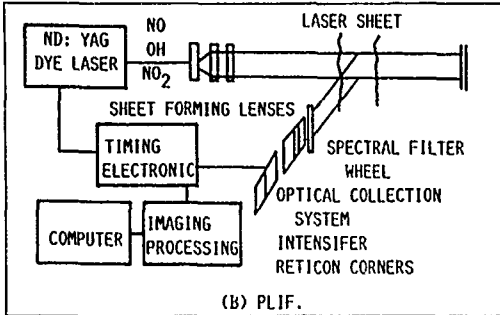
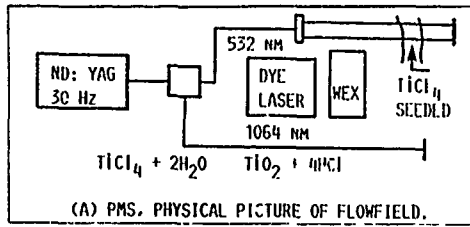

FIGURE 6. - INSTRUMENTATIONS AND ADVANCED DIAGNOSTIC TECHNIQUES.

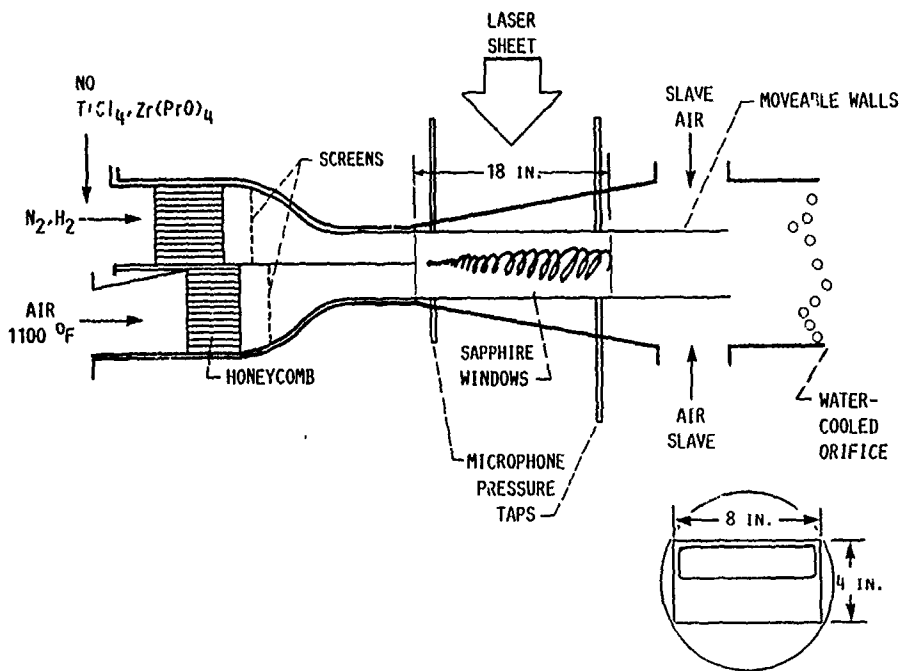

FIGURE 7. - LOCATION OF THE LASER SHEET IN THE FACILITY.

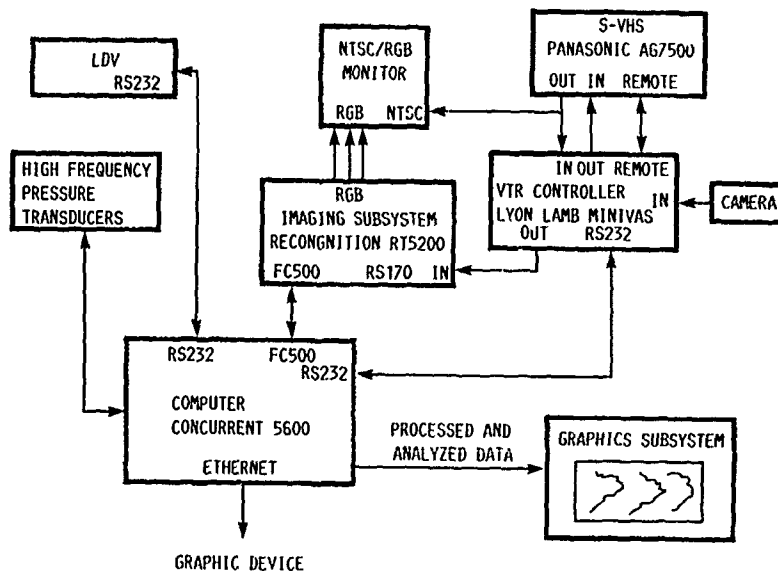

FIGURE 8. - PRSL IMAGING SYSTEM FLOW CHART.

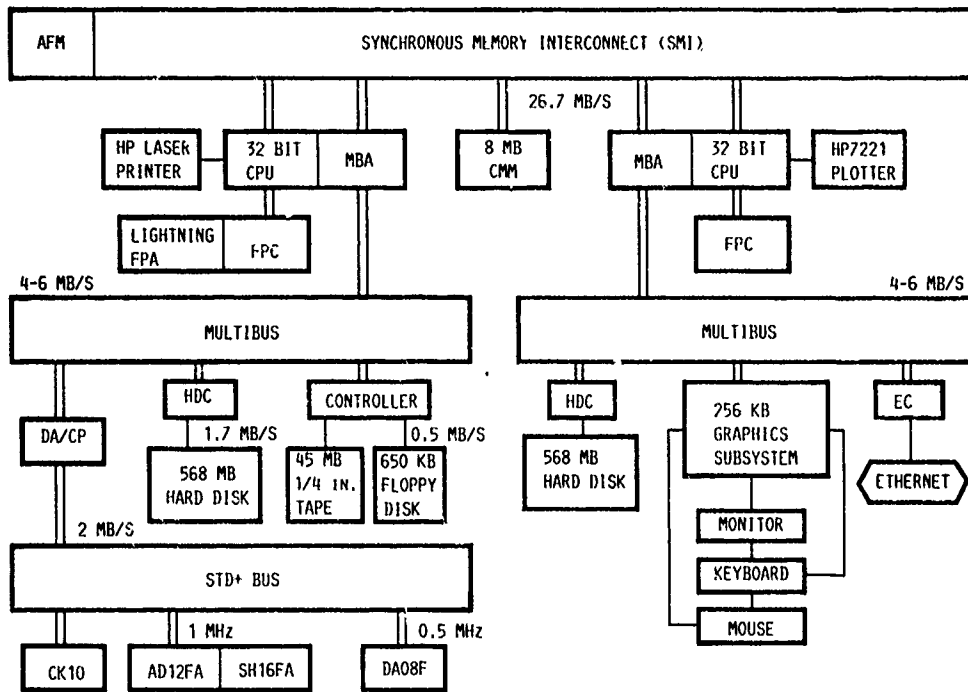

FIGURE 9. - CONCURRENT 5600.

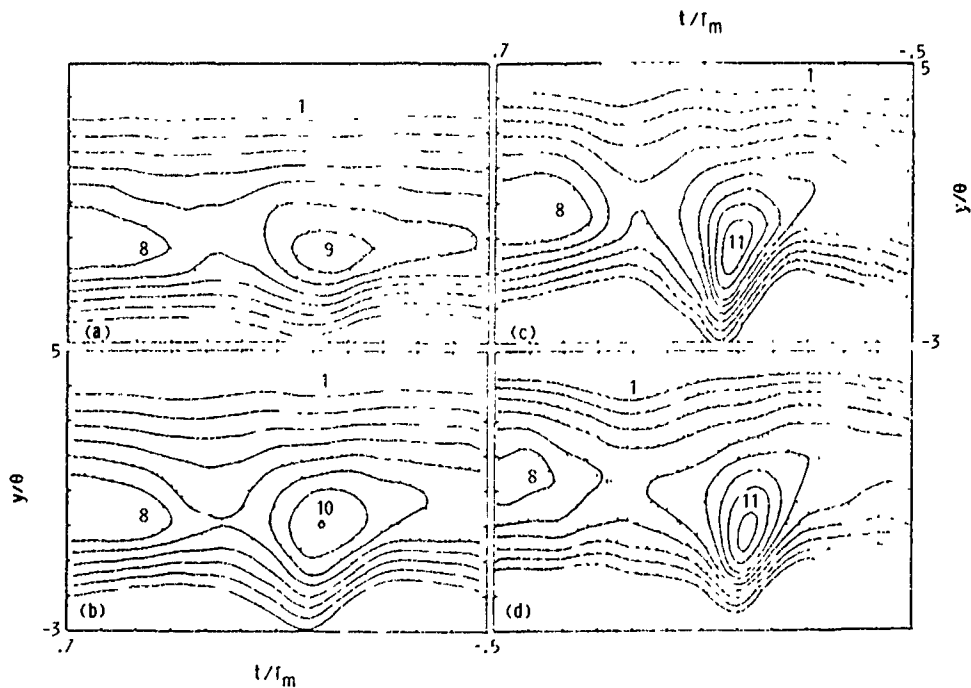

FIGURE 10. -  $-D_z$  CONTOURS AT: (a)  $\times 150 \theta_0$ , (b)  $300 \theta_0$ , (c)  $600 \theta_0$  AND (d)  $4800 \theta_0$  FROM REF. 11.



# Report Documentation Page

1. Report No. NASA TM-102422 AVSCOM TR 89-C-013		2. Government Accession No.		3. Recipient's Catalog No.	
4. Title and Subtitle A Planar Reacting Shear Layer System for the Study of Fluid Dynamics- Combustion Interaction				5. Report Date	
				6. Performing Organization Code	
7. Author(s) C.J. Marek, C.T. Chang, B. Ghorashi, C.C. Wey, C. Wey, and E.J. Mularz				8. Performing Organization Report No. E-5063	
9. Performing Organization Name and Address NASA Lewis Research Center Cleveland, Ohio 44135-3191 and Propulsion Directorate U.S. Army Aviation Research and Technology Activity—AVSCOM Cleveland, Ohio 44135 3127				10. Work Unit No. 505-62-21 1L161102AH45 ✓	
				11. Contract or Grant No.	
12. Sponsoring Agency Name and Address National Aeronautics and Space Administration Washington, D.C. 20546-0001 and U.S. Army Aviation Systems Command St. Louis, Mo. 63120-1798				13. Type of Report and Period Covered Technical Memorandum	
				14. Sponsoring Agency Code	
15. Supplementary Notes Prepared for the 23rd International Symposium on Combustion sponsored by The Combustion Institute, University of Orléans, France, July 22-27, 1990. C.J. Marek and C.T. Chang, NASA Lewis Research Center; B. Ghorashi and C.C. Wey, Cleveland State University, Cleveland, Ohio 44115; C. Wey, Sverdrup Technology, Inc., NASA Lewis Research Center Group, Cleveland, Ohio 44135. E.J. Mularz, Propulsion Directorate, U.S. Army Aviation Research and Technology Activity—AVSCOM.					
16. Abstract A versatile planar reacting shear layer (PRSL) facility is constructed at NASA Lewis Research Center. This paper describes the research objectives, as well as design, instrumentations and the operational procedures developed for the system. The fundamental governing equations and the type of quantitative information that are needed from experiments are described. Additionally, a review of earlier work is presented. Whenever appropriate, comparisons are made with similar systems in other facilities and the main differences are described. Finally, the noninvasive measurement techniques; PLIF, PMS, LDV and Schlieren photography, and the type of experiments that are planned are described.					
17. Key Words (Suggested by Author(s)) Hydrogen Shear flow Acoustics			18. Distribution Statement Unclassified—Unlimited Subject Category 07		
19. Security Classif. (of this report) Unclassified		20. Security Classif. (of this page) Unclassified		21. No of pages 20	22. Price* A03