

AD-A240 347

2



NAVAL POSTGRADUATE SCHOOL Monterey, California

S DTIC
ELECTE
SEP 12 1991
D



THESIS

DEVELOPMENTAL FLIGHT TESTING
OF A HALF SCALE
UNMANNED AIR VEHICLE

by

James Dale Salmons

September 1990

Thesis Advisor:

Richard M. Howard

Approved for public release; distribution is unlimited.

91-10353

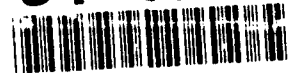

91 10353

REPORT DOCUMENTATION PAGE

1a REPORT SECURITY CLASSIFICATION UNCLASSIFIED		1b RESTRICTIVE MARKINGS	
2a SECURITY CLASSIFICATION AUTHORITY		3 DISTRIBUTION/AVAILABILITY OF REPORT Approved for public release; distribution is unlimited	
2b DECLASSIFICATION/DOWNGRADING SCHEDULE			
4 PERFORMING ORGANIZATION REPORT NUMBER(S)		5 MONITORING ORGANIZATION REPORT NUMBER(S)	
6a NAME OF PERFORMING ORGANIZATION Naval Postgraduate School	6b OFFICE SYMBOL (if applicable) AA	7a NAME OF MONITORING ORGANIZATION Naval Postgraduate School	
6c ADDRESS (City, State, and ZIP Code) Monterey, CA 93943-5000		7b ADDRESS (City, State, and ZIP Code) Monterey, CA 93943-5000	
8a NAME OF FUNDING/SPONSORING ORGANIZATION	8b OFFICE SYMBOL (if applicable)	9. PROCUREMENT INSTRUMENT IDENTIFICATION NUMBER	
8c ADDRESS (City, State, and ZIP Code)		10 SOURCE OF FUNDING NUMBERS	
		PROGRAM ELEMENT NO.	PROJECT NO.
		TASK NO.	WORK UNIT ACCESSION NO.
11. TITLE (Include Security Classification) DEVELOPMENTAL FLIGHT TESTING OF A HALF SCALE UNMANNED AIR VEHICLE			
12 PERSONAL AUTHOR(S) Salmons, James, D.			
13a TYPE OF REPORT Master's Thesis	13b TIME COVERED FROM _____ TO _____	14 DATE OF REPORT (Year, Month, Day) September 1990	15 PAGE COUNT 64
16 SUPPLEMENTARY NOTATION The views expressed in this thesis are those of the author and do not reflect the official policy or position of the Department of Defense or the U.S. Government			
17 COSATI CODES		18 SUBJECT TERMS (Continue on reverse if necessary and identify by block number)	
FIELD	GROUP	SUB-GROUP	
19 ABSTRACT (Continue on reverse if necessary and identify by block number) Developmental flight test of a half scale unmanned air vehicle was conducted for the purpose of predicting the longitudinal and lateral-directional behavior of the full scale vehicle. Instrumentation was developed and installed in the radio controlled aircraft. The instrumentation allowed for the measurement and recording of control surface movement, indicated airspeed, sideslip angle and angle of attack. The measurement system operated successfully; the data recording system suffered limitations due to the vibration introduced into the airframe by the propeller and engine. Lateral-directional data were obtained from steady sideslip maneuvers, but longitudinal data taken for trimmed flights with varied center-of-gravity positions were unusable. The data were compared to available full scale information. Further flight tests are required to build a larger data base to estimate the behavior of the full scale Pioneer.			
20 DISTRIBUTION/AVAILABILITY OF ABSTRACT <input checked="" type="checkbox"/> UNCLASSIFIED/UNLIMITED <input type="checkbox"/> SAME AS RPT <input type="checkbox"/> DTIC USERS		21. ABSTRACT SECURITY CLASSIFICATION UNCLASSIFIED	
22a NAME OF RESPONSIBLE INDIVIDUAL Richard M. Howard		22b TELEPHONE (Include Area Code) 408-646-2870	22c OFFICE SYMBOL Code AA Ho

Approved for public release; distribution is unlimited.

DEVELOPMENTAL FLIGHT TESTING
OF A HALF SCALE
UNMANNED AIR VEHICLE

by

James Dale Salmors
Lieutenant, United States Navy
B.S., Texas A&M University, 1982

Submitted in partial fulfillment
of the requirements for the degree of

MASTER OF SCIENCE IN AERONAUTICAL ENGINEERING

from the

NAVAL POSTGRADUATE SCHOOL

September 1990

Author:

James Dale Salmors

Approved by:

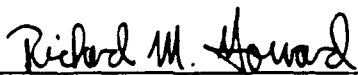
Richard M. Howard, Thesis Advisor

Eric L. Pagenkopf, Second Reader

E. Roberts Wood, Chairman
Department of Aeronautics and Astronautics

ABSTRACT

Developmental flight test of a half scale unmanned air vehicle was conducted for the purpose of predicting the longitudinal and lateral-directional behavior of the full scale vehicle. Instrumentation was developed and installed in the radio controlled aircraft. The instrumentation allowed for the measurement and recording of control surface movement, indicated airspeed, sideslip angle and angle of attack. The measurement system operated successfully; the data recording system suffered limitations due to the vibration introduced into the airframe by the propeller and engine. Lateral-directional data were obtained from steady sideslip maneuvers, but longitudinal data taken for trimmed flights with varied center-of-gravity positions were unusable. The data were compared to available full scale information. Further flight tests are required to build a larger data base to estimate the behavior of the full scale Pioneer.

Accession For	
NTIS CRA&I	<input checked="" type="checkbox"/>
DTIC TAB	<input type="checkbox"/>
Unannounced	<input type="checkbox"/>
Justification	
By	
Distribution/	
Availability Codes	
Dist	Avail. and/or Special
A-1	

TABLE OF CONTENTS

I. INTRODUCTION	1
II. PIONEER BACKGROUND	4
A. NAVY/MARINE ACQUISITION	4
B. DEPLOYMENT	5
C. POSTGRADUATE SCHOOL INVOLVEMENT	7
III. MODIFICATIONS	9
A. GENERAL INSTRUMENTATION	9
B. CONTROL-SURFACE DEFLECTION	9
C. AIRSPEED INDICATOR	10
D. ALPHA-BETA PROBE	12
E. POWER SUPPLY	13
F. RECORDING SYSTEM AND DATA PLAYBACK	14
IV. EXPERIMENTAL PROCEDURES	15
A. VIBRATION ANALYSIS	15
1. ENGINE RUBBER MOUNTS ..	15

2.	FUSELAGE ACCELEROMETER TEST	16
3.	SHAKER TEST OF FUSELAGE MOCKUP	18
4.	TEST OF SUSPENSION SYSTEM IN THE AIRCRAFT	21
5.	ELECTRICAL CONNECTIONS	23
B.	FLIGHT TESTING	23
1.	STEADY SIDESLIPS	23
2.	CENTER OF GRAVITY CHANGES	24
C.	DATA REDUCTION EQUIPMENT	25
1.	CALIBRATION OF THE PLAYBACK SYSTEM	26
V.	FLIGHT TEST RESULTS	28
A.	STEADY SIDESLIP TESTS	28
B.	CHANGING C.G. TESTS	33
C.	GROUND TEST	35
VI.	RECOMMENDATIONS	36
APPENDIX A:	DATA	38
APPENDIX B:	SCHEMATICS	46
APPENDIX C:	FLIGHT TEST SHEETS	50

LIST OF REFERENCES 55

INITIAL DISTRIBUTION 56

I. INTRODUCTION

Dr. Edward Teller, father of the nuclear age, said "The unmanned vehicle of today is akin to the importance of radar and computer in 1935". [Ref. 1:p. 12]

The uses that an Unmanned Air Vehicle (UAV) can be put to are not new lessons. In 1952 pictures of the USS Iowa were taken from a UAV with a simple video camera [Ref. 2:p. 87]. Then in the Vietnam era UAV's were once again employed. In Vietnam the UAV's were used for reconnaissance of the enemy. This use of UAV's reduced the number of pilots being lost to hostile fire by reducing the number of manned reconnaissance flights. The UAV's of this time period were almost as large as piloted aircraft and flew approximately as fast [Ref. 3:p. 14]. The next major use of UAV's was by the Israeli military in the Bekaa valley during the first few days of the Lebanon War. The missions were a stunning success, allowing the Israelis to dominate the skies. In this case the UAV's were used not to replace pilots, but as a force multiplier to assist pilots in carrying out the assigned mission. To do this a UAV called the Sampson was used as a decoy. It was launched by an F-4 and glided in at high speeds emitting the radiation that characterizes an Israeli aircraft. A second F-4 followed and launched an antiradiation missile when the Syrian defenders activated the air defenses to shoot the decoys.

At this date the US services are experimenting with UAV's and have a few operational detachments. The US Congress has appropriated funds for the continued

research on UAV's. Some of the vehicles that have been investigated or are being investigated are Amber, Condor, Pointer and Sentinel. Long-endurance vehicles like the Amber and Condor are being studied to gather data in the atmosphere and also by the military for use as observation aircraft. Short range vehicles are being investigated for use by the commander in the field by the US Army and Marine Corps. UAV's are also finding uses outside the military services. NASA has used a UAV called the HIMAT (Highly Maneuverable Aircraft Technology) for research in high-risk technologies. Tests with these small-scale, unmanned models are more economical [Ref. 4: p.18].

The scope of this thesis was to perform developmental flight testing of a half scale unmanned air vehicle. To do this the half scale version of the Pioneer used by the US Marine Corps for training was chosen as the airframe to instrument. This airframe was chosen because of problems that the Unmanned Air Vehicle Office at the Pacific Missile Test Center (PMTTC) had identified in the full scale version of the Pioneer. The problems included 1) discrepancies in the predicted and flight tested rate-of-climb, time-to-climb and fuel flow at altitude; 2) apparent autopilot-related pitch instability; 3) tail boom structural failure; 4) severely limited lateral control; 5) slow pitch response causing degraded maneuverability at high gross weights; and 6) insufficient testing to determine the effects of the new wing on flight endurance.

The half scale Pioneer airframe was instrumented with components to measure airspeed, control surface deflection, angle of attack and side slip angle. The information from these sensors was then used to calculate $d\delta/d\beta$, $d\delta/d\beta$ and the longitudinal characteristic of the aircraft. This information can then be used to estimate the

performance of the full size Pioneer. The information can also be used to compare with earlier computer simulation work done on the Pioneer at the Naval Postgraduate School by Capt. Dan Lyons [Ref. 5;pp. 14-55].

II. PIONEER BACKGROUND

A. NAVY/MARINE ACQUISITION

Two events sparked the US Navy and Marine Corps into obtaining a UAV for operational deployments. The first was a visit by General Kelley to Beirut after the attack on the Marine Headquarters. When Kelley was in Tel Aviv after the attack, the Israelis were reported to have shown him video of his movements in Beirut, at times with the cross hairs of the camera centered on his head. General Kelley is to have said, "I have to buy myself one of those,..." [Ref. 2:p. 84].

The second event was the Naval air strike in the Bekaa valley on Dec 3, 1983 in which two aircraft were lost. US carriers sent 28 aircraft into the Bekaa valley to bomb targets in response to SAM and anti-aircraft fire on F-14 reconnaissance aircraft, even though all the targets of interest were within range of the 16-inch guns on the USS New Jersey. The guns of the USS New Jersey were not used due to the lack of accurate fire control (i.e. visual spotting) [Ref. 2:p. 84]. If there had been a UAV similar to the Pioneer in the battle group, the mission could possibly have been carried out by the New Jersey with a life and two carrier-based aircraft saved. Secretary of the Navy Jonn Lehman then ordered that an off-the-shelf UAV be purchased in July of 1985.

The order to procure a UAV also specified that the contract should be signed in December of 1985. This UAV procurement process was named operation 'Quick Go'. The intent of the procurement order was to get a useable system deployed with the fleet

in a minimum time period. Because of this desire, much of the normal test and evaluation process was bypassed. The Pioneer won the ensuing competition and the procurement contract was signed by January of 1986.

B. DEPLOYMENT

The first Pioneer was delivered to the US Navy for testing in May of 1986. It was operationally deployed on the USS Iowa in December 1986. During this deployment further shipboard testing was carried out while the structural investigation continued at VC-6, NAS Norfolk VA. Four of the first five UAV's deployed on the Iowa were lost. The losses were attributed to possible electromagnetic interference problems and shipboard recovery techniques [Ref. 6:p. 31]. These problems have been corrected and the readiness of the Pioneer system has significantly improved. Since then the New Jersey has received a Pioneer system and four systems have been delivered to the Marine Corps units at Twentynine Palms, CA [Ref. 7:p. 81]. Further orders for the Pioneer UAV systems have been canceled by Congress until a joint plan is arrived at by the military services.

Since the not so auspicious beginning of the Pioneer deployment aboard the Iowa, the system has racked up an impressive mission availability rate. As of July 1989 Pioneer vehicles have logged more than 2,443 hr. during 1,316 flights, for a mission availability of 89.2% [Ref. 7:p.81]. The Marine units have deployed the UAV's on several exercises including an airborne deployment to Morocco. In a single 6- month cruise aboard the USS New Jersey the system flew nearly 80 missions for more than 200 total hours [Ref.

7:p. 81]. During this time the aircraft were used for spotting, battle damage assessment and reconnaissance missions in the North Atlantic, Mediterranean sea, Indian Ocean and the Straits of Hormuz. The Pioneer system was also involved in operation Desert Shield in Saudi Arabia [Ref. 8].

Currently the Pioneer carries one of two payloads. The first is a video camera which has 360 degrees of movement. This camera can be used for daylight missions. The resolution is good enough to be used for identifying and directing fire control at a specified target. The second is a forward-looking infrared sensor (FLIR). The FLIR can be used day or night and has been found to be excellent for spotting. It has detected mines in the Gulf of Hormuz due to the heat from the algae growing on the mines [Ref. 7:p. 81].

Since the Pioneer system was procured without following the normal procurement process, full developmental testing and analysis of the system were not performed. Further testing of the Pioneer system is still under way at PMTC. Currently work is under way to develop a 40% powered scale model of the Pioneer for testing in a wind tunnel. At the same time tactics and deployment doctrine development are ongoing during the deployments. These tests will also identify short comings in design and capability. The data could then be used in follow-on modifications and/or UAV projects.

C. POSTGRADUATE SCHOOL INVOLVEMENT

A half-scale Pioneer used by the Marine Corps for training was acquired in August of 1988 by the Naval Postgraduate School for testing and experimentation. Figure 2.1 is a picture of the airframe that has been utilized at the Naval Postgraduate School.

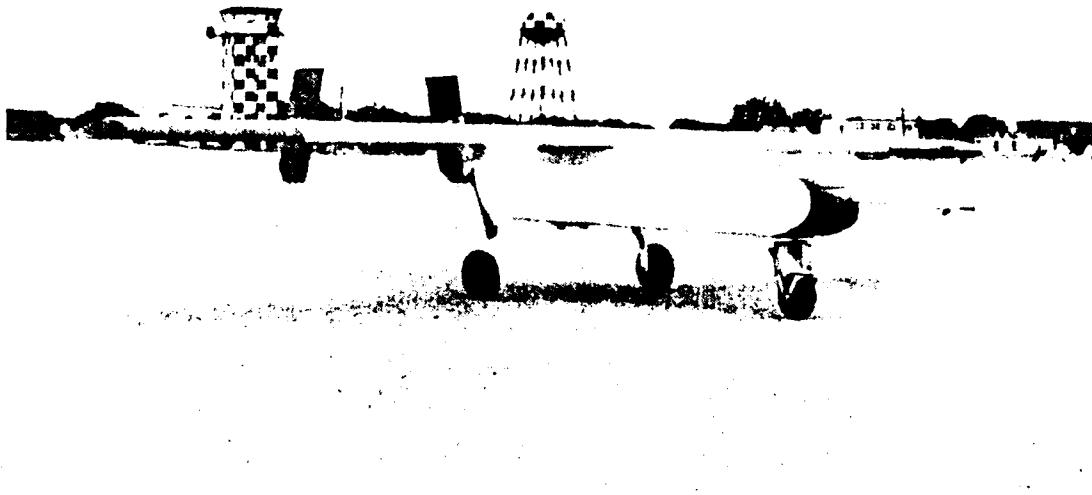

Figure 2.1 Half Scale Pioneer

The testing so far has consisted of collecting power and thrust data to determine the aerodynamic characteristics of the vehicle. Also a numerical model was generated of the full scale Pioneer to estimate stability and control derivatives and to predict the aerodynamic behavior. Testing was started in August 1989 by Lt Jim Tanner, who started

work on determining a drag polar [Ref. 9:pp 49-65]. Major Yeho Kee of the South Korean Air Force continued the drag polar work [Ref. 10:pp 28-34]. Capt. Dan Lyons used a lower-order panel-method computer code in June 1989 to predict performance and flying qualities of the Pioneer [Ref. 5:pp 14-55].

Currently work is under way to determine the static stability derivatives and stick-fixed neutral point of the scale model of the Pioneer currently in use by the US Navy. This information will be compared to data from the computer model mentioned before and to known information of the Pioneer.

III. MODIFICATIONS

A. GENERAL INSTRUMENTATION

The instrumentation in the aircraft consisted of two systems: 1) instrumentation for the successful and safe flight of the aircraft, and 2) instrumentation for gathering data during the flight. Some of the equipment was used for both purposes.

Instrumentation required for data collection consisted of a 4000 mA_H, 4.8 VDC battery pack, control servos, airspeed indicator system, alpha-beta probe, switching circuit and a portable seven-channel recorder. These items will be described in greater detail in the following sections.

The equipment for the safe flight consisted of the 4000 mA_H, 4.8 VDC battery pack, receiver and control servos. Also required for the aircraft to fly were an engine and fuel supply. The battery pack and the servos were used by both the flight control system and the data collection system.

B. CONTROL-SURFACE DEFLECTION

Control-surface deflections were measured from the voltage output of the potentiometers inside of the control servos. Wires were added to the servos for this purpose, and ran through a switching board to a seven channel recorder located in the aircraft fuselage. A calibration of the control-surface deflection versus output voltage is shown in Figure 3.1 for the elevator, right rudder and right aileron. A consistent linear

relationship in the calibration curves can be noted. Prior to flight a field calibration (neutral and full deflections) was performed on all control surfaces. A schematic of the switching circuit is shown in Appendix B.

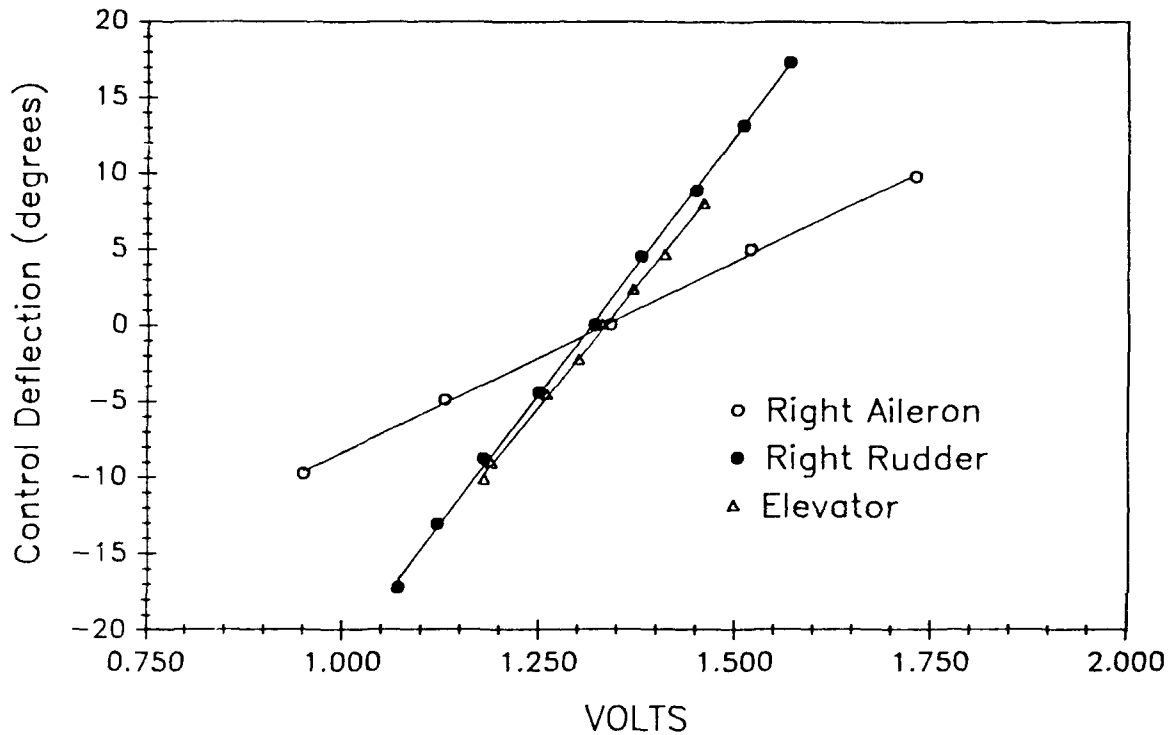

Figure 3.1 Control Deflection vs Voltage

C. AIRSPEED INDICATOR

A pitot-static probe was installed in the left wing about 1.5 chord lengths from the wingtip, extending through the leading edge 1 chord length in a boom-like configuration. Pressure tubing ran through the wing to a pressure transducer located in the fuselage. The

airspeed unit, requiring ± 15 VDC, was powered by a 4000 mAH 4.8 VDC battery through a DC-DC converter. Figure 3.2 shows a calibration curve for the airspeed transducer versus voltage output for the unit, from data taken from tests performed in the 32 by 45 inch low speed wind tunnel. An installed pitot-static calibration has not yet been performed.

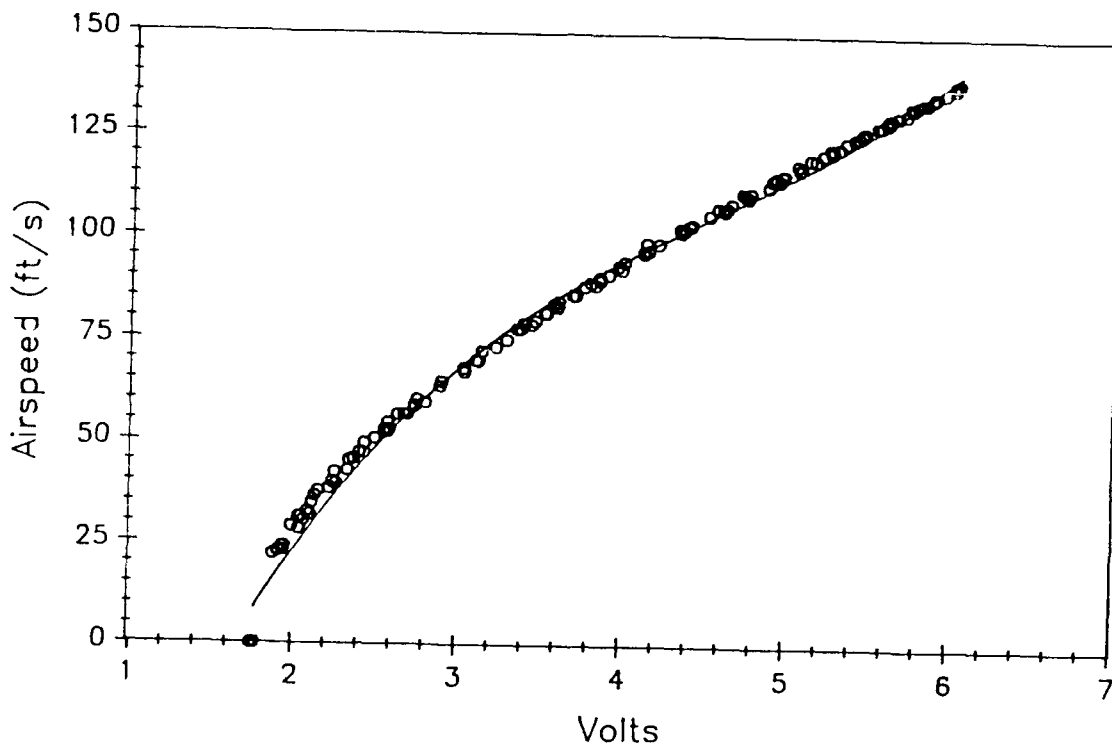

Figure 3.2 Airspeed Transducer Calibration

D. ALPHA-BETA PROBE

The alpha-beta probe is shown in Figure 3.3. A nose boom was designed and constructed to gather angle of attack (α) and sideslip (β) information. The boom

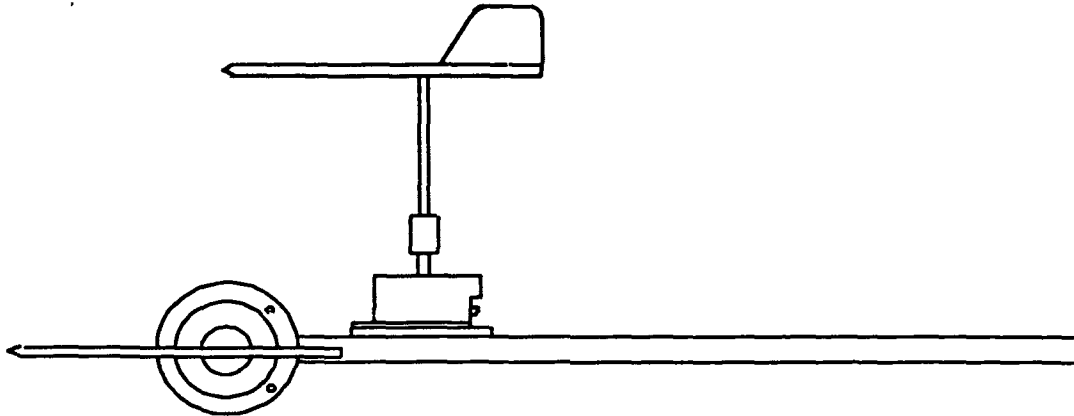

Figure 3.3 Alpha-Beta Probe

extended a chord length in front of the nose on the aircraft centerline. Two brass vanes were attached to low-torque one-turn potentiometers at the end of a 1/4-inch stainless steel tube. The boom was inserted through a hole in the fiberglass nose of the aircraft and through a wooden block attached to the first bulkhead; the assembly was held in position by a pin through the boom and a nut on the end of the boom. Figure 3.4 shows calibration plots for the alpha and beta vanes versus voltage output. The input voltage of 10 VDC came from stepping down the voltage from the DC-DC converter previously mentioned. The calibration of the vanes was performed in the field, using a alignment tool consisting of a protractor attached to a steel rod, which was temporarily attached to

the boom as a reference line. A flight calibration to include any disturbances to the flowfield at the probe from the aircraft has not yet been carried out.

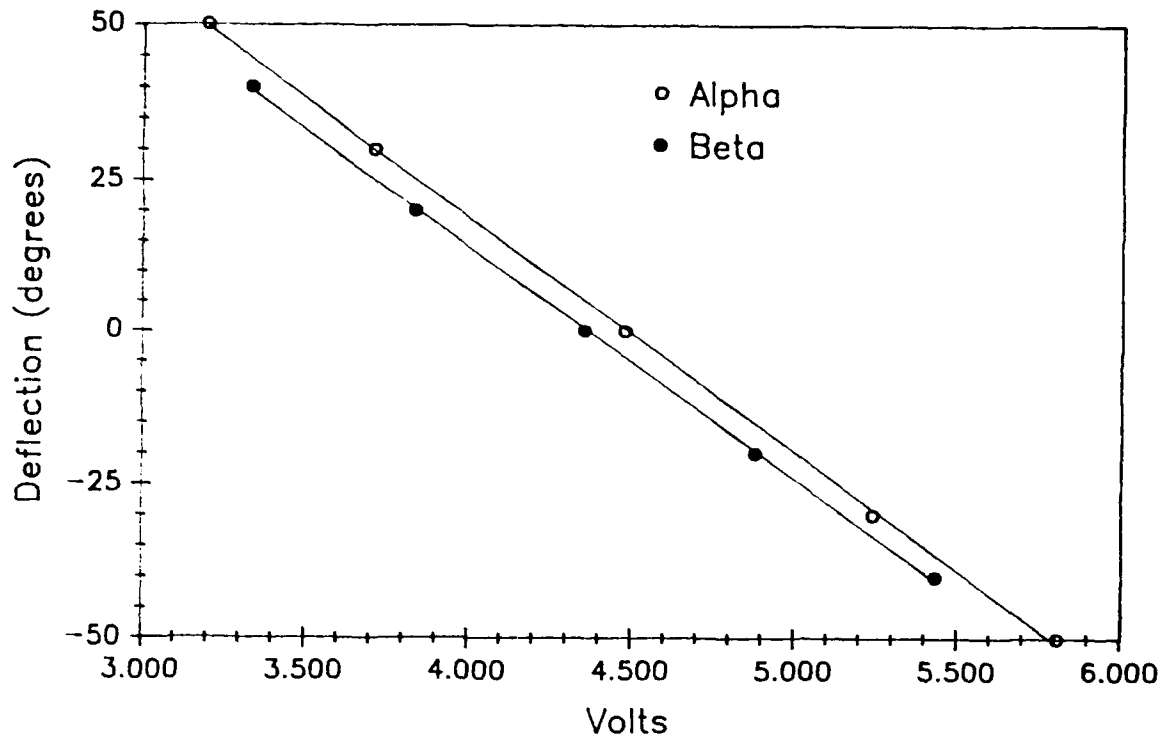

Figure 3.4 Alpha-Beta Calibration

E. POWER SUPPLY

The seven-channel recorder was powered by an internal 9 VDC battery; all other systems were powered by the 4000 mAH nickel-cadmium 4.8 VDC battery pack. The battery pack fed power to the receiver and from there to the servos, and to a DC-DC converter which supplied the ± 15 VDC required by the airspeed transducer and the 10

VDC required by the alpha-beta probe. The battery pack provided power for about 3 hours when all aircraft systems were powered. A schematic for the power distribution system is located in Appendix B.

F. RECORDING SYSTEM AND DATA PLAYBACK

Data was recorded onboard with a seven-channel analog recorder. The unit was extremely portable, being approximately 2 x 4 x 6 inches in size and weighing 1.3 pounds. A switching circuit allowed seven of the ten possible signals to be recorded at any one time.

The cassette tapes were played back through a seven-channel bench playback unit. The seven signals were digitized through a high-frequency analog to digital conversion board and processed with the use of commercially available software to be stored on the hard disk of a 286 AT personal computer.

IV. EXPERIMENTAL PROCEDURES

A. VIBRATION ANALYSIS

The flight data recorder was installed in the aircraft and held in place with rubber bands. Vibration is a continual concern for radio components in model aircraft; it was hoped that vibration effects would not be a concern. But in initial check-out flights, the data from the potentiometers registered mostly zero. It was noted that the data appeared correct until the power was advanced for take-off. At this point it was suspected that the possible high level of engine vibration was the source of the problem. Discussions with the manufacturer of the recorder determined that the instrument was certified only to 1.5-g vibration at 200 Hz, and that the device would cease to function properly at a loading of 2.0-g's. Attempts were made to isolate the recorder, and are described below.

1. ENGINE RUBBER MOUNTS

To try to reduce the vibration in the airframe, a series of rubber mounts on the engine were tried while wrapping the recorder in different foam paddings. The first set of rubber mounts were three 1/2-inch diameter mounts spaced at 120 degrees around the engine mounting plate. A ground test was then performed; the engine was run at idle, minimum flight power and high power. During each engine run-up sequence the recorder was packaged in three different configurations. The first was to place the recorder in a neoprene rubber sleeve and fasten it to the interior of the fuselage with rubber bands. The second was to wrap the recorder and neoprene sleeve in 1.5-inch thick foam padding

and place the recorder in the fuselage. The last configuration was to place the recorder on its side in the neoprene sleeve inside the fuselage. The last method attempted to check the dependence of orientation of the recorder on the recording accuracy. The same series of tests were then run again using 3/4-inch diameter rubber mounts.

Reference voltages were recorded prior to starting the engine. Unusable data were noted when zeros would appear on the output; the lowest actual voltage should have been about 0.9 VDC. Of the three engine mounting methods, the one with the 3/4-inch diameter rubber mounts was the most successful. Use of the 3/4-inch mounts gave the most consistent data over the speed range of the engine and had the smallest number of readily identifiable data points in error. Of the three recorder packaging methods the one that appeared to be the best was the neoprene sleeve fastened to the fuselage with rubber bands. Placing the recorder on its side was by far the worst method for obtaining a consistent recording.

2. FUSELAGE ACCELEROMETER TEST

The next step was to attach an accelerometer to the aircraft fuselage where the recorder was usually attached. A piezoelectric accelerometer was used in the aircraft. The information from the accelerometer was fed into a spectrum analyzer, an oscilloscope and a frequency counter. The data for peak g-loading from the accelerometer placed in the fuselage is shown below in Table 4.1. The test with the accelerometer was conducted at three different power settings, corresponding to the rpm shown in Table 4.1. The power settings during the ground tests were idle, minimum flight power and full power. Figure 4.1 is a plot of peak g-loading on the airframe at the different rpm's of the engine.

TABLE 4.1 G-LOADING

RPM	Freq Hz	Peak g-Loads
2500	134	5
4700	134, 200	7.5
7800	135, 240 450, 790	30.0

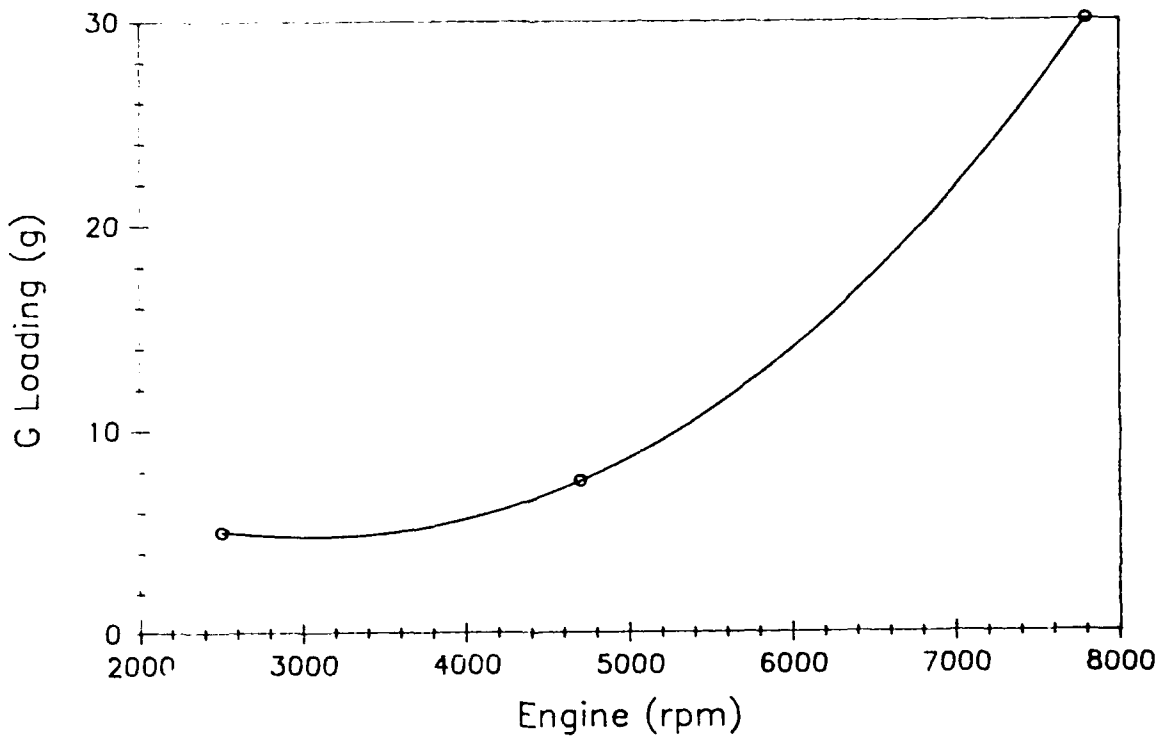

Figure 4.1 Peak g-Loading of Recorder

By comparing the vibration data of the airframe to the specifications for the recorder, furnished by the manufacturer, it was obvious that the major contributor to the problem, if not the entire problem, was the vibration being introduced into the aircraft. It should be noted from Table 4.1 that a frequency of approximately 134 Hz is present at each power setting. It is believed that the 134 Hz corresponds to the first harmonic being introduced by the propeller. It is also the predominate frequency at each power setting as evidenced by the trace on the spectrum analyzer; it was the only frequency shown by the frequency counter. Other frequencies found during the test were approximate harmonics of the 134 Hz frequency. Therefore any attempt to isolate the recorder from the vibration should be primarily concerned with the attenuation of the 134 Hz frequency.

3. SHAKER TEST OF FUSELAGE MOCKUP

A mock-up of the center section of the fuselage, the area where the recorder was mounted, was designed and built so that a vibration isolation system could be tested prior to installation and testing in the aircraft. This had to be done because the engine installation on the aircraft does not allow for efficient cooling of the engine. The continuous running of the engine during ground vibration tests could then lead to the overheating and failure of the engine. The mock-up of the fuselage was then mounted on a shaker table to simulate the vibration of the aircraft. It should be noted that the shaker table can only simulate a single frequency at a time. A picture of the fuselage frame mock-up mounted to the shaker table is shown in Figure 4.2. The recorder was modeled by a wood and metal block that had the same dimensions and weight as the actual recorder. This was done so as not to expose the recorder to the magnetic field of

the shaker table. This block was then placed in the neoprene sleeve used by the recorder in the aircraft and suspended in the frame of the fuselage. The harness in which the recorder hung was constructed from nylon cord, with the dampening supplied by 1/4-inch diameter surgical tubing strung in a eight-point suspension arrangement. The dampeners

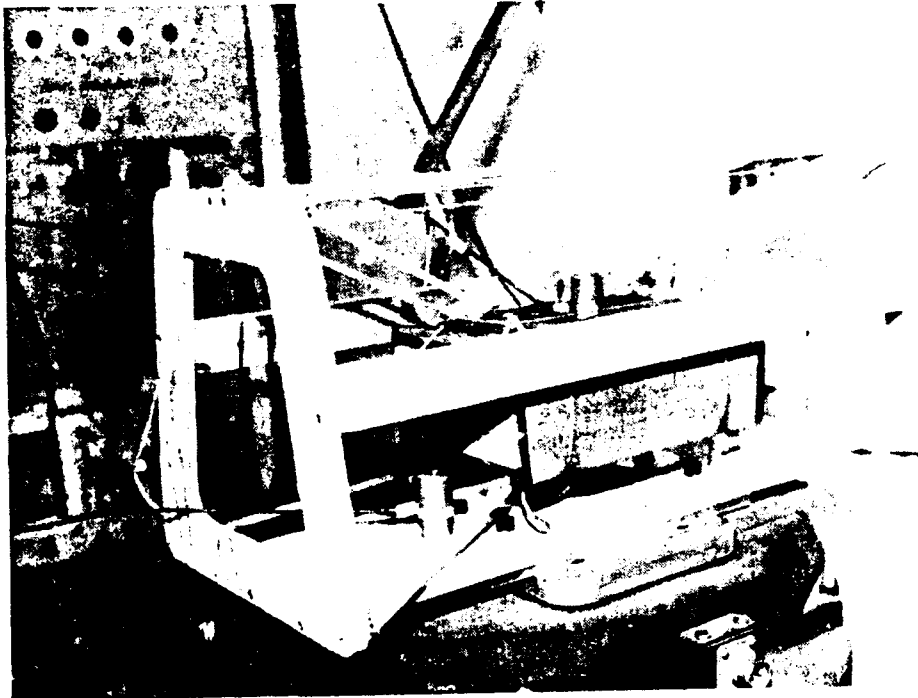

Figure 4.2 Shaker Test Stand

were fastened between the corners of the recorder and the fuselage frame. The extra cord seen in the picture was used to adjust the length of the dampeners to find the most efficient length for use in vibration isolation.

Two accelerometers were used in this test. The first was attached to the frame that was fastened to the shaker table. The second accelerometer was fastened to the block of wood and metal that acted as the recorder during the test on the shaker table. The arrangement of the accelerometers is shown in Figure 4.2. The output from the accelerometers were fed into an oscilloscope where the peak g-loading could be measured. The frequency of vibration was measured by a frequency counter that was connected to the signal generator.

Table 4.2 shows the information from the shaker test after the lengths of the dampeners were chosen. As the tests were run on the shaker table, the g-loading and frequency closest to those observed in the ground test of the aircraft were the values used. This was done as a method of further simulating the g-loading being experienced by the aircraft.

TABLE 4.2 SHAKER TEST RESULTS

Freq Hz	g-Loading Frame	g-Loading Recorder
70	3.75	.035
132	7.5	.075
136	7.5	.050
296	12.5	.025
298	12.5	.020
438	20.0	.035
439	20.0	.025
595	20.0	.020
596	20.0	.025
797	30.0	.017
799	30.0	.020

As can be seen by the figures in Table 4.2 the suspension system was better tuned for higher frequencies than for lower frequencies. The performance at the lower frequencies was still well within the tolerances of the recorder.

4. TEST OF SUSPENSION SYSTEM IN THE AIRCRAFT

The recorder suspension rig was then placed in the aircraft for a ground run up test. The suspension system had to be modified slightly in the way that the lines were attached in order that the setup could be fastened in the aircraft. This modification was due to the aircraft not having the open space around the bulkheads like the frame mock-up. An accelerometer was connected to the mock-up of the data recorder in the suspension rig for the test to measure the loading on the recorder. The ground test was run as before at three different power settings: idle, minimum flight power and full power.

The differences between the shaker test model and the actual aircraft should be noted. First, the shaker model did not have wings, tail assembly or landing gear. Second, the actual aircraft was not bolted down and was experiencing some dampening effect in that it must be held in place. The most important feature was that the aircraft did not vibrate at a single frequency. The aircraft vibrated at several frequencies at the same time with the predominate frequency being approximately 134 Hz at all power settings. This is also the frequency at which the suspension rig had its poorest performance.

The results of the test are presented in Figure 4.3. The upper line indicates

the results from the test without the recorder suspended between the vibration dampeners. The lower line shows the results when the vibration dampeners were installed in the aircraft. From the two curves it can be seen that the vibration that the recorder was

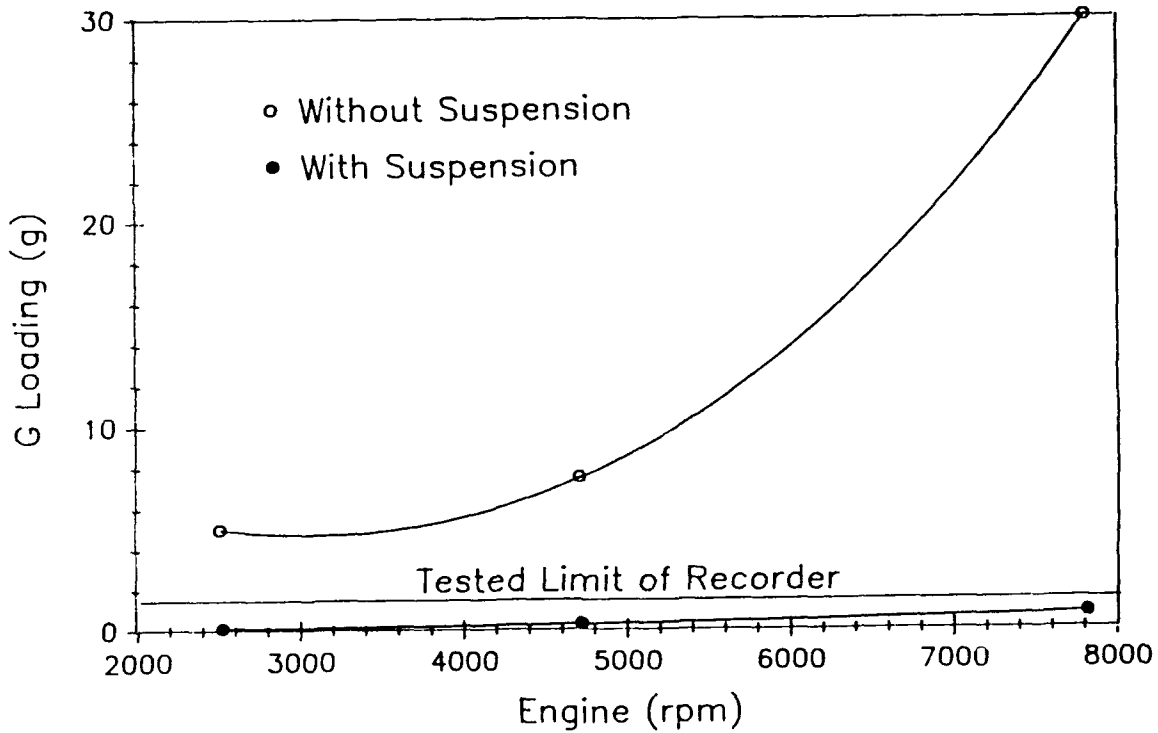

Figure 4.3 Peak g-Loading Recorder

experiencing had been reduced significantly. The maximum loading that the recorder was experiencing was a peak 0.75 g's at full power. This was well within the design capabilities of the recorder.

The g-loading being experienced by the recorder in the aircraft was much higher than the g-loading model the recorder on the shaker table experienced. This increase was attributed to the way that the aircraft responds to the power setting of the engine. At all power settings the low frequency vibration is predominate; this could not be easily modeled on the shaker table.

5. ELECTRICAL CONNECTIONS

The last area on which the vibration had a significant effect was the electrical connections. Several solder connections in the data acquisition system were broken and had to be replaced. Problems were also encountered in the pressure fit connectors; some were replaced. Vibration is also believed to be primarily responsible for the failure of a flight control receiver. These problems manifested themselves in the fact that they were only apparent or repeatable when the aircraft was at full power.

B. FLIGHT TESTING

Two different types of flight test were conducted: steady sideslips for lateral-directional static stability data and tests with changing center of gravity for longitudinal static stability parameters.

1. STEADY SIDESLIPS

The steady sideslip flight tests were conducted in order to determine the $d\delta/d\beta$ and $d\delta/d\dot{\beta}$ for the aircraft. These derivatives give an indication of the lateral-directional stability and control of the aircraft. To perform the test the aircraft instrumentation described previously and the recorder were installed to record the data during the flights.

The pieces of information that were recorded were angle of attack, sideslip angle, right rudder deflection, right aileron deflection, elevator deflection and indicated airspeed.

The flight tests were flown in the following manner. After take off, a downwind turn was commenced to set the aircraft up for the first pass. On the first pass the aircraft was allowed to drift with the prevailing wind. During the second pass the aircraft was put into a constant sideslip either to the right or the left and flown in that configuration until a downwind turn was made. Each pass was a nominal 20 seconds in length. The next pass would be with a larger sideslip angle in the same direction as during the second pass. During the pass the altitude was held as constant as possible. There was no altitude instrumentation; therefore the pilot maintained a constant altitude by observing the aircraft in flight. This procedure would then be repeated for sideslips in the opposite direction. The flight test pattern would be repeated as many times as possible while the fuel supply lasted, with a five minute reserve. This approach would allow for about twelve minutes of flight time during which data could be gathered, or about nine data runs.

2. CENTER OF GRAVITY CHANGES

The next series of flight tests were carried out with a change in the center of gravity. Changing the c.g. allows the determination of the neutral point, as well as elevator control power, lift curve slope and longitudinal static stability of the aircraft. During the test the information that was recorded was angle of attack, sideslip angle, elevator deflection, right rudder deflection and airspeed.

The flights were flown in the same race track pattern as were the steady sideslip tests. The differences were that no sideslips were performed and that data were taken on both legs of the pattern with the airspeed being changed after each racetrack pattern. The information of interest was change in angle of attack with change in airspeed, and the elevator deflection required to hold the aircraft in steady level flight. This procedure was carried out for nominal center of gravity locations of 30%, 33% and 36% of the wing mean aerodynamic chord. The center of gravity position was changed by either adding or subtracting weight in the nose of the aircraft.

C. DATA REDUCTION EQUIPMENT

As stated earlier the recording unit was a portable analog seven-channel recorder. The recording amplifiers in the recorder were set to the 10-volt scale. The 1-volt scale could not be used since all the data lines had at least a 1.8-volt output. The data were recorded while the aircraft was in flight and a voice recording as well as a manually-recorded paper record were kept during the flight.

After the flight, the data tape was played back through a bench playback unit. The unit had an output for each channel and an additional output so that any individual channel can be monitored during the playback. Each channel was routed to an analog to digital conversion board located in a 286 AT personal computer.

Commercial software was used to access the analog to digital signals board. The software was set up to process the seven channels of data and to add an eighth channel

that contained the time in seconds. This method allowed for correlation of the digitized data to the recorded time history of the flight.

1. CALIBRATION OF THE PLAYBACK SYSTEM

The playback system was calibrated by recording voltages known to the fourth decimal place on the portable recorder. These voltages were then played back through the playback unit and the voltages were read to the fourth decimal place using a digital multi-meter. Since the bench unit was limited to a maximum playback voltage of 2 volts, the system was scaled so that 5 volts played back as 1 volt. This setup completed the calibration of the recorders.

The A/D board was calibrated using a program furnished by the manufacturer, a voltage supply and a digital multi-meter with a readout of voltage to the fifth decimal place.

The entire system was then run to check the accuracy of the system against a known recorded voltage. The voltage supplied was known to the fourth decimal place. The portable recorder was used to record the voltage. The output was then played back through the bench playback unit. The A/D board and the 286 AT were used to reduce the data. The mean playback voltages and standard deviations are listed in Table 4.3. The actual recorded voltage was 4.9997 VDC.

TABLE 4.3 PLAYBACK VOLTAGE

Channel	Mean Voltage	Std Deviation
1	5.000	0.145
2	4.970	0.135
3	4.960	0.150
4	5.005	0.155
5	4.955	0.125
6	4.995	0.170
7	4.970	0.170

V. FLIGHT TEST RESULTS

A. STEADY SIDESLIP TESTS

The first series of flight tests flown were steady sideslips. These tests were to determine the trend of the lateral-directional behavior of the aircraft. After the first test flight the aircraft experienced electromagnetic interference of the flight controls. The remaining flights for the day were canceled to investigate the cause of the interference.

During the test flight nine different steady state sideslips were flown. The data were sampled at 2 Hz from these flights and were plotted in Figure 5.1 to determine $d\delta_r/d\beta$ and in Figure 5.2 to determine $d\delta_r/d\beta$. Inspection of Figures 5.1 and 5.2 reveals a lot of scatter. At this point an investigation of why there was so much scatter was initiated. The first step in the investigation was to plot the outputs from the right rudder, right aileron and sideslip vane versus time at the 2 Hz sampling rate. A sample plot of the 2 Hz time traces can be seen in Appendix A. There were no trends noted at this frequency; therefore the sampling rate was increased. Sampling rates of 500 Hz, 2500 Hz and 5000 Hz were used. At the sampling rate of 5000 Hz a frequency of approximately 500 Hz was apparent. A sample plot of the data sampled at 5000 Hz is located in Appendix A. The 500 Hz signal is believed to be the third harmonic of the propeller frequency.

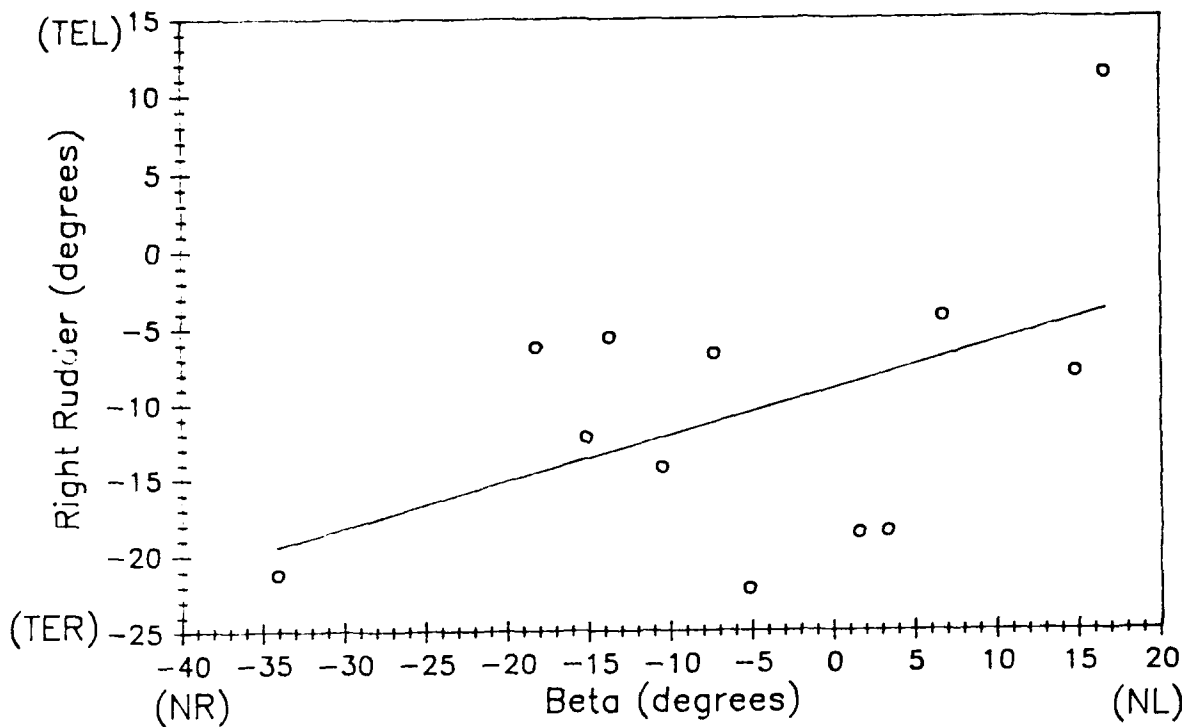

Figure 5.1 Right Rudder vs Beta, 2 Hz Sampling

The frequency that was discovered in the data was believed to be due to the propeller harmonic propagating through the airframe. The suspension system, though attenuating the g-loading well, is allowing the higher frequencies to be transmitted to the recorder. The recorder has only been previously tested to 200 Hz by the manufacturer. To compensate for the dominant frequency of 500 Hz the data was sampled at 5000 Hz for a time span of 0.02 seconds and the values were averaged to obtain a mean. This was

done for the right rudder, right aileron and beta vane. The data for these points is located in Table A.1 in Appendix A.

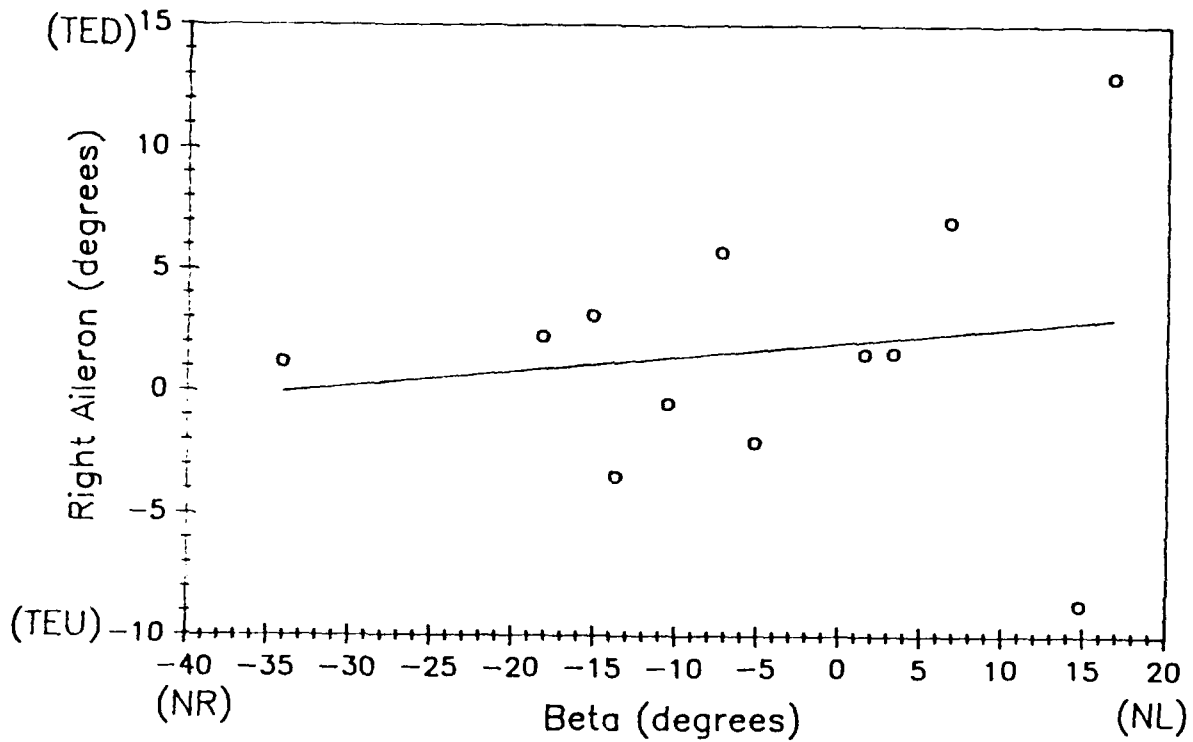

Figure 5.2 Right Aileron vs Beta, 2 Hz Sampling

Rudder deflection was plotted against beta in Figure 5.3 for the filtered data. From the plot it can be seen that the aircraft is reacting in a stable fashion. That is, to produce a left sideslip, left rudder was required. The second line represents points calculated from information supplied by the manufacturer of the full scale Pioneer. These points were calculated by using stability and control derivatives furnished by the manufacturer,

assigning arbitrary bank angles and calculating the required control deflections and sideslip angles. The equations used to calculate the control surface deflections are listed

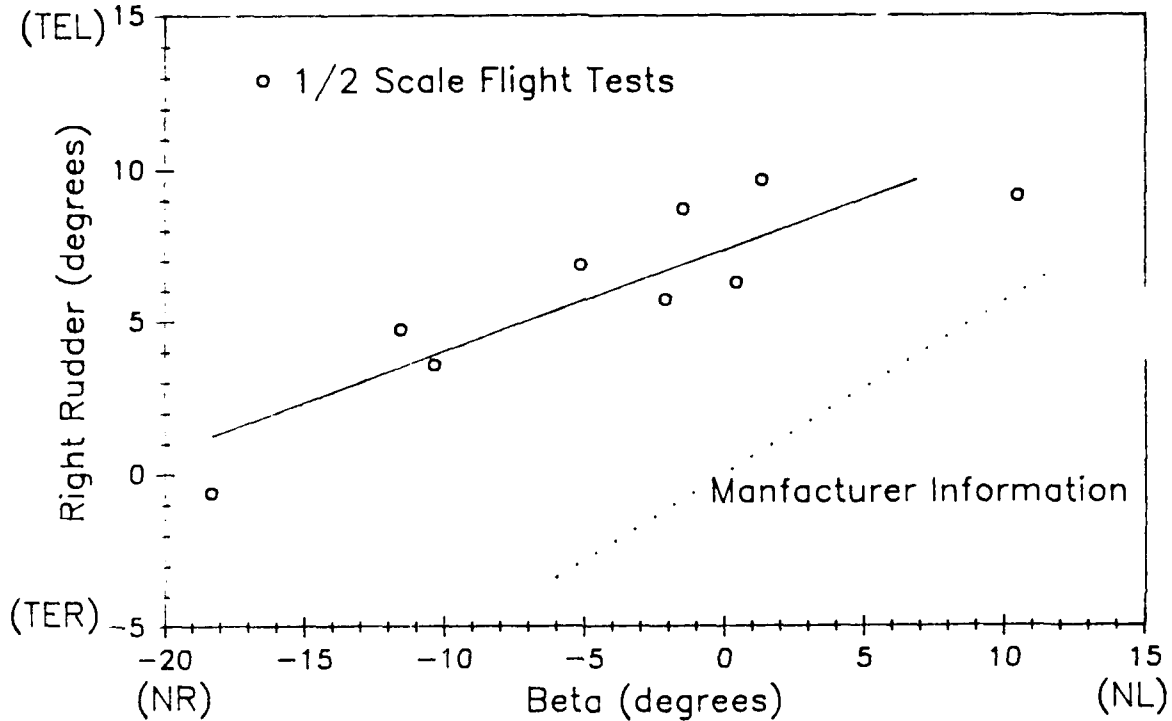

Figure 5.3 Right Rudder Deflection vs Beta

in Appendix A. Both lines show the same tendency of the aircraft, but the line for the 1/2-scale is offset from the information for the full scale. The slopes of the two lines are similar though, being 0.334 for the 1/2-scale and 0.523 for the full scale vehicle.

Aileron deflection was plotted versus sideslip angle in Figure 5.4. This plot also shows that the aircraft is responding in a stable fashion in the lateral mode. To maintain

a steady course, aileron deflection must be increased as sideslip angle increases. The second curve in Figure 5.4 once again represents the points calculated from data supplied

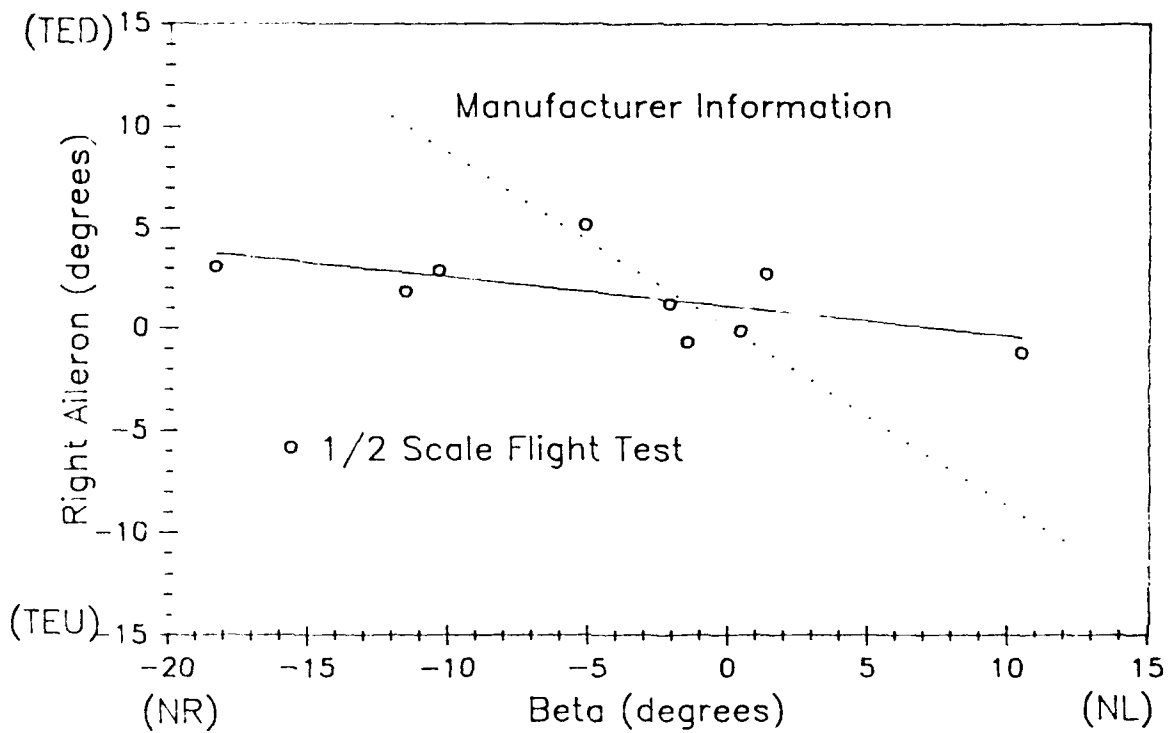

Figure 5.4 Aileron Deflection vs Beta

by the manufacturer of the full scale Pioneer. In this case there were also differences between the flight test results and the data extracted from the manufacturer's information. Both the 1/2-scale flight test and the manufacturer's full scale information cross at approximately the zero-zero point on the graph. The slopes of the two lines are different, the slopes for the 1/2-scale and the full scale being -0.136 and -0.570 respectively.

From the information supplied by the manufacturer the sideslip limitations were calculated. These values were determined using a linear scheme and therefore do not take into consideration nonlinear effects, such as rudder lock. The values for sideslip angle that correspond to maximum aileron deflections are listed in Table 5.1.

TABLE 5.1 MAXIMUM SIDESLIP

Aileron (deg)	Rudder (deg)	Sideslip (deg)
-20	12.9	23.0
20	-12.9	-23.0

From the table it can be seen that the aileron deflection is the limiting factor for maintaining the maximum sideslip angle. Rudder limits have not yet been reached.

B. CHANGING C.G. TESTS

The second series of tests was performed changing the c.g. location of the aircraft. A series of different airspeeds was flown to obtain elevator deflection as a function of aircraft c.g. and true airspeed. The data was first sampled at 2 Hz. The time trace history at this frequency indicated excessive scatter as in the steady sideslip tests. The sampling rate was increased to 5000 Hz where the 500 Hz frequency could be seen in the data. The time trace histories for the 2 Hz and 5000 Hz samplings are located in Appendix A. The data was then averaged over a .02 second interval and the mean values for different c.g. locations were plotted in Figure 5.5.

The information shown is widely scattered and no conclusions can be drawn from the plots as to what $d\delta/dC_L$ was for the different c.g. locations. The scatter was believed

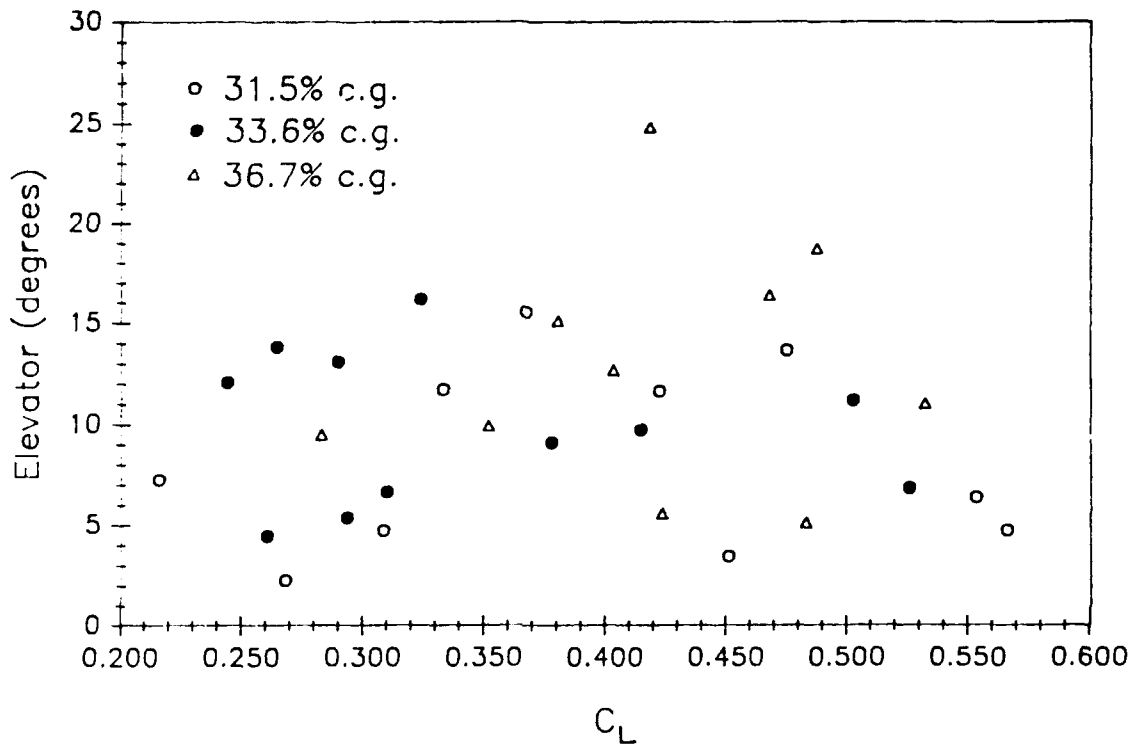

Figure 5.5 Elevator Deflection vs C_L

to be due to the vibration affecting the quality of the data recording. The data plotted in Figure 5.5 is listed in Appendix A.

C. GROUND TEST

Due to the scatter observed in the time trace histories described earlier a ground test of the system was performed. The recorder was installed in the aircraft with an oscilloscope attached to the recorder inputs. This allowed the signal that was being recorded during the changing rpm of the engine to be viewed. There was no 500 Hz signal present at the recorder inputs.

The data tape was then played back through the bench unit with the oscilloscope and a frequency counter attached to the output from the unit. The high-amplitude 500 Hz signal was very evident, especially when the rpm of the engine went beyond the mid power range of the engine. This would indicate that even with the g-loading of the recorder within limits, the frequency of the vibration had a significant effect on the recorder at the higher engine rpms.

VI. RECOMMENDATIONS

There are a few recommendations that should be put forth at this time for continued work in developmental flight testing of 1/2-scale vehicles. The following will discuss the recommendations that are oriented towards data acquisition and safety of flight.

The first recommendation is the use of a telemetry system for data acquisition. The use of an onboard recorder did not work satisfactorily for the flight tests. This is primarily due to the high-frequency g-loading that a powered scale vehicle experiences because of vibration. Even though a suspension system was designed to reduce the g-loading of the recorder, the frequency of the vibration still appeared to have a large effect on the performance of the recorder. This was more pronounced during these test flights than in earlier tests (see Ref. 9) because of the closer tolerances that must be maintained on a seven channel system vice a one channel system. The use of telemetry would eliminate the effects that vibration has on electromechanical recording devices. Telemetry would also decrease the space and the weight of the data collection system.

The second recommendation is not to use the control servos for determination of control surface deflection. Though this worked well during the tests and gave consistent results, there is a danger of losing the aircraft if one of the connections should fail. Instead, a separate potentiometer should be used that is not electrically connected to the control servo. This would accomplish three goals: 1) reduce the probability that the

aircraft could be lost due to feedback from the data collection system, 2) allow the tailoring of electrical outputs by the use of moment arms and gearing, and 3) provide a common reference voltage for use in a telemetry system. Currently each servo has a slightly different reference voltage and range.

The third recommendation is that more testing needs to be done. Use of a radio controlled aircraft for gathering meaningful flight test data has been shown to be successful. There was not enough data gathered to make hard conclusions about the possible performance of the airframe. The testing should concentrate on those areas where a comparison can be made with the information received from the manufacturer of the full scale Pioneer and from planned 40%-scale wind tunnel testing. In this sense the lateral-directional and longitudinal characteristics are excellent starting points.

APPENDIX A: DATA

Figures A.1 through A.4 are the sample time trace histories at 2 Hz and 5000 Hz for the the steady sideslip case and the changing center of gravity flight tests.

Table A.1 contains the data plotted for the aileron deflection vs beta and the rudder deflection vs beta.

Tables A.2 through A.3 contain the data for the c.g. locations of 31.5, 33.6 and 36.7% of mean aerodynamic chord.

The following pages contain the equations used to estimate full scale Pioneer behavior and the values that were used in the equations.

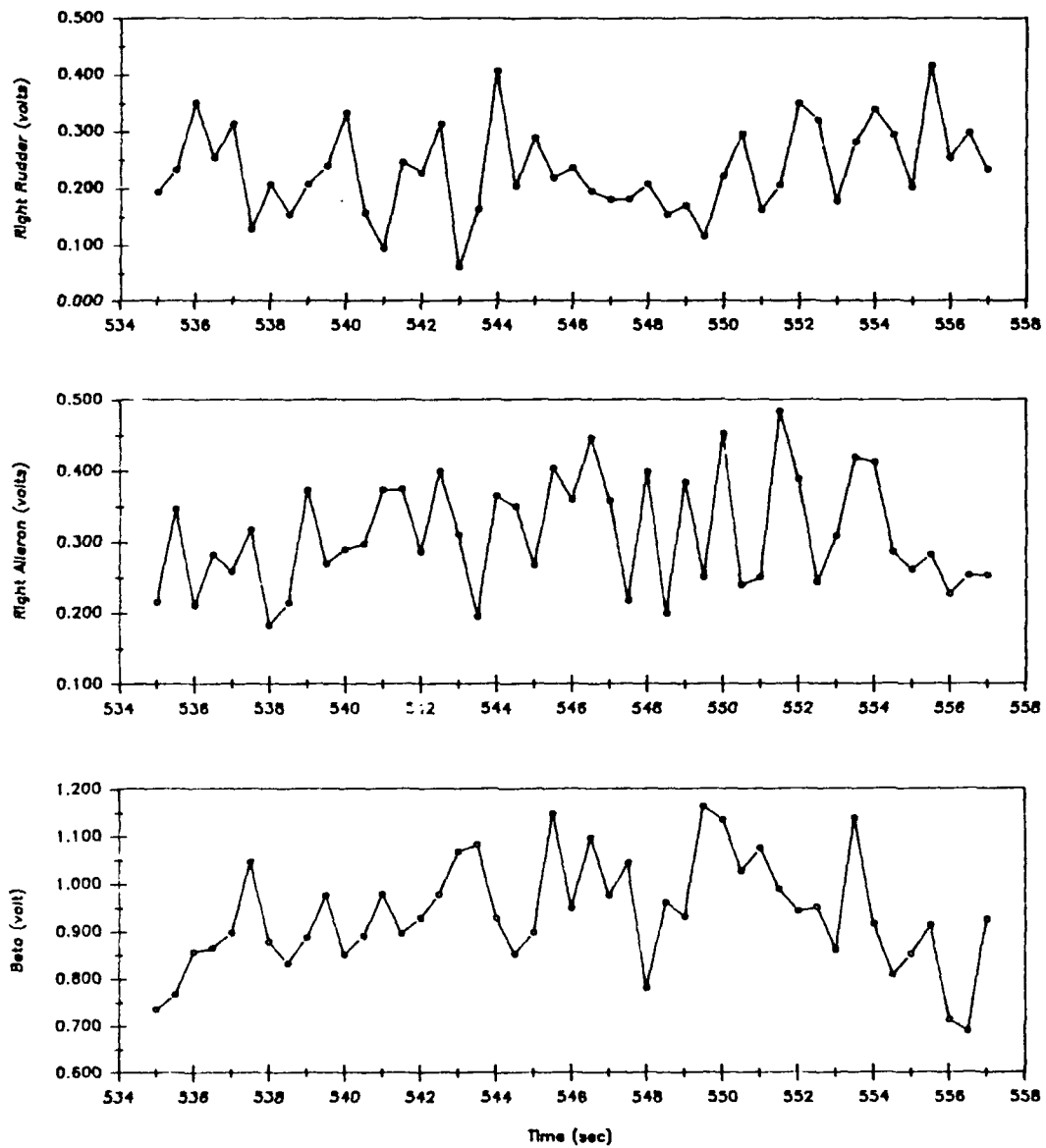

Figure A.1 Steady Sideslip, 2 Hz Time Trace

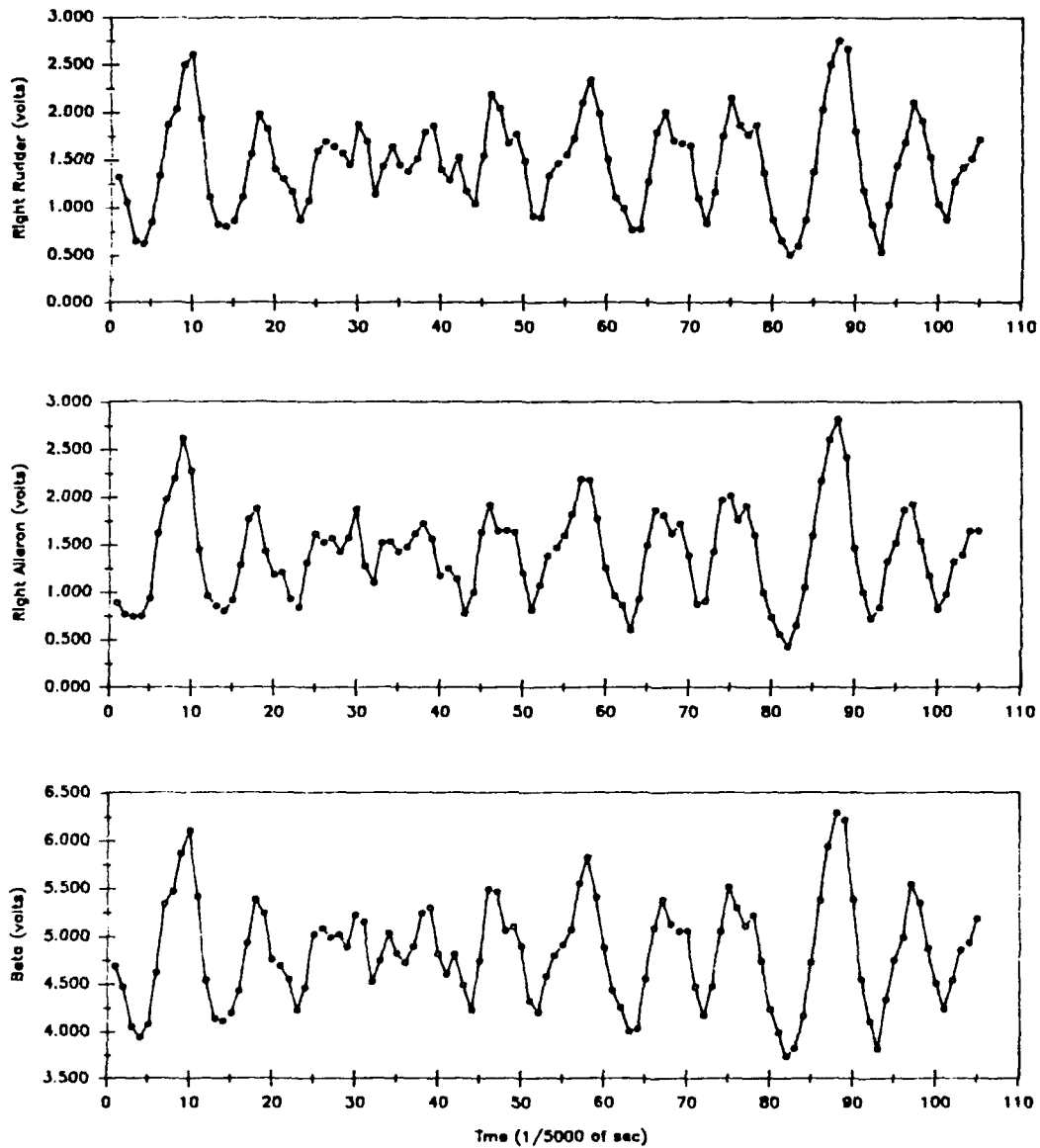

Figure A.2 Steady Sideslip, 5000 Hz Time Trace

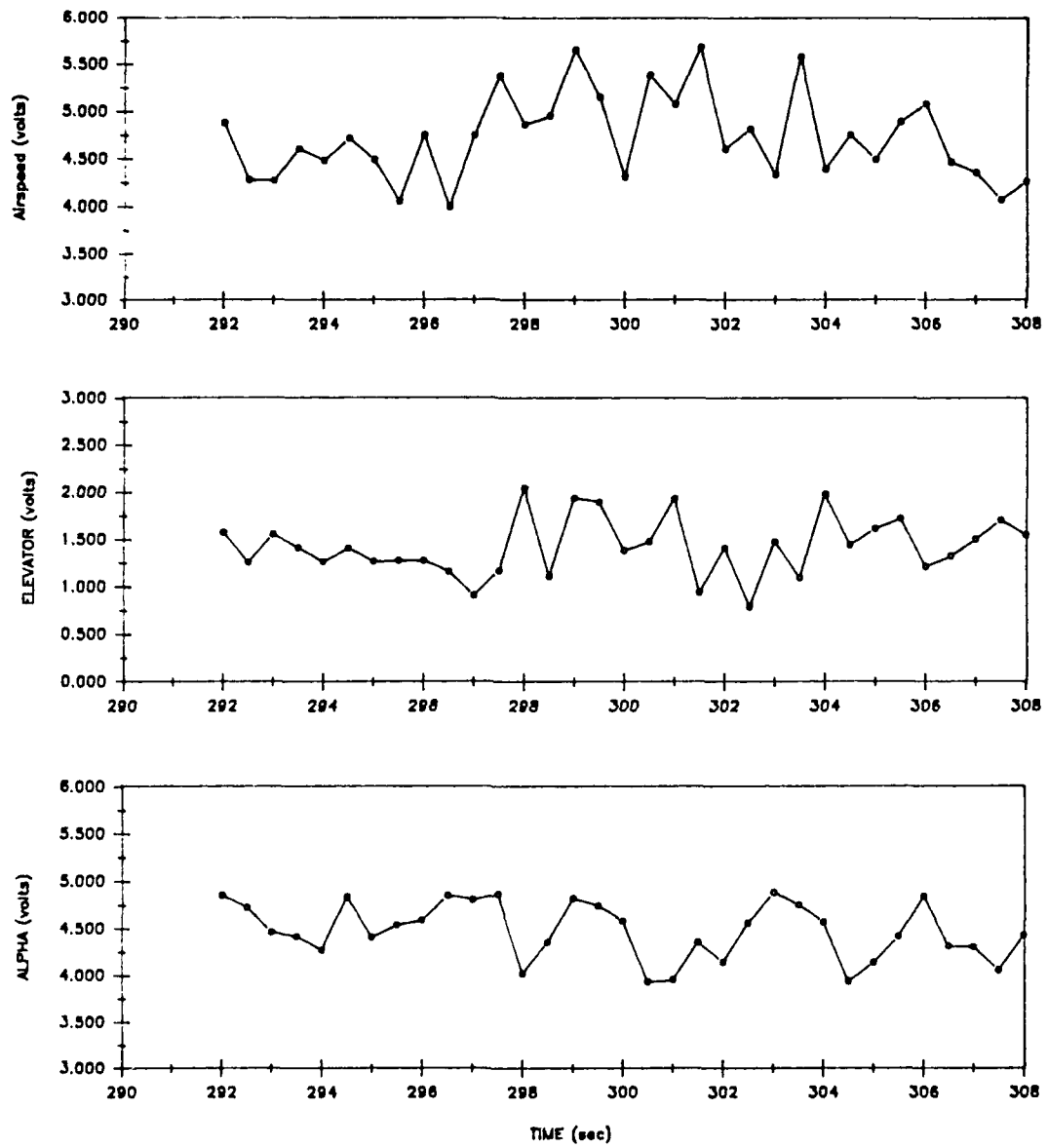

Figure A.3 C.G., 2 Hz Time Trace

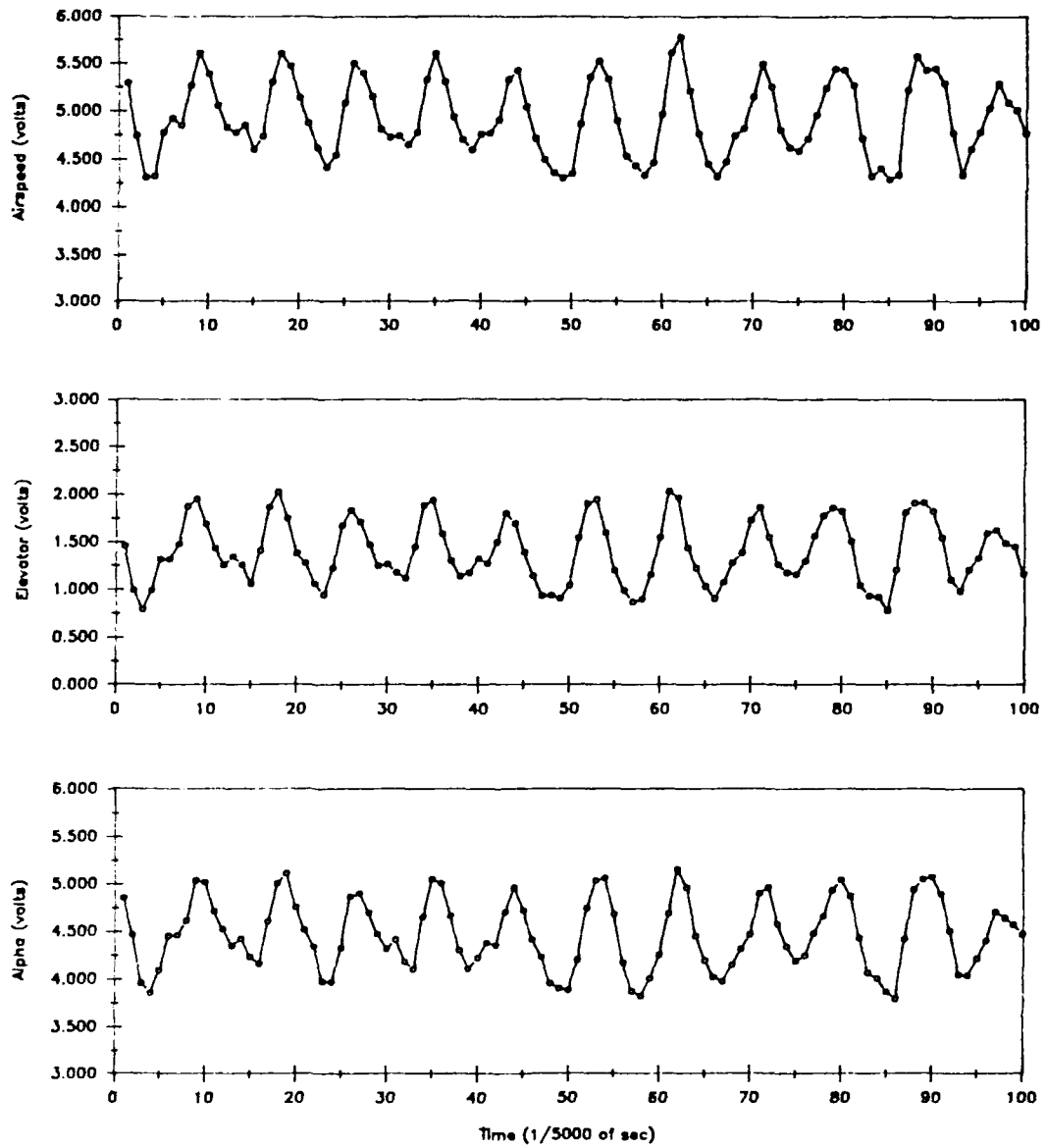

Figure A.4 C.G., 5000 Hz Time Trace

TABLE A.1 STEADY SIDESLIP

Rudder (deg)	Aileron (deg)	Beta (deg)
5.68	1.23	-2.14
6.82	5.18	-5.15
3.55	2.89	-10.37
6.25	-0.12	0.41
9.11	-1.19	10.47
4.71	1.83	-11.55
-0.62	3.07	-18.34
8.70	-0.67	-1.48
9.64	2.74	1.32

TABLE A.2 C.G. OF 31.5%

Elevator (deg)	Alpha (deg)	C_L
2.27	6.43	0.26
7.26	3.74	0.21
15.51	4.59	0.36
4.72	6.77	0.30
13.61	6.80	0.47
11.70	7.54	0.33
11.61	5.92	0.42
3.44	4.52	0.45
4.72	9.38	0.56
6.35	7.83	0.55

TABLE A.3 C.G. OF 33.6%

Elevator (deg)	Alpha (deg)	C_L
12.06	-0.34	0.24
9.71	5.84	0.41
9.07	5.29	0.37
13.06	5.66	0.28
13.79	3.85	0.26
16.15	2.42	0.32
4.44	5.73	0.26
5.35	5.25	0.29
6.62	5.92	0.30
11.16	3.45	0.50
6.80	6.21	0.52
12.25	0.13	0.60

TABLE A.4 C.G. OF 36.7%

Elevator (deg)	Alpha (deg)	C_L
24.77	3.26	0.41
12.61	2.64	0.40
9.43	5.11	0.28
9.89	4.85	0.35
15.06	4.33	0.38
5.53	5.66	0.42
18.69	7.10	0.48
5.08	9.27	0.48
10.98	4.89	0.53
16.33	4.22	0.46

The static equilibrium equations used to predict the behavior of the full scale

Pioneer are:

$$-C_L \sin \phi = C_{Y\beta} \beta + C_{Y\delta_r} \delta_r + C_{Y\delta_a} \delta_a$$

$$0 = C_{M\beta} \beta + C_{M\delta_r} \delta_r + C_{M\delta_a} \delta_a$$

$$0 = C_{I\beta} \beta + C_{I\delta_r} \delta_r + C_{I\delta_a} \delta_a$$

The values supplied by the manufacturer were:

$$C_L \quad .575$$

$$C_{Y\beta} \quad -.53 \quad 1/\text{rad}$$

$$C_{N\beta} \quad .06 \quad 1/\text{rad}$$

$$C_{N\delta_r} \quad .091 \quad 1/\text{rad}$$

$$C_{N\delta_a} \quad .0095 \quad 1/\text{rad}$$

$$C_{I\beta} \quad -.052 \quad 1/\text{rad}$$

$$C_{I\delta_r} \quad .012 \quad 1/\text{rad}$$

$$C_{I\delta_a} \quad -.012 \quad 1/\text{rad}$$

The following values were estimated:

$$C_{Y\delta_r} \quad .1 \quad 1/\text{rad}$$

$$C_{Y\delta_a} \quad 0$$

APPENDIX B: SCHEMATICS

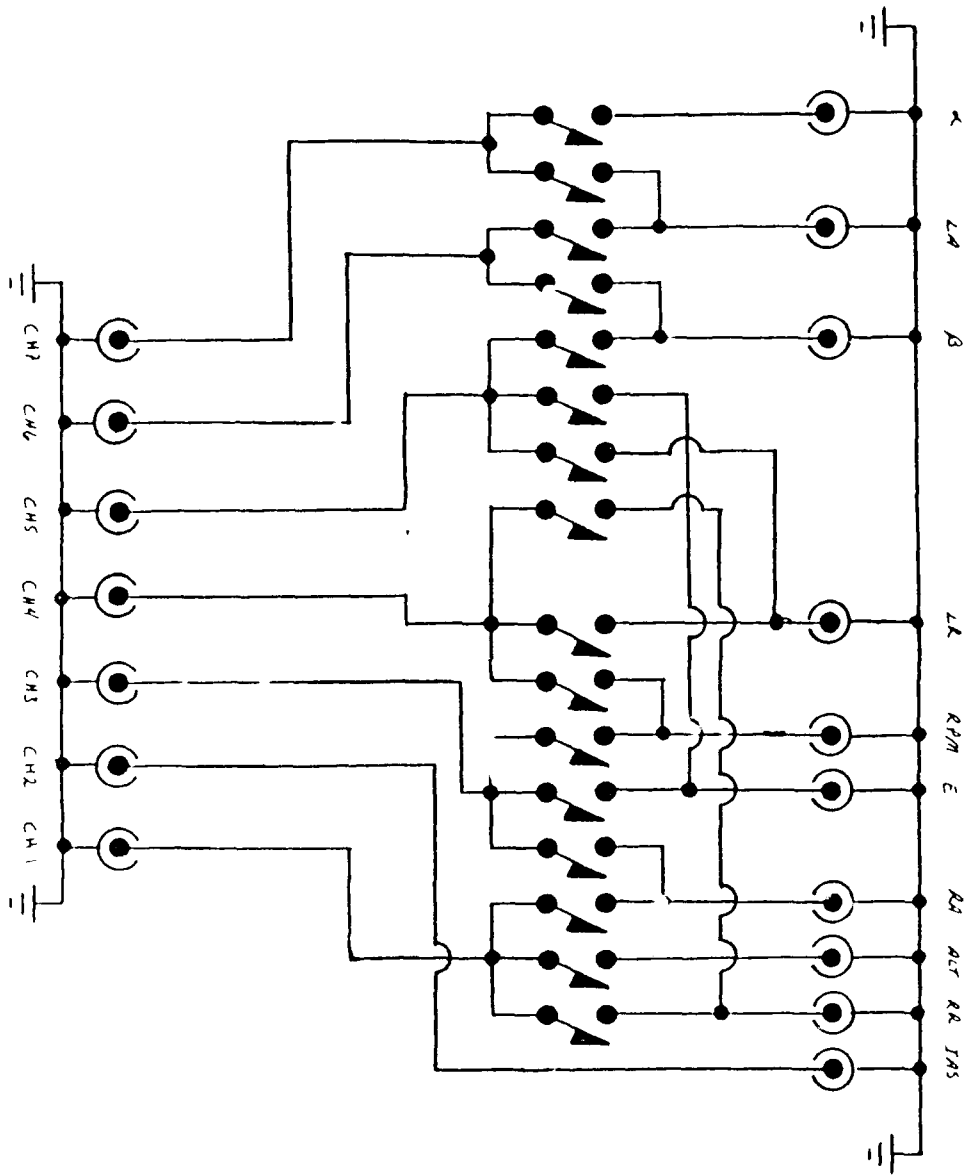

Figure B.1 Switching Diagram

The color code for the wires leaving the switching board and going to the recorder are as listed in Table B.1.

TABLE B.1 CHANNEL COLOR CODE

Channel	Color
1	Orange
2	Yellow
3	Green
4	Blue
5	Purple
6	Grey
7	White
GND	Black

Table B.2 lists which pin on the feedback wiring main connector connects to which servo or potentiometer for data collection.

TABLE B.2 FEEDBACK CONNECTOR

Pin	Line
1-3	Blank
4	+ Elevator
5	- Lt Rudder
6	+ Lt Aileron
7	+ Rt Rudder
8	+ Rt Aileron
9-11	Blank
12	+ Lt Rudder
13	- Lt Aileron
14	- Rt Rudder
15	- Rt Aileron

Table B.3 is the listing of which section of the ribbon wire is used to deliver voltage to which servo. The red, white and black notation at the servo lead (or at the receiver end) is referenced to the Futaba standard for radio-control systems. Black is ground, red is positive and white is common. The cable was connected as shown below so as to require a minimum of separation of the cable into individual strands.

TABLE B.3 SERVO WIRING

Servo	Futaba Std.	Ribbon wire
Rt Aileron	White	Yellow
	Black	Orange
	Red	Red
Lt Aileron	Red	Brown
	Black	Blue
	White	White
Rt Flap	White	Grey
	Red	Purple
	Black	Blue
Lt Flap	Black	Green
	White	Yellow
	Red	Orange
Rt Rudder	Red	Red
	White	Brown
	Black	Black
Lt Rudder	White	White
	Black	Grey
	Red	Purple
Elevator	Black	Blue
	Red	Green
	White	Yellow

Throttle is not on ribbon cable and conforms to Futaba standard

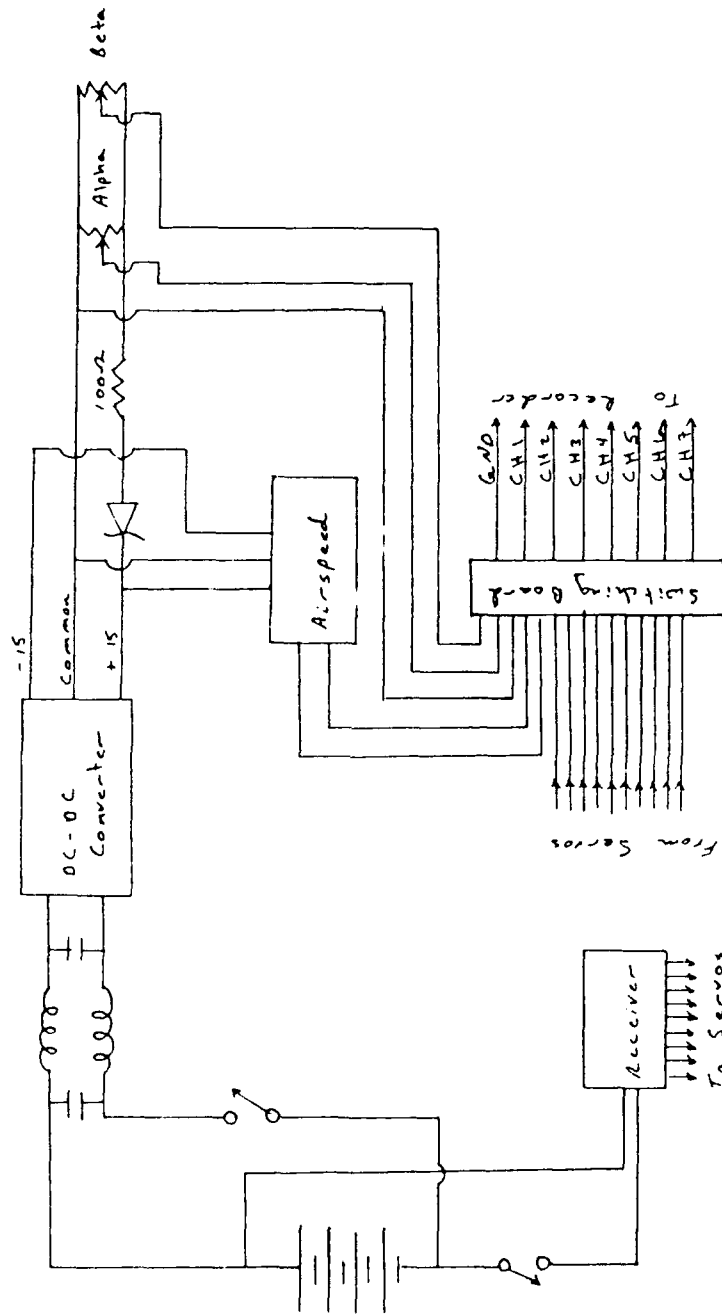

Figure B.2 Aircraft Schematic

APPENDIX C: FLIGHT TEST SHEETS

This appendix contains samples of the flight test data sheets for calibration, steady sideslips and changing c.g. locations.

PACKUP CHECKLIST

- Aircraft
 - Fuse
 - Wing
 - Tail
 - Access Covers
 - Alpha Probe
 - Pin & Nut
 - Chocks
- Starting Box
 - Bolts
 - Pump
 - Starter
 - Glow Plug Conn
 - Glow plug
- Start Batt
- Fuel
- Tool Kit
- Recorders
 - Data Tapes Batt
 - Voice Tapes Batt
 - Paper & Pencil
 - Stopwatch
- Calibration Instr.
 - VOM
 - Protractor
- Transmitter
 - X Batt
- Flight Profile
- Cleaner
 - Paper Towels
- Switching Diagram
- Walkey Talkey

CALIBRATION DATA

Test _____ Date _____

	Up/Rt	Null	Down/Lt
Rt Rud	_____	_____	_____
Rt Ail	_____	_____	_____
Elev	_____	_____	_____

	Up		Down		
	50°	30°	0°	20°	40°
Alpha	_____	_____	_____	_____	_____
	Right		Left		
	40°	20°	0°	20°	40°
Beta	_____	_____	_____	_____	_____

STEADY SIDE SLIP EXPERIMENT

Data Batt Start _____ Stop _____

TEST I T/O _____ Land _____

Run 1 L/R Start _____ End _____
Run 2 L/R Start _____ End _____
Run 3 L/R Start _____ End _____
Run 4 L/R Start _____ End _____
Run 5 L/R Start _____ End _____
Run 6 L/R Start _____ End _____

TEST II T/O _____ Land _____

Run 1 L/R Start _____ End _____
Run 2 L/R Start _____ End _____
Run 3 L/R Start _____ End _____
Run 4 L/R Start _____ End _____
Run 5 L/R Start _____ End _____
Run 6 L/R Start _____ End _____

TEST III T/O _____ Land _____

Run 1 L/R Start _____ End _____
Run 2 L/R Start _____ End _____
Run 3 L/R Start _____ End _____
Run 4 L/R Start _____ End _____
Run 5 L/R Start _____ End _____
Run 6 L/R Start _____ End _____

METRO CONDITIONS

Local Press _____ in Hg Alt _____ ft
Temp _____ °F Wind _____
Elv _____ ft
Wt of A/C _____ lb

NOTE:

DO NOT run engine over 20 min without fueling A/C!

CHANGING C.G. EXPERIMENT

Data Batt Start _____ Stop _____

TEST I T/O _____ Land _____ C.G. _____

Run 1 Start _____ End _____
Run 2 Start _____ End _____
Run 3 Start _____ End _____
Run 4 Start _____ End _____
Run 5 Start _____ End _____
Run 6 Start _____ End _____

TEST II T/O _____ Land _____ C.G. _____

Run 1 Start _____ End _____
Run 2 Start _____ End _____
Run 3 Start _____ End _____
Run 4 Start _____ End _____
Run 5 Start _____ End _____
Run 6 Start _____ End _____

TEST III T/O _____ Land _____ C.G. _____

Run 1 Start _____ End _____
Run 2 Start _____ End _____
Run 3 Start _____ End _____
Run 4 Start _____ End _____
Run 5 Start _____ End _____
Run 6 Start _____ End _____

METRO CONDITIONS

Local Press _____ in Hg Alt _____ ft
Temp _____ °F Wind _____
Elv _____ ft
Wt of A/C _____ lb

NOTE:

DO NOT run engine over 20 min without fueling A/C!

LIST OF REFERENCES

1. Sweetman,B., "Unmanned Air Vehicles Make a Comeback," International Defense Review, v. 18, n. 11, November 1985.
2. Hellman,P., "The Little Airplane That Could," Discover, February 1987.
3. Parker, CDR D. M., "The Empty Cockpit," Naval Aviation News, v. 70, n. 2, January-February.
4. National Aeronautics and Space Administration, Public Affairs Division NASA, "NASA Aeronautics," Government Printing Office, Washington, DC.
5. Lyons, D. F., Aerodynamic Analysis of a U.S. Navy and Marine Corps Unmanned Air Vehicle, Master's Thesis, Naval Postgraduate School, Monterey, CA, June 1989.
6. Bar, Irwin P., and Rumpf, Richard, "Pioneer is Operationally Capable," Aerospace America, February 1989.
7. Morrocco, John D., "Pentagon Considers Buying Additional Pioneer RPV's," Aviation Week & Space Technology, 31, July 1989.
8. Interview between Al Ellis, AAI Corporation, Hunt Valley, MD, and the author, 10, September 1990.
9. Tanner,J. C., Development of a Flight Test Methodology for a U.S. Navy Half-Scale Unmanned Air Vehicle, Master's Thesis, Naval Postgraduate Schhol, Monterey, CA, March 1989.
10. Kee, Yeho, Initial Flight Test of Half-Scale Unmanned Air Vehicle, Master's Thesis, Naval Postgraduate School, Monterey, CA, September 1989.