

AD-A 240601

WHOI-91-18

**A Compilation of Moored Current Meter Data and  
Wind Recorder Data from the Severe Environment  
Surface Mooring (SESMOOR)  
Volume XLIII**

by

Gennaro H. Crescenti, Susan A. Tarbell, and Robert A. Weller

Woods Hole Oceanographic Institution  
Woods Hole, Massachusetts 02543

July 1991

**Technical Report**

Funding was provided by the Office of Naval Research  
under Contract No. N00014-84-C-0134, NR 083-400 and Grant No. N00014-90-J-1423.

Reproduction in whole or in part is permitted for any purpose of the United States  
Government. This report should be cited as Woods Hole Oceanog. Inst. Tech. Rept.,  
WHOI-91-18.

Approved for public release; distribution unlimited.

Approved for Distribution:

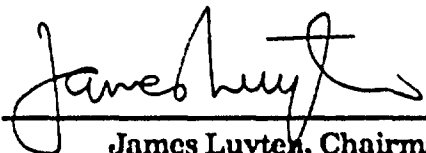

**James Luyten, Chairman**  
Department of Physical Oceanography



Administrative stamp with various fields and handwritten notations, including a checkmark and the handwritten code 'A-1' at the bottom.

## Preface

This volume is the 43rd in a series of technical reports presenting moored current meter and associated data collected by the WHOI Buoy Group. Only the volumes covering data gathered since 1978 are listed here.

A data directory and bibliography for the years 1963-1978 have been published as WHOI Technical Report 79-88.

A Technical Memorandum, WHOI-3-88, describes the current meter data processing system and its use.

Volume No.	WHOI Ref. No.	Author	Experiment
XVIII	79-65	Tarbell, S., M. G. Briscoe and R. A. Weller	1978 JASIN
XXI	79-85	Mills, C., and P. Rhines	1978 W.B.U.C
XXIII	80-40	Tarbell, S. and R. Payne	1978 POLYMODE
XXVIII	81-73	Mills, C., S. Tarbell, W. B. Owens and R. Payne	1978 L.D.E
XXIX	82-16	Levy, E. <i>et al.</i>	1979 INDEX
XXX	82-43	Levy, E., S. Tarbell and N. P. Fofonoff	1979 GSE/NSOI
XXXI	83-30	Levy, E. and S. Tarbell	1981 WESPAC
XXXII	83-46	Levy, E.	1979 Vema Channel
XXXIII	84-6	Spencer, A., D. Chausse and W. B. Owens	1981 NPBC
XXXIV	84-16	Levy, E. and P. L. Richardson	1983 SEQUAL I
XXXV	84-36	Tarbell, S., N. J. Pennington and M. G. Briscoe	1982-4 LOTUS
XXXVI	84-37	Levy, E., and P. L. Richardson	1983-4 SEQUAL II
XXXVII	85-7	Levy, E., and P. L. Richardson	1984 SEQUAL III
XXXVIII	85-39	Tarbell, S., E. T. Montgomery and M. G. Briscoe	1983-4 LOTUS
XXXIX	86-14	Levy, E., and S. Tarbell	1983-4 HEBBLE
XL	87-19	Tarbell, S., P. L. Richardson and J. Price	1984-6 Canary Basin
XLI	87-20	Levy, E., and S. Tarbell	1983-5 Zonal Pacific
XLII	90-30	Luyten, J., <i>et al.</i>	1985-7 Agulhas
XLIII	91-18	Crescenti, G. H., S. Tarbell and R. A. Weller	1988-9 SESMOOR

## Abstract

A Severe Environment Surface Mooring (SESMOOR) was designed to make long term meteorological and near surface oceanographic measurements in areas where harsh environmental conditions prevail. SESMOOR was deployed in the North Atlantic Ocean approximately 300 km southeast of Halifax, Nova Scotia for 141 days during the winter of 1988-89. Meteorological data were acquired from two Vector Averaging Wind Recorders (VAWR) located on top of a specially designed buoy mast and included air temperature, relative humidity, barometric pressure, wind velocity, solar and longwave radiation. Sea surface temperature was also acquired by the VAWRs. Current velocities and sea temperatures were obtained from two Vector Measuring Current Meters (VMCM) at 20 and 50 meters below the sea surface.

This report discusses instrument performance, data quality, pre- and post-deployment calibrations, data telemetry, data processing procedures. This report also presents the data in a variety of displays.

# Table of Contents

List of Tables . . . . .	iv
List of Figures . . . . .	v
1 Introduction . . . . .	1
2 Description of Mooring . . . . .	1
3 Description of Instrumentation . . . . .	3
4 Sensor Calibrations . . . . .	7
5 Data Identification . . . . .	11
6 Processing of Telemetered Data . . . . .	12
7 Processing of Internally Recorded Data . . . . .	19
8 Presentation of the Time Series . . . . .	21
8.1 Time Series . . . . .	21
8.2 Statistics . . . . .	21
8.3 Progressive Vectors . . . . .	21
8.4 Histograms . . . . .	22
8.5 Spectra . . . . .	22
Acknowledgments . . . . .	22
References . . . . .	49

## List of Tables

1	Severe Environment Surface Mooring Configuration . . . . .	5
2	Sensor Calibration Shifts and Resolutions . . . . .	8
3	Identification Numbers . . . . .	12
4	Data Quality Summary . . . . .	20
5	Statistics for V-161WR and V-707WR . . . . .	23
6	Least squares fit of V-707WR data as a function of V-161WR. . . . .	24
7	Statistics for VM-026 (20 m) and VM-001 (50 m) . . . . .	24

## List of Figures

1	SESMOOR location. . . . .	2
2	SESMOOR buoy configuration . . . . .	4
3	Crosstalk of sea surface temperature thermistor probes for bath test . . . . .	9
4	Crosstalk of sea surface temperature probes . . . . .	10
5	SESMOOR telemetry data for December 1988 of V-161WR. . . . .	14
6	SESMOOR telemetry data for December 1988 of V-707WR . . . . .	15
7	Differences between the telemetry data from V-161WR and V-707WR . . . . .	16
8	Telemetered wind vectors from V-161WR and V-707WR. . . . .	17
9	Telemetered water level, battery voltage and mooring tension . . . . .	18
10	V-161WR time series . . . . .	25
11	V-707WR time series . . . . .	26
12	VM-026 time series . . . . .	27
13	VM-001 time series . . . . .	28
14	V-161WR progressive wind vector plot . . . . .	29
15	V-707WR progressive wind vector plot . . . . .	30
16	VM-026 progressive current vector plot . . . . .	31
17	VM-001 progressive current vector plot . . . . .	32
18	V-161WR histograms . . . . .	33
19	V-707WR histograms . . . . .	35
20	VM-026 histograms . . . . .	37
21	VM-001 histograms . . . . .	38
22	V-161WR spectra . . . . .	39
23	V-707WR spectra . . . . .	43
24	VM-026 spectra . . . . .	47
25	VM-001 spectra . . . . .	48



# 1 Introduction

A Severe Environment Surface Mooring (SESMOOR) program was initiated at the Woods Hole Oceanographic Institution (WHOI) to demonstrate the capability of making long-term meteorological and near-surface oceanographic measurements in areas where harsh environmental conditions prevail (Kery, 1989). The Experiment on Rapidly Intensifying Cyclones over the Atlantic (ERICA) provided the opportunity for the first successful field test of SESMOOR during the winter of 1988–89.

Rapidly intensifying cyclones or “bombs” are winter events which frequent the western North Atlantic Ocean from Cape Hatteras northeast to the Grand Banks of Newfoundland (Hadlock and Kreitzberg, 1988). A bomb is defined as a storm whose central surface barometric pressure drops at least 1 millibar per hour for 24 hours at 60° N. These intense storms often exhibit hurricane strength winds accompanied with heavy precipitation. They can be particularly disruptive and destructive to maritime shipping, fishing, recreational vessels, military exercises, coastal communities, and to structures such as offshore oil rigs.

SESMOOR has demonstrated that meteorological and near-surface oceanographic data can be successfully acquired during long-term deployments in a harsh marine environment and withstand the punishing effects from exposure to these bombs.

This report describes the basic meteorological and oceanographic data acquired on SESMOOR during ERICA.

## 2 Description of Mooring

SESMOOR was deployed from the *R/V Oceanus* (cruise 203) on 17 October 1988 in 2984 meters of water. The mooring location, 42°33' N and 61°14' W (Figure 1), was east of the ERICA storm center region at the approximate latitude of

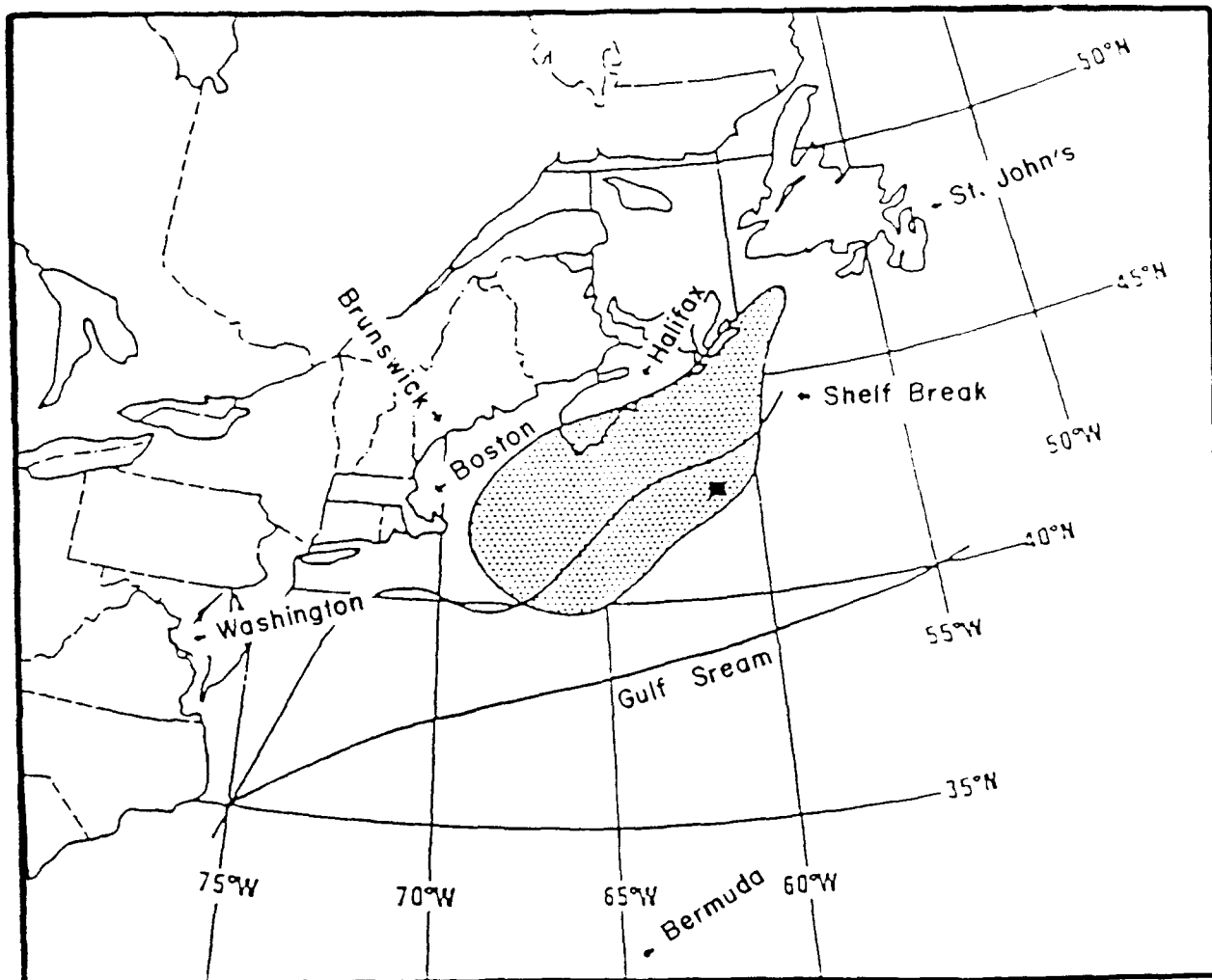

Figure 1: SESMOOR location. The mooring is located at approximately  $42^{\circ}33'N$ ,  $61^{\circ}14'W$  (black box). The stippling denotes the ERICA region in which the greatest surface atmospheric pressure falls are found for ERICA-type storms. The smoothed Continental Shelf boundary (100 fathoms) and Gulf Stream mean position (to the south) are also shown.

maximum bomb occurrence (Roebber, 1984). The mooring was recovered after 141 days at sea on 7 March 1989 by the *R/V Endeavor* (cruise 192).

The surface platform was an aluminum discus buoy, 3 meters in diameter. The meteorological sensors and data telemetry transmitters were placed on top of a single mast 3 meters above the mean water line (Figure 2).

This new design was developed to minimize icing conditions sometimes found when using the conventional tripod superstructure.

Two test cages were placed on the mooring (Table 1) for continuing evaluation of the bearings used in the current meter speed sensors. There were no meaningful results from this test as both test cages were tangled by commercial fishing lines on 26 December. The mooring included a number of dummy current meters to simulate the weight and dynamic loading of a typical scientific mooring. A complete technical description of the engineering design of SESMOOR was discussed by Kery (1989).

### 3 Description of Instrumentation

Two Vector Averaging Wind Recorders (VAWR) (Weller *et al.*, 1990; Dean and Beardsley, 1988; Payne, 1974) were placed on the buoy to measure the meteorological variables. Their WHOI designations were V-161WR and V-707WR. The measured variables were:

- sea surface temperature (Thermometrics thermistor);
- air temperature (YSI #44034 thermistor);
- relative humidity (Vaisala model 1518HM Humicap);
- barometric pressure (Paroscientific model 215AW-020 Digiquartz);
- wind speed and direction (R. M. Young model 5103 Wind Monitor on V-161WR; R. M. Young model 6101 aluminum 3-cup anemometer and WHOI-built glass reinforced plastic vane on V-707WR);

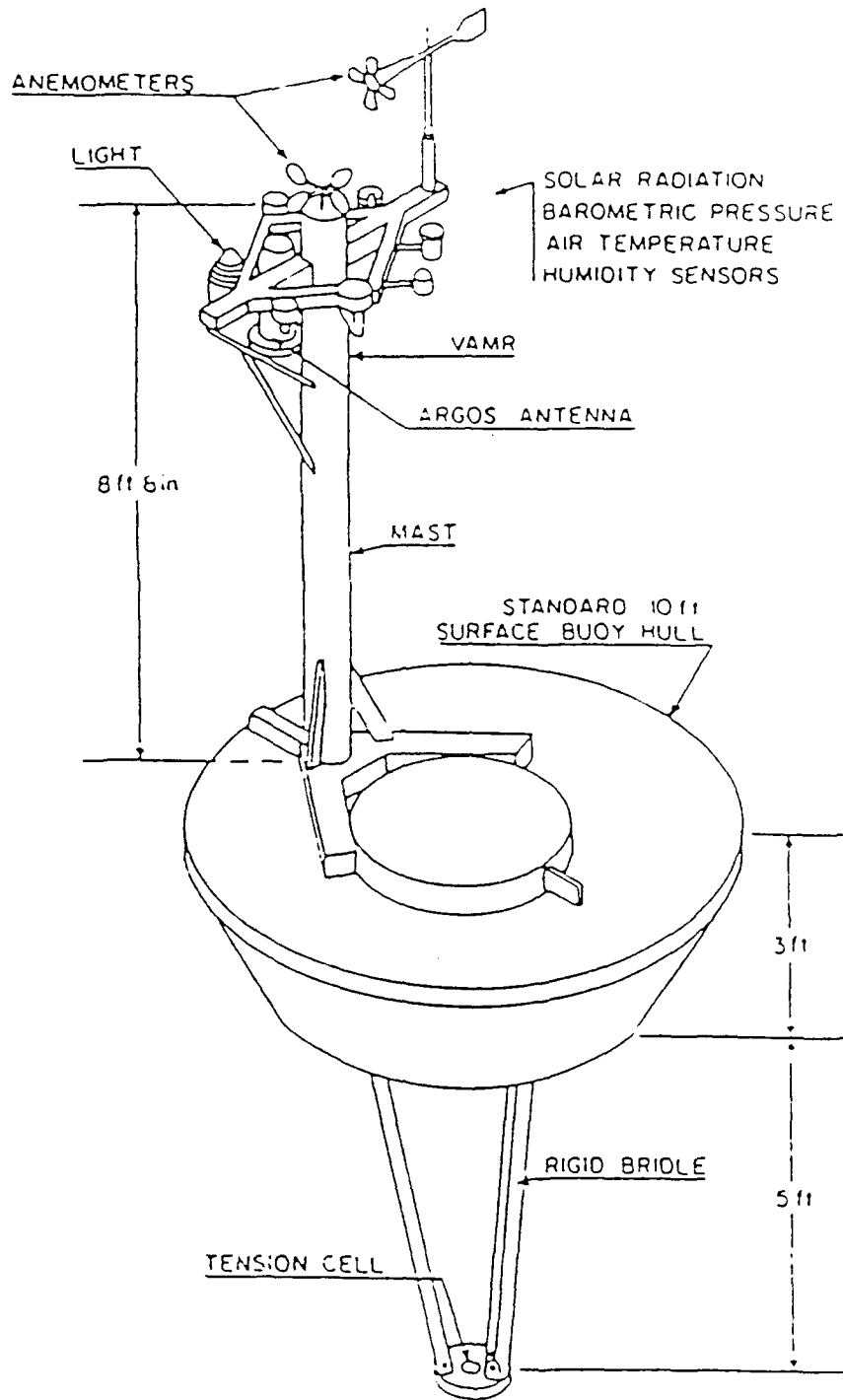

Figure 2: SESMOOR buoy configuration (from Kery, 1989)

Table 1: Severe Environment Surface Mooring Configuration

Duration: 17 October 1988 to 7 March 1989  
 Location: 42°32.96' N, 61°13.72' W  
 Magnetic Variation: 21°W

Depth (m)	Length (m)	Item	Instrument No.	Data Identifier
-3		VAWR	V-161WR	876S1
-3		VAWR	V-707WR	876S2
		PTT	04577	
		PTT	04660, 04661	
	7	3/4" chain		
10		test cage		
	2	3/4" chain		
15		dummy VMCM		
	2	3/4" chain		
20		VMCM	VM-026	8763
	7	1/2" wire		
30		test cage		
	17	1/2" wire		
50		VMCM	VM-001	8764
	17	1/2" wire		
70		dummy VMCM		
	17	1/2" wire		
90		dummy VMCM		
	107	1/2" wire		
200		dummy VMCM		
	500	3/8" wire		
	500	3/8" wire		
	300	3/8" wire		
	500	3/16" nylon		
	2	2 17" glass balls*		
	500	3/16" nylon		
	150	3/16" nylon		
	2	2 17" glass balls*		
		engineering instrument		8765
	52	22 17" glass balls*		
	2	1/2" chain		
		acoustic release		
	3	1/2" chain		
	20	1" nylon		
	5	1/2" chain		
2984		anchor		

(7300 lbs wet weight; 8850 lbs dry weight)

\* with super ribbed hardhats

- incident solar radiation (Eppley model 8-48 Black and White Pyranometer):
- downward longwave radiation (Eppley model PIR pyrgeometer).

The data from these sensors were recorded internally on magnetic cassette tapes as 15-minute averages. Selected variables from the last 15-minute average of each hour from both VAWRs were stored in an internal buffer, then were transmitted to one of the NOAA satellites when it passed overhead. The transmitted data were accumulated and stored by Service Argos prior to data processing at WHOI.

Oceanographic data were acquired with two Vector Measuring Current Meters (VMCM) (Weller and Davis, 1980) that were placed in the mooring line to measure current velocity and water temperature at 20 and 50 m below the sea surface. Their WHOI designations were VM-26 and VM-01, respectively.

The VMCM was developed at the Scripps Institution of Oceanography in the 1970's and is manufactured by EG&G Ocean Products, Inc. Each VMCM has a pair of orthogonally mounted propellers designed to have an accurate co-sinusoidal response and measure the two horizontal components of velocity. The instrument uses microprocessor technology and calculates east and north components of velocity every 0.25 seconds based on the number of propeller revolutions and the compass reading. The vector and propeller values are accumulated for a specified length of time (7.5 minutes for SESMOOR) and then recorded on magnetic tape. A record count (clock), an instantaneous compass value and sea temperature are also recorded.

Two transmitters were placed on SESMOOR. Each transmitter was activated by WHOI designed and built controllers. One transmitter sent engineering data such as battery voltage and mooring tension. The other transmitter had been assigned two platform numbers. This transmitter sent selected data from each VAWR.

## 4 Sensor Calibrations

In order to assure that the data taken on SESMOOR was reliable, pre- and post-deployment calibrations were taken of all VAWR sensors. For the most part, only small or negligible drifts were found. Detailed discussions of the VAWR accuracy, reliability, precision, and resolution were documented by Weller *et al.* (1990) in the Frontal Air-Sea Interaction Experiment (FASINEX). A summary of the calibration shifts and resolution of each meteorological sensor is presented in Table 2. The thermistors for sea surface temperature measurements showed a very small calibration shift during the deployment. The sea surface temperature showed a calibration shift of  $-0.0020^{\circ}\text{C}$  and  $-0.0011^{\circ}\text{C}$  in the range of  $0^{\circ}$  to  $30^{\circ}\text{C}$  for V-161WR and V-707WR, respectively. The thermistors for air temperature also showed a very slight drift of  $-0.0021^{\circ}\text{C}$  and  $-0.0005^{\circ}\text{C}$  over the range of  $-20^{\circ}$  to  $+30^{\circ}\text{C}$ . All thermistor calibrations were conducted at a WHOI calibration facility.

An anomalous signal was noticed during post-deployment processing of the sea surface temperature data. It was discovered in subsequent bath tests that a "crosstalk" problem existed. Figure 3 displays an example of this crosstalk error for a bath test at  $5^{\circ}\text{C}$  for the two thermistors. These thermistor wires had shared an unshielded cable after they passed through the bottom of the buoy. The size of the crosstalk signal varies as the oscillators drift in and out of phase. The AC excitation to one sensor modulates the signal to the other sensor (J. Dean, personal communication, 1989). The total uncertainty of this crosstalk error was as large as  $0.2^{\circ}\text{C}$  during some instances of the mooring deployment (Figure 4). This problem has been recognized and will be avoided in future buoy designs.

Post-calibration of the first relative humidity sensor (V-161WR) was not possible since it was accidentally destroyed during the mooring recovery process. To further complicate matters, the second humidity sensor (V-707WR) began showing signs of significant calibration drift after the passage of a strong bomb on

Table 2: Sensor Calibration Shifts and Resolutions

	V-161WR		V-707WR	
	Calibration Shift	Resolution	Calibration Shift	Resolution
Sea Surface Temperature	-0.0020°C	< 0.0001°C	-0.0011°C	< 0.0001°C
Air Temperature	-0.0021°C	< 0.0001°C	-0.0005°C	< 0.0001°C
Relative Humidity		0.05% RH		0.05% RH
Barometric Pressure	-0.005 mb	0.1 mb	+0.063 mb	0.1 mb
Wind Speed	+0.78%	0.0003 m s <sup>-1</sup>	-3.48%	0.0004 m s <sup>-1</sup>
Wind Direction		2.8125 deg		2.8125 deg
Solar Radiation	-2.75%	0.0014 W m <sup>-2</sup>	-0.92%	0.0017 W m <sup>-2</sup>
Longwave Radiation	-5.91%	0.004 W m <sup>-2</sup>	-8.01%	0.004 W m <sup>-2</sup>

Post cruise - Bath temperature = 4.9906 c.

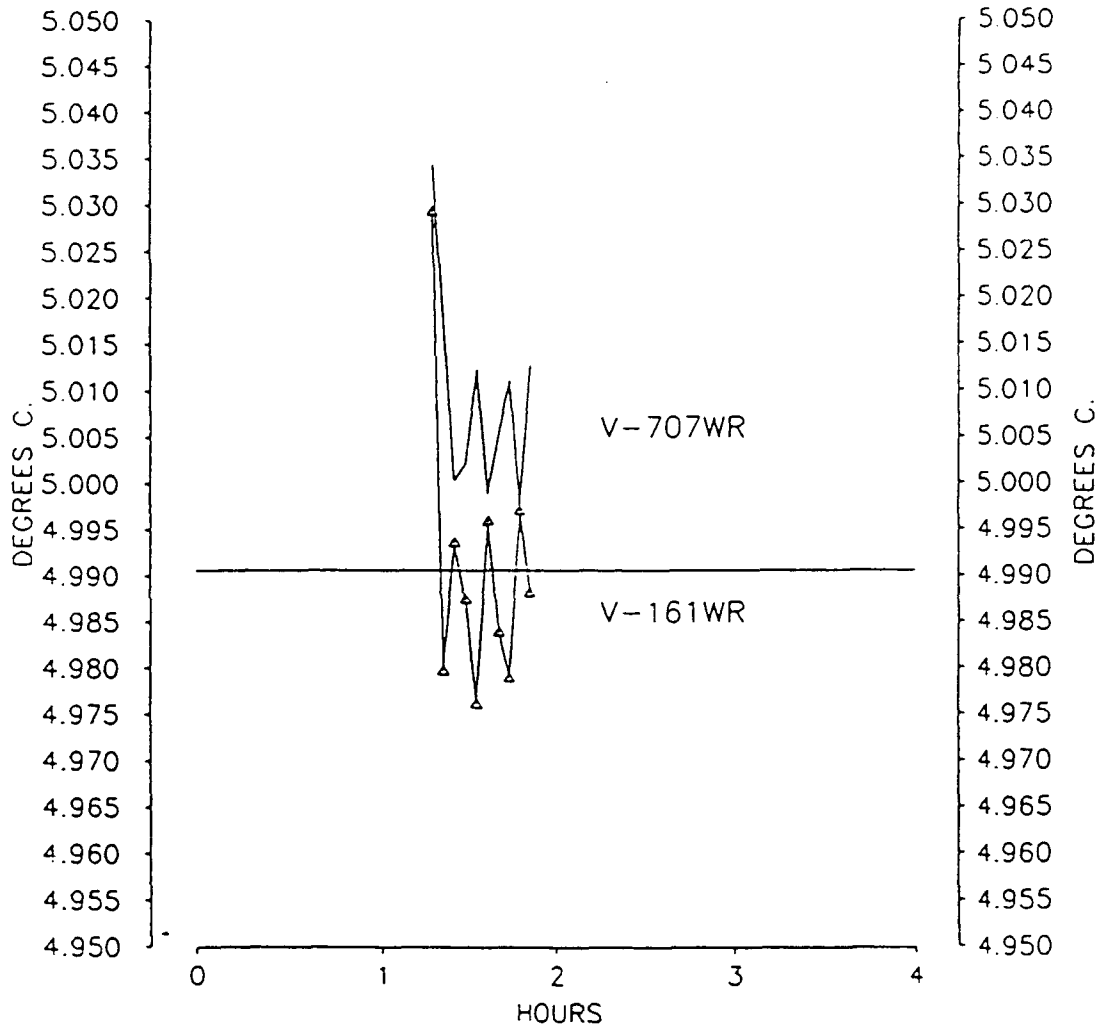

Figure 3: Crosstalk of sea surface temperature thermistor probes for bath test at 5°C.

# SESMOOR

V-161WR = LINE \* V-707WR = line with triangle

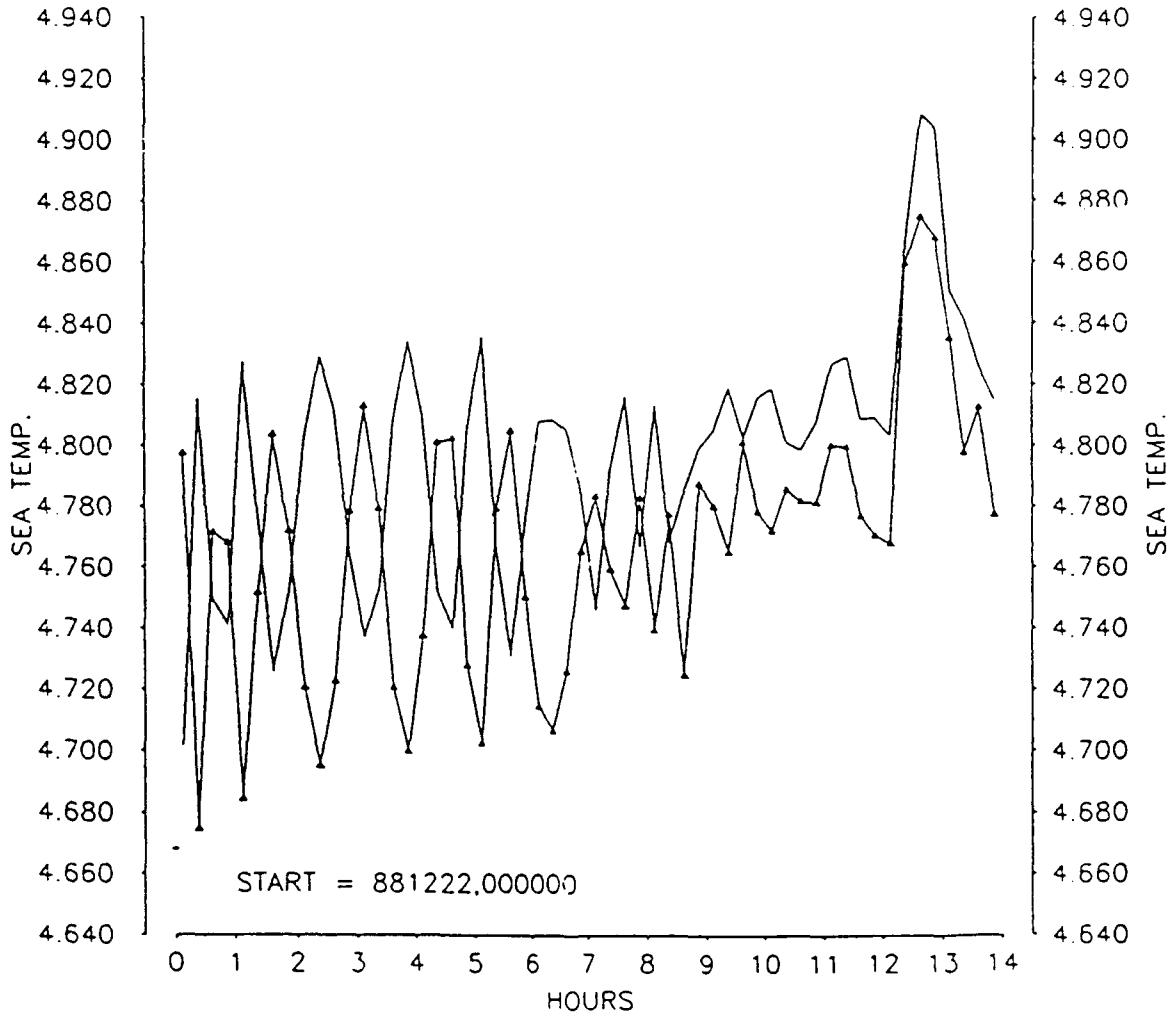

Figure 4: Crosstalk of sea surface temperature thermistor probes during SESMOOR deployment.

4 January 1989. Although the second sensor never completely failed in its operation during the deployment, a post-calibration showed anomalous behavior at relative humidities greater than 50% RH.

The relative humidity data was not totally lost, however. Examination of the raw frequency output signal of the first sensor showed no apparent shift with time of the maximum peak values during saturation episodes. Thus, a slightly adjusted original calibration was used to obtain a relative humidity time series. The second sensor also showed the same stability during the first half of the deployment, and for that segment, the original calibration was used. The data from the second half of the deployment was considered useless and was discarded. Calibrations of these sensors were performed at WHOI.

At one point during the experiment, ERICA storm forecasters questioned the reliability of the barometric pressure sensors on SESMOOR. However, both sensors showed excellent stability in the field. Calibration shifts of  $-0.005$  and  $+0.063$  mb were found for the Paroscientific digiquartz sensors on V-161WR and V-707WR, respectively. The pre- and post-calibrations were performed by Paroscientific, Inc.

A calibration shift of  $+0.78\%$  was found in the R. M. Young wind monitor while a  $-3.48\%$  shift was observed for the aluminum cups. These calibrations were performed by the R. M. Young Company.

Both Eppley pyranometers showed negative drifts of  $-2.75\%$  and  $-0.92\%$  for V-161WR and V-707WR, respectively. The pyrgeometers also showed negative drifts of  $-5.91\%$  and  $-8.01\%$ , respectively. All of the pre- and post-calibrations of the radiation sensors were determined by Eppley, Inc.

## 5 Data Identification

WHOI Buoy Group data are identified by a mooring number, a sequential instrument position number, a letter to indicate the data version and numbers to

Table 3: Identification Numbers

Instrument	Instrument ID	Height from Mean Sea Level (m)	Sea Data ID	Transmitted ID
VAWR	V-161WR	3	876S1	876T1
VAWR	V-707WR	3	876S2	876T2
VMCM	VM-26S	-20	8763	
VMCM	VM-01	-50	8764	

indicate the sampling rate. For example, 8763B450 identifies data from the third instrument on mooring 876. The version is B and the sampling rate is one record every 7.5 minutes (450 seconds). 8763B1HG24 is a time series that has had a Gaussian filter applied to the data. The filter has a half width of 24 hours (G24) and is subsampled once an hour (1H).

Instruments that record on the surface platform have their position number preceded by the letter S. 876S1F900 would be the first instrument on mooring 876, positioned on the surface buoy and with a sampling rate of 15 minutes (900 seconds).

Telemetered data has its instrument position number preceded by a T. Therefore, 876T1 indicates that the data in that time series had been telemetered. This mooring had 4 instruments listed above in Table 3.

## 6 Processing of Telemetered Data

There were two platform transmitter terminals (PTT) on SESMOOR. The first PTT (04577) sent 8 characters that included battery voltage and tension. The second PTT used two logical identification numbers (04660, 04661). PTT-04660 and PTT-04661 identified the data from V-161WR and V-707WR, respectively. The 64 characters transmitted from each ID were apportioned as follows: hour (2); sea

surface temperature (6); air temperature (6); relative humidity (4); barometric pressure (4); east resultant wind velocity (6); north resultant wind velocity (6); anemometer rotor counts (6); solar radiation (6); longwave radiation (6); engineering data (8); and a checksum (4).

The 8 engineering characters were hour dependent. That is, each hour a different pair of engineering parameters was sent. For instance, hour 22 provided the engineers with the temperature of the controller (4) and the average tension (4).

Data from the buoy transmitters was sent *via* NOAA satellites to Service Argos receiving stations. The data was then accessed using two different methods.

In the first method, an IBM compatible PC using a Unix operating system at WHOI dialed the Service Argos computer in Maryland every two hours and retrieved the latest information. The PC was used as a database into which the ERICA storm forecasters were able to dial and use the data in a near real time fashion to help determine storm location, strength and movement.

In the second method, Service Argos accumulated the data and each morning sent the accumulated files from the previous day over the SPAN network to a VAX computer at WHOI. Also each morning automated procedures decoded, edited and sorted the variables, making daily "look" files available for the user. Those variables were stored and plotted in monthly segments. Each month seven plots were created displaying the transmitted engineering and scientific data. Occasional 24-hour gaps were caused by a variety of transmission failures between Service Argos and the VAX. In such an event, we could request a retransmission of that data.

A one month example is shown in the next several figures. In Figures 5 and 6, the time series of all the variables are shown for the month of December. The absolute difference time series between the two VAWRs is shown in Figure 7. Wind vectors are displayed in Figure 8 while engineering data (*i.e.*, water level, battery voltage, mooring tension) are shown in Figure 9.

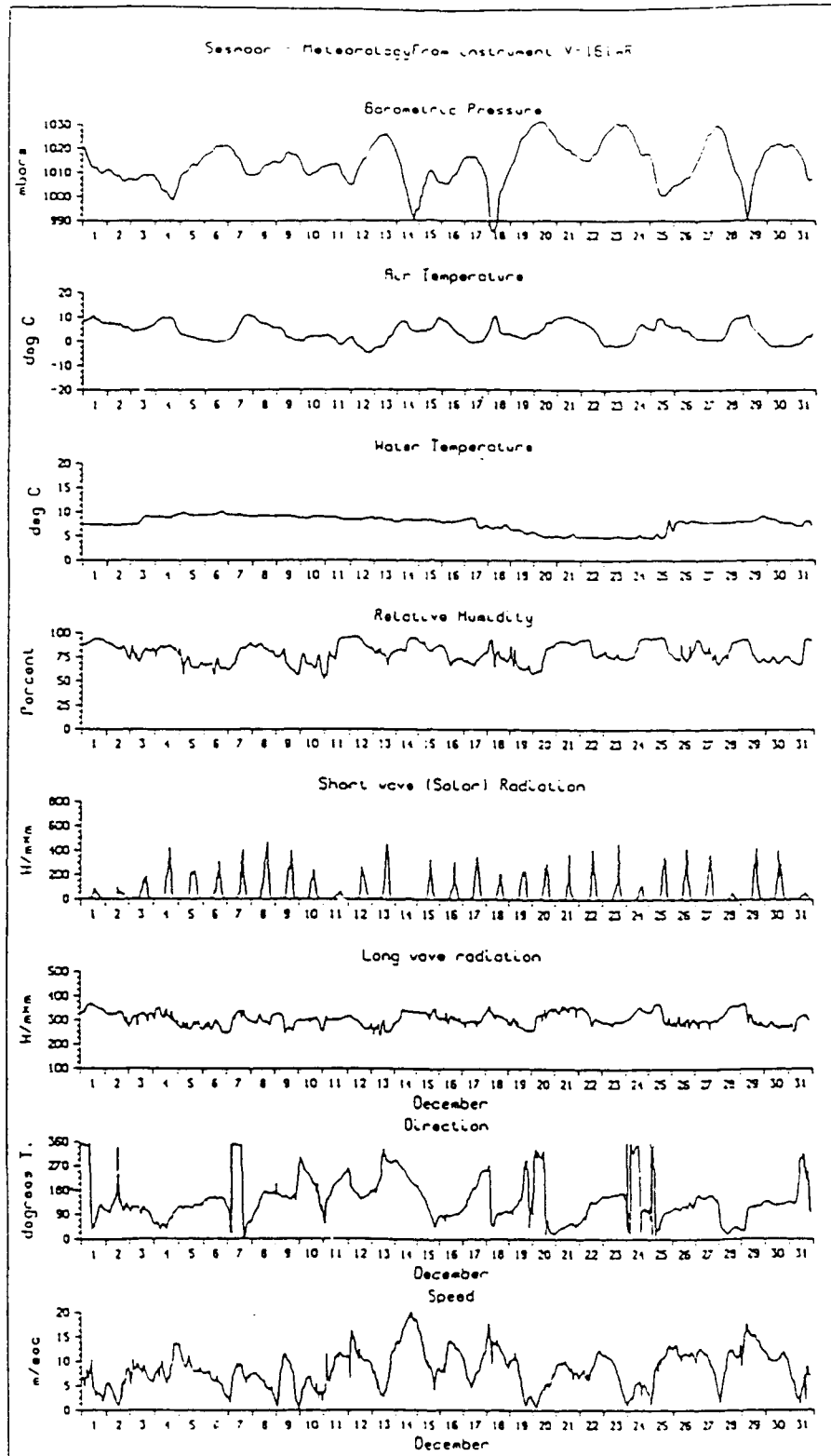

Figure 5: SESMOOR telemetry data for December 1988 of V-161WR.

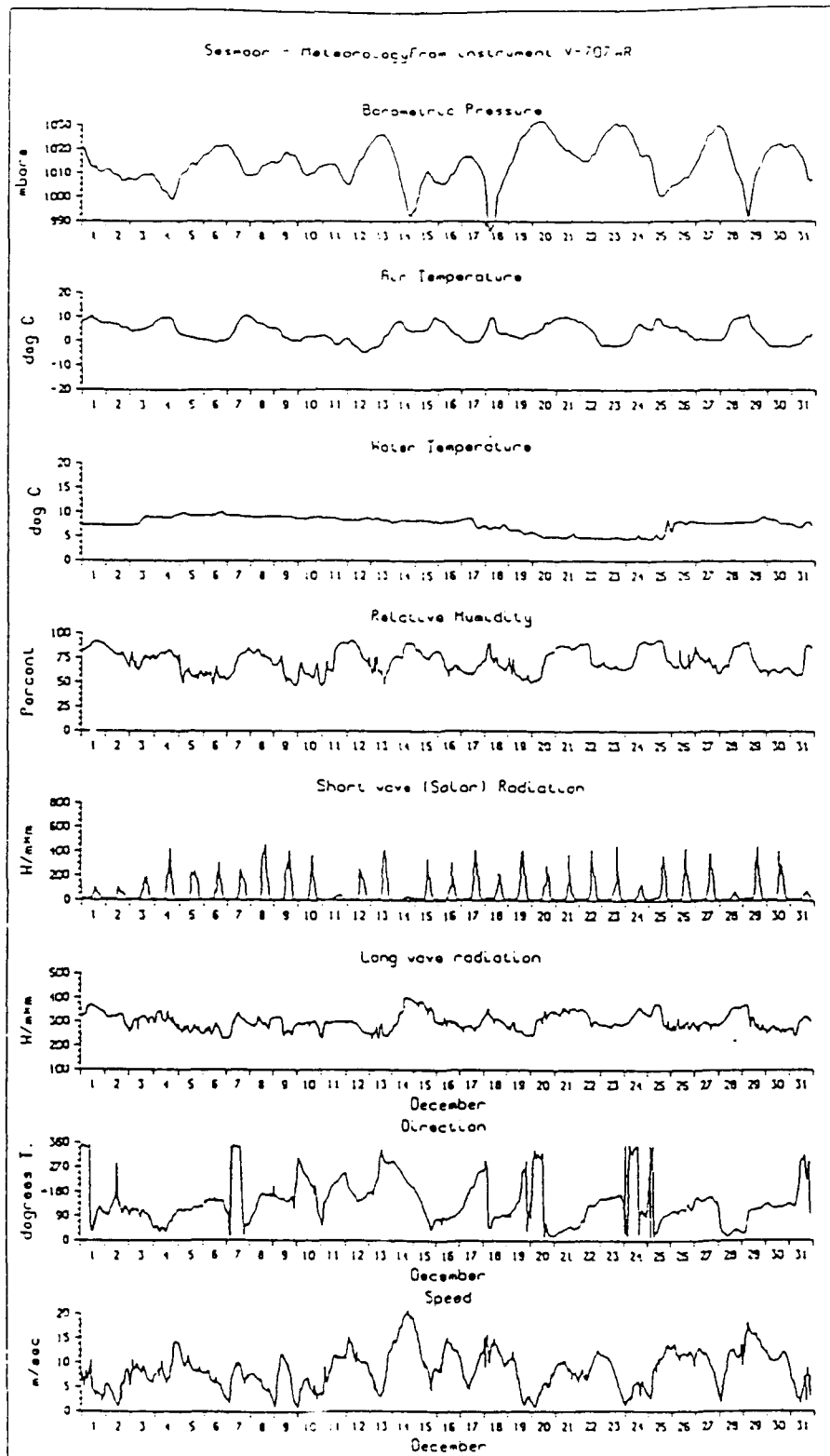

Figure 6: SESMOOR telemetry data for December 1988 of V-707WR.

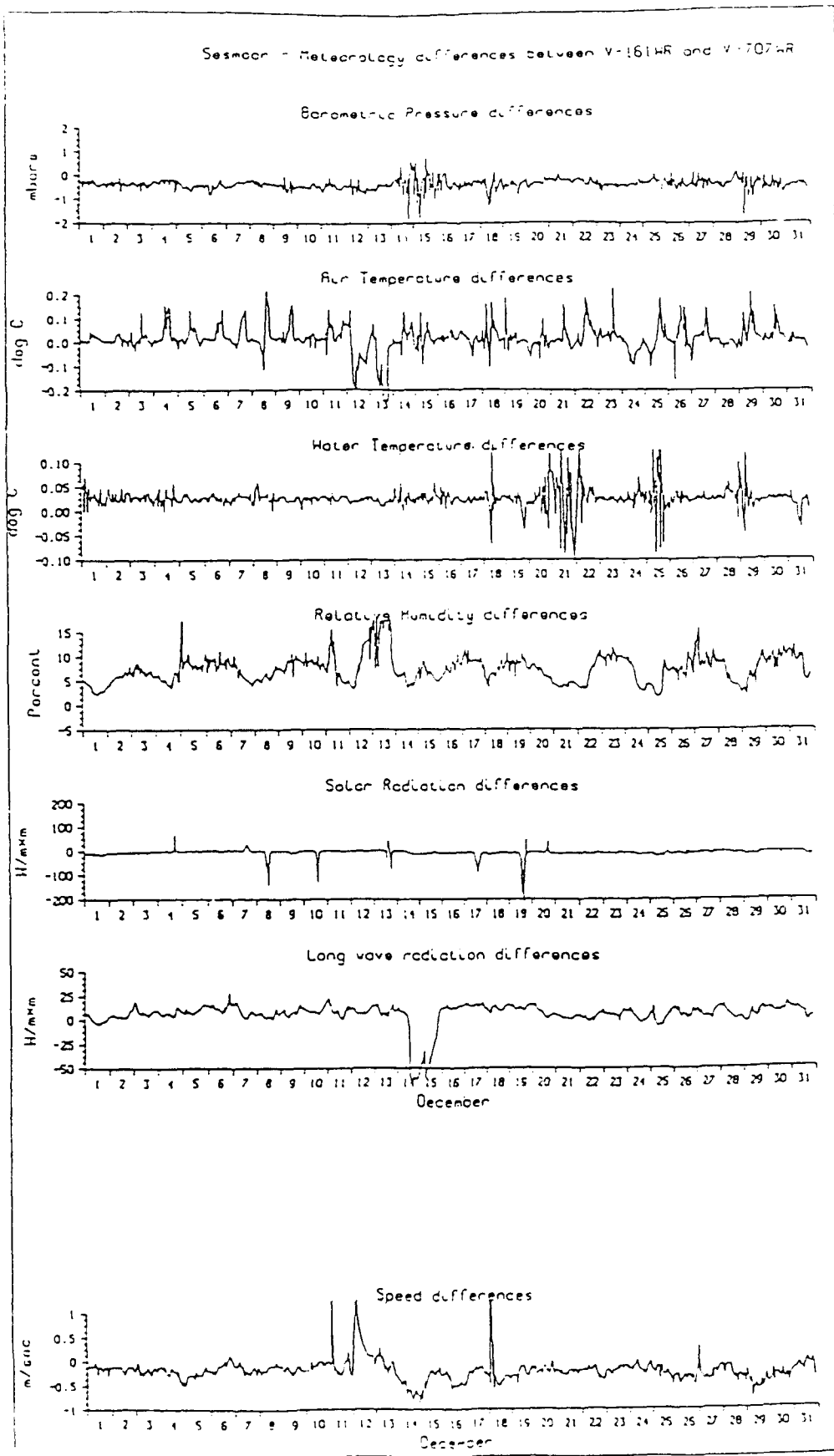

Figure 7: Absolute differences between the telemetry data from V-161WR and V-707WR for December 1988.

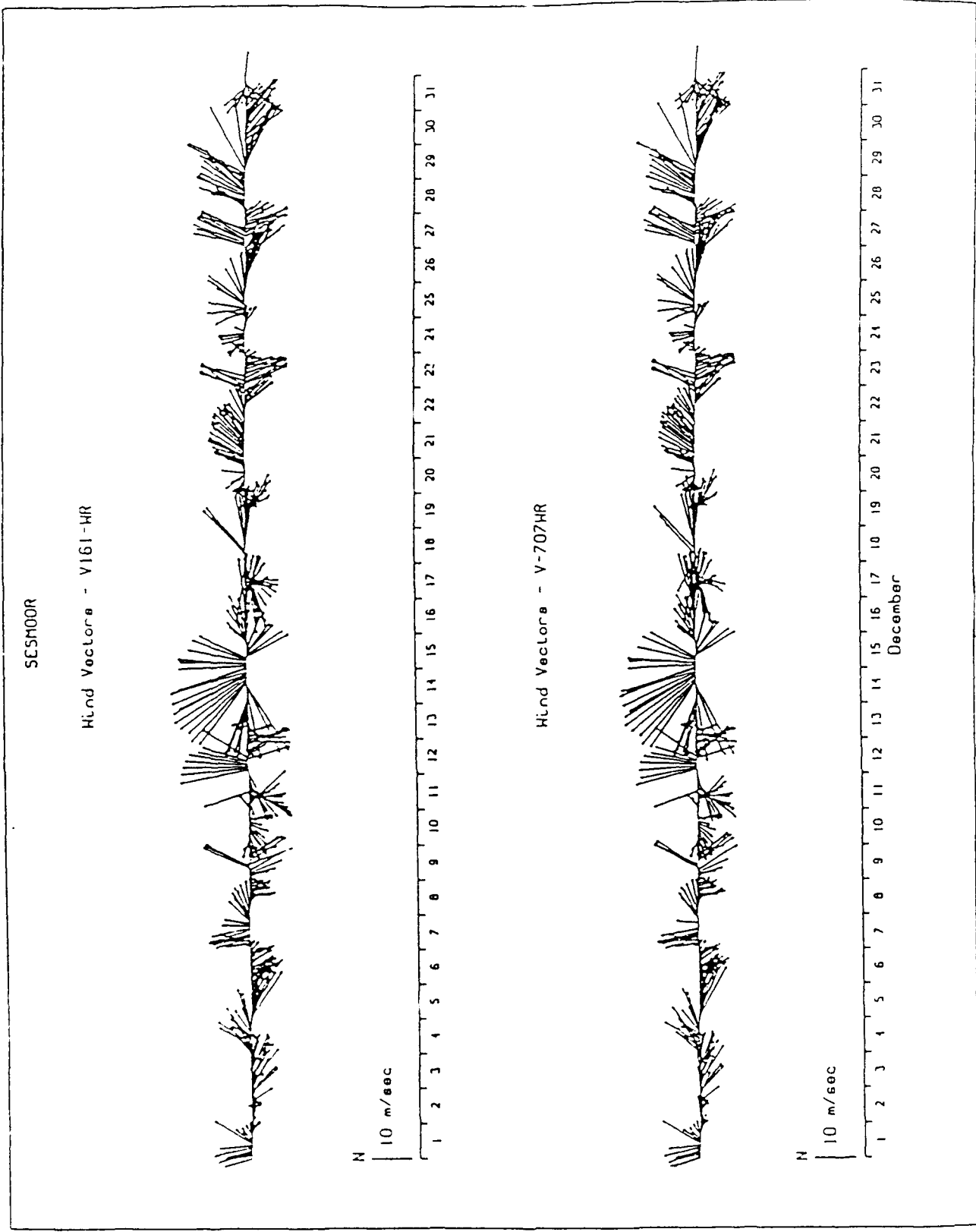

Figure 8: Telemetered wind vectors for December 1988 from V-161WR and V-707WR.

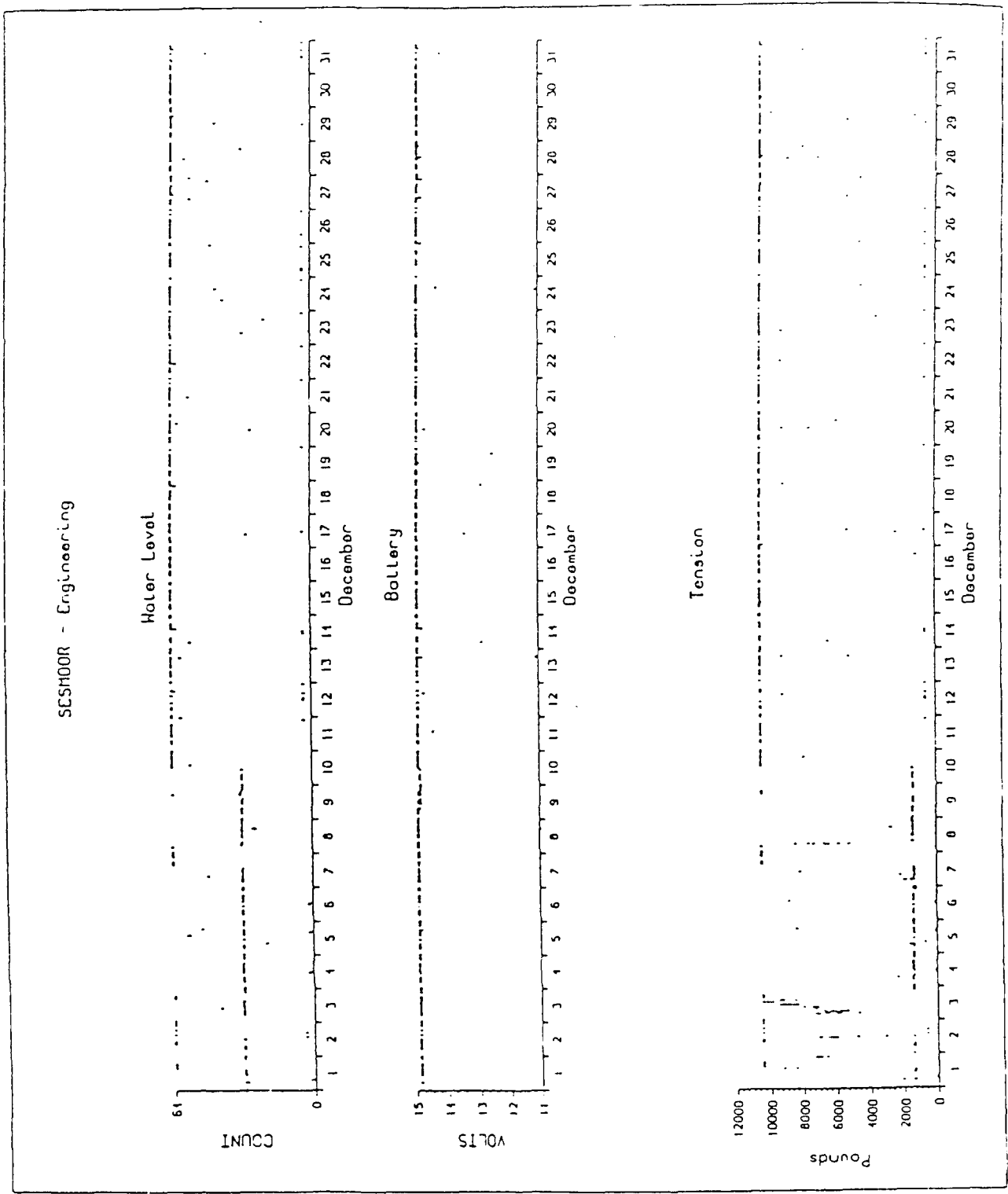

Figure 9: Telemetered water level, battery voltage and mooring tension from SES-MOOR during December 1988.

Part of the challenge of handling telemetered data was being able to determine data quality over the course of the experiment. Erroneous wild points or "spikes" were easy to identify, however, subtle drifts in sensor calibration (like that seen in the relative humidity sensor on V-707WR) were more difficult to identify.

## 7 Processing of Internally Recorded Data

After the recovery of the mooring, data from the instrument cassette tapes were transcribed to a 9-track magnetic tape using an LSI-11 computer. The data were then transferred from 9-track tape to disc on a VAX computer in the BUOY format.

Each time series went through a sequence of programs (Tarbell *et al.*, 1988) that checked the time base and converted the data into scientific units. The quality of the data was then determined for instrument performance. Miscellaneous bad data points were removed and the series were truncated by removing the launch and retrieval transients. Gaps in the data were linearly interpolated to create an evenly spaced time series. This series is known as the BBV (Best Basic Version) and is usually the basis for all further processing. However, for this experiment post-deployment calibrations were done on the all of the VAWR meteorological sensors.

The BBV for the VMCMs used the pre-deployment temperature calibrations. The BBV for the VAWRs use post-deployment calibration values for all sensors, including the wind speed sensors. Table 4 summarizes the data quality obtained on SESMOOR.

A low passed version of the data was created for plotting purposes by applying a Gaussian filter with a half-width of 24 hours, then subsampling the filtered series once an hour.

Table 4: Data Quality Summary

Series	Variable	Comments
876S1	sea temperature	see Section 4 about crosstalk
	air temperature	good
	relative humidity	special Crescenti calibration used
	barometric pressure	good
	wind velocity	good
	solar radiation	good
	longwave radiation	good
876S2	sea temperature	see Section 4 about crosstalk
	air temperature	good
	relative humidity	special Crescenti calibration used
	barometric pressure	good
	wind velocity	good
	solar radiation	good
	longwave radiation	good
8763	sea temperature	good
	current speed	good until 26 December, see Note 1
8764	sea temperature	good until 21 November, see Note 2
	current speed	good until 26 December, see Note 1

Note 1: No velocity data after 26 December 1988. The propellers were tangled by commercial fishing lines.

Note 2: A tension event on 21 November 1988 caused a minuscule leak in the instrument. The water affected the compass and temperature electronics. The temperature data have been included in this report but should be considered questionable.

## 8 Presentation of the Time Series

A series of programs were executed on the BBV data. The result is a series of plots and statistics which are presented on the following pages.

### 8.1 Time Series

The time series plots shown in Figures 10 and 11 are from the Gaussian filtered series acquired by V-161WR and V-707WR, respectively. The stick plots, which show individual current vectors along the time scale, are rotated so that east is up. Figures 12 and 13 are current meter time series at 20 and 50 m, respectively.

### 8.2 Statistics

The statistics for each variable from the basic time series are presented in the following tables. The equations used to derive the statistical parameters are described in Tarbell *et al.* (1988). Table 5 is the statistics for V-161WR and V-707WR, respectively. Table 6 summarizes least squares fit coefficients between the two VAWRs. Table 7 is the statistics for the current meters at 20 and 50 m, respectively.

### 8.3 Progressive Vectors

Wind and current vectors from two hour averages are placed head to tail to show the path a particle would have traveled in a perfectly homogeneous flow. The plot begins with an asterisk followed by annotated triangles at the first of each month, except for 8764 which has annotation every fifth day. Figures 14 and 15 are progressive wind vectors while Figures 16 and 17 are progressive current vectors.

## 8.4 Histograms

The histograms of major variables are plotted as frequency of occurrences. There are 100 bins in the x-axis of all variables. Because the VMCM velocities are short, two temperature histograms are plotted. The first for the length of the velocity record, the second for the full 141 days of deployment. Figures 18 and 19 show a series of histograms for the VAWRs while Figures 20 and 21 show histograms for the VMCMs.

## 8.5 Spectra

Plots of auto-spectra for the east and north component of velocity and the temperature are shown. Further information about the program used to create these plots may be found in the WHOI program report PROSPECT (Hunt, 1982). The data is prewhitened and recolored. Program PROSPECT allows averaging in increasingly large groups. VAWR spectra are shown in Figures 22 and 23. VMCM spectra are shown in Figures 24 and 25.

## Acknowledgments

Thanks go out to the many people at WHOI who designed, constructed and deployed SESMOOR. The success of this project is a credit to all those talented people. Thanks to William Horn for his work on calibrating all of the temperature thermistor probes and to Dr. Richard E. Payne for calibrating the relative humidity sensors. Thanks also to Jerome Dean for pointing out the crosstalk error. Special thanks to Penny Foster for her help preparing this report.

This work was funded by the Office of Naval Research under contract N00014-84-C-0134, NR 083-400 and grant N00014-90J-1423.

Table 5:

Statistics for V-161WR and V-707WR from 17 October 1988 to 7 March 1989 (13548 records). Variables include sea surface temperature (ST), air temperature (AT), relative humidity (RH), barometric pressure (BP), east wind velocity (EA), north wind velocity (NO), wind speed (WS), solar radiation (SW), and longwave radiation (LW).

## V-161WR

Variable	Minimum	Maximum	Mean	Variance	Kurtosis	Skewness
ST	0.88	16.69	7.26	25.81	1.575	0.358
AT	-8.68	18.62	4.68	31.49	2.421	0.323
RH	48.46	99.88	81.44	120.12	2.175	-0.197
BP	970.57	1041.14	1015.42	106.32	3.878	-0.568
EA	-23.06	18.55	2.90	37.27	3.019	-0.434
NO	-20.67	17.07	-1.37	35.52	2.611	0.123
WS	0.06	23.98	8.27	14.65	2.715	0.202
SW	0.00	744.08	65.33	15816.60	8.130	2.323
LW	199.46	394.79	293.58	1279.69	2.787	0.208

## V-707WR

Variable	Minimum	Maximum	Mean	Variance	Kurtosis	Skewness
ST	0.87	16.68	7.24	25.73	1.575	0.360
AT	-8.63	18.54	4.66	31.52	2.420	0.322
RH*	43.00	100.24	71.90	153.88	2.245	0.351
BP	971.02	1041.71	1015.86	107.06	3.869	-0.562
EA	-17.96	18.78	2.89	37.25	2.917	-0.374
NO	-20.64	17.39	-1.01	34.12	2.625	0.078
WS	0.13	20.71	8.16	14.11	2.707	0.245
SW	0.00	738.37	64.40	16030.11	8.010	2.321
LW	190.87	387.37	284.58	1342.45	2.626	0.259

\* 17 October 1988 to 4 January 1989 (7521 Records)

Table 6: Offset (A), slope (B), correlation coefficient (r), and standard error (SE) of least squares fit of V-707WR data as a function of V-161WR.

	A	B	r	SE
Sea Surface Temperature (C)	-0.01	0.998	1.0000	0.03
Air Temperature (C)	-0.02	1.000	0.9999	0.06
Relative Humidity (%RH)*	-15.62	1.126	0.9747	2.78
Barometric Pressure (mb)	-2.74	1.003	0.9997	0.26
East Wind ( $\text{m s}^{-1}$ )	-0.00	0.998	0.9981	0.38
North Wind ( $\text{m s}^{-1}$ )	0.34	0.978	0.9979	0.38
Resultant Wind Speed ( $\text{m s}^{-1}$ )	0.07	0.979	0.9969	0.30
Solar Radiation ( $\text{W m}^{-2}$ )	-1.48	0.995	0.9785	31.90
Longwave Radiation ( $\text{W m}^{-2}$ )	1.11	0.966	0.9428	12.24

\* 18 October through 31 December 1988

Table 7: Statistics for VM-026 (20 m) from 18 October 1988 to 26 December 1988; and VM-001 (50m) from 18 October 1988 to 21 November 1988

Variables include sea temperature (ST), east current velocity (EA), north current velocity (NO), and current speed (VS).

Statistics for VM-026 (20 m), 13297 records.

Variable	Minimum	Maximum	Mean	Variance	Kurtosis	Skewness
ST	4.50	17.46	11.48	12.42	1.670	-0.308
EA	-79.29	57.95	-7.05	371.52	3.567	-0.343
NO	-87.11	45.84	-6.31	389.07	4.011	-0.643
VS	0.07	93.83	24.53	248.15	4.350	1.162

Statistics for VM-001 (50 m), 6537 records.

Variable	Minimum	Maximum	Mean	Variance	Kurtosis	Skewness
ST	6.95	19.30	13.86	7.04	2.102	-0.254
EA	-34.44	44.95	-2.12	241.49	2.379	0.333
NO	-29.44	38.63	1.61	141.70	2.547	-0.019
VS	0.28	48.42	17.84	72.06	2.600	0.310

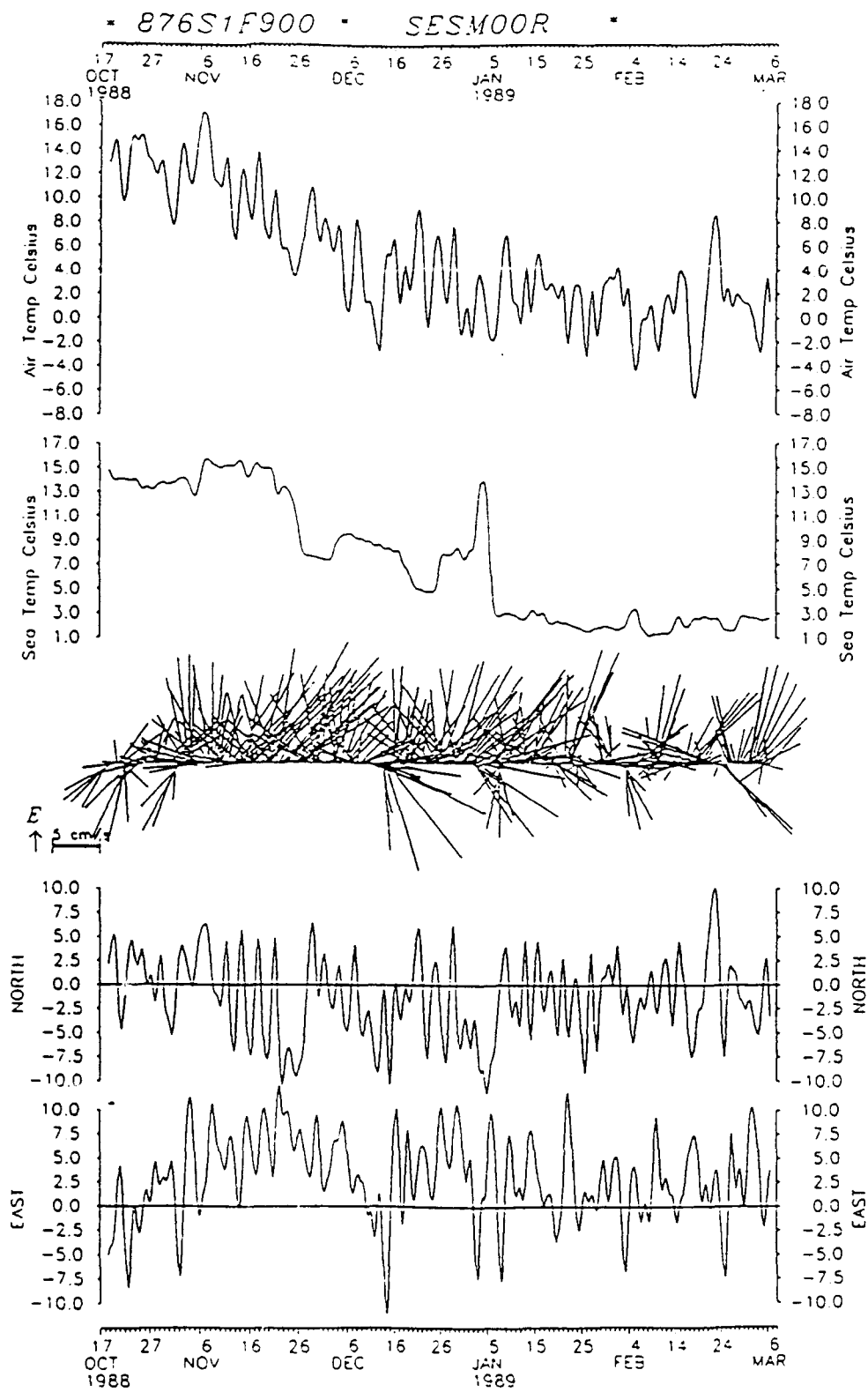

Figure 10: V-161WR time series

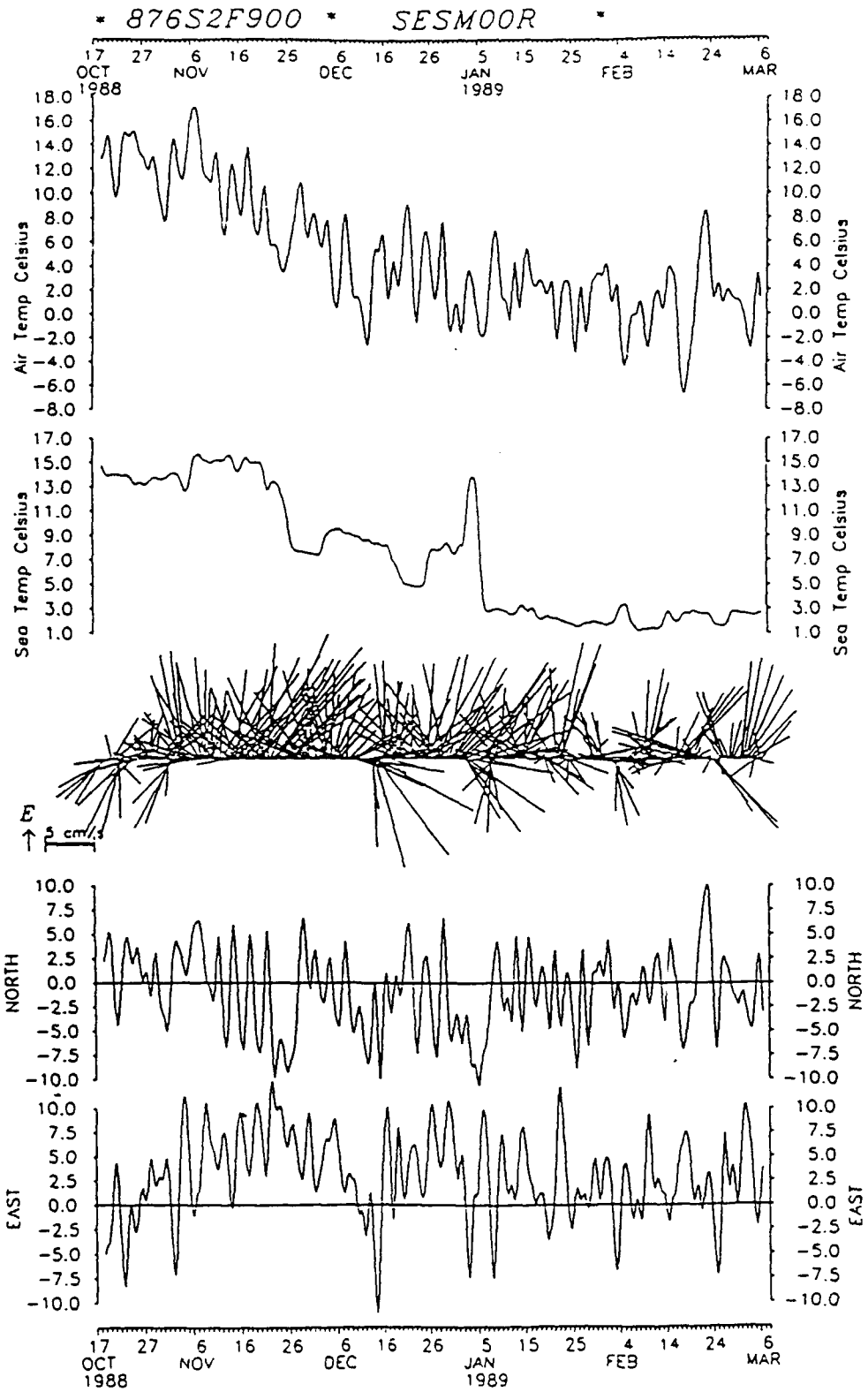

Figure 11: V-707WR time series

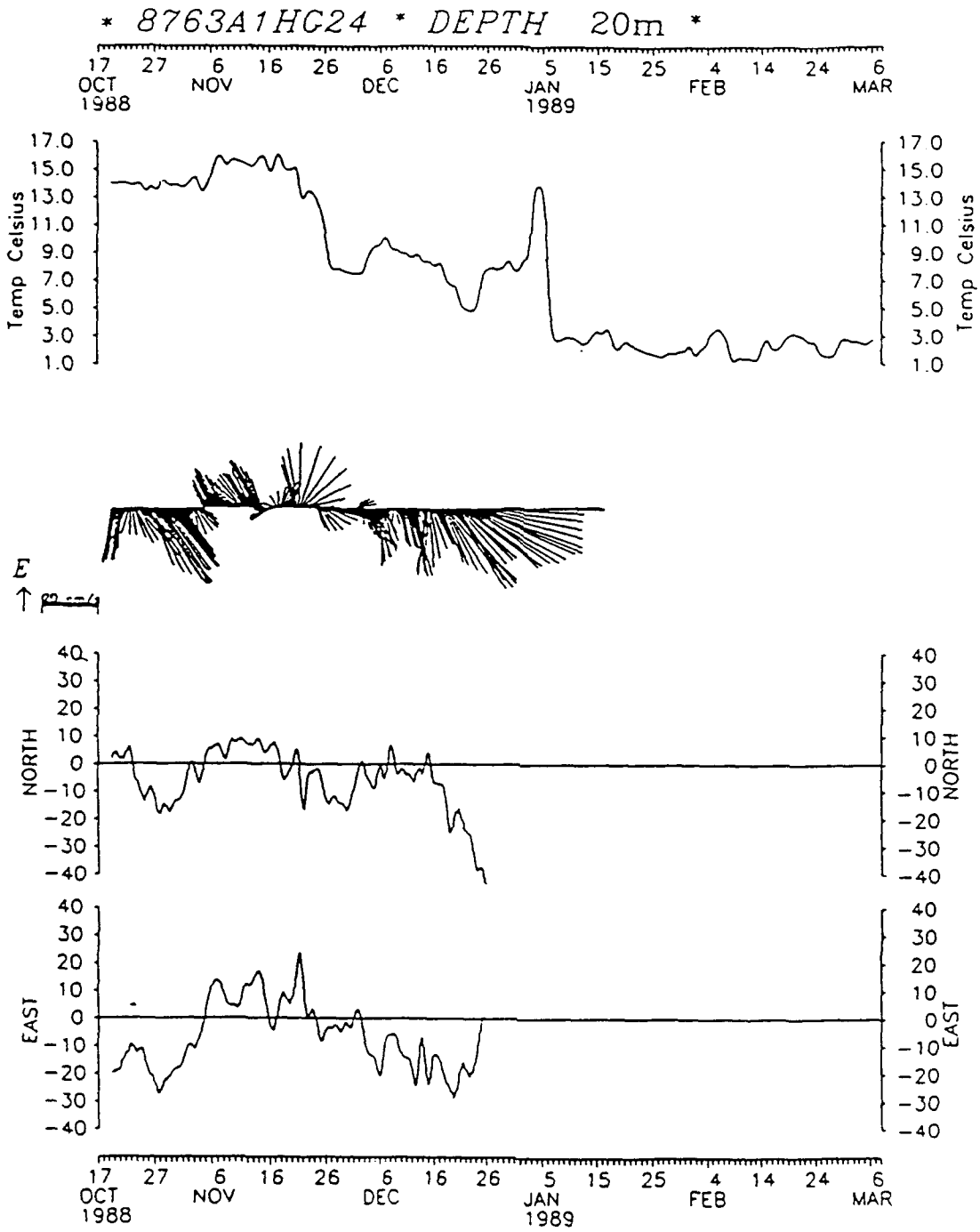

Figure 12: VM-026 time series

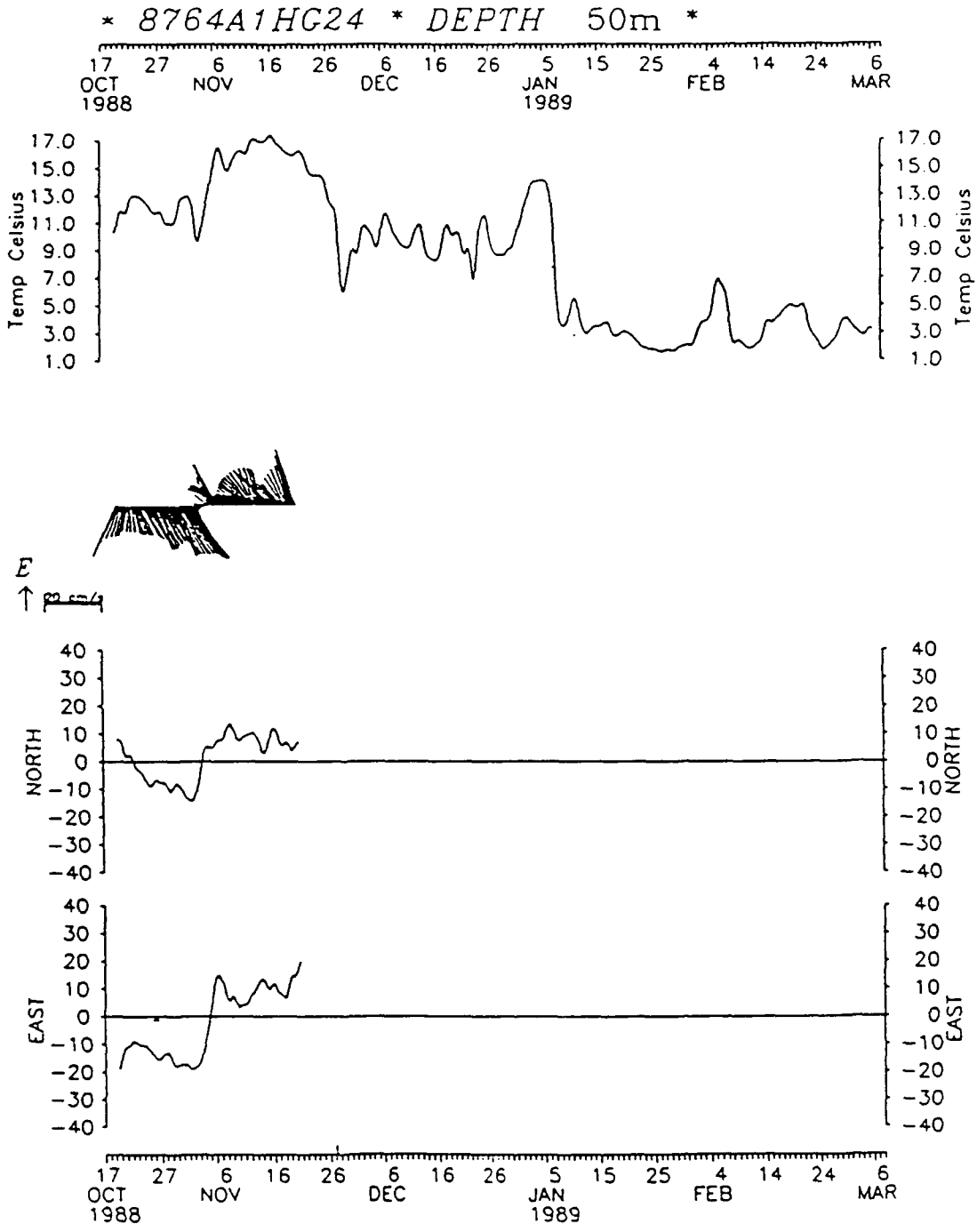
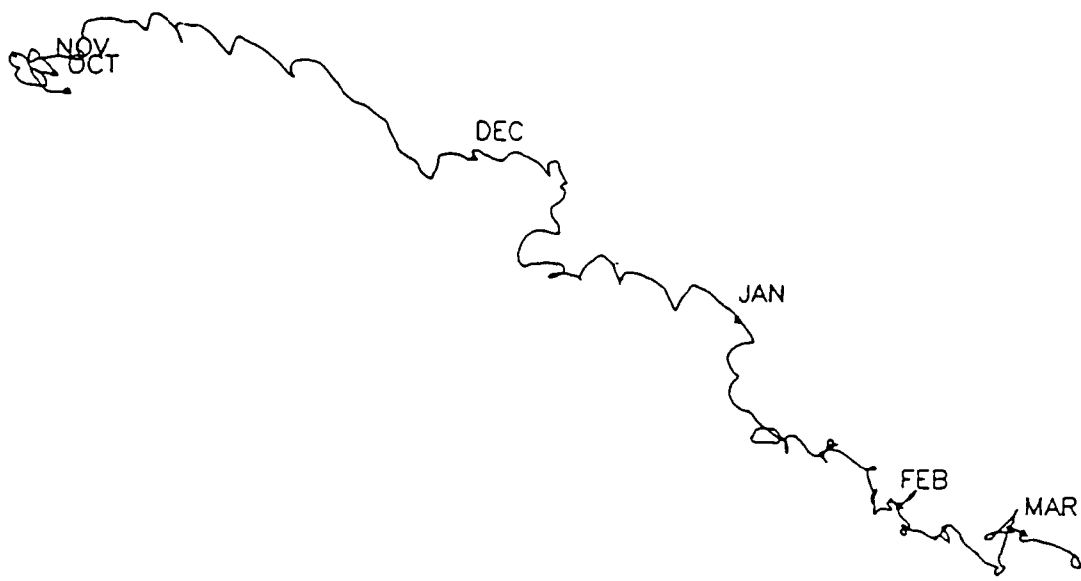

Figure 13: VM-001 time series



876S1F900  
 0 m  
 88- X -17 TO 89- III-07

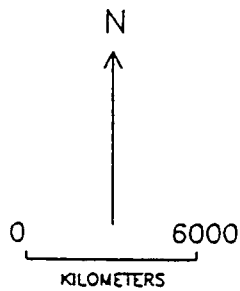
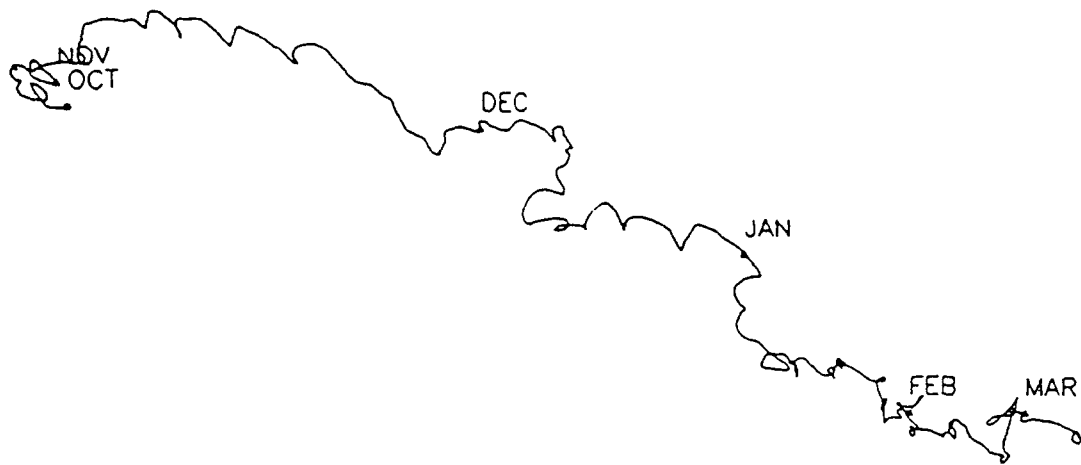

Figure 14: V-161WR progressive wind vector plot



876S2F900  
 0 m  
 88- X -17 TO 89-III-07

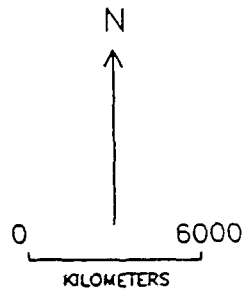
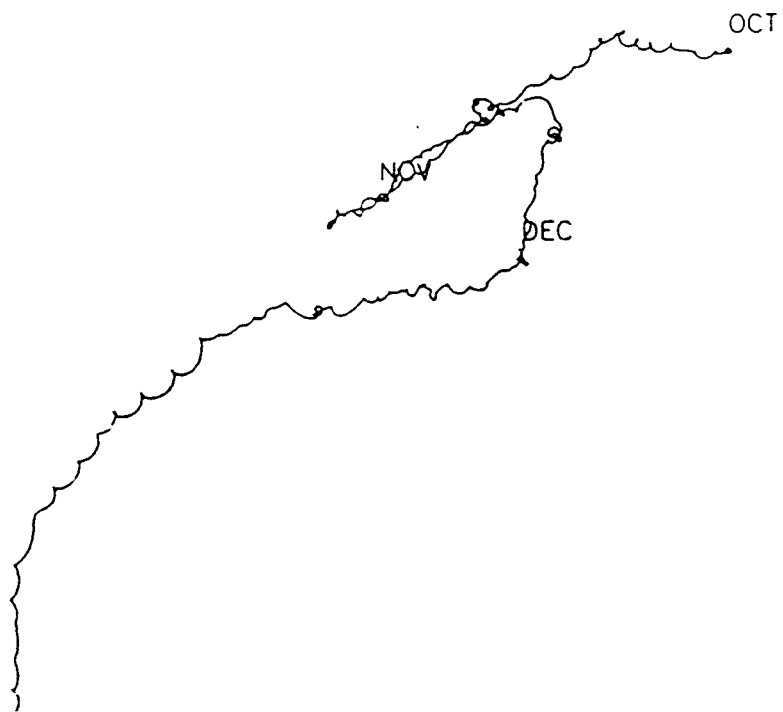

Figure 15: V-707WR progressive wind vector plot



8763A450  
20 m  
88- X -18 TO 88- XII-26

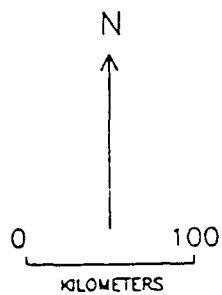
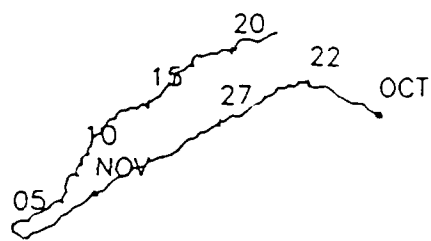

Figure 16: VM-026 progressive current vector plot



8764A450  
50 m  
88- X -18 TO 88- XI -21

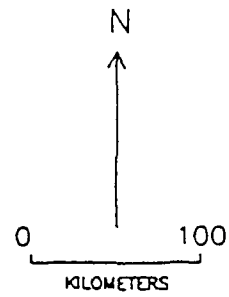
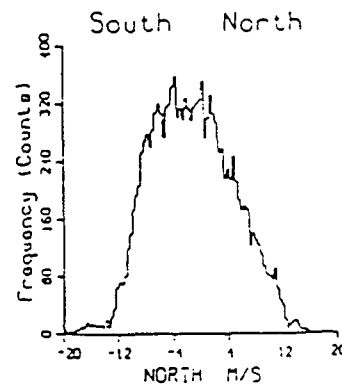
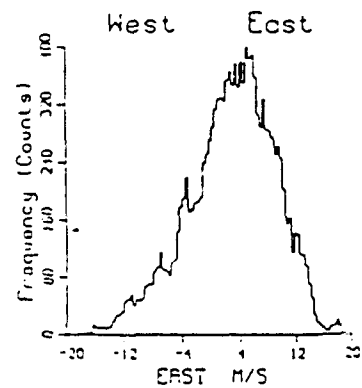
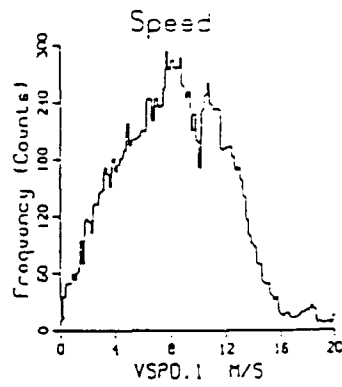
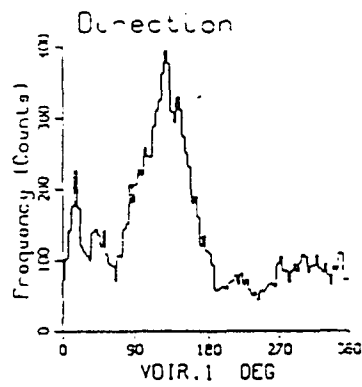
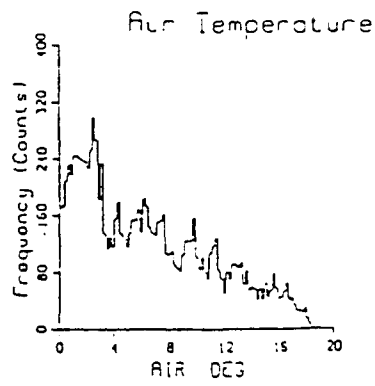
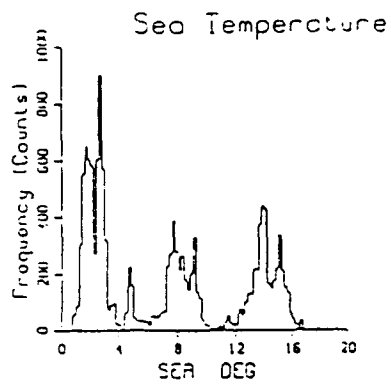
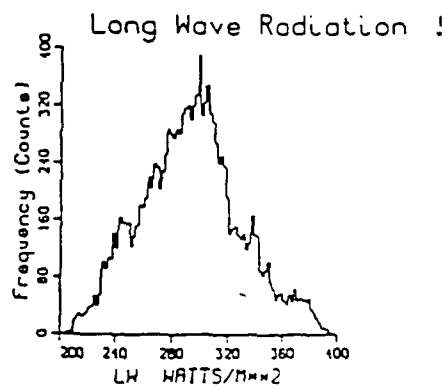
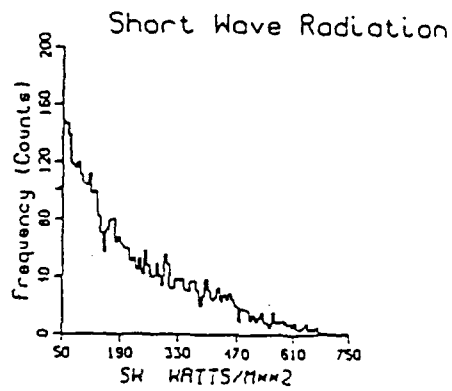
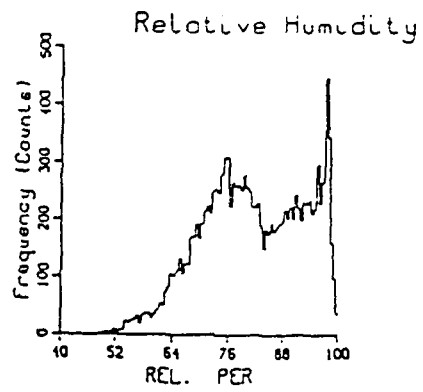
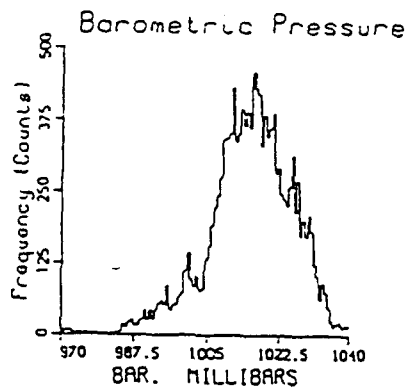

Figure 17: VM-001 progressive current vector plot



Data File 876S1F900 : Depth = 0m

Figure 18: V-161WR histograms



Data File 876S!F900 : Depth = 0m

Figure 18: Continued

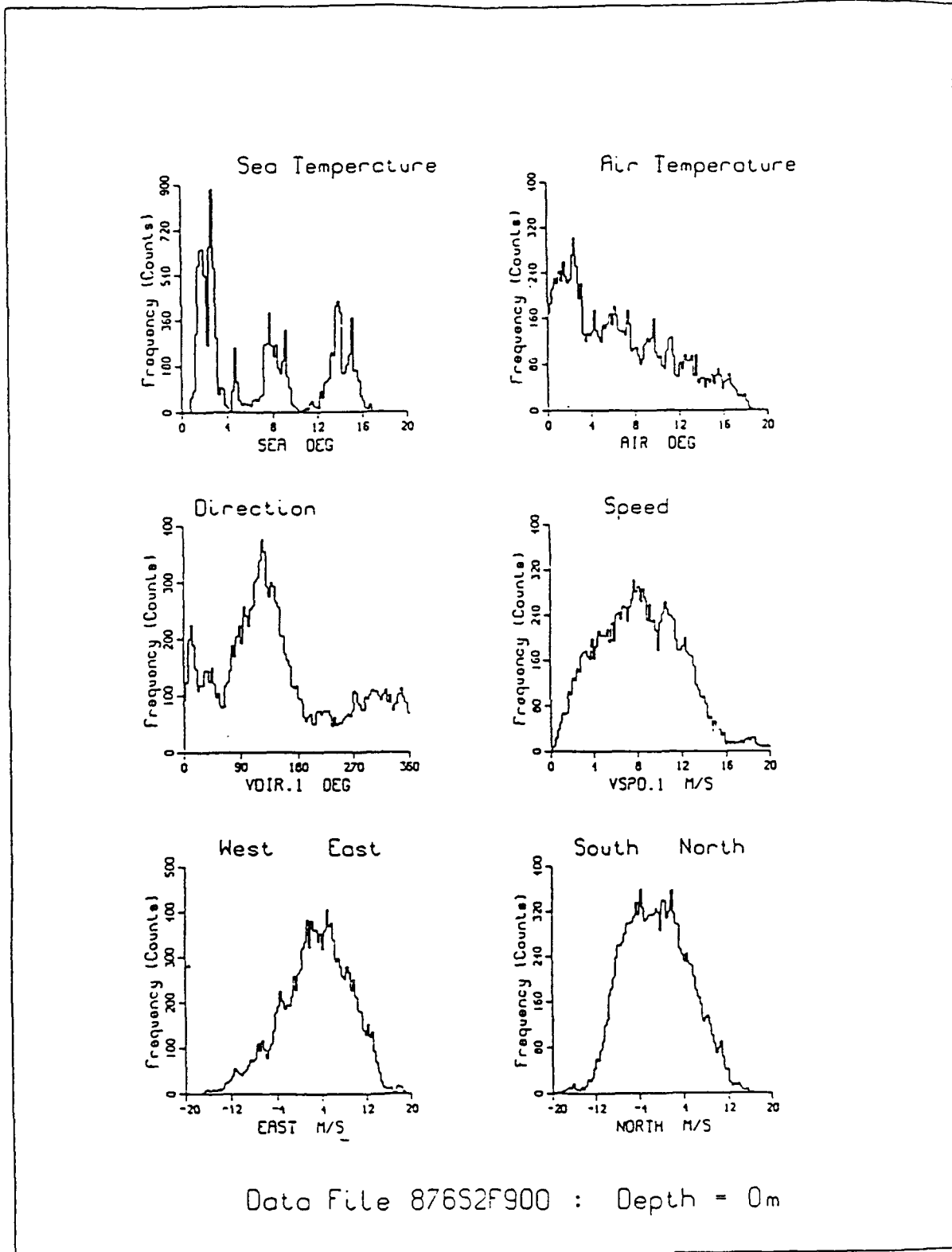

Figure 19: V-707WR histograms

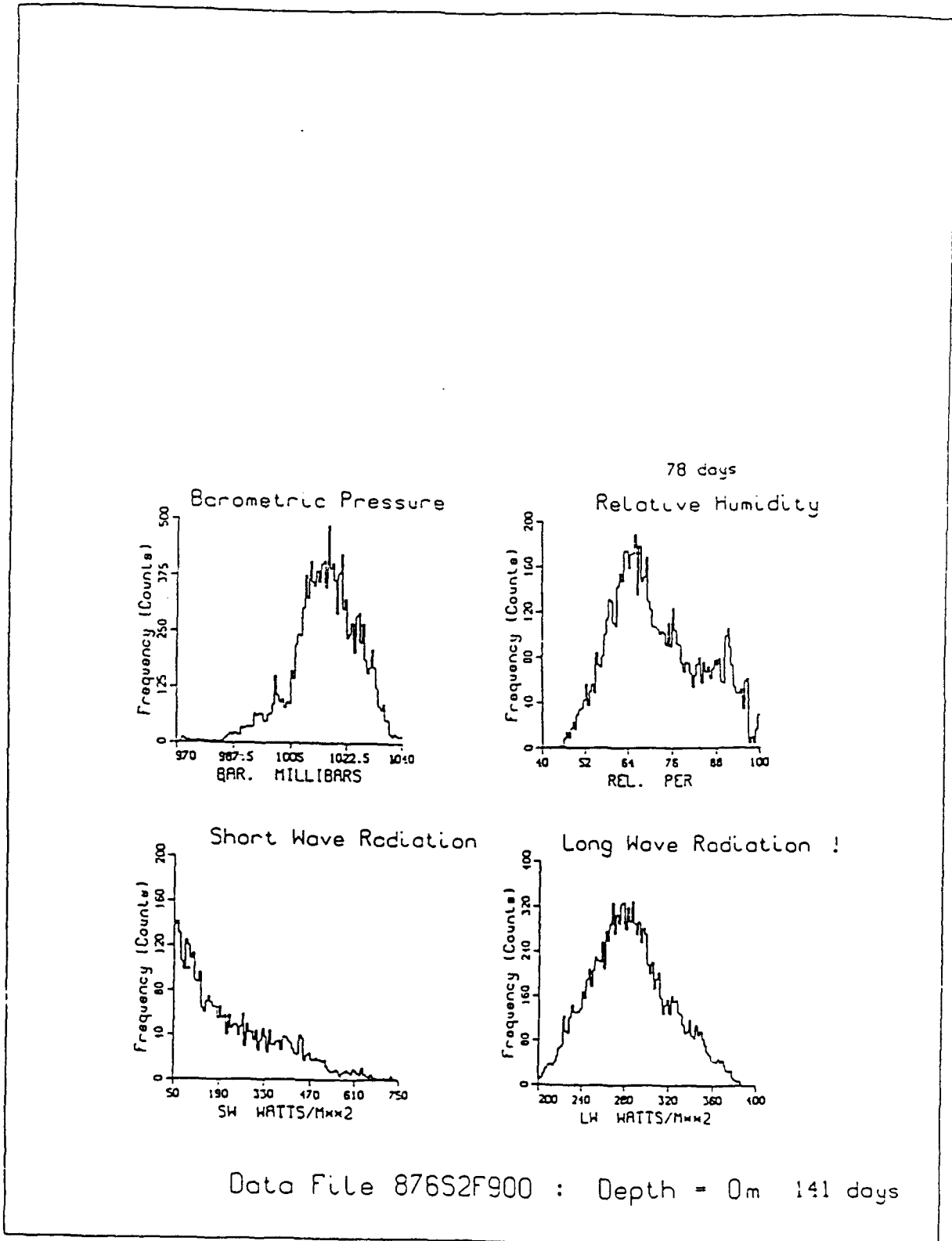

Figure 19: Continued

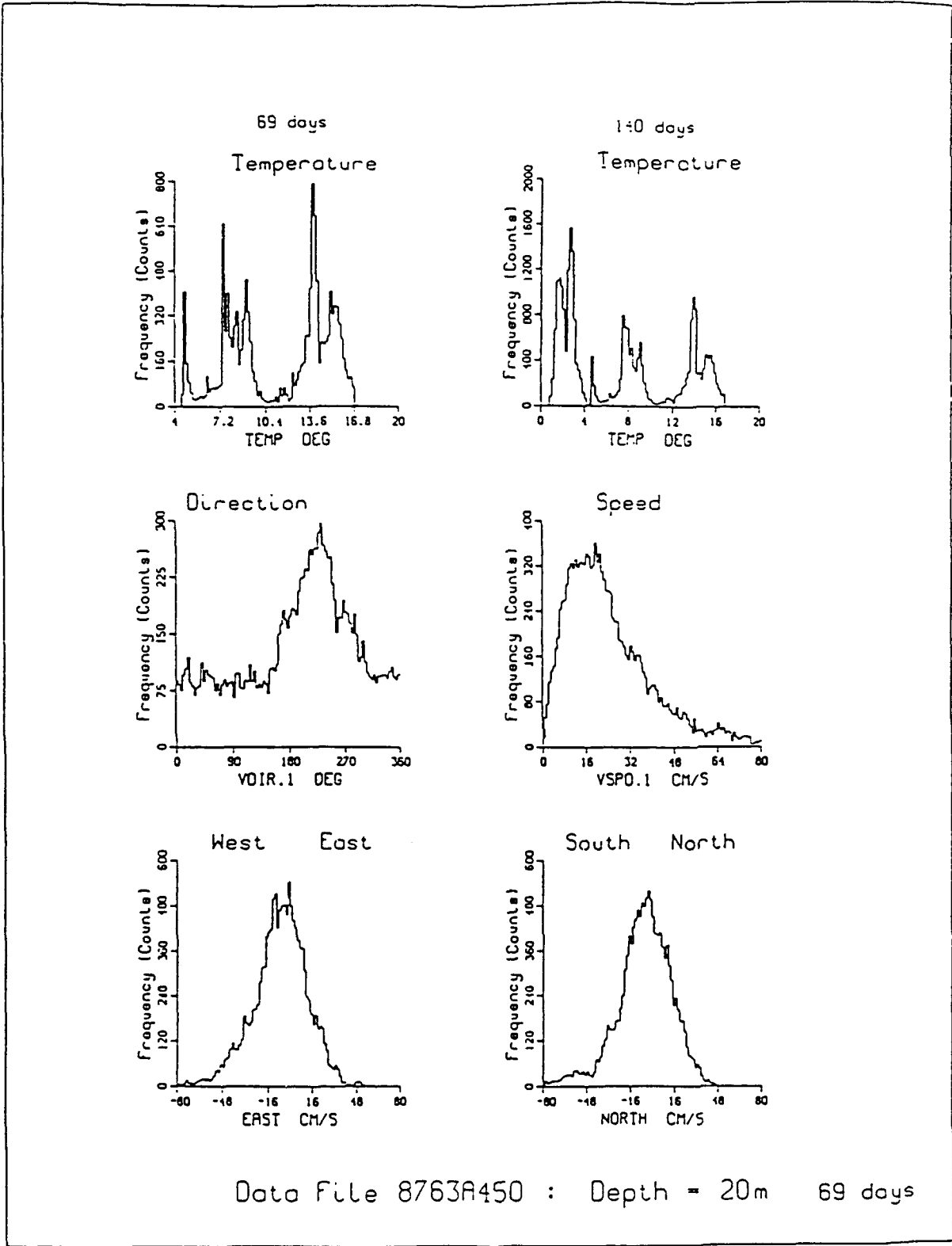

Figure 20: VM-026 histograms

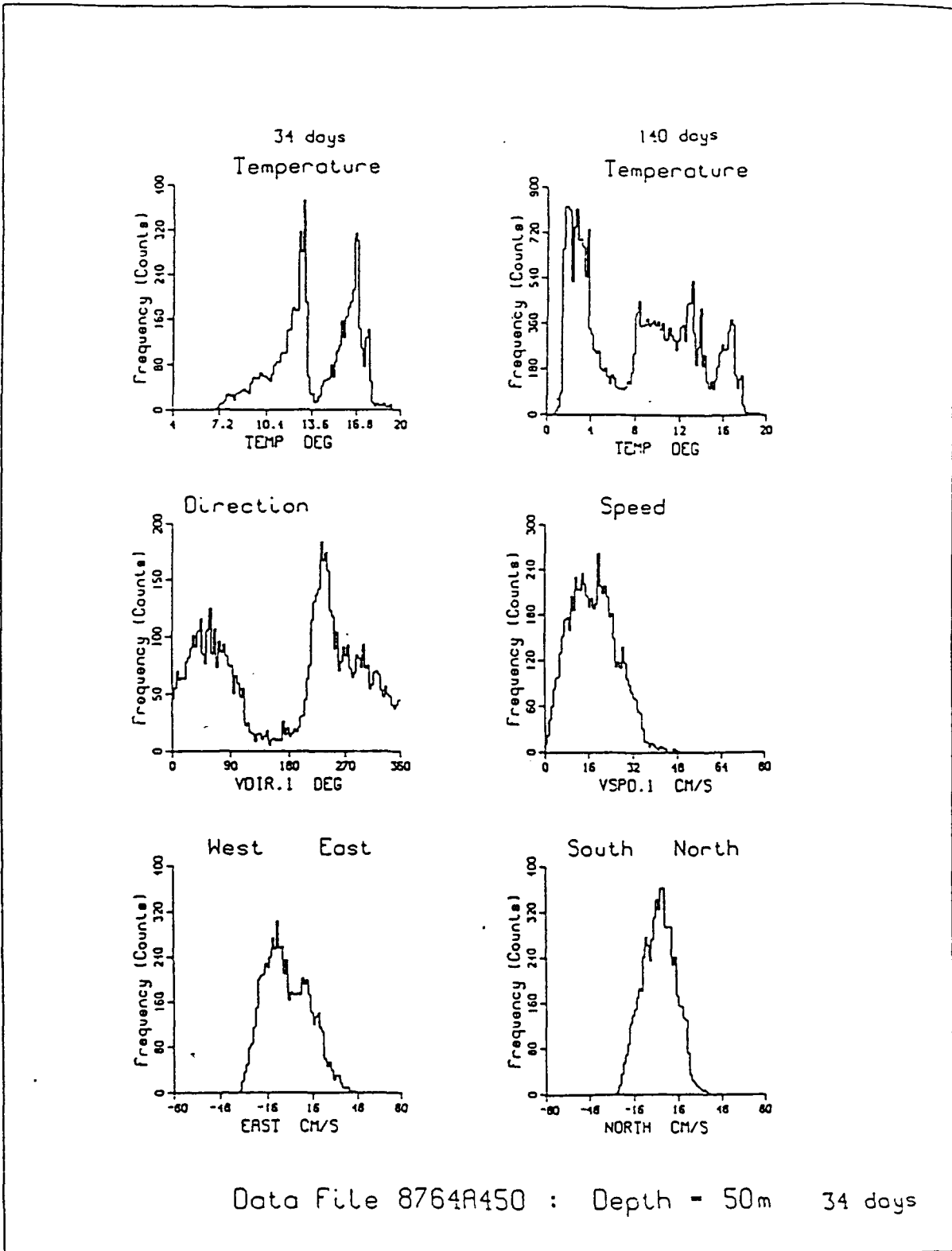
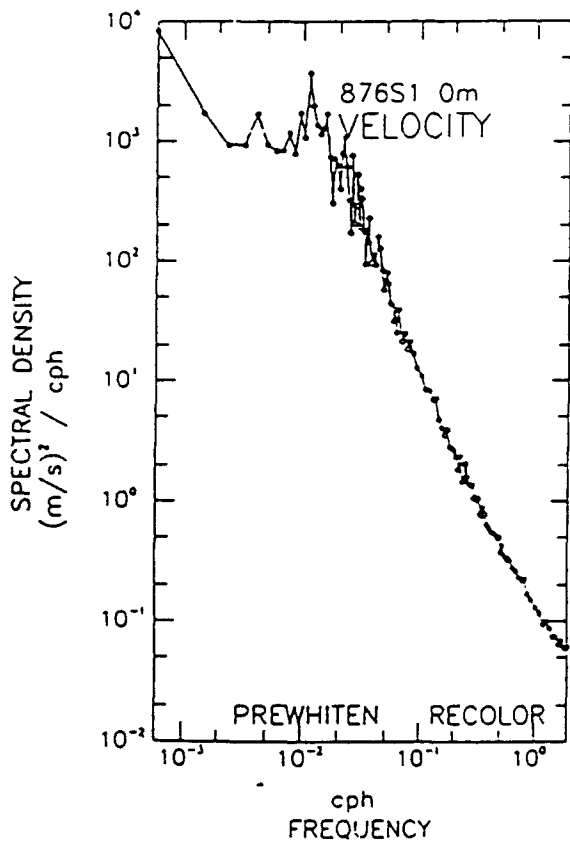
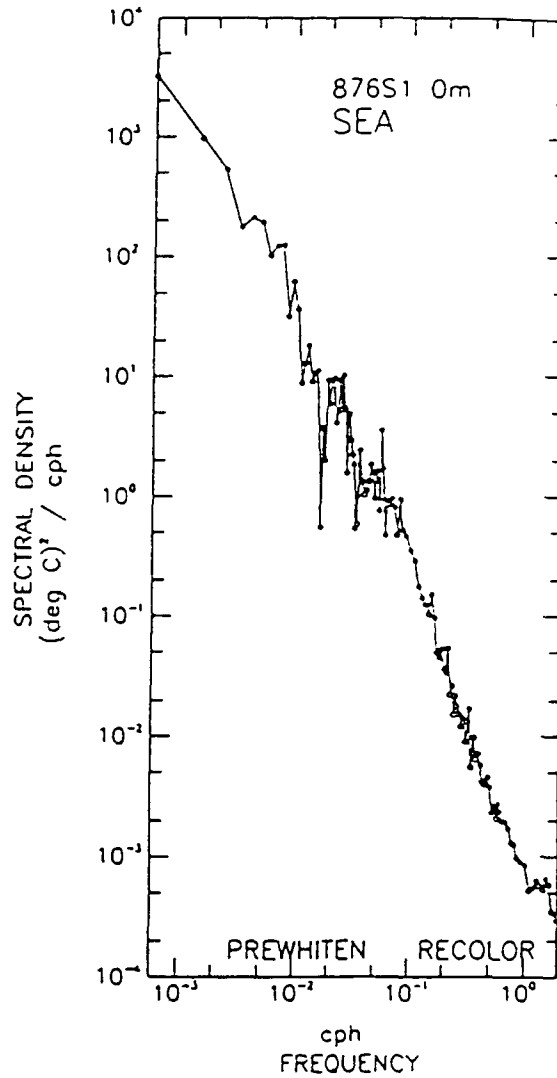

Figure 21: VM-001 histograms



NO. PIECES = 1  
PLEN = 13524



NO. PIECES = 1  
PLEN = 13524

Figure 22: V-161WR spectra

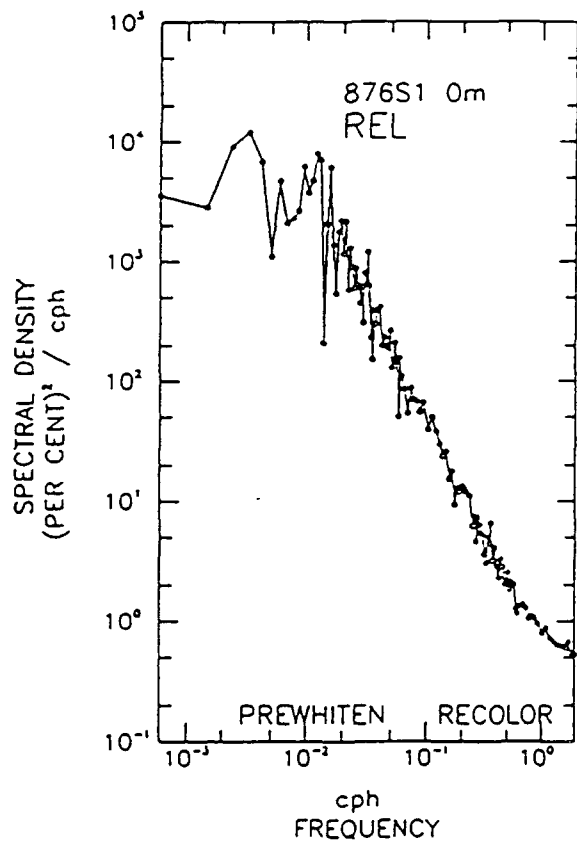

NO. PIECES = 1  
PLEN = 13524

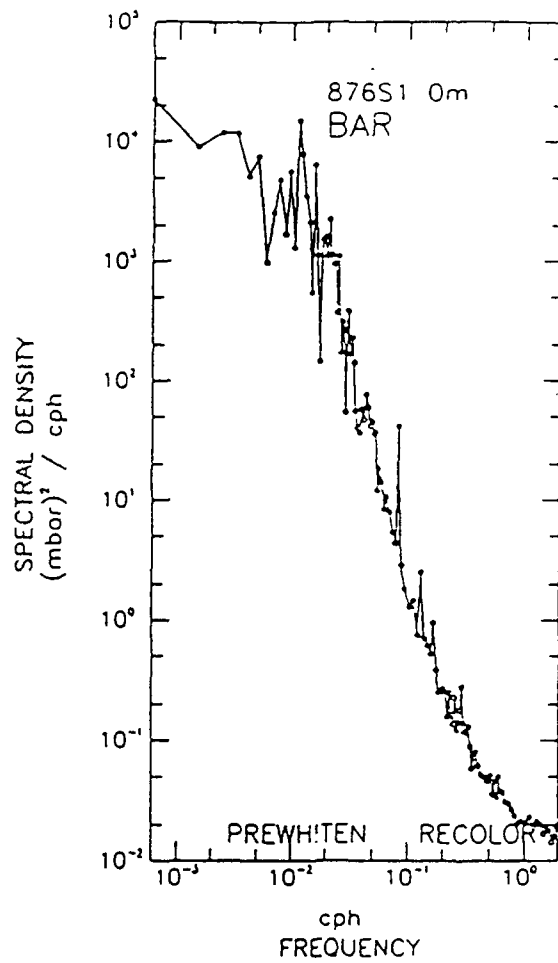

NO. PIECES = 1  
PLEN = 13524

Figure 22: Continued

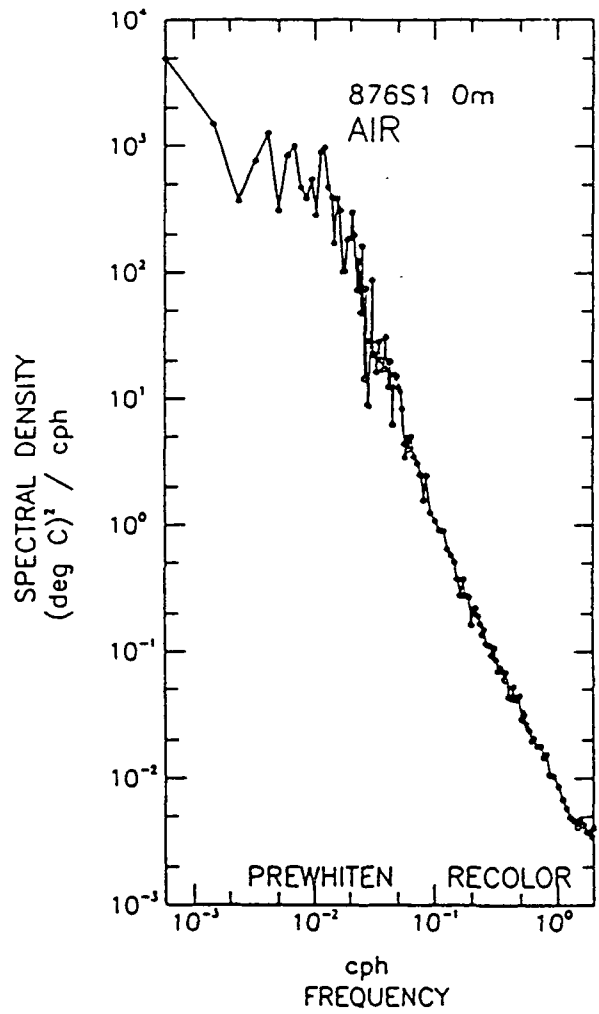

NO. PIECES = 1  
PLEN = 13524

Figure 22: Continued

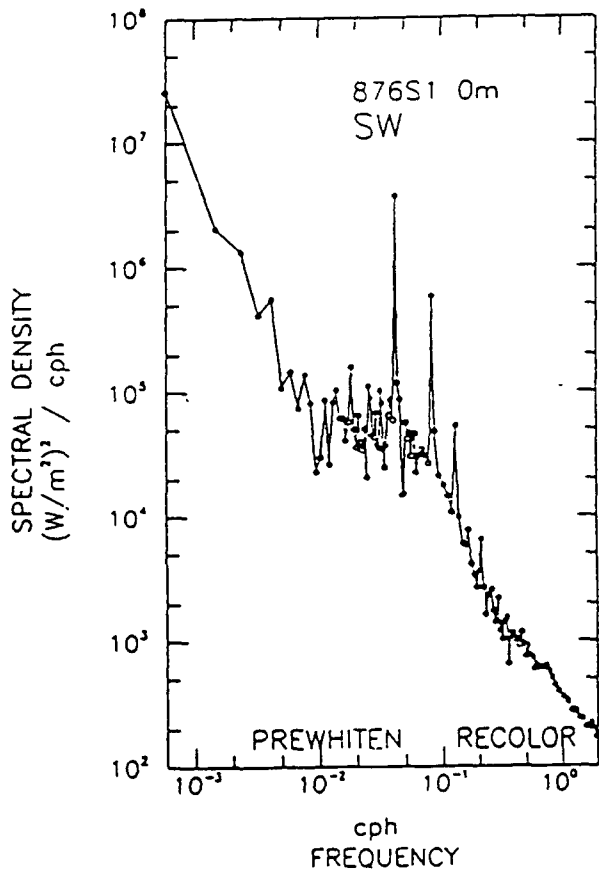

NO. PIECES = 1  
PLEN = 13524

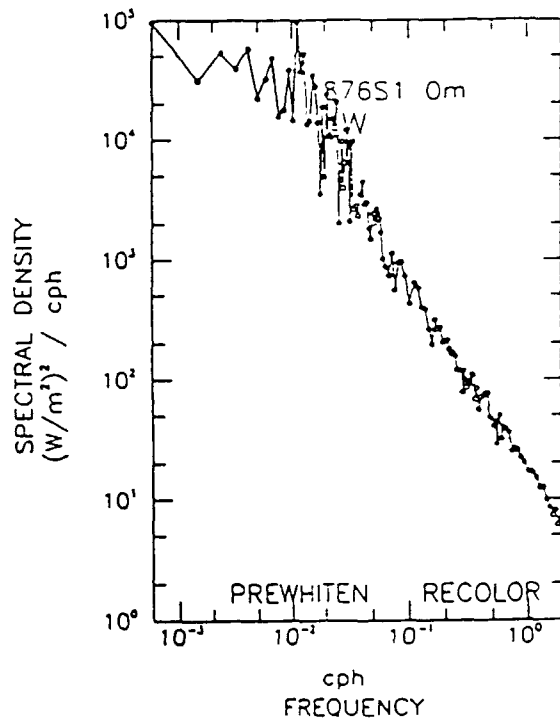

NO. PIECES = 1  
PLEN = 13524

Figure 22: Continued

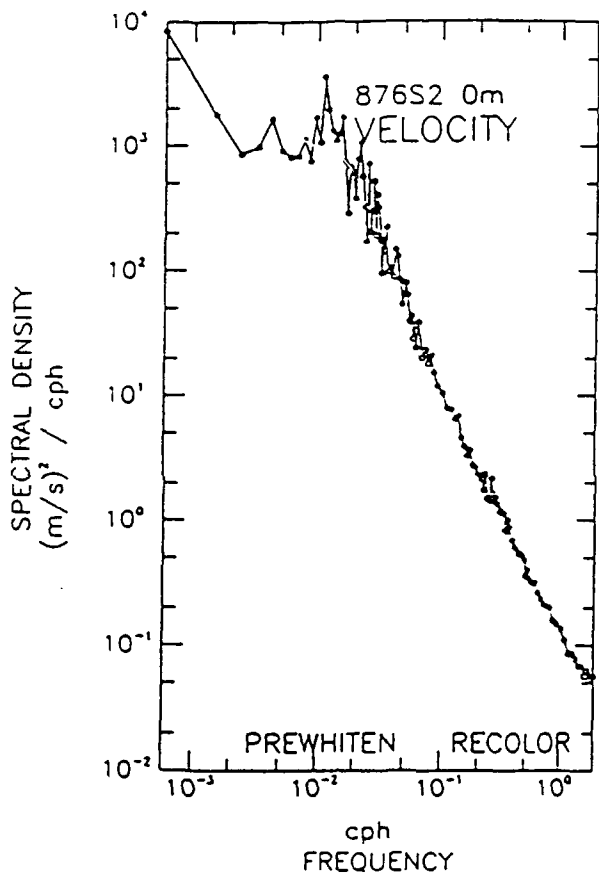

NO. PIECES = 1  
PLEN = 13524

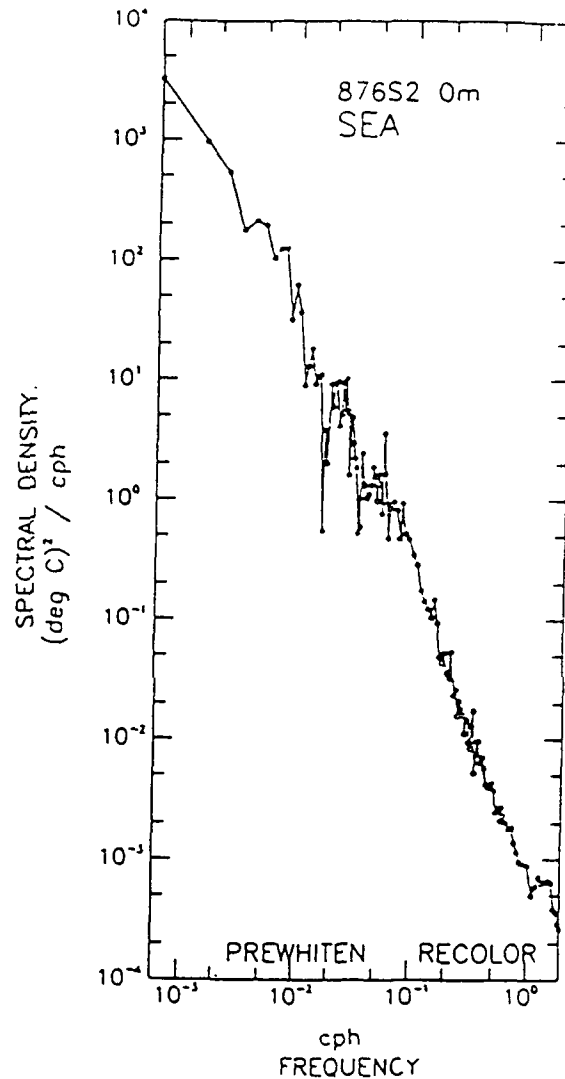

NO. PIECES = 1  
PLEN = 13524

Figure 23: V-707WR spectra

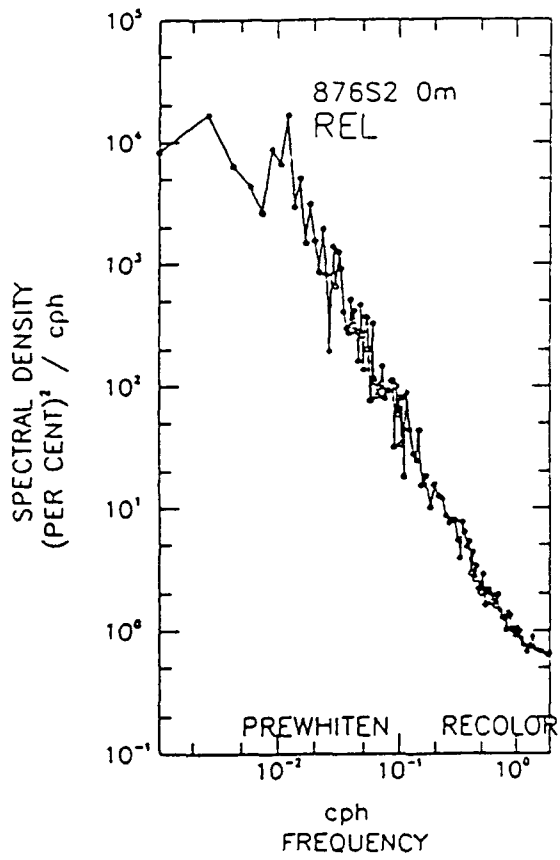

NO. PIECES = 1  
PLEN = 7514

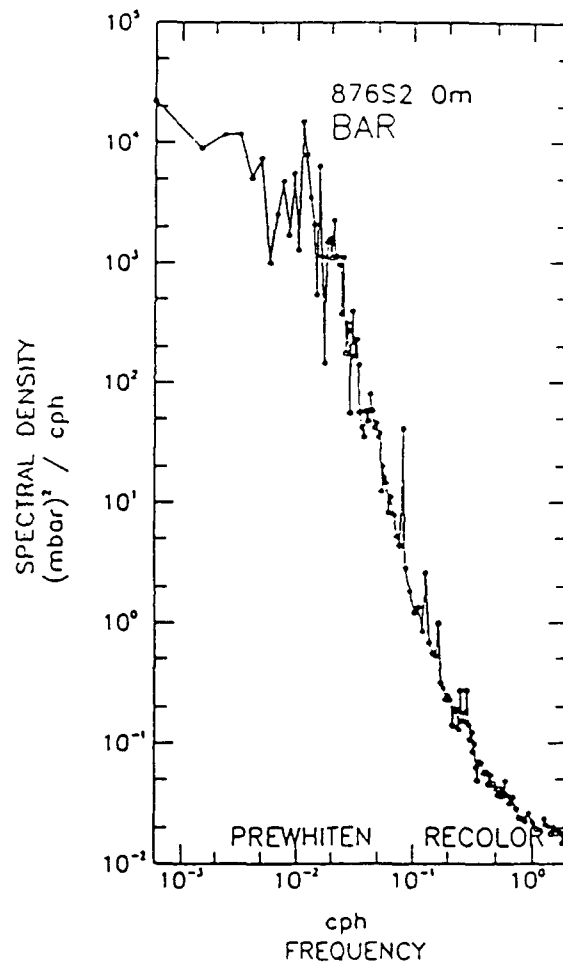

NO. PIECES = 1  
PLEN = 13524

Figure 23: Continued

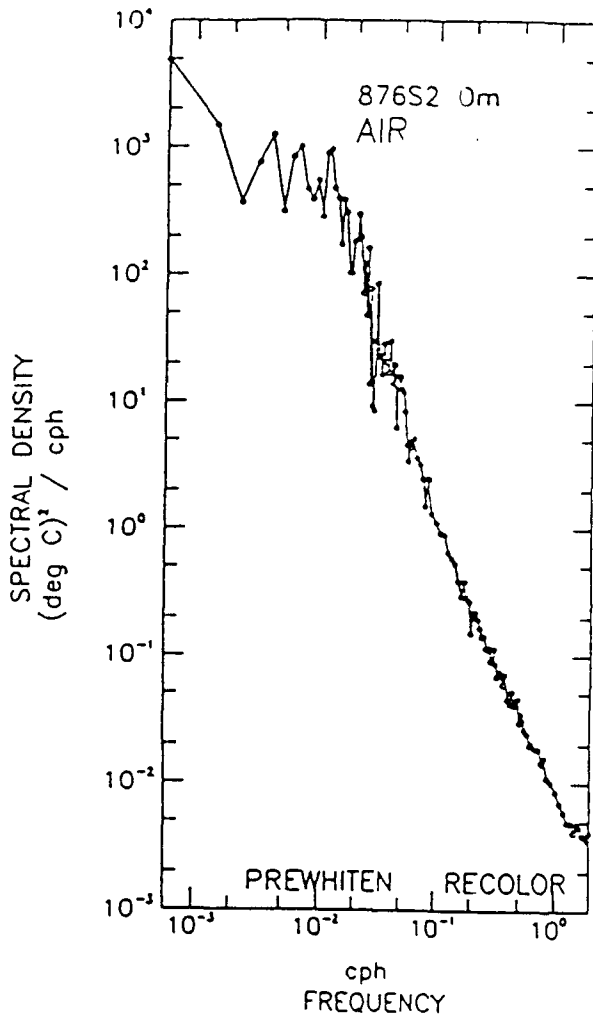

NO. PIECES = 1  
PLEN = 13524

Figure 23: Continued

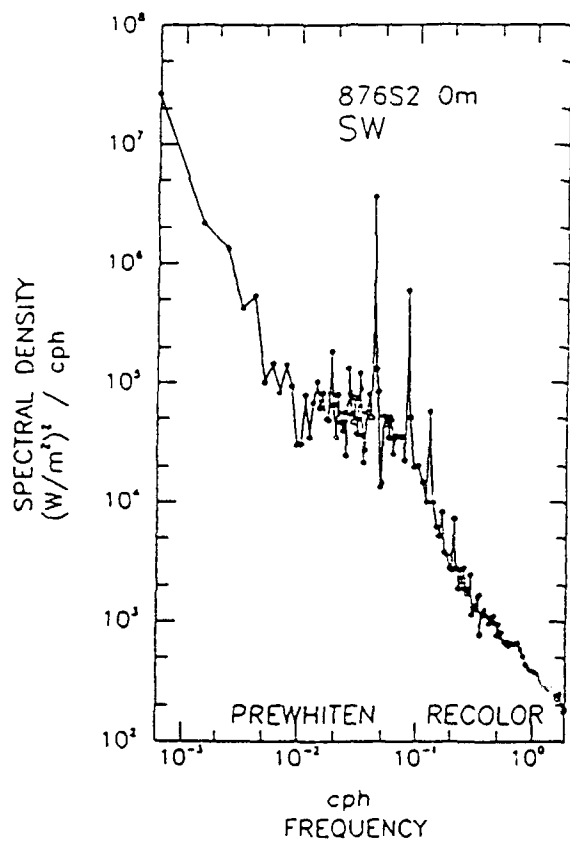

NO. PIECES = 1  
PLEN = 13524

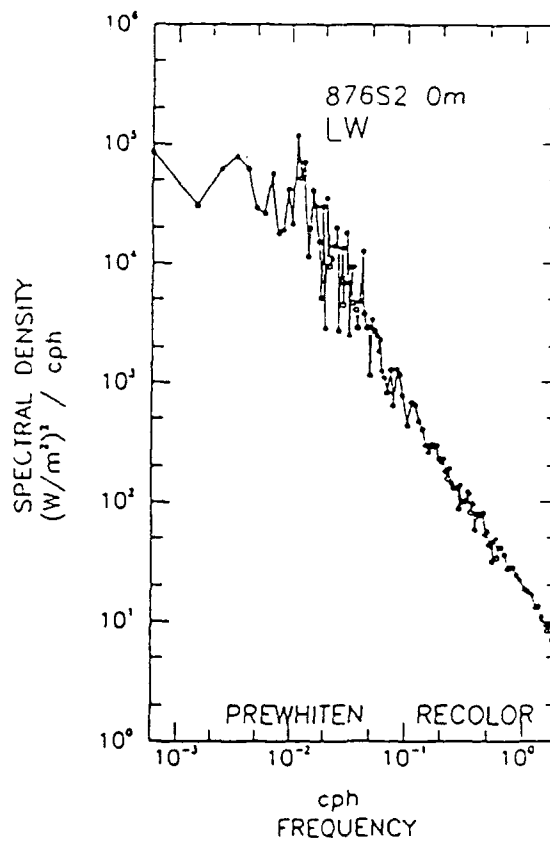

NO. PIECES = 1  
PLEN = 13524

Figure 23: Continued

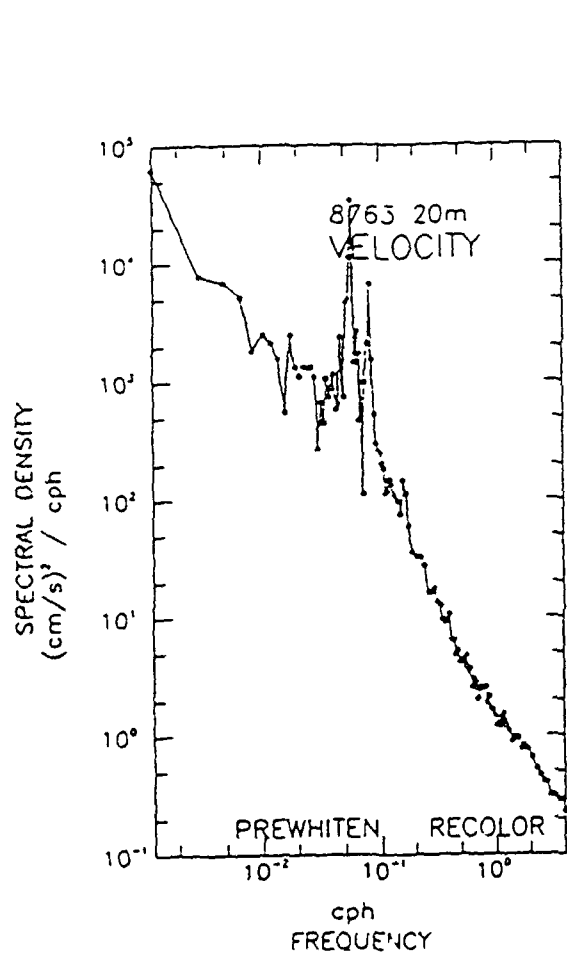

NO. PIECES = 1  
PLEN = 13294

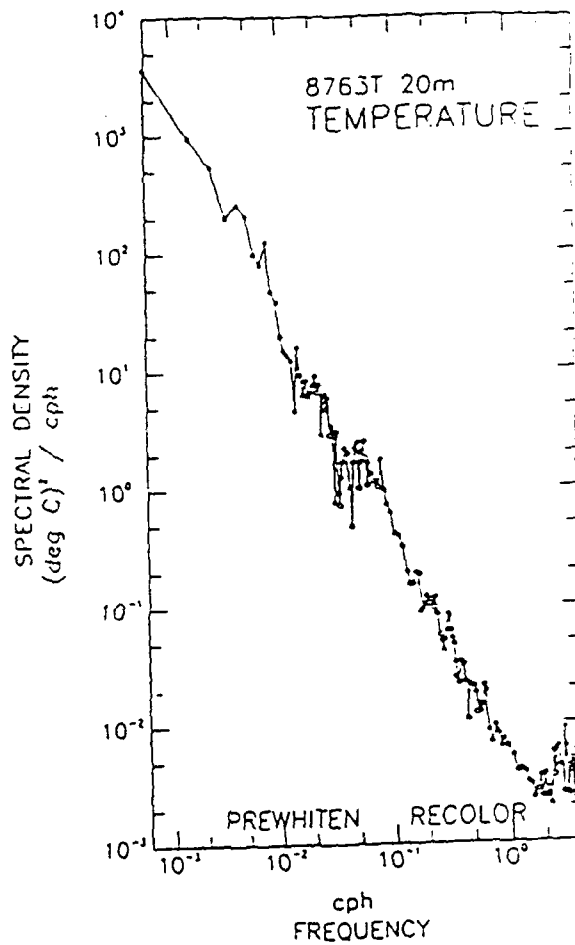

NO. PIECES = 1  
PLEN = 26880

Figure 24: VM-026 spectra

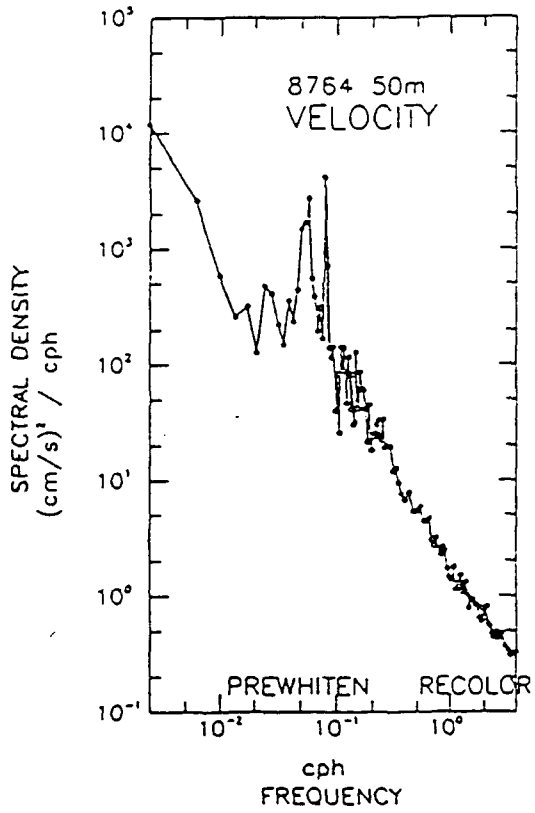

NO. PIECES = 1  
PLEN = 6534

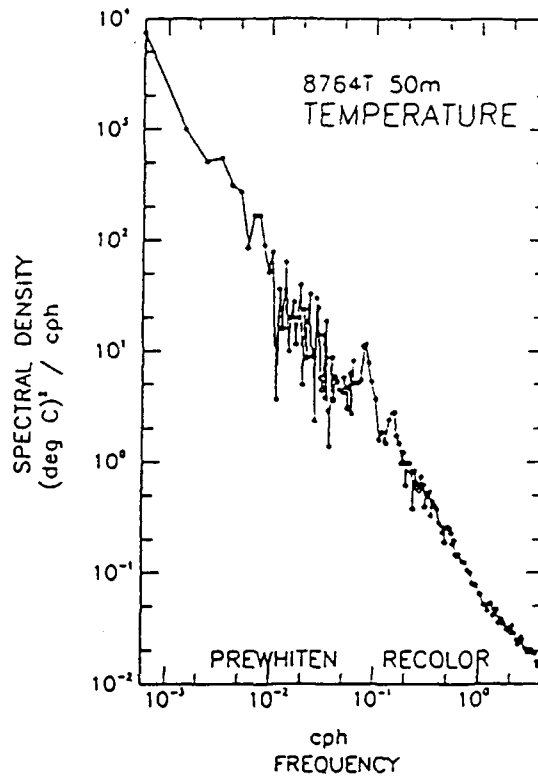

NO. PIECES = 1  
PLEN = 26880

Figure 25: VM-001 spectra

## References

- Dean, J. P., and R. C. Beardsley, 1988: A Vector-Averaging Wind Recorder (VAWR) system for surface meteorological measurements in CODE (Coastal Ocean Dynamics Experiment). Woods Hole Oceanographic Institution, *Technical Report, WHOI-88-20*, 74 pp.
- Hadlock, R., and C. W. Kreitzberg, 1988: The Experiment on Rapidly Intensifying Cyclones over the Atlantic (ERICA) field study: Objective and plans. *Bulletin of the American Meteorological Society*, **69**, 1309–1320.
- Hunt, M., 1982: A program for spectral analysis of time series "PROSPECT." WHOI Internal Document, 188 pp.
- Kery, S. M., 1989: Severe Environment Surface Mooring (SESMOOR). Oceans '89, IEEE, Seattle, Washington, pp. 1398–1405.
- Payne, R. E., 1974: A buoy-mounted meteorological recording package. Woods Hole Oceanographic Institution, *Technical Report, WHOI-74-40*, 32 pp.
- Roebber, P. J., 1984: Statistical analysis and updated climatology of explosive cyclones. *Monthly Weather Review*, **112**, 1577–1589.
- Tarbell, S. A., A. Spencer, and E. T. Montgomery, 1988: The Buoy Group data processing system. Woods Hole Oceanographic Institution, *Technical Memorandum, WHOI-3-88*.
- Weller, R. A., and R. E. Davis, 1980: A vector measuring current meter. *Deep-Sea Research*, **27A**, 565–582.
- Weller, R. A., D. L. Rudnick, R. E. Payne, J. P. Dean, N. J. Pennington, and R. P. Trask, 1990: Measuring near-surface meteorology over the ocean from an array of surface moorings in the subtropical convergence zone. *Journal of Atmospheric and Oceanic Technology*, **7**, 85–103.

## DOCUMENT LIBRARY

March 11, 1991

### *Distribution List for Technical Report Exchange*

Attn: Stella Sanchez-Wade  
Documents Section  
Scripps Institution of Oceanography  
Library, Mail Code C-075C  
La Jolla, CA 92093

Hancock Library of Biology &  
Oceanography  
Alan Hancock Laboratory  
University of Southern California  
University Park  
Los Angeles, CA 90089-0371

Gifts & Exchanges  
Library  
Bedford Institute of Oceanography  
P.O. Box 1006  
Dartmouth, NS, B2Y 4A2, CANADA

Office of the International  
Ice Patrol  
c/o Coast Guard R & D Center  
Avery Point  
Groton, CT 06340

NOAA/EDIS Miami Library Center  
4301 Rickenbacker Causeway  
Miami, FL 33149

Library  
Skidaway Institute of Oceanography  
P.O. Box 13687  
Savannah, GA 31416

Institute of Geophysics  
University of Hawaii  
Library Room 252  
2525 Correa Road  
Honolulu, HI 96822

Marine Resources Information Center  
Building E38-320  
MIT  
Cambridge, MA 02139

Library  
Lamont-Doherty Geological  
Observatory  
Columbia University  
Palisades, NY 10964

Library  
Serials Department  
Oregon State University  
Corvallis, OR 97331-5503

Pell Marine Science Library  
University of Rhode Island  
Narragansett Bay Campus  
Narragansett, RI 02882

Working Collection  
Texas A&M University  
Dept. of Oceanography  
College Station, TX 77843

Library  
Virginia Institute of Marine Science  
Gloucester Point, VA 23062

Fisheries-Oceanography Library  
151 Oceanography Teaching Bldg.  
University of Washington  
Seattle, WA 98195

Library  
R.S.M.A.S.  
University of Miami  
4600 Rickenbacker Causeway  
Miami, FL 33149

Maury Oceanographic Library  
Naval Oceanographic Office  
Stennis Space Center  
NSTL, MS 39522-5001

Marine Sciences Collection  
Mayaguez Campus Library  
University of Puerto Rico  
Mayaguez, Puerto Rico 00708

Library  
Institute of Oceanographic Sciences  
Deacon Laboratory  
Wormley, Godalming  
Surrey GU8 5UB  
UNITED KINGDOM

The Librarian  
CSIRO Marine Laboratories  
G.P.O. Box 1538  
Hobart, Tasmania  
AUSTRALIA 7001

Library  
Proudman Oceanographic Laboratory  
Bidston Observatory  
Birkenhead  
Merseyside L43 7 RA  
UNITED KINGDOM

<b>REPORT DOCUMENTATION PAGE</b>	<b>1. REPORT NO.</b> WHOI-91-18	<b>2.</b>	<b>3. Recipient's Accession No.</b>
<b>4. Title and Subtitle</b> A Compilation of Moored Current Meter Data and Wind Recorder Data from the Severe Environment Surface Mooring (SESMOOR) Volume XLIII		<b>5. Report Date</b> July 1991	
<b>7. Author(s)</b> Gennaro H. Crescenti, Susan A. Tarbell, and Robert A. Weller		<b>8. Performing Organization Rept. No.</b> WHOI-91-18	
<b>9. Performing Organization Name and Address</b>  Woods Hole Oceanographic Institution Woods Hole, Massachusetts 02543		<b>10. Project/Task/Work Unit No.</b>	
		<b>11. Contract(C) or Grant(G) No.</b> (C)N00014-84-C-0134, NR 083-400 (G)N00014-90-J-1423	
<b>12. Sponsoring Organization Name and Address</b>  Office of Naval Research		<b>13. Type of Report &amp; Period Covered</b> Technical Report	
		<b>14.</b>	
<b>15. Supplementary Notes</b> This report should be cited as: Woods Hole Oceanog. Inst. Tech. Rept., WHOI-91-18.			
<b>16. Abstract (Limit: 200 words)</b>  A Severe Environment Surface Mooring (SESMOOR) was designed to make long term meteorological and near surface oceanographic measurements in areas where harsh environmental conditions prevail. SESMOOR was deployed in the North Atlantic Ocean approximately 300 km southeast of Halifax, Nova Scotia for 141 days during the winter of 1988-89. Meteorological data were acquired from two Vector Averaging Wind Recorders (VAWR) located on top of a specially designed buoy mast and included air temperature, relative humidity, barometric pressure, wind velocity, solar and longwave radiation. Sea surface temperature was also acquired by the VAWRs. Current velocities and sea temperatures were obtained from two Vector Measuring Current Meters (VMCM) at 20 and 50 meters below the sea surface. This report discusses instrument performance, data quality, pre-and post-deployment calibrations, data telemetry, data processing procedures. This report also presents the data in a variety of displays.			
<b>17. Document Analysis a. Descriptors</b> ocean currents ocean temperature moored instruments  <b>b. Identifiers/Open-Ended Terms</b>   <b>c. COSATI Field/Group</b>			
<b>18. Availability Statement</b>  Approved for public release; distribution unlimited.		<b>19. Security Class (This Report)</b>	<b>21. No. of Pages</b> 59
		<b>20. Security Class (This Page)</b>	<b>22. Price</b>