

2

TECHNICAL REPORT GL-91-15

# GEOPHYSICAL INVESTIGATION OF THE GRASSY ISLAND CONFINED DISPOSAL AREA, DETROIT, MICHIGAN

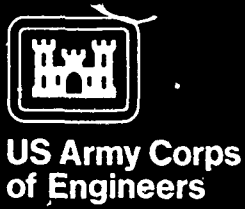

## AD-A240 809



by

Richard D. Lewis

With Contributions By: Pam Bedore, Carla Fisher, Jim Gira, Rich Sallans

Geotechnical Laboratory

DEPARTMENT OF THE ARMY

Waterways Experiment Station, Corps of Engineers

3909 Halls Ferry Road, Vicksburg, Mississippi 39180-6199

DTIC  
SELECTED  
SEP 20 1991



August 1991

Final Report

Approved For Public Release, Distribution Is Unlimited

## 91-11517



Prepared for US Army Engineer District, Detroit  
Detroit, Michigan 48231-1027

91 9 25 067

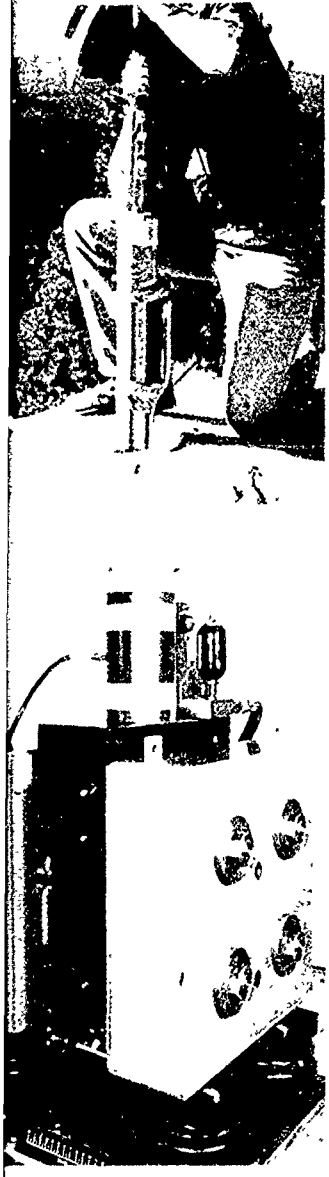

**Destroy this report when no longer needed. Do not return  
it to the originator.**

**The findings in this report are not to be construed as an official  
Department of the Army position unless so designated  
by other authorized documents.**

**The contents of this report are not to be used for  
advertising, publication, or promotional purposes.  
Citation of trade names does not constitute an  
official endorsement or approval of the use of  
such commercial products.**

# REPORT DOCUMENTATION PAGE

Form Approved  
OMB No. 0704-0188

Public reporting burden for this collection of information is estimated to average 1 hour per response, including the time for reviewing instructions, searching existing data sources, gathering and maintaining the data needed, and completing and reviewing the collection of information. Send comments regarding this burden estimate or any other aspect of this collection of information, including suggestions for reducing this burden, to Washington Headquarters Services, Directorate for Information Operations and Reports, 1215 Jefferson Davis Highway, Suite 1204, Arlington, VA 22202-4302 and to the Office of Management and Budget, Paperwork Reduction Project (0704-0188), Washington, DC 20503.

<b>1. AGENCY USE ONLY (Leave blank)</b>		<b>2. REPORT DATE</b> August 1991	<b>3. REPORT TYPE AND DATES COVERED</b> Final Report	
<b>4. TITLE AND SUBTITLE</b> Geophysical Investigation of the Grassy Island Confined Disposal Area, Detroit, Michigan			<b>5. FUNDING NUMBERS</b> IAO CENCE-IA-90-0026	
<b>6. AUTHOR(S)</b> Richard D. Lewis with contributions by: Pam Bedore, Carla Fisher, Jim Gira, Rich Sallans				
<b>7. PERFORMING ORGANIZATION NAME(S) AND ADDRESS(ES)</b> USAE Waterways Experiment Station, Geotechnical Laboratory 3909 Halls Ferry Road, Vicksburg, MS 39180-6199			<b>8. PERFORMING ORGANIZATION REPORT NUMBER</b> Technical Report GL-91-15	
<b>9. SPONSORING/MONITORING AGENCY NAME(S) AND ADDRESS(ES)</b> US Army Engineer District, Detroit Detroit, MI 48231-1027			<b>10. SPONSORING/MONITORING AGENCY REPORT NUMBER</b>	
<b>11. SUPPLEMENTARY NOTES</b> Available from National Technical Information Service, 5285 Port Royal Road, Springfield, VA 22161.				
<b>12a. DISTRIBUTION/AVAILABILITY STATEMENT</b> Approved for public release; distribution is unlimited			<b>12b. DISTRIBUTION CODE</b>	
<b>13. ABSTRACT (Maximum 200 words)</b>  <p>Geophysical surveys were conducted on a portion of the Grassy Island Confined Disposal Facility, near Detroit, Michigan, in an effort to relocate approximately 20 buried paint canisters. These containers were disposed on Grassy Island Confined Disposal Facility over 20 years ago when the location was actively used as a disposal site for dredged material. Four separate geophysical field surveys were conducted using two different geophysical methods, magnetics, and electromagnetics. These four surveys were (a) magnetic total field, (b) vertical gradient of the total magnetic field, (c) electromagnetic vertical dipole, and (d) electromagnetic horizontal dipole. Three of the four geophysical surveys which were performed detected the presence of a concentration of ferrous material in the subsurface. Positive electrical conductivity and magnetic anomaly was found at a depth of approximately 70 ft near the indicated place believed to be the paint canisters' burial area. This locale is believed to represent the best area for further investigations to relocate the targeted canisters.</p>				
<b>14. SUBJECT TERMS</b> Confined Dredged Material Disposal Facility Electromagnetics			<b>15. NUMBER OF PAGES</b> 52	
			<b>16. PRICE CODE</b>	
<b>17. SECURITY CLASSIFICATION OF REPORT</b> UNCLASSIFIED		<b>18. SECURITY CLASSIFICATION OF THIS PAGE</b> UNCLASSIFIED	<b>19. SECURITY CLASSIFICATION OF ABSTRACT</b> UNCLASSIFIED	<b>20. LIMITATION OF ABSTRACT</b>

Preface

A geophysical investigation of a portion of the Grassy Island dredge disposal site was authorized by the US Army Engineer District, Detroit (CENCE), under IAO CENCE-IA-90-0026. The work was performed during the period April to June 1990 and the field investigation was conducted during 17-21 April 1990.

Data were collected in the field by Dr. Richard D. Lewis, Engineering Geophysics Branch (EGB), Earthquake Engineering and Geosciences Division (EEGD), Geotechnical Laboratory (GL), US Army Engineer Waterways Experiment Station (WES). Ms. Pam Bedore (CENCE) was project manager for the work. Ms. Carla Fisher, Messrs. Jim Gira, Ed Lindgren, Don Sabel, and Rich Sallans (CENCE) provided field support on site. Mr. William Megehee assisted in preparation of the figures. This work was performed under the general supervision of Mr. Joseph K. Curro, Chief, EGB, Dr. Arley G. Franklin, Chief, EEGD, and Dr. William F. Marcuson III, Chief, GL.

COL Larry B. Fulton, EN, is Commander and Director of WES. Dr. Robert W. Whalin is Technical Director.



Accession For	
ADP GR&I	<input checked="" type="checkbox"/>
DTIC Pub	<input type="checkbox"/>
Unannounced	<input type="checkbox"/>
Justification	
By	
Distribution	
Availability	
Date	
A-1	

## Contents

	<u>Page</u>
Preface.....	1
Conversion Factors, Non-SI to SI (Metric)	
Units of Measurements.....	3
Summary.....	4
Background.....	6
Geophysical Surveys.....	8
Geophysical Equipment and Field Procedures.....	9
Electromagnetic Horizontal Dipole Surveys I and II.....	11
Electromagnetic Vertical Dipole Survey.....	12
Vertical Magnetic Gradient Survey.....	13
Total Magnetic Field Survey.....	14
Conclusions.....	14
Recommendations.....	16
Table 1	
Figures 1-30	

Conversion Factors, Non-SI to SI (Metric)  
Units of Measurement

Non-SI units of measurement used in this report can be converted to SI (metric) units as follows:

<u>Multiply</u>	<u>By</u>	<u>To Obtain</u>
degrees (angle)	0.01745329	radians
feet	0.3048	metres
miles (US statute)	1.609347	kilometers

GEOPHYSICAL INVESTIGATION OF THE GRASSY ISLAND  
CONFINED DISPOSAL AREA, DETROIT, MICHIGAN

Summary

1. Magnetic and electromagnetic (EM) geophysical investigations were conducted to determine the presence and location of approximately 20 5-gal paint drums which were buried about 20 years ago on Grassy Island Confined Disposal Facility (CDF). Magnetic and electromagnetic investigations were conducted to determine the if the presence and location of the drums could be determined. Four different geophysical field surveys were conducted using the two different geophysical methods, magnetic and EM. These four surveys were: (1) Magnetic total field. (2) Vertical gradient of the total magnetic field. (3) Electromagnetic vertical dipole. (4) Electromagnetic horizontal dipole. The electromagnetic technique measures the subsurface electrical conductivity by induction methods. The two different electromagnetic surveys were performed using different electromagnetic coil transmitter-reciever configurations. Each arrangement had a different depth of penetration or investigation. One of these EM surveys was repeated to provide quality control. This duplicated effort demonstrated the repeatability of the electromagnetic measurements, as the repeated surveys produced nearly identical results. Three of the four geophysical surveys which were performed detected the presence of a concentration of ferrous material in the subsurface. A total of three areas were located which had a high concentration of ferrous substances in the subsurface. Each area was identified on at least three of the four different geophysical surveys. One of these concentrations of ferrous material was approximately at the depth and location where the paint drums were believed to be buried. This site is

believed to represent the best area for further investigations to locate the targeted cannisters.

2. The geophysically surveyed part of Grassy Island CDF was approximately 500 X 75 feet in dimension. It encompassed the area where based upon historical recollections of CENCE personnel the cannisters were believed to be buried. A positive electrical conductivity and magnetic anomaly was found near (approximately 70 feet) the indicated place which was believed to be the paint cannisters' burial area. This location also produced geophysical anomalies which displayed signatures that would be expected for a ferrous material concentration of the anticipated number and burial depth of the paint cannisters. In addition, two other bodies of ferrous metal substance were detected in the subsurface in the study area. One is probably too large in ferrous mass to be the cannisters of interest and the other is most likely located south of the indicated burial area to be the desired target.

3. The areas where significant concentrations of ferrous metal are indicated in the subsurface may actually be concentrations of taconite (iron ore) pellets. A portion of the dredged area from which Grassy Island CDF was constructed originated from the Federal Channel which was utilized by large iron ore cargo ships. Material which was spilled from the unloading and hauling operations could have been deposited in the dredged channels. Local high concentrations of the taconite pellets (or other ores of iron) could have been formed during the dredge disposal at the end orifice of the hydraulic line. Since the taconite pellets have a high specific gravity, they would be deposited very close to the outlet end of the disposal pipeline, rather than be dispersed over a larger area. In this manner a rather local and high concentration of ferrous material could have been formed.

## Background

4. The Grassy Island Confined Disposal Facility CDF is an artificially constructed island on the Detroit River which was used as a dredged sediment disposal area, Figure 1. The island is approximately 3,500 feet long and 1000 feet wide. It is situated approximately 1/2 mile east of the public waterfront park of the City of Ecorse, Michigan. The island is situated between the Trenton and Fighting Island channels and was used as a material disposal site for the material from the Rouge River Federal Navigation Project. A temporary monument situated at approximately Lat 42° 12' 25" Long 83° 08' 12" was used as a reference point for the initial ground surveys on the island. This CDF is no longer used for dredge disposal and it is presently under consideration by the US Fish and Wildlife Service for use as a wildlife refuge.

5. Electromagnetic and magnetic geophysical surveys were conducted from 17 to 21 APR 1990 on the southwest portion of Grassy Island CDF near Detroit, Michigan for the US Army Engineer District, Detroit (CENCE). The purpose of these surveys was to locate approximately twenty 5 gal heavy-duty paint cans that were buried during the approximate period 1969 to 1972 on the island. The approximate area where the cans may be buried was indicated by Mr. Bill Packer of CENCE, a crane operator who excavated the hole for the placement of the material. The paint cans contained a US Air Force blue color paint which was surplused to the US Army Engineer District, Detroit. After several years of storage at the Detroit Area Office, the paint was disposed on Grassy Island CDF. Since the time of burial, the island has been extensively used for dredge material disposal and the cans are believed to be covered by approximately 20 to 24 feet of dredged material. Details concerning the paint cans are not documented, but CENCE provided all information obtainable concerning the history and location of the material.

6. Access to Grassy Island CDF was provided by a survey/dive boat from the Detroit area office located at Ft. Wayne. The weather was generally warm, with showers delaying the study approximately 1/2 day. Grassy Island CDF is approximately 25 feet above the river level and is surrounded by a retention dike. The surface is flat with a tall vegetative stand of the reed-like grass Phragmites, a.k.a. Ditch Reed. The vegetative cover in the area to be geophysically surveyed had been pushed over by a small bulldozer, which greatly aided accessibility for the investigation. Survey lines were established from a monument on the Grassy Island CDF dike designated 0 Northing and 0 Easting. The position of the monument based on the best estimate of the location from maps produced by the US Geological Survey is estimated to be situated at approximately Lat  $42^{\circ} 12' 25''$  Long  $83^{\circ} 08' 12''$ . A grid was established for the geophysical investigation. A "North-South" baseline was laid on top of the dike on the western side of Grassy Island CDF. This baseline was actually oriented about  $44^{\circ}$  East of magnetic north and  $39^{\circ}$  East of grid north. North-South traverses were placed every 12.5 feet and data points were surveyed every 10 feet along each traverse. A reference stake was placed every 50 feet apart along the survey traverses. Three hand augered holes were located in the study area. Two holes bored to investigate the subsurface conditions down to 25 feet were located at (349 Northing, 34 Easting and 368 Northing, 18 Easting) in this coordinate system. A third hole was bored in the general area of the other two auger holes but it could not be relocated.

## Geophysical Surveys

7. Several geophysical surveys were conducted on Grassy Island CDF. Each of these surveys were capable of locating concentrations of ferrous metal buried in the subsurface. Two types of geophysical surveys were conducted: (1) Magnetic. (2) Electromagnetic induction. The magnetic methods measure disturbances in the Earth's magnetic field due to near-by ferrous metals. For the Grassy Island CDF both the spatial variation in the Earth's total magnetic field (TMF) strength and changes in the Earth's vertical magnetic field gradient (VMFG) were examined. Generally, the TMF method is better in the location of larger but deeper concentrations of ferrous substances, while the VMFG method has more favorable results with smaller but shallower ferrous targets. However at the Grassy Island CDF both techniques worked equally well. The electromagnetic induction techniques measure electrical conductivity changes near or between transmitter and receiving coils. By changing the separation distance between the two coils or the geometry of the two coils (e.g. dipolar or planer) electrical conductors at different depths in the subsurface can be located. Two different coil geometries were used at the Grassy Island CDF. Each geometry has a different zone of influence in the subsurface. The use of the two different geophysical methods is based upon a tandem approach for the investigation. The EM method investigates subsurface material with a high electrical conductance. Although most metals have high electrical conductances, so do some clays. The magnetic method is based upon secondary magnetic field disturbances from ferrous metals or minerals in the subsurface. In the area of Grassy Island there should only be a very low concentration of naturally occurring ferrous minerals in the subsurface. Thus, ferrous metal object(s) in the near subsurface at Grassy Island should have both an EM and a magnetic response.

## Geophysical Equipment and Field Procedures

8. The geophysical equipment used in this investigation for the magnetic survey was a Model OMNI 4, EDA Magnetometer, serial number C059. The magnetometer is a dual-sensor, proton precession unit which measures the total magnetic field in nano Teslas. The two sensors are vertically separated by 0.5 meter. This feature allowed both the total magnetic field and the vertical gradient of the total magnetic field to be measured. A magnetic reference base was established at location 0' Northing and 0' Easting during the field operation. All measurement locations were referenced to this base station. This reference station was reoccupied every 30 to 45 minutes to allow compensation of the gradual diurnal variation of the earth's magnetic field during the day. The variation of the Earth's magnetic field with time was subtracted from all measurements by linearly extrapolating the change between the successive occupations of the base station. The magnetometer used in the investigation had a field documented precision of plus or minus 0.3 nano Teslas (1 Std. Dev.) of the total magnetic field at the Grassy Island CDF site. The vertical magnetic gradient of the Earth's total magnetic field exhibited a precision of plus or minus 2.2 nano Teslas/meter (1 Std. Dev.). Both quality control measurements were based upon 18 relocations of the same point throughout the geophysical survey.

9. A Geonics EM-34 electromagnetic conductivity device, serial number 8502004, was employed for the conductivity investigation. An intercoil spacing between the transmitter and receiver loop of 10 meters was used. By using a co-planer horizontal dipole orientation, an nominal investigative depth of 7.5 meters (25 feet) plus or minus 2 meters (6.5 feet) is achieved. This was almost equal to the depth of burial of the paint drums, 6 to 7.5 meters (20 to 25 feet). Another investigation using co-planer vertical dipole orientations of

the transmitter and receiver coils allowed an exploration depth of 15 meters (50 feet). However this transmitter and receiver geometry is very sensitive to small mis-alignments and leveling of the transmitter and receiving coils. Although equipment was field improvised to conduct this deeper investigative survey, the results should only be used to verify the continuity of similar subsurface conditions and materials from 7.5 to 15 meters in depth at the Grassy Island CDF site. Although coil leveling problems occurred using the co-planer vertical dipole orientation, the initial study using co-planar horizontal dipole coils produced excellent results. Conductivities are measured in milli Seimens/meter. To convert these values into more familiar resistivity units (ohm-meters) it is necessary to divide the conductivity value into 1000.

10. Each geophysical survey for the Grassy Island CDF investigation is represented by a series of figures. These include: (1) The location points of the measurements in the survey coordinate system. (2) The final value of the measurement after corrections have been applied (conductivity in milli Seimens/meter, total magnetic field in nano Teslas, vertical gradient of the total magnetic field in nano Teslas/meter). (3) A contoured plot of the geophysical data. (4) Two perspective views of the data at different front and back angles. Additional work was performed on the total magnetic field data. A 2nd order polynomial surface was fitted to the magnetic field data by least square residuals. This data surface fit was used to remove a high regional horizontal gradient in the Grassy Island CDF area which is produced by a much deeper geological source. This 2nd order fit was subtracted from the total field data. This process left a "residual" which when contoured exhibits the local magnetic field anomalies associated with ferrous objects of shallow depth. For this reason the total field magnetic survey has these additional figures: (1) The drift corrected magnetic field data. (2) The second order polynomial surface. The subtracted

residual was then contoured and presented with two different perspectives similar to the other geophysical surveys.

#### Electromagnetic Horizontal Dipole Surveys I and II

11. Two electromagnetic horizontal co-planer dipole coil orientation surveys were performed using a 10 meter intercoil separation. In this survey mode the coils are held vertically with one coil in line to the next. The two coils, transmitter and receiver, define a single vertical plane with the axis of both coils being horizontal. This is the origin of the term "horizontal co-planar". This coil separation and configuration had a principal depth of investigation of approximately 18.5 to 31.5 feet which was very close to the depth of interest. By conducting this survey twice, a demonstrated repeatability of the electromagnetic surveys was established. The results of the first horizontal dipole survey (GRAHEM) are seen in Figures 2 through 6. Figure 2 indicates the data location points. Figure 3 displays the measured conductivity values in milli Seimens per meter. Figure 4 displays the contoured conductivity values. Figure 5 and 6 are two 3-D perspectives of the data. Three areas containing a higher conductivity (possibly attributable to ferrous metal) are indicated in Figure 4. From south to north these are located at:

- (1) 20' Northing, 50' Easting.
- (2) 170' to 230' Northing, 30' Easting.
- (3) 420' Northing, 25' Easting.

The investigation was repeated again with the survey (GRAHEM2), Figures 7 through 11. As seen in Figure 9, from south to north significant anomalies which may indicate concentrations of ferrous metal in the subsurface are found at (1) 20' Northing, 50' Easting. (2) 175' to 225' Northing, 35' Easting (3) 440' Northing and 25' Easting. The results from the second horizontal dipole electromagnetic survey are closely similar to the initial electromagnetic survey. In both of these electromagnetic surveys and the one to be discussed, the conductivity values drop off toward the north-south baseline,

running from 0' to 480' Northing, 0' Easting. This drop off which parallels the baseline is due to topographic effects. The baseline is surveyed on top of the impoundment dike. To the east of the dike is a drop-off of a few feet. Beyond this short slope (to the east of the dike) is the disposed dredged material over which the geophysical investigations were conducted. To the west of the dike is a downward slope of approximately 35° from horizontal. This slope continues until it reaches the water's edge, about 20-25 feet vertically from the crest of the dike. Since air is a good insulator and has a low conductivity, the electromagnetic surveys close to the crest of the dike see this effect. As the survey trace approaches the dike's edge a higher percentage of the space aside of the transmitter and receiver is low conductive air rather than higher conductive earth materials. Consequently the conductive measurements close to the north-south base line over the centerline of the dike has lower reported values.

#### Electromagnetic Vertical Dipole Survey

12. The results of the electromagnetic vertical co-planer survey are seen in Figures 12 through 16. The data are represented in the same sequence of Figures as presented in Figures 2 through 6. This field technique involves utilizing the transmitter and receiver coils in a horizontal plane with the axial component of the coils vertical. An intercoil separation of 10 meters was used which allowed a nominal depth of investigation of 37 to 65 feet. This depth is significantly greater than the depth of probable burial of the paint canisters. The measured conductivities are somewhat erratic due to small variations in the leveling of the electromagnetic coils. Plastic "bulls eye" levels mounted on the coils to achieve precise orientations are recommended for similar future investigations. The results shown in Figure 13 display a conductive anomaly of greater than 64 milli Seimens at 195' Northing, 55' Easting. This anomalous area is coincident

with area 2 in Figures 4 and 9, and indicates that the feature has depth extent, i.e. it is not just surficial and is most likely a deeper extension of the same north to south elongated feature identified at 170' to 230' Northing, 30' Easting and 175' to 225' Northing, 35' Easting.

#### Vertical Magnetic Gradient Survey

13. The vertical magnetic gradient investigation (GRAGRD) is represented in Figures 17 to 21. Figure 17 exhibits the locations of all of the measurements of the vertical gradient of the total magnetic field in nano Teslas per meter. These values are displayed in Figure 18 and the results contoured in Figure 19. Material of high positive magnetic susceptibility, hence containing ferrous iron is located near 15' Northing, 35' Easting. This sharply increasing positive magnetic gradient is surrounded by spatially wider (20 to 30 feet) negative gradient "halo", especially to the west and north of the positive gradient location, see Figure 21. Such a large negative anomaly to the north of the positive anomaly may indicate that a still larger concentration of ferrous material is present in the subsurface south of about 0' Northing, 40' Easting. The magnetic gradient anomaly detected at 15' Northing, 40' Easting may be part of this potentially larger magnetically susceptible mass south of the east-west base line. More probably this smaller feature is a separate body but of a smaller volume. A high magnetic gradient characterizes a north to south elongate shaped feature extending from 165' to 235' Northing, 30' Easting. This object was also clearly resolved by the electromagnetic survey. Another mass of high magnetic susceptibility is located at the area of 400' Northing, 30' Easting. This anomaly is more difficult to interpret as it is surrounded by numerous smaller magnetic gradient highs which complicate the overall resolution of this feature. This anomaly is probably the same feature as identified at about

420' Northing, 25' Easting on the horizontal dipole electromagnetic surveys.

#### Total Magnetic Field Survey

14. Results of the total field magnetic investigation (GRAMAG) are represented in Figures 22 to 26. The values for the individual measurements are displayed in Figure 23. To facilitate the printing of these values, 56,000 nano Teslas were subtracted from each value. This greatly assisted in the plotting routines used to portray the data. In this manner only 4 numbers rather than 6 were printed. This investigation detected the same three subsurface features as identified by the previous studies using electromagnetic horizontal dipoles and the vertical gradient of the total magnetic field. From south to north the three features are located at: (1) 10' Northing, 45' Easting. (2) 200' to 240' Northing, 40' Easting. (3) 410' Northing, 25' Easting. A strong local magnetic gradient, geological in origin and unrelated to the investigation is evident in the data. The total earth's field which includes this local effect is modeled by a second order polynomial surface displayed in Figures 27 and 28 (GRMAG32). This modeled magnetic field was then subtracted from the measured total magnetic field. The difference between the model and the field data is displayed in Figures 29 and 30 (GRMRS D). These perspectives of the processed data are commonly referred to as the "residual total magnetic field". This processing is generally done to display the local magnetic anomalies in a manner which is easier to visualize.

#### Conclusions

15. The location of the three anomalies which represent concentrations of ferrous material in the subsurface are summarized in Table 1. Excellent results were obtained with

each survey, with the exception of the GRAVEM which needed more precision leveling of the coils in the field investigation. It is evident that the locations of the "center of mass" of these anomalies are consistent to approximately 20 feet based on the distribution of locations in the above table. The anomaly which has the highest probability of corresponding to the paint cannisters is number 3. This anomaly is characteristic of the weaker more subtle geophysical response which is expected to be found. This anticipated geophysical expression is based upon the estimated number of paint cannisters, and the depth and length of time from burial. The location is approximately 70 to 100 feet from the crane operator's recollected burial site location. Anomaly number 2 is a large ferrous object worthy of additional investigation but is probably too large to be the paint cannisters. Anomaly number 1 has the geophysical expression which is most likely the correct size and shape for the cannisters, but is further south of the anticipated burial location. Due to the geophysical response of this object which is similar to the anticipated expression of the cannisters, it also merits further investigation.

16. The geophysical anomalies determined from this investigation are most likely ferrous iron material. This is based upon the very similar response of these bodies from both the magnetic and electromagnetic field surveys. It is also possible that the anomalies are due to localized concentrations of taconite pellets or other iron ores which were deposited as the result of the dredging operations. If additional augering is performed, representative samples from various depths should be analyzed in a magnetic susceptibility bridge. This device measures the magnetic susceptibility of the material. The materials should be examined optically or by other means for ores of iron if large magnetic susceptibility values are determined.

## Recommendations

17. It is recommended that each of the geophysical targets 1, 2 and 3 be augured with at least two borings and the material regularly sampled to a maximum depth of 35 to 40 feet in the subsurface. It is important to attempt to determine what ferrous metal features are responsible for these anomalous electrical conductivities and variations in the magnetic field. Soil samples should be collected, examined and measured for magnetic susceptibility to determine if these anomalies are actually caused by iron ore such as taconite pellets. Chemical analyses should be performed on the collected soils and fluids to determine if paint compounds or solvents are present which are common to the US Air Force paint disposed on the confined disposal facility. The augured holes should be completed in a manner to allow future fluid samples to be collected at various depths in the subsurface. The location of the three geophysical anomalies should be surveyed and monumentalized to allow easy location for future reference.

Table i

Location of Subsurface Anomals Detected  
by the Geophysical Surveys

	<u>GRAHEM</u>	<u>GRAHEM2</u>	<u>GRAVEM</u>	<u>GRAGRD</u>	<u>GRAMAG</u>
1.	20' N 30' E	20' N 50' E		15' N 35' E	10' N 45' E
2.	170-230' N 30' E	175-225' N 35' E	195' N 55' E	135-235' N 30' E	200-240' N 40' E
3.	420' N 25' E	440' N 50' E		400' N 30' E	410' N 25' E

Location of the Augered Holes at the Location of the  
Paint Cans as Indicated by Mr. Bill Packer

- |    |        |    |        |
|----|--------|----|--------|
| 1. | 349' N | 2. | 368' N |
|    | 34' E  |    | 18' E  |

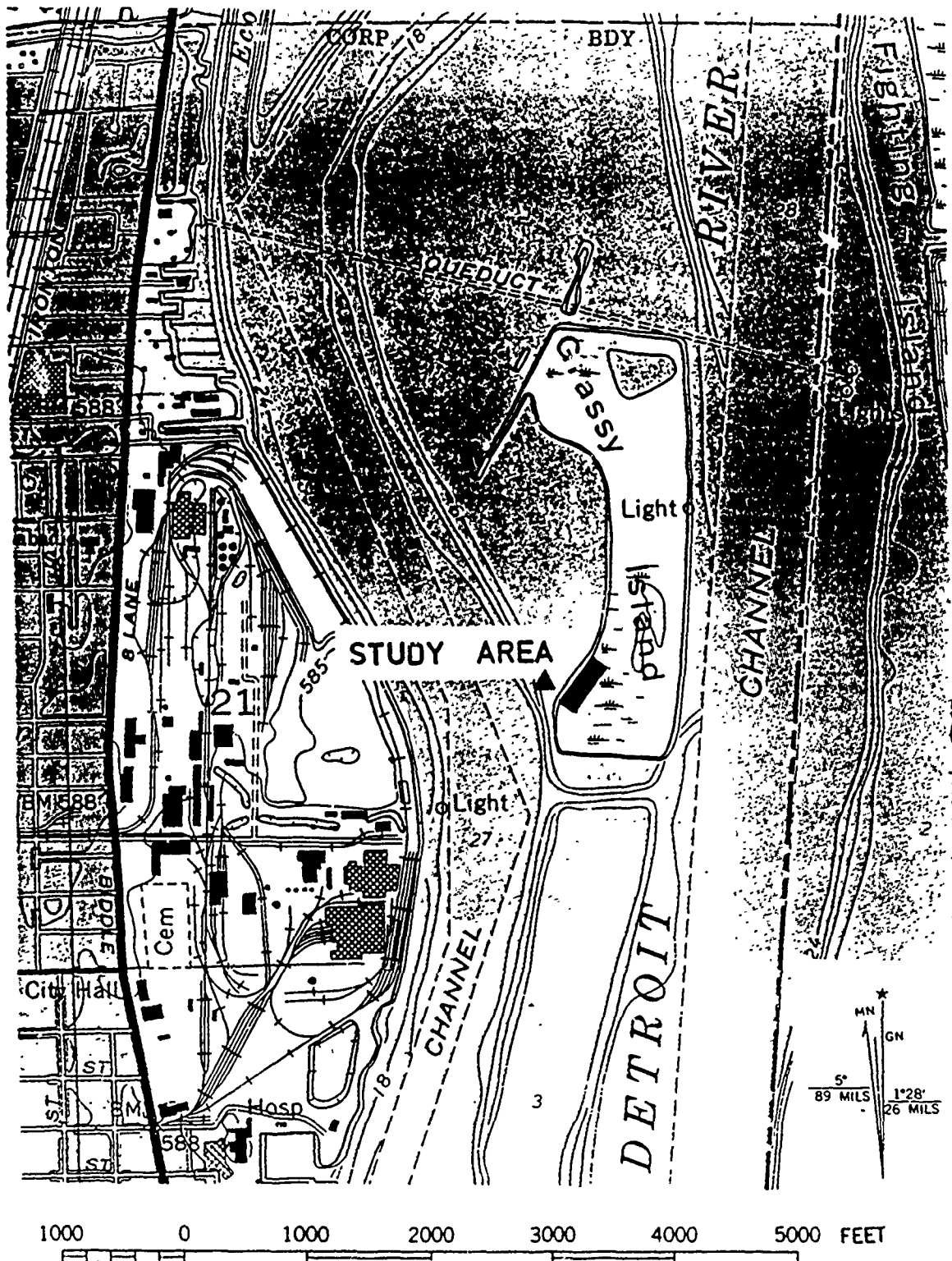

Figure 1. General vicinity of the Grassy Island study area

GRAHEM, HORIZONTAL  
DIPOLE SURVEY

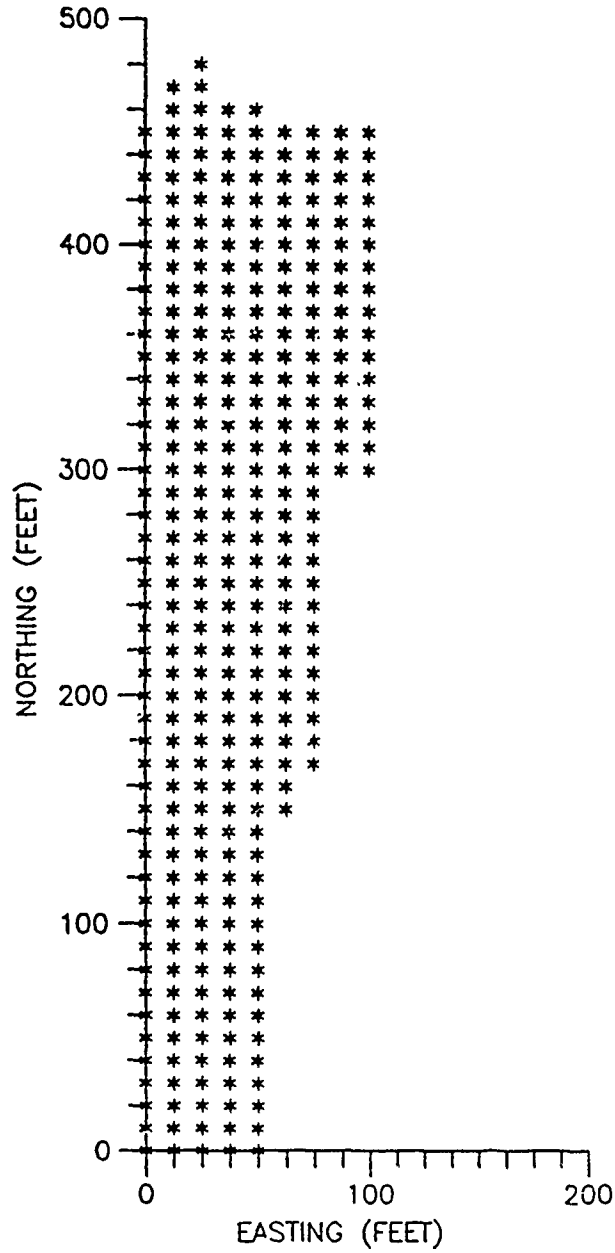

Figure 2. Data location points of the first electromagnetic horizontal dipole survey

# GRAHEM HORIZONTAL DIPOLE SURVEY I

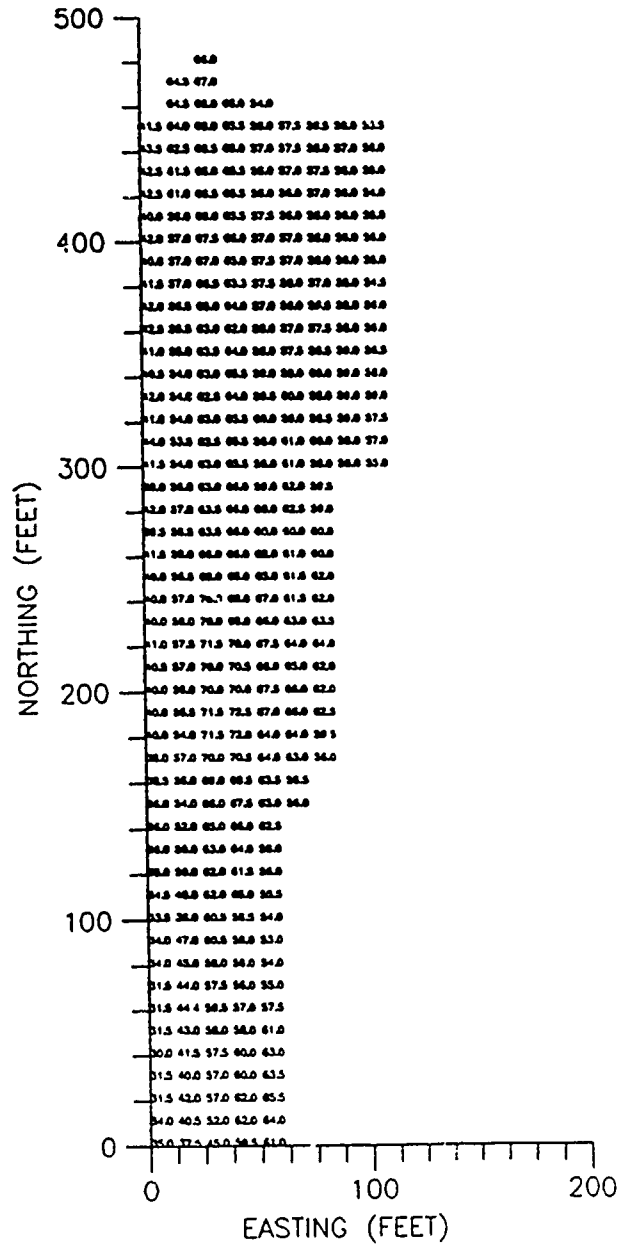

Figure 3. Data values in milliseimens/m of the first electromagnetic horizontal dipole survey

GRAHEM, HORIZONTAL DIPOLE SURVEY I

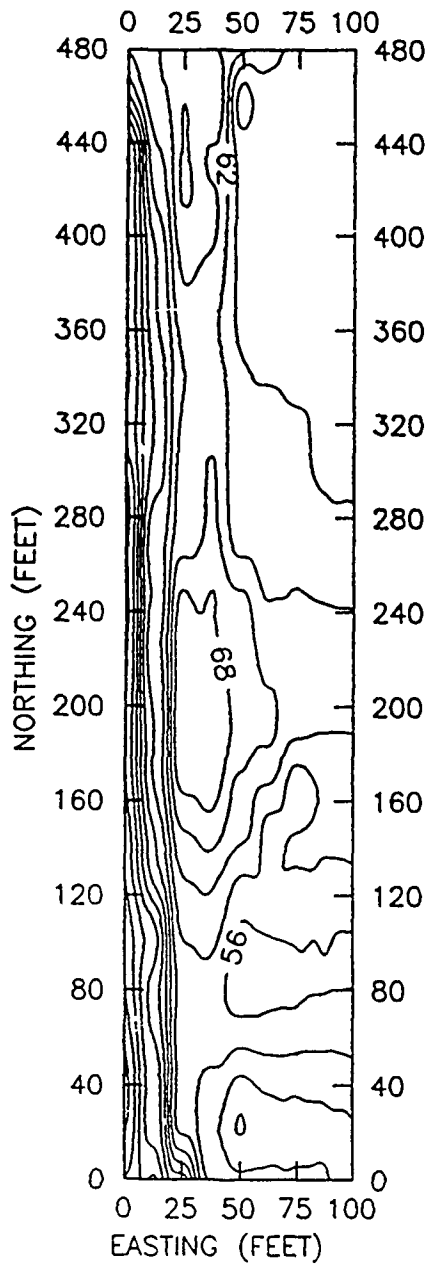
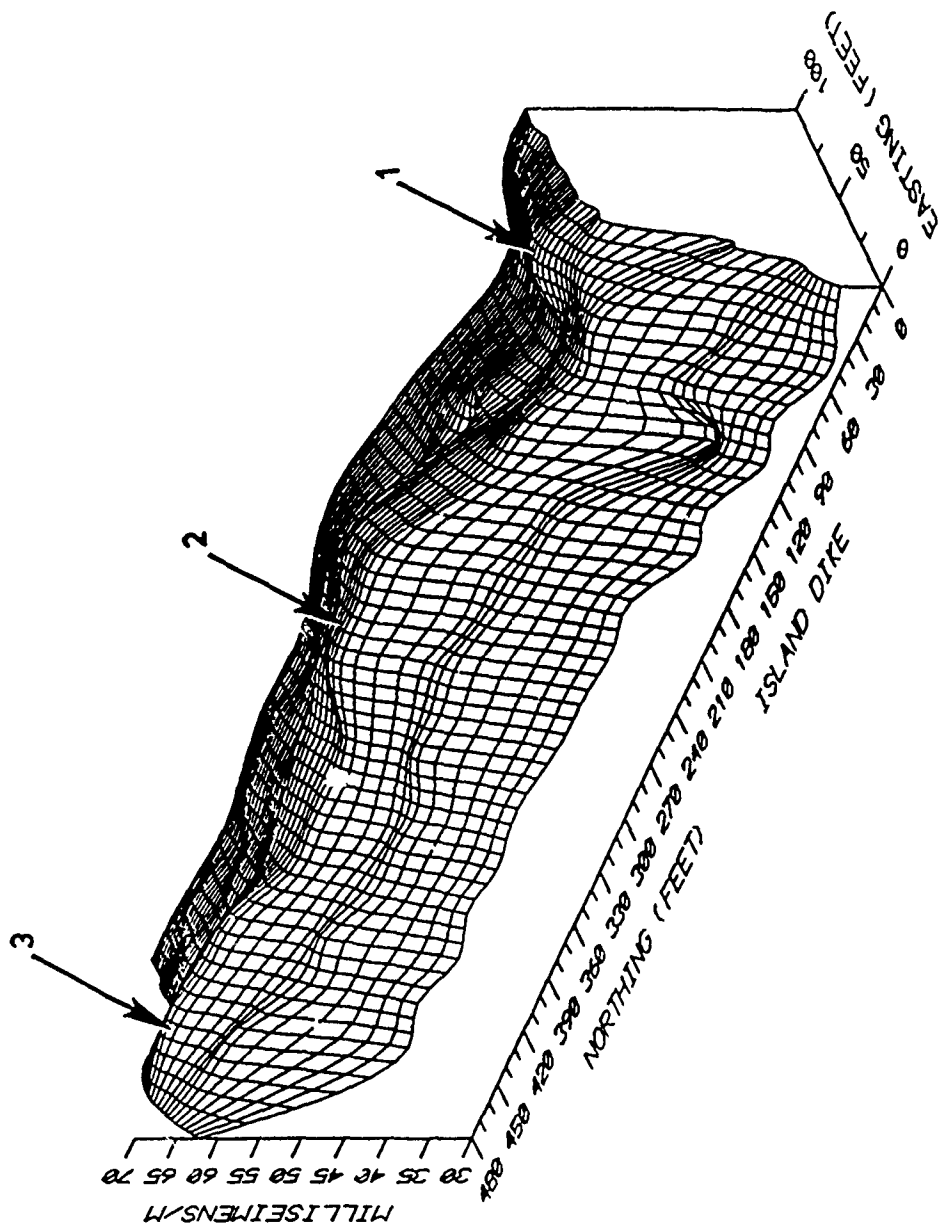
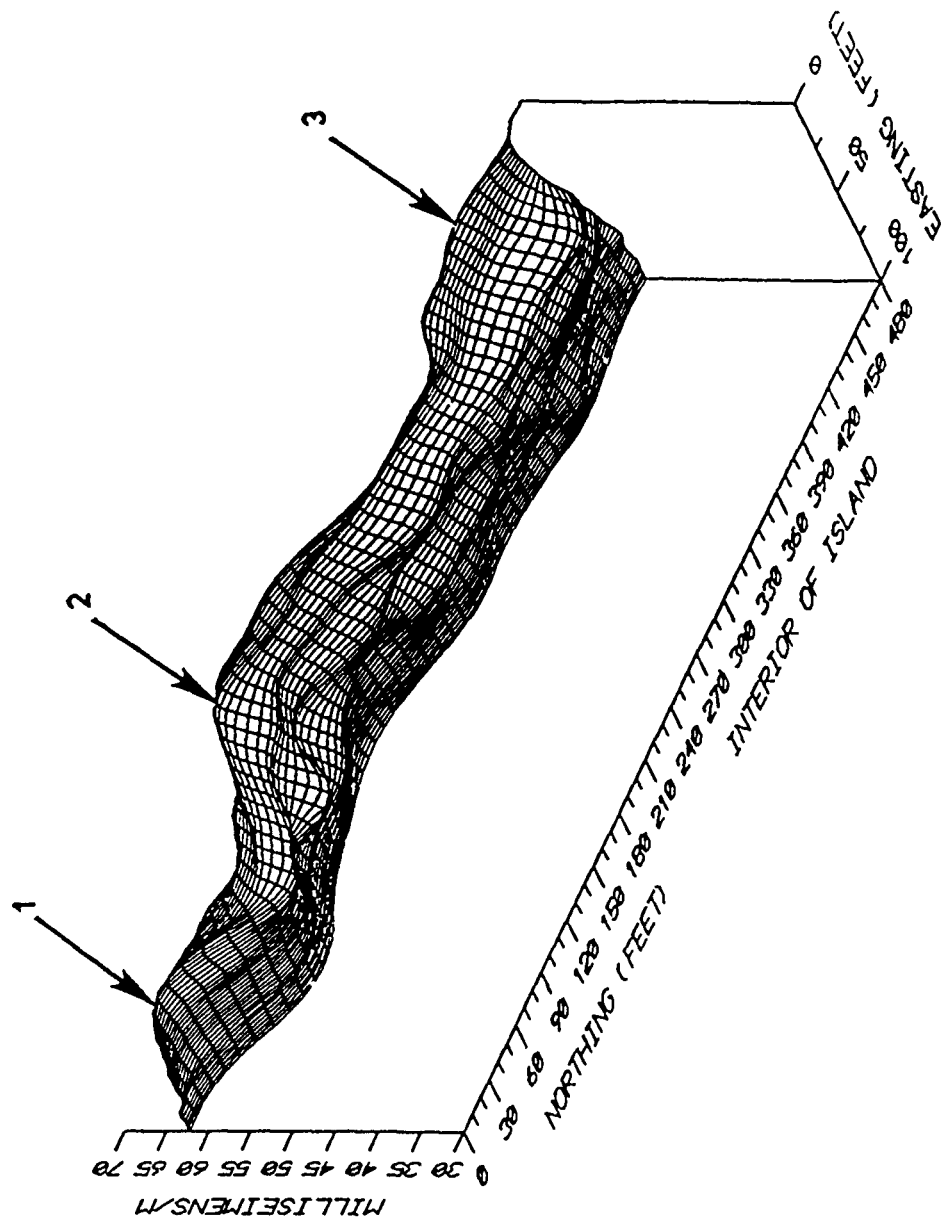

Figure 4. Contoured conductivity values in milliseimens/m of the first horizontal dipole survey



GRAHEM, HORIZONTAL DIPOLE SURVEY I

Figure 5. Eastward looking 3-D perspective of conductivity values in milliseimens/m of the first electromagnetic horizontal dipole survey



GRAHEM, HORIZONTAL DIPOLE SURVEY I

Figure 6. Westward looking 3-D perspective of conductivity values in milliseimens/m of the first electromagnetic horizontal dipole survey

GRAHEM2, HORIZONTAL DIPOLE SURVEY

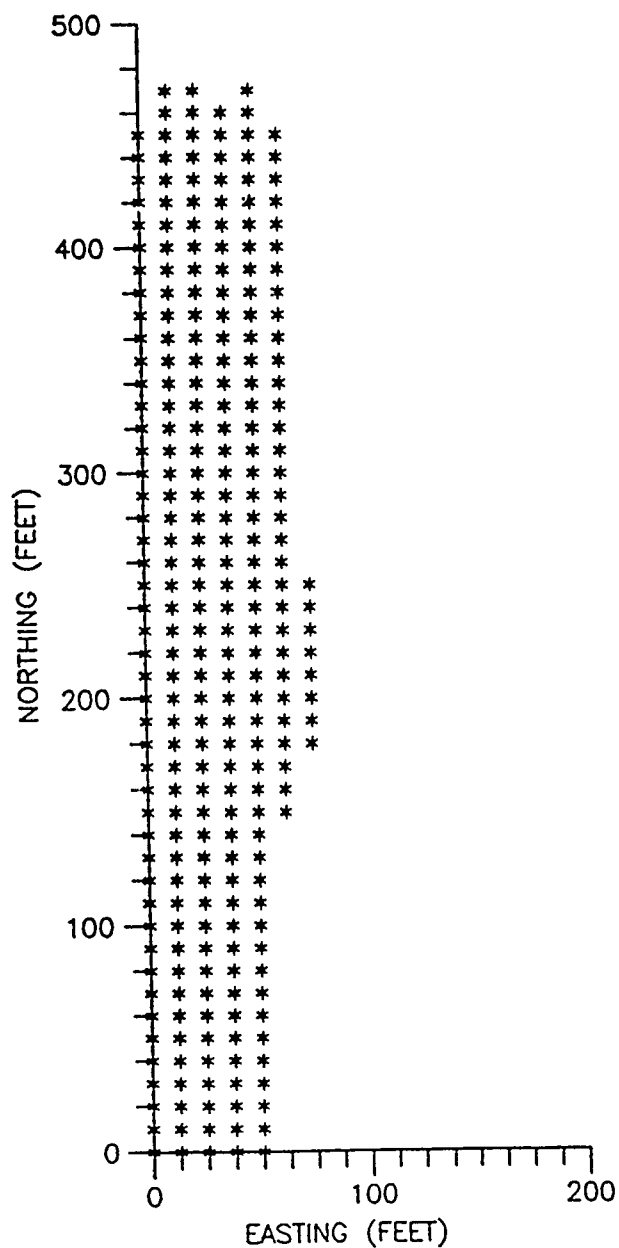

Figure 7. Data location points of the second electromagnetic horizontal dipole survey

# GRAHEM2 HORIZONTAL DIPOLE SURVEY II

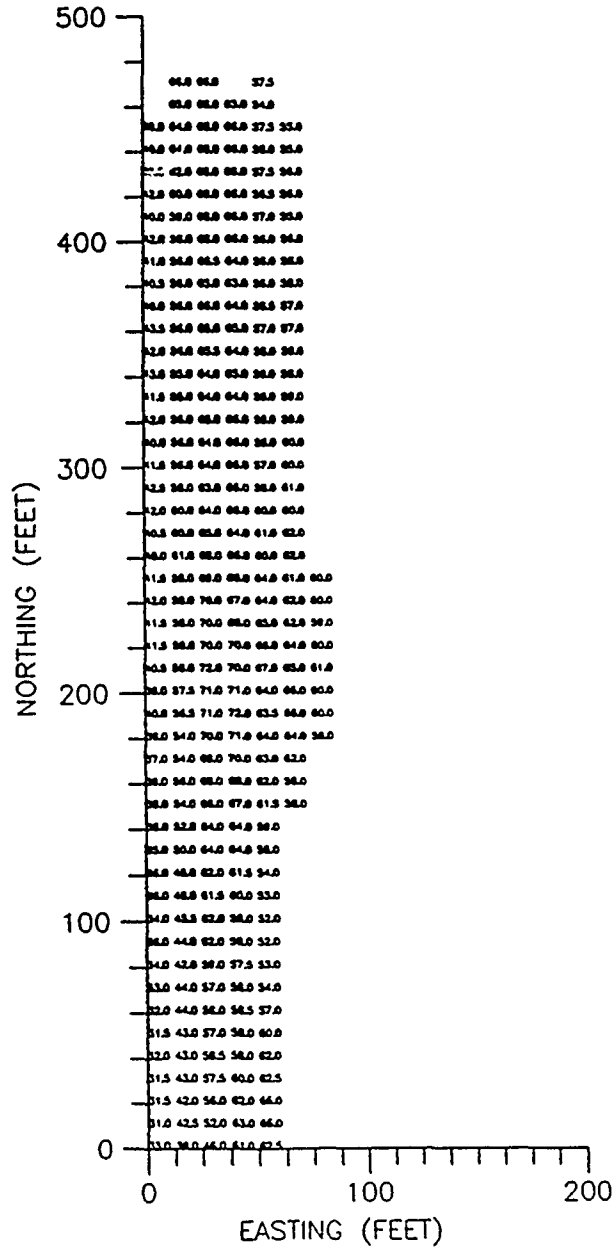

Figure 8. Data values in milliseimens/m of the second electromagnetic horizontal dipole survey

GRAHEM2, HORIZONTAL DIPOLE SURVEY II

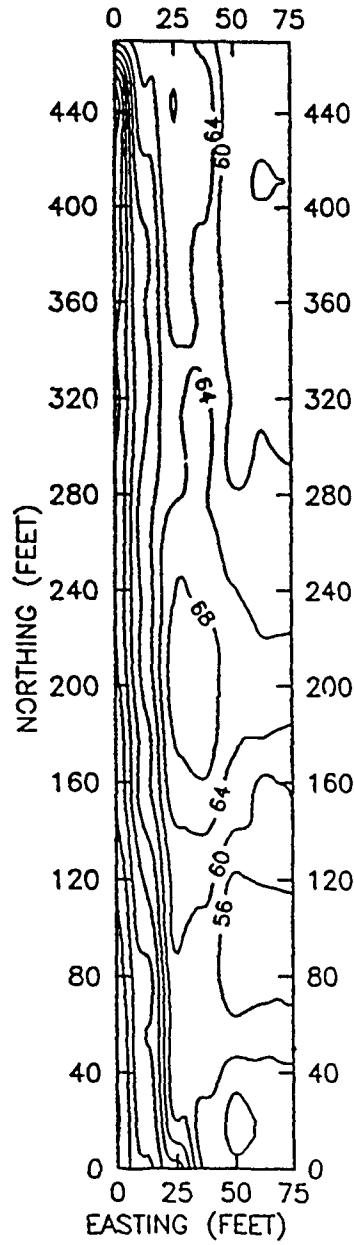
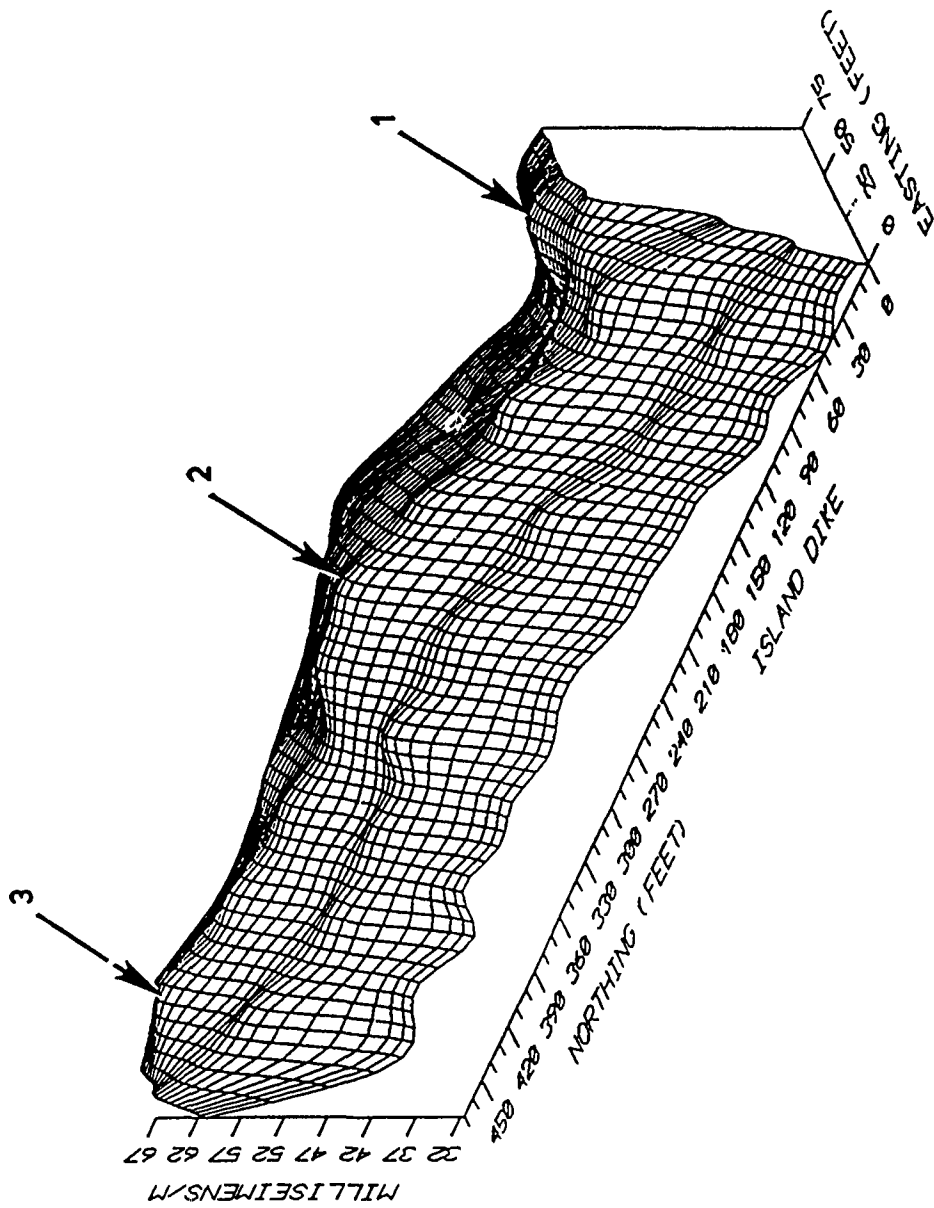
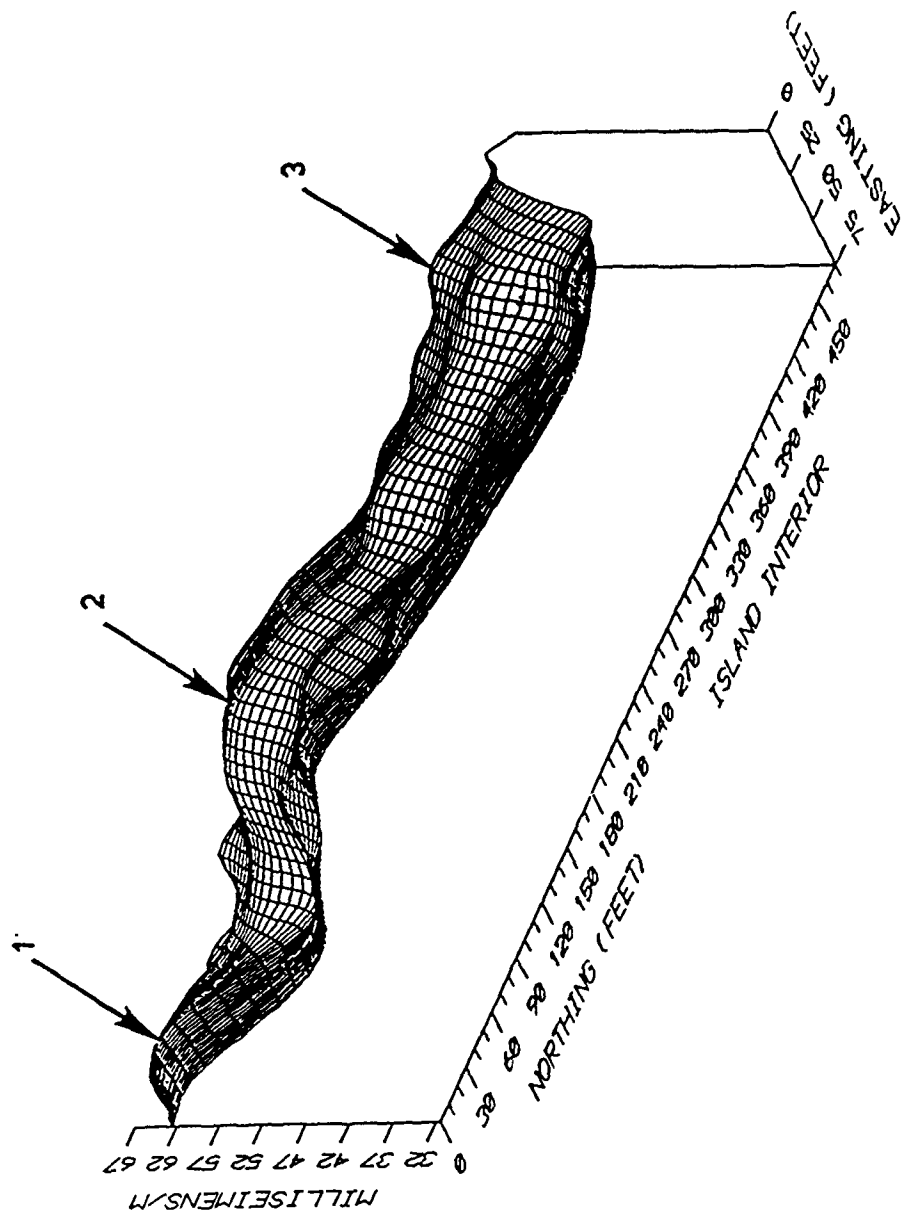

Figure 9. Contoured conductivity values in milliseimens/m of the second horizontal dipole electromagnetic survey



GRAHEM2, HORIZONTAL DIPOLE SURVEY II

Figure 10. Eastward looking 3-D perspective of conductivity values in milliseimens of the second electromagnetic horizontal dipole survey



GRAHEM2, HORIZONTAL DIPOLE SURVEY II

Figure 11. Westward looking 3-D perspective of conductivity values in milliseimens of the second electromagnetic horizontal dipole survey

GRAVEM, VERTICAL DIPOLE SURVEY

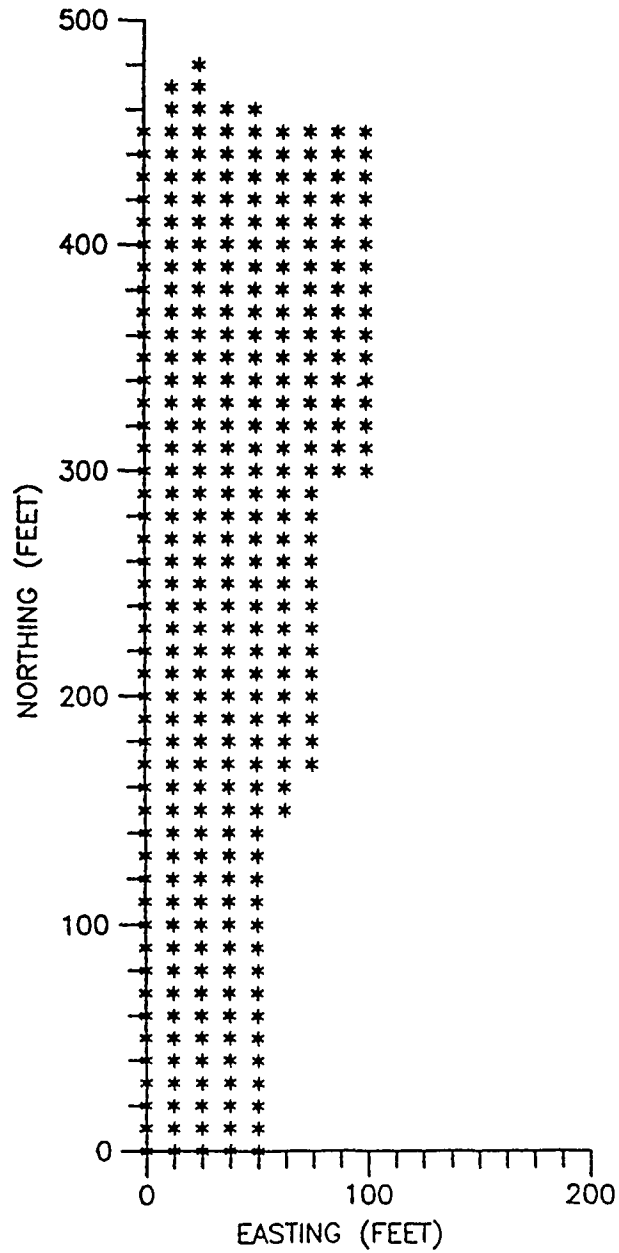

Figure 12. Data location points of the electromagnetic vertical dipole survey

# GRAVEM, VERTICAL DIPOLE SURVEY

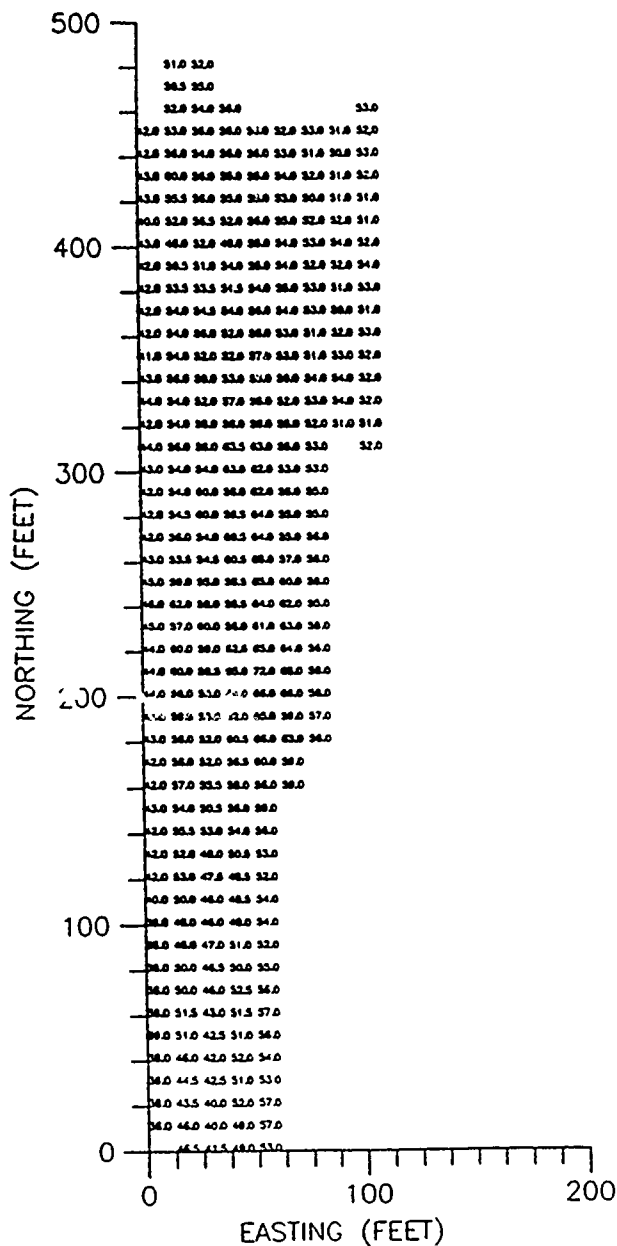

Figure 13. Data values in milliseimens of the electromagnetic vertical dipole survey

GRAVEM, VERTICAL DIPOLE SURVEY

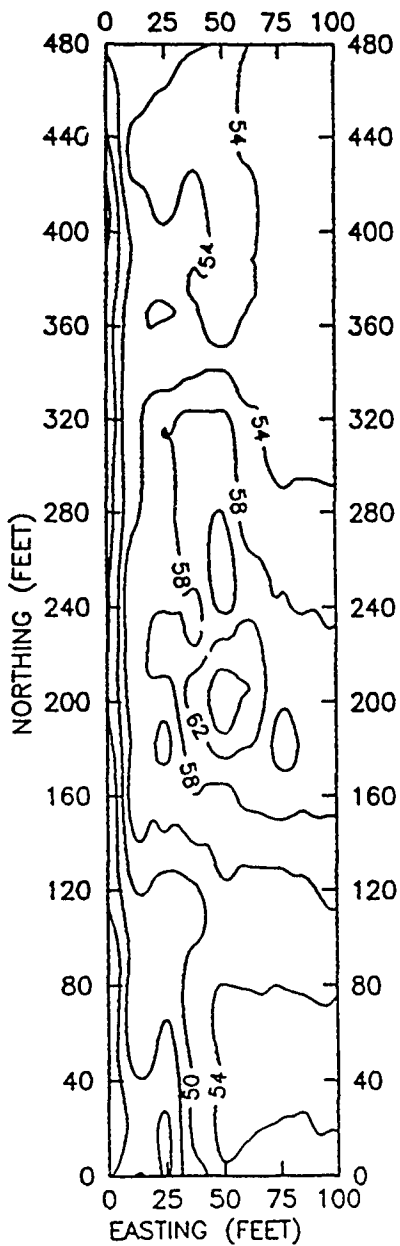
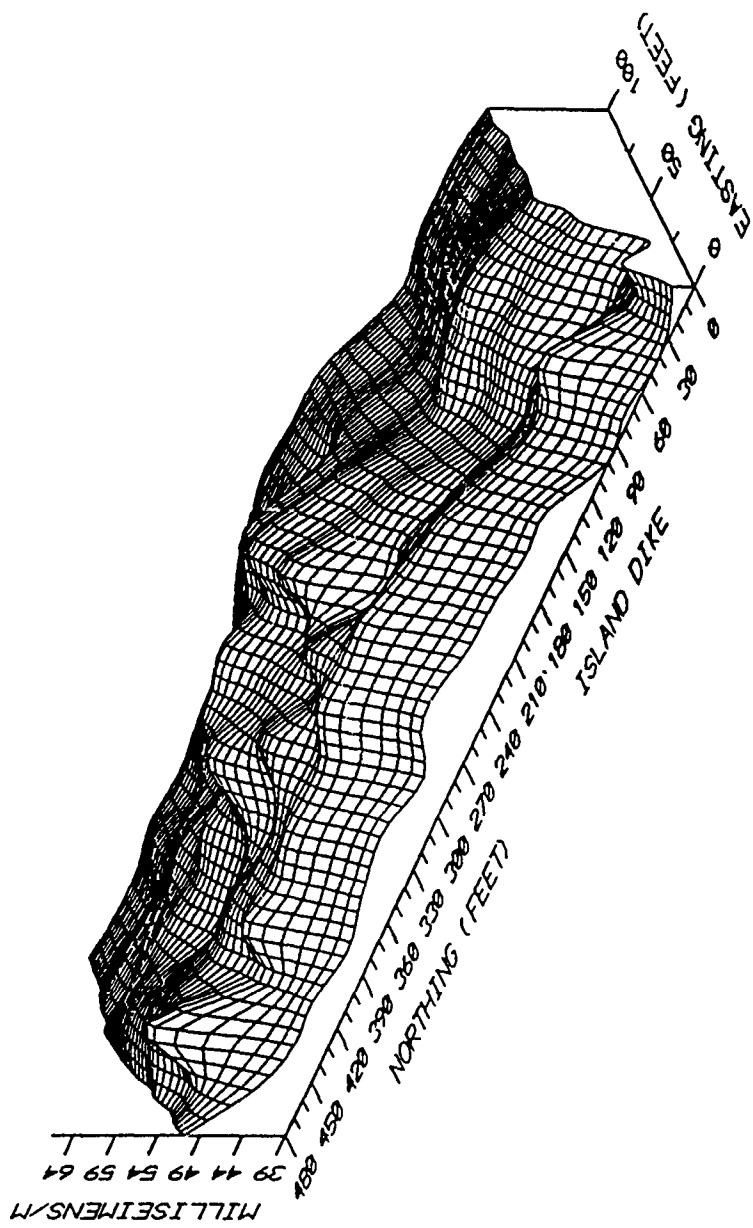
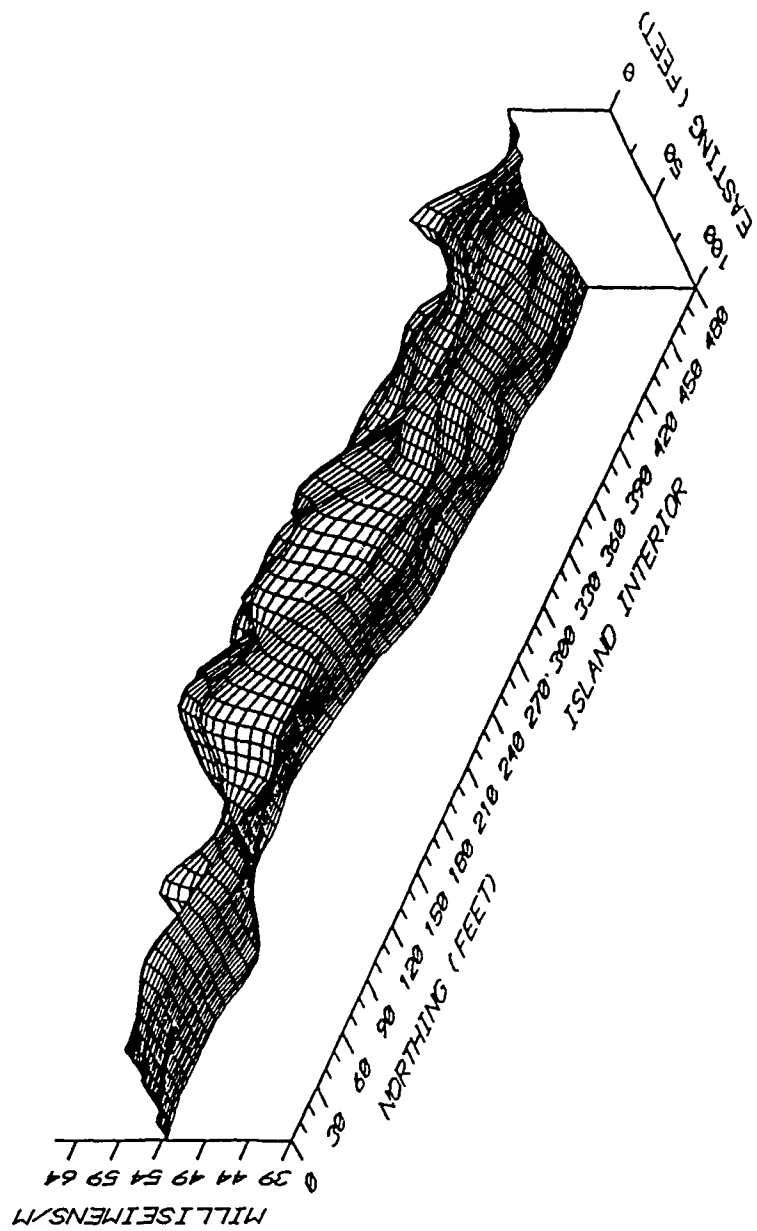

Figure 14. Contoured conductivity values in milliseimens of the electromagnetic vertical dipole survey



GRAVEM, VERTICAL DIPOLE SURVEY

Figure 15. Eastward looking 3-D perspective of conductivity values in milliseimens/m of the electromagnetic vertical dipole survey



GRAVEM, VERTICAL DIPOLE SURVEY

Figure 16. Westward looking 3-D perspective of conductivity values in milliseimens/m of the electromagnetic vertical dipole survey

GRGRD, VERTICAL MAGNETIC GRADIENT INVESTIGATION

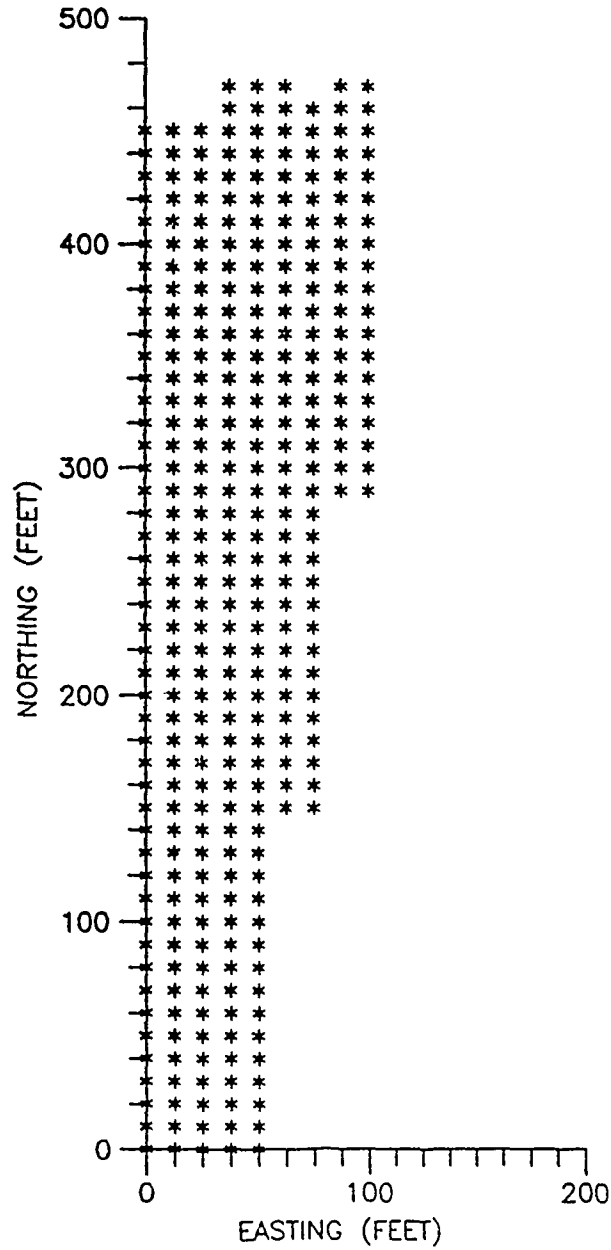

Figure 17. Data location points of the verticle magnetic gradient investigation

GRAGRD, VERTICAL MAGNETIC GRADIENT INVESTIGATION

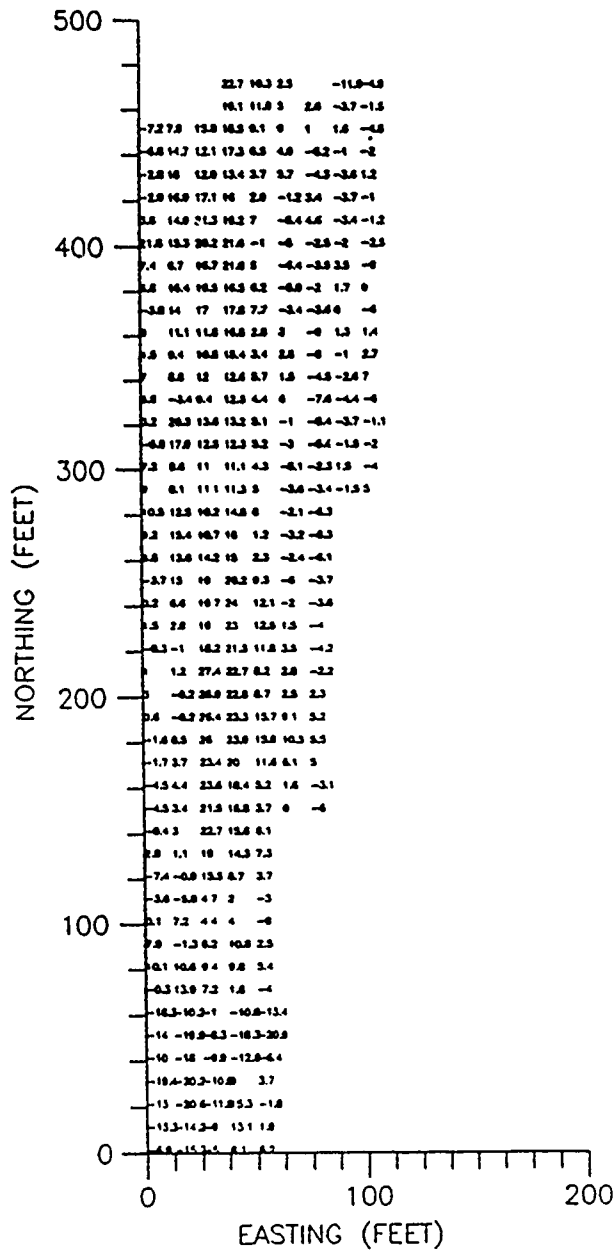

Figure 18. Data values in nano teslas/m of the vertical magnetic gradient investigation

GRAGRD, VERTICAL MAGNETIC GRADIENT INVESTIGATION

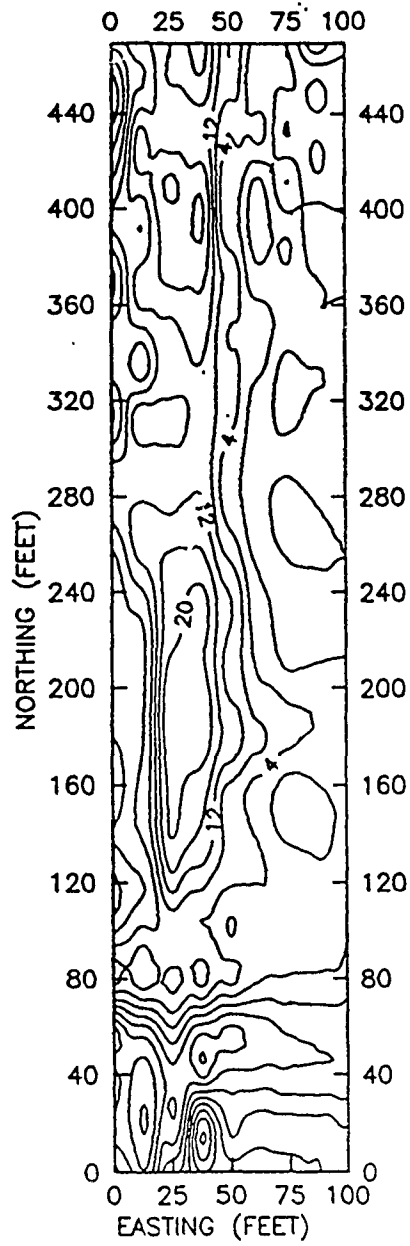
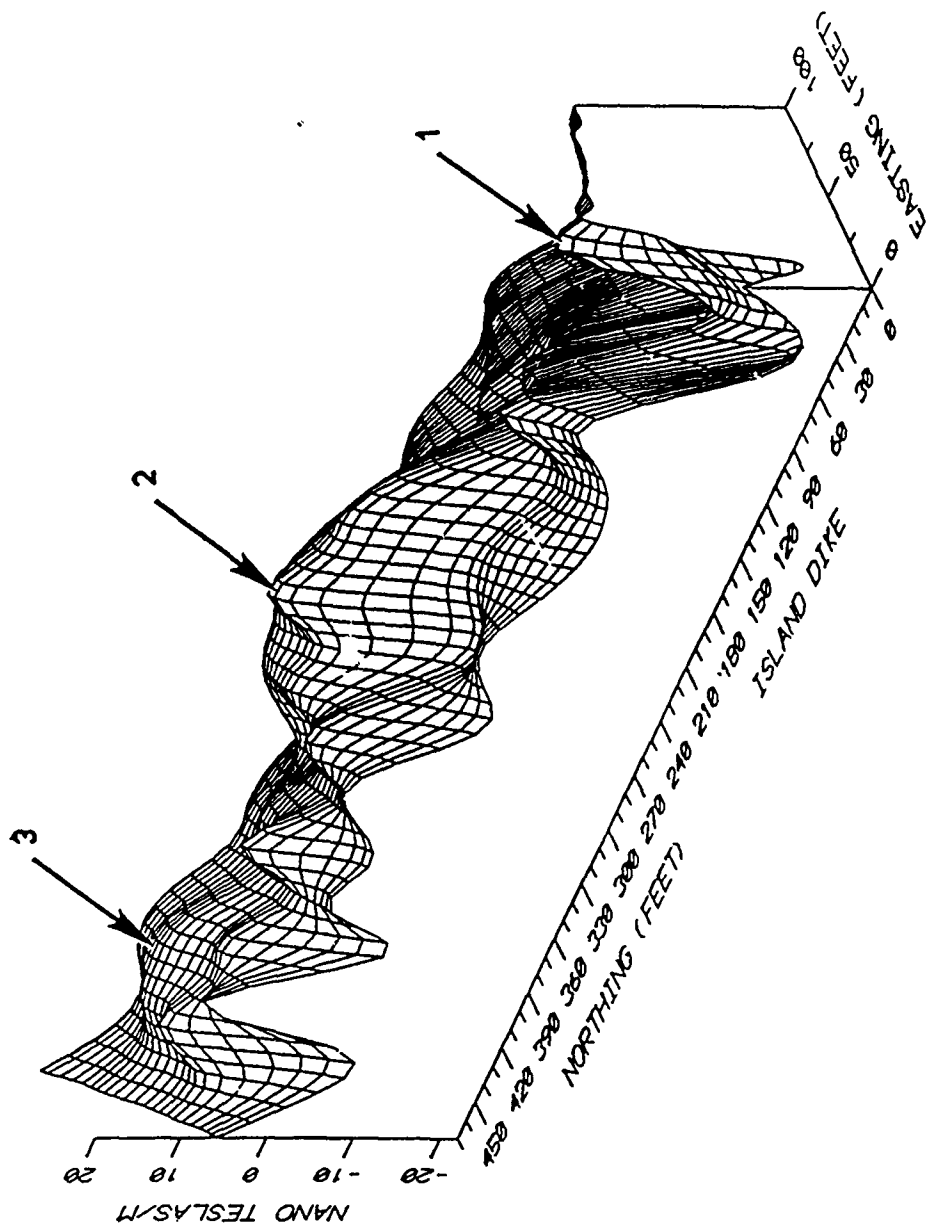
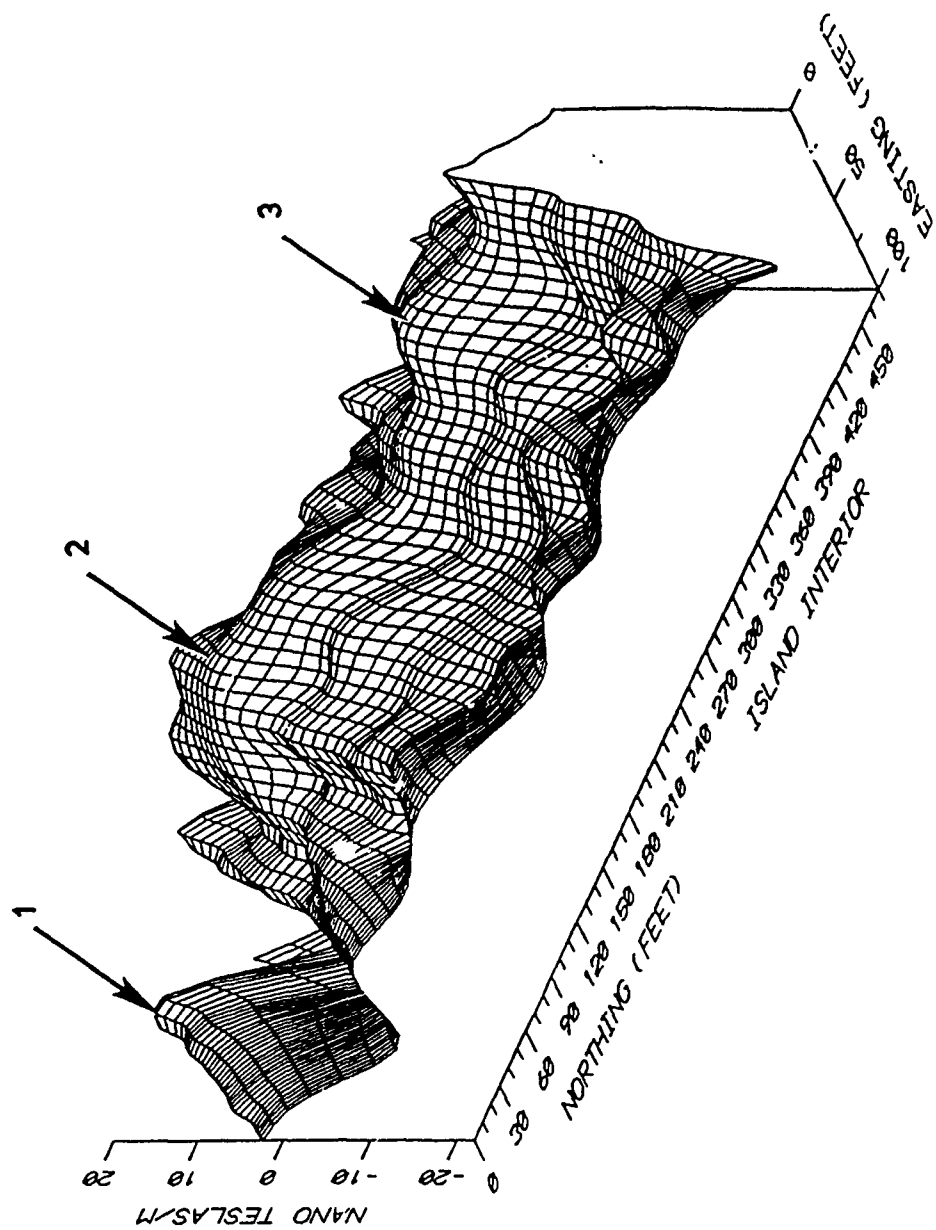

Figure 19. Contoured vertical magnetic gradient values in nano teslas/m



GRAGRD, VERTICAL MAGNETIC GRADIENT INVESTIGATION

Figure 20. Eastward looking 3-D perspective of vertical magnetic gradient data in nano teslas/m



GRAGRD, VERTICAL MAGNETIC GRADIENT INVESTIGATION

Figure 21. Westward looking 3-D perspective of vertical magnetic gradient data in nano teslas/m

GRAMAG, TOTAL FIELD  
MAGNETIC INVESTIGATION

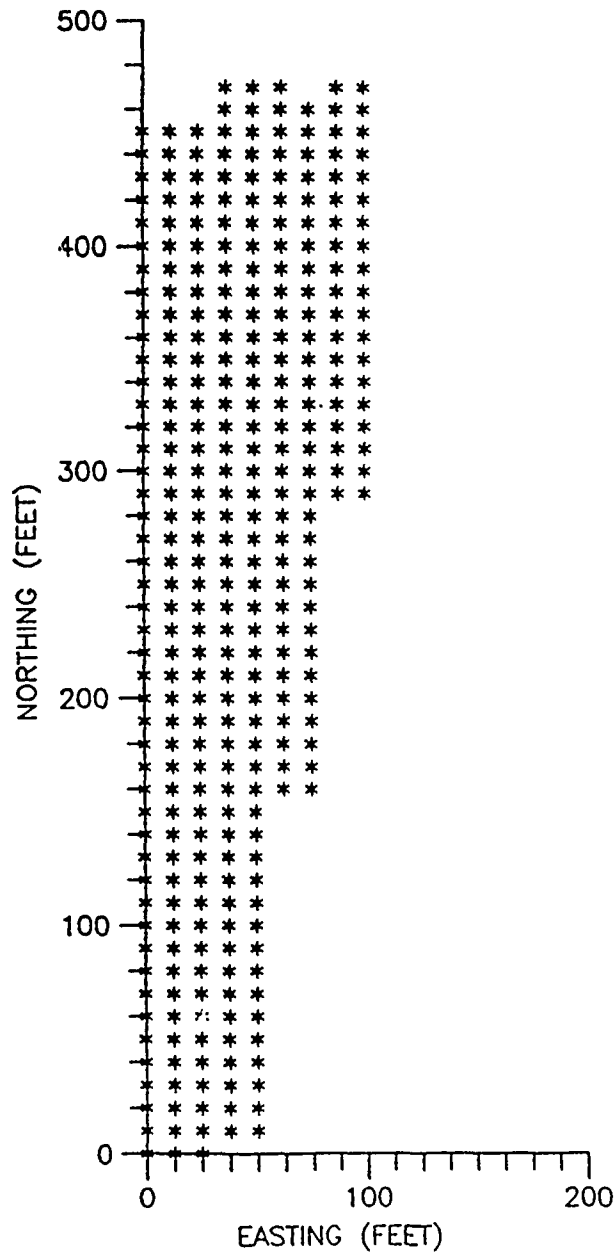

Figure 22. Data location points of the total field magnetic investigation

GRAMAG, TOTAL MAGNETIC INVESTIGATION

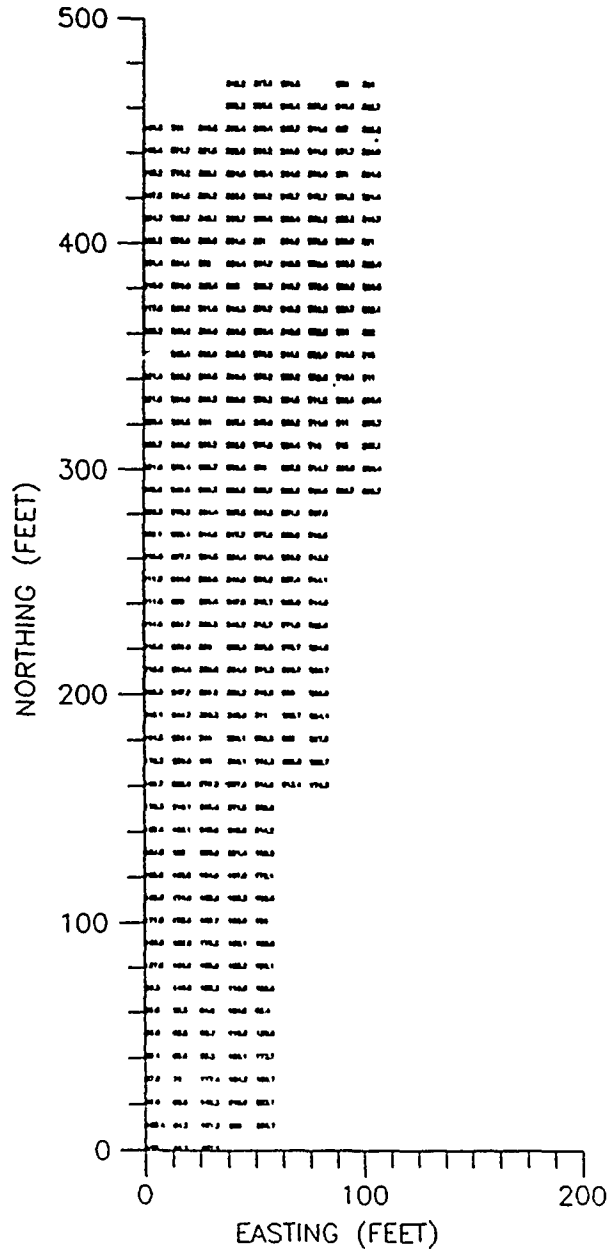

Figure 23. Data values in nano teslas/m of the total field magnetic investigation

GRAMAG, TOTAL FIELD MAGNETIC INVESTIGATION

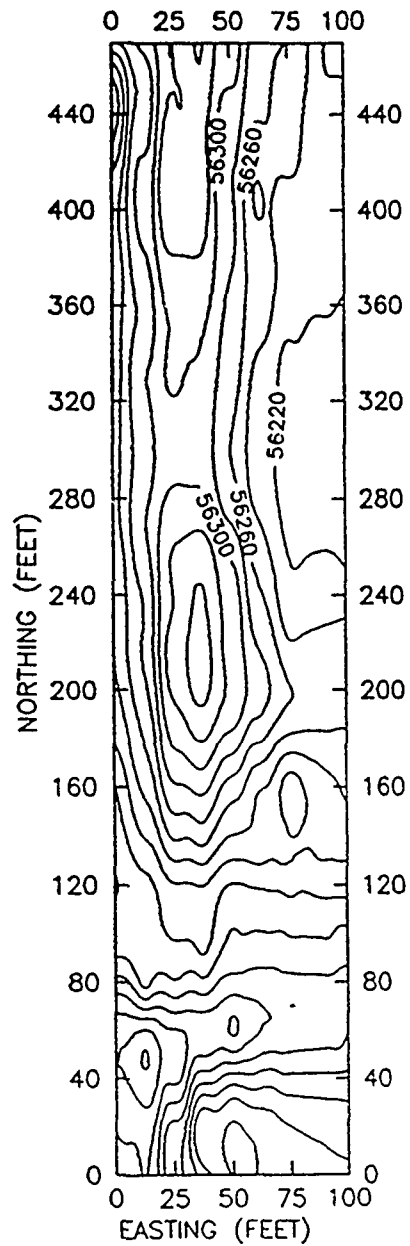
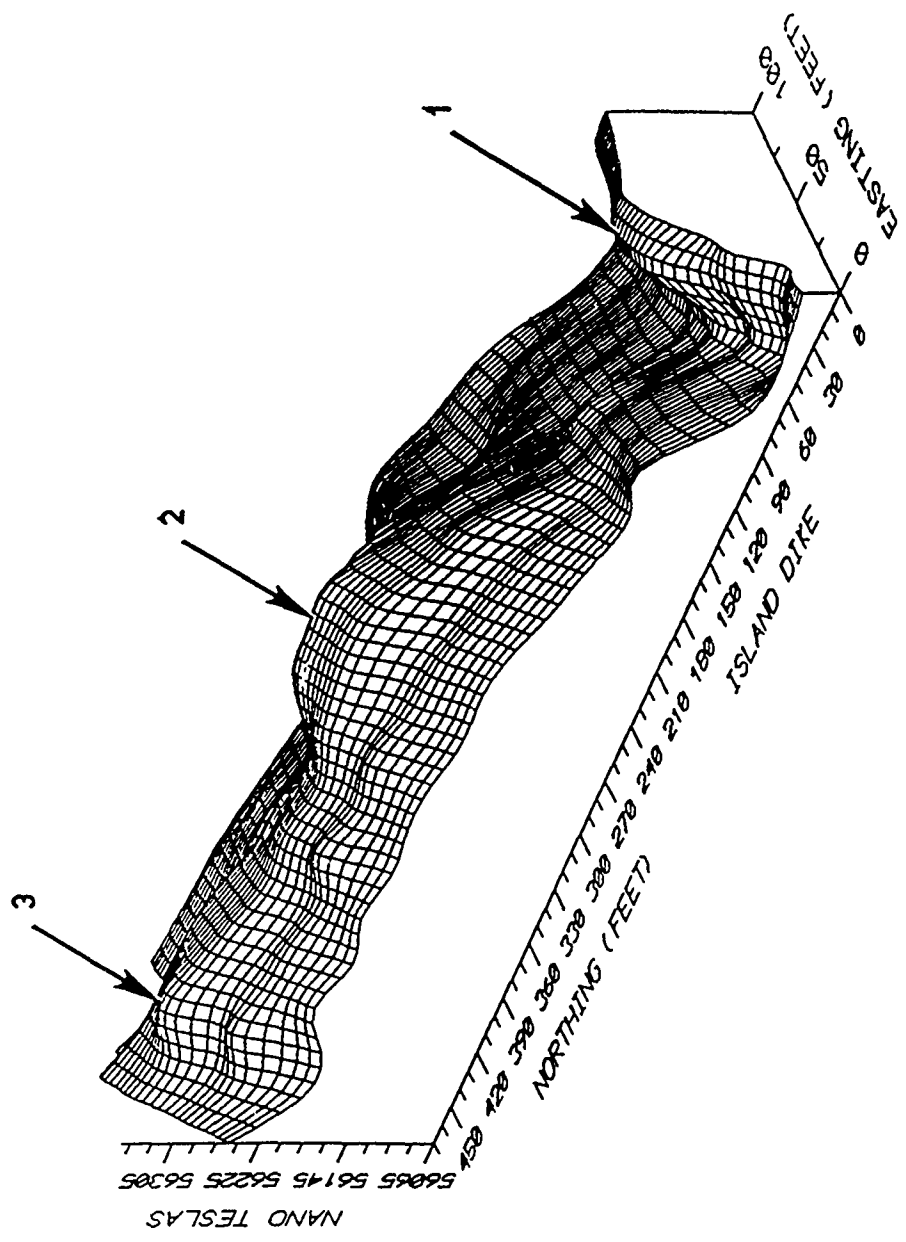
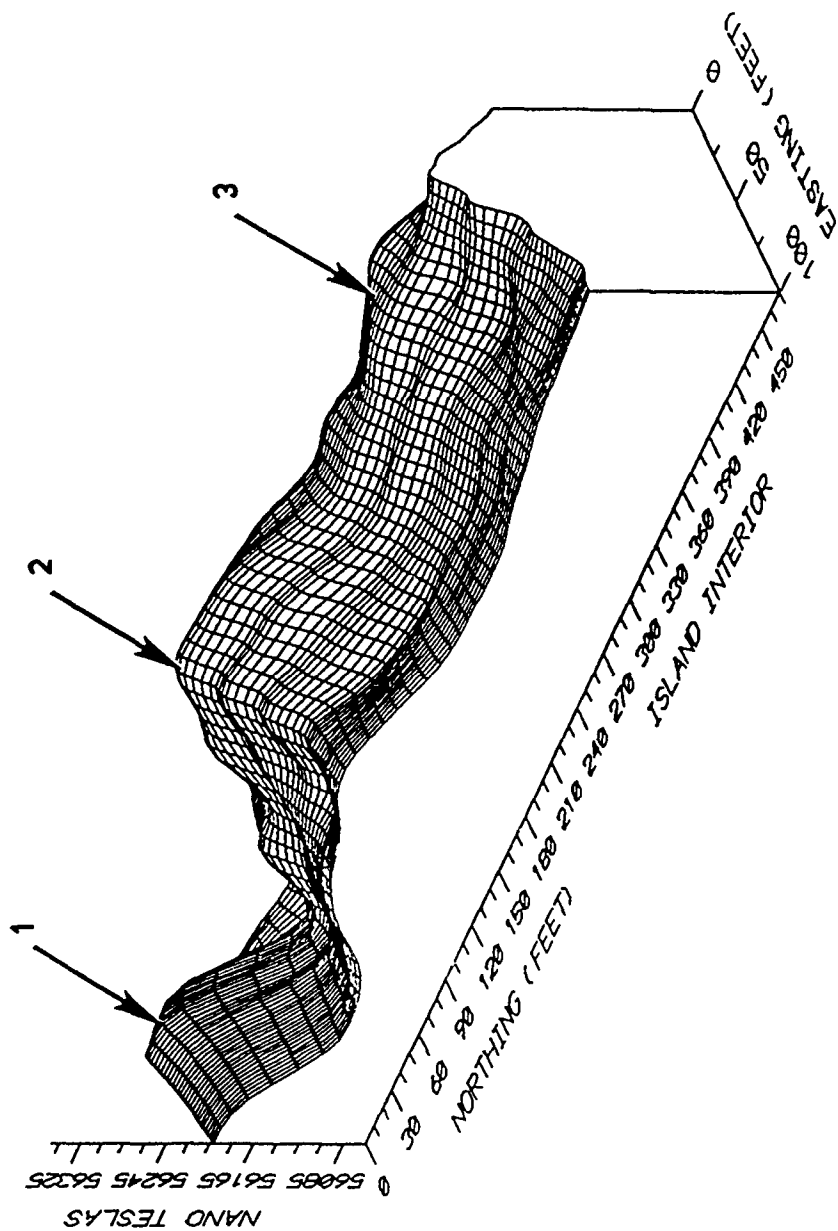

Figure 24. Contoured total field magnetic values in nano teslas



GRAMAG, TOTAL FIELD MAGNETIC INVESTIGATION

Figure 25. Eastward looking 3-D perspective of total field magnetic data in nano teslas



GRAMAG, TOTAL FIELD MAGNETIC INVESTIGATION

Figure 26. Westward looking 3-D perspective of total field magnetic data in nano teslas

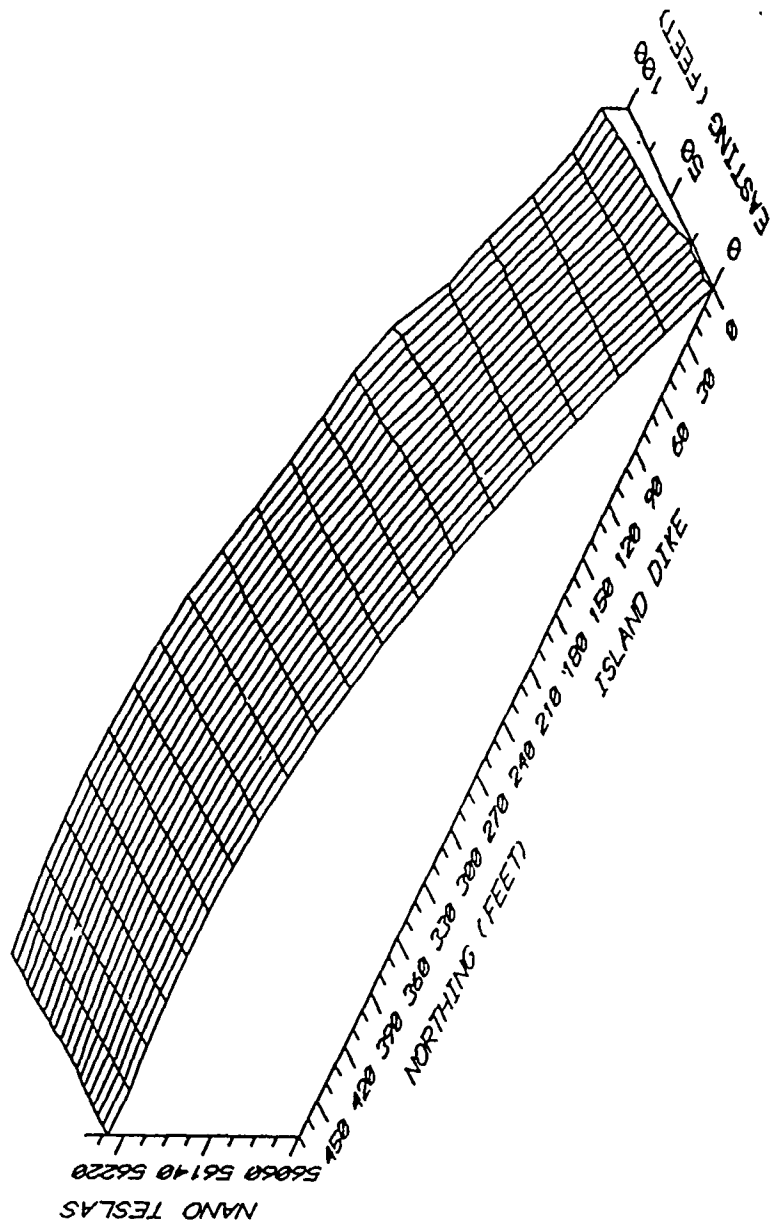
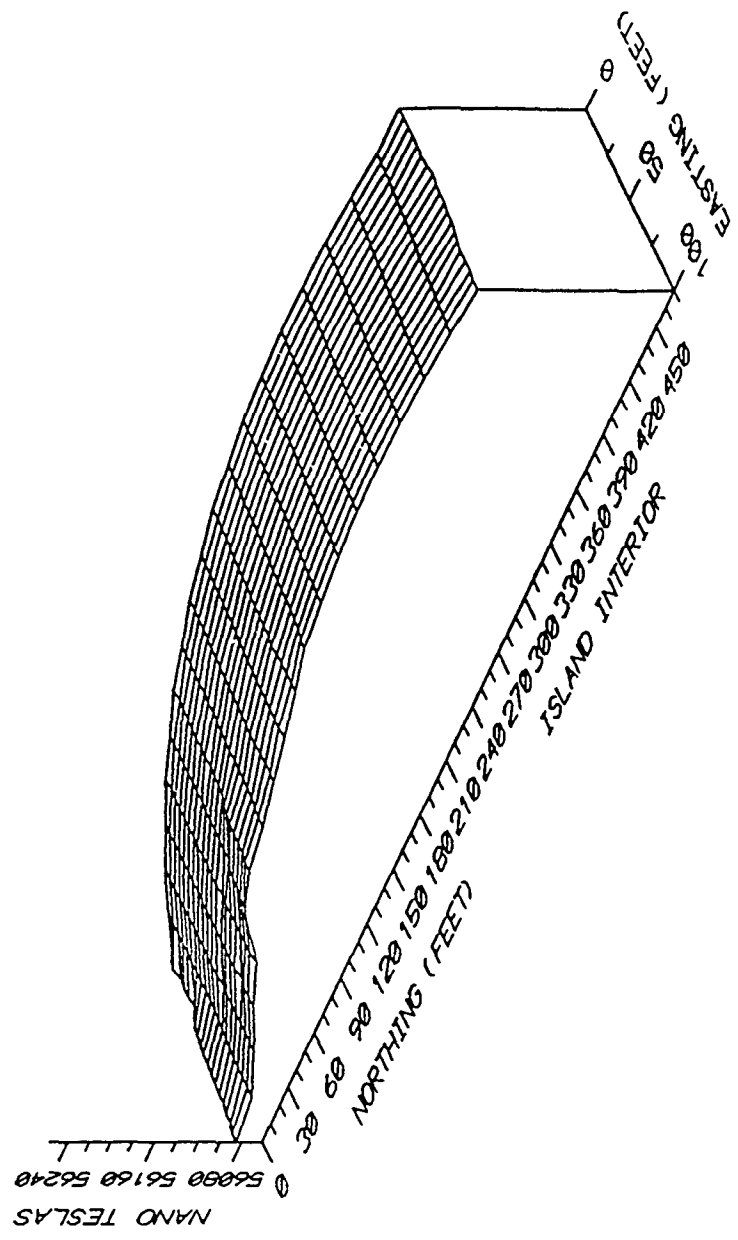
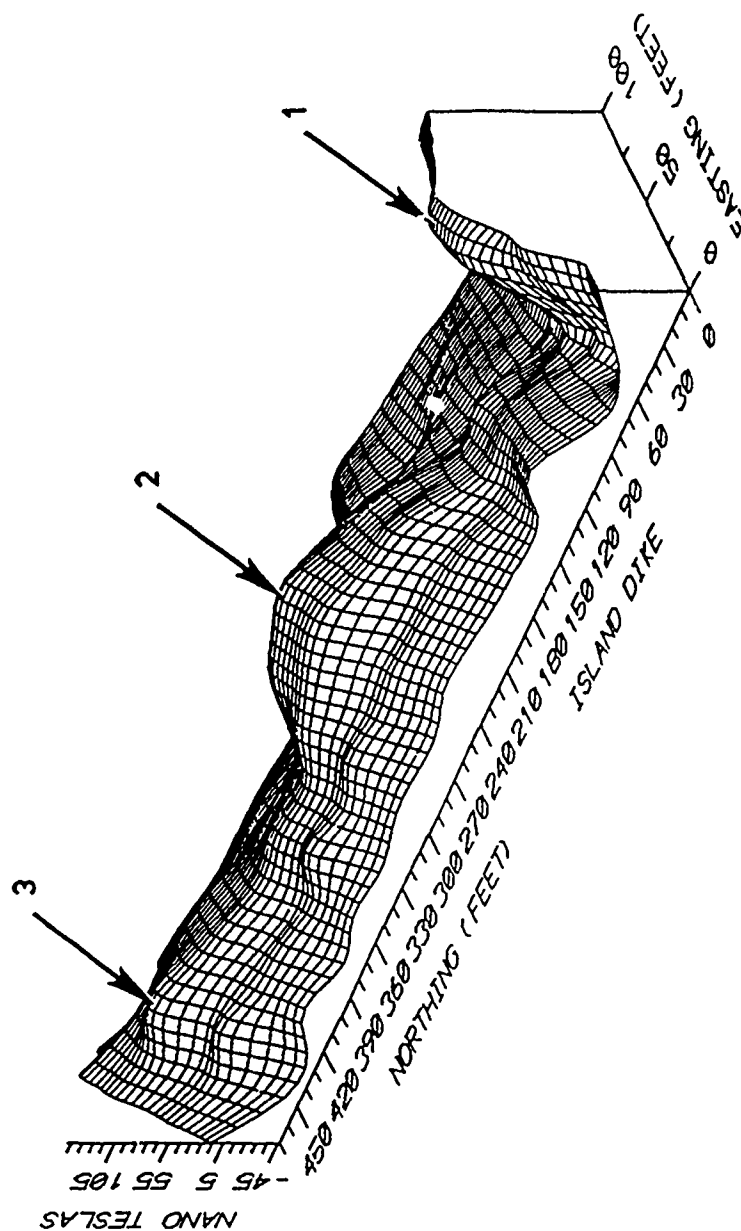

Figure 27. Eastward looking 3-D perspective of the modeled regional total magnetic field



GRMAG32, MODELED MAGNETIC FIELD

Figure 28. Westward looking 3-D perspective of the modeled regional total magnetic field



GRMRSD, RESIDUAL TOTAL MAGNETIC FIELD

Figure 29. Eastward looking 3-D perspective of the residual total magnetic field

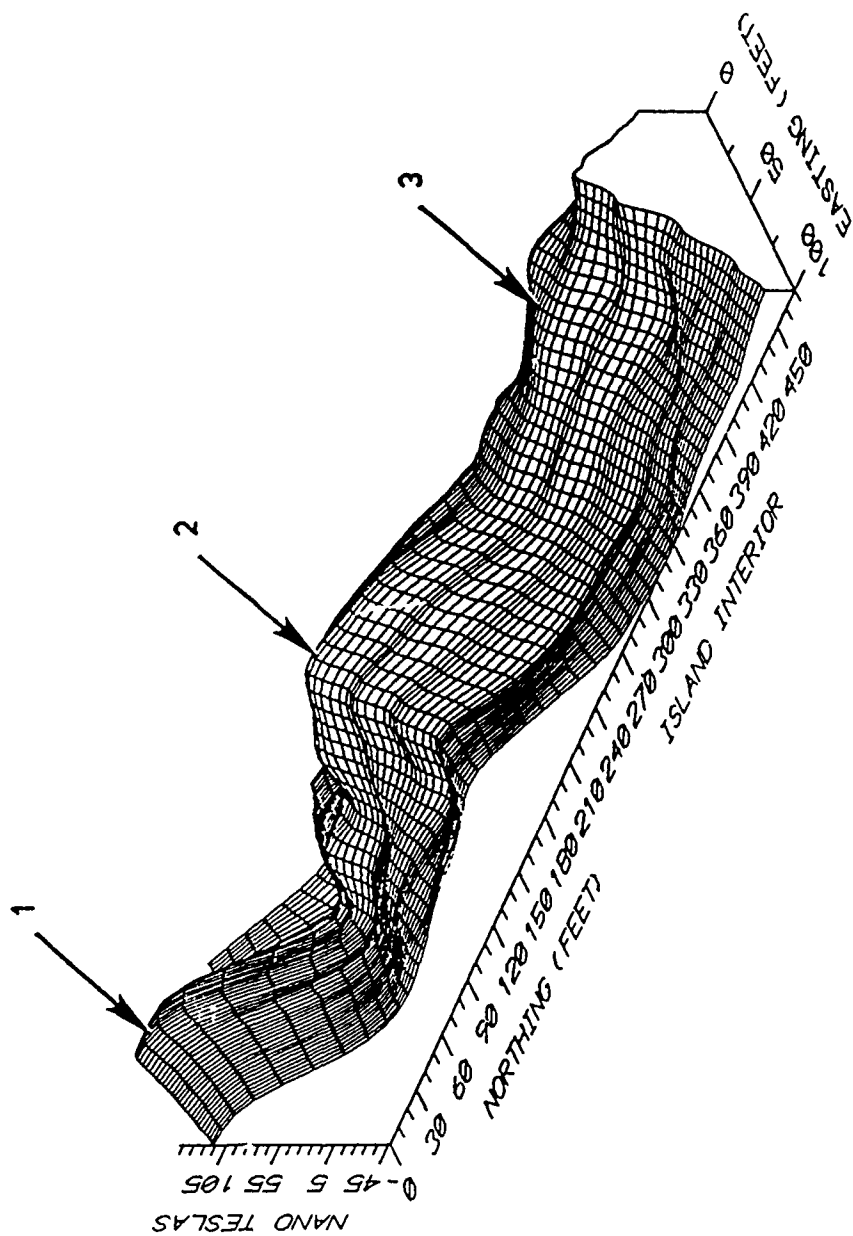

GRMRSD, RESIDUAL TOTAL MAGNETIC FIELD

Figure 30. Westward looking 3-D perspective of the residual total magnetic field