

AD-A240 926



Final Report

January 1990

①

DTIC

ELECTE

SEP 25 1991

D

EVT 10-90

MIL-STD-398 ACCEPTANCE TEST OF
AMMUNITION PECULIAR EQUIPMENT

(APE) 2245

MORTAR DISASSEMBLY/ASSEMBLY
MACHINE

This report has been approved
for release and sale; its
distribution is unlimited.

Distribution Unlimited

Prepared For:

U.S. Army Defense Ammunition

Center and School

ATTN: SMCAC-DEN

Savanna, IL 61074-9639

91-11391



9 1 24

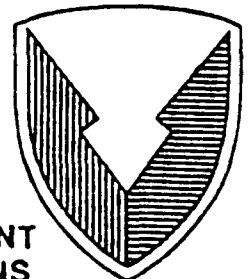

047
US ARMY
ARMAMENT
MUNITIONS
CHEMICAL COMMAND

US ARMY DEFENSE AMMUNITION
CENTER AND SCHOOL

EVALUATION DIVISION
SAVANNA, ILLINOIS 61074-9639

SECURITY CLASSIFICATION OF THIS PAGE

REPORT DOCUMENTATION PAGE

Form Approved
OMB No. 0704-0188

1a. REPORT SECURITY CLASSIFICATION UNCLASSIFIED		1b. RESTRICTIVE MARKINGS	
2a. SECURITY CLASSIFICATION AUTHORITY		3. DISTRIBUTION / AVAILABILITY OF REPORT UNLIMITED	
2b. DECLASSIFICATION / DOWNGRADING SCHEDULE			
4. PERFORMING ORGANIZATION REPORT NUMBER(S) EVT 10-90		5. MONITORING ORGANIZATION REPORT NUMBER(S)	
6a. NAME OF PERFORMING ORGANIZATION U.S. Army Defense Ammunition Center and School	6b. OFFICE SYMBOL (if applicable) SMCAC-DEV	7a. NAME OF MONITORING ORGANIZATION	
6c. ADDRESS (City, State, and ZIP Code) ATTN: SM AC-DEV Savanna, IL 61074-9639		7b. ADDRESS (City, State, and ZIP Code)	
8a. NAME OF FUNDING / SPONSORING ORGANIZATION	8b. OFFICE SYMBOL (if applicable)	9. PROCUREMENT INSTRUMENT IDENTIFICATION NUMBER	
8c. ADDRESS (City, State, and ZIP Code)		10. SOURCE OF FUNDING NUMBERS	
		PROGRAM ELEMENT NO.	PROJECT NO.
		TASK NO.	WORK UNIT ACCESSION NO.
11. TITLE (Include Security Classification) MIL-STD-398 Acceptance Test of Ammunition Peculiar Equipment (APE) Mortar Disassembly/ Assembly Machine			
12. PERSONAL AUTHOR(S) A. C. McIntosh, Jr.			
13a. TYPE OF REPORT FINAL	13b. TIME COVERED FROM _____ TO _____	14. DATE OF REPORT (Year, Month, Day) 1990 January	15. PAGE COUNT 73
16. SUPPLEMENTARY NOTATION			
17. COSATI CODES		18. SUBJECT TERMS (Continue on reverse if necessary and identify by block number)	
FIELD	GROUP	SUB-GROUP	
19. ABSTRACT (Continue on reverse if necessary and identify by block number) The U.S. Army Defense Ammunition Center and School (USADACS), Evaluation Division (SMCAC-DEV), was tasked by the Equipment Division (SMCAC-DEN) to test the Ammunition Peculiar Equipment (APE) 2245 Mortar Disassembly/Assembly Machine to MIL-STD-398, Military Standard Shields, Operational for Ammunition Operations, Criteria for Design of and Tests for Acceptance. In lieu of testing the complete APE 2245, a full scale model was used. The model was tested in accordance with Operational Shield Test Plan for APE 2245 Mortar Disassembly/Assembly Machine prepared by the Equipment Division and approved by U.S. Army Materiel Command, Field Safety Activity (AMCFSA), Charlestown IN. Thermal flux or blast overpressure amplitudes were too low to record.			
20. DISTRIBUTION / AVAILABILITY OF ABSTRACT <input checked="" type="checkbox"/> UNCLASSIFIED/UNLIMITED <input type="checkbox"/> SAME AS RPT. <input type="checkbox"/> DTIC USERS		21. ABSTRACT SECURITY CLASSIFICATION UNCLASSIFIED	
22a. NAME OF RESPONSIBLE INDIVIDUAL THOMAS J. MICHELS, Chief, Evaluation Division		22b. TELEPHONE (Include Area Code) 815-273-8928	22c. OFFICE SYMBOL SMCAC-DEV

U.S. ARMY DEFENSE AMMUNITION CENTER AND SCHOOL
Evaluation Division
Savanna, IL 61074-9639

REPORT NO. EVT 10-90

MIL-STD-398 ACCEPTANCE TEST OF
AMMUNITION PECULIAR EQUIPMENT (APE) 2245
MORTAR DISASSEMBLY/ASSEMBLY MACHINE

TABLE OF CONTENTS

PART	PAGE NO.
1. INTRODUCTION.....	1-1
A. Background.....	1-1
B. Authority.....	1-1
C. Objective.....	1-1
D. Conclusions.....	1-1
E. Recommendations.....	1-1
2. ATTENDEES.....	2-1
3. TEST PROCEDURES.....	3-1
4. TEST RESULTS.....	4-1
5. TEST PLANS.....	5-1
6. SOP.....	6-1
7. PHOTOGRAPHS.....	7-1

PART 1

INTRODUCTION

- A. BACKGROUND. The U.S. Army Defense Ammunition Center and School, Evaluation Division (SMCAC-DEV), was tasked by the Equipment Division (SMCAC-DEN) to test the APE 2245 Mortar Disassembly/Assembly Machine to MIL-STD-398, Military Standard Shields, Operational for Ammunition Operations, Criteria for Design of and Tests for Acceptance. In lieu of testing the complete APE 2245, a full scale model was used. The model was tested in accordance with Operational Shield Test Plan for APE 2245 Mortar Disassembly/Assembly Machine prepared by the Equipment Division and approved by AMCFSA, Charlestown IN.
- B. AUTHORITY. This test was conducted in accordance with mission responsibilities delegated by the U.S. Army Armament, Munitions and Chemical Command (AMCCOM), Rock Island, IL 61299-6000. Reference is made to AR-700, 15 April 1979, DARCOM Suppl 1, 4 September 1979; and AMCCOMR 10-17, 13 January 1986, Mission and Major Functions of U.S. Army Defense Ammunition Center and School.
- C. OBJECTIVE. The objective of this acceptance test is to determine if the APE 2245 satisfies the test requirements of Operational Shield Test Plan for APE 2245 Mortar Disassembly/Assembly Machine and MIL-STD-398, Military Standard Shields, Operational for Ammunition Operations, Criteria for Design of and Tests for Acceptance.
- D. CONCLUSIONS. The APE 2245, as tested by functioning three ignition cartridges with a 25 percent overload, effectively attenuated the blast overpressure and thermal flux to unrecordable levels. No fragmentation was produced as a result of the blast.
- E. RECOMMENDATION. The APE 2245, as tested, satisfied the Tests for Acceptance of MIL-STD-398.

PART 2

ATTENDEES

A.C. McIntosh, Jr.
Test Engineer
AV 585-8989
Comm 815-273-8989

Director
U.S. Army Defense Ammunition Center
and School
ATTN: SMCAC-DEV
Savanna, IL 61074-9639

Dave Valant
Electronics Technician
AV 585-8988
Comm 815-273-8988

Director
U.S. Army Defense Ammunition Center
and School
ATTN: SMCAC-DEV
Savanna, IL 61074-9639

Quinn Hartman
General Engineer
AV 585-8992
Comm 815-273-8992

Director
U.S. Army Defense Ammunition Center
and School
ATTN: SMCAC-DEV
Savanna, IL 61074-9639

Jim Hendren
Maintenance Management Specialist
AV 793-6881
Comm 309-782-6881

Commander
U.S. Army Armament, Munitions
and Chemical Command
ATTN: AMSMC-DSM-ME
Rock Island, IL 61299-6000

Robert Gruber
Engineering Technician
AV 585-8977
Comm 815-273-8977

Director
U.S. Army Defense Ammunition Center
and School
ATTN: SMCAC-DEN
Savanna, IL 61074-9639

Anthony E. King
QASAS
AV 585-8478
Comm 815-273-8478

Commander
Savanna Army Depot Activity
ATTN: SDSLE-VSR
Savanna, IL 61074-9636

Jennie K. Cliff
Munitions Handler
AV 585-8651
Comm 815-273-8651

Commander
Savanna Army Depot Activity
ATTN: SDSLE-VMO
Savanna, IL 61074-9636

Sharon Holmbo
Explosive Operator Foreman
AV 585-8651
Comm 815-273-8651

Director
Savanna Army Depot Activity
Center and School
ATTN: SDSLE-VMO
Savanna, IL 61074-9636

Stanley Holmbo
Munitions Handler
AV 585-8687
Comm 815-273-8687

Ken Proper
Safety Manager
AV 585-8976
Comm 815-273-8976

Emory Erquitt
Equipment Specialist
AV 585-8907
Comm 815-273-8907

CPT Michael Demcko
Mission Division
AV 585-8631
Comm 815-273-8631

Commander
Savanna Army Depot Activity
ATTN: SDSLE-VMO
Savanna, IL 61074-9636

Commander
U.S. Army Defense Ammunition Center
and School
ATTN: SMCAC-SF
Savanna, IL 61074-9639

Director
U.S. Army Defense Ammunition Center
and School
ATTN: SMCAC-DEV
Savanna, IL 61074-9639

Commander
Savanna Army Depot Activity
ATTN: SDSLE-VM
Savanna, IL 61074-9636

PART 3

TEST PROCEDURES

DETAILED REQUIREMENTS

100 Class- Blast Attenuation Tests

200 Class - Fragmentation Confinement Tests

300 Class - Thermal Effects Attenuation Tests

CLASS-100 BLAST ATTENUATION TESTS

METHOD 101

BLAST OVERPRESSURE MEASUREMENT

1. PURPOSE

a. Measurement of blast overpressure is conducted to ensure that personnel are not exposed to peak positive incident overpressure greater than 2.3 psi when the operational shield is subjected to a maximum credible incident (MCI).

b. An acceptable alternative to measuring peak positive incident overpressure is to measure peak positive normal reflected overpressure. Personnel shall not be exposed to a maximum positive normal reflected overpressure greater than 5.0 psi when the operational shield is subjected to an MCI.

2. DESCRIPTION OF TEST

An MCI is created with the operational shield. Blast pressure gages are used to measure blast overpressure.

3. CRITERIA FOR PASSING TEST

The operational shield shall be considered acceptable if it can be determined from a pressure-distance plot of the data that personnel will not be exposed to a peak positive incident overpressure above 2.3 psi or a peak positive normal reflected overpressure above 5.0 psi.

4. INSTRUMENTATION

Blast Pressure Gages and Electronic Recording System. Based on the equivalent test charge weight of explosives and anticipated peak overpressure, the instrumentation system shall have the necessary response time and

band width to acquire data. Instrumentation shall be calibrated in accordance with current procedures of TB 43-180, Calibration Requirements for the Maintenance of Army Materiel.

5. TEST PROCEDURE

a. When the shield is tested in a simulated operational bay environment, overpressure readings shall be taken at the following locations:

(1) At the center of probable head locations of each operator. For standing locations, the gages shall be positioned 65 inches above the floor; for sitting locations, it shall be 31.5 inches above the seat.

(2) At representative positions where transient personnel may be located.

b. When testing is conducted in open air, position blast gages around the shield in two or three concentric circles at distances where it is expected that overpressures of interest will be found. Stagger the gages so shock waves reaching the outer circles are not distorted by gages in the inner circle. The gages shall be placed at a height of 65 inches.

c. All instrumentation shall be within calibration at time of test.

d. If the shield is designed for use with more than one model or type of ammunition, select the item that would produce the maximum overpressure.

e. Apply an overload equal to 25 percent or more of the filler weight of the ammunition selected for the test, unless otherwise directed in an approved test plan.

f. All major explosive components should be fused separately to ensure simultaneous detonation or deflagration in order to simulate the MCI, unless otherwise directed in an approved test plan.

g. Function explosives and record overpressure readings.

h. Prepare pressure-distance plots from overpressure recordings.

CLASS-200 FRAGMENT RETENTION TESTS

METHOD 201

FRAGMENT RETENTION TEST

1. PURPOSE

Fragment testing is conducted to verify that a prototype operational shield will:

- a. Contain all fragmentation or direct fragmentation away from areas requiring protection.
- b. Prevent generation of secondary fragmentation within areas requiring protection.
- c. Prevent movement, overturning, or structural deflections which could result in personal injury.

2. DESCRIPTION OF TEST

An MCI is created to test the operational shield.

3. CRITERIA FOR PASSING TEST

- a. Contain all fragmentation or direct fragmentation away from areas requiring protection.
- b. Prevent generation of secondary fragmentation within areas requiring protection.
- c. Prevent movement, overturning, or structural deflections which could result in personal injury.

4. TEST EQUIPMENT

Still picture camera equipment.

5. TEST PROCEDURE

- a. Fragmentation Retention Test.

(1) If the shield is designed for use with more than one mode or type of ammunition, select that item which will have the greatest potential fragmentation or shape charge effect. Equipment, or reasonable simulation

thereof, which shall perform the intended function on the ammunition, shall be positioned to generate secondary fragments.

(2) Apply an overload equal to 25 percent or more of the filler weight of the ammunition selected for the test, unless otherwise directed in an approved test plan.

(3) All major explosive components should be fused separately to ensure simultaneous detonation or deflagration in order to simulate the MCI, unless otherwise directed in the approved test plan.

(4) Function explosives.

b. Post-Test Procedure.

(1) Examine the interior and exterior for evidence of fragments. Photograph the shield to document test results.

(2) Examine shield for movement, overturning, or structural deflections which could result in personal injury.

(3) Shields designed for intentional detonation shall be examined for damage and an estimate made as to the ability of the shield to remain operational as specified in the design criteria.

CLASS-300 THERMAL EFFECTS MEASUREMENT

METHOD 301

HEAT FLUX MEASUREMENT

1. PURPOSE

Heat flux measurement is a condition of measure that personnel are not exposed to a maximum radiant heat flux determined in the equation given in criteria for passing test of this standard.

2. DESCRIPTION OF TEST

An MCI is created. Heat flux transducers are used to measure radiant heat flux.

3. CRITERIA FOR PASSING TEST

The operational shield shall be considered acceptable if it can be determined from heat flux-distance and heat flux-time plots of test data that personnel will not be exposed to a radiant heat flux rating exceeding the formula: $F=1.0/(0.62t) T=0.7423 \text{ cal/cm}^2\text{-sec}$, where F= is the thermal flux, T=time in seconds.

4. INSTRUMENTATION

Heat Flux Transducers and Electronic Recording System. Based on the thermal flux expected at the location of the transducers, the instrumentation system shall have the necessary response time and bandwidth to acquire data. Instrumentation shall be calibrated in accordance with current procedures of TB 43-180, Calibration Requirements for the Maintenance of Army Materiel.

5. TEST PROCEDURE

a. When the shield is tested in a simulated operational bay environment, heat flux readings shall be taken at the following locations:

(1) At the center of probable head locations of each operator. For standing locations the transducers shall be positioned 65 inches above the

floor; for sitting locations it shall be 31.5 inches above the seat.

(2) At representative positions where transient personnel may be located.

b. In a free field test, flux values at various distances from the point of detonation can be estimated by the relationship: $O_1 \cdot (d_1^2) = O_2 \cdot (d_2^2)$, where O =heat flux in $\text{btu/in}^2\text{-sec}$ d =distance from point of detonation.

c. All instrumentation shall be within calibration at time of test.

d. If the shield is designed for use with more than one model or type of ammunition, select the item for the greatest heat flux.

e. Apply an overload equal to 25 percent or more of the filler weight of the ammunition selected for the test, unless otherwise directed in an approved test plan.

f. All major explosive components should be fuzed separately to ensure simultaneous detonation or deflagration in order to simulate the MCI, unless otherwise directed in an approved test plan.

g. Function explosives and record radiant flux readings.

h. Prepare heat flux-distance and heat flux-time plots from radiant flux recordings.

PART 4
TEST RESULTS

CLASS 100 - BLAST ATTENUATION TESTS

Peak blast overpressures were too low to be recorded by the calibrated gages.

CLASS 200 - FRAGMENTATION CONFINEMENT TESTS

No primary or secondary fragmentation was produced from functioning three ignition cartridges in the test fixture.

CLASS 300 - THERMAL EFFECTS ATTENUATION TESTS

Thermal flux amplitudes were low level. As a result, no thermal flux was recorded.

ADJACENT SYMPATHETIC FUNCTIONING

Two adjacent ignition cartridges, placed in simulated adjacent cells, did not function.

PART 5
TEST PLANS

OPERATIONAL SHIELD TEST PLAN

FOR

**AMMUNITION PECULIAR EQUIPMENT (APE) 2245
MORTAR DISASSEMBLY/ASSEMBLY MACHINE**

DEVELOPED BY THE

EQUIPMENT DIVISION

OF THE

U.S. ARMY DEFENSE AMMUNITION CENTER AND SCHOOL

AUGUST 1989

OPERATIONAL SHIELD TEST PLAN

FOR

AMMUNITION PECULIAR EQUIPMENT 2245 MORTAR DISASSEMBLY/ASSEMBLY MACHINE

1. SCOPE: This test plan is to establish the testing procedures, methods and acceptance criteria utilized to validate that the level of protection provided by the Ammunition Peculiar Equipment (APE) 2245, Mortar Disassembly/Assembly machine, meets or exceeds the requirements of MIL-STD-398, Shields, Operational For Ammunition Operations, Criteria For Design Of And Tests For Acceptance.

2. PURPOSE: The purpose of this Operation Shield Testing is to certify that an operator occupying in an individual working cell of the APE 2245 and a transient standing behind the operator are shielded from an incident occurring in an adjacent working cell. It is not a requirement of this test nor the APEs design to provide any level of shielding to the operator or transients in the cell where the incident occurs.

3. APE 2234 BACKGROUND:

3.1. Purpose: The APE 2245 is being fielded to increase the level of safety and production rate of mortar renovation operations. The APE 1148 previously used for large scale maintenance operations will return to being a Surveillance fixture. The underlying safety principle being employed is to constrain the mortar through the total renovation process to reduce the probability of an incident during removal and replacement in various holding fixtures or transportation from one operation to the next.

3.2. Description: The APE 2245, Figure 1, is a six-cell machine for renovation of the aft-end of 60mm and 81mm mortar ammunition. Each cell provides for one operator to perform a single function or a series of related functions on the mortar being renovated. This multi-cell concept allows the mortar to be locked into a holding fixture and rotated in the fixture from one operation to the next on a carousel-type table. The APE 2245 can be used to replace ignition cartridges, primers, and fin assemblies singularly, or in varying combinations, depending upon operational requirements.

The APE 2245 consists of six work cells separated from each other by side walls constructed of clear polycarbonate (Relaxing).

The carousel which transports the secured mortar from one operation to the next also has sidewalls of clear polycarbonate which interlock with the cell's sidewalls to form a solid wall or shield.

3.3. Test Configuration: Shield testing will be conducted on a single work cell consisting of two side shields and a top shield. Due to costs involved, no functional equipment will be used in the test, but the physical size, construction, and layout of various equipment will be duplicated to simulate their vulnerability to the explosive incident; this will include simulation of hydraulic lines and cylinders loaded with fluid, located on the inside of the machine.

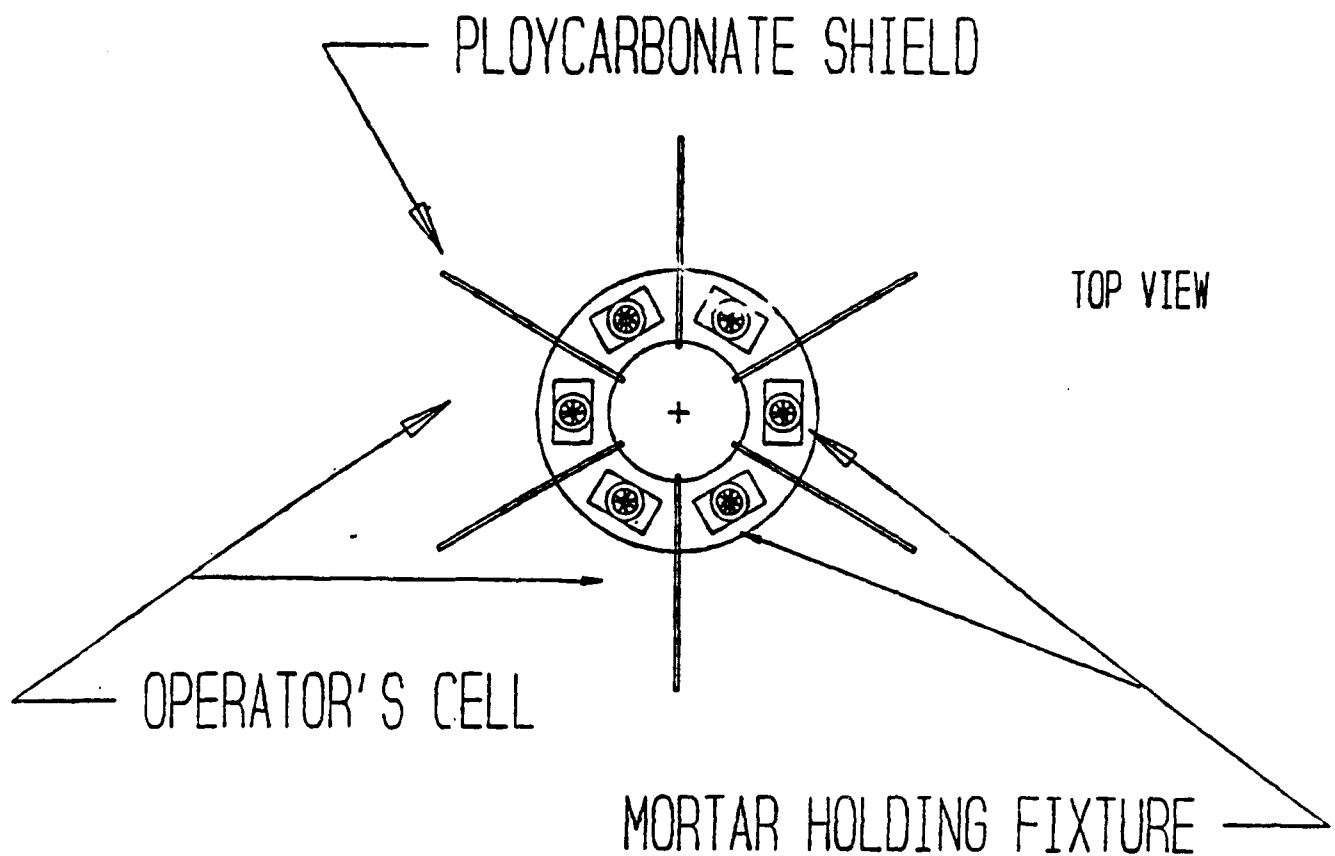

FIGURE 1

APE 2245

MORTAR DISASSEMBLY/ASSEMBLY MACHINE

4. MAXIMUM CREDIBLE INCIDENT:

4.1. Definition: The Maximum Credible Incident (MCI) for the Operational Shield Test of APE 2245 shall be defined as the functioning of the electric squib, substituted for the percussion primer, 123 grains of M9 propellant loaded in an ignition cartridge to represent the effects of the M6 or M8 Ignition Cartridge, and a 25 percent overload of 31 grains of M9 Propellant. The electric squib, ignition cartridge and 25 percent overload of propellant shall be configured in an inert M374 series round, 1315-C256. Functioning shall be defined as deflagration of the propellant. No detonation of any propellant or high explosive (HE) is required to validate the level of operator protection.

4.2. Rationale For MCI: The following rationale is provided for selection of the MCI.

4.2.1. One hundred twenty three grains of M9 propellant was selected to represent the most potent ignition cartridge currently used in 60mm, 81mm and 4.2-inch rounds. By qualifying the APE 2245 for 123 grains of M9 Propellant, the APE 2245 would be automatically qualified for any amount of M9 or equivalent propellant not exceeding 123 grains. Table I, Mortar Ignition Cartridges, contains a listing of fielded ignition cartridges.

4.2.2. During use of the round in the field, the HE charge or other payload does not function when the primer or ignition cartridge is functioned.

4.2.3. The HE charge or other payload only functions under certain conditions which vary depending upon the type of fuze which is incorporated into the round.

4.2.4. Each fuze is designed with certain safeties which preclude accidental functioning of the fuze until intentionally armed.

4.2.5. Each of the various APE 2245 mortar holding fixtures will be designed to provide the maximum protection possible to the safeties of the mortar being renovated.

4.2.6. Each of the various APE 2245 mortar holding fixtures will be designed to prohibit motion of the mortar during accidental function of the primer and mortar ignition cartridge.

TABLE I
MORTAR IGNITION CARTRIDGES

IGNITION CARTRIDGE	DRAWING *	GRAINS POWDER
M2A2	9252205	170 BLACK POWDER
M6	8865062	123 M9
M8	8865089	123 M9
M3	75-19-76	120 MORTAR TRENCH PROP.
M2 series	8797831	120 M9
M299	9293422	115 M9
M4	unknown	Obsolete
M100	P109354	Obsolete
M66	8837347	115 M9
M66A1	8837347	115 M9
M285	9240960	108 M9
M702	9280553	60 M9
M5A1/A2	9242127	40 M9
L33A1	GD/030/200777	British Round - No Data Available

The M3 Ignition is used in only one round, the 81mm M68 Training Cartridge. Additionally, the M6 Ignition Cartridge may be substituted for the M3 Ignition Cartridge. Therefore, their power characteristics must be identical. Based on this relationship and lack of information on Mortar Trench Propellant, it was resolved that Mortar Trench Propellant is equivalent to M9 propellant.

Based on the results of the Brisance Sand Test, it was determined that the M9 was about six times more powerful than black powder. Therefore, 123 grains of M9 represented the most potent ignition cartridge.

Black Powder Brisance Sand Test 8 grms

M9 -

57% Nitrocellulose Brisance Sand Test 48 grams
40% Nitroglycerin Brisance Sand Test 51.5 grams

5. OPERATIONAL SHIELD TEST METHODS: The following test methods of MIL-STD-398 shall be used:

- a. Method 101, Blast Overpressure Measurement;
- b. Method 201, Fragment Retention Test;
- c. Method 301, Heat Flux Measurement.

6. ACCEPTANCE CRITERIA: The APE 2245 shall qualify as an operational shield by meeting or exceeding all of the following criteria. Compliance shall be determined according to the applicable test methods of MIL-STD-398 as stated above unless otherwise noted.

6.1. Blast Attenuation: The shield between work cells shall prevent peak positive incident pressures from exceeding 2.3 psi (16 kN/m²) in either work cell adjacent to the cell where the functioning occurred.

6.2. Noise Attenuation: No noise attenuation is required since operation requirements preclude the intentional functioning of ignition cartridges or primers.

6.3. Fragmentation Confinement: No primary or secondary fragmentation shall enter either adjacent work cell due to the MCI in the middle cell.

6.4. Thermal Effects Attenuation:

6.4.1. Heat Flux Attenuation: The shield between work cells shall limit heat flux exposure to personnel as defined by paragraph 4.1.3 of MIL-STD 398.

6.4.2. Attenuation of Visible Fire or Flame:

6.4.2.1. Upper Torso Protection: The shield between cells shall protect the upper torso of the operator and transients in the adjacent cell from visible flame or fire produced in the cell where the ignition cartridge is functioned.

6.4.2.2. Lower Torso Protection: The shield between cells does not have to protect the lower torso of the operator and transients in the adjacent cell from visible flame or fire produced in the cell where the ignition cartridge is functioned, provided that the heat flux specified above is not exceeded.

6.5. Asset Protection: No asset protection is required by the shields separating cells.

6.6. Mortar Propagation: The shield shall prevent propagation of mortar ignition cartridges located in adjacent cells. This shall be determined by whether or not functioning of the MCI causes functioning of mortar ignition cartridges placed to simulate one each in adjacent work cells.

6.7. Mortar Motion: The APE 2245 mortar holding fixture shall limit the vertical motion due to the MCI to 1/4 inch or less. This will be determined by measuring from the carousel table surface to the top of the fin assembly of the complete round before and after the test.

7. Test Location: The operational shield test will be conducted with the APE 2245 in building 628, while building 626 will be used to as the remote site for activation of the mortar ignition cartridge.

8. TEST CONFIGURATION:

8.1. APE 2245 Configuration: The APE 2245 shall be setup in the test bay according to Figure 2, Simulated APE 2245 Setup. After completion of firing two rounds, the APE 2245 will be rotated 90 degrees to orient the MCI cell adjacent to the back wall. All instrumentation, except cameras, will reposition.

8.2. Instrumentation:

8.2.1. MCI Cell: No instrumentation is required in this cell since no level of protection is required.

8.2.2. Adjacent Cells: Pressure transducers and heat flux instrumentation shall be positioned according to Figure 3, Test Instrumentation Setup.

8.2.3. High-Speed Motion Picture Camera: A high-speed motion picture camera shall be position as shown on Figure 4, Facility Layout.

8.2.4. Video Recorder: A video camera shall be position as shown on Figure 4, Facility Layout.

8.2.5. Recording Instruments: Recording instruments shall be positioned as indicated on Figure 4, Facility Layout.

8.3. Mortar Round: The mortar round shall be secured in a fixture of the APE 2245, according to Figure 5, Mortar Holding Fixture.

8.4. Adjacent Mortar Ignition Cartridges: Position two mortar ignition cartridges with fin assemblies on specially constructed stands as shown in Figure 6, Adjacent Ignition Cartridge Setup.

9. TEST PROCEDURE: The following steps outline the general procedures that will be used to test the APE 2245. Specific steps will be contained in an SOP developed especially for this test.

9.1. The simulated cell of the APE 2245 with be setup in Bay G of building 628 according to Figure 1, Simulated APE 2245 Setup.

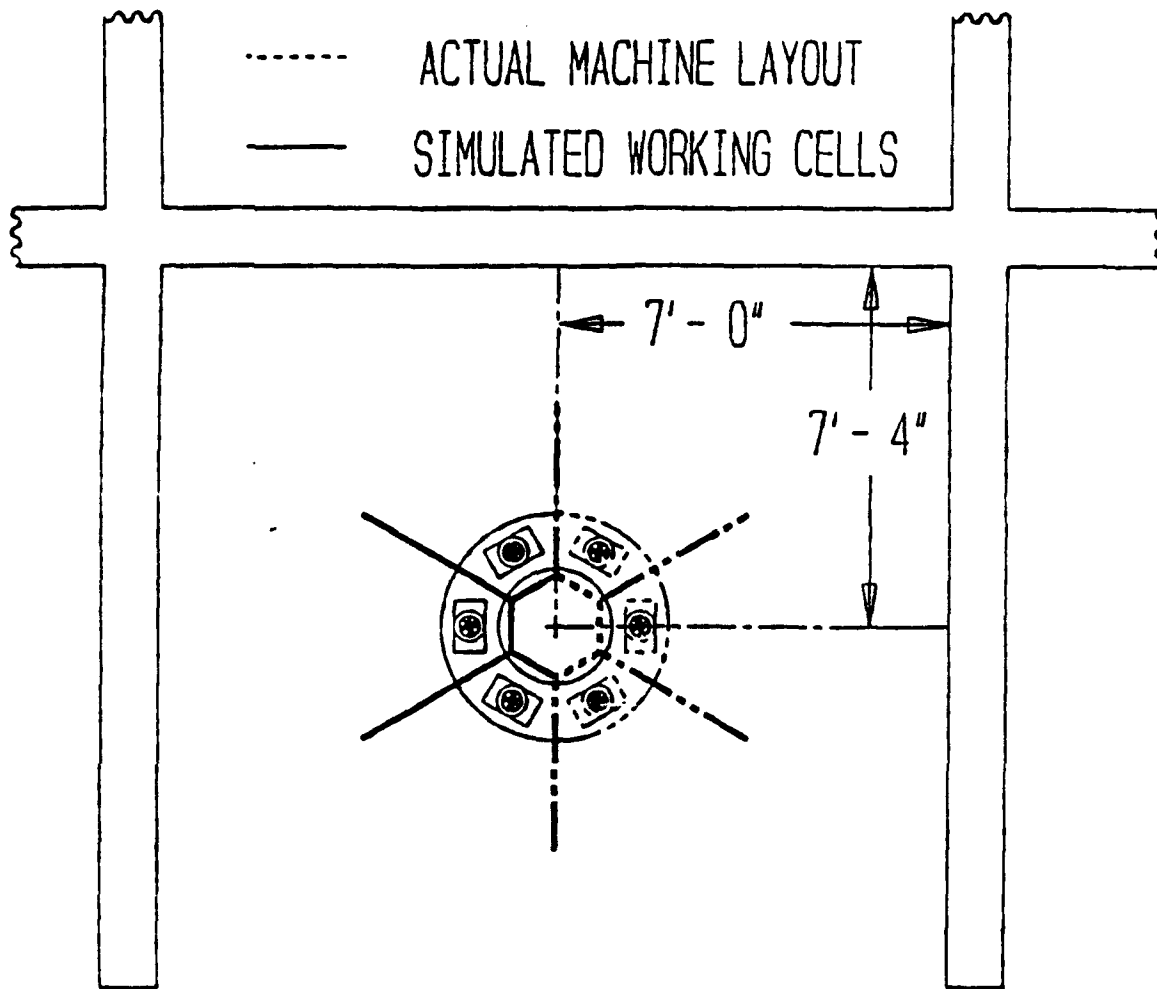

Figure 2
 SIMULATED APE 2245 SET UP

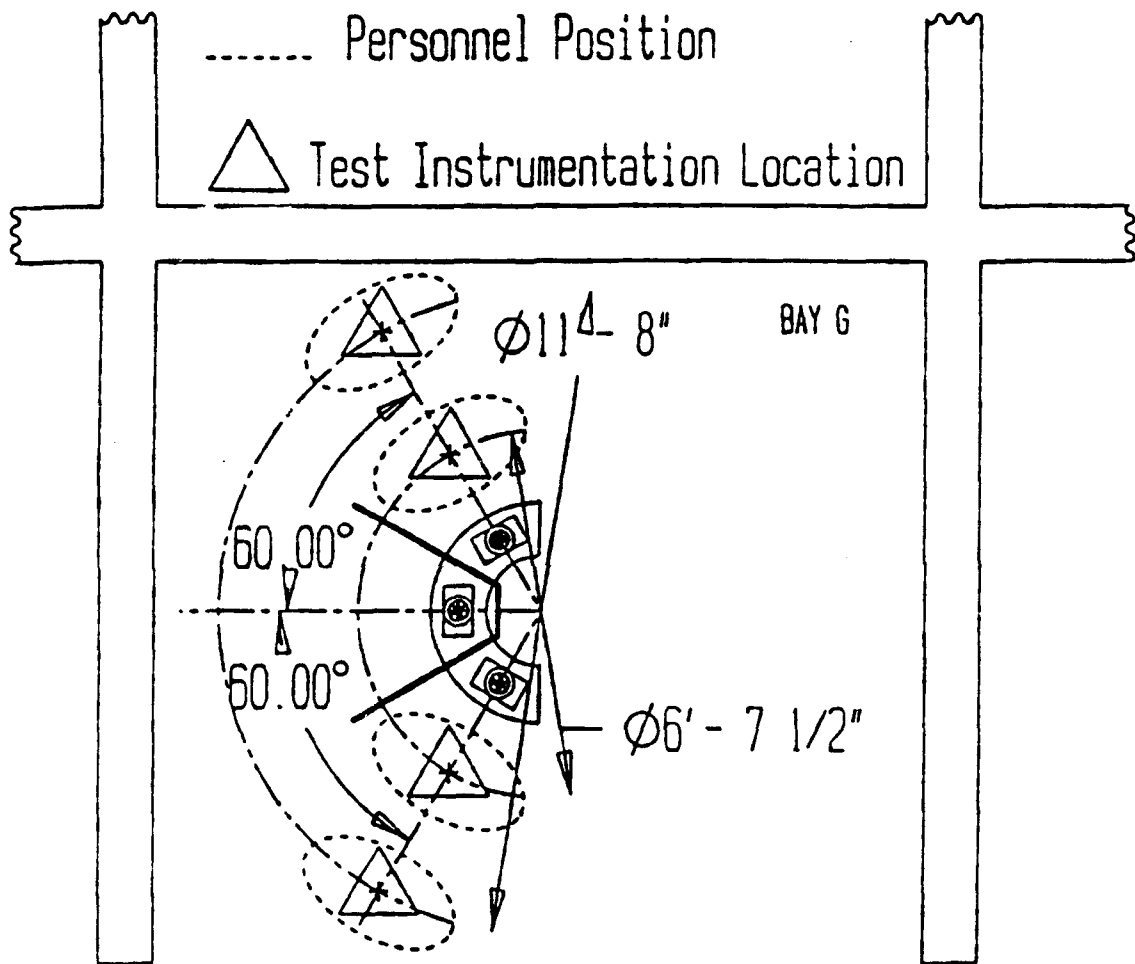
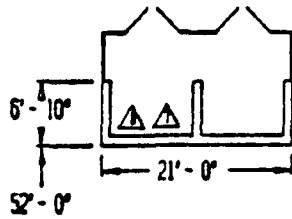

FIGURE 3
TEST INSTRUMENTATION SET UP

BUILDING 626

BUILDING 626 WAS DESIGNED AS A BARRICADE FOR THE BUILDING VACUUM SYSTEM. THE ROOF, THE SOUTH WALL, CENTER WALL AND BOTH END WALLS ARE REINFORCED CONCRETE. THE FRONT PORTION OF THIS BUILDING IS CONSTRUCTED WITH COVERED CORR ASBESTOS.

BUILDING 626



- △ Instrumentation Van
- △ Simulated APE 2245
- △ Side-On Pressure Transducers
- △ Heat Flux Instruments
- △ High Speed Camera
- △ Television Camera
- △ Television Monitor
- △ APE 1963

BUILDING 628

THE INTERIOR WALLS ARE 12 INCH REINFORCED CONCRETE. THE OUTER WALLS ARE HOLLOW TILE. THE ROOF IS 7/16 CORR ASBESTOS. THE CORR ASBESTOS ROOF OVER BAY G HAS BEEN REPLACED WITH FIBERGLAS PANELS. THE RAMPS LOCATED ON NORTH AND SOUTH SIDES OF BUILDING ARE ENCLOSED WITH CONCRETE BLOCKS.

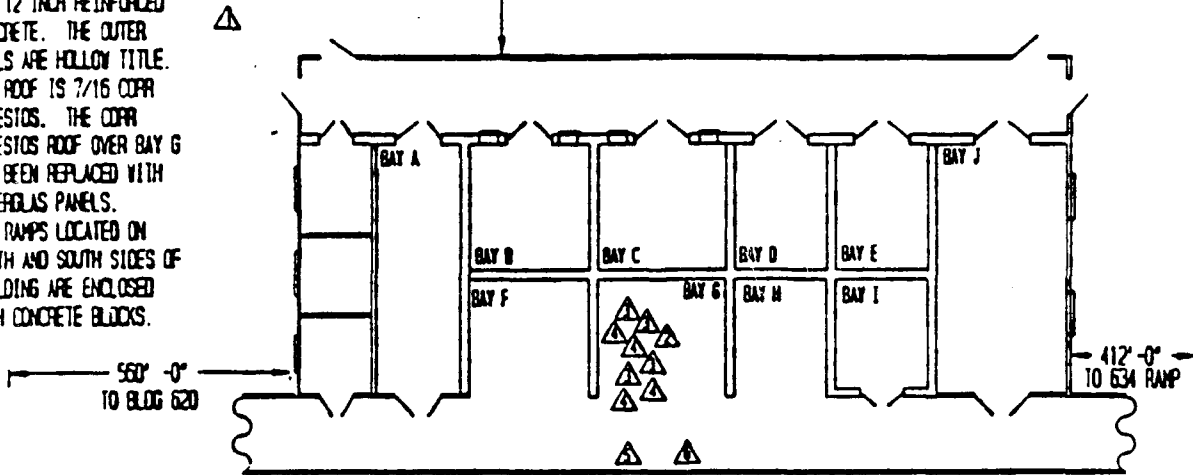

BUILDING 628

**FIGURE 4
FACILITY LAYOUT**

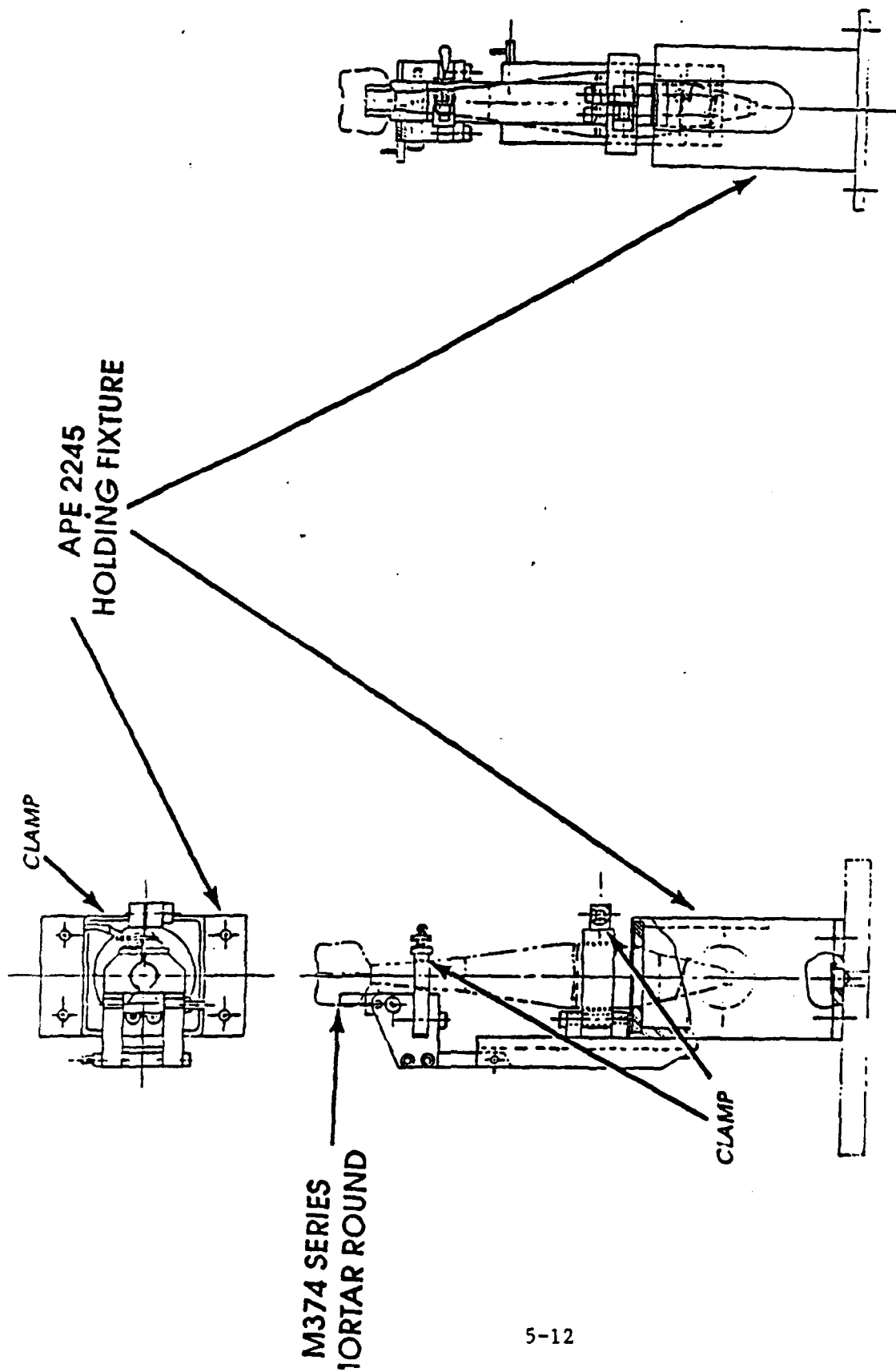

FIGURE 5
MORTAR HOLDING FIXTURE

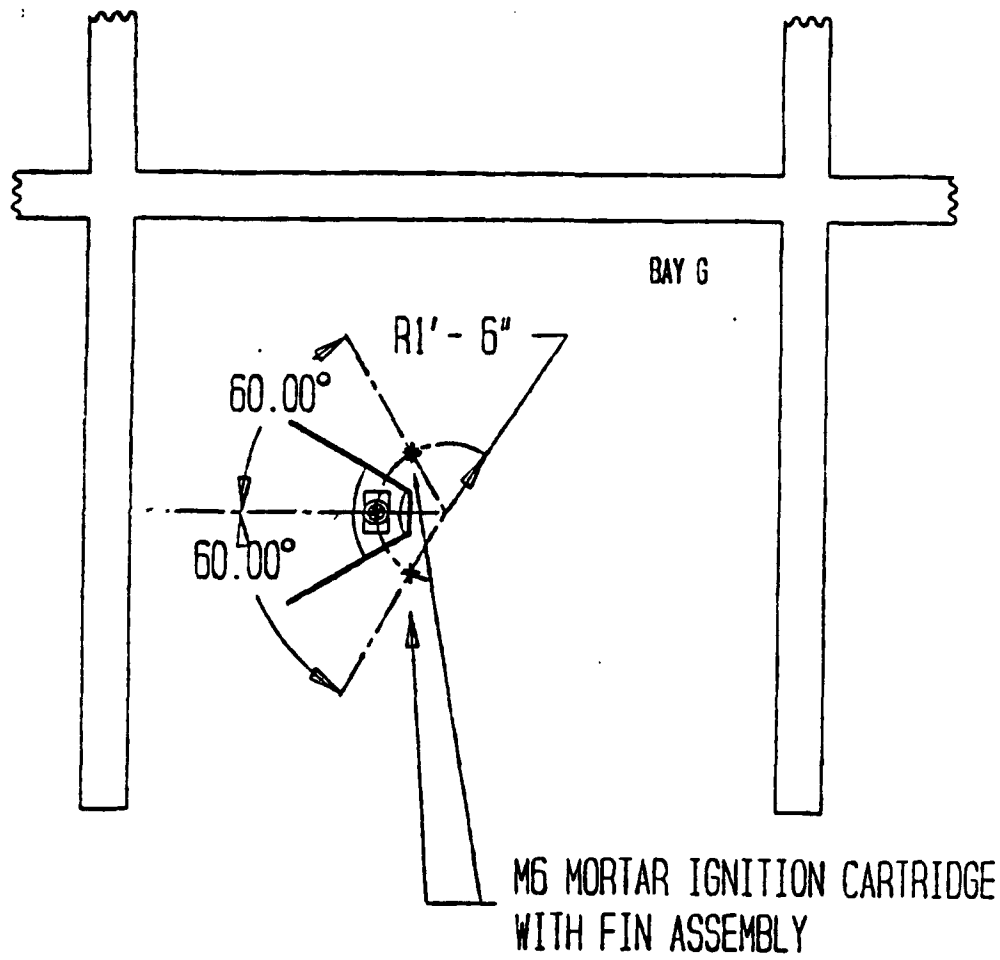

FIGURE 6
ADJACENT IGNITION CARTRIDGE SETUP

9.2. Test instrumentation will be setup according to Figure 2, Test Instrumentation.

9.3. The mortar ignition cartridge will be loaded with a 25 percent overcharge.

9.4. The explosive items will be received and stored in Bay I of building 628.

9.5. The firing lines from Bay G of building 628 to building 626 will be checked for continuity and stray currents.

9.6. All personnel except for the explosive operator, test engineer, project engineer and surveillance personnel will evacuate building 628 for building 626.

9.7. The first mortar round will be removed from Bay I and placed in the fixture of the APE 2245 in Bay G.

9.8. The firing leads will be taken to Bay I and connected to the firing cables going to building 626.

9.9. All personnel will leave building 628 for building 626.

9.10. All test instrumentation will be activated remotely.

9.11. The firing cables will be connected to a firing device and the mortar round activated.

9.12. Personnel will return to Bay G of building 618 when it has been determined by the test engineer and surveillance personnel that no danger is present.

9.13. If no damage to the APE 2245 is observed, the test will be repeated for an additional mortar round.

10. TESTING RESPONSIBILITY: The USADACS Evaluation Division, SMCAC-DEV, shall setup, conduct, and document the operational shield testing according to this test plan. SMCAC-DEV will be responsible to interpret the test results and write the test report based on the criteria established by this test plan.

11. TEST DOCUMENTATION: The following documentation shall be collected and included in or with the test report:

- a. Drawings showing location of the simulated APE 2245 and all instrumentation;
- b. All recorded test data;
- c. Still camera color pictures showing equipment and instrumentation prior to and after testing;
- d. At least one high-speed color motion picture film of each shield test. Events shall be recorded at the highest speed permitted by prevailing light conditions;
- e. A video tape of each test;
- f. Other data, as required, to illustrate or clarify the test setup, conclusions or recommendations.

12. TEST REPORT:

12.1. Test Report Format: A test report will developed to meet the criteria of paragraph 4.3.2, page 8, of MIL-STD-398.

12.2. Test Conclusions and Recommendations: All conclusions and recommendations in the test report will be supported by documentation.

12.3. Final Test Report: A final test report for the operational shield shall be prepared and forwarded to SMCAC-DEN no later than 90 days after conclusion of testing.

PART 6

SOP

1. U.S. Army Defense Ammunition Center and School

STANDING OPERATING PROCEDURE FOR:

- | | | |
|----------|--|---|
| 2. ITEM: | a. <u>Downloaded, CTG,</u>
<u>81mm HE</u>
<u>M374 Series</u> | 3. OPERATION <u>Engineering Test of APE 2245</u> |
| | b. <u>1315-C256</u> | 4. ESTIMATED DAILY PRODUCTION RATE <u>N/A</u> |
| | c. <u>Packaged 1.4,</u>
<u>Fire Symbol 4</u> | 5. ORGANIZATION SYMBOL <u>SMCAC-DEV</u> |
| | d. <u>Unpackaged 1.4,</u>
<u>Fire Symbol 4</u> | 6. SOP No. <u>AC-C256-M-014</u> DATE <u>11 JAN 1990</u> |
| | e. <u>Chemical Hazard</u>
<u>Symbol - None</u> | a. Rev No. _____ DATE _____ |
| | | b. Change No. _____ DATE _____ |
| | | 7. AUTHORITY <u>AR 700-20</u> DATE <u>15 Apr 79</u> |

8. PREPARED BY *Emory G. Emmitt* DATE 9 JAN 90 TITLE Equipment Specialist
EMORY G. EMMITT PHONE: AUTOVON 585-8907
9. REVIEWED BY *R. A. Green* DATE 9/Jan 90 TITLE Chief, Equipment Div
RICHARD A. GREEN
10. SUBMITTED BY *Thomas J. Michels* DATE 9 JAN 90 TITLE Chief, Evaluation Div
THOMAS J. MICHELS

11. CONCURRENCES:

OFFICE	SIGNATURE/DATE	TITLE
<u>LOGISTICS ENGINEERING OFC</u>	<u><i>William F Ernst</i></u> <u>9 JAN 90</u> <small>WILLIAM F. ERNST</small>	<u>Chief, Logistics Engr Dfc</u>
<u>LOGISTICS REV & ASST OFC</u>	<u><i>Thomas F. Lighthiser</i></u> <u>9 JAN 90</u> <small>THOMAS F. LIGHTHISER</small>	<u>Chief, Rev & Assistance Ofc</u>
<u>FIRE PREV & PROT BRANCH</u>	<u><i>Bernard G. Mix</i></u> <u>10 JAN 90</u> <small>BERNARD G. MIX</small>	<u>Chief, Fire Prev & Prot Branch</u>
<u>SECURITY BRANCH</u>	<u><i>James P. Moore</i></u> <u>10 Jan 90</u> <small>JAMES P. MOORE</small>	<u>Security Officer</u>
<u>MISSION DIVISION</u>	<u><i>Michael A. Demcko</i></u> <u>9 Jan 90</u> <small>CPT MICHAEL A. DEMCKO</small>	<u>Chief, Mission Division</u>
<u>QUALITY ASSURANCE DIVISION</u>	<u><i>Darryl D. Blumenshein</i></u> <u>9 Jan 90</u> <small>DARRYL D. BLUMENSHEIN</small>	<u>Chief, Quality Assurance Dvs</u>
<u>ENVIRONMENTAL</u>	<u><i>John E. Clarke</i></u> <u>9-Jan-90</u> <small>JOHN E. CLARKE</small>	<u>Environmental Coordinator</u>
<u>SAFETY</u>	<u><i>Kenneth W. Proffer</i></u> <u>9 Jan 90</u> <small>KENNETH W. PROFFER</small>	<u>Safety Manager</u>

12. APPROVAL:

DATE:

DATE:



JOHN L. BYRD, JR.
Director
Defense Ammunition Center & School

11 JAN 1990

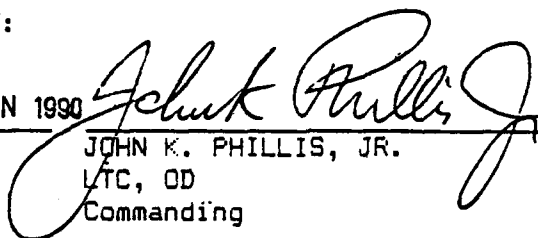

JOHN K. PHILLIS, JR.
LTC, OD
Commanding

1/11/90

OPERATOR'S STATEMENT

SOP No. AC-C256-M-014 REV No. _____ CHANGE No. _____ DATE 11 JAN 1960

1. The operator will sign this statement:
 - a. When first assigned to the operation.
 - b. When an approved formal or interim change is made to the SOP.
 - c. At least once per quarter during continuing operations.
 - d. After absence from the job in excess of 15 consecutive workdays.

2. I have read or have had read to me and understand the general and specific safety and environmental requirements, personnel and explosive limits, work description and inspection requirements necessary to accomplish my operation. I have been thoroughly trained in, and am familiar with, my part of the operation, and I agree to abide by these instructions throughout my assignment to the operation.

NAME	DATE	OPERATION NUMBER
_____	_____	_____
_____	_____	_____
_____	_____	_____
_____	_____	_____
_____	_____	_____
_____	_____	_____
_____	_____	_____
_____	_____	_____
_____	_____	_____
_____	_____	_____
_____	_____	_____
_____	_____	_____
_____	_____	_____
_____	_____	_____
_____	_____	_____
_____	_____	_____
_____	_____	_____
_____	_____	_____
_____	_____	_____
_____	_____	_____
_____	_____	_____
_____	_____	_____
_____	_____	_____

SOP NO. AC-C256-M-014 DATE 11 JAN 1990

REV NO. _____ DATE _____

CHANGE NO. _____ DATE _____

INDEX OF OPERATIONS

<u>OPER NO.</u>	<u>BLDG NO. OR SITE</u>	<u>BAY NO.</u>	<u>TOTAL EXPL ALLOWED IN BAY (REF COL. 3)</u>	<u>DESCRIPTION OF OPERATION</u>	<u>PAGE NO.</u>
1	600 Area	N/A	Inert	Preparation of Test Site	9
2	628	I	.101	Receipt of Test Ammunition	15
3	628	G	.057	Operational Shield Test	17
4	628	I	.035	Disposition of Test Ammunition	27
5	628	G	.057	Misfire Procedures	29

REMARKS:

The purpose of this test is to certify that an operator occupying an individual working cell of the APE 2245 and a transient standing behind the operator are shielded from an incident occurring in an adjacent working cell.

Shield testing will be conducted on a single work cell consisting of two side shields and a top shield. Due to costs involved, no functional equipment will be used in the test but the physical size, construction and layout of various equipment will be duplicated to simulate their vulnerability to the explosive incident, this will include simulation of hydraulic lines and cylinders loaded with fluid, located on the inside of the machine.

Test ammunition will be constructed of an electric squib substituted for the percussion primer, 123 grains of M9 propellant loaded in an ignition cartridge to represent the effects of the M6 or M8 Ignition Cartridge, and a 25 percent overload of 31 grains of M9 propellant. The electric squib, ignition cartridge and 25 percent overload of propellant shall be inserted into an inert M170 fin assembly. Functioning shall be defined as deflagration of the propellant.

A Line Layout of this SOP is at Figure 1.

REFERENCES: DOD 51.00.76M
AMC-R 385-100
AMC-R 700-107
SVADA-R 742-3
Operational Shield Test Plan for Ammunition
Peculiar Equipment 2245 Motor Disassembly
Machine
APE 1963 Operational Manual
SV-0000-L-006
SV-0000-T-328
TM 9-1300-277

GENERAL SAFETY REQUIREMENTS

1. Standing Operating Procedure (SOP), applicable portion, shall be conspicuously posted in rooms or bays involved in the operation. Supervisory personnel shall maintain copies of a complete SOP and be responsible for the enforcement of its provisions.
2. There will be no deviation or change from the approved SOP without prior approval of the Center Director and the Installation Commander, or their designated representatives.
3. Employees will not tamper with any safety devices or protective equipment.
4. Any defect or unusual condition noted that is not covered by this SOP will be reported immediately to the test engineer or project engineer.
5. Appropriate fire symbol and chemical hazard marker shall be displayed in such a manner as to be easily visible from all roads of approach.
6. Care will be taken to limit exposure of a minimum number of personnel, for a minimum time, to a minimum amount of hazardous material consistent with safe and efficient operations.
7. Personnel and installed equipment will be so located that operators will have an unobstructed path of travel to the nearest available exits.
8. Work locations will be maintained and left in a neat and orderly condition. Good housekeeping must be maintained!
9. All handtools, ferrous and/or nonferrous, shall be maintained in a good state of repair.
10. Operators lifting material will use proper, safe hand holds, assume proper lifting position, avoid twisting when lifting or carrying, and avoid sharp objects.
11. Each Material Handling Equipment (MHE) and/or vehicle operator will have in his possession a valid operators permit for the particular piece of equipment to be operated.
12. Appropriate fire symbols and/or chemical hazard symbols shall be displayed on vehicles used in transporting ammunition/explosives. Fire symbols and/or chemical hazard symbols will be removed from the conveyance after last explosive item is removed.
13. Leather or leather-palmed gloves will be worn when handling wooden boxes.
14. Steel toed safety shoes will be worn by all personnel engaged in material handling operations.

15. Explosives, loaded ammunition, packaged ammunition, or bulk explosives shall not be handled roughly, thrown about, tumbled, dropped, or walked over other explosives or ammunition. Massive ammunition items, packaged in Department of Transportation (DOT) approved containers designed to permit dragging, rolling or towing, may be so moved when necessary during handling for storage and transportation.
16. Any ammunition determined to be dangerous to handle or store will be reported immediately to the test engineer. Operations will be suspended, and, if warranted, evacuated pending further instructions.
17. All installed metallic equipment shall be grounded and grounding system shall be tested for electrical resistance and continuity prior to start of operation in accordance with paragraph 7-4, AMC-R 385-100 and SV-0000-T-328.
18. The test engineer will be responsible for directing the actions to be taken during the event of an electrical storm. His decision will be based on the operation being performed and the severity of the electrical storm. If Building 628 is deemed to be hazardous, personnel will evacuate to Building 626. If the 600 area is deemed to be hazardous, personnel will evacuate to their normal work stations.
19. Matches, lighters, or other spark producing devices, are forbidden at test site, and in the ammunition area.
20. Before starting operation, all personnel involved in operation/test should be walked through complete operation using the approved SOP as a guide.
21. Surveillance activity will inspect all operations for safety and compliance with this SOP.
22. All equipment and tools must be inspected/decontaminated IAW Savanna Army Depot Activity Regulation (SVADA-R) 742-3 prior to the removal from an explosive area.
23. No jewelry or ornaments shall be worn on or near operations involving moving machinery.
24. The test engineer will brief employees on procedures for accidents and is responsible for reporting all injuries and accidents to their Safety Office.
25. All fires starting in the vicinity of ammunition or explosives shall be reported immediately to the Fire Department (911) and fought immediately with all available means and without awaiting specific instructions. However, if the fire involves explosive materials or is supplying heat to it, or if the fire is so large that it cannot be extinguished with the equipment at hand, the personnel involved shall evacuate and seek safety.
26. If possible, the test engineer or a designated person shall meet the Fire Department in order to brief them of the incident before firefighting forces are committed.
27. At least one individual trained to render first aid will be present during all explosive operations.

OPERATIONS FORMAT
(Normal Operation)

A. STANDING OPERATING PROCEDURE FOR:
Engineering Test of APE 2245

B. OPERATION NO.:
 _____1_____
 C. BAY NO.:
 _____600 Area_____
 D. SOP NO.: _____ DATE: _____
AC-C256-M-014 11 JAN 1989
 E. REV NO.: _____ DATE: _____
 F. CHANGE NO.: _____ DATE: _____

G. OPERATION:
Preparation of Test Site (600 Area)

H. EXPLOSIVE LIMITS:
 UNITS: None EXPLOSIVE LBS: Inert

I. PERSONNEL LIMITS:
 OPERATORS: 6 TRANSIENTS: 6

J. STEP NO. DESCRIPTION SPECIFIC INSTRUCTION
 (Safety, Operational, Quality Characteristics.)

1. Locate instrumentation van.
2. Locate trauma-aid kit.

1. (D) If used, position instrumentation van outside Building 628 IAW Figure 1, Line Layout.

2. (S) (D) Position a trauma-aid kit in Building 626.

NOTE

TELEPHONE FOR THIS TEST IS LOCATED IN BUILDING 626 (EXT 8664).

3. Test telephone.
4. Locate fire extinguishers.

3. (D) Test telephone by dialing extension 8929 (SMCAC-DEV). Request person answering to dial extension 8664 to check that the telephone rings.

4. (S) (D) Position one (1) each, fire extinguisher as follows:

- a. Building 626.
- b. Outside Bay I.
- c. Outside Bay G.

OPERATIONS FORMAT CONTINUATION SHEET
(Normal Operation)

STEP NO.	DESCRIPTION	SPECIFIC INSTRUCTION (Safety, Operational, Quality Characteristics.)
5.	Locate APE 2245.	5. (O) The simulated cell of the APE-2245 will be setup in Bay G of Building 628 IAW Figure 2, Simulated APE 2245 Setup and Figure 1, Line Layout.
6.	Locate grounding mat/plate.	6. a. (O) Position one grounding mat/plate in the simulated cell of the APE 2245. b. (S) (O) Electrically bond mat/plate to Building 628 grounding system.
7.	Locate test instrumentation.	7. a. (O) Position pressure transducers and heat flux instrumentation in Bay G of Building 628 IAW Figure 3, Test Instrumentation Setup and Figure 1, Line Layout. b. (O) Position a high speed motion picture camera IAW Figure 1, Line Layout. c. (S) (O) Camera should be barricaded to protect camera. d. (O) Position a closed-circuit television system IAW Figure 1, Line Layout. e. (O) Position recording instrumentation in Bay F of Building 628 IAW Figure 1, Line Layout. f. (O) Ground recording instruments.

OPERATIONS FORMAT CONTINUATION SHEET
(Normal Operation)

STEP NO.	DESCRIPTION	SPECIFIC INSTRUCTION (Safety, Operational, Quality Characteristics.)
7.	Locate test instrumentation (continued).	<p>7. g. (O) Position APE 1963 electronic unit in Building 626 IAW Figure 1, Line Layout.</p> <p>h. (O) Ground APE 1963.</p>
8.	Locate cabling.	<p>8. a. (O) Route and connect cabling between test instrumentation in Bay F to recording instrumentation in Bay G.</p> <p>b. (O) Route firing wires from Bay F to Building 626.</p> <p>c. (S) (O) Shunt firing wires until ready for testing.</p>
9.	Locate inert projectile body.	<p>9. a. (O) Position inert projectile body in fixture of the APE 2245 IAW Figure 4, Mortar Holding Fixture.</p> <p>b. (O) Close lower clamp and tighten knurled knob to secure inert projectile body.</p>
10.	Locate the M149 fin assemblies.	10. (O) Position two (2) each, inert M149 fin assemblies in Bay G.
11.	Locate the APE 1953.	11. (O) Position the APE 1953 at the electrical outlet between Bays D and E, Building 628.
12.	Inspect and test grounds.	12. (S) (O) Surveillance personnel using procedures in paragraphs 7-2 and 7-4 of AMC-R 385-100 and SOP No. SV-0000-T-328, will inspect and test all grounds.

OPERATIONS FORMAT CONTINUATION SHEET
(Normal Operation)

STEP NO.	DESCRIPTION	SPECIFIC INSTRUCTION (Safety, Operational, Quality Characteristics.)
13.	Locate barricades and signs.	13. a. (S) (O) Position barricades and controlled test signs at west and east entrance gates of the test-site area. b. (S) (O) Inspect to ensure that all other test-site area gates are locked. c. (S) (O) Position controlled test signs on railroad gates and back gate. d. (S) (O) Position one (1) each, radio transmission prohibited signs 200 feet from Building 628 at the following locations: (1) Along north service road. (2) Along center service road. (3) Along south service road.
14.	Locate warning flag.	14. (O) Attach red warning flag to rope on flagpole located on north side of Building 628.

K. SPECIAL REQUIREMENTS.

Operators will wear safety shoes when preparing test-site.

L. EQUIPMENT, TOOLS, GAUGES, AND SUPPLIES.

<u>ITEM</u>	<u>QTY REQD</u>	<u>SPEC NO. OR DWG NO.</u>	<u>MCSN OR NSN NO.</u>
1. Shoes, Safety	1 pair per Operator	MIL-S-418	
2. Instrumentation Van	1 each		Locally Procured
3. Trauma-aid Kit	1 each	SVADA Approved	Locally Procured
4. Fire Extinguisher (10-pound, 1A10BC, Dry Chemical Rated)	3 each		Locally Procured
5. APE 2245, Simulated	1 each		Locally Fabricated
6. Pressure Transducers	4 each		Locally Procured
7. Heat Flux Instrumentation	4 each		Locally Procured
8. High-Speed Movie Camera	1 each	Model 42-0002	
9. APE 1072M2 Closed- Circuit Television System	1 each		APE 1072M2
10. Recording Instrumentation	As required		Locally Procured
11. Auxiliary Lighting	As required		Locally Procured
12. APE 1963 Electronic Control Unit	1 each		APE 1963
13. Firing Wire	200 feet	16AWG	
14. Inert Projectile Body	1 each		Locally Procured
15. Inert M149 Fin Assembly	2 each		Locally Procured
16. Road Barricade	2 each		Locally Procured
17. Controlled Test Sign	5 each		Locally Procured
18. Radio Transmission Prohibited Sign	3 each		Locally Procured
19. Red Warning Flag	1 each		Locally Fabricated

L. EQUIPMENT, TOOLS, GAUGES, AND SUPPLIES (continued).

<u>ITEM</u>	<u>QTY REQD</u>	<u>SPEC NO. OR DWG NO.</u>	<u>MCSN OR NSN NO.</u>
20. Grounding Mat/Plate	1 each		Locally Procured
21. APE 1953	1 each		APE 1953

OPERATIONS FORMAT
(Normal Operation)

<p>A. <u>STANDING OPERATING PROCEDURE FOR:</u> <u>Engineering Test of APE 2245</u></p> <p>_____</p> <p>_____</p> <p>_____</p>	<p>B. <u>OPERATION NO.:</u> <u>2</u></p> <p>C. <u>BAY NO.:</u> <u>Bay 1, Building 628</u></p> <p>D. <u>SOP NO.:</u> <u>AC-C256-N-014</u> <u>DATE:</u> <u>11 JAN 1990</u></p> <p>E. <u>REV NO.:</u> <u>DATE:</u></p> <p>F. <u>CHANGE NO.:</u> <u>DATE:</u></p>
--	--

G. OPERATION:

Receipt of Test Ammunition

H. EXPLOSIVE LIMITS:
UNITS: 3 Loaded Fin Assemblies, 2 M6 Ignition Ctgs. EXPLOSIVE LBS: .066 and .035, respectively

I. PERSONNEL LIMITS:
OPERATORS: 6 TRANSIENTS: 6

<u>J. STEP</u>	<u>DESCRIPTION</u>	<u>SPECIFIC INSTRUCTION</u>
<u>NO.</u>		<u>(Safety, Operational, Quality Characteristics.)</u>

- | | |
|---|--|
| <p>1. Receive test ammunition.</p> <p>2. Unload motor vehicle.</p> <p>3. Inventory test ammunition.</p> | <p>1. a. (O) Ammunition will be transported IAW SOP SV-0000-L-006, On Depot Movement.</p> <p style="padding-left: 40px;">b. Position Fire Symbol 4 on Building 628.</p> <p>2. (O) Manually remove test ammunition from carrier and place in temporary storage in Bay I.</p> <p>3. a. (O) Inventory test ammunition to ensure that correct quantity is delivered. Quantity and lot number will be verified against DA Form 4508.</p> <p style="padding-left: 40px;">b. (O) Release carrier after completion of operation.</p> |
|---|--|

K. SPECIAL REQUIREMENTS.

When building is not occupied, temporary storage bay must be locked with an approved locking device if explosives are present. Ammunition or explosives will not remain in storage bay overnight unless bay meets all requirements of DOD 5100.76M (Physical Security of Weapons, Ammunition, and Explosives). If bay meets the requirements of DOD 5100.76M and ammunition is to remain in bay overnight, USADACS test engineer will notify the chiefs of Security Branch and Fire Prevention and Protection Branch as to the type of ammunition stored there, fire symbol, building number, and requirement for checks of locks IAW DOD 5100.76M.

L. EQUIPMENT, TOOLS, GAUGES, AND SUPPLIES.

<u>ITEM</u>	<u>QTY REQD</u>	<u>SPEC NO. OR DWG NO.</u>	<u>MCSN OR NSN NO.</u>
1. Shoes, Safety	1 pair per individual	MIL-S-418	
2. High Security Padlock	1 each		5340-00-799-8248
3. Fire Symbol	As required	No. 4	Locally Fabricated

OPERATIONS FORMAT
(Normal Operation)

A. **STANDING OPERATING PROCEDURE FOR:**
Engineering Test of APE 2245

B. **OPERATION NO.:**
 _____3_____

C. **BAY NO.:**
 _____Bay G, Building 628_____

D. **SOP NO.:** _____AC-C256-M-014_____ **DATE:** _____11 JAN 1990_____

E. **REV NO.:** _____ _____ **DATE:** _____ _____

F. **CHANGE NO.:** _____ _____ **DATE:** _____ _____

G. **OPERATION:**

Operational Shield Test

H. **EXPLOSIVE LIMITS:**

UNITS: 1 Loaded Fin Assy., 2 M6 Ignition Ctgs.

EXPLOSIVE LBS: .022 and .035, respectively

I. **PERSONNEL LIMITS:**

OPERATORS: 6

TRANSIENTS: 6

J. **STEP NO.**

DESCRIPTION

SPECIFIC INSTRUCTION
(Safety, Operational, Quality Characteristics.)

1. Raise warning flag.

1. (S) (O) Raise warning flag on flagpole located on north side of Building 628.

2. Make pretest notifications.

2. (S) (O) Notify the following that a test is being conducted at Building 628:

(1) USADACS Safety Manager (ext 8976)

(2) Chief of Quality Assurance (ext 8624)

(3) Fire Department (ext 8431)

(4) Facilities Engineer (ext 8521)

(5) Security Office (ext 8881)

3. Test conductive shoes.

3. a. (S) (O) Using APE 1953, test conductive shoes of all individuals performing this operation IAW AMC-R385-100, para 10-13.

OPERATIONS FORMAT CONTINUATION SHEET
(Normal Operation)

STEP NO.	DESCRIPTION	SPECIFIC INSTRUCTION (Safety, Operational, Quality Characteristics.)
3.	Test conductive shoes (continued).	3. b. (O) Documentation of this test will be kept by the Test Engineer.
4.	Test firing wires.	4. a. (O) Check galvanometer by holding a piece of metal across the terminals. (1) (O) Wide deflection indicates a good meter. (2) (O) If not, replace galvanometer. b. (O) Shunt firing wires at Building 626. c. (O) Untwist the wires at Bay F and touch the ends to galvanometer posts. (1) (O) No reading indicates a break in the wire. Repair and retest. (2) (O) A slight movement of the needle indicates high resistance, replace wires. (3) (O) A wide deflection indicates good firing leads. d. (O) Untwist the firing wire leads at Building 626. (1) (O) No reading indicates a good firing wire. (2) (O) Any reading indicates a short in the wire. Repair or replace wire and retest. e. (S) (O) Shunt firing wire leads at Bay F, Building 628 and at Building 626.

OPERATIONS FORMAT CONTINUATION SHEET
(Normal Operation)

STEP NO.	DESCRIPTION	SPECIFIC INSTRUCTION (Safety, Operational, Quality Characteristics.)
5.	Activate monitor equipment.	5. (O) Turn on closed-circuit television and ensure that the operations being performed in Bay G will be available in Building 626.
6.	Clear Building 628 of excess personnel.	6. a. (O) All personnel, except for the following, will retire to Building 626: (1) Explosive operator. (2) Project engineer. (3) Test engineer. (4) Surveillance and/or safety representative. b. (S) (O) Check area to assure that all excess personnel are in Building 626 and no unauthorized personnel are in or near test area.
7.	Position adjacent ignition cartridges.	7. a. (O) Obtain two (2) M6 ignition cartridges from Bay I and manually transport to Bay G. b. (O) Insert one (1) M6 ignition cartridge into each of the M149 fin assemblies. c. (O) Position the M149 fin assemblies on specially constructed stands IAW Figure 5, Adjacent Ignition Cartridge Setup. d. (O) Attach M149 fin assemblies to stands by threading assembly onto stud on stand.

OPERATIONS FORMAT CONTINUATION SHEET
(Normal Operation)

STEP NO.	DESCRIPTION	SPECIFIC INSTRUCTION (Safety, Operational, Quality Characteristics.)
8. Position propellant loaded fin assembly.	<p>8. a. (O) Obtain one (1) propellant loaded M170 fin assembly from Bay I.</p> <p>b. (O) Attach propellant loaded fin assembly to inert projectile body by threading fin assembly onto projectile body.</p> <p>c. (O) Close upper clamp around fin assembly and close toggle clamp.</p> <p>d. (O) After test ammunition has been properly positioned, all personnel will retire to Bay F.</p>	
9. Connect wires.	<p>9. a. (O) Check serviceability of No. 47 radio pilot lamp by connecting leads to a dry cell (lamp should glow).</p> <p>b. (O) At Bay F, untwist ends of firing wire.</p> <p>c. (O) Place leads of No. 47 radio pilot lamp across leads of firing wire (lamp should not glow). If lamp glows, further testing will not be accomplished.</p> <p>d. (O) Connect firing wires to leads on fin assembly in Bay G.</p>	
10. Inspect test setup.	10. (O) Project engineer and test engineer will inspect test setup.	

OPERATIONS FORMAT CONTINUATION SHEET
(Normal Operation)

STEP NO.	DESCRIPTION	SPECIFIC INSTRUCTION (Safety, Operational, Quality Characteristics.)
11. Clear Building 628 of personnel.	11. a. (S) (O) Explosive operator and USADACS representatives shall check area to assure that all personnel are in Building 626, and no unauthorized personnel are in or near test area. b. (S) (O) Sound the siren located in Bay A for 10 seconds. c. (O) All personnel will retire to Building 626.	
12. Test continuity of system and attach firing wires to electronic control unit.	12. a. (S) (O) Ensure APE 1963 main power switch is in the "off" position. b. (O) At Building 626, untwist ends of firing wire and touch ends to galvanometer posts. This should cause a wide deflection of the needle (which indicates continuity). c. (O) If system has continuity, connect firing wires to APE 1963. d. (S) (O) If there is no continuity, twist ends of test wires together, check out system, and retest continuity.	
13. Activate test instrumentation.	13. (O) Remotely turn on high-speed camera and recording instrumentation.	
14. Initiate fin assembly.	14. a. (S) (O) Explosive operator shall ensure that all test personnel are inside building and the test area is clear, before unlocking switch.	

OPERATIONS FORMAT CONTINUATION SHEET
(Normal Operation)

STEP NO.	DESCRIPTION	SPECIFIC INSTRUCTION (Safety, Operational, Quality Characteristics.)
14.	Initiate fin assembly (continued).	<p>14. b. (O) Insert key in switch and turn to "on" position. Operate APE 1963 IAW instructions in APE operational manual to function loaded fin assembly.</p> <p>c. (S) (O) Lock APE 1963 in "off" position and remove key.</p> <p>d. (S) (O) Disconnect firing wires from APE 1963 and twist them together.</p>
15.	Deactivate test instrumentation.	15. (O) Remotely turn off high-speed camera and recording instrumentation.
16.	Misfire Procedures.	16. (S) (O) If required, misfires will be handled IAW Operation No. 5, Misfire Procedures.
17.	Return to Building 628.	<p>17. a. (S) (O) Test engineer and surveillance representative will return to Bay 6 at Building 628 and inspect for any hazards.</p> <p>b. (O) Upon notification, other personnel may return to Building 628.</p>
18.	Remove and package expended fin assembly.	<p>18. a. (O) Remove firing wire leads from wires on expended M170 fin assembly.</p> <p>b. (O) Shunt firing wire leads.</p> <p>c. (O) Open toggle clamp and open upper clamp.</p>

OPERATIONS FORMAT CONTINUATION SHEET
(Normal Operation)

STEP NO.	DESCRIPTION	SPECIFIC INSTRUCTION (Safety, Operational, Quality Characteristics.)
18. Remove and package expended fin assembly (continued).	18. d. (O) Remove M170 fin assembly from projectile body by turning fin assembly in a counterclockwise (CCW) direction by hand. If this cannot be accomplished, use APE 2128 and breaker bar from wrench set. e. (O) Place expended M170 fin assembly in M2A1 container.	
19. Inspect APE 2245.	19. a. (O) Inspect APE 2245 for physical damage. b. (O) If no damage is observed, repeat the test for an additional fin assembly.	
<u>NOTE</u> SECOND TEST WILL BE STARTED WITH ADJACENT IGNITION CARTRIDGES IN POSITION.		
20. Repeat test.	20. (O) Perform steps 3 - 6 and 8 - 19b.	
21. Remove adjacent ignition cartridges.	21. a. (O) Remove two adjacent ignition cartridges with fin assemblies from stand by turning fin assemblies in a counterclockwise (CCW) direction by hand. If this cannot be accomplished, use APE 2128 and breaker bar from wrench set. b. (O) Remove one (1) M6 ignition cartridge from each of the two (2) M149 fin assemblies. c. (O) Place the two (2) M6 ignition cartridges in original shipping container in Bay I.	

OPERATIONS FORMAT CONTINUATION SHEET
(Normal Operation)

STEP NO.	DESCRIPTION	SPECIFIC INSTRUCTION (Safety, Operational, Quality Characteristics.)
21.	Remove adjacent ignition cartridges (continued).	21. d. (O) Retain the two (2) M149 fin assemblies.
		<u>NOTE</u> PRIOR TO THE NEXT TEST, POSITIONING OF ITEMS ILLUSTRATED IN FIGURES 2, 3, AND 5 WILL BE TURNED 90 DEGREES IN A CLOCKWISE (CW) DIRECTION FOR SETUP.
22.	Locate APE 2245.	22. (O) Rotate the simulated cell of the APE 2245 90 degrees in a clockwise (CW) direction.
23.	Locate test instrumentation.	23. (O) Rotate pressure transducers and heat flux instrumentation 90 degrees in a clockwise (CW) direction.
24.	Repeat test.	24. (O) Perform steps 3 - 19a and 21.
25.	Package inert mortar components.	25. a. (O) Place the two (2) M149 fin assemblies (retained in paragraph 20.d) into M548 container. b. (O) Loosen knurled knob on lower clamp of simulated APE 2245. c. (O) Open lower clamp and remove inert projectile body. d. (O) Place inert projectile body in M548 container.

K. SPECIAL REQUIREMENTS:

Test Engineer will obtain and retain the key to the APE 1963 when it is not required for use by the explosive operator.

L. EQUIPMENT, TOOLS, GAUGES, AND SUPPLIES.

<u>ITEM</u>	<u>QTY REQD</u>	<u>SPEC NO. OR DWG NO.</u>	<u>MCSN OR NSN NO.</u>
1. Conductive Safety Shoes	1 pair per Operator	MIL-S-3794	
2. Flame-Resistant Coveralls	1 pair per Operator	MIL-C-14610	
3. APE 2245, Simulated	1 each		Locally Fabricated
4. Pressure Transducers	4 each		Locally Procured
5. Heat Flux Instrumentation	4 each		Locally Procured
6. High-Speed Movie Camera	1 each	Model 42-0002	
7. APE 1072M2 Closed-Circuit Television System	1 each		APE 1072M2
8. Recording Instrumentation	As required		Locally Procured
9. Auxiliary Lighting	As required		Locally Procured
10. APE 1963 Electronic Control Unit	1 each		APE 1963
11. Firing Wire	200 feet	16AWG	
12. Red Warning Flag	1 each		Locally Fabricated
13. Galvanometer	1 each		6625-00-539-8444
14. No. 47 Radio Pilot Lamp	1 each		6240-00-155-8706
15. 1 1/2-volt Battery (C or D)	1 each		6135-00-935-5301 or 6135-00-930-0030
16. Inert Projectile Body	1 each		Locally Procured
17. Inert M149 Fin Assembly	2 each		Locally Procured
18. M548 Container	1 each		Locally Procured

L. EQUIPMENT, TOOLS, GAUGES, AND SUPPLIES (continued).

<u>ITEM</u>	<u>QTY REQD</u>	<u>SPEC NO. OR DWG NO.</u>	<u>MCSN OR NSN NO.</u>
19. APE 2128 Fin Removal Tool	1 each		APE 2128
20. Wrench Set, 1/2-In Sq Drive	1 each		5120-00-081-2301
21. M2A1 Container	1 each		Locally Procured
22. APE 1953	1 each		APE 1953
23. Grounding Mat/Plate	1 each		Locally Procured

A. STANDING OPERATING PROCEDURE FOR:
Engineering Test of APE 2245

B. OPERATION NO.:
 _____ 4 _____

C. BAY NO.:
 _____ Bay I, Building 628 _____

D. SOP NO.: _____ DATE: _____
 AC-C256-M-014 11 JAN 1990

E. REV NO.: _____ DATE: _____

F. CHANGE NO.: _____ DATE: _____

G. OPERATION:

Disposition of Test Ammunition

H. EXPLOSIVE LIMITS:
 UNITS: Two (2) M6 Ignition Ctgs. EXPLOSIVE LBS: .035

I. PERSONNEL LIMITS:
 OPERATORS: 6 TRANSIENTS: 6

J. STEP NO. DESCRIPTION SPECIFIC INSTRUCTION
 (Safety, Operational, Quality Characteristics.)

1. Disposition of inert mortar components.

1. (O) Inert mortar components placed in M548 container will be retained for future tests.

2. Disposition of M6 ignition ctgs.

2. (O) M6 ignition ctgs. packaged in original shipping container will be transferred to storage IAW SOP SV-0000-L-006.

3. Disposition of expended fin assemblies.

3. (O) Expended fin assemblies placed in M2A1 container will be stored in Bay E, Building 628. These items will be decontaminated to the XXX level IAW SVADA-R 742-3, Explosive Decontamination, prior to removal from the 600 Area.

4. Remove warning flag.

4. (O) Lower and remove red warning flag from flagpole.

OPERATIONS FORMAT CONTINUATION SHEET
(Normal Operation)

STEP NO.	DESCRIPTION	SPECIFIC INSTRUCTION (Safety, Operational, Quality Characteristics.)
5.	Make posttest notifications.	5. (S) (O) Notify the following when testing has been completed: (1) USADACS Safety Manager (ext 8976) (2) Chief of Quality Assurance (ext 8624) (3) Fire Department (ext 8431) (4) Facilities Engineer (ext 8521) (5) Security Office (ext 8881)
6.	Clean and secure test area.	6. (O) Perform closure operations as directed by test engineer.
K.	SPECIAL REQUIREMENTS: None.	
L.	EQUIPMENT, TOOLS, GAUGES, AND SUPPLIES: None.	

OPERATIONS FORMAT
(Normal Operation)

A. STANDING OPERATING PROCEDURE FOR:
Engineering Test of APE 2245

B. OPERATION NO.:
5

C. BAY NO.:
Building 626; Bay G, Building 629

D. SDP NO.: AC-C256-M-014 DATE: 11 JAN 1990

E. REV NO.: DATE:

F. CHANGE NO.: DATE:

G. OPERATION:

Misfire Procedures

H. EXPLOSIVE LIMITS:
UNITS: 1 Loaded Fin Assy., 2 M6 Ignition Ctgs. EXPLOSIVE LBS: .022 and .035, respectively

I. PERSONNEL LIMITS:
OPERATORS: 6 TRANSIENTS: 6

J. STEP DESCRIPTION SPECIFIC INSTRUCTION
NO. (Safety, Operational, Quality Characteristics.)

1. Handling electric misfires.

1. a. (O) Check firing wire connections to APE 1963 to ensure that they will provide good contact.
- b. (O) Connect firing wires to the APE 1963.
- c. (O) Remotely turn on high-speed camera and recording instrumentation.
- d. (O) Insert key in switch and turn to "on" position. Operate the APE 1963 IAW instructions in APE operational manual to function loaded fin assembly.
- e. (O) If required, make two or three more attempts to fire the circuit.
- f. (S) (O) Lock APE 1963 in the "off" position and remove the key.

OPERATIONS FORMAT CONTINUATION SHEET
(Normal Operation)

STEP NO.	DESCRIPTION	SPECIFIC INSTRUCTION (Safety, Operational, Quality Characteristics.)
1.	Handling electric misfires (continued).	<p>1. q. (O) Hold machine in upright position (terminals up) in either hand so that the plunger end of handle rests under base of thumb and fingers grasp machine body.</p> <p>r. (O) Squeeze hand sharply several times in succession until the charge fires. Not more than four strokes should be required.</p> <p>s. (O) Remotely turn off the high-speed camera and recording instrumentation.</p> <p>t. (O) If the assembly fires, disconnect firing wires from blasting machine and twist them together. Proceed IAW Operation No. 3, step 17.</p> <p>u. (O) If the blasting machine does not fire the circuit, proceed to subparagraph y.</p> <p>v. (S) (O) Wait at least 30 minutes after last attempt to ignite loaded fin assembly.</p> <p>w. (S) (O) The Test Engineer and the explosive operator will investigate the malfunction.</p> <p>x. (O) Visually inspect the firing wire from Building 626 to Bay G, Building 628.</p> <p>y. (O) Test conductive shoes IAW Operation No. 3, step no. 3.</p>

OPERATIONS FORMAT CONTINUATION SHEET
(Normal Operation)

STEP NO.	DESCRIPTION	SPECIFIC INSTRUCTION (Safety, Operational, Quality Characteristics.)
1.	Handling electric misfires (continued).	<p>1. q. (O) Hold machine in upright position (terminals up) in either hand so that the plunger end of handle rests under base of thumb and fingers grasp machine body.</p> <p>r. (O) Squeeze hand sharply several times in succession until the charge fires. Not more than four strokes should be required.</p> <p>s. (O) Remotely turn off the high-speed camera and recording instrumentation.</p> <p>t. (O) If the assembly fires, disconnect firing wires from blasting machine and twist them together. Proceed IAW Operation No. 3, step 17.</p> <p>u. (O) If the blasting machine does not fire the circuit, proceed to subparagraph v.</p> <p>v. (S) (O) Wait at least 30 minutes after last attempt to ignite loaded fin assembly.</p> <p>w. (S) (O) The Test Engineer and the explosive operator will investigate the malfunction.</p> <p>x. (O) Visually inspect the firing wire from Building 626 to Bay G, Building 628.</p> <p>y. (O) Test conductive shoes IAW Operation No. 3, step no. 3.</p>

OPERATIONS FORMAT CONTINUATION SHEET
(Normal Operation)

STEP NO.	DESCRIPTION	SPECIFIC INSTRUCTION (Safety, Operational, Quality Characteristics.)
1.	Handling electric misfires (continued).	<p>1. z. (O) Disconnect firing wires from leads on fin assembly.</p> <p>aa. (O) Shunt leads on fin assembly and firing wires.</p> <p>ab. (O) Test firing wires IAW Operation No. 3, step no. 3.</p> <p>ac. (O) Connect firing wires IAW Operation No. 3, step no. 8.</p> <p>ad. (O) All personnel will retire to Building 626.</p> <p>ae. (O) Using procedures in Operation No. 5, steps nos. 1i - 1s, attempt to fire the circuit.</p>
2.	Remove and package misfired fin assembly.	<p>2. a. (S) (O) Wait at least 30 minutes after last attempt to ignite loaded fin assembly.</p> <p>b. (S) (O) The Test Engineer and explosive operator will investigate the malfunction.</p> <p>c. (O) Test conductive shoes IAW Operation No. 3, step no. 3.</p> <p>d. (O) Remove firing wire leads from wires on misfired fin assembly.</p> <p>e. (S) (O) Shunt firing wire leads and fin assembly leads.</p> <p>f. (O) Open toggle clamp and open upper clamp.</p>

OPERATIONS FORMAT CONTINUATION SHEET
(Normal Operation)

STEP NO.	DESCRIPTION	SPECIFIC INSTRUCTION (Safety, Operational, Quality Characteristics.)
2.	Remove and package misfired fin assembly (continued).	g. (O) Remove the misfired fin assembly from projectile body by turning fin assembly in a counterclockwise (CCW) direction by hand. If this cannot be accomplished, use APE 2128 and breaker bar from wrench set. h. (O) Place misfired fin assembly into its original shipping container and transfer to Bay I pending disposition instructions. i. (O) All misfires will be returned to SDSLE-VMS for disposition.

K. SPECIAL REQUIREMENTS.

1. No more than two individuals will be permitted to leave the safety of Building 626 to investigate a misfire in Building 628.
2. Blasting machine, to be used during misfire procedures, will be stored in a locked ammunition box. Key to this box will be in the possession of the Test Engineer.

L. EQUIPMENT, TOOLS, GAUGES, AND SUPPLIES.

<u>ITEM</u>	<u>QTY REQD</u>	<u>SPEC NO. OR DWG NO.</u>	<u>MCSN OR NSN NO.</u>
1. Machine, Blasting, 10 Cap or Machine Blasting, 10 Cap, M32 or Machine Blasting, 50 Cap, M34	1 each		1375-00-212-4614
	1 each		1375-00-935-9173
	1 each		1375-00-567-0223
2. Galvanometer	1 each		6625-00-539-8444
3. No. 47 Radio Pilot Lamp	1 each		6240-00-155-8706
4. 1 1/2-Volt Battery (C or D)	1 each		6135-00-935-5301 or 6135-00-930-0030
5. APE 2128 Fin Removal Tool	1 each		APE 2128
6. Wrench Set, 1/2 -Inch Drive	1 each		5120-00-081-2301

BUILDING 626

BUILDING 626 WAS DESIGNED AS A BARRICADE FOR THE BUILDING VACUUM SYSTEM. THE ROOF, THE SOUTH WALL, THE CENTER WALL, AND BOTH END WALLS ARE REINFORCED CONCRETE. THE FRONT PORTION OF THIS BUILDING IS CONSTRUCTED WITH STEEL FRAMING AND COVERED WITH CORR ASBESTOS.

BUILDING 626

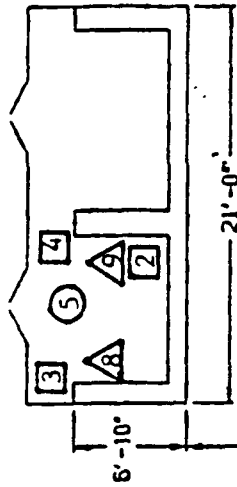

BUILDING 628

THE INTERIOR WALLS ARE 12 INCH REINFORCED CONCRETE. THE OUTER WALLS ARE HOLLOW TILE. THE ROOF IS 7/16 INCH CORR ASBESTOS. THE CORR ASBESTOS ROOF OVER BAY G HAS BEEN REPLACED WITH FIBERGLASS PANELS. THE RAMP LOCATED ON NORTH AND SOUTH SIDES OF BUILDING ARE ENCLOSED WITH CONCRETE BLOCKS.

TEST EQUIPMENT

- △ Instrumentation Van
- △ Simulated APE 2245
- △ Side-On Pressure Transducers
- △ Heat Flux Instruments
- △ High Speed Camera
- △ Television Camera
- △ Recording Instrumentation
- △ Television Monitor
- △ APE 1963

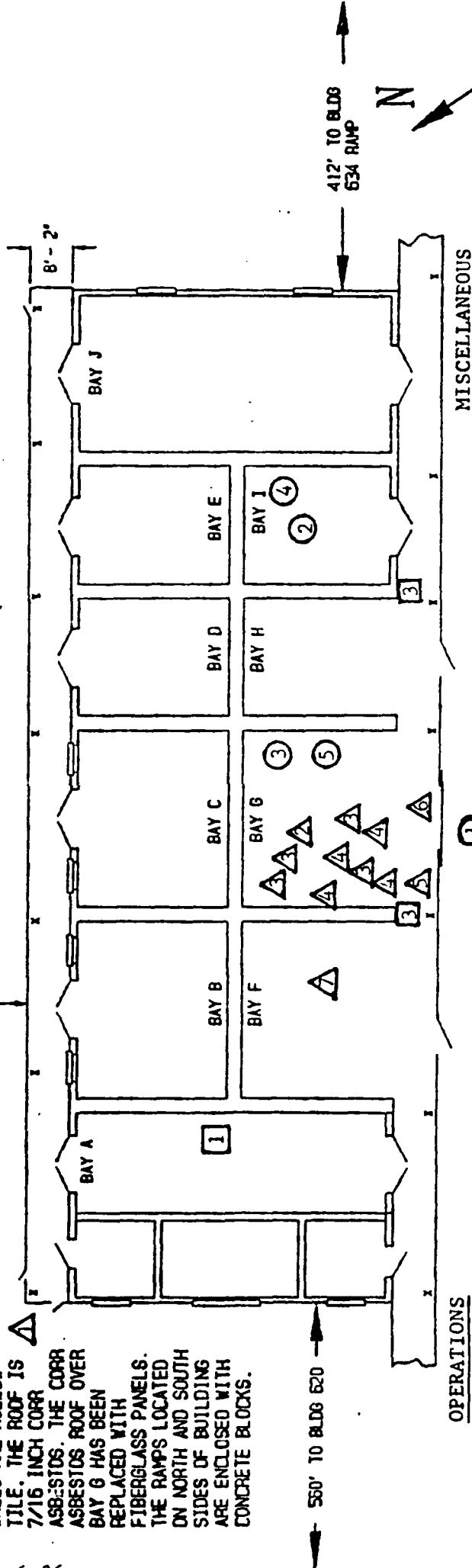

OPERATIONS

- ① Preparation of Test Site
- ② Receipt of Test Ammunition
- ③ Operational Shield Test
- ④ Disposition of Test Ammunition
- ⑤ Misfire Procedures

MISCELLANEOUS

- ① Siren
- ② Telephone
- ③ Fire Extinguisher
- ④ Trauma-Aid Kit

FIGURE 1 - THE FACILITY

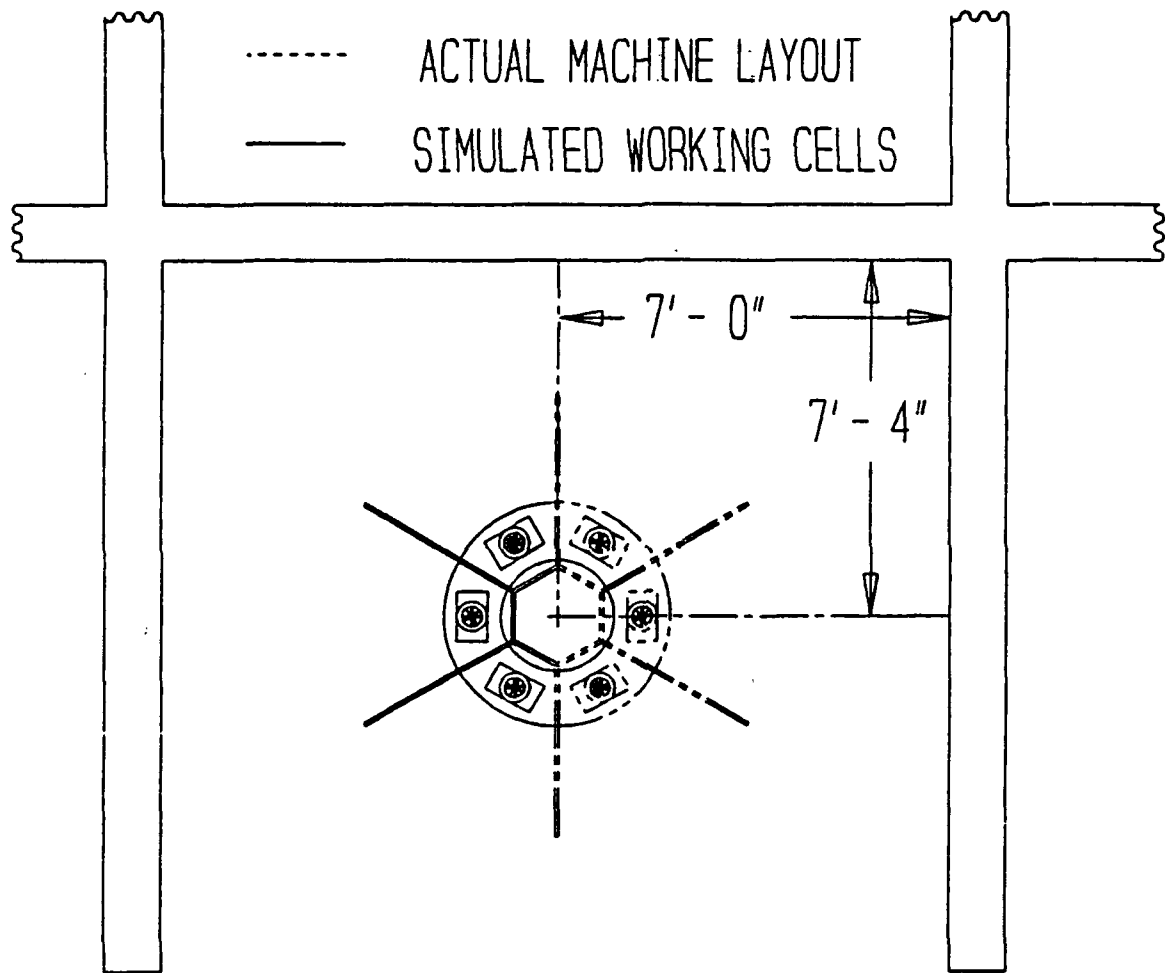

Figure 2
SIMULATED APE 2245 SET UP

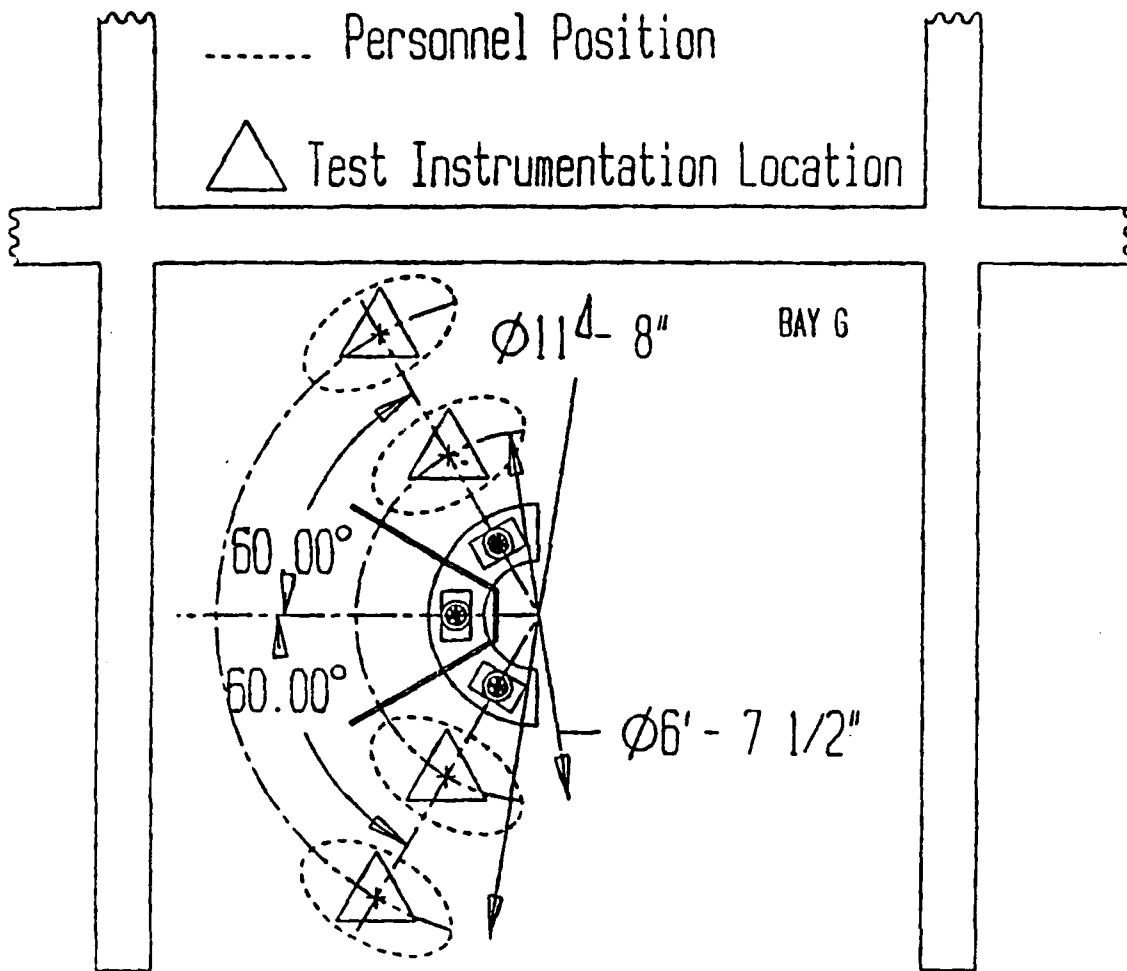

FIGURE 3
TEST INSTRUMENTATION SET UP

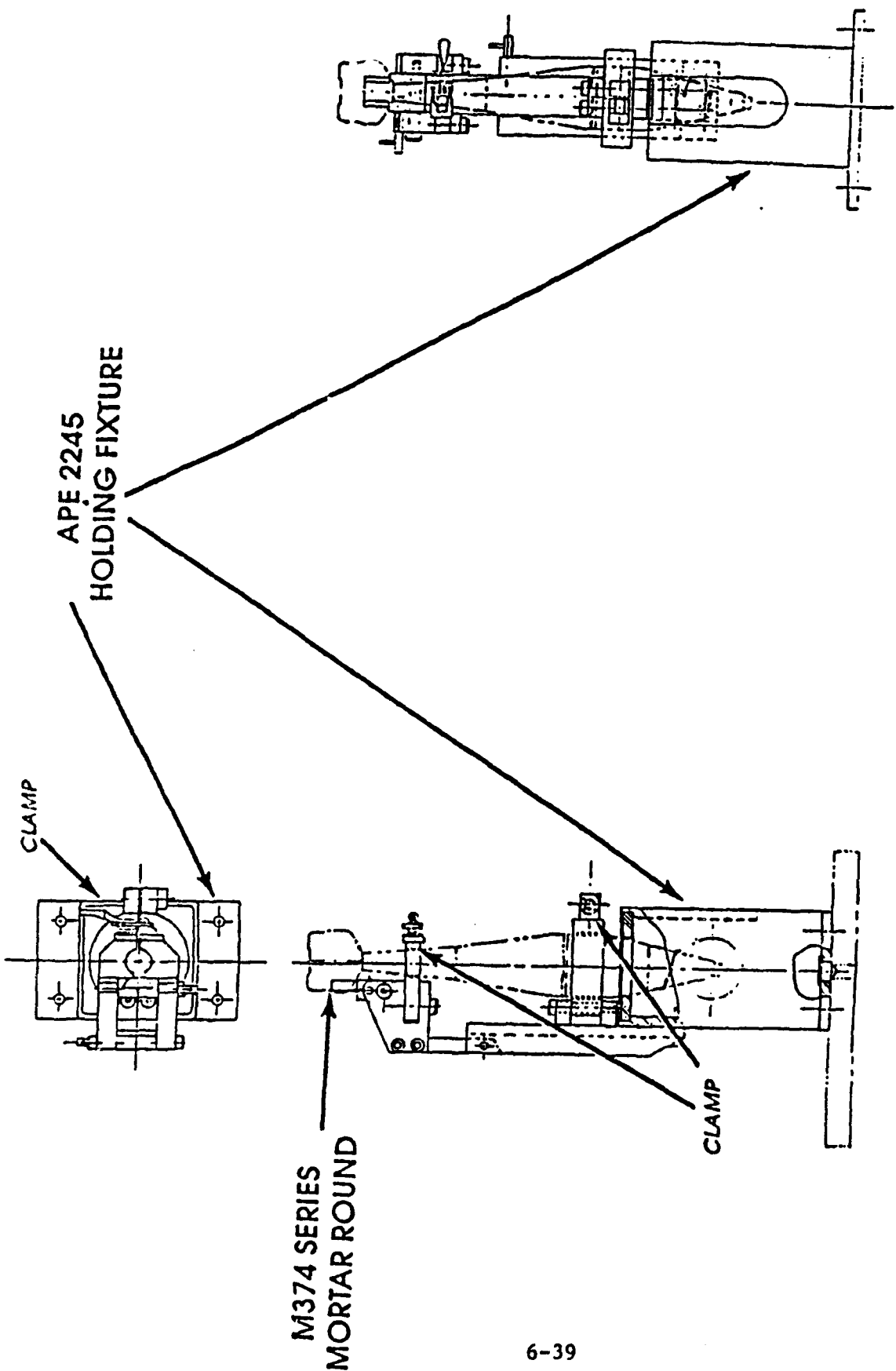

FIGURE 4
MORTAR HOLDING FIXTURE

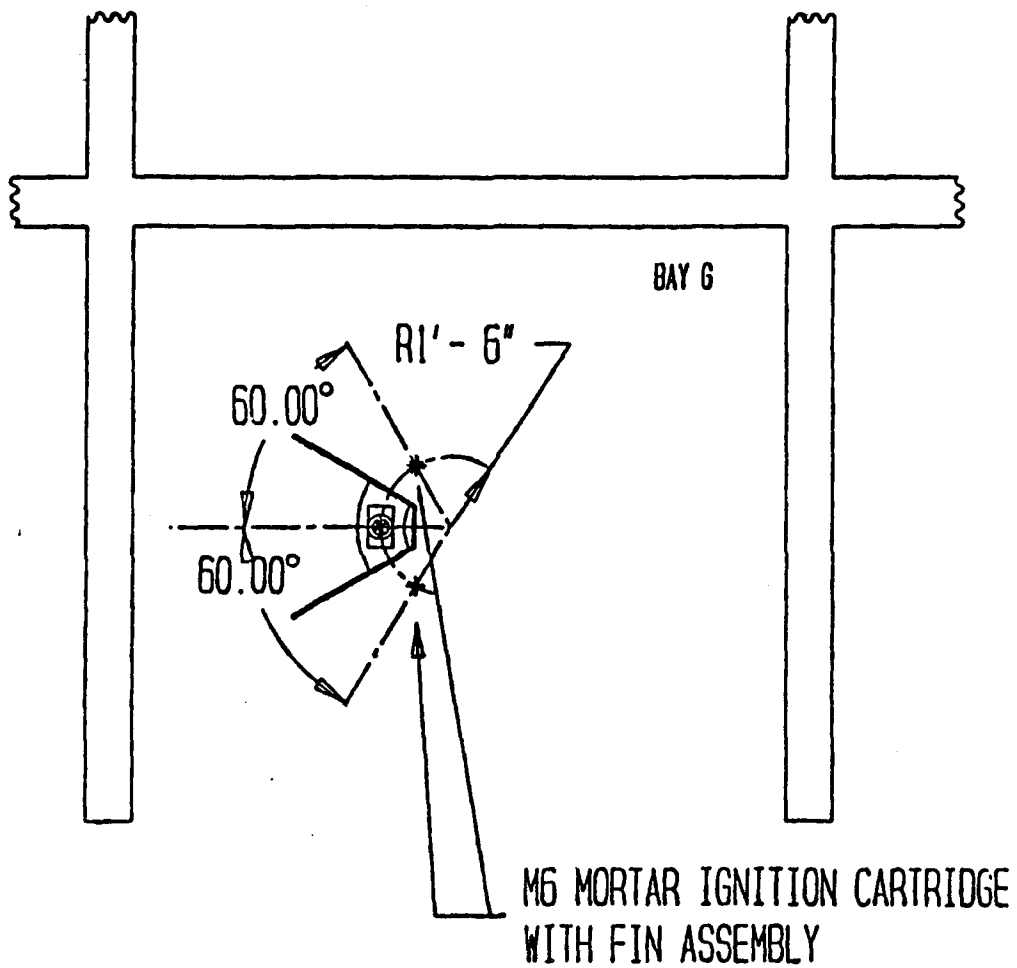

FIGURE 5
ADJACENT IGNITION CARTRIDGE SETUP

PART 7

PHOTOGRAPHS

Video coverage of this test is available on #3619-02, magnetic tape.

Explosive Test - Ape 2245 Mortar Ignition Cartridge Fixture, 12 January 1990.

Color, Audio - none, Time - 1:25.



DEFENSE AMMUNITION CENTER AND SCHOOL - SAVANNA, IL

Photo No. 1 (Polaroid) This photo shows that during testing stress cracks were observed in the plastic shield where it was attached to the APE 2245 model. After functioning two additional ignition cartridges, no propagation of the stress cracks were observed. It was concluded that the stress cracks were a product of the manufacturing of the shield and not caused by functioning the ignition cartridges.

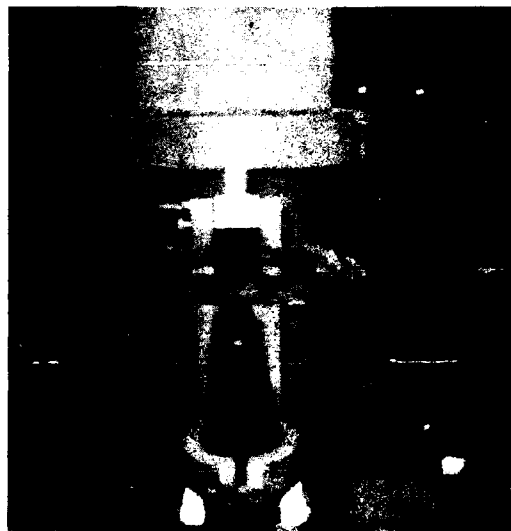

DEFENSE AMMUNITION CENTER AND SCHOOL - SAVANNA, IL

Photo No. 2 (Polaroid) This photo shows a close up of the flash tube clamp. The flash tube assembly has been removed. Note paint abrasion from functioning the ignition cartridge.



DEFENSE AMMUNITION CENTER AND SCHOOL - SAVANNA, IL
--

Photo No. 3 (Polaroid) This photo shows the holding fixture, inert mortar with the charged flash tube assembly prior to functioning. Retaining clamps are open for clarity. They are closed for the test. Mortar fire assembly removal tool is in the lower right hand corner of the photo.



DEFENSE AMMUNITION CENTER AND SCHOOL - SAVANNA, IL
--

Photo No. 4 (Polaroid) This photo shows the APE 2245 model positioned in the test bay. Note the heat flux and blast overpressure gages. The equipment is positioned for the last test.