

AAMRL-SR-90-513

AD-A241 203



2



SPATIAL DISORIENTATION RESEARCH ON THE DYNAMIC ENVIRONMENTAL SIMULATOR (DES)

William B. Albery, Ph.D.

Biodynamics and Bioengineering Division  
Harry G. Armstrong Aerospace Medical Research Laboratory

October 1990

DTIC  
ELECTE  
SEP 26 1991  
S D D

Final Report for the Period October 1988 to December 1989

91-11521



Approved for public release; distribution is unlimited

HARRY G. ARMSTRONG AEROSPACE MEDICAL RESEARCH LABORATORY  
HUMAN SYSTEMS DIVISION  
AIR FORCE SYSTEMS COMMAND  
WRIGHT-PATTERSON AIR FORCE BASE, OHIO 45433-6573

91 9 25 074

NOTICES

When US Government drawings, specifications, or other data are used for any purpose other than a definitely related Government procurement operation, the Government thereby incurs no responsibility nor any obligation whatsoever, and the fact that the Government may have formulated, furnished, or in any way supplied the said drawings, specifications, or other data, is not to be regarded by implication or otherwise, as in any manner licensing the holder or any other person or corporation, or conveying any rights or permission to manufacture, use, or sell any patented invention that may in any way be related thereto.

Please do not request copies of this report from the Harry G. Armstrong Aerospace Medical Research Laboratory. Additional copies may be purchased from:

National Technical Information Service  
5285 Port Royal Road  
Springfield VA 22161

Federal Government agencies and their contractors registered with Defense Technical Information Center should direct requests for copies of this report to:

Defense Technical Information Center  
Cameron Station  
Alexandria VA 22314

TECHNICAL REVIEW AND APPROVAL

AAMRL-SR-90-513

The voluntary informed consent of the subjects used in this research was obtained as required by Air Force Regulation 169-3.

This report has been reviewed by the Office of Public Affairs (PA) and is releasable to the National Technical Information Service (NTIS). At NTIS, it will be available to the general public, including foreign nations.

This technical report has been reviewed and is approved for publication.

FOR THE COMMANDER

*Peter A. Lurker*

PETER A. LURKER, Lt Col, USAF BSC  
Acting Director  
Biodynamics & Bioengineering Division  
Harry G. Armstrong Aerospace Medical Research Laboratory



Available For	
NTIS GRA&I	J
DTIC TAB	
Unannounced	
Justification	
By	
Date	
Availability Codes	
Dist	Available for Special
A-1	

REPORT DOCUMENTATION PAGE			Form Approved OMB No 0704-0188	
Public reporting burden for this collection of information is estimated to average 1 hour per response, including the time for reviewing instructions, searching existing data sources, gathering and maintaining the data needed, and completing and reviewing the collection of information. Send comments regarding this burden estimate or any other aspect of this collection of information, including suggestions for reducing this burden, to Washington Headquarters Services, Directorate for Information Operations and Reports, 1215 Jefferson Davis Highway, Suite 1204, Arlington, VA 22202-4302 and to the Office of Management and Budget, Paperwork Reduction Project (0704-0188), Washington, DC 20503				
1. AGENCY USE ONLY (Leave blank)	2. REPORT DATE October 1990	3. REPORT TYPE AND DATES COVERED Final Report Oct 88 to Dec 89		
4. TITLE AND SUBTITLE  Spatial Disorientation Research on the Dynamic Environmental Simulator (DES)		5. FUNDING NUMBERS  PE: 62201F PR: 7231 TA: 25 WU: D2		
6. AUTHOR(S)  William B. Albery, Ph.D.		7. PERFORMING ORGANIZATION NAME(S) AND ADDRESS(ES) Harry G. Armstrong Aerospace Medical Research Laboratory, Biodynamics & Bioengineering Div. HSD, AFSC Wright-Patterson AFB, OH 45433-6573		
8. PERFORMING ORGANIZATION REPORT NUMBER  AAMRL-SR-90-513		9. SPONSORING/MONITORING AGENCY NAME(S) AND ADDRESS(ES)		
10. SPONSORING/MONITORING AGENCY REPORT NUMBER		11. SUPPLEMENTARY NOTES		
12a. DISTRIBUTION/AVAILABILITY STATEMENT  Approved for public release; distribution is unlimited.		12b. DISTRIBUTION CODE  A		
13. ABSTRACT (Maximum 200 words) Spatial Disorientation (SD) is a serious human factors problem in both the Air Force and Navy. Over 70 Class A mishaps involving nearly total loss of an aircraft or death of the pilot have been attributed to SD in the U.S. Air Force alone since 1980. Many of these SD related fatalities involve low-level turning mishaps in which the pilot is moving his head and the aircraft is at greater than 1G. The G excess illusion, an altered perception of one's attitude when G 1, is a potential player in many of these low-level turning mishaps. The purpose of this study was to assess the potential of the Dynamic Environment Simulator, a 20 ft radius, dual-gimballed, human centrifuge to generate vestibular related SD illusions, especially, the G-excess illusion. In this pilot study, the effects of head position and acceleration up to 3 G were investigated on subjects' perception of vertical. It was observed that one's error in subjective vertical increased as a function of both increasing acceleration (Gz) and increasing angle between true vertical and the resultant gravito-inertial force.				
14. SUBJECT TERMS  Biological and Medical Sciences			15. NUMBER OF PAGES  7	
16. PRICE CODE			17. SECURITY CLASSIFICATION OF REPORT  UNCLASSIFIED	
18. SECURITY CLASSIFICATION OF THIS PAGE  UNCLASSIFIED		19. SECURITY CLASSIFICATION OF ABSTRACT  UNCLASSIFIED		20. LIMITATION OF ABSTRACT  UNLIMITED

## PREFACE

The research described in this special report was made possible by the Harry G. Armstrong Aerospace Medical Research Laboratory (AAMRL) In-House Laboratory Independent Research (ILIR) Program. Fiscal year 88 funds were provided under element 61101F, work unit 723125D2. This research was completed as partial fulfillment of the requirements for the Degree of Master of Science, Aerospace Medicine, Department of Community Medicine, Wright State University, School of Medicine, for Sangkun "Sonny" Park, MD.

Dr Park helped conduct this research which resulted in a 1989 Master's Thesis entitled "Modification of Attitude Perception as a Function of Head Position and G." This research also paved the way for follow-on research sponsored by AFOSR involving a more in-depth investigation of the G-excess effect on the Dynamic Environment Simulator at Wright-Patterson Air Force Base.

Objective: The objective of this research was to assess the feasibility of using the Dynamic Environment Simulator (DES), a dual-gimballed human centrifuge, to conduct spatial disorientation (SD) research. The first objective of this SD research was to demonstrate in subjects the G-excess effect, an exaggerated sensation of body tilt that occurs when applied G-force on the vestibular system is greater than 1 G.

Approach: Nine centrifuge panel subjects participated in the study which was accomplished in the darkened cab of the DES (Figure 1). In experiment I, subjects were first trained to estimate their perception of down at 1 G while the DES cab was randomly placed at several different angles off of vertical (+/-120 degrees, +/-90 degrees, +/-60 degrees and +/-30 degrees). Subjects directed an arrow displayed on a TV monitor directly in front of them to their perception of "down" during these randomized cab positions. Subjects used a control dial to position the direction of the arrow (Figure 2). Five of the nine original subjects then participated in experiments II and III. Their results were the most consistent during 1 G trials. The approach in experiment II was to repeat the trials previously performed at 1 G in experiment I, but at 2.0, 2.5 and 3 Gz. In experiment III, subjects repeated experiment II, but performed the task with the CRT at an offset angle, to simulate a formation flying head/acceleration configuration (Figure 3).

Results: Interactions of head position (straight ahead or offset by 31 degrees yaw left and 45 degrees pitch up) and Gz as well as Gz vs the head angle were observed (Figure 4). Mean perceived attitudes with head straight ahead and head offset for 1 Gz to 3 Gz showed that when the head is offset, subjects demonstrated greater error in estimating the direction of the net gravitoinertial force, or "down" arrow (Figure 5). Furthermore, the G-excess effect appears to be present at G levels greater than 2.0 Gz.

Discussion: This research confirmed previous work by other researchers that the G-excess effect can be observed in a centrifuge-like device, where a sustained  $G > 1$  can be developed. Previous research on this illusion had been limited to 2.0 G principally because of the limitations of the device used. Of interest here was the observation that the effect is still present at 2.5 and 3.0 Gz. Future research will concentrate on head positions in addition to the two investigated here (straight ahead and offset) as well as higher G levels.

Conclusion: It was demonstrated that the DES can be used to conduct spatial disorientation research. Because of its computer controlled gimbals, the DES cab and its occupant can be placed at precise orientations and sustained accelerations. In this preliminary research, it was found that the G-excess effect can be generated in the DES. Subjects performed a visual attitude perception task with the head fixed looking straight ahead and with the head yawed left 31 degrees and pitched up 45 degrees. Subjective errors in the direction of the gravitoinertial force tended to increase as a function of increasing G, body tilt, and head position.

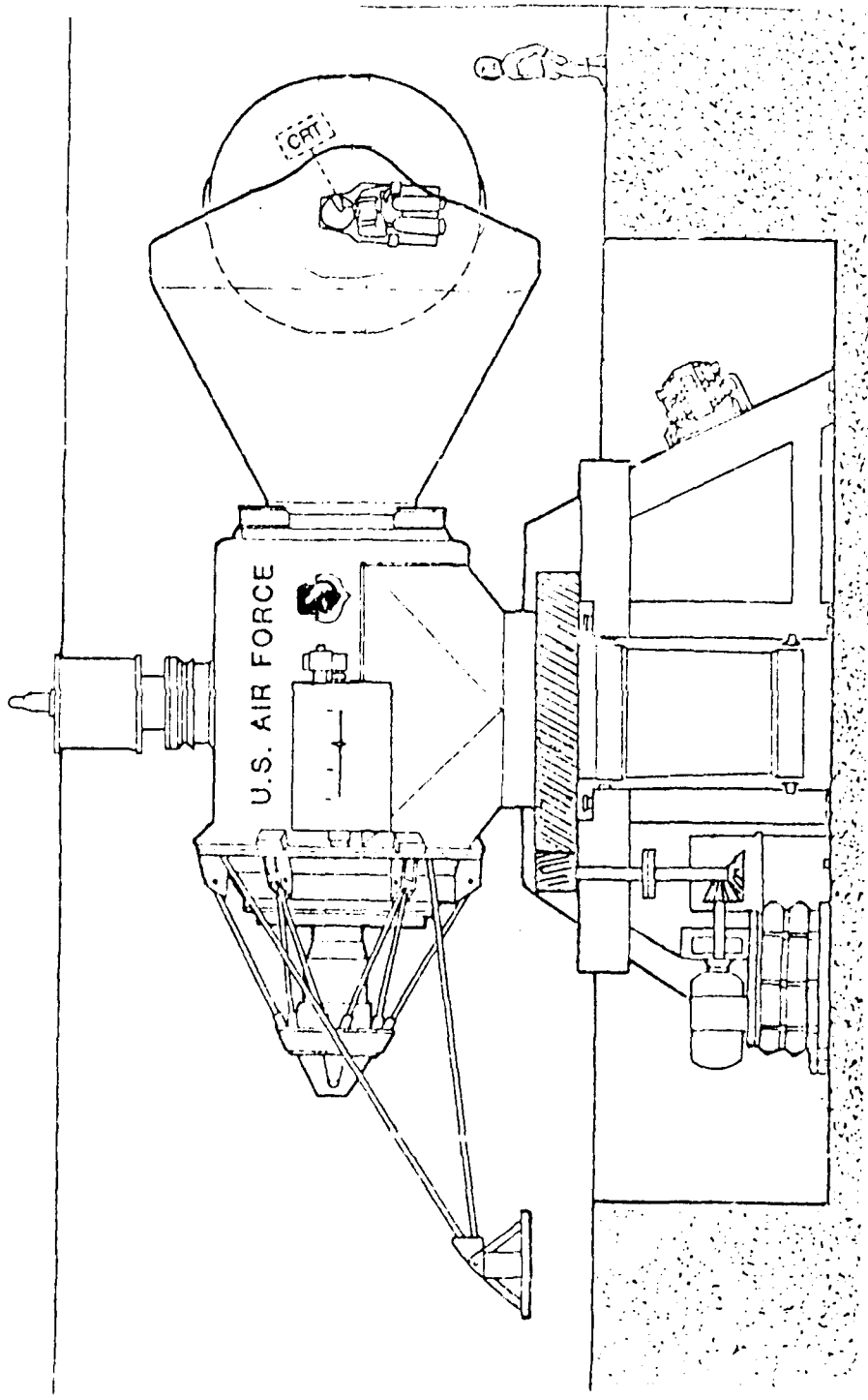

Figure 1. SPATIAL DISORIENTATION RESEARCH & DES  
CONDOLA AT WPAFB, DAYTON, OHIO

Figure 2. EXPERIMENTAL DESIGN IN DES GONDOLA

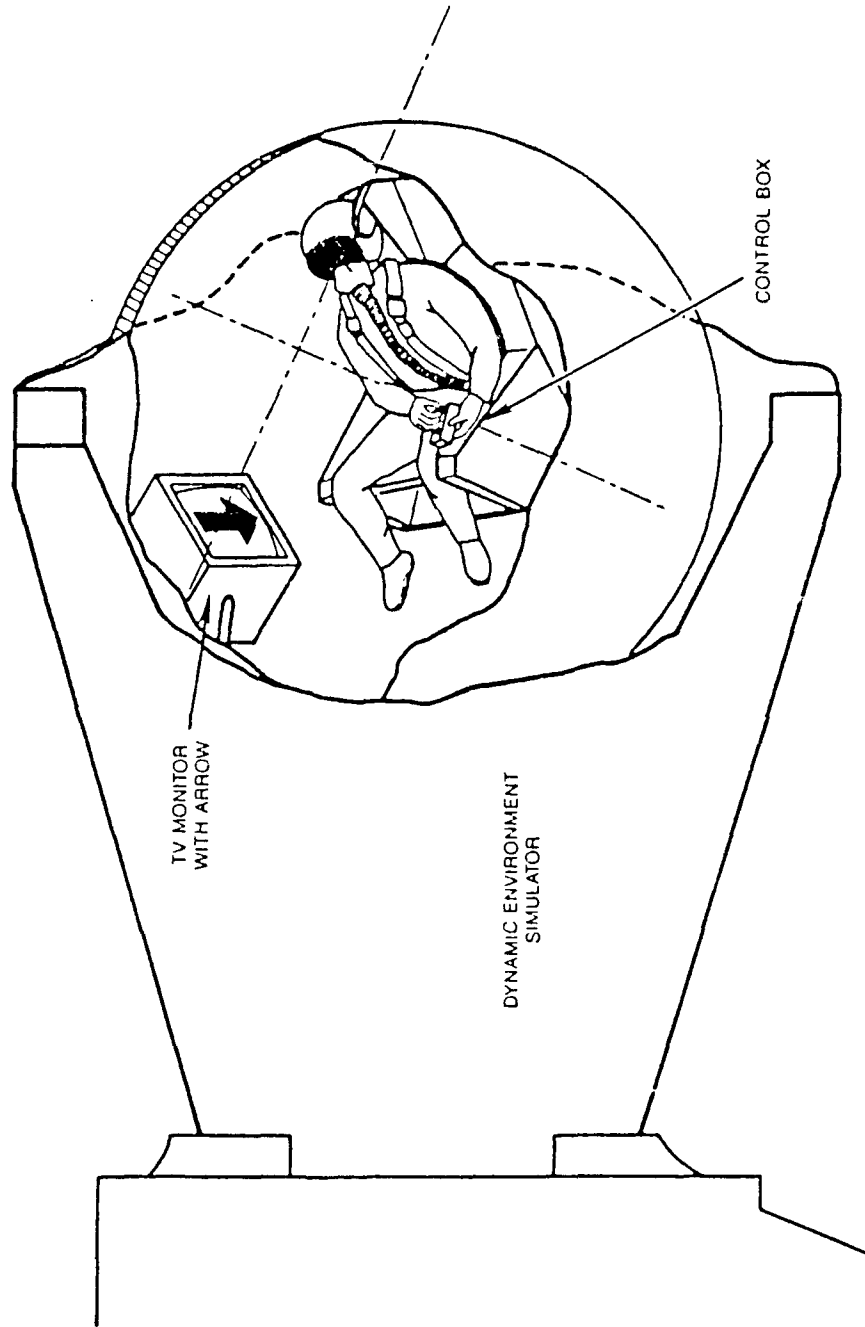
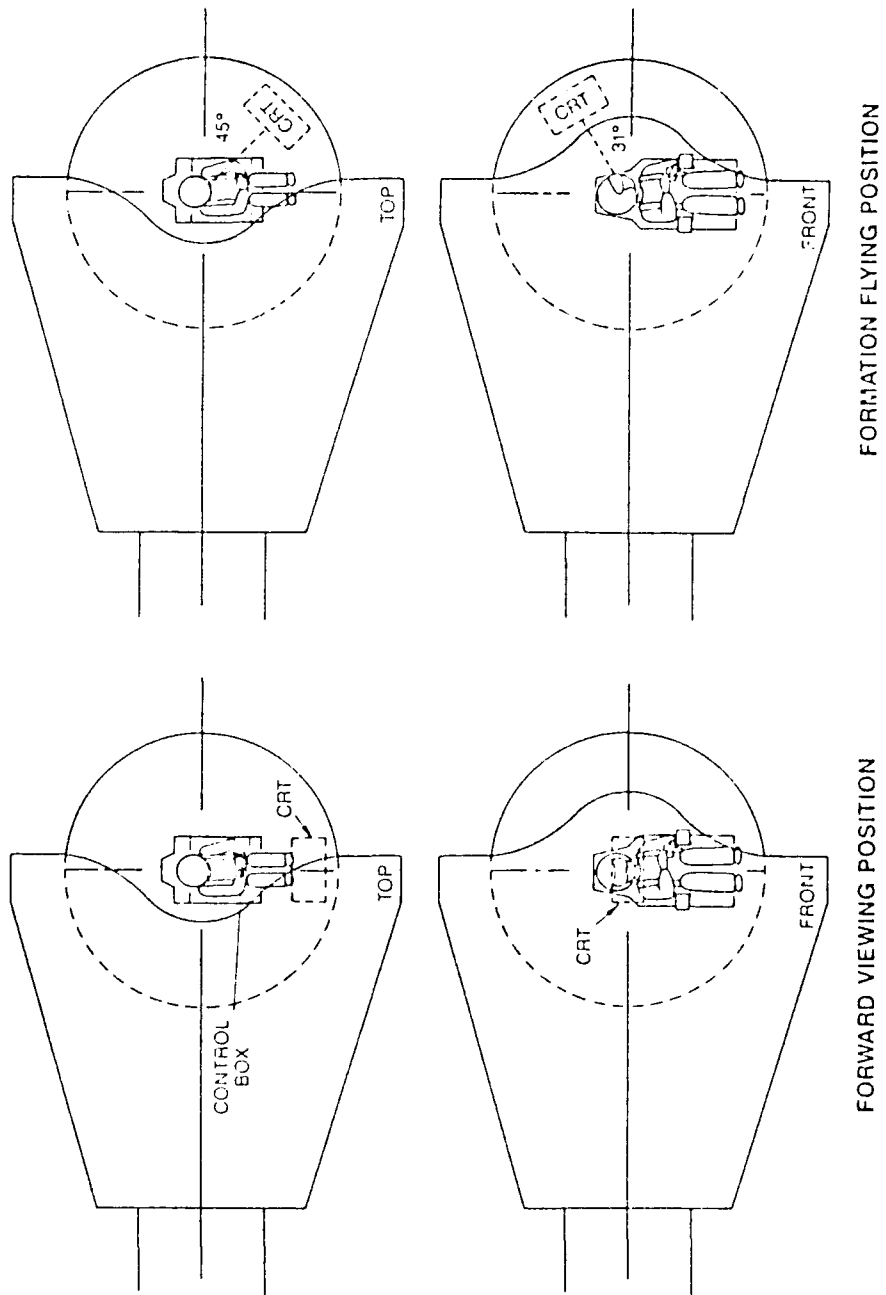

FIGURE 3. HEAD POSITIONS IN THE DYNAMIC ENVIRONMENT SIMULATOR



FORMATION FLYING POSITION

EXPERIMENT III

FORWARD VIEWING POSITION

EXPERIMENT II

MEAN PERCEIVED ANGLE (N=5)

--- = STRAIGHT — = OFFSET

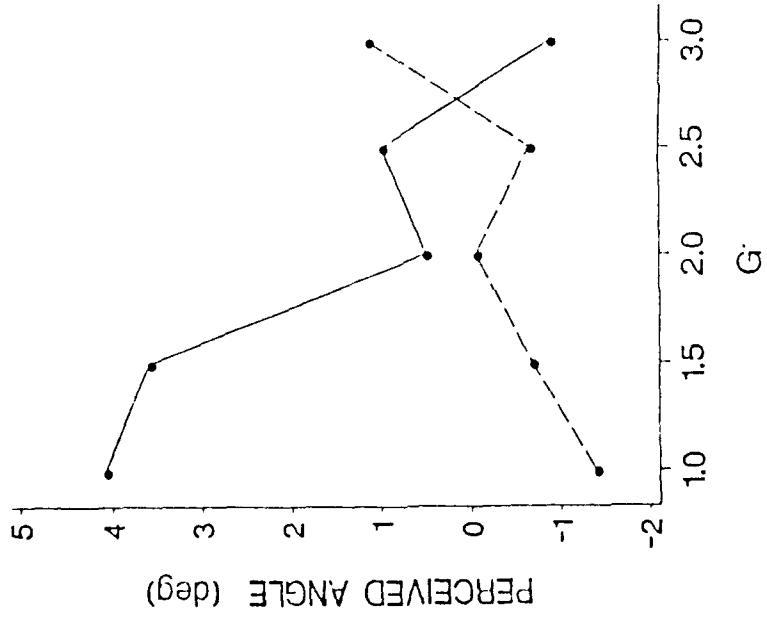

MEAN ERROR (N=5)

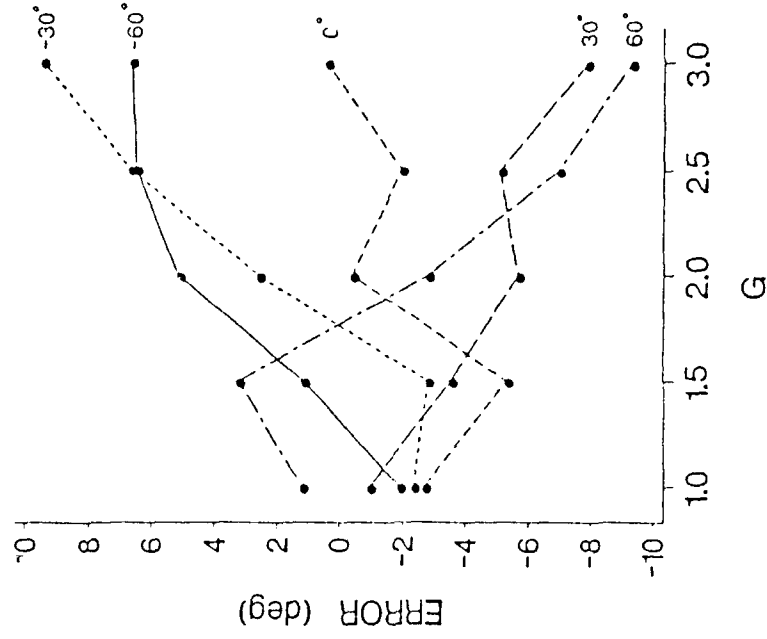

Figure 4. INTERACTIONS OF HEAD POSITION vs. Gz AND Gz vs ANGLE ( Gz Value applies to angle of 0 degree )

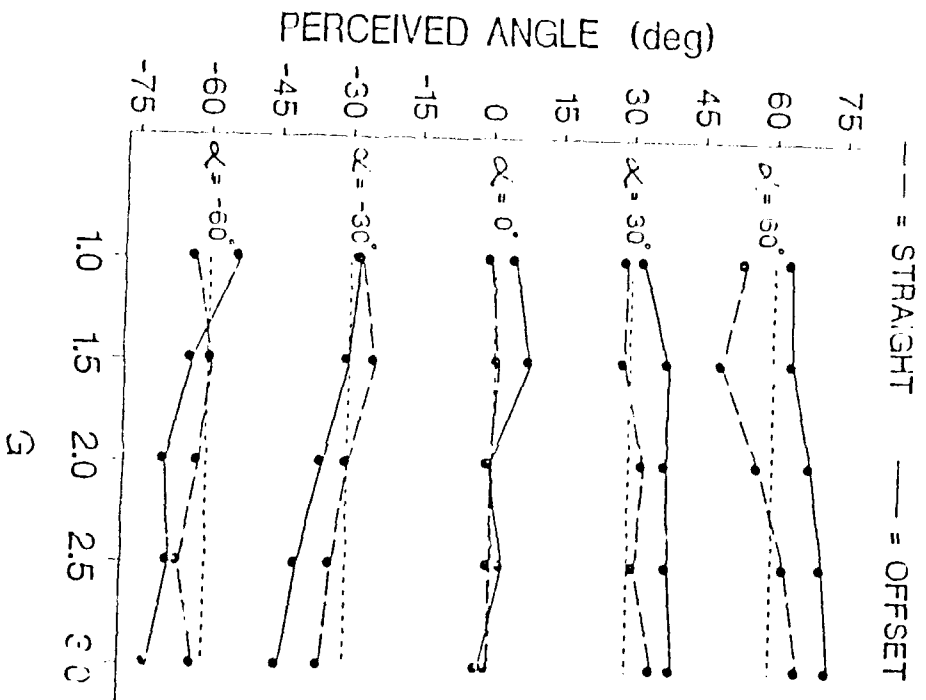

Figure 5. MEAN PERCEIVED ANGLES OF HEAD STRAIGHT AND HEAD OFFSET ( Gz values apply to  $\alpha=0$  )