

AD-A241 405



TECHNICAL REPORT HL-91-12

2

SUBMERSIBLE-TYPE TAITER GATE FOR SPILLWAY, PEORIA LOCK AND DAM

Hydraulic Model Investigation

by

Deborah R. Cooper

Hydraulics Laboratory

DEPARTMENT OF THE ARMY

Waterways Experiment Station, Corps of Engineers
3909 Halls Ferry Road, Vicksburg, Mississippi 39180-6199

DTIC
ELECTE
OCT 10 1991
S D D



July 1991

Final Report

Approved For Public Release; Distribution Unlimited

91-12948



Prepared for US Army Engineer District, Rock Island
Rock Island, Illinois 61204-2004

01 10 0 040

US Army Corps
of Engineers

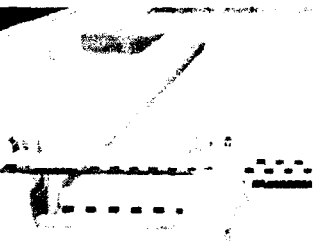
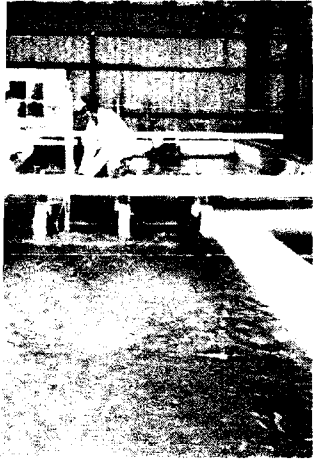

HYDRAULICS
LABORATORY

DISCLAIMER NOTICE

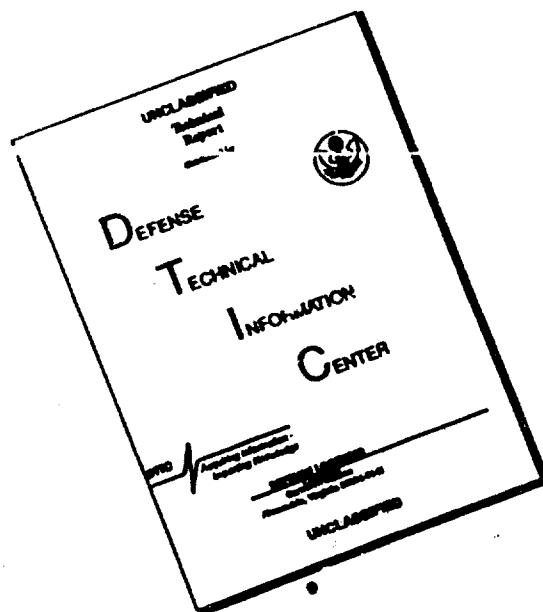

THIS DOCUMENT IS BEST QUALITY AVAILABLE. THE COPY FURNISHED TO DTIC CONTAINED A SIGNIFICANT NUMBER OF PAGES WHICH DO NOT REPRODUCE LEGIBLY.

Destroy this report when no longer needed. Do not return
it to the originator.

The findings in this report are not to be construed as an official
Department of the Army position unless so designated
by other authorized documents.

The contents of this report are not to be used for
advertising, publication, or promotional purposes.
Citation of trade names does not constitute an
official endorsement or approval of the use of
such commercial products.

REPORT DOCUMENTATION PAGE

Form Approved
OMB No. 0704-0188

Public reporting burden for this collection of information is estimated to average 1 hour per response, including the time for reviewing instructions, searching existing data sources, gathering and maintaining the data needed, and completing and reviewing the collection of information. Send comments regarding this burden estimate or any other aspect of this collection of information, including suggestions for reducing this burden, to Washington Headquarters Services, Directorate for Information Operations and Reports, 1215 Jefferson Davis Highway, Suite 1204, Arlington, VA 22202-4302, and to the Office of Management and Budget, Paperwork Reduction Project (0704-0188), Washington, DC 20503.

1. AGENCY USE ONLY (Leave blank)	2. REPORT DATE July 1991	3. REPORT TYPE AND DATES COVERED Final report
---	------------------------------------	---

4. TITLE AND SUBTITLE Submersible-Type Tainter Gate for Spillway Peoria Lock and Dam; Hydraulic Model Investigation	5. FUNDING NUMBERS
--	---------------------------

6. AUTHOR(S) Deborah R. Cooper	7. PERFORMING ORGANIZATION NAME(S) AND ADDRESS(ES) USAE Waterways Experiment Station, Hydraulics Laboratory, 3909 Halls Ferry Road, Vicksburg, MS 39180-6199
--	--

8. PERFORMING ORGANIZATION REPORT NUMBER Technical Report HL-91-12	9. SPONSORING / MONITORING AGENCY NAME(S) AND ADDRESS(ES) US Army Engineer District, Rock Island, PO Box 2004, Rock Island, IL 61204-2004
---	--

10. SPONSORING / MONITORING AGENCY REPORT NUMBER	11. SUPPLEMENTARY NOTES Available from National Technical Information Service, 5285 Port Royal Road, Springfield, VA 22161.
---	--

12a. DISTRIBUTION AVAILABILITY STATEMENT Approved for public release; distribution unlimited.	12b. DISTRIBUTION CODE
---	-------------------------------

13. ABSTRACT (Maximum 200 words) A 1:20-scale hydraulic model initially simulated forty-seven 4-ft-wide wicket gates, three 8-ft-wide piers, the 923-ft-long lock wall, two freely suspended 60-ft-wide by 11-ft-high submersible tainter gates, the 50-ft-long stilling basin and basin elements, 477 ft of the upstream approach, and 1,000 ft of the exit channel. During testing the initial design was modified to simulate one 84-ft-wide by 16-ft-high freely suspended submersible tainter gate, two 12-ft-wide piers, fifty-eight 4-ft-wide wicket gates, the 923-ft-long lock wall, a 131.25-ft-long stilling basin and basin elements, 477 ft of the upstream approach and 1,000 ft of the exit channel. Riprap protection requirements were also determined upstream and downstream of the structure. Construction conditions such as protection of the cofferdam were examined. The gate lifting mechanism consisted of a cable at each end of the gate attached to load cells. The magnitude and frequency of the forces acting on the cable supporting each end of the gate were measured. Tests indicated little likelihood of	
--	--

(Continued)

14. SUBJECT TERMS Hydraulic forces Vibrations Spillway Wicket dam Submersible gates	15. NUMBER OF PAGES 81
17. SECURITY CLASSIFICATION OF REPORT UNCLASSIFIED	16. PRICE CODE

18. SECURITY CLASSIFICATION OF THIS PAGE UNCLASSIFIED	19. SECURITY CLASSIFICATION OF ABSTRACT	20. LIMITATION OF ABSTRACT
---	--	-----------------------------------

13. ABSTRACT (Continued)

the cables being subjected to exciting forces occurring at a periodic frequency with flow either over or under the subject gate in its normal operating range. Discharge characteristics and coefficients with various operating scenarios were determined.

PREFACE

The model investigation reported herein was authorized by the Headquarters, US Army Corps of Engineers (HQUSACE), on 8 October 1985 at the request of the US Army Engineer District, Rock Island.

The studies were conducted in the Hydraulics Laboratory (HL) of the US Army Engineer Waterways Experiment Station (WES) during the period October 1985 to May 1987 under the direction of Messrs. F. A. Herrmann, Jr., Chief of the Hydraulics Laboratory; R. A. Sager, Assistant Chief of the Hydraulics Laboratory; and J. L. Grace and G. Pickering, former and present Chiefs of the Hydraulic Structures Division (HSD), HL. The tests were conducted by Mmes. P. R. Cooper and J. A. Flowers and Messrs. E. L. Jefferson and R. Bryant, Jr., of the Spillways and Channels Branch, HSD, under the direct supervision of Mr. N. R. Oswalt, Chief of the Spillways and Channels Branch. This report was prepared by Mrs. Cooper.

During the course of the investigation Messrs. J. Ordonez, L. Hiipakka, and B. Snowden of the US Army Engineer Division, North Central; and S. K. Nanda, D. McCully, W. Parr, D. Logsdon, E. Leuch, C. Johnson, D. Wehrley, and J. Schliekelman of the Rock Island District visited WES to discuss test results and correlate these results with current design studies.

Mr. Ed Case, Engineering and Construction Services Division, WES, constructed the gate. Mrs. Marsha Gay, Information Technology Laboratory, WES, edited this report.

Commander and Director of WES during preparation of this report was COL Larry B. Fulton, EN. Technical Director was Dr. Robert W. Whalin.

Accession For	
NTIS CRARI	J
DTIC TAB	11
Unannounced	12
Justification	
By	
Distribution	
Availability	
Dist	Availability
A-1	

CONTENTS

	<u>Page</u>
PREFACE.....	1
CONVERSION FACTORS, NON-SI TO SI (METRIC) UNITS OF MEASUREMENT.....	3
PART I: INTRODUCTION.....	4
The Prototype.....	4
Purpose and Scope of the Model Study.....	5
Presentation of Data.....	6
PART II: THE MODEL AND TEST PROCEDURE.	7
Description.....	7
Appurtenances and Instrumentation.....	10
Scale Relations.....	10
Test Procedure.....	11
PART III: TESTS AND RESULTS.....	13
Discharge Characteristics.....	13
Stilling Basin.....	18
Riprap Requirements.....	20
Gate Cable Loads and Vibrations.....	23
PART IV: CONCLUSIONS.....	26
TABLES 1-5	
PHOTOS 1-4	
PLATES 1-41	

CONVERSION FACTORS, NON-SI TO SI (METRIC)
UNITS OF MEASUREMENT

Non-SI units of measurement used in this report can be converted to SI (metric) units as follows:

<u>Multiply</u>	<u>By</u>	<u>To Obtain</u>
cubic feet	0.02831685	cubic metres
degrees (angular)	0.01745329	radians
feet	0.3048	metres
inches	25.4	millimetres
miles (US statute)	1.609344	kilometres
pounds (mass)	0.4535924	kilograms
pounds (mass) per cubic foot	16.01846	kilograms per cubic metre
square feet	0.09290304	square metres
tons (short, 2,000 lb)	907.1847	kilograms

SUBMERSIBLE-TYPE TAINTER GATE FOR SPILLWAY, PEORIA

LOCK AND DAM, ILLINOIS RIVER, ILLINOIS

Hydraulic Model Investigation

PART I: INTRODUCTION

The Prototype

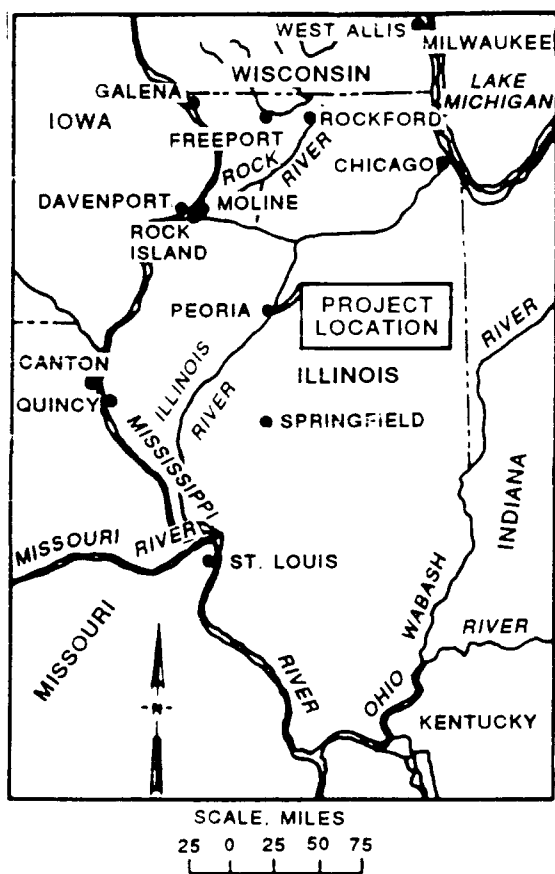

Figure 1. Location map

1. Peoria Dam is located 157.7 miles* above the mouth of the Illinois River, a few miles downstream of the city of Peoria, IL (Figure 1).

2. The dam maintains the 73-mile-long navigation pool between the Peoria and Starved Rock Locks and Dams. Normal upper pool elevation for Peoria is 440.0.** The minimum tailwater elevation is 429.0.

3. The spillway section of the dam consists of a low sill (el 424.6) surmounted by one hundred thirty-four 4-ft-wide wicket gates, located within the main channel of the waterway (Plate 1). Energy is dissipated with baffle blocks on a horizontal apron terminated with an end sill.

4. A unique feature of a wicket dam is the capability of lowering the wickets during high flows allowing river traffic to pass over the dam, bypassing the lock (Photo 1). Each wicket has only two stationary positions--the raised and the lowered position (Plate 2).

* A table of factors for converting non-SI units of measurement to SI (metric) units of measurements is presented on page 3.

** All elevations (el) and stages cited herein are in feet referred to the National Geodetic Vertical Datum (NGVD).

With low riverflows, all of the wickets must be raised and the water passes through the 3-in.-wide gaps between wickets. Since the normal pool elevation is even with the top of the raised wickets, ice and debris cannot pass through the wicket dam with the wickets raised. Backed-up ice can cause several operational problems. Frequently during the winter, ice lockages are required to move large quantities of ice through while tows wait for a clear lock.

5. Flow regulation at Peoria Lock and Dam with the wickets was undesirable. The lowered wickets passed a column of water that caused downstream scour. In addition, the wickets could not be efficiently raised and lowered as flows changed.

6. To alleviate some of the problems of the wicket dam, 26 wickets adjacent to the lock wall were replaced by an 84-ft-wide submersible tainter gate and two concrete piers. The new gate was designed to pass water under the gate (Photo 2), or over the gate with a maximum 8 ft of gate submergence (Photo 3). During high flows, the gate may be raised completely out of the water. The prototype gate has been constructed and is operational. Model testing preceded the construction of the prototype. The gate and piers are located just upstream of the existing concrete wicket sill along the lock wall.

7. The submergence feature of the gate permits skimming ice and debris over the top of the gate with a much smaller water discharge than would be required to draw the material under a nonsubmersible type gate. Flow sufficient to skim floating material over the top of a submerged gate produces less violent downstream effects.

Purpose and Scope of the Model Study

8. Because Corps submersible gates on the Ohio River have historically experienced severe vibrations,* this model study was conducted to determine the magnitude and frequency of the hydraulic forces acting on the lifting cables while the gate is submerged. In addition, verification of anticipated stilling basin performance through the full range of operation of the existing wicket gates and the then-proposed submersible tainter gate, determination of

* US Army Engineer District, Louisville. 1985 (Jun). "Submergible Gate Use Within the Corps: Case Histories," Louisville, KY.

the extent of scour and the need for protection upstream and downstream of the structure, and passage of ice were of interest. Discharge characteristics and coefficients with various operating scenarios were determined from the model.

Presentation of Data

9. In the presentation of test results, no attempt is made to introduce the data in the chronological order in which the tests were conducted on the model. Instead, as each element of the structure is considered, all tests conducted thereon are discussed in detail. All model data are presented in terms of prototype equivalents. All tests are discussed in Part III.

PART II: THE MODEL AND TEST PROCEDURE

Description

Type 1 design

10. Initially the 1:20-scale model (Figure 2) reproduced two 60-ft-wide by 11-ft-high submersible tainter gates with a 30-ft radius, three 8-ft-wide piers, forty-seven 4-ft-wide wicket gates, the 923-ft-long lock wall, the 50-ft-long stilling basin and basin elements, 477 ft of the upstream approach, and 1,000 ft of the exit channel (Figure 2 and Plate 3). The model tainter gates were constructed of sheet metal. The upstream and downstream skin plates and trunnion arms were reproduced to scale. The rubber side seals were omitted, creating a 2-in. (prototype) gap between the gate and the piers (hereafter referred to as side gaps) that does not exist in the prototype. To reduce friction forces to a minimum, the gate trunnions were mounted in roller bearings in the adjacent piers. The gate to sill clearance simulated was 1 in. The lock wall and miter gates were constructed of plywood; and the piers, spillway, stilling basin, and wicket gates were constructed of plastic. The gate lifting mechanism consisted of a cable at each end of each gate suspended by a pulley system. Each model cable was sized to reproduce the elastic properties of four prototype cables proposed for each end of each gate. The portions of the model representing the approach and exit channels were molded in sand. The original design is referred to as the type 1 design structure.

Type 2 design

11. Due to apparent navigation hazards with the type 1 design (as indicated in a navigation model study), the type 1 design model was modified to the type 2 design (Figure 3). With modifications, the model reproduced one 84-ft-wide by 16-ft-high submersible tainter gate with a 30-ft radius, two 12-ft-wide piers, fifty-eight 4-ft-wide wicket gates, the gate lifting cables, the 923-ft-long lock wall, the 43.5-ft-long stilling basin and basin elements, 477 ft of the upstream approach, and 1,000 ft of the exit channel (Plate 4). The submersible model gate was constructed of brass and simulated a prototype gate weighing 126 tons (dry weight). Rubber side seals were omitted, creating a 2-in. (prototype) gap between the gate and the piers that does not exist in the prototype. To reduce friction forces to a minimum, the gate trunnions



a. Upstream view

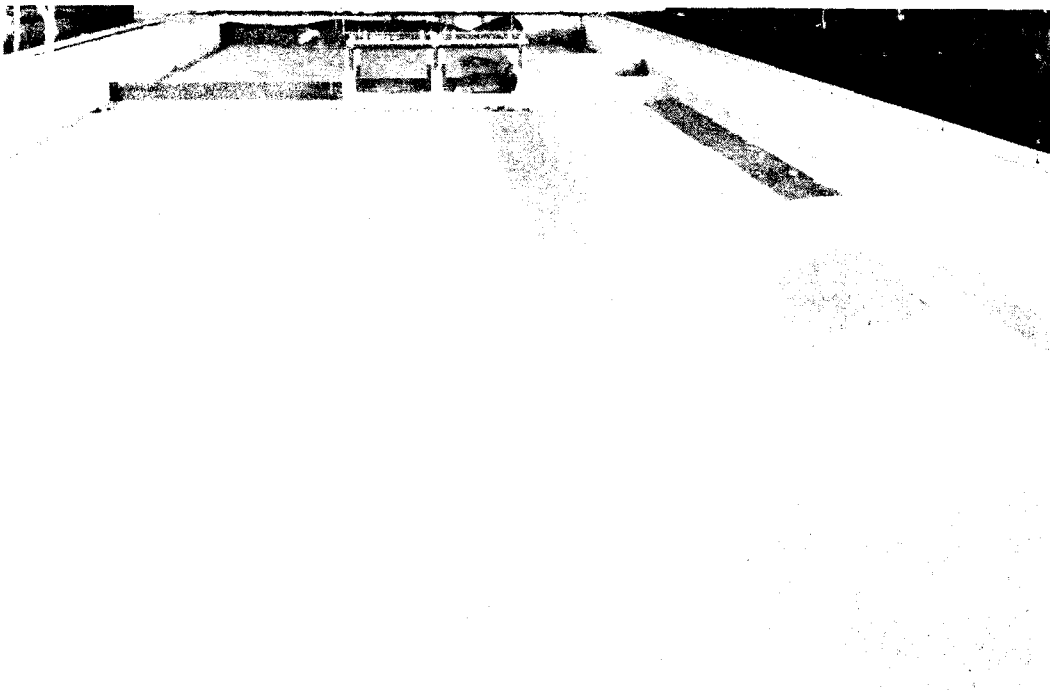

b. Downstream view

Figure 2. 1:20-scale type 1 (original) design structure



Figure 3. Type 2 design structure, upstream view

were mounted in roller bearings in the adjacent piers. The gate to sill clearance simulated was 1 in. The gate lifting mechanism consisted of a cable at each end of the gate attached to a load cell suspended by a pulley system. Each model cable was sized to reproduce the elastic properties of four prototype cables proposed for each end of the gate. The lock wall and miter gates were constructed of plywood; and the piers, spillway, stilling basin, and wicket gates were constructed of plastic.

Type 3 design

12. During the final design of the prototype cofferdam, dewatering considerations necessitated a design change. The gate was located 71.8 ft upstream of the existing wicket sill, making the stilling basin longer (Figure 4) and facilitating the construction of the cofferdam. The cofferdam could then be installed in the riverbed instead of in the concrete apron. The type 3 design structure (Plate 5) incorporated the type 2 design spillway crest and the type 2 design gate (one 84-ft-wide gate). The stilling basin length was increased to 131.35 ft (which included the existing wicket sill and the 43.5-ft-long existing wicket stilling basin).

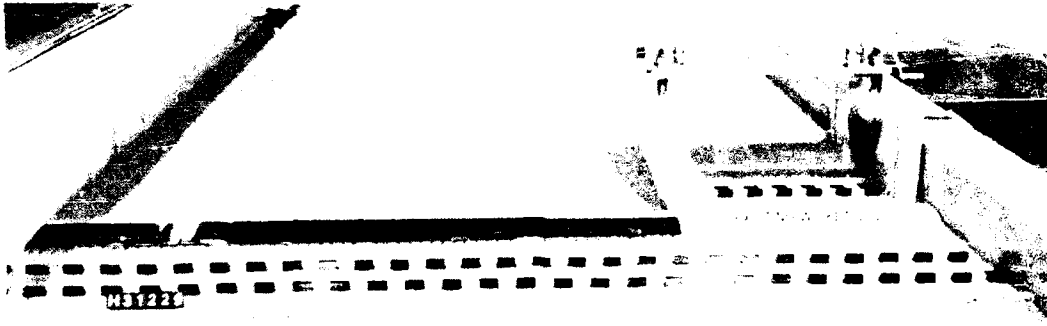

Figure 4. Type 3 design structure, downstream view (wickets down)

Appurtenances and Instrumentation

13. Water used in the operation of the model was supplied by pumps, and discharges were measured with venturi meters. The tailwater in the downstream end of the model was controlled by an adjustable tailgate. Steel rails set to grade provided reference planes. Water-surface elevations were obtained with point gages. Velocities were measured with a pitot tube. Load cells and an oscillograph recorder (Figure 5) were used to measure and record the magnitude and frequency of the total forces acting on each end of the gate. Chart speed used during testing was 1 inch per second (ips).

Scale Relations

14. The accepted equations of similitude, based upon the Froudian relations, were used to express the mathematical relations between the dimensions and hydraulic quantities of the model and the prototype. General relations

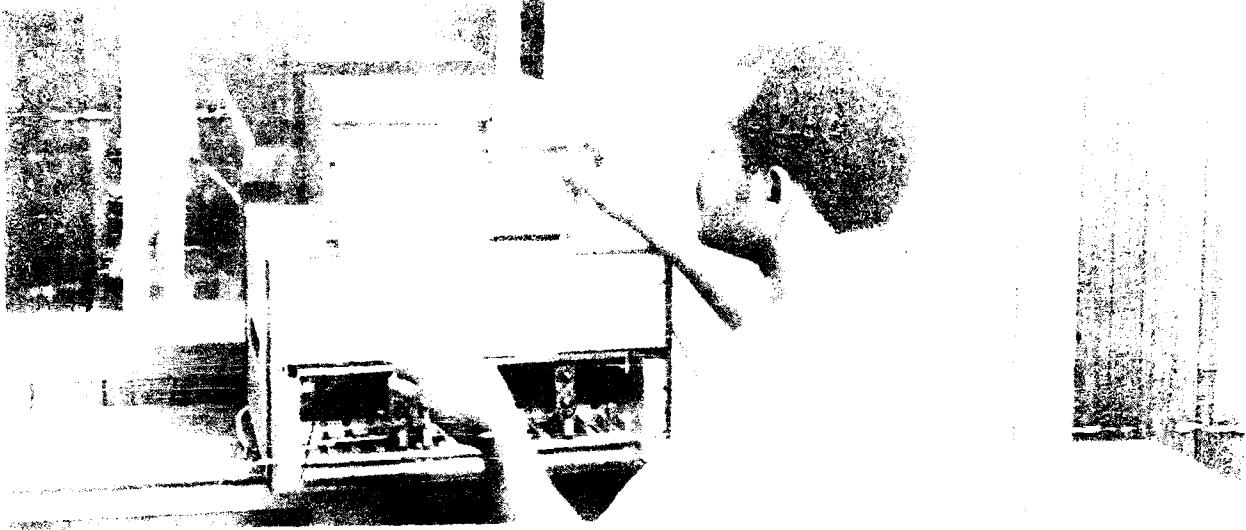

Figure 5. Oscillograph recorder

for the transference of model data to prototype equivalents are presented in the following tabulation:

<u>Dimension</u>	<u>Ratio</u>	<u>Scale Relation</u> <u>Model:Prototype</u>
Length	$L_r = L$	1:20
Area	$A_r = L_r^2$	1:400
Velocity	$V_r = L_r^{1/2}$	1:4.472
Discharge	$Q_r = L_r^{5/2}$	1:1,788.85
Time	$T_r = L_r^{1/2}$	1:4.472
Weight	$W_r = L_r^3$	1:8,000
Force	$F_r = L_r^3$	1:8,000

Test Procedure

The tests were conducted in the model to observe the conditions with flow over and under the gate, and to determine the magnitude and frequency of the hydrodynamic forces acting on the lifting cables with various gate opening and sedimentation of the gate. In measuring the forces on the gate, the point of application was determined, and while the position of the gate and the tank water were studied.

16. All tests were conducted with the upper pool level maintained at a constant elevation of 440.0. Prior to the start of a test, the force-measuring equipment was checked to ensure that it was working properly, the moving parts of the test gate were examined, and the water levels of the upper pool and the lower pool below the gate were properly adjusted. The force-measuring device, having been previously zeroed, was then placed in operation (raising or lowering the test gate). The force on the hoisting cables was measured by raising the crest of the gate in 1-ft increments to a desired elevation and holding it there for a measurement. All force data presented in tables were measured in this manner.

PART III: TESTS AND RESULTS

Discharge Characteristics

Wickets

17. Tests were conducted to determine the discharge characteristics for flow through the wickets. Various constant discharges were introduced into the model, the tailwater was set, and the upper pool was allowed to stabilize. The pool elevation was recorded and the tailwater was then varied. During these tests all leakage through raised wickets was sealed in the model. Basic calibration data obtained for flow through 10, 15, 20, 25, 30, and 47 wickets are presented in plots of upper pool elevation versus tailwater elevation in Plate 6. Plate 7 shows the effect of tailwater elevation on discharge for various multiples of wickets. These plots were derived from the basic data.

Spillway

18. Tests were conducted with two different spillway crest designs incorporated in three different structure designs for the submersible-gated spillway. These designs, furnished by the sponsor, differed in approach slope, crest height, length, and location in reference to the existing wicket dam axis. The type 1 design (Plate 3) had a 1V on 1H sloping upstream face and a 10-ft-long flat crest 6 ft above the approach floor elevation surmounted by two 60-ft-wide submersible tainter gates. The center line of the crest was located 7.45 ft downstream of the wicket dam axis. The type 2 design structure (Plate 4) had a 1V on 9H sloping upstream face and a 2-ft-long flat crest 2 ft above the approach floor elevation surmounted by one 84-ft-wide submersible tainter gate. The center line of the crest was located 15.95 ft downstream of the existing wicket dam axis. The type 3 design structure (Plate 5) incorporated the type 2 design crest shape located upstream of the wicket dam axis. The crest center line was located 71.8 ft upstream of the existing wicket dam axis.

Flow conditions

19. Tests to determine the discharge characteristics of the spillway with the two spillway crest designs were conducted for each of the following flow conditions. The term submerged in this discussion of flow conditions describes the submergence effect of the tailwater and not the submergence effect of the gate.

- a. Free uncontrolled flow. Gate fully open; upper pool unaffected by the tailwater.
- b. Submerged uncontrolled flow. Gate fully open; upper pool controlled by the submergence effect of the tailwater.
- c. Free uncontrolled flow (over the gate). Gate in submerged position with flow over the gate; upper pool unaffected by the tailwater. Gate behaves as a weir (fixed at several elevations).
- d. Submerged uncontrolled flow (over the gate). Gate in submerged position with flow over the gate; upper pool controlled by the submergence effect of the tailwater. Gate behaves as a weir (fixed at several elevations)
- e. Free controlled flow. Gate partially open; upper pool unaffected by the tailwater; flow controlled by the particular gate opening with flow under the gate.
- f. Submerged controlled flow. Gate partially open; upper pool controlled by both the submergence effect of the tailwater and the gate opening with flow under the gate.

These flow regimes are shown in Plate 8. Symbols used in this plate are defined in paragraph 24.

Description of tests

20. Free uncontrolled flow characteristics were determined by introducing various constant discharges into the model and observing the corresponding upper pool elevation. Sufficient time was allowed for stabilization of the upstream flow conditions. Upper pool elevations were measured at a point corresponding to 350 ft upstream from the spillway. Tailwater elevations were measured at a point corresponding to 750 ft downstream from the end sill.

21. A similar procedure was followed for gate openings ranging from 3 to 9 ft to determine the discharge characteristics of free controlled flow.

22. Submerged flow characteristics for both controlled and uncontrolled flows were determined by introducing several constant discharges into the model. The tailwater for each discharge was varied from an elevation at which no interference with spillway flow was evident to an elevation at which the flow was practically 100 percent submerged. The elevation of the upper pool for each tailwater elevation was recorded.

Presentation and analysis of data

23. Basic data obtained are presented in plots of upper pool elevation versus tailwater elevation for each of the spillway crest designs. The basic calibration data for flow over the type 1 design gates is shown in Plate 9. It should be noted that with flow over the gate there was also some flow

through the side gaps between the ends of the gates and piers and the clearance between the gate and the gate sill with the types 1 and 2 designs, unless stated otherwise. Based on the calibration data for the type 1 design, the US Army Engineer District, Rock Island, designed one 84-ft-wide gate (type 2 design) to pass as much or more discharge as two 60-ft-wide gates. No further data were obtained with the type 1 design. The basic calibration data for the type 2 spillway (also used in the type 3 design) are shown in Plate 10. Free flow data with the type 2 spillway and the gate fully submerged are shown in Plate 11, with the side gaps and gate to sill clearance sealed and unsealed, respectively. Data showing the effect of tailwater elevation on discharge with flow over the gate and a normal upper pool at el 440.0 for the unsealed and sealed conditions are shown in Plates 12 and 13, respectively. Tests conducted on the type 2 spillway indicated that locating the crest further upstream (as in the type 3 design) did not affect the discharge characteristics. Therefore, only data for the type 2 design are included in this report.

24. The following flow conditions and equations were used to satisfy the calibration data of each spillway crest design:

a. Free uncontrolled flow:

$$Q = CLH^{3/2}, \text{ where } C \text{ is a function of } H$$

b. Submerged uncontrolled flow:

$$Q = C_1 LH^{3/2}, \text{ where } C_1 \text{ is a function of } h/H$$

c. Free uncontrolled flow (over the gate):

$$Q = C_c L_c H_c^{3/2}, \text{ where } C_c \text{ is a function of } H_c$$

d. Submerged uncontrolled flow (over the gate):

$$Q = C_{c_1} L_c H_c^{3/2}, \text{ where } C_{c_1} \text{ is a function of } h_c/H_c$$

e. Free controlled flow:

$$Q = C_g L G_o \sqrt{2gH_g}, \text{ where } C_g \text{ is a function of } H_g \text{ and } G_o$$

f. Submerged controlled flow:

$$Q = C_{g_s} L h \sqrt{2g\Delta H}, \text{ where } C_{g_s} \text{ is a function of } H/G_o$$

Symbols used in these equations are defined as follows:

Q = total discharge, cfs

L = net length of spillway weir, ft

H = gross head on spillway weir, ft

h = depth of tailwater above spillway weir, ft

L_c = net length of gate crest, ft

H_c = gross head on gate (flow over gate), ft

h_c = depth of tailwater above gate crest, ft

G_o = gate opening, ft

g = acceleration due to gravity, ft/sec²

H_g = gross head on gate [$H - (G_o/2)$], ft

ΔH = differential between gross head on spillway weir and depth of tailwater referenced to the weir ($H - h$), ft

A definition sketch of each flow regime is shown in Plate 8.

25. Discharge coefficients for free uncontrolled flows with various gross heads on the spillway weir are shown for the type 2 spillway crest design in Plate 14. Discharge coefficients were determined from data obtained in the model with all clearances sealed.

26. The effect of tailwater submergence for uncontrolled flow over the spillway weir was determined by plotting the percent of submergence (h/H) versus a percent reduction in the free flow coefficient (C_1/C) as shown in Plate 15 for the type 2 spillway. As the plot indicates, the C_1/C value approaches unity at an h/H value of about 0.7; thus, free flow conditions exist with values smaller than this.

27. Discharge coefficients for free uncontrolled flow over the gate with various heads on the gate crest are shown in Plate 16 for the type 2 spillway crest design. Discharge coefficients were determined from data obtained in the model with all clearances sealed. These coefficients appear to be somewhat lower than normal free uncontrolled flow coefficients over a spillway crest. However, the configuration of the end of the gate and the manner in which the top of the submerged gate is above the spillway crest cause considerable contraction of flow around the entire perimeter of the gate. This results in a considerable reduction of the effective area of flow and thus the discharge coefficients.

28. The effect of tailwater submergence for uncontrolled flow over the gate is shown by the coefficients in Plate 17. As the plot indicates, the

C_{c1}/C value approaches unity at h_c/H_c equal to about 0.7 and thus free flow conditions exist with values smaller than this.

29. Relations between the free controlled flow discharge coefficient and gross head on the gate for various gate openings with the type 2 spillway crest design are presented in Plate 18. Free controlled flow data are presented in an alternate manner in Plate 19.

30. Submerged controlled flow discharge coefficients versus the ratio of tailwater depth above the spillway weir to gate opening for the type 2 spillway crest design are shown in Plate 20.

31. The data were used to construct plots of discharge versus tailwater elevation for the normal upper pool of 440.0 with flow underneath various gate openings. These plots are shown in Plate 21. Data for the types 2 and 3 design structures are compared in Plate 21. The data in Plate 21 indicated that locating the gate and spillway crest further upstream (as in the type 3 design structure) did not affect the discharge characteristics. The same types of plots with flow over the gate are shown in Plates 12 and 13.

Flow regimes

32. An analysis of the data was made to define the limits of each flow regime and corresponding discharge equation. The results of efforts to distinguish between free and submerged uncontrolled flows over the spillway crest shown in Plate 22 illustrate that, in general, free uncontrolled flow becomes submerged uncontrolled flow for tailwater submergences equal to or greater than 70 percent.

33. The difference between free uncontrolled and submerged uncontrolled flows with flow over the gate can be determined from Plate 23.

34. The plot in Plate 24 indicates that free and submerged controlled flow can be distinguished by the degree of submergence.

35. To define the limits of free controlled and free uncontrolled flows, tests were made with several gate openings G_o and free flow tailwater conditions in which the head H on the spillway weir and the discharge were decreased until the nappe separated from the gate. Observations indicated that free controlled flow became uncontrolled flow when the ratio of H/G_o was equal to or less than 1.2.

36. Similar investigations for submerged flows indicated that submerged controlled flows became submerged uncontrolled flows when the ratio of h/G_o was equal to or less than 1.0 for the ratio $(H - h)/G_o$ less than 0.3

(Plate 25). In distinguishing between those flow regimes (based on observations and calculations), note that for conditions of h/G_o less than 1.0, the flow may be either submerged uncontrolled, free uncontrolled, or free controlled, depending upon the value of $(H - h)/G_o$. If $(H - h)/G_o$ is less than 0.3, the flow is submerged uncontrolled; if $(H - h)/G_o$ is greater than 0.3 but less than 0.6, the flow is free uncontrolled; if $(H - h)/G_o$ is greater than 0.6, the flow is free controlled.

Stilling Basin

Type 1 design

37. The type 1 stilling basin (Plate 3) consisted of a 50-ft-long apron at el 421.6 with two rows of 3-ft-high baffle piers and a 3-ft-high horizontal end sill.

38. Maximum exit velocities were measured about 160 ft downstream of the stilling basin end sill immediately downstream of the wicket gate section with 20 wicket gates passing 15,000 cfs. The upper pool elevation was at el 440.0 and the tailwater elevation was at el 429.0. Velocity distribution immediately downstream of the wickets is shown in Plate 26. After analysis of the flow characteristics with the type 1 design, the Rock Island District designed a single 84-ft-wide gate (type 2 design) that would pass at least as much discharge as the two 60-ft-wide gates (type 1 design); and further testing of the type 1 design was suspended.

Alternate designs

39. The stilling basin was modified to the type 2 basin that consisted of a 43.5-ft-long apron at el 421.6 with one row of 3-ft-high baffles downstream of the tainter gate section and two rows of 3-ft-high baffles downstream of the wicket gate section and 3-ft-high horizontal end sill (Plate 4). Velocities were measured in the 84-ft-wide tainter gate section upstream and downstream of the gate at normal pool (el 440.0) and tailwater el 429.0 with the tainter gate fully opened (Plate 27) and with the tainter gate fully submerged 8 ft (Plate 28). Maximum bottom velocities in the basin ranged from 3 to 20 fps with the tainter gate fully opened and 3 to 26 fps with the tainter gate fully submerged. Entrance velocities varied from 2 to 6 fps with the tainter gate fully opened and 2 to 4 fps with the tainter gate fully submerged. Exit velocities ranged from 4 to 15 fps with the tainter gate fully

opened and 2 to 10 fps with the tainter gate fully submerged.

40. The design was modified to the type 3 design basin that consisted of a 131.25-ft-long apron at el 421.6 that included one row of 3-ft-high baffles followed by the 3-ft-high existing wicket sill and two more rows of 3-ft-high baffles and a 3-ft-high horizontal end sill downstream of the 84-ft-wide tainter gate (Plate 5). The existing wicket section stilling basin remained unchanged. Velocities were measured in the 84-ft-wide tainter gate section upstream and downstream of the gate at normal pool (el 440.0) and tailwater el 429.0 with the tainter gate fully opened (Plate 29) and with the tainter gate fully submerged 8 ft (Plate 30). Maximum bottom velocities in the basin ranged from 3 to 20 fps with the tainter gate fully opened and 1 to 25 fps with the tainter gate fully submerged. Entrance velocities varied from 3 to 6 fps with the tainter gate fully opened and 3 to 4 fps with the tainter gate fully submerged. Exit velocities ranged from 4 to 11 fps with the tainter gate fully opened and 4 to 9 fps with the tainter gate fully submerged. Because of the greater energy dissipation in the basin (as evidenced by lower velocities), the type 3 design was recommended for prototype construction and all further testing was conducted with the type 3 design only.

41. As requested by the Rock Island District, the depth of flow entering the stilling basin d_1 and the tailwater depth at the end sill d_2 were measured for minimum tailwater depths attainable in the model for various gate openings and discharges. The depth of flow entering the stilling basin d_1 and the depth of tailwater d_2 were measured as indicated in Figure 6. The

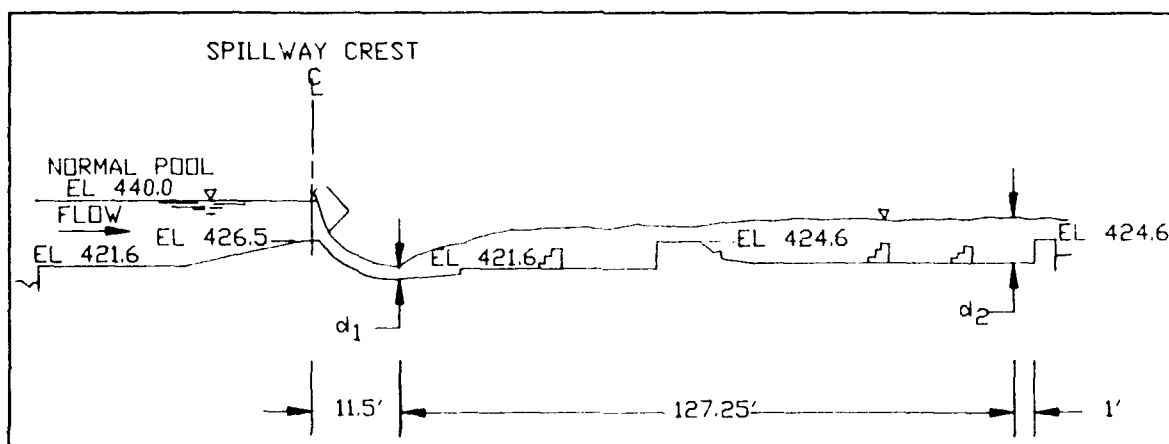

Figure 6. Location of d_1 and d_2 measurements

d_1 depth was measured 11.5 ft downstream of the spillway crest center line, and the d_2 depth was measured 138.75 ft downstream of the spillway crest center line, 1 ft upstream of the end sill. These values are tabulated in Table 1 for gate openings of 3, 5, and 7 ft and fully open and 3, 5 and 7 ft of submergence and full submergence of 8 ft.

Riprap Requirements

Upstream

42. Details of the riprap protection in the approach areas, upstream of the wicket gate section and tainter gate section, along the lock wall and around the pier bases as tested in the model are shown in Plate 31. The approach area and the area along the lock wall were covered with protective stone simulating prototype stone with an average weight of 400 lb. The riprap extended 40 ft out from the right pier, 40 ft upstream of the structure, and 18 ft out from the lock wall. Riprap gradation curves for all riprap used in testing are plotted in Plates 32-34. Twenty wickets were operated with a normal upper pool (el 440) and a minimum tailwater (el 429). The protection upstream of the wicket gates remained stable for discharges up to and including 9,600 cfs which was the maximum discharge passed by 20 wickets for these conditions. Tests were conducted with the tainter gate fully open with a normal upper pool (el 440.0) and a minimum tailwater (429.0) in accordance with Engineer Technical Letter (ETL) 1110-2-290.* The riprap protection upstream of the tainter gate remained stable for discharges up to and including 12,250 cfs, the maximum discharge with these conditions.

43. After the model study was completed, the Rock Island District decided to delete the scour protection developed in the model upstream of the wicket gates based on the fact that the existing riverbed and protection have remained stable since 1972. With the installation of the new submersible tainter gate, the scour conditions upstream of the wicket gates are less severe than preprototype construction conditions. The high-head, lower flows, which cause the greatest scour, are being passed through the tainter gate rather than through the wickets as the dam was formerly operated. Because the

* Headquarters, US Army Corps of Engineers. 1983 (31 Oct). "Low Head Navigation Dam Stilling Basin Design," ETL 1110-2-290, US Government Printing Office, Washington, DC.

scour potential upstream of the wickets was not increased by the proposed regulation of the dam and existing prototype upstream riprap is larger than the model indicated was needed, the Rock Island District felt that additional scour protection upstream of the wicket section was not justified. Upstream protection of the lock wall and tainter gate section was recommended by the US Army Engineer Waterways Experiment Station (WES). The proposed upstream protection plan recommended to the Rock Island District is shown in Plate 35.

44. The proposed cofferdam design was installed in the model to determine riprap requirements for protection of the dam during construction. The riprap was placed as indicated in Plate 36. A 36-in.-thick blanket of protective stone with an average weight of 400 lb placed in the model remained stable for all discharges through 20 wickets.

Downstream

45. Twenty wickets were operated with a normal upper pool (el 440.0) and a minimum tailwater (el 429.0). The scour hole that formed in the model after 26 hr of continuous operation at this condition was lined with riprap. The riprap protection was placed to completely cover the extent of scour as shown in Plate 31. A 42-in.-thick blanket of uniformly graded protective stone with an average weight of 1,750 lb followed by a 36-in.-thick blanket of uniformly graded protective stone with an average weight of 780 lb was placed downstream of the wicket gate section in the model. Tests were conducted with 20 wickets operating with a normal upper pool (el 440.0) and a minimum tailwater (el 429.0). The flow through the wickets was concentrated on the water surface downstream of the wicket gate end sill (Photo 4), and the downstream riprap protection remained stable for discharges up to and including 9,600 cfs. The extent of riprap protection was reduced in the model as shown in Plate 37. The riprap protection downstream of the wickets consisted of a 110-ft-long section of 42-in.-thick riprap followed by 100 ft of 36-in.-thick riprap. Tests were again conducted with 20 wickets operating, a normal upper pool (el 440.0), and minimum tailwater (el 429.0). The protection downstream of the wickets remained stable for discharges up to and including 9,600 cfs.

46. After the model study was completed, the Rock Island District also decided to delete the scour protection developed in the model downstream of the wicket gate section based on the 50-year service record of Peoria Dam. The existing riverbed has remained stable for 50 years. With the installation of the new submersible tainter gate, the scour conditions downstream of the

wicket section will be less severe than at present as discussed in paragraph 43.

47. Riprap protection downstream of the tainter gate section was placed on a level bed to determine protection requirements for pre-scour conditions as shown in Plate 31. A 42-in.-thick blanket of uniformly graded protective stone with an average weight of 1,750 lb followed by a 36-in.-thick blanket of uniformly graded protective stone with an average weight of 780 lb was placed downstream of the tainter gate section. The uniformly graded protective stone was also placed in a 36-in.-thick blanket along the lock wall as shown. Tests were conducted with the tainter gate fully open with a normal upper pool (el 440.0) and a minimum tailwater (el 429.0) in accordance with ETL 1110-2-290.* The riprap protection remained stable for discharges up to and including 12,250 cfs.

48. Prior to placing riprap, the model submersible tainter gate was fully opened with a normal upper pool (el 440.0) and a minimum tailwater (el 429.0). A scour hole developed while this condition was run continuously for 26 hr. Riprap protection was placed downstream of the tainter gate section and along the lock wall in the model as shown in Plate 37. A 110-ft-long 42-in.-thick blanket of protective stone with an average weight of 1,750 lb followed by a 100-ft-long 36-in.-thick blanket of protective stone with an average weight of 400 lb was placed downstream of the tainter gate section and along the lock wall as shown. Tests were conducted with a normal upper pool (el 440.0) and a minimum tailwater (el 429.0) and the gate fully open. The downstream protection remained stable for discharges up to and including 12,250 cfs.

49. Because of the difficulty of controlling underwater placement of riprap at the Peoria Dam and the added economics of requiring quarries to produce small quantities of several gradations, the Rock Island District proposed using a single class of stone, class "E" (with an average weight of 1,750 lb), in a revised scour protection plan. As a secondary line of protection, sheet piling along the lock wall was added that will remain cantilevered from the sub-bed material if the scour protection fails. The revised protection plan proposed by the Rock Island District is shown in Plates 38 and 39. The WES-recommended scour protection plan (Plate 37) incorporated various

* Op. cit.

gradations of riprap placed in very well-defined areas. An increase in stone size and riprap layer thickness (as proposed by the Rock Island District) should increase the degree of protection. The class "E" riprap had a d_{50} of 32 in. (the largest that was model tested). Farther downstream, stone with a smaller d_{50} provided adequate protection in the model. Therefore the use of the larger (class "E") stone at thicknesses equal to or greater than those recommended by WES (as in the Rock Island District-proposed revised protection plan) was found acceptable to WES.

Gate Cable Loads and Vibrations

50. Instrumentation was not installed on the model until the type 3 design was installed in the model; therefore hydraulic forces were measured with the type 3 design only. The type 3 design for the spillway and submersible tainter gate has been described in paragraphs 11 and 12; general dimensions are shown in Plate 5.

51. Tests were conducted to assure that the natural frequency of the model cables was in the range of the natural frequency of the prototype cables. The model cable natural frequency (converted to prototype) ranged from 2.68 (gate partially in the water) to 4.70 Hz (gate dry). The prototype cable natural frequency was estimated by the Rock Island District to be 3.32 Hz.

52. Forces induced in the gate lifting cables by flow under and over the subject gate were measured with a normal upper pool (el 440.0) in combination with various tailwater elevations. The test procedure is described in paragraph 16. A profile sketch and definitions of terms are presented in Plate 40. A sample oscillograph record and sample calculation are presented in Plate 41. Test results for flow over and under the gate are tabulated in Tables 2 and 3, respectively.

53. The model test results indicated that the gate cables will be subjected to loads occurring at a random frequency during normal operations with flow under small gate openings due to contact of the gate with flow. The magnitude of these vibrations, however, is small (less than 2 percent) compared to the gate's 126-ton dry weight. Loads began to occur at a random frequency for a gate submergence of 8 ft (fully submerged). With flow over the gate, the likelihood of forces acting on the cables at a periodic

frequency was indicated for submergences of 1 to 7 ft and expected headwaters and tailwaters as shown in Table 2. The natural frequency of the prototype lifting cables (estimated by the Rock Island District to be 3.32 Hz) falls within the range of the periodic frequency of the flow-induced forces (1.8-3.6 Hz) measured in the model. In a similar model study of the Marseilles Lock and Dam submersible tainter gate, the incidence of periodic vibrations was attributed to the gap at the sides of the gate.* A 60-ft-wide by 16-ft-high gate was tested using several combinations of gate to sill clearances and gate to pier clearances. Decreasing the gate to pier clearance eliminated the periodic gate vibrations, while increasing the clearances resulted in more severe periodic vibrations.

54. Because of likelihood of the occurrence of random vibrations during normal operations of the Marseilles gate with flow over and under the Marseilles gates, a friction shoe that could be installed on each side of the gate between the gate and pier was tested in the model. Although tests with the friction shoe indicated essentially no occurrence of vibrations, there was some doubt that these results were anything but qualitative because the friction in the model supplied by the friction shoe cannot be directly scaled to simulate prototype friction. The value of a friction shoe is that it provides a factor of safety in the event that vibrations do occur. The Rock Island District, however, opted not to include the friction shoe in the construction contract for either the Marseilles or Peoria submersible tainter gates with the following rationale. The total amplitude Δ_p of the highest load fluctuation measured in the model was considerably lower than the total side seal and trunnion friction. The side seal and trunnion friction were not modeled in the Peoria model.

55. The tendency and frequency of vibrations increased at the small gate submergence (1-3 ft). The smaller gate submergences produced unstable conditions because of the almost equal amount of flow under and over the gate. As the tailwater increased, the flow under the gate (between the gate and sill) decreased and the magnitude and frequency of vibrations decreased.

56. As requested by the Rock Island District, forces on the cables were measured with various flood flows and the gate submerged 8 ft below the normal

* Deborah R. Cooper. 1989. "Submersible-Type Tainter Gate for Spillway, Marseilles Lock and Dam; Hydraulic Model Investigation," Technical Report HL-89-1, US Army Engineer Waterways Experiment Station, Vicksburg, MS.

upper pool el of 440.0 (fully submerged). The downstream skin plate is designed for a head of 12 ft, and this test was intended to confirm the District's expectations that the gate would vibrate with submergences greater than 12 ft. Normal operating procedure is to raise the gate out of the flow during floods, and the District has no intention of leaving the gate submerged when the pool rises above el 440.0. However, vibrations are alleged to have occurred with similar Mississippi River submersible tainter gates that were left submerged during a flood in the early days of that facility's operation. In the model at pool el 444.0 and above (submergences 12 ft or greater), the gate cables experienced severe vibrations as indicated in Table 4. The gate alternated between bouncing and settling. The gate was placed 2 ft in the water at pool el 441 with flow under the gate. The gate cables did not experience any vibrations with this condition (Table 5).

PART IV: CONCLUSIONS

57. Results of tests to determine discharge characteristics of the Peoria Dam with the type 2 spillway crest indicated six possible flow conditions that can be satisfied by the equations discussed in paragraph 24. These conditions are as follows:

- a. Free uncontrolled flow over the spillway as shown in Plate 14.
- b. Submerged uncontrolled flow over the spillway as shown in Plate 15.
- c. Free uncontrolled flow over the gate as shown in Plate 16.
- d. Submerged uncontrolled flow over the gate as shown in Plate 17.
- e. Free controlled flow as shown in Plate 18.
- f. Submerged controlled flow as shown in Plate 20.

58. Stilling basin performance tests and velocities measured downstream of the basin indicated that the type 3 design structure (with a longer basin) provided more energy dissipation.

59. A riprap protection plan upstream and downstream of the wicket gate section was developed in the model. The service record of Peoria Dam indicates that the riverbed and upstream protection have remained stable since 1972. Because the scour potential upstream of the wickets was not increased by the proposed regulation of the dam, the Rock Island District felt that additional scour protection upstream of the wickets was not justified. The existing riverbed downstream of the wickets has remained stable for 50 years. With the installation of the submersible tainter gate, the scour conditions downstream of the wicket section are less severe than with preprototype conditions. Because the scour potential downstream of the wickets was not increased by the proposed regulation of the dam, the Rock Island District felt that additional scour protection downstream of the wicket gate section was not justified.

60. The riprap protection plan developed in the model upstream of the tainter gate section consisted of a 36-in.-thick blanket of protective stone with an average weight of 400 lb. The blanket extended 40 ft out from the right pier and 40 ft upstream of the structure and for 18 ft out from the lock wall. The riprap protection plan developed in the model downstream of the tainter gate section consisted of a 42-in.-thick blanket of uniformly graded

protective stone with an average weight of 1,750 lb followed by a 36-in.-thick blanket of protective stone with an average weight of 400 lb. The riprap was placed for 210 ft downstream of the tainter gate section and along the entire length of the lock wall. Tests conducted with a normal upper pool (el 440.0), minimum tailwater (el 429.0), and the gate fully open indicated that the riprap remained stable. Because of the difficulty in controlling underwater placement of riprap at Peoria Dam and the added economics of requiring quarries to produce small quantities of several gradations, the Rock Island District proposed using the 42-in.-thick blanket of stone with an average weight of 1,750 lb for the full extent in a revised scour protection plan. As a secondary line of protection, sheet piling along the lock wall was added that will remain cantilevered from the sub-bed material if the scour protection fails. The protective plan developed by WES used smaller stone at a smaller blanket thickness. Therefore, the use of the larger stone at thicknesses equal to or greater than those recommended by WES (as in the Rock Island District revised protection plan) was found acceptable to WES.

61. Testing of the type 3 design structure (a 2.0-ft-broad horizontal sill preceded with a 1V on 9H sloping face and a 131.35-ft-long stilling basin) indicated the gate cables to be subject to load fluctuations occurring at a random frequency during normal operations with flow under small gate openings due to contact between the gate and the water surface. The magnitude of these vibrations, however, is less than 2 percent of the gate's total 126-ton dry weight. The prototype cables should not detect these load fluctuations because these vibrating forces are less than the combination of the prototype trunnion and side seal frictions. The natural frequency of the prototype lifting cables (estimated by the Rock Island District to be 3.32 Hz) falls within the range of the periodic frequency of the flow-induced forces (1.8-3.6 Hz) measured in the model. A dogging device such as the friction shoe recommended for the Marseilles Lock and Dam* is recommended for a factor of safety. Based on the gate's performance, the type 3 design structure with friction shoe is recommended for prototype construction. The prototype gate is already constructed without a friction shoe. The flows on the Illinois River have been such that the Rock Island District has not tested the gate throughout its full operating range. The District will continue to monitor

* Cooper, op. cit.

the gate for any indication of vibration. However, the District does not anticipate that the friction shoe will be necessary as was the case at Marseilles Dam whose gates have been tested throughout their operating range. The type 3 design was built (instead of types 1 or 2) because of dewatering considerations for construction.

62. Tests with higher than normal upper pool elevation (el 444.0-446.0) confirmed the Peck Island District's expectations that the gate in the fully submerged position would be subject to very severe and periodic bouncing and should not be left submerged at a higher than normal upper pool for any tailwater condition. Also as the tailwater elevation increases, the gate should be raised out of the water to avoid the gate alternately floating and bouncing.

Table 1
d₁ and d₂ Measurements

<u>G_o</u> <u>ft</u>	<u>Q</u> <u>cfs</u>	<u>d₁</u> <u>ft</u>	<u>d₂</u> <u>ft</u>	<u>Gate</u> <u>Submergence</u> <u>ft</u>	<u>Q</u> <u>cfs</u>	<u>d₁</u> <u>ft</u>	<u>d₂</u> <u>ft</u>
3	2,000	2.82	6.66	3	2,000	2.40	5.10
5	4,000	4.12	7.02	5	3,000	2.68	6.60
	5,000	4.02	7.36		4,000	2.74	7.08
	6,000	4.00	7.62		5,000	3.10	7.10
7	6,000	4.80	7.32	7	4,000	2.74	6.54
	7,000	4.72	8.48		5,000	3.20	7.04
	8,000	4.62	8.68		6,000	3.40	7.40
Open Fully	4,000	2.74	6.72	8	7,000	3.98	8.52
	5,000	3.20	7.36		8,000	4.48	8.64
	6,000	3.54	7.56		4,000	2.90	7.18
	7,000	4.26	8.00		5,000	3.12	7.28
	8,000	4.80	8.50	6,000	3.86	7.62	
	9,000	5.40	8.64	7,000	4.26	8.25	
	10,000	5.90	8.98	7,500	4.56	8.46	
	11,000	6.50	9.38	8,000	4.88	8.60	
	12,000	6.86	9.80				
	13,000	7.44	9.96				

Table 2

Hoist Cable Loads

Type 3 Design Structure

Flow Over Gate

HW EL 440.0

Gate Submergence ft	TW EL	F ₁ lb	F ₂ lb	F ₃ lb	F ₄ lb	F ₅ max lb	F ₅ min lb	f Hz	A p lb
1	429	175,200	5,700	169,500	230,100	60,600	59,100	3.58	1,500
	431	175,200	8,500	166,700	226,500	59,800	59,800	0	0
3	429	161,600	8,500	153,100	244,300	91,200	88,200	3.13	3,000
	433	161,600	15,200	146,400	240,400	94,000	91,000	2.91	3,000
	435	161,600	17,100	144,500	224,500	80,000	77,000	2.24	3,000
	437	161,600	19,000	142,600	184,800	42,200	42,200	0	0
5	429	150,600	11,400	139,200	218,500	79,300	77,300	2.68	8,000
	433	150,600	17,100	133,500	212,600	79,100	77,100	2.46	6,000
	435	150,600	19,000	131,600	164,900	33,300	32,300	1.78	4,000
	437	150,600	19,000	131,600	121,200	-10,400	-10,400	Random	--*
7	429	144,200	14,200	130,000	223,400	93,400	91,400	2.01	2,000
	433	144,200	19,000	125,200	212,600	87,400	85,400	2.01	2,000
	435	144,200	19,000	125,200	156,900	31,700	30,700	1.78	1,000
	437	144,200	19,000	125,200	113,300	-11,900	-11,900	Random	--*
8	429	138,900	16,100	122,800	200,600	77,800	77,800	Random	500
	433	138,900	19,000	119,900	170,800	50,900	50,900	Random	500
	435	138,900	19,000	119,900	115,200	-4,700	-4,700	Random	--*
	437	138,900	19,000	119,900	67,500	-52,400	-52,400	Random	--*

* Low magnitude.

Table 3
Hoist Cable Loads
Type 3 Design Structure
Flow Under Gate
HW EL 440.0

<u>G_o</u> <u>ft</u>	<u>TW</u> <u>EL</u>	<u>F₁</u> <u>lb</u>	<u>F₂</u> <u>lb</u>	<u>F₃</u> <u>lb</u>	<u>F₄</u> <u>lb</u>	<u>F₅</u> <u>max</u> <u>lb</u>	<u>F₅</u> <u>min</u> <u>lb</u>	<u>f</u> <u>Hz</u>	<u>Δ_p</u> <u>lb</u>
1	429	189,700	1,600	188,100	198,700	10,600	10,600	0	0
	432	189,700	5,200	184,500	190,700	6,200	6,200	0	0
	433	189,700	6,300	183,400	188,700	5,300	5,300	0	0
2	429	191,800	800	191,000	212,600	21,600	21,600	0	0
	431	191,800	2,100	189,700	204,700	15,000	15,000	Random	2,000
	433	191,800	5,200	186,600	194,800	8,200	8,200	0	0
	434	191,800	6,300	185,500	186,700	1,200	1,200	0	0
4	431	201,400	800	200,600	210,700	10,100	10,100	0	0
	433	201,400	2,100	199,300	210,600	11,300	11,300	Random	2,000
	435	201,400	5,200	196,200	206,600	10,400	10,400	Random	4,000
	437	201,400	7,100	194,300	196,700	2,400	2,400	Random	2,000
6	433	201,400	500	200,900	212,600	11,700	11,700	0	0
	435	201,400	2,600	198,800	210,600	11,800	11,800	0	0
	437	201,400	4,700	196,700	204,600	7,900	7,900	Random	2,000
	439	201,400	7,100	194,300	194,700	400	400	0	0
8	433	206,400	0	206,400	226,500	20,100	20,100	0	0
	435	206,400	500	205,900	226,500	20,600	20,600	0	0
	437	206,400	2,600	203,800	224,500	20,700	20,700	0	0
	439	206,400	4,700	201,700	214,600	12,900	12,900	0	0
10	433	207,500	0	207,500	226,500	19,000	19,000	0	0
	435	207,500	0	207,500	226,500	19,000	19,000	0	0
	437	207,500	500	207,000	224,500	17,500	17,500	0	0
	439	207,500	2,600	204,900	222,500	17,600	17,600	0	0

Table 4
Hoist Cable Loads
Type 3 Design Structure
Gate Fully Submerged

<u>HW</u> <u>EL</u>	<u>TW</u> <u>EL</u>	F_4 <u>lb</u>	<u>f</u> <u>Hz</u>	Δ_p <u>lb</u>
444	432	111,300	2.4	20,000
444	434.5	69,500	2.3	15,000
445	437	31,800	2.0	10,000
445	440	Fluttering	-	-
446	443	524,000	Bounced then settled	
446	445	Fluttering	-	-

Table 5
Hoist Cable Loads
Type 3 Design Structure
Flow Under Gate
 G_o 12 ft

<u>HW</u> <u>EL</u>	<u>TW</u> <u>EL</u>	F_4 <u>lb</u>	<u>f</u> <u>Hz</u>	Δ_p <u>lb</u>
441	428	204,600	-	-
	434	202,500	-	-
	439	202,500	-	-

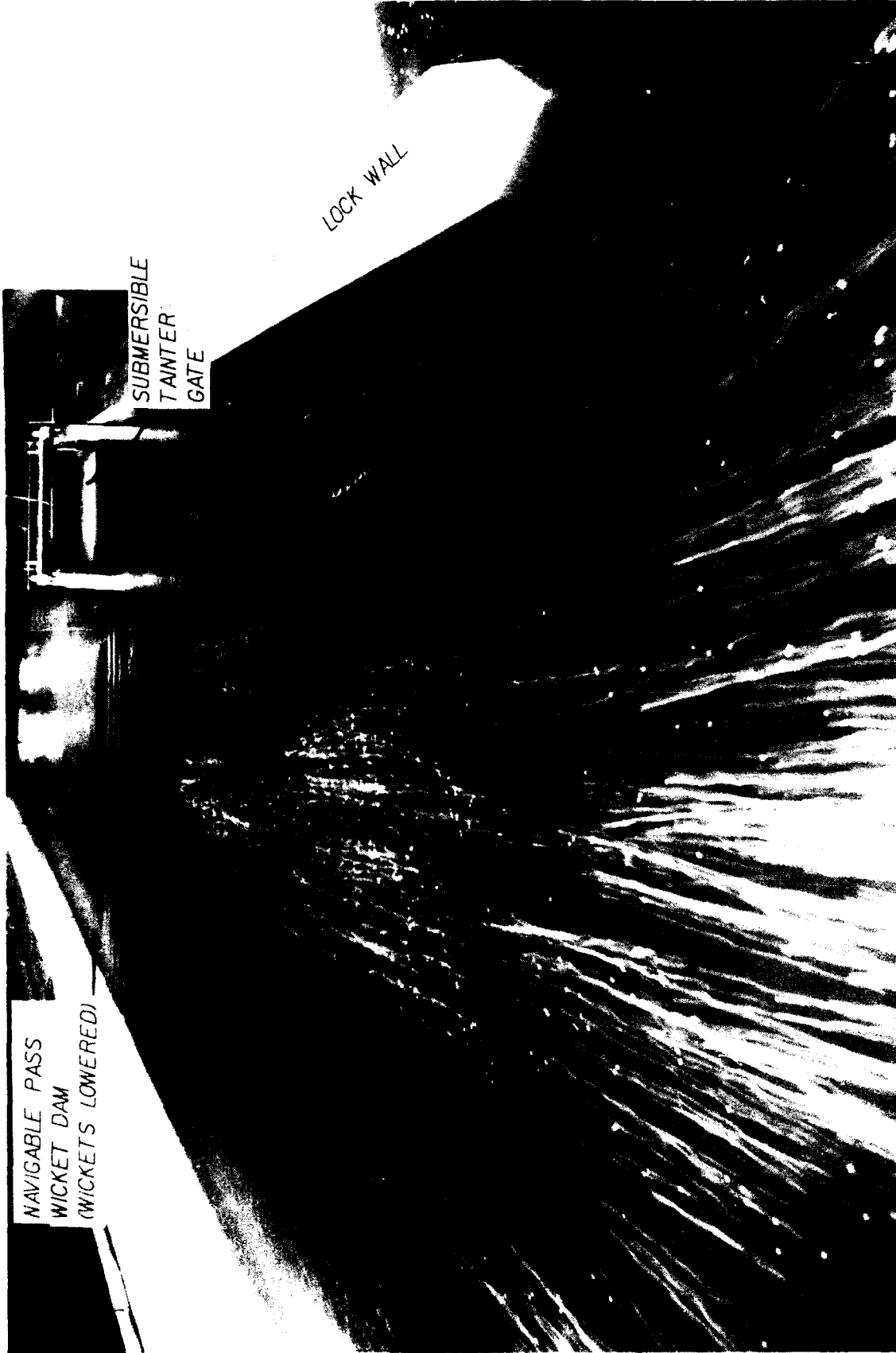

Photo 1. Navigable Pass with all wickets lowered; headwater el 440.0; tailwater el 429.0



Photo 2. Flow under model gate; gate fully open; type 3 design;
headwater el 440.0; tailwater el 429.0

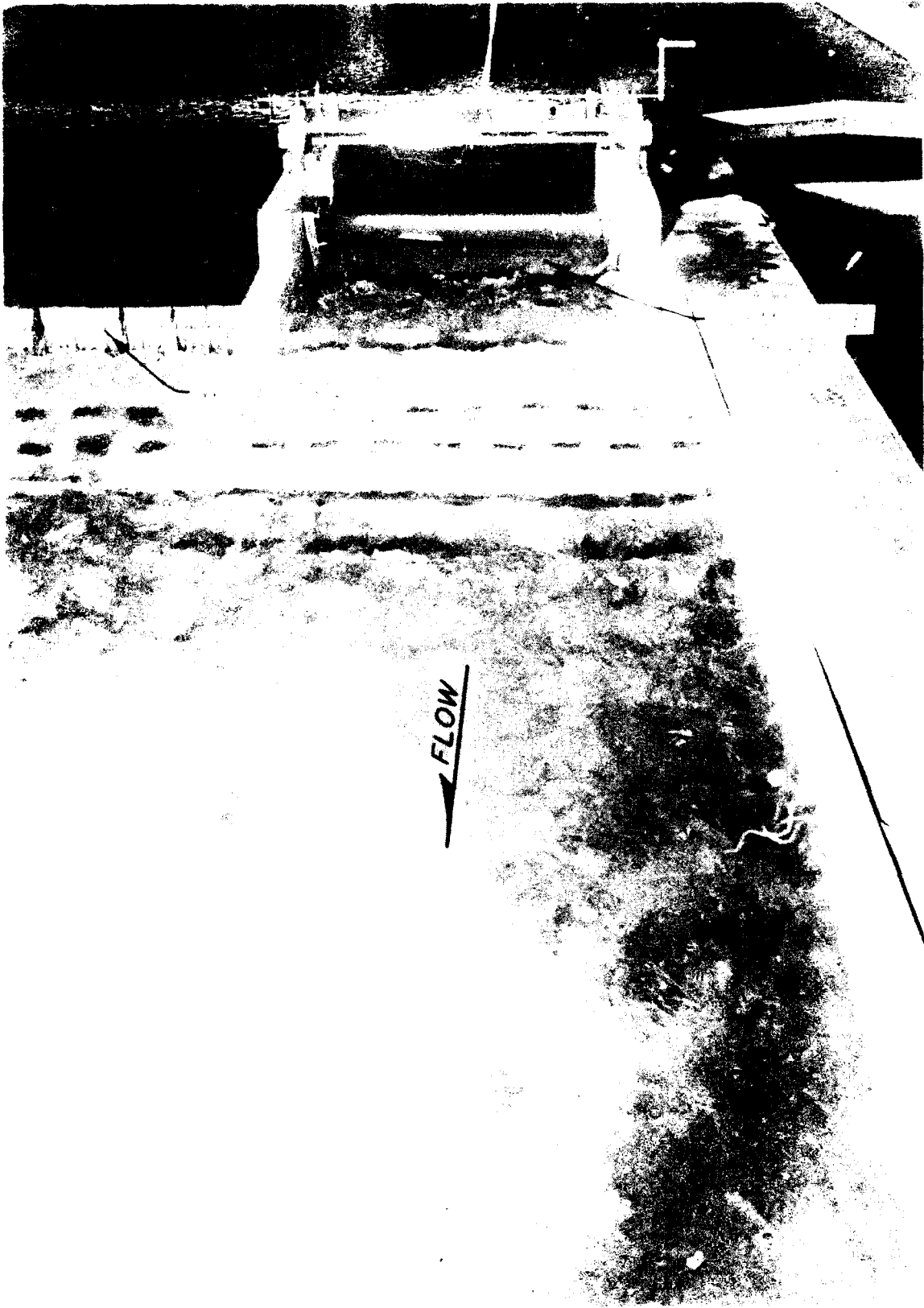
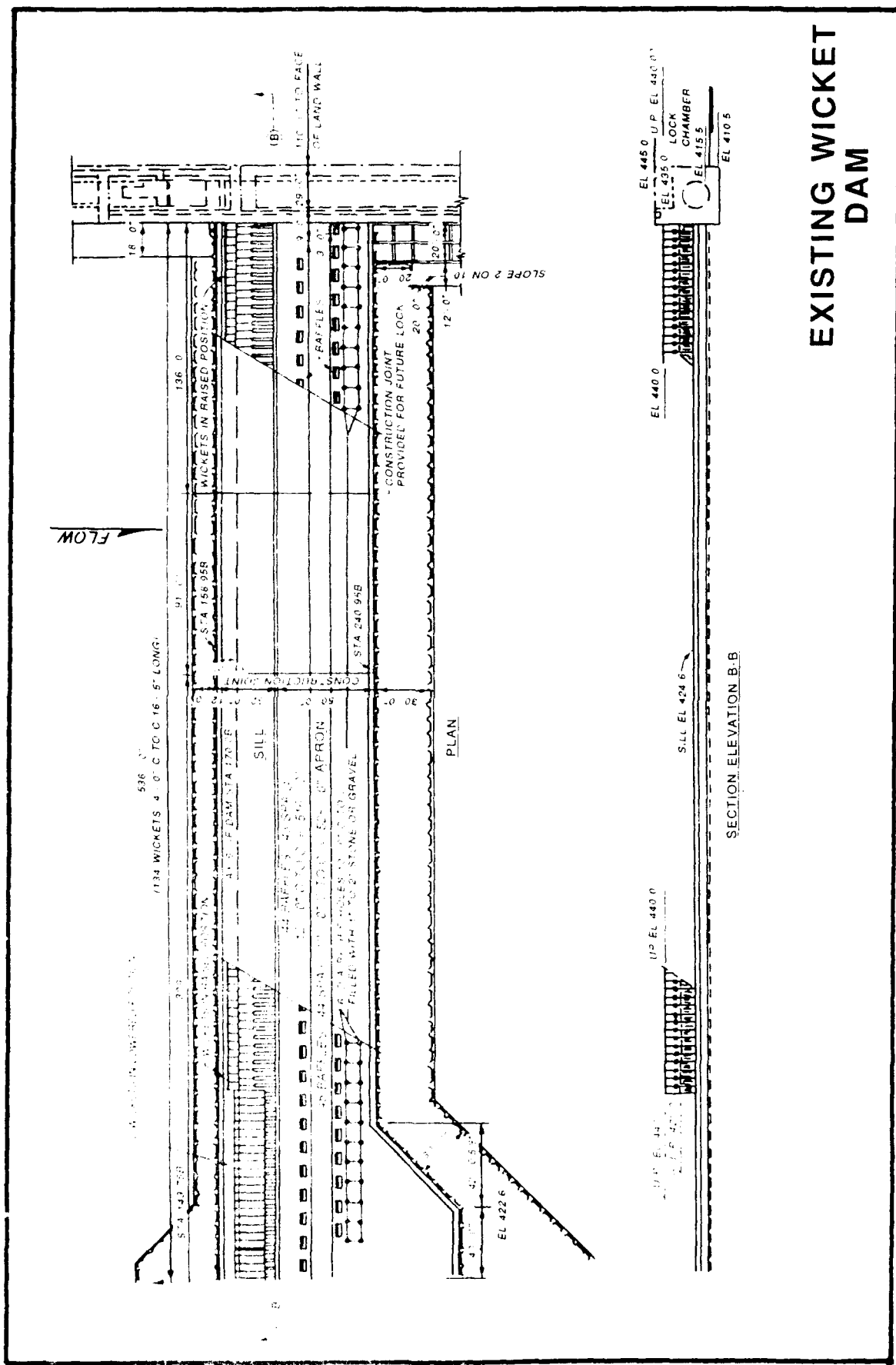

Figure 1. Flow over a spillway gate fully submerged; type 4 design.
Reservoir water depth 1.2 m; tailwater 0.2 m.



Photo 4. Tainter gate fully submerged with 20 wickets operating; type 3 design; headwater el 440.0; tailwater el 429.0



EXISTING WICKET DAM

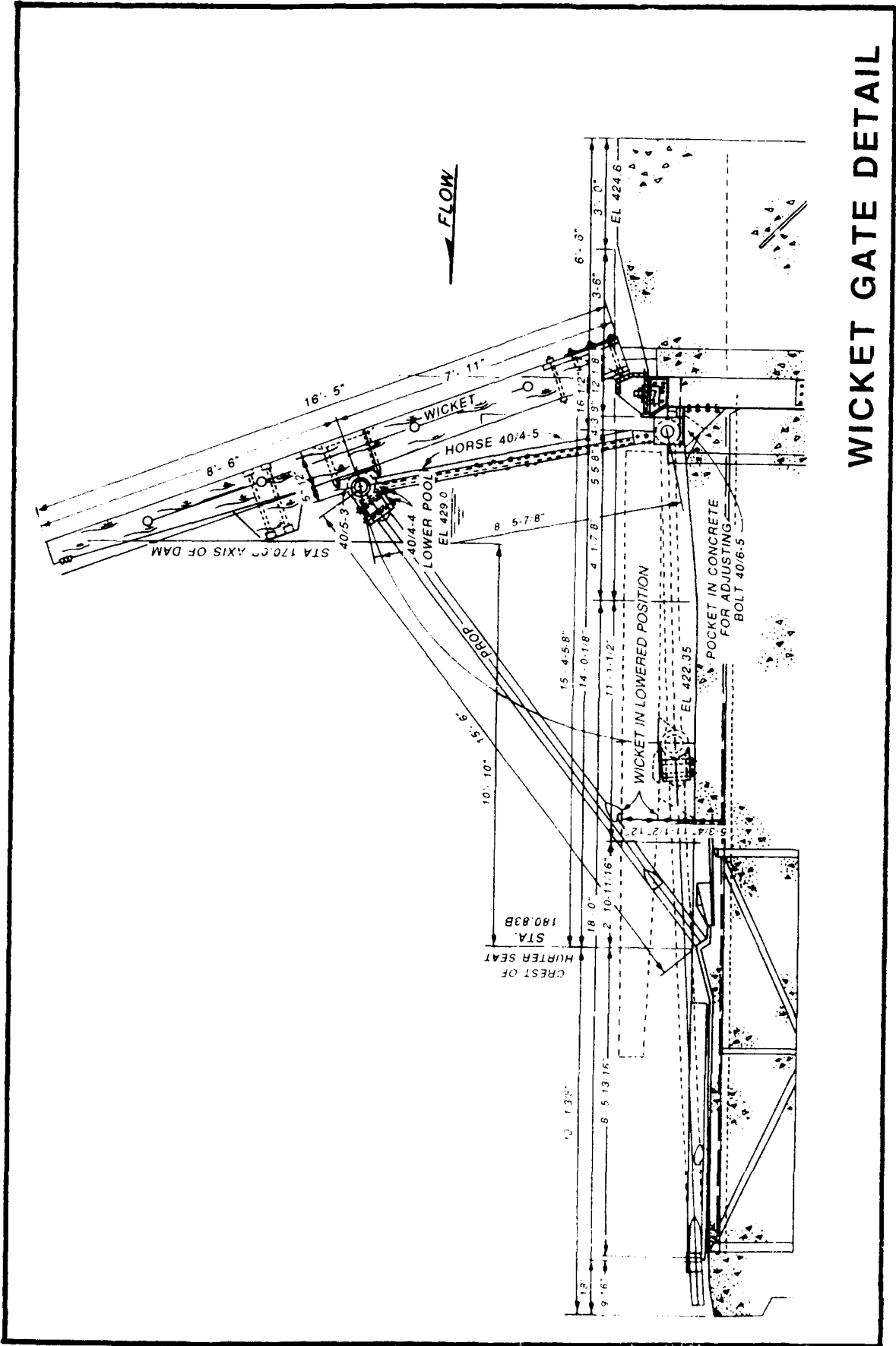

WICKET GATE DETAIL

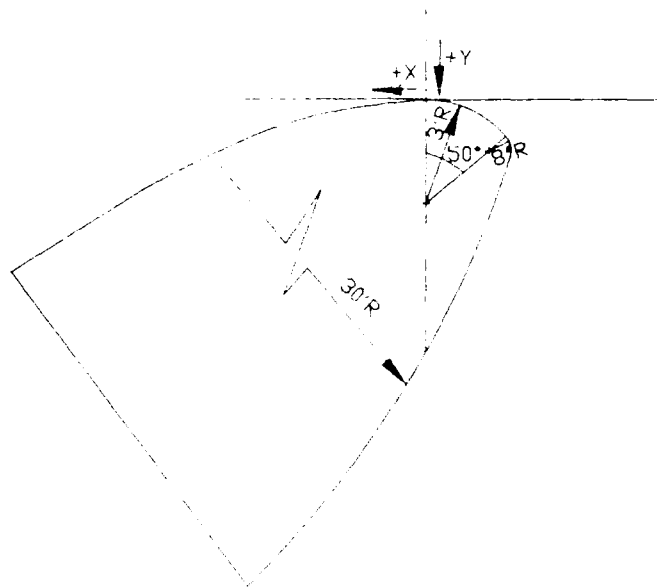

GATE DETAIL

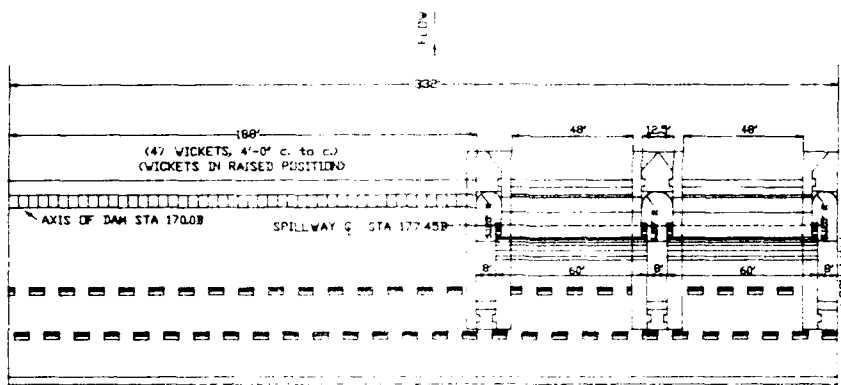

PLAN VIEW

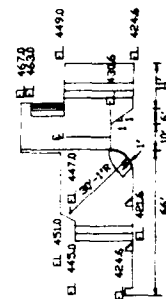

PROFILE VIEW
CENTER PIER

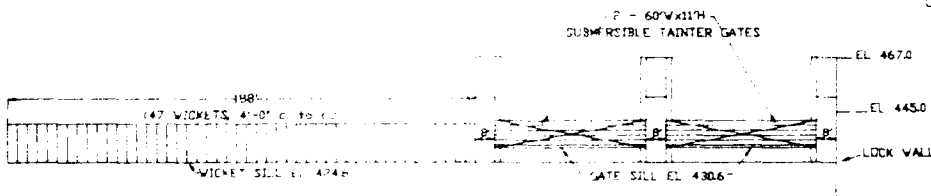

DOWNSTREAM ELEVATION (1/8" = 1'-0")

TYPE 1 (ORIGINAL) DESIGN STRUCTURE
GATE AND PIER DETAIL

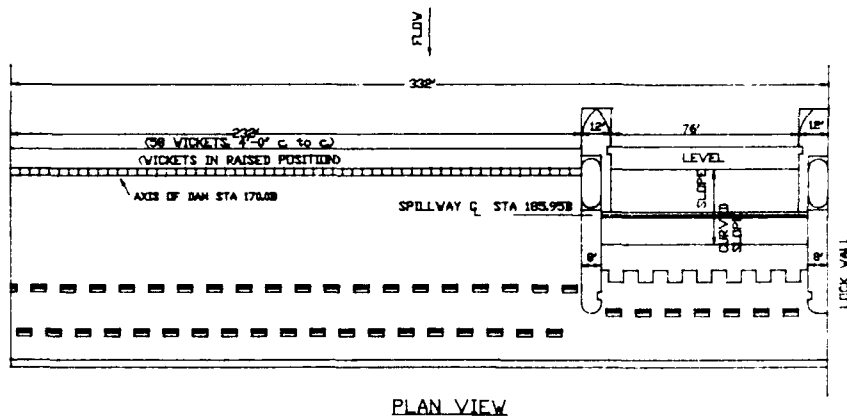
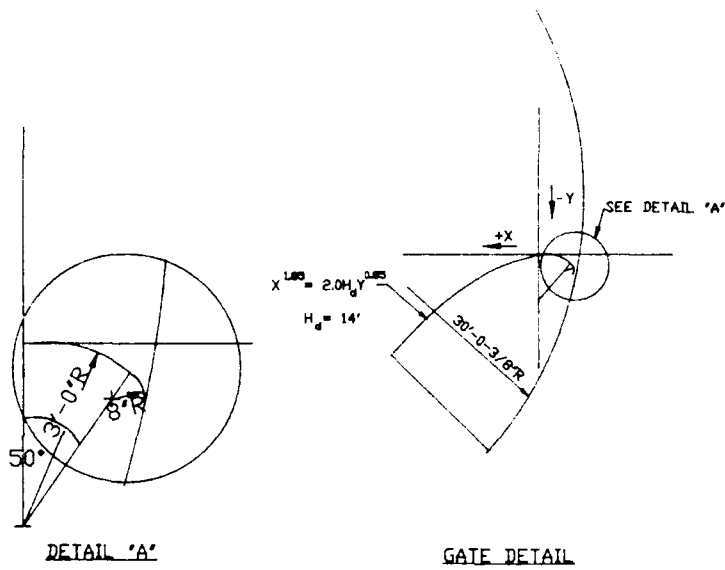

PLAN VIEW

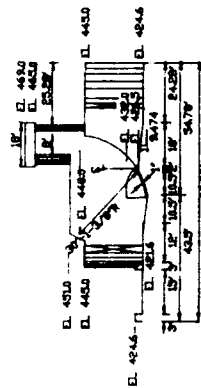

PROFILE VIEW

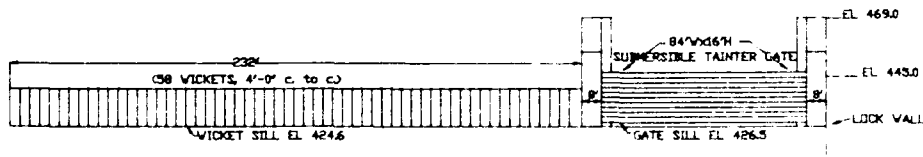

DOWNSTREAM ELEVATION VIEW

TYPE 2 DESIGN STRUCTURE
GATE AND PIER DETAIL

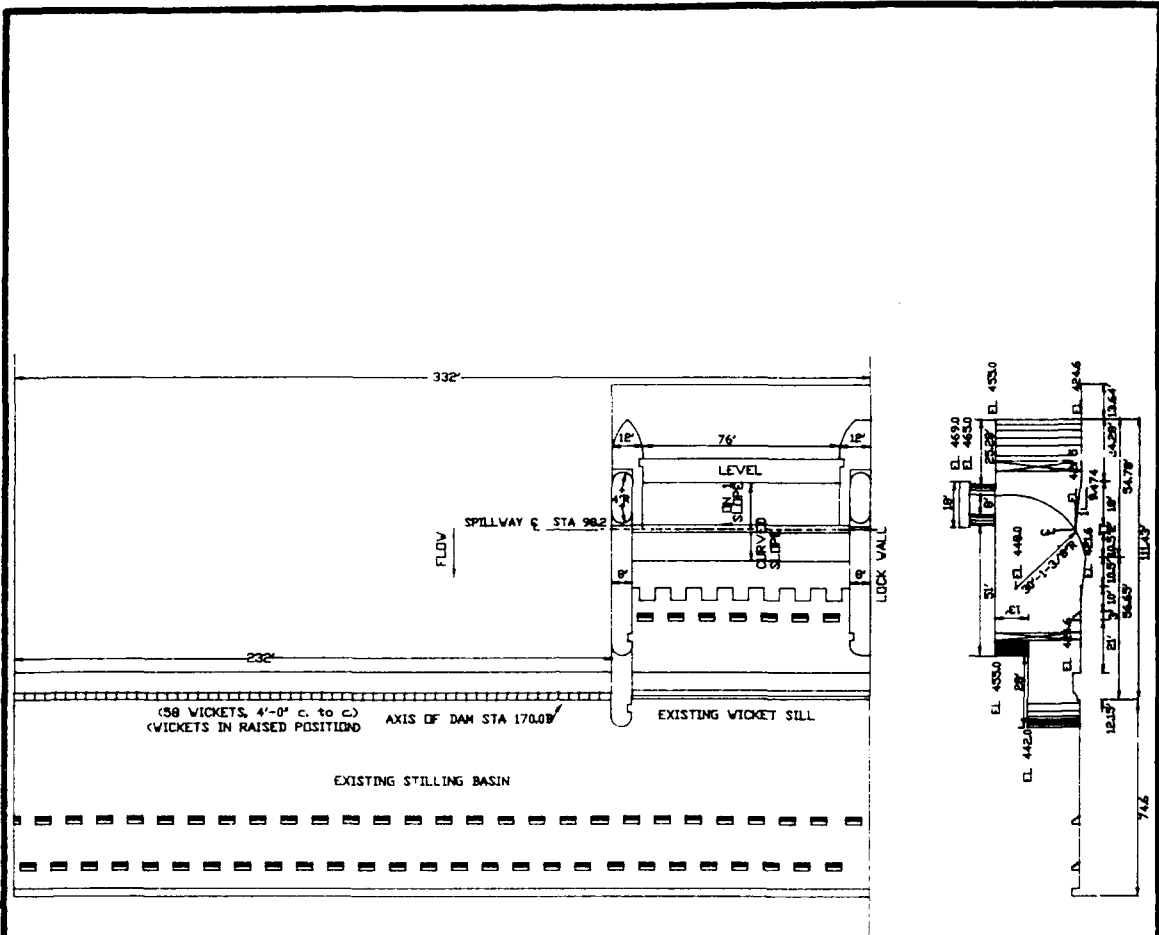

PLAN VIEW

PROFILE VIEW

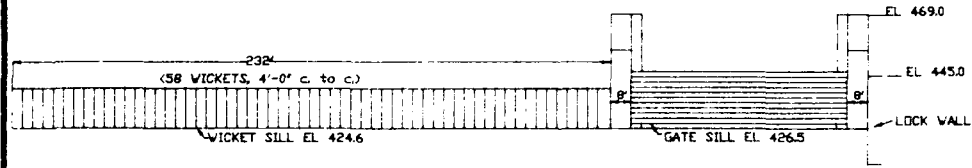

DOWNSTREAM ELEVATION VIEW

NOTE: SEE PLATE 4 FOR GATE DETAIL

**TYPE 3 DESIGN STRUCTURE
DETAIL**

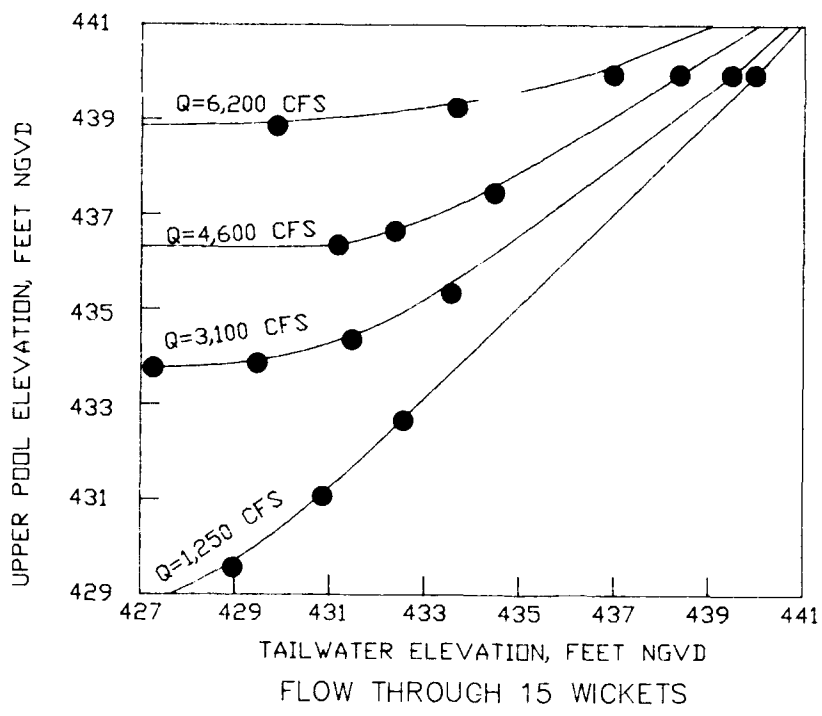
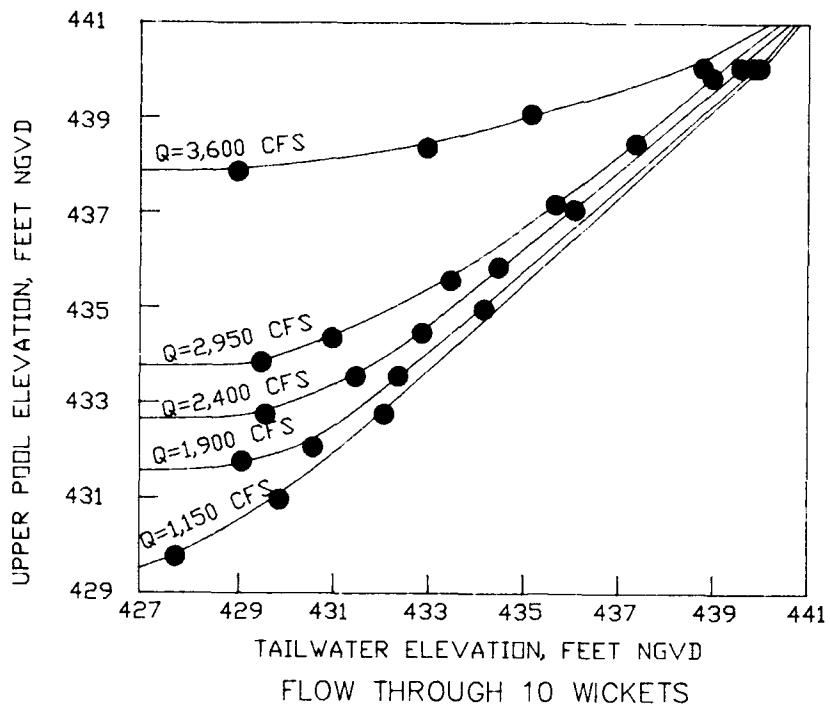

BASIC CALIBRATION DATA
WICKET SILL EL 424.6

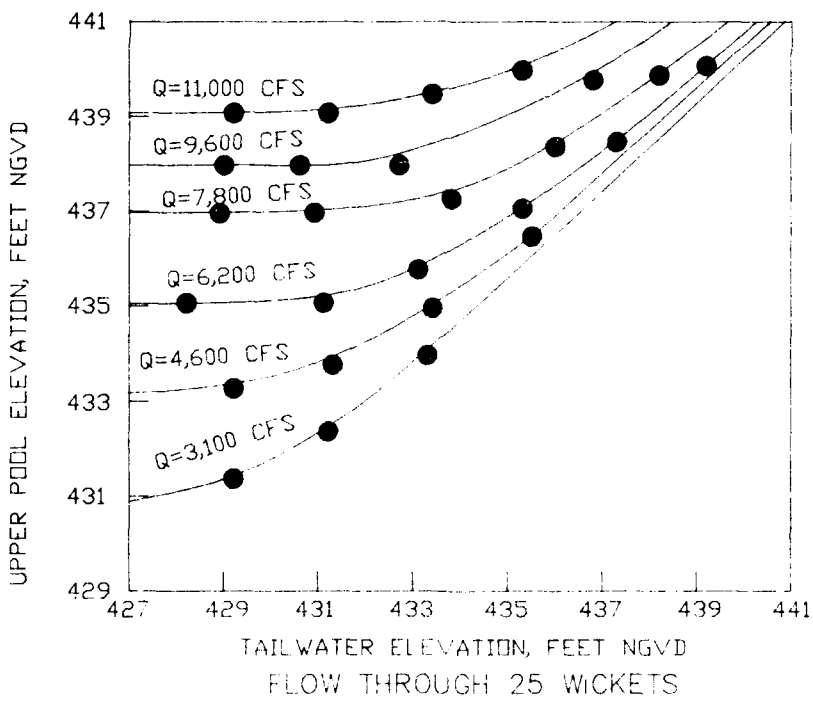
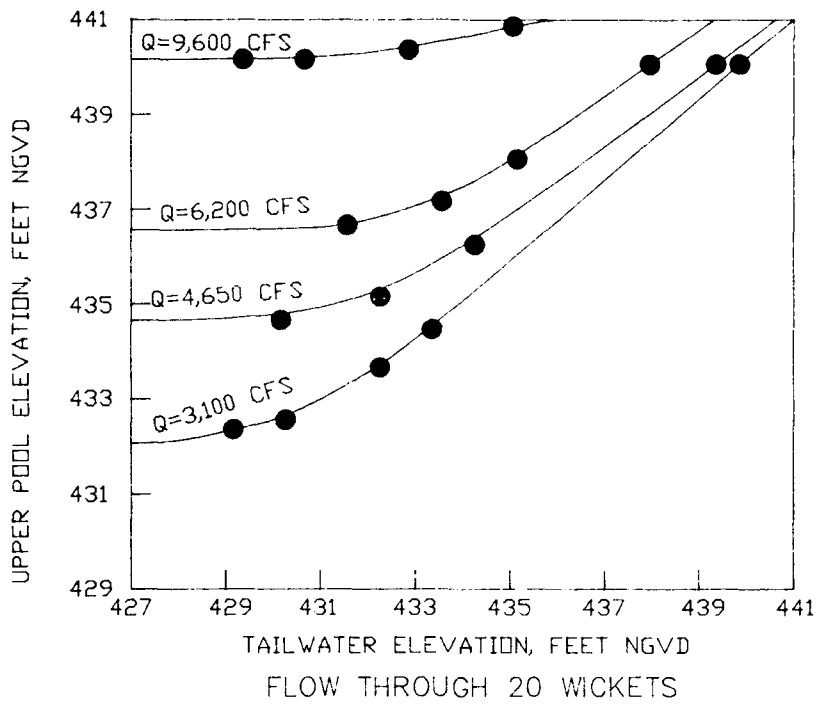

BASIC CALIBRATION DATA
 WICKET SILL EL 424.6

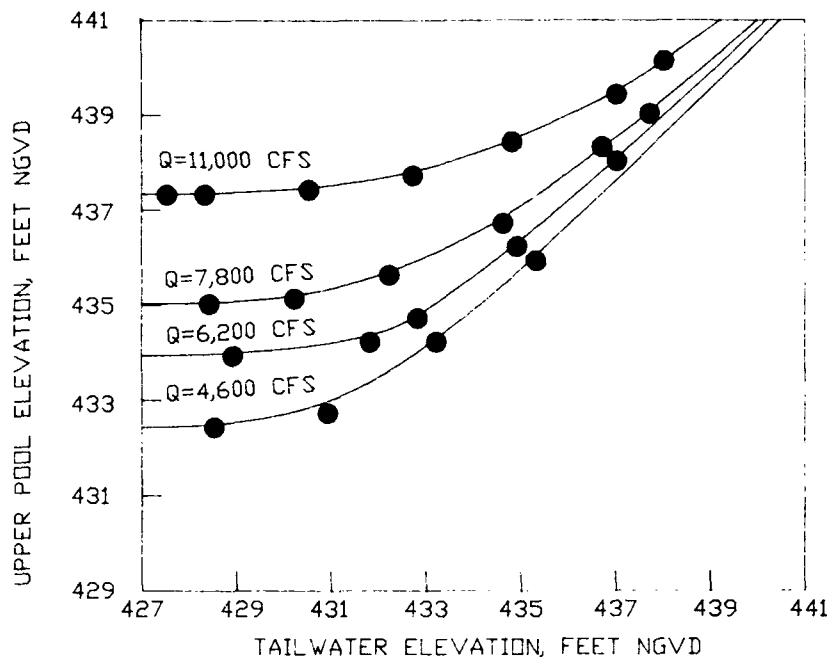

FLOW THROUGH 30 WICKETS

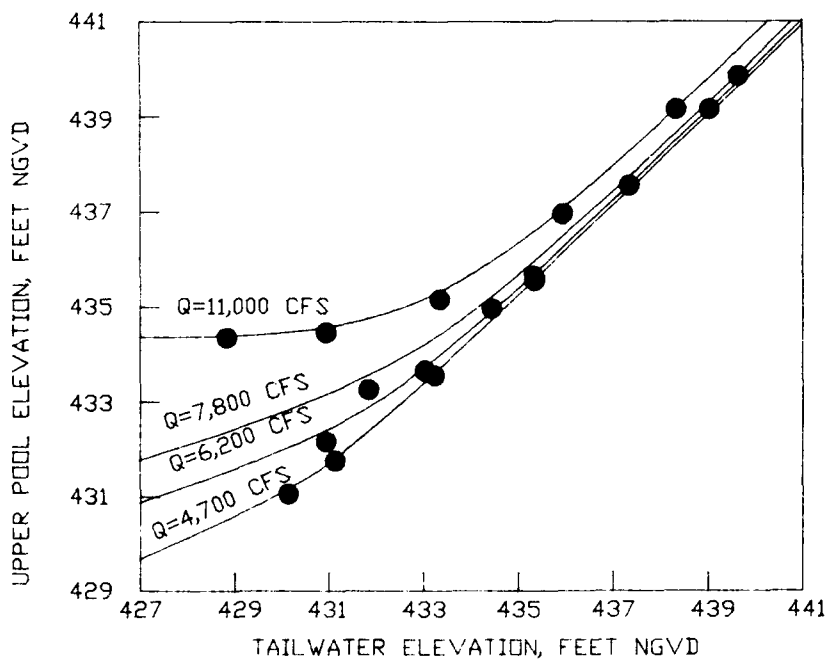

FLOW THROUGH 47 WICKETS

BASIC CALIBRATION DATA
WICKET SILL EL 424.6

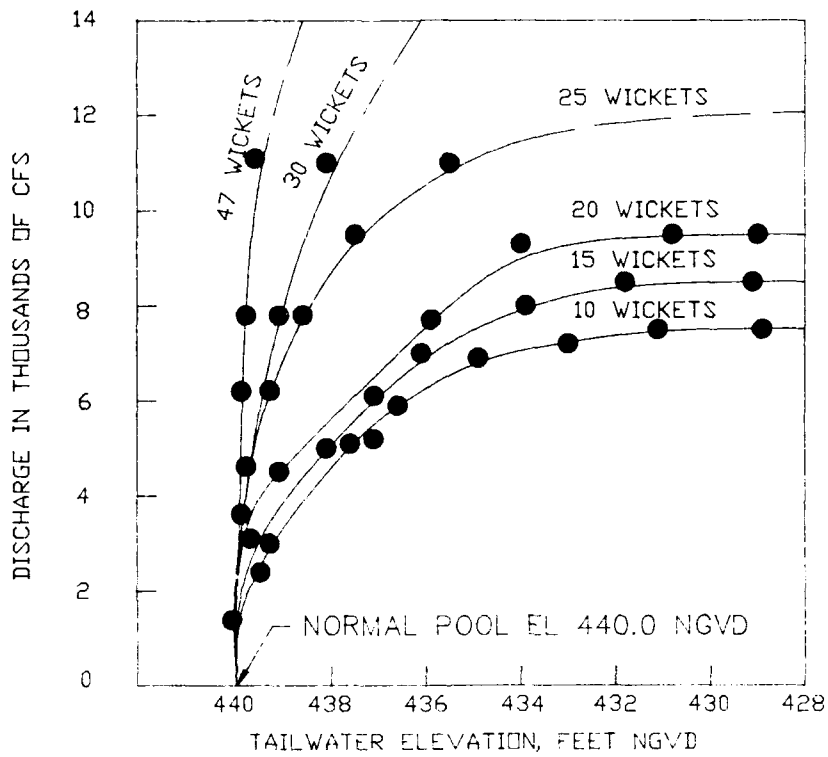

EFFECT OF TAILWATER ELEVATION
ON DISCHARGE
WICKET FLOW
POOL EL 440.0

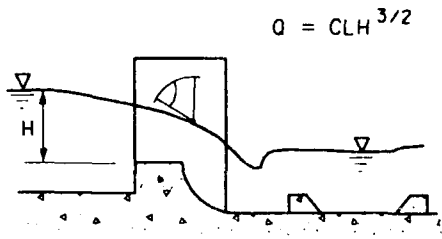

FREE UNCONTROLLED FLOW

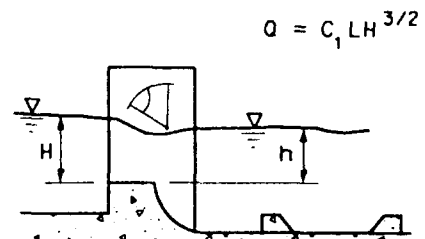

SUBMERGED UNCONTROLLED FLOW

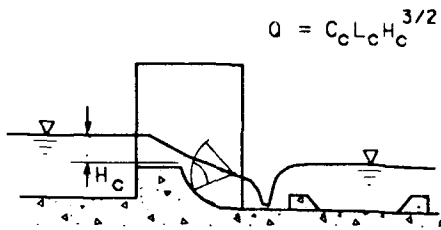

FREE UNCONTROLLED FLOW *
(OVER THE GATE)

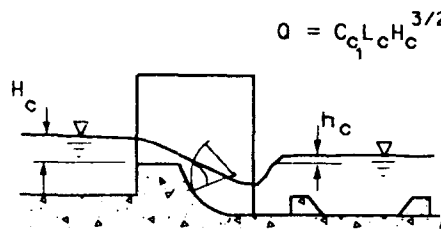

SUBMERGED UNCONTROLLED FLOW *
(OVER THE GATE)

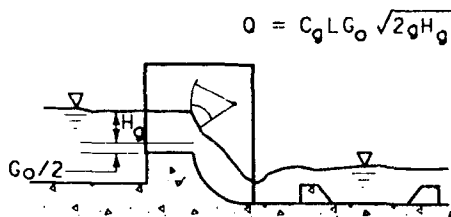

FREE CONTROLLED FLOW

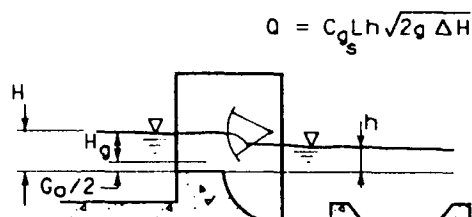

SUBMERGED CONTROLLED FLOW

* NOTE: FLOW OVER GATE IS UNCONTROLLED FLOW BECAUSE GATE ACTS AS AN OGEE WEIR FIXED AT SEVERAL ELEVATIONS

WHERE:

- Q = TOTAL DISCHARGE, CFS
- L = NET LENGTH OF SPILLWAY WEIR, FT
- H = GROSS HEAD ON SPILLWAY WEIR, FT
- h = DEPTH OF TAILWATER ABOVE SPILLWAY WEIR, FT
- L_c = NET LENGTH OF GATE CREST, FT
- H_c = GROSS HEAD ON GATE CREST, FT
- h_c = DEPTH OF TAILWATER ABOVE GATE CREST, FT
- G_o = GATE OPENING, FT
- g = ACCELERATION DUE TO GRAVITY, FT/SEC²
- H_g = GROSS HEAD ON GATE (H - G_o/2), FT
- ΔH = DIFFERENTIAL BETWEEN GROSS HEAD ON SPILLWAY WEIR AND DEPTH OF TAILWATER REFERENCED TO THE WEIR (H - h), FT

FLOW REGIMES

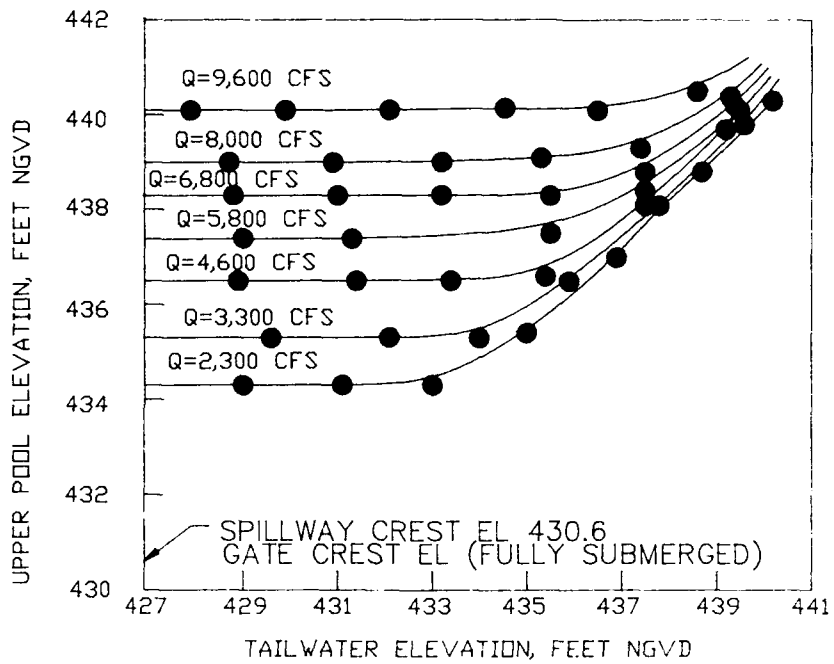

NOTE: TWO 60-FT-WIDE GATES

BASIC CALIBRATION DATA
 FLOW OVER TWO GATES
 FULLY SUBMERGED
 TYPE 1 DESIGN STRUCTURE

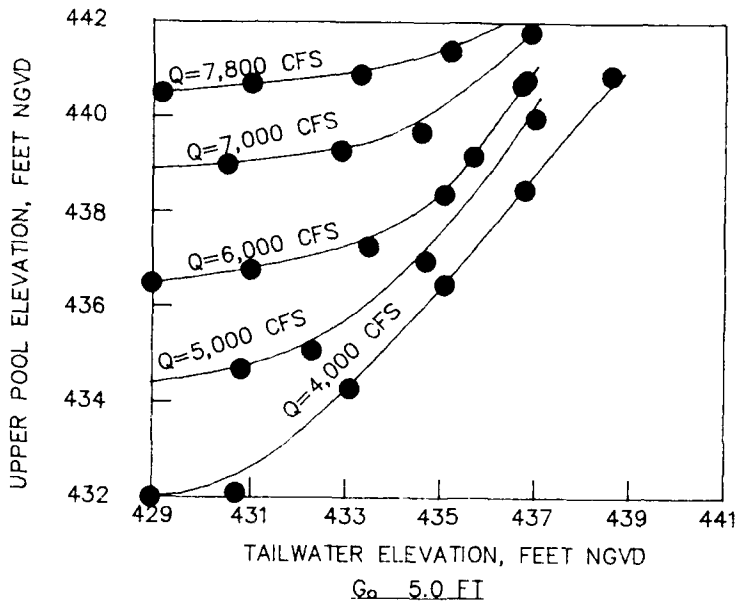
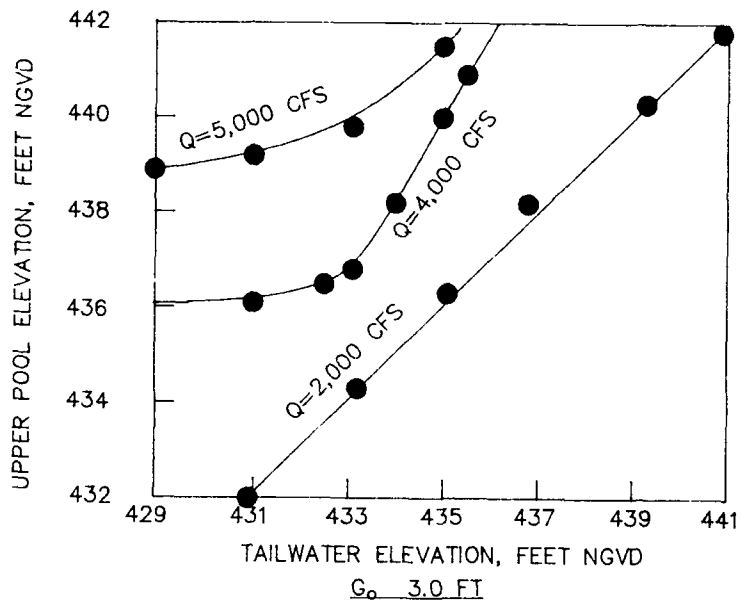

BASIC CALIBRATION DATA

TYPE 2 SPILLWAY CREST
 ONE 84-FT-WIDE GATE
 SPILLWAY CREST EL 426.5

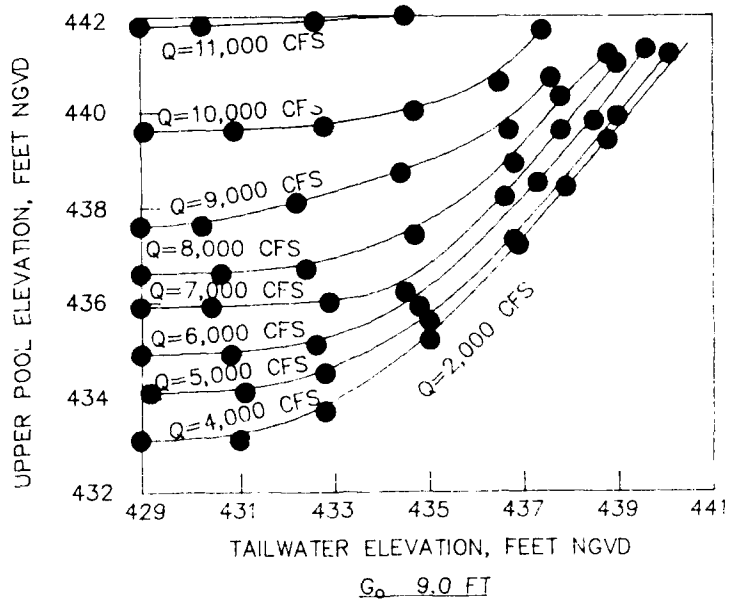
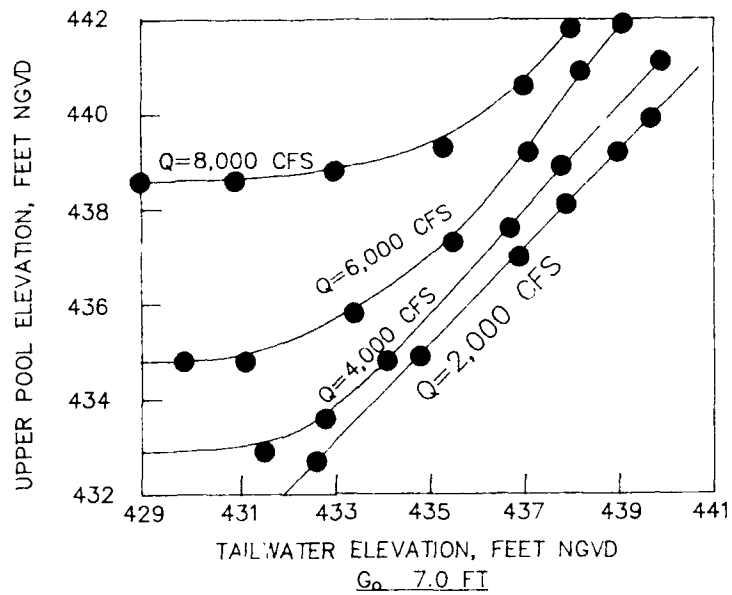

BASIC CALIBRATION DATA

TYPE 2 SPILLWAY CREST

ONE 84-FT-WIDE GATE

SPILLWAY CREST EL 426.5

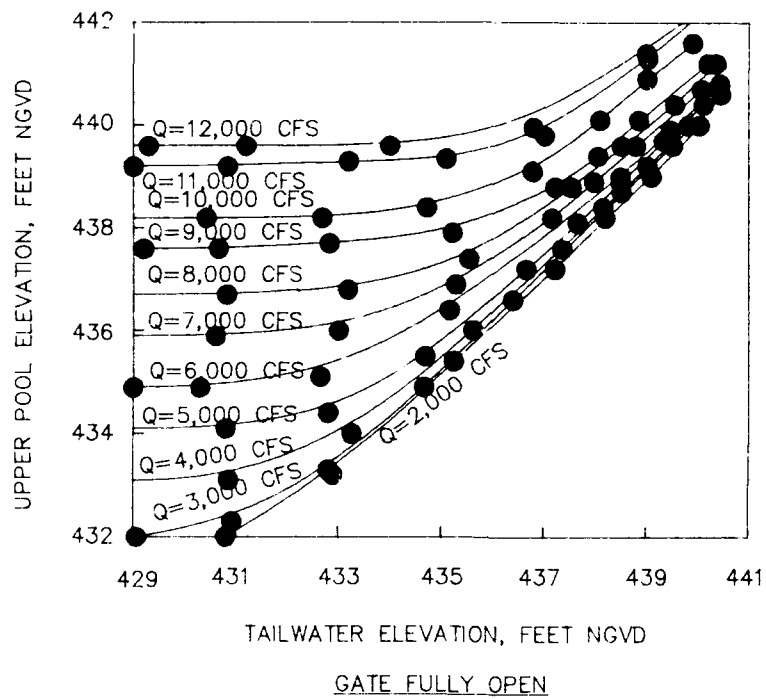

BASIC CALIBRATION DATA
 TYPE 2 SPILLWAY CREST
 ONE 94-FT-WIDE GATE
 SPILLWAY CREST EL 426.5

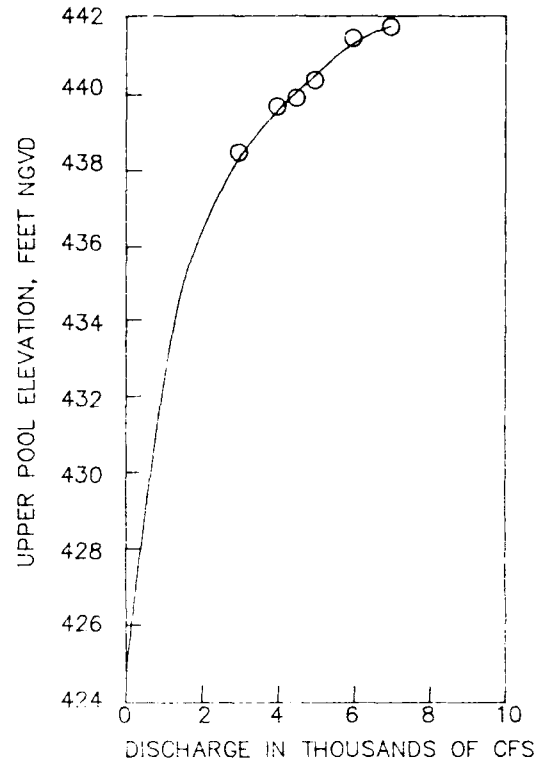
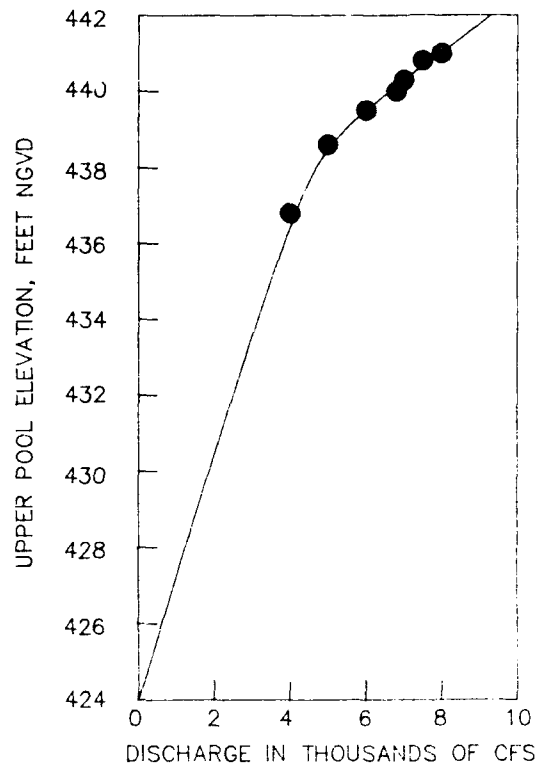

LEGEND

- FLOW THROUGH PIER AND SILL
- PIER AND SILL CLEARANCES SEALED

DISCHARGE RATING CURVE

FREE FLOW OVER GATE
 TYPE 2 SPILLWAY CREST
 GATE CREST EL. 432.0
 FLOW OVER ONE GATE

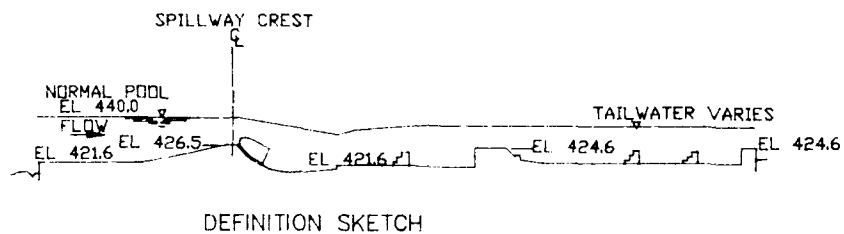
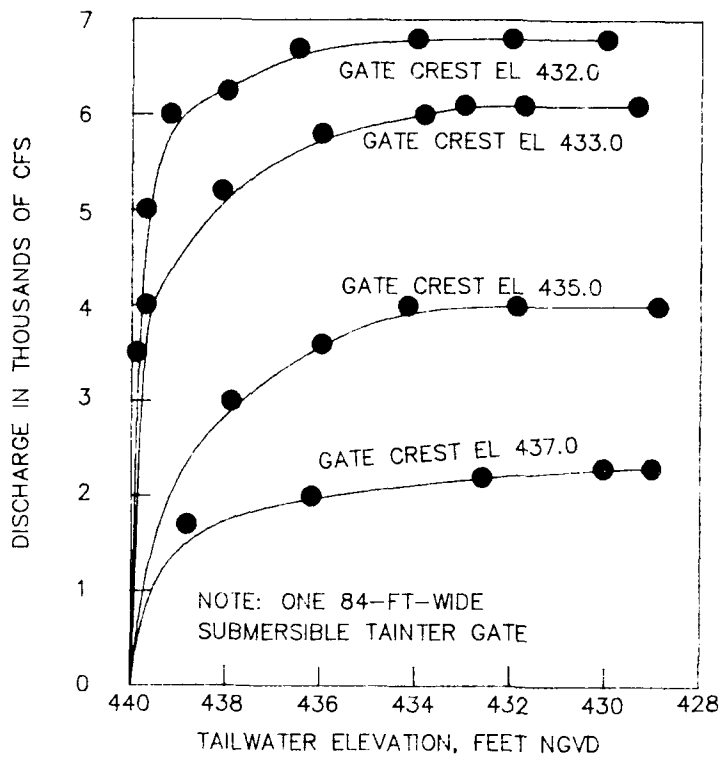

**EFFECT OF
TAILWATER ELEVATION
ON DISCHARGE**
TYPE 2 SPILLWAY
FLOW OVER ONE GATE
POOL EL 440

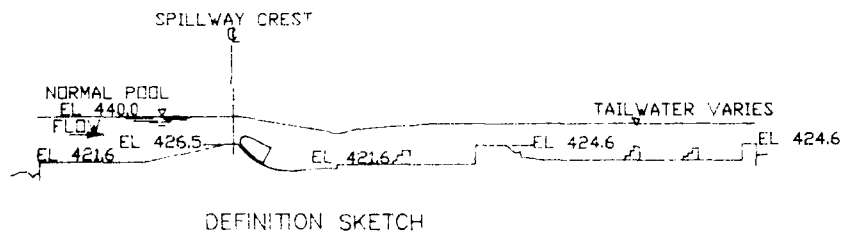
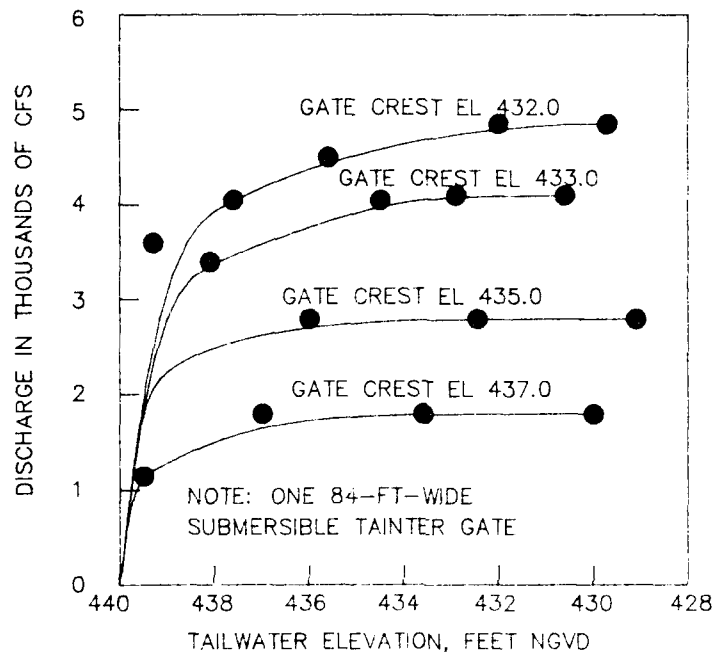

EFFECT OF TAILWATER ELEVATION ON DISCHARGE

TYPE 2 SPILLWAY
FLOW OVER ONE GATE
PIER AND SILL
CLEARANCES SEALED
POOL EL 440

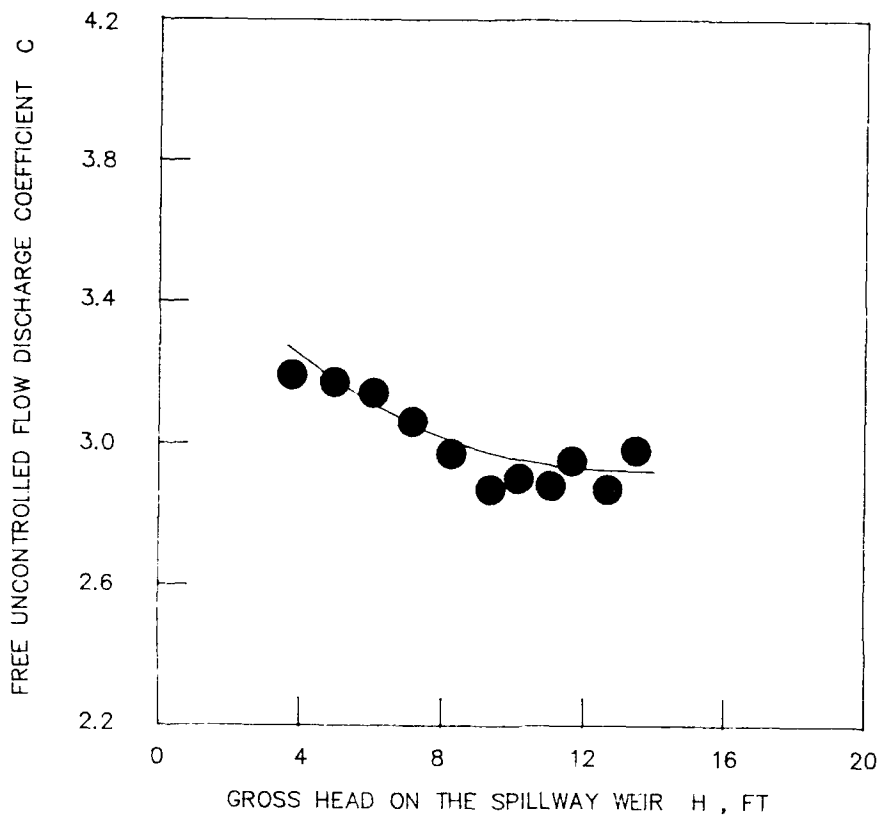

DISCHARGE COEFFICIENTS
FREE UNCONTROLLED FLOW
 TYPE 2 SPILLWAY CREST
 FLOW THROUGH ONE
 84-FT-WIDE GATE BAY
 PIER AND SILL CLEARANCES
 SEALED

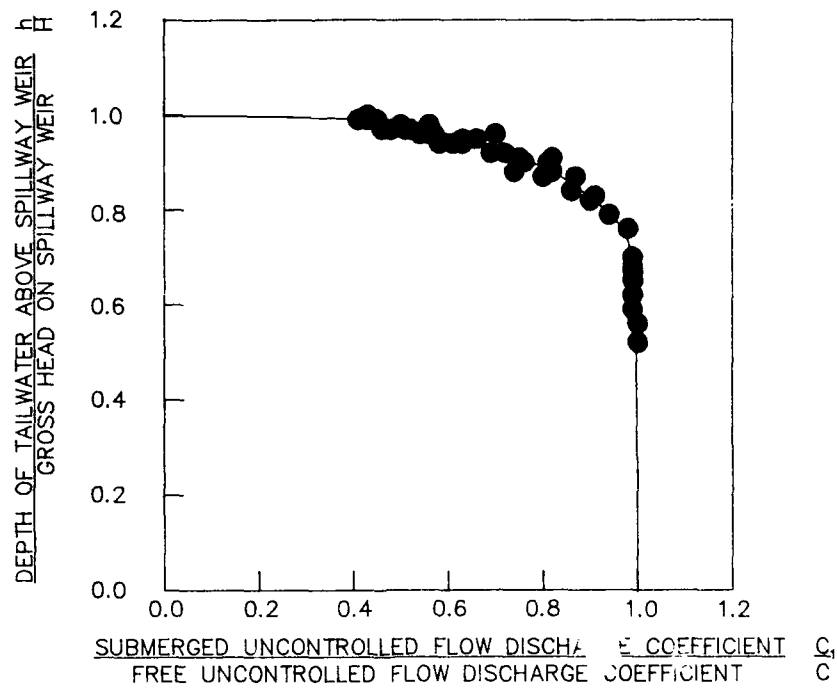

**DISCHARGE COEFFICIENTS
SUBMERGED UNCONTROLLED FLOW**

TYPE 2 SPILLWAY CREST
FLOW THROUGH
ONE 84-FT-WIDE GATE BAY
PIER AND SILL CLEARANCES
SEALED

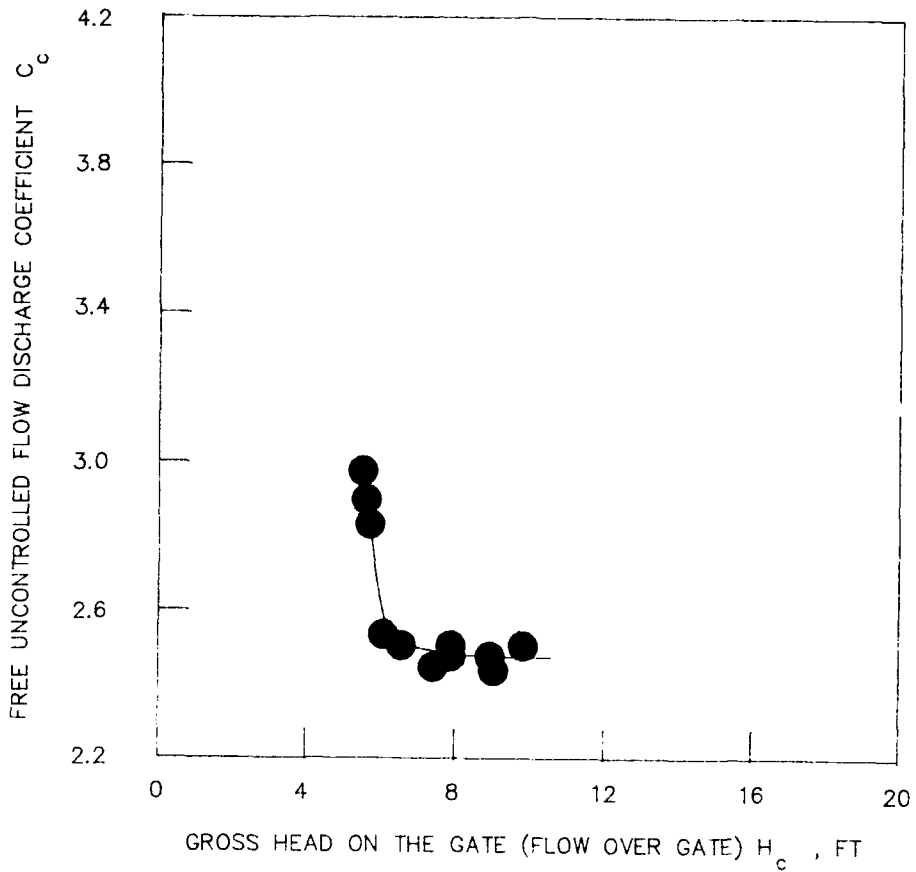

DISCHARGE COEFFICIENTS
FREE UNCONTROLLED
FLOW OVER GATE
 TYPE 2 SPILLWAY CREST
 PIER AND SILL CLEARANCES
 SEALED
 FLOW OVER ONE GATE

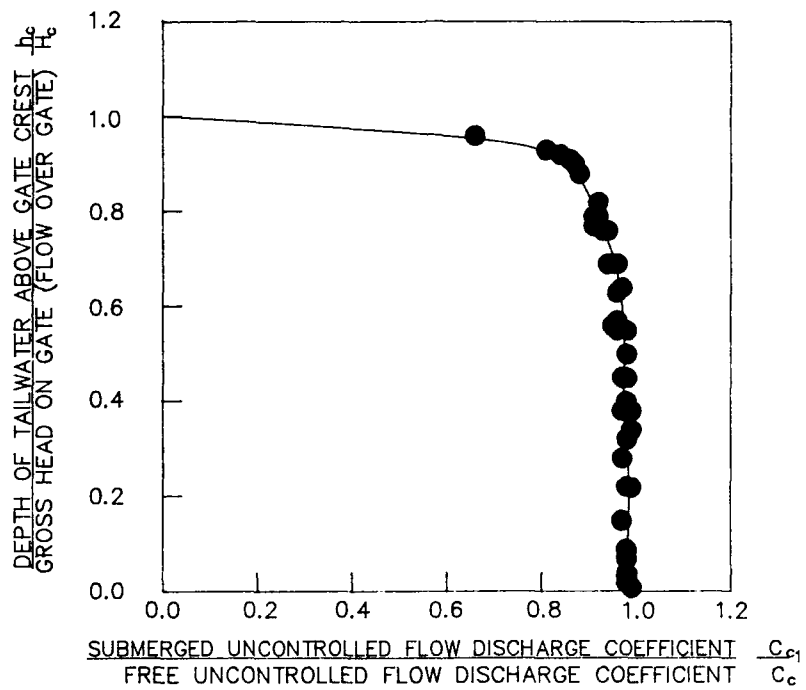

**DISCHARGE COEFFICIENTS
SUBMERGED UNCONTROLLED FLOW
OVER GATE**
TYPE 2 SPILLWAY CREST
PIER AND SILL CLEARANCES
SEALED
FLOW OVER ONE GATE

FREE CONTROLLED FLOW DISCHARGE COEFFICIENT C_g

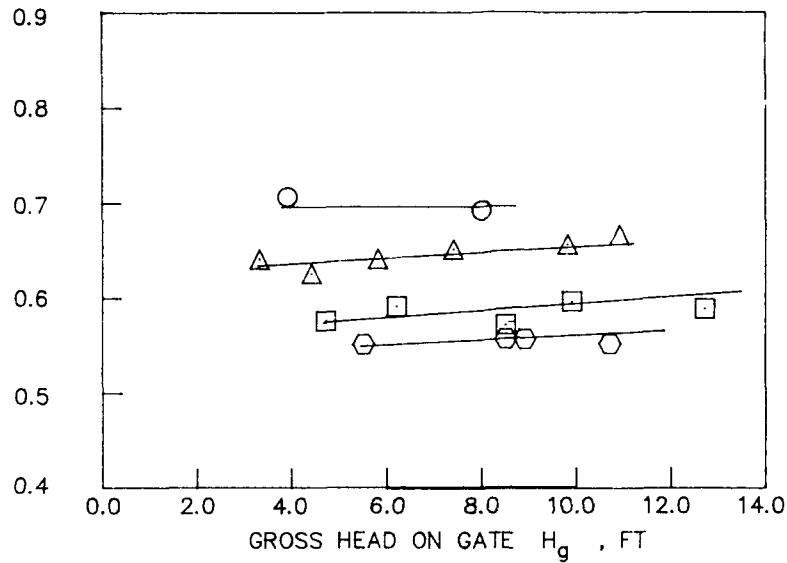

LEGEND

- 3-FT GATE OPENING
- △ 5-FT GATE OPENING
- 7-FT GATE OPENING
- ⬡ 9-FT GATE OPENING

**DISCHARGE COEFFICIENTS
FREE CONTROLLED FLOW**

TYPE 2 SPILLWAY CREST
FLOW UNDER
ONE 84-FT-WIDE GATE

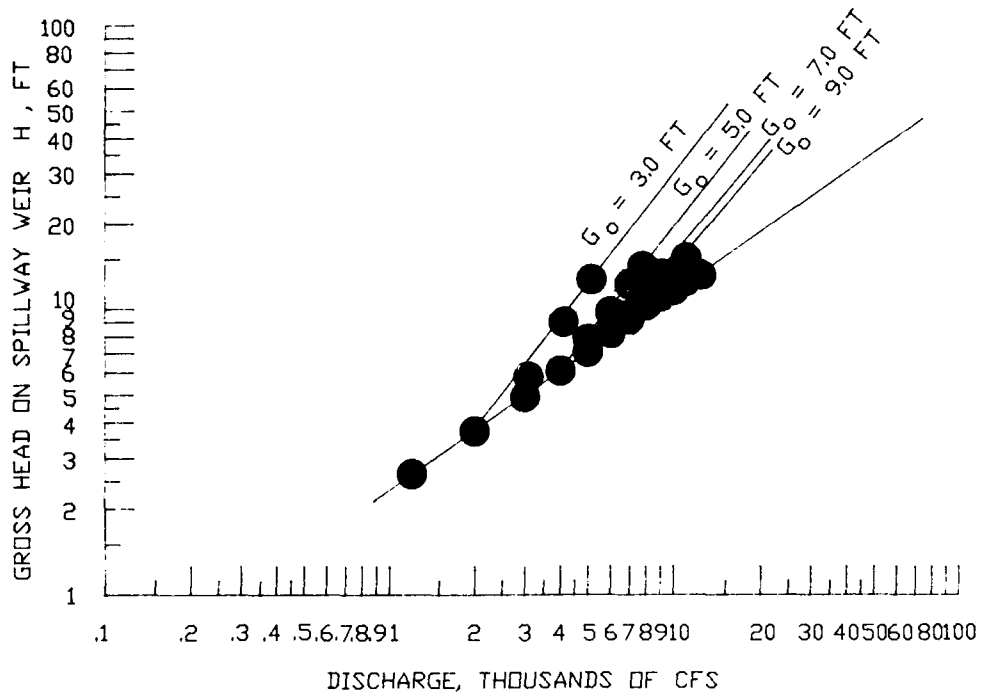

**DISCHARGE-HEAD
RELATIONSHIP FOR
FREE FLOW
TYPE 2 SPILLWAY CREST
FLOW UNDER ONE
84-FT-WIDE GATE**

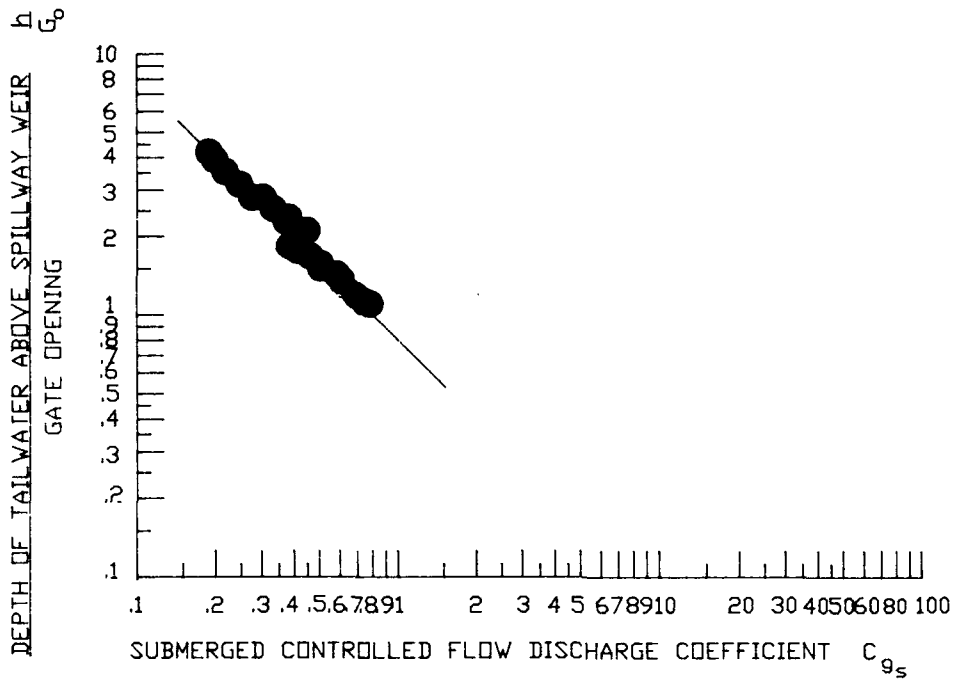

DISCHARGE COEFFICIENTS
 FOR
 SUBMERGED CONTROLLED FLOW
 TYPE 2 SPILLWAY CREST

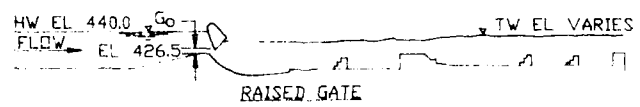
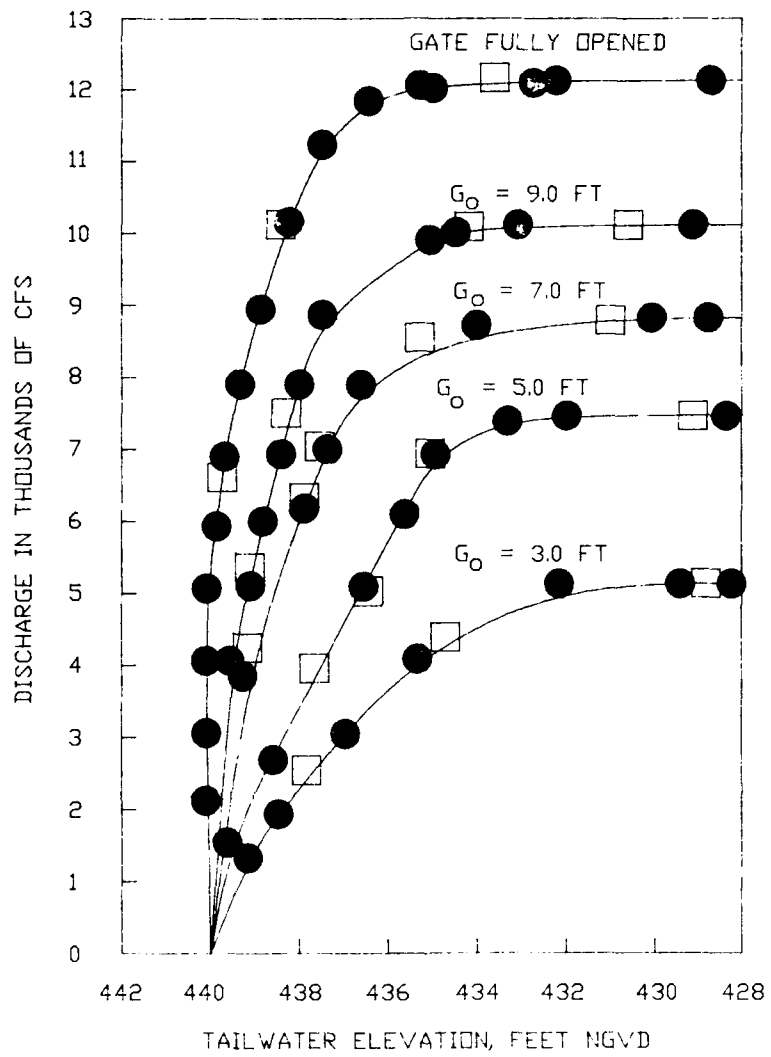

- LEGEND**
- TYPE 2 STRUCTURE
 - TYPE 3 STRUCTURE

EFFECT OF TAILWATER ELEVATION ON DISCHARGE
 FLOW UNDER ONE GATE
 TYPES 2 AND 3 STRUCTURES
 POOL FL 440

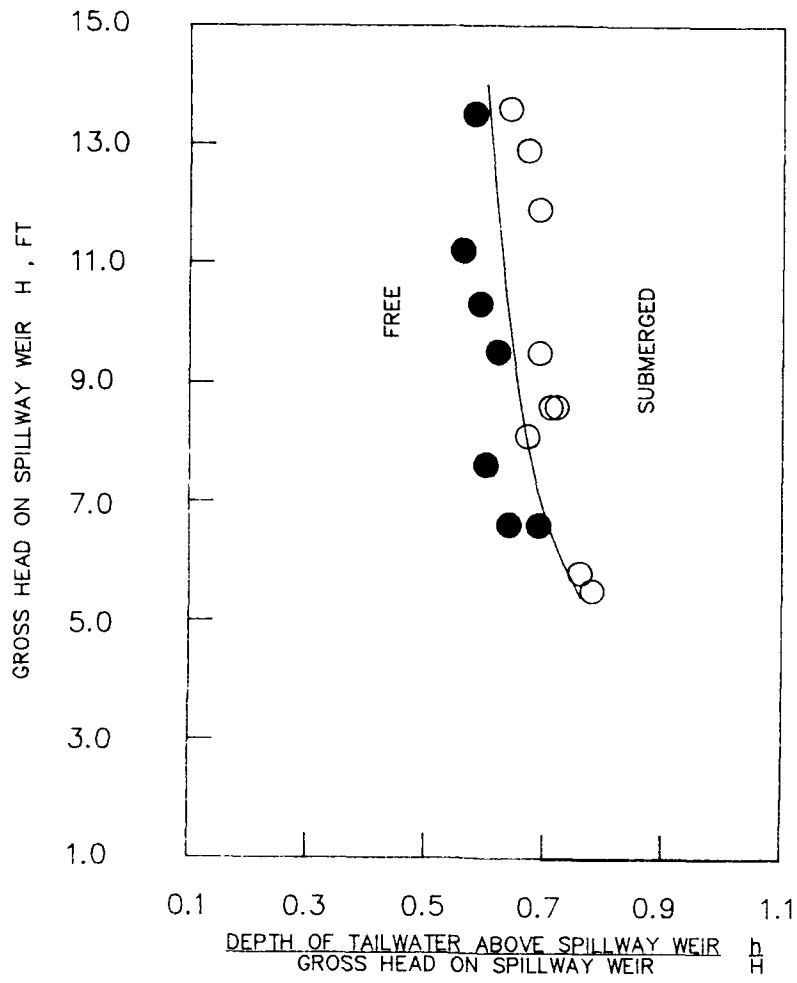

**UNCONTROLLED FLOW
REGIMES**
FLOW OVER SPILLWAY
TYPE 2 SPILLWAY CREST

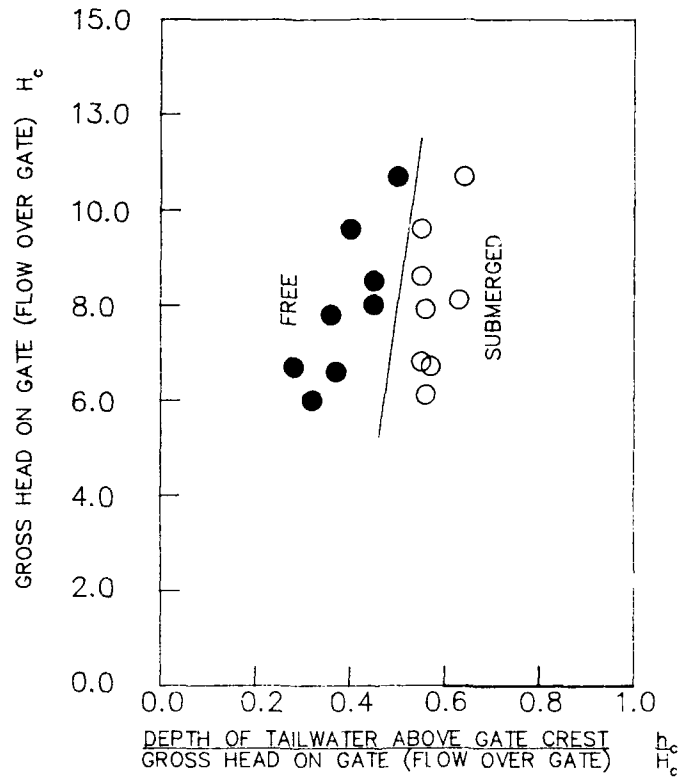

NOTE: GROSS HEAD ON GATE CREST EQUALS
DIFFERENCE IN POOL ELEVATION
AND GATE CREST ELEVATION

**UNCONTROLLED FLOW
REGIMES**
FLOW OVER GATE
TYPE 2 SPILLWAY CREST

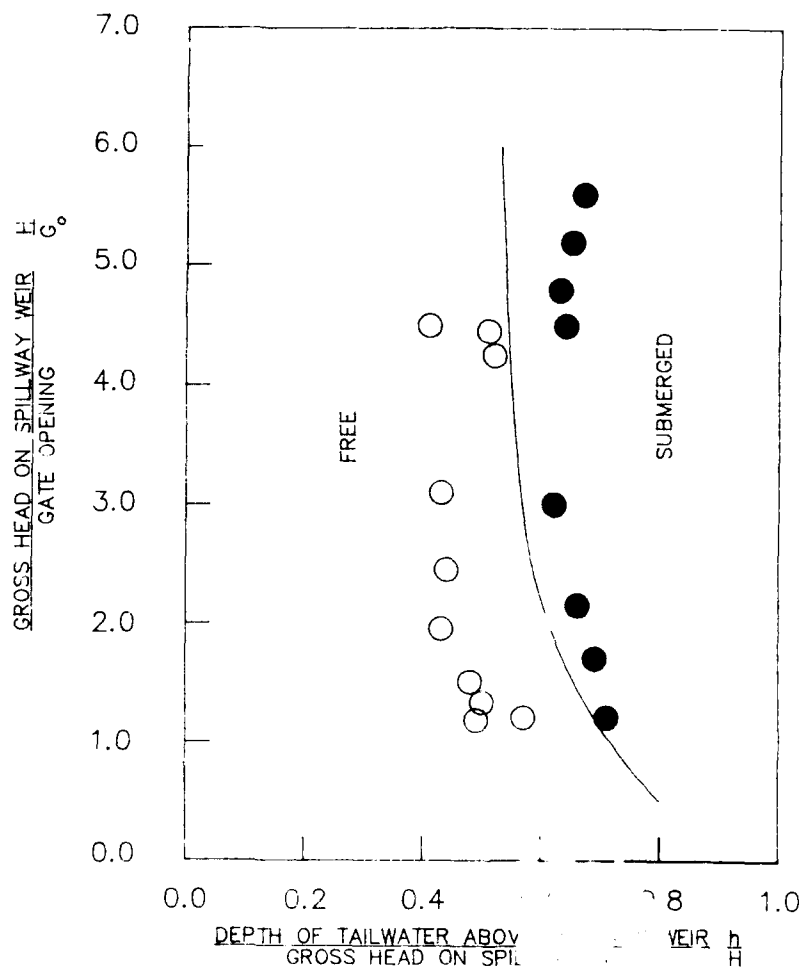

CONTROLLED FLOW
REGIMES
TYPE 2 SPILLWAY CREST

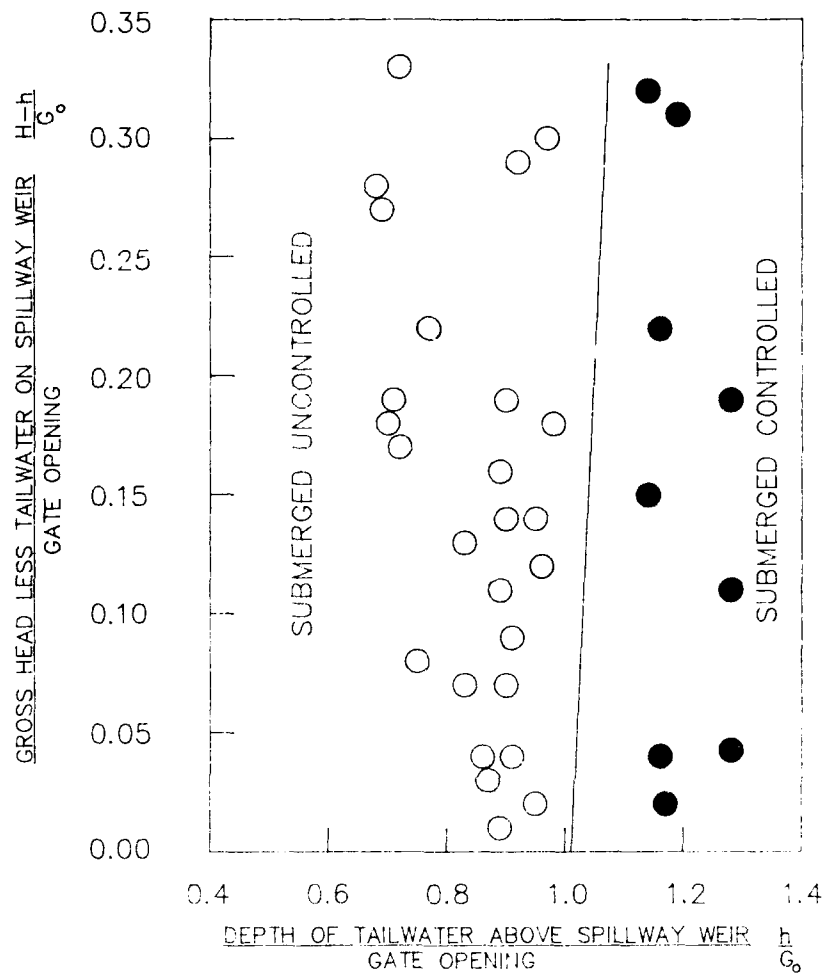

SUBMERGED FLOW
REGIMES

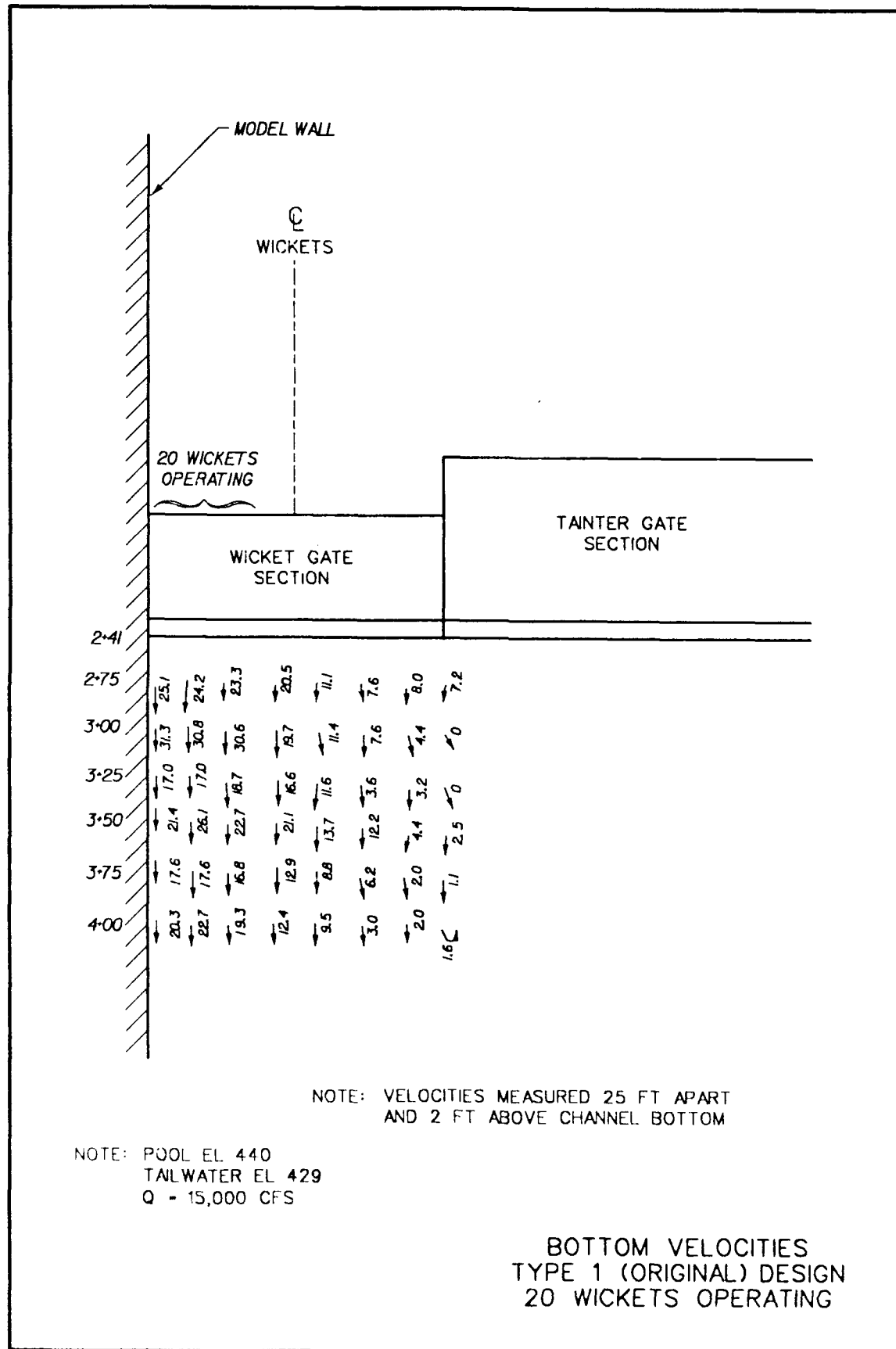

NOTE: VELOCITIES 10 FT APART

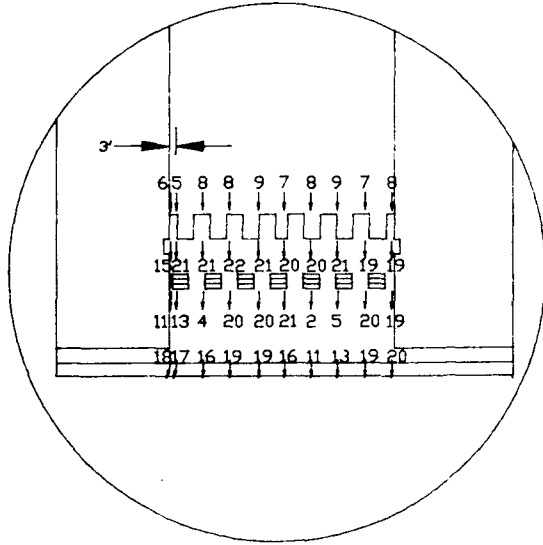

DETAIL 'A'

WICKET
GATE SECTION

SEE DETAIL 'A'

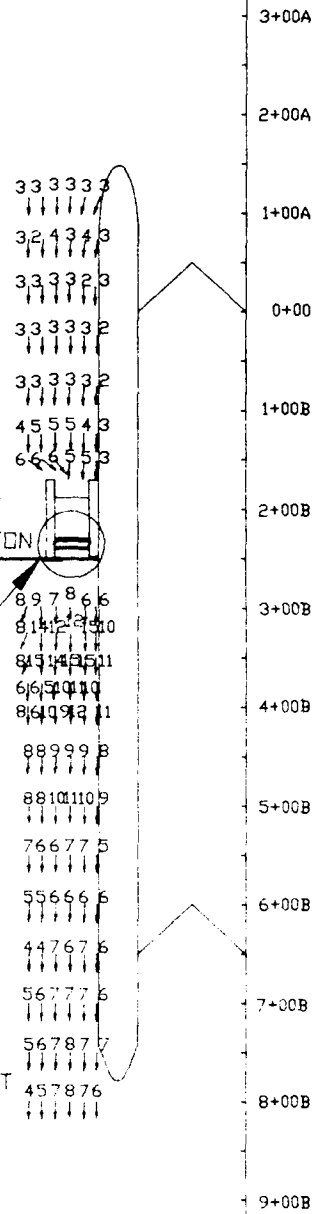

NOTE: VELOCITIES 20 FT APART

BOTTOM VELOCITIES
TYPE 2 DESIGN STRUCTURE
 GATE FULLY OPEN
 P.W. EL. 440
 T.W. EL. 429

NOTE: VELOCITIES 10 FT APART

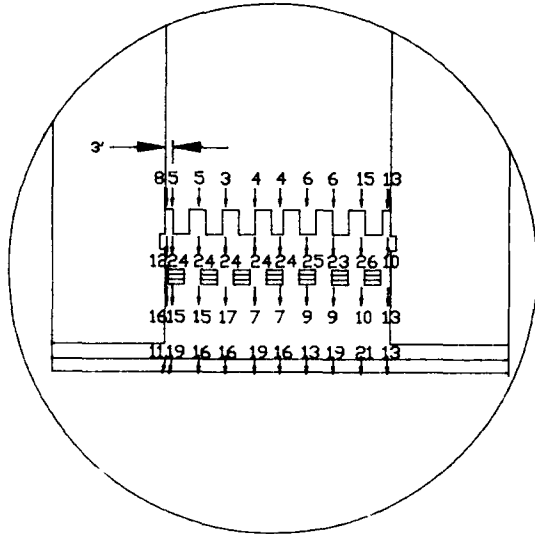

DETAIL "A"

WICKET
GATE SECTION

SEE DETAIL "A"

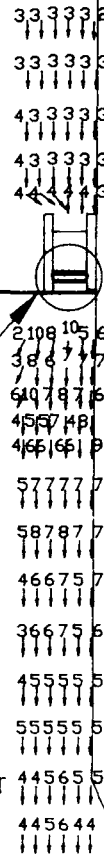

NOTE: VELOCITIES 20 FT APART

BOTTOM VELOCITIES
TYPE 2 DESIGN STRUCTURE
 GATE FULLY SUBMERGED
 POOL EL 440
 TW EL 429

NOTE: POOL EL 440
 TAILWATER EL 429
 Q= 6,800 cfs

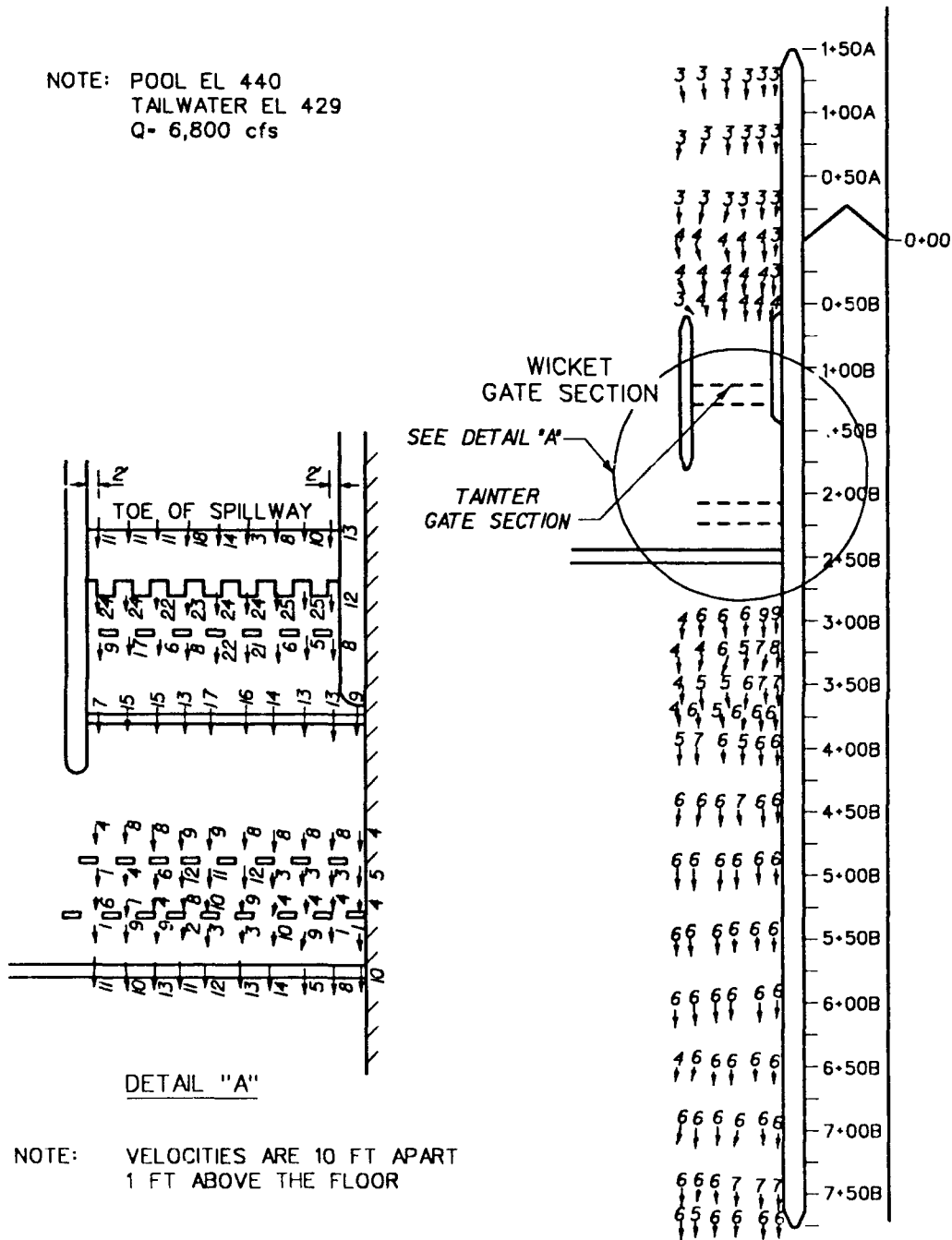

DETAIL "A"

NOTE: VELOCITIES ARE 10 FT APART
 1 FT ABOVE THE FLOOR

NOTE: VELOCITIES ARE 20 FT APART
 1 FT ABOVE THE FLOOR

TYPE 3 DESIGN STRUCTURE
 BOTTOM VELOCITIES
 GATE FULLY SUBMERGED

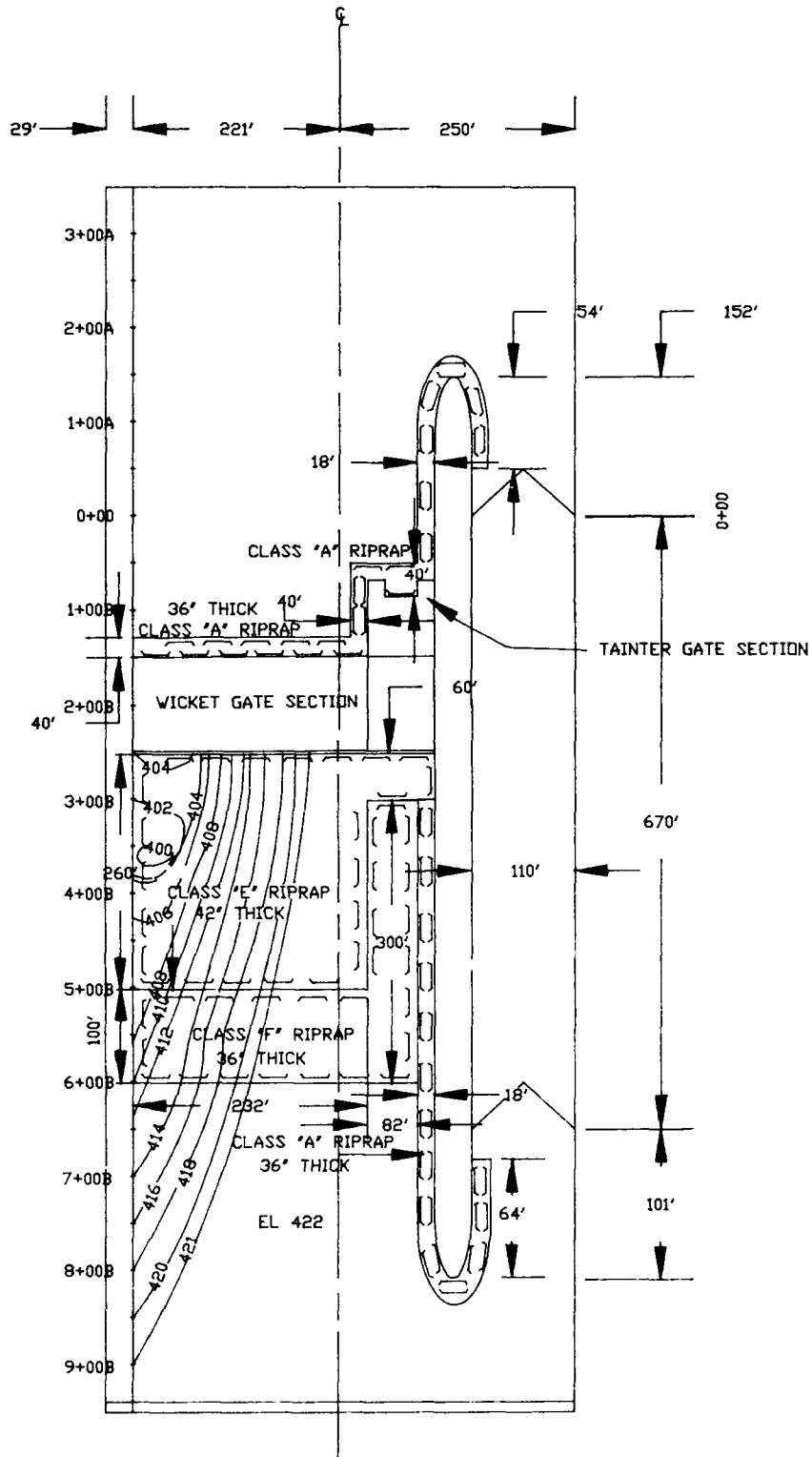

NOTE: PROTECTION DOWNSTREAM OF WICKET SECTION FOR PROTECTION AFTER SCOUR HOLE WAS ALLOWED TO DEVELOP.
 PROTECTION DOWNSTREAM OF TAINTER GATE SECTION FOR PROTECTION OF BED BEFORE SCOUR HOLE ALLOWED TO DEVELOP.

**RIPRAP PROTECTION DETAIL
 TYPE 3 DESIGN STRUCTURE**

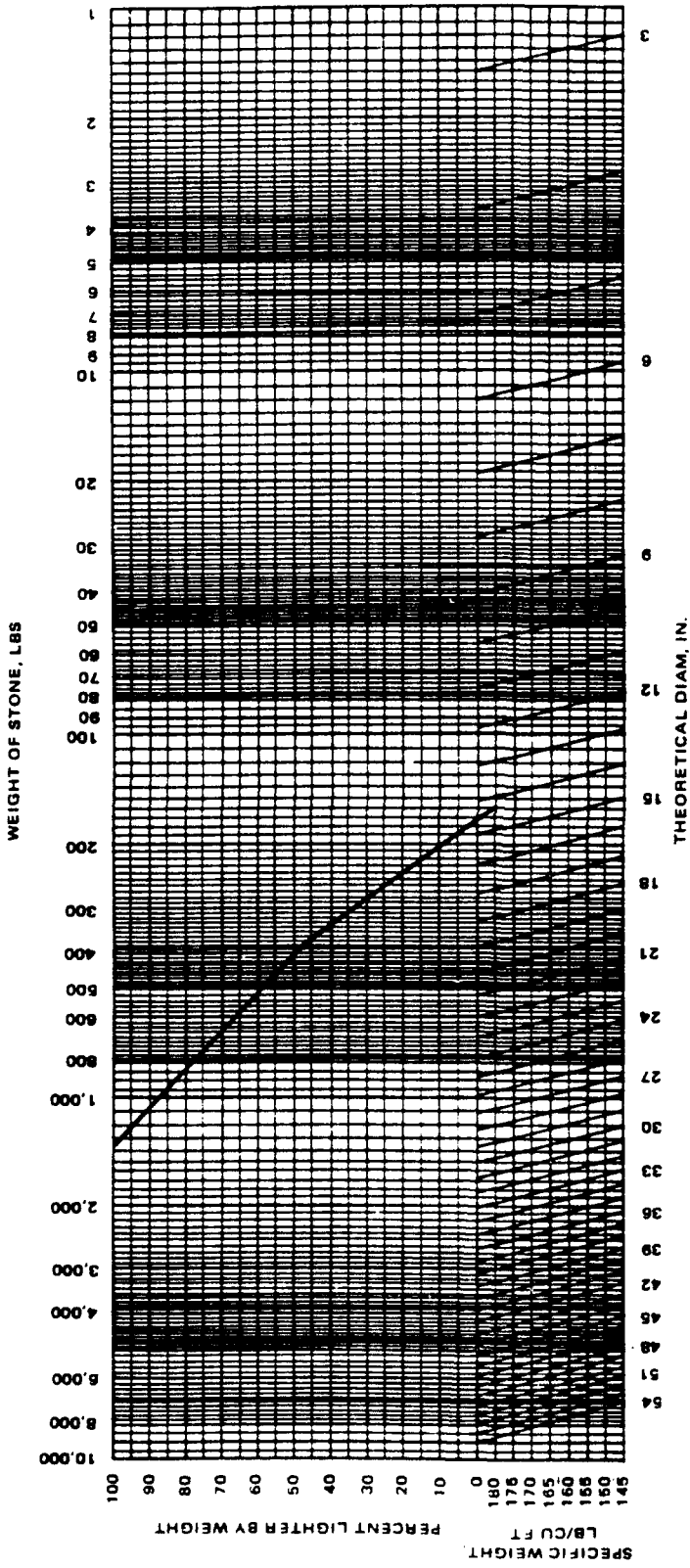

CLASS "A" RIPRAP
RIPRAP GRADATION CURVE

SPECIFIC WEIGHT OF STONE 165 LBS/CU FT

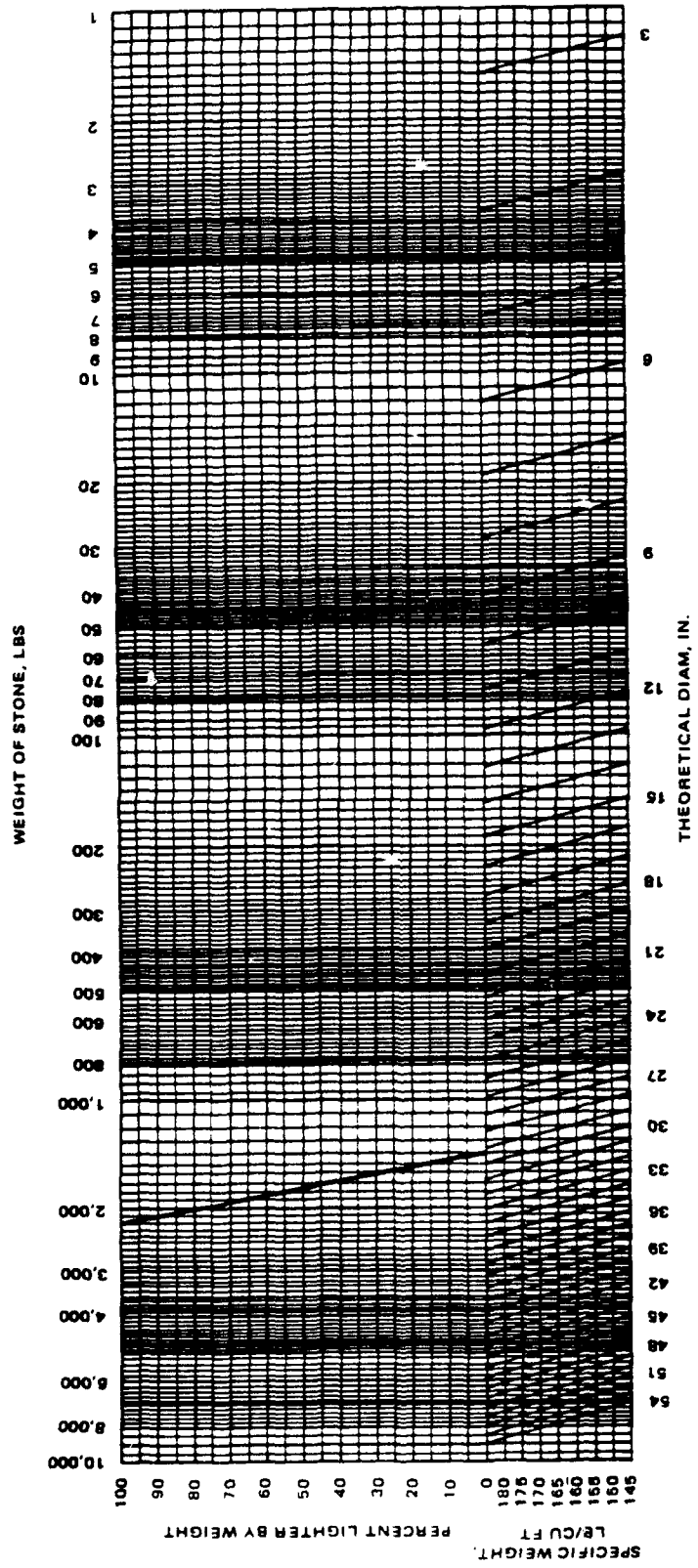

SPECIFIC WEIGHT OF STONE 165 LBS/CU FT

CLASS "E" RIPRAP
RIPRAP GRADATION CURVE

NOTE: UNIFORMLY GRADED RIPRAP

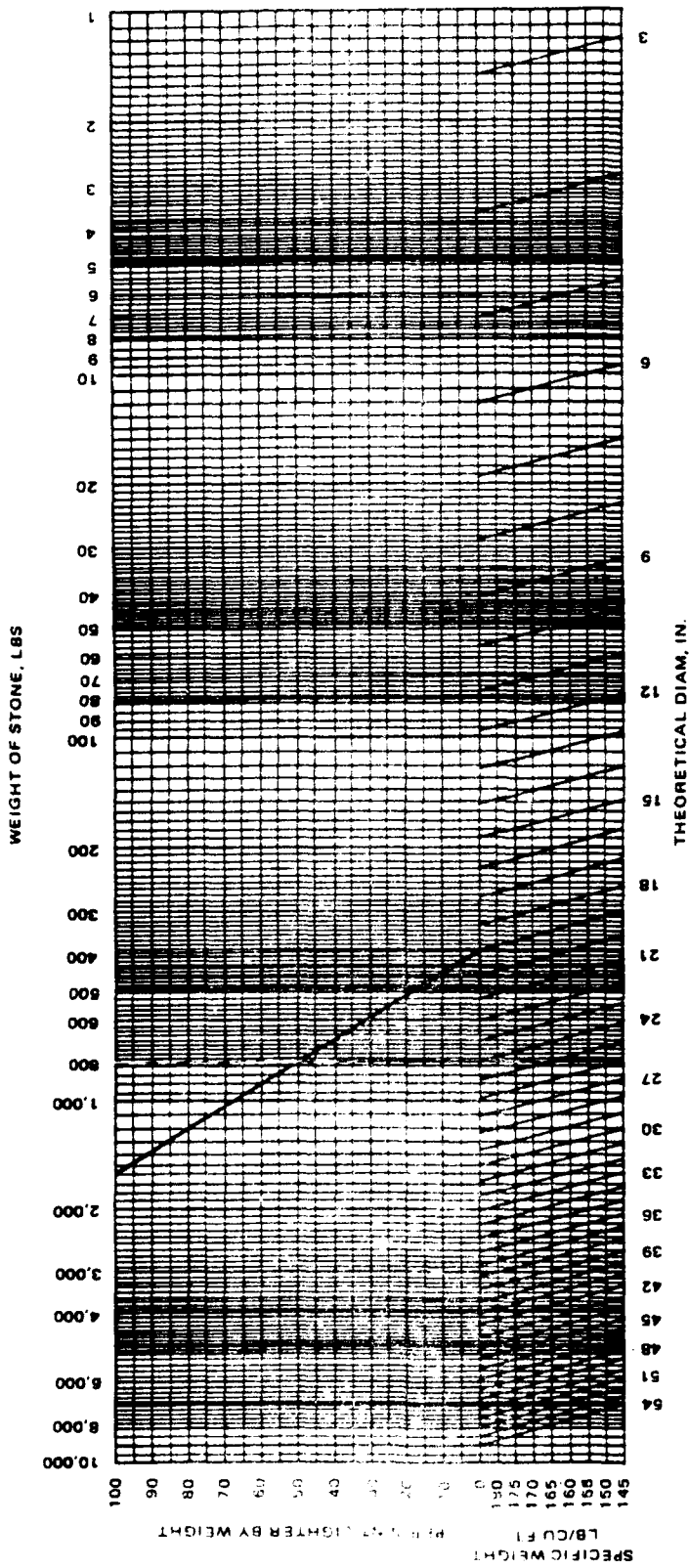

CLASS 'F' RIPRAP
RIPRAP GRADATION CURVE

SPECIFIC WEIGHT OF STONE 165 LBS/CU FT

NOTE: UNIFORMLY GRADED RIPRAP

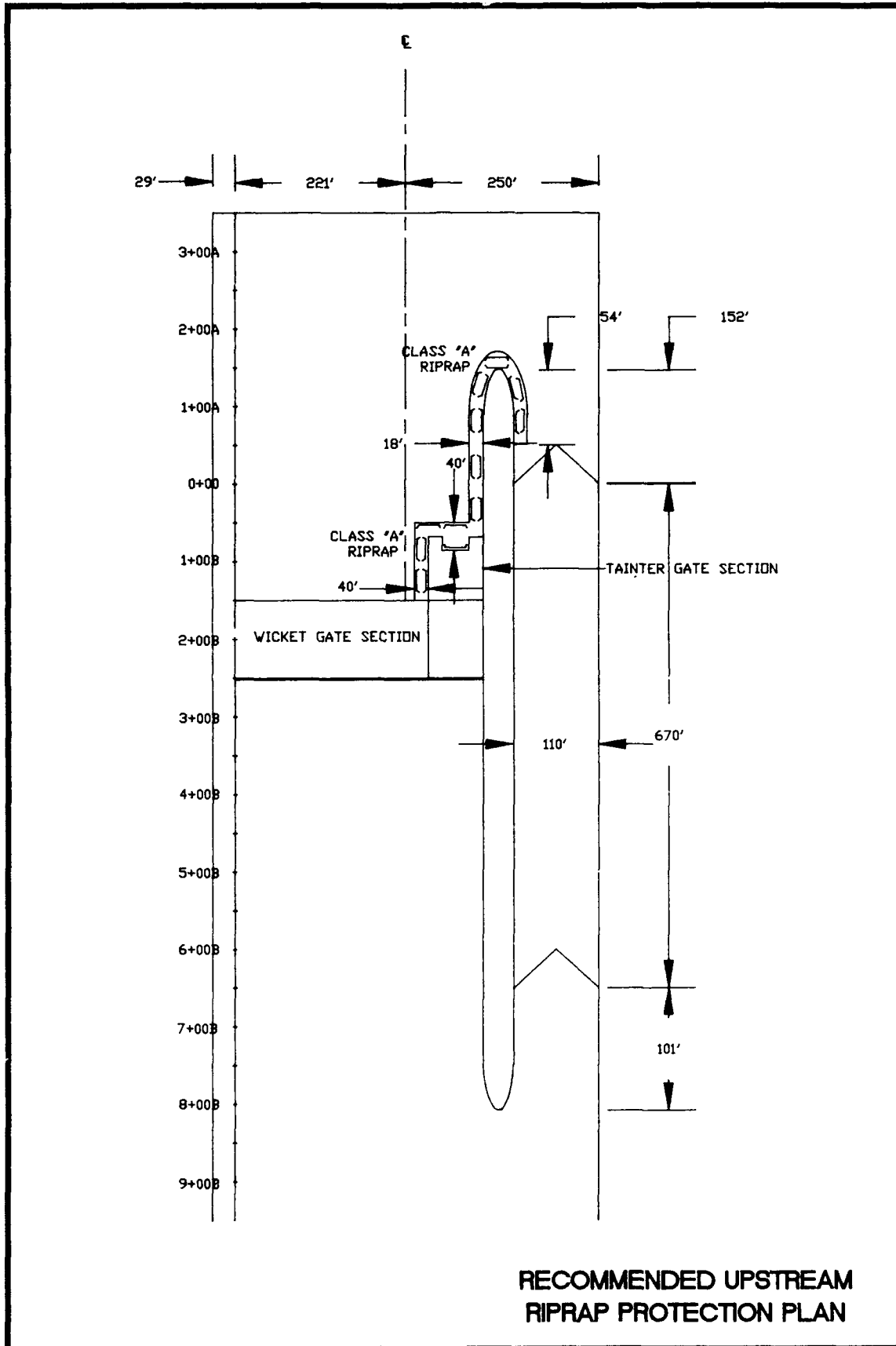

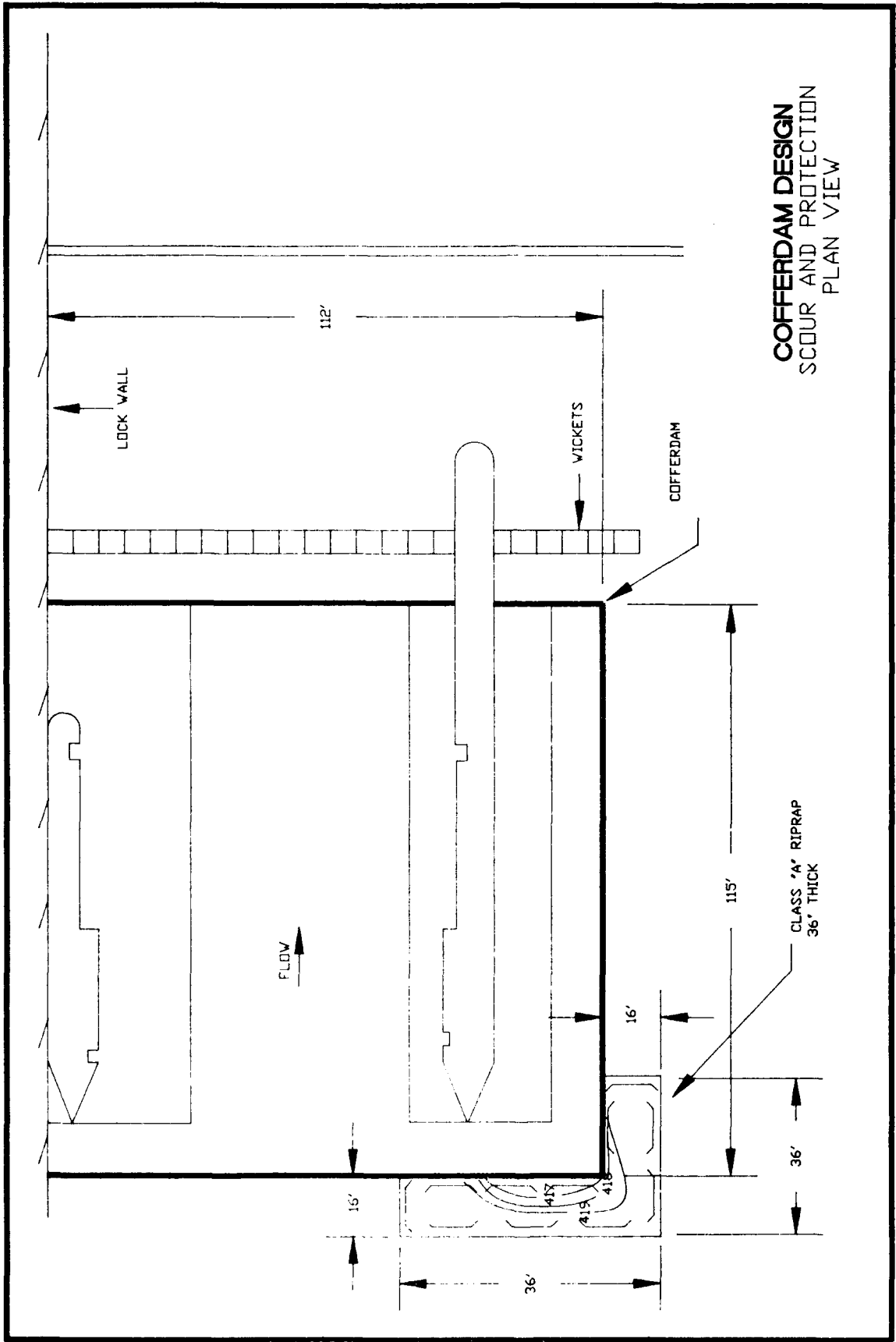

COFFERDAM DESIGN
 SCOUR AND PROTECTION
 PLAN VIEW

PLATE 36

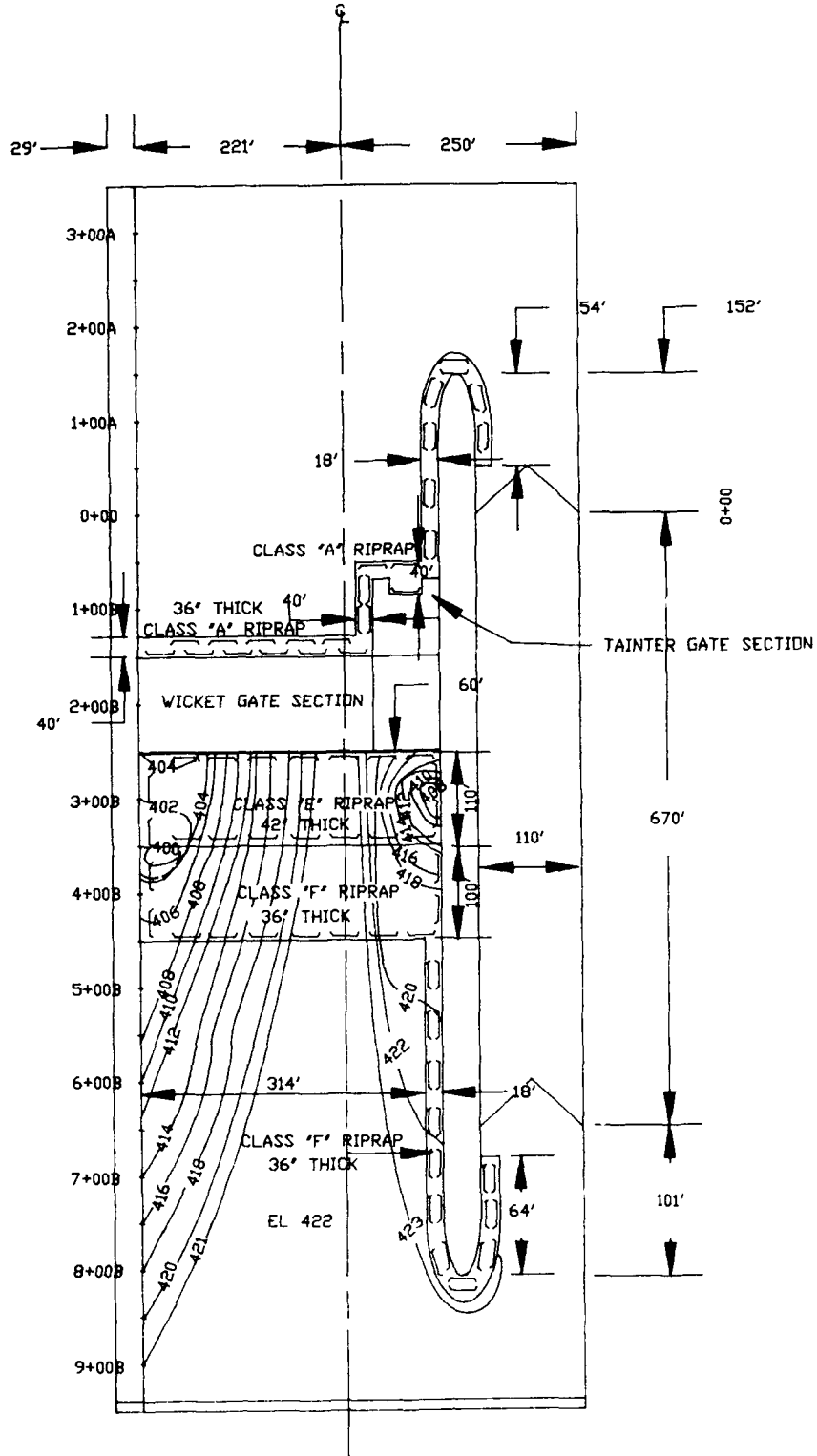

NOTE: PROTECTION DOWNSTREAM OF WICKET SECTION AND TAITNER GATE SECTION FOR PROTECTION AFTER SCOUR HOLES ALLOWED TO DEVELOP.

**RIPRAP PROTECTION DETAIL
POST-SCOUR CONDITIONS
TYPE 3 DESIGN STRUCTURE**

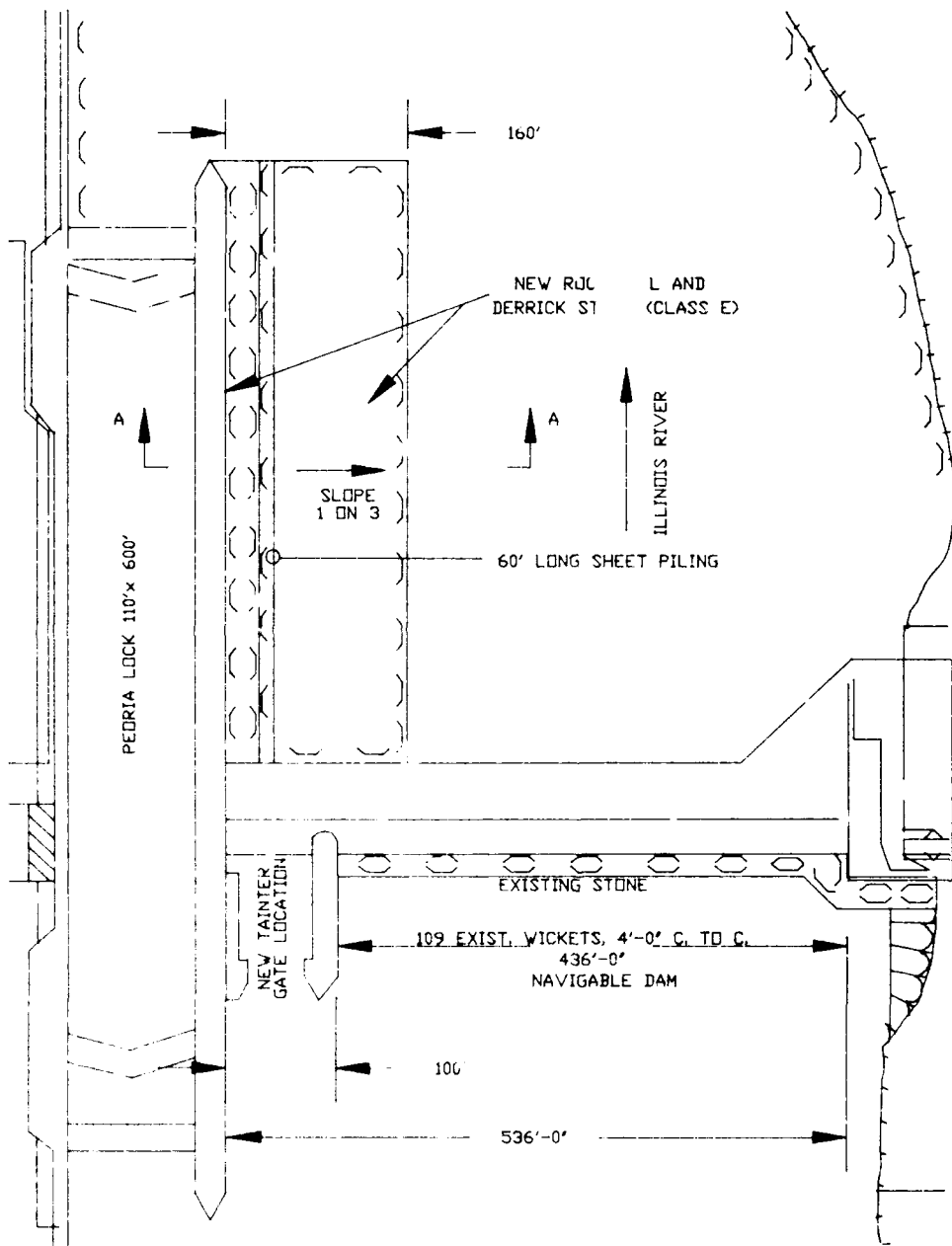

NOTE: SEE PLATE 39 FOR SECTION A-A

**REVISED RIPRAP
PROTECTION PLAN**

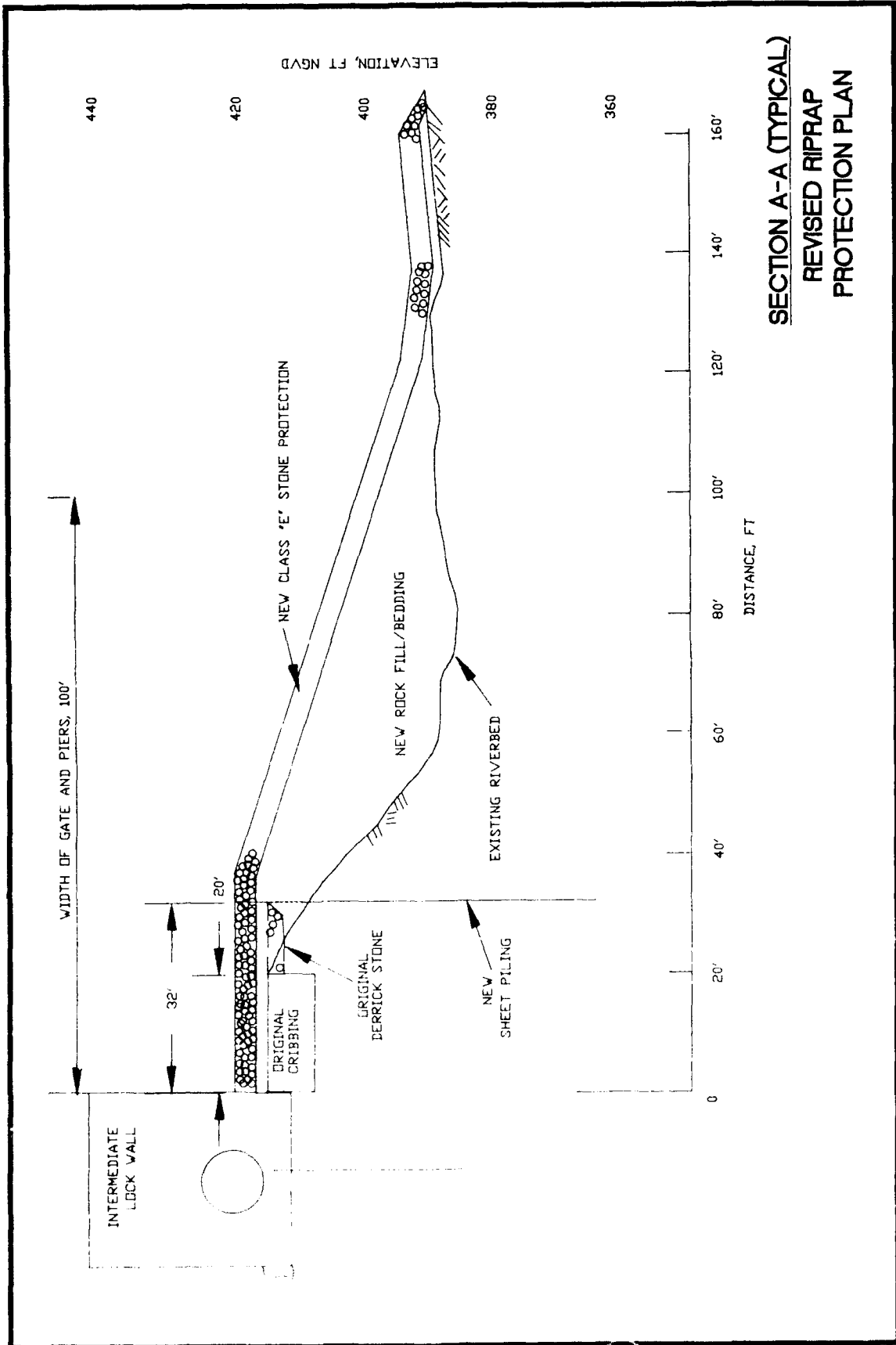

SECTION A-A (TYPICAL)
REVISED RIPRAP
PROTECTION PLAN

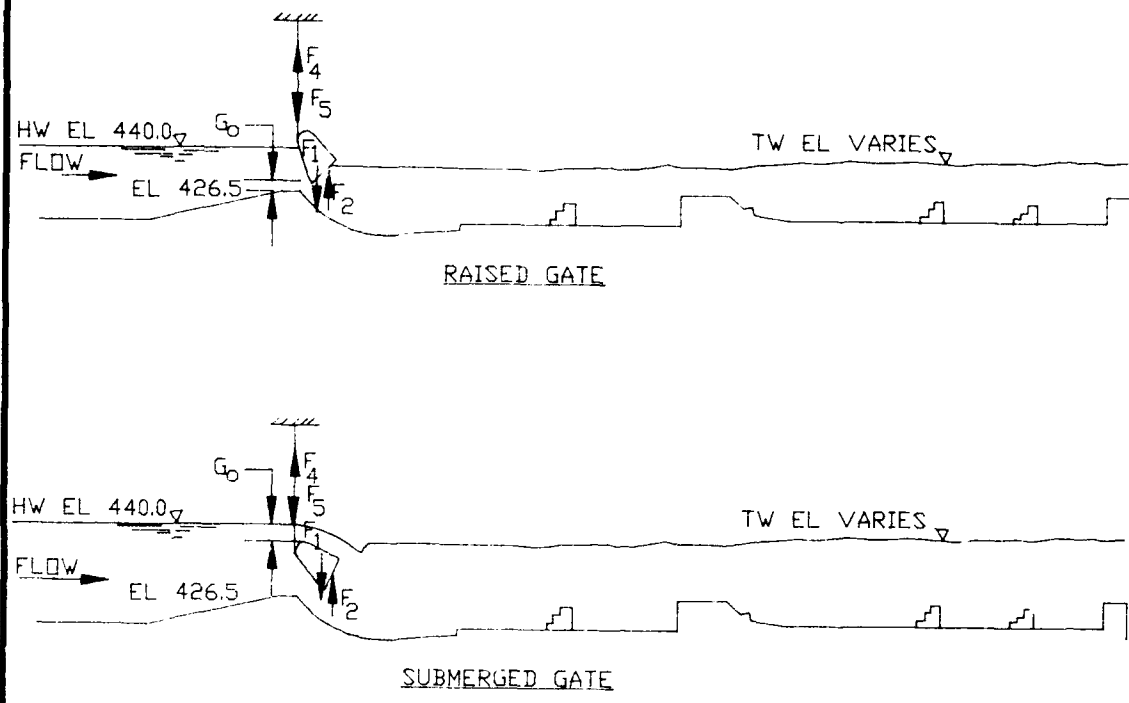

F_1 = Dry weight of gate supported by cables, lb

F_2 = Tailwater displaced by gate, lb

F_3 = $(F_1 - F_2)$, submerged weight of gate supported by cables, lb

F_4 = Measured loads during tests, lb

F_5 = Flow-induced loads on cables, $F_4 - F_3$, lb

HW EL = Headwater elevation, 440.0 ft NGVD

TW EL = Tailwater elevation, ft NGVD (varies)

DEFINITION SKETCH
OF FORCE MEASUREMENTS

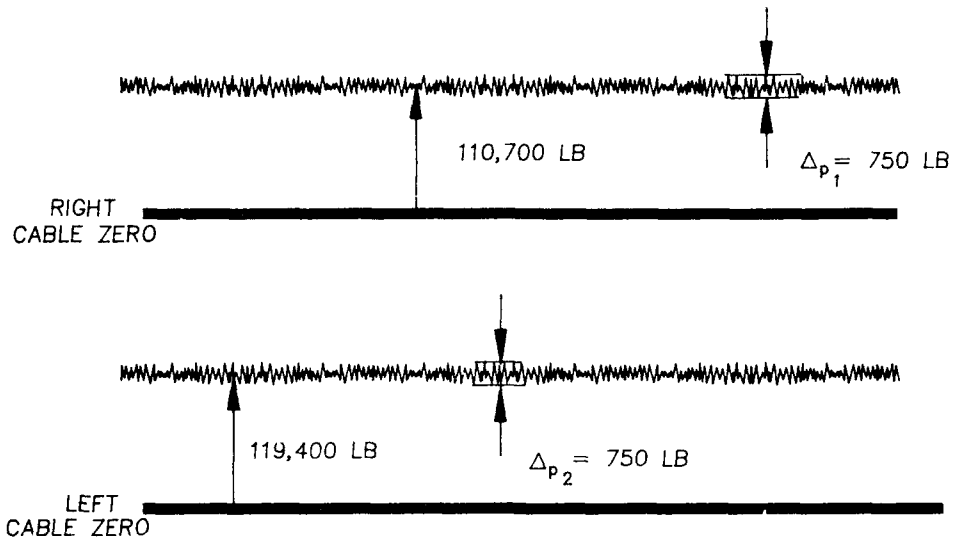

SAMPLE OSCILLOGRAPH RECORD

SAMPLE CALCULATION

GIVEN: GATE SUBMERGENCE = 1 FT, TW EL 429

$$F_1 = 175,200 \text{ LB}$$

$$F_2 = 5,700 \text{ LB}$$

$$F_3 = F_1 - F_2$$

$$F_3 = 175,200 - 5,700$$

$$F_3 = 169,500 \text{ LB}$$

$$F_4 = 230,100 \text{ LB}$$

$$F_{5MAX} = F_4 - F_3$$

$$F_{5MAX} = 230,100 - 169,500$$

$$F_{5MAX} = 60,600 \text{ LB}$$

$$F_{5MIN} = F_{5MAX} - \Delta_p$$

$$F_{5MIN} = 60,600 - 1,500$$

$$F_{5MIN} = 59,100 \text{ LB}$$

$$\Delta_p = \Delta_{p1} + \Delta_{p2}$$

$$\Delta_p = 750 + 750$$

$$\Delta_p = 1,500 \text{ LB}$$

$$f = 3.8 \text{ Hz}$$

WHERE F_{5MAX} = Maximum flow--induced loads on cables, lb

F_{5MIN} = Minimum flow--induced loads on cables, lb

Δ_p = Amplitude of load fluctuations, lb

f = Frequency of vibration

Hz = Hertz, cycles/sec

SAMPLE FORCE
CALCULATION
AND
OSCILLOGRAPH RECORD