

AD-A243 252



NAVAL POSTGRADUATE SCHOOL
Monterey, California

DTIC
ELECTE
DEC 10 1991
S C D



THESIS

MODELING CONVERGENCE ZONE GAIN
ON MS-DOS BASED PERSONAL COMPUTERS

by

Alan K. Jenkins

December 1991

Thesis Advisor:

A.B. Coppens

Approved for public release; distribution is unlimited.

91-17298



91 12 0 053

UNCLASSIFIED

SECURITY CLASSIFICATION OF THIS PAGE

REPORT DOCUMENTATION PAGE				Form Approved OMB No 0704-0188	
1a REPORT SECURITY CLASSIFICATION UNCLASSIFIED		1b RESTRICTIVE MARKINGS NONE			
2a SECURITY CLASSIFICATION AUTHORITY N/A		3 DISTRIBUTION/AVAILABILITY OF REPORT Approved for public release; distribution unlimited.			
2b DECLASSIFICATION/DOWNGRADING SCHEDULE					
4 PERFORMING ORGANIZATION REPORT NUMBER(S) Naval Postgraduate School		5 MONITORING ORGANIZATION REPORT NUMBER(S) N/A			
6a. NAME OF PERFORMING ORGANIZATION Naval Postgraduate School	6b OFFICE SYMBOL (If applicable) Code 3A	7a. NAME OF MONITORING ORGANIZATION Naval Postgraduate School			
6c. ADDRESS (City, State, and ZIP Code) Monterey, CA 93943-5000		7b ADDRESS (City, State, and ZIP Code)			
8a. NAME OF FUNDING/SPONSORING ORGANIZATION N/A	8b OFFICE SYMBOL (If applicable)	9 PROCUREMENT INSTRUMENT IDENTIFICATION NUMBER			
8c. ADDRESS (City, State, and ZIP Code)		10 SOURCE OF FUNDING NUMBERS			
		PROGRAM ELEMENT NO	PROJECT NO	TASK NO	WORK UNIT ACCESSION NO
11 TITLE (Include Security Classification) Modeling Convergence Zone Gain on MS-DOS Based Personal Computers					
12 PERSONAL AUTHOR(S) Jenkins, Alan K.					
13a TYPE OF REPORT Master's Thesis	13b TIME COVERED FROM _____ TO _____	14 DATE OF REPORT (Year, Month, Day) December 1991		15 PAGE COUNT 84	
16 SUPPLEMENTARY NOTATION The views expressed in this thesis are those of the author and do not reflect the official policy or position of the Department of Defense or the U.S. Government					
17 COSATI CODES			18 SUBJECT TERMS (Continue on reverse if necessary and identify by block number)		
FIELD	GROUP	SUB-GROUP	Convergence Zone, CZ, Convergence Zone Gain, Ray Tracing, Ray Theory, Acoustic Modeling		
19 ABSTRACT (Continue on reverse if necessary and identify by block number) The models for determining convergence zone Gain (G) were developed using a linearized Sound Speed Profile (SSP) and applying ray tracing theory. The SSP was divided into three cases; bilinear, bilinear with isospeed layer, and bilinear with mixed layer. Two analytical solutions were developed using Taylor series and binomial series expansions to determine G, one for the bilinear and bilinear with isospeed layer, and the other for the bilinear with a mixed layer. The solutions for G are exclusively a function of the SSP gradients. Each solution was compared to the solutions from ray tracing and the solutions from the Integrated Carrier ASW Prediction System (ICAPS) (which runs on mainframe computers and requires more data in addition to the SSP). When the SSP's were not too unusual, the solutions for G were fairly close when compared to ray tracing and ICAPS.					
20 DISTRIBUTION/AVAILABILITY OF ABSTRACT <input checked="" type="checkbox"/> UNCLASSIFIED/UNLIMITED <input type="checkbox"/> SAME AS RPT <input type="checkbox"/> DTIC USERS			21 ABSTRACT SECURITY CLASSIFICATION UNCLASSIFIED		
22a NAME OF RESPONSIBLE INDIVIDUAL A. B. Coppens		22b TELEPHONE (Include Area Code) 408-646-2941		22c OFFICE SYMBOL PH/Cz	

Approved for public release; distribution is unlimited.

Modeling Convergence Zone Gain
on MS-DOS Based Computers

by

Alan K. Jenkins
B.S.E.E., Auburn University

Submitted in partial fulfillment
of the requirements for the degree of

MASTER OF SCIENCE IN APPLIED SCIENCE

from the

NAVAL POSTGRADUATE SCHOOL

December 1991

Author:

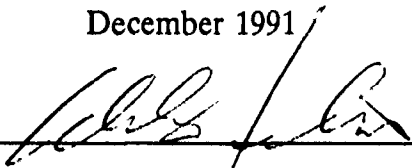

Alan K. Jenkins

Approved by:



A.B. Coppens, Thesis Advisor

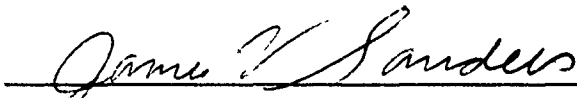

J.V. Sanders, Co Advisor

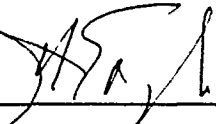

J.N. Eagle, Chairman
Antisubmarine Warfare Academic Group

ABSTRACT

The models for determining convergence zone Gain (G) were developed using a linearized Sound Speed Profile (SSP) and applying ray tracing theory. The SSP was divided into three cases; bilinear, bilinear with isospeed layer, and bilinear with mixed layer. Two analytical solutions were developed using Taylor series and binomial series expansions to determine G, one for the bilinear and bilinear with isospeed layer, and the other for the bilinear with a mixed layer. The solutions for G are exclusively a function of the SSP gradients. Each solution was compared to the solutions from ray tracing and the solutions from the Integrated Carrier ASW Prediction System (ICAPS) (which runs on mainframe computers and requires more data in addition to the SSP). When the SSP's were not too unusual, the solutions for G were fairly close when compared to ray tracing and ICAPS.

Accession For	
NTIS GRA&I	<input checked="" type="checkbox"/>
ERIC TAB	<input type="checkbox"/>
Unannounced	<input type="checkbox"/>
Justification	
By _____	
Distribution/	
Availability Codes	
Dist	Avail and/or Special
A-1	



TABLE OF CONTENTS

I. INTRODUCTION	1
A. BACKGROUND	1
B. DESIRABLE QUALITIES FOR COMPUTER MODELS	2
C. PURPOSE	2
II. CZ RAY TRACING THEORY	3
A. WHY RAY TRACING?	3
B. CONVERGENCE ZONES	3
1. Range to Outer Edge of the Reswept Zone	5
2. Range to Inner Edge of the Reswept Zone	7
3. Range to the CZ	7
4. Width of the Convergence Zone	7
5. Convergence Zone Gain	7
III. MODEL DEVELOPMENT	12
A. GENERAL	12
B. BILINEAR SSP	13
1. Range to the Outer Edge of the CZ	13

2.	Range to the Inner Edge of the CZ	13
3.	CZ Gain	19
C.	BILINEAR WITH ISOSPEED LAYER SSP	20
1.	Range to the Outer Edge of the CZ	20
2.	Range to the Inner Edge of the CZ	20
3.	Width of CZ and CZ Gain	23
D.	BILINEAR WITH MIXED LAYER SSP	23
1.	Range to Outer Edge of the CZ	23
2.	Range to the Inner Edge of the CZ	23
3.	CZ Gain	27
E.	COMPUTER MODELS	27
IV.	RESULTS AND VALIDATION	32
A.	GENERAL	32
B.	BILINEAR SSP	34
C.	BILINEAR WITH ISOSPEED LAYER SSP	36
D.	BILINEAR WITH A MIXED LAYER SSP	37
V.	CONCLUSIONS	39
A.	MODEL LIMITATIONS	39
B.	MODEL PRACTICALITY	40
1.	Data Requirements	40

2. Output	41
3. Speed	41
4. Program Foundation	41
C. COMPARISON TO EARLIER MODELS	41
D. GENERAL	42
LIST OF REFERENCES	43
APPENDIX A - SERIES EXPANSIONS	44
A. TRIGONOMETRIC SERIES EXPANSIONS	44
1. Cosine θ	44
2. Tangent θ	44
B. BINOMIAL SERIES EXPANSION	44
APPENDIX B	45
APPENDIX C	48
APPENDIX D	52
APPENDIX E	56

APPENDIX F	70
BIBLIOGRAPHY	72
INITIAL DISTRIBUTION LIST	73

LIST OF FIGURES

Figure 1 - Horizontal Distances	4
Figure 2 - Bilinear profile sound rays of interest	6
Figure 3 - Reference Area Diagram for CZ Gain	8
Figure 4 - CZ reference area (cross section)	9
Figure 5 - Reference diagram for subscript conventions.	12
Figure 6 - Bilinear, Bilinear with Isospeed Layer, and Bilinear with Mixed Layer SSP's	13
Figure 7 - CZGAIN Display Depiction	31

ACKNOWLEDGEMENT

I would like to thank the personnel in IX03 for their continued support, not only in helping to improve this final product but also in their outstanding teamwork both inside and outside the classroom.

I would also like to thank my advisors for their time spent in helping me to recognize what was too small to include and what was not too small to discard (check the development section). Additionally, they were invaluable in helping me express the results of my research.

I. INTRODUCTION

A. BACKGROUND

Convergence zone (CZ) parameters such as range to CZ, CZ width, and CZ gain are typically obtained using large mainframe computers implementing complex software programs. The U.S. Navy utilizes the Fleet Numerical Oceanographic Center (FNOC), Monterey, California, to predict these parameters. The frequencies of interest, source and receiver depths, Sound Speed Profile (SSP), wave height, time of day, date, and geographic location are used in obtaining the CZ parameters.

In addition to FNOC, the fleet may use the Integrated Carrier ASW Prediction System (ICAPS). ICAPS was designed for use onboard ships. It consists of several databases of environmental data and can provide the user with a cornucopia of acoustic parameters.

Both of these methods require the use of mainframe or "mainframe-like" computers. Several programs for hand-held and desktop calculators have been written in attempts to obtain quick estimates of CZ parameters based on current bathythermograph (BT) data.¹ However, none of the calculator programs is usable on IBM-based disk operating system (MS-DOS) running on personal computers (PC's). With the advent of notebook PC's, and with the palmtop PC on the horizon, a definite need exists for models which will run on an MS-DOS based computer.

¹ See the Bibliography for further information.

B. DESIRABLE QUALITIES FOR COMPUTER MODELS

The following is a list of general guidelines for computer models

[Ref. 1:pp.13,14].

- A minimum amount of data should be required to run the program. Additionally, any data used should not be entered more than once.
- Output should give range to the inner edge of the CZ, width of the CZ, and CZ gain. The output should also give a repeat of the inputs.
- The program should run quickly.
- The program should be based on acoustic theory rather than general thumb rules and agree with mainframe prediction models.

C. PURPOSE

The purpose of this study is to provide a MS-DOS based program following the general guideline for desirable qualities for PC models listed above. The model will be based on ray tracing *vice* ray mode theory.

II. CZ RAY TRACING THEORY

A. WHY RAY TRACING?

To simplify the mathematics and programming involved, ray tracing theory was selected over normal mode theory. Ray tracing provides an easy visualization of how sound energy propagates through the ocean, even with complicated SSP and bottom structures. A sound ray can be traced from the source to the desired range without any need for complex calculations. As diffraction of the sound energy becomes more noticeable at lower frequencies, and as ray tracing theory does not consider diffraction, ray tracing becomes more valid as the frequency increases.

Normal mode theory gives a complete description of the sound field. However, it cannot easily handle real boundary conditions. All frequencies can be used but complexity increases with the frequency. [Ref. 2:p.122]

B. CONVERGENCE ZONES

Imagine the sound rays projected from a source at the surface. Some of these rays may get trapped in a surface duct or interact with the bottom. Other rays may be able to penetrate below the SOFAR axis, get refracted upward, and reacquire the surface. Starting from the horizontal and increasing the angle of depression, the first ray which crosses the sound axis and reacquires the surface does so at a range equal to r_{outer} . As the depression angle increases further, the range at which the ray

resurfaces first decreases to a minimum, then increases, resweeping back beyond r_{outer} . For an omnidirectional source the reswept area forms an annulus about the source and is acoustically brighter than the surrounding areas. When this brightened area is compared to a reference area at 1 meter from the source, the CZ gain can be calculated.

Figure 1 illustrates the horizontal distance a ray travels in a linear sound speed gradient g .

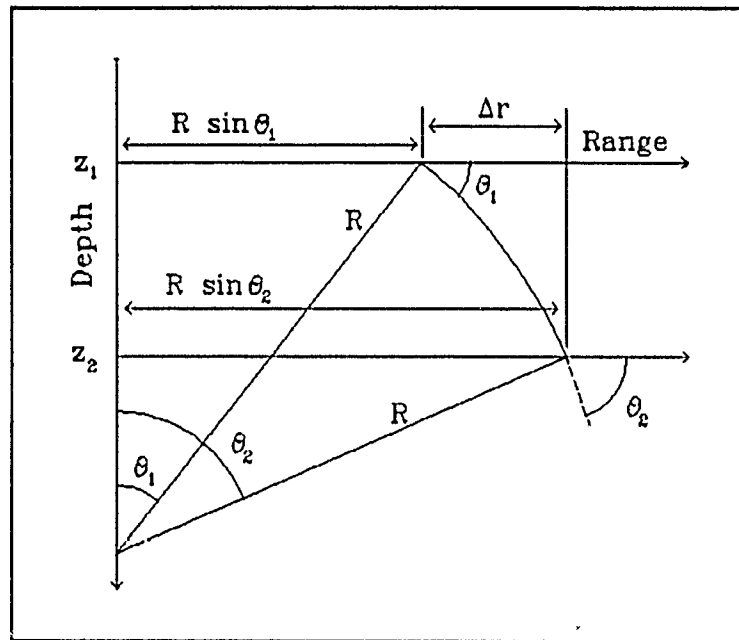

Figure 1 - Horizontal Distances

For the case shown, the sound speed, c , is expressed as a function of depth by $c(z) = c_0(1+gz)$. At depth z_1 , the sound speed is c_1 , and the downward angle of the ray is θ_1 . At depth z_2 , the sound speed is c_2 , and the downward angle of the ray is θ_2 . Snell's law states that $c/(g \cos\theta)$ is constant along the ray path.

The gradient is given by

$$g = \frac{c_1 - c_2}{z_2 - z_1}$$

and radius of curvature R of the ray is

$$R = \frac{c}{g \cos \theta} = \frac{c_1}{g \cos \theta_1} = \frac{c_2}{g \cos \theta_2}$$

The horizontal distance Δr the ray travels and the change in depth Δz are given geometrically by

$$\Delta r = r_2 - r_1 = R(\sin \theta_2 - \sin \theta_1)$$

$$\Delta z = z_2 - z_1 = R(\cos \theta_1 - \cos \theta_2)$$

The ordering of subscripts in the above equations result from the convention of measuring an angle of elevation positive upwards but depth is defined as positive downward.

1. Range to Outer Edge of the Reswept Zone

The ray with initial depression angle of θ_{out} defines the range, r_{outer} , to the outer edge of the reswept zone. At this range, the acoustic energy experiences a sharp drop in intensity. For the bilinear profile illustrated in Fig. 2, $\theta_{\text{out}} = 0^\circ$.

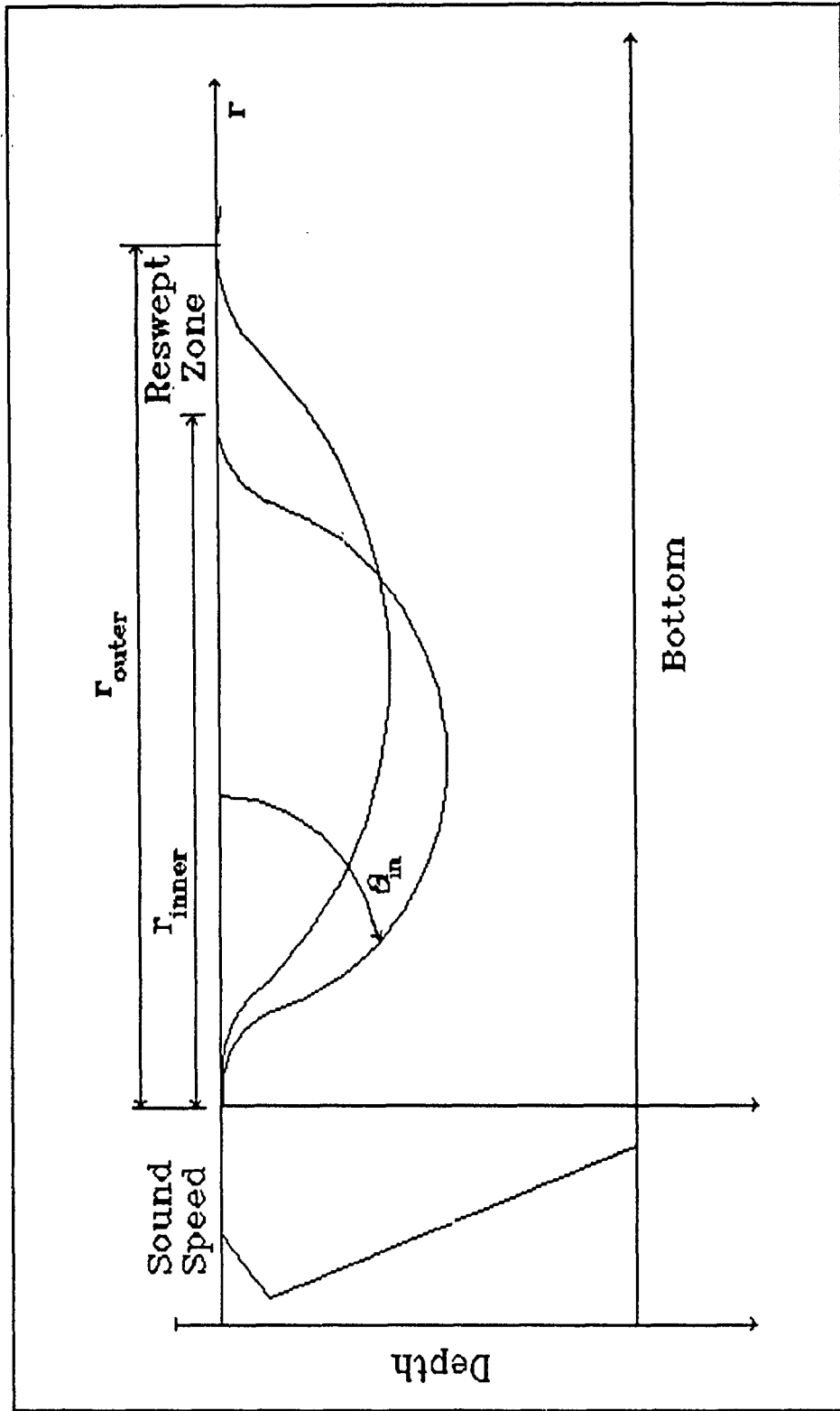

Figure 2 - Bilinear profile sound rays of interest

2. Range to Inner Edge of the Reswept Zone

The ray with a depression angle of θ_{in} defines the range, r_{inner} to the inner edge of the reswept zone. Because of the strong convergence of neighboring rays, with the formation of a caustic (where sound rays cross each other) at the inner edge of the CZ, there is a strong enhancement of the intensity. Additionally, ray theory does not provide a suitable description of this part of the problem.

3. Range to the CZ

The range to the CZ zone will be defined as the range r_{outer} [Ref. 1 :p.51]. For the remainder of the discussion, the reswept zone will be considered the CZ, and bottom interactions will not be considered. This follows a consistent course as developed in earlier models which have also ignored bottom interactions [Ref.1:p.51].

4. Width of the Convergence Zone

The CZ width, Δr_{CZ} , is the distance from the outer edge of the reswept zone to the inner edge of the reswept zone. The width of the CZ is thus taken to be

$$\Delta r_{CZ} = r_{outer} - r_{inner} \quad (1)$$

5. Convergence Zone Gain

The general definition for Transmission Loss (TL) is

$$TL = 10 \log \left(\frac{I(1)}{I(r)} \right)$$

where $I(1)$ is the intensity of the sound beam at $r = 1$ meter, and $I(r)$ is the intensity of the sound beam at r meters from the source.

By conservation of energy, the following relationships for the intensities and areas through which the rays pass normally can be made.

$$I(1)A(1) = I(r)A(r)$$

where $A(1)$ is the cross-sectional surface area for the sound beam as illustrated in Fig. 3, and $A(r)$ is the cross-sectional area for the beam at r . The geometric TL is now

$$TL_g = 10 \log \left(\frac{A(r)}{A(1)} \right)$$

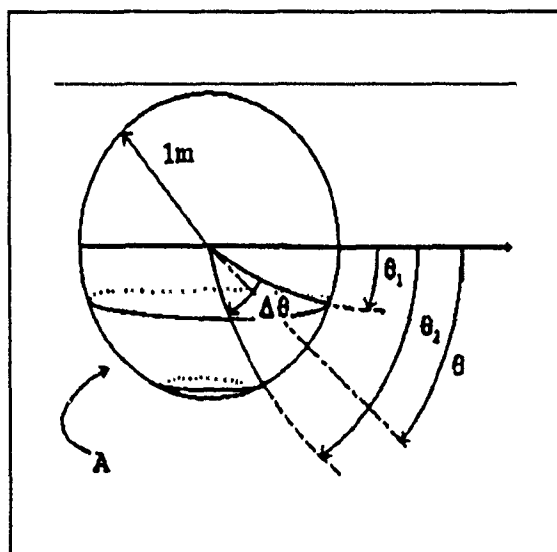

Figure 3 - Reference Area Diagram for CZ Gain

The area $A(1)$ is

$$A(1) = 2\pi \Delta\theta \cos\theta_{in}$$

Figure 4 pictures a cross sectional view of the area contained by the CZ. The intensity will be assumed to be uniform over this area. The area normal to the arriving rays of the CZ annulus [Ref. 1:p.62] is

$$A(r_{inner}) = 2\pi r_{inner} h$$

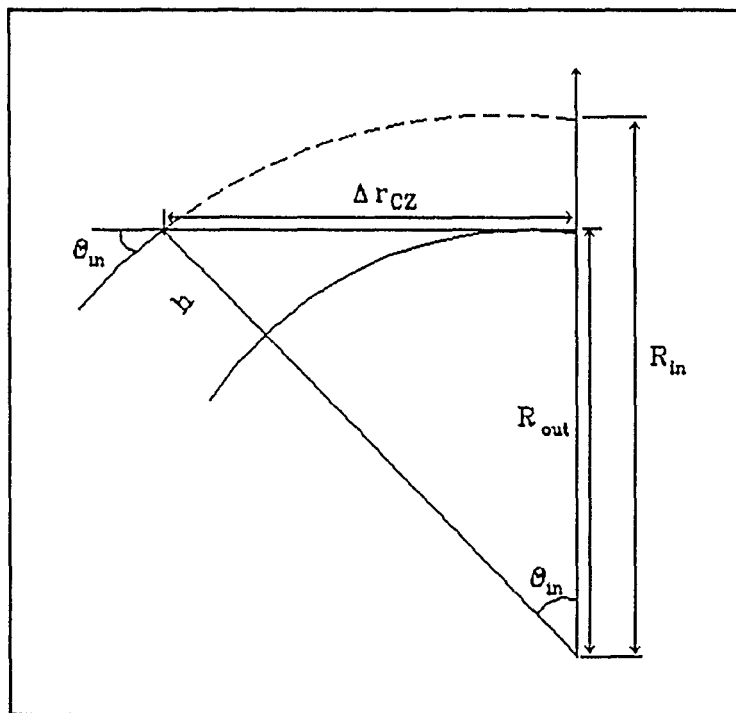

Figure 4 - CZ reference area (cross section)

TL_g becomes,

$$TL_g = \frac{2\pi \Delta\theta \cos\theta_{in}}{2\pi r_{inner} h}$$

$$\frac{\Delta r_{CZ}}{R_{out}} = \tan\theta_{in}$$

$$\frac{\Delta r_{CZ}}{R_{in}} = \sin\theta_{in}$$

$$h = \frac{\Delta r_{CZ}}{\sin\theta_{in}} (1 - \cos\theta_{in})$$

When the small angle approximation of $\Delta\theta = \theta_{in} \ll 1$ is substituted, and

$$A(1) \doteq 2\pi\theta_{in}$$

$$A(r_{inner}) \doteq \pi r_{inner} \Delta r_{CZ} \theta_{in}$$

TL_g is now

$$TL_g = 20 \log r_{inner} + 10 \log \left(\frac{2}{\Delta r_{CZ} \cdot r_{inner}} \right)$$

CZ Gain (G) is the difference between the TL_g from spherical spreading [20log(r)] and what is actually observed for the geometrical spreading loss. (There are two definitions for G. The first definition includes additional losses such as absorption in G, and the second definition considers absorptive losses separately [Ref. 3:p.408] [Ref. 4:p.7.1]. As a frequency independent model will be developed, the second definition for G will be used.)

So G is now

$$G = 10 \log \frac{2r_{inner}}{\Delta r_{CZ}} \quad (2)$$

In real ocean conditions, the intensity within the CZ has an appearance similar to a Rayleigh distribution. The intensity rises sharply from zero at r_{inner} and gradually declines to zero at r_{outer} . Because the exact distribution is unknown and a single number is desired for the CZ gain, G will be assumed to be uniformly distributed over Δr_{CZ} , and (2) will give the average value of G. Simplifying G to an average value follows earlier work done in similar models [Ref.1:p.40].

III. MODEL DEVELOPMENT

A. GENERAL

Several approximations are used throughout the development to reduce equations to a manageable and easily understandable form. The approximations used are contained in Appendix A.

The convention used when labeling angles, sound speeds, and radii of curvature is the subscript is always tied to the gradient. As illustrated in Fig. 5, for the deep gradient g_1 , the ray entering this region at a depth z_1 has a radius of curvature R_1 and an initial angle entering this region of θ_1 .

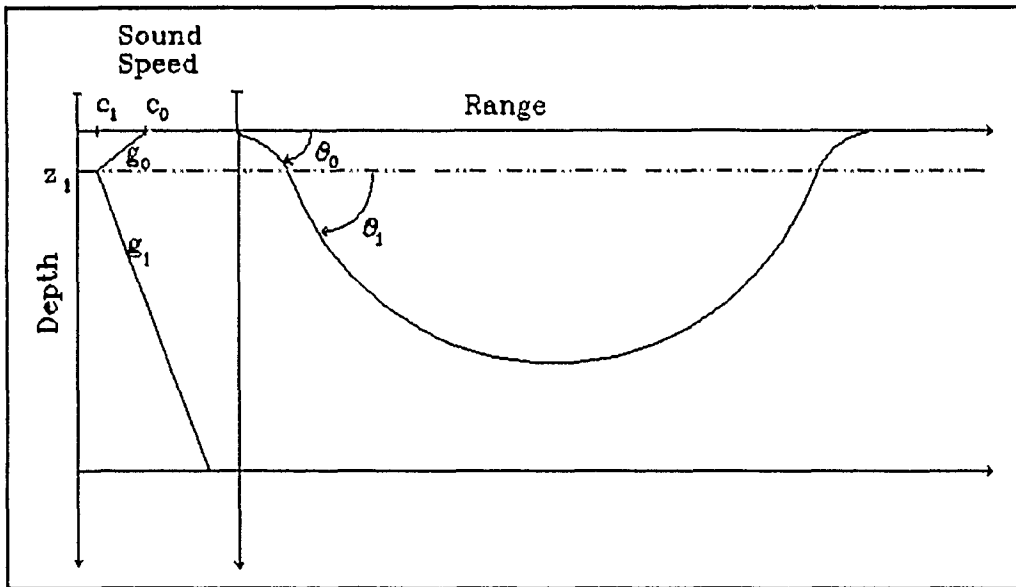

Figure 5 - Reference diagram for subscript conventions.

The three SSP's which will be examined are bilinear, bilinear with isospeed layer, and bilinear with mixed layer. Figure 6 illustrates the three profile types.

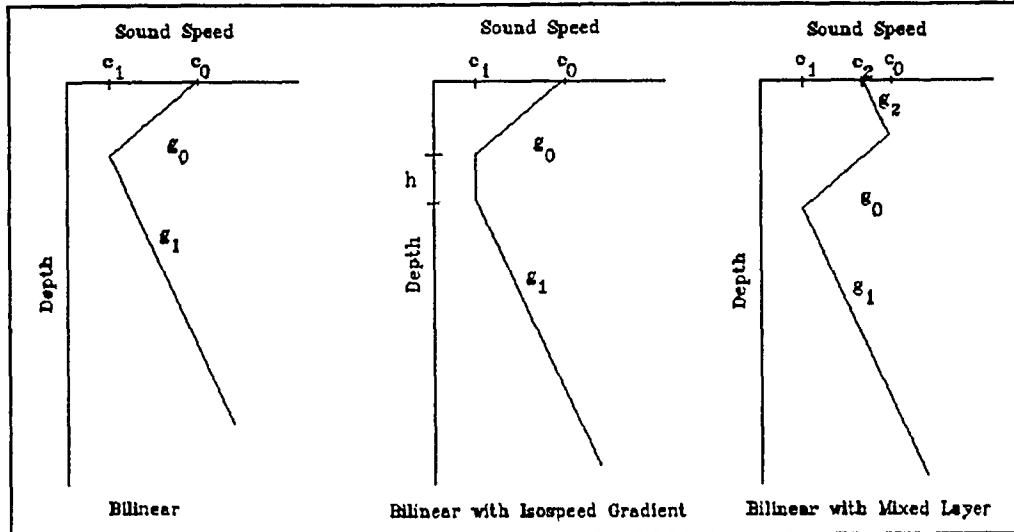

Figure 6 - Bilinear, Bilinear with Isospeed Layer, and Bilinear with Mixed Layer SSP's

B. BILINEAR SSP

1. Range to the Outer Edge of the CZ

The ray reacquiring the surface at r_{outer} has an initial depression angle $\theta_{\text{out}} = 0^\circ$.

2. Range to the Inner Edge of the CZ

Examination of Fig. 5 shows that the range from the source (at the surface) to where a ray with a depression angle θ_0 reacquires the surface can be expressed as:

$$r = 2[R_0(\sin\theta_1 - \sin\theta_0) + R_1\sin\theta_1] \quad (3)$$

Using Snell's Law:

$$\frac{c_0}{\cos\theta_0} = \frac{c_1}{\cos\theta_1}$$

The radius of curvature for the lower layer R_1 can be expressed in terms of the radius of curvature for the upper layer R_0 ,

$$R_1 = \frac{g_0}{g_1} R_0$$

and when R_1 is eliminated from the range equation (3),

$$r = 2R_0 \left[\left(1 + \frac{g_0}{g_1} \right) \sin\theta_1 - \sin\theta_0 \right]$$

Again using Snell's Law, a relationship can be found for the θ_0 and θ_1 ,

$$\sin\theta_1 = \sqrt{1 - \cos^2\theta_0}$$

$$\sin \theta_1 = \sqrt{1 - \frac{c_1^2}{c_0^2} \cos^2 \theta_0}$$

Simplifying the range equation to

$$r = 2R_0 \left[\left(1 + \frac{g_0}{g_1} \right) \sqrt{1 - \frac{c_1^2}{c_0^2} \cos^2 \theta_0} - \sin \theta_0 \right]$$

$$r = 2 \frac{c_0}{g_0} \left[\left(1 + \frac{g_0}{g_1} \right) \sqrt{\frac{1}{\cos^2 \theta_0} - \frac{c_1^2}{c_0^2}} - \tan \theta_0 \right] \quad (4)$$

Manipulation of (the above equation) to obtain r_{inner} is cumbersome but direct. Differentiating r with respect to θ_0 and imposing

$$\left. \frac{dr}{d\theta_0} \right|_{\theta_0 = \theta_{\text{in}}} = 0$$

enables θ_{in} to be solved analytically and directly input into (3) to solve for r_{inner} .

Without further simplification the solution for θ_0 yields a difficult transcendental equation for θ_{in} . However, because θ_0 is generally significantly less

than 20° (0.3491 radian) the trigonometric functions can be replaced by Taylor series expansions and terms of third and higher order can be discarded. By replacing the trigonometric functions, (4) simplifies to

$$r = 2 \frac{c_0}{g_0} \left[\left(1 + \frac{g_0}{g_1} \right) \sqrt{\frac{1}{\left(1 - \frac{1}{2} \theta_0^2 \right)^2} - \frac{c_1^2}{c_0^2}} - \theta_0 \right]$$

Further manipulation of the range equation using the binomial expansions in Appendix A yields

$$r = 2 \frac{c_0}{g_0} \left[\left(1 + \frac{g_0}{g_1} \right) \sqrt{1 + \theta_0^2 - \frac{c_1^2}{c_0^2}} - \theta_0 \right] \quad (5)$$

Convenient parameters can be defined:

$$\gamma \equiv \frac{c_1}{c_0} \quad (6)$$

$$\alpha^2 \equiv 1 - \gamma^2 \quad (7)$$

and,

$$\Gamma \equiv 1 + \frac{g_0}{g_1} \quad (8)$$

The final form of the range equation

$$r = 2 \frac{c_0}{g_0} \left[\Gamma \sqrt{1 - \gamma^2 + \theta_0^2} - \theta_0 \right] \quad (9)$$

Now, differentiation yields

$$\frac{dr}{d\theta_0} = 2 \frac{c_0}{g_0} \left[\frac{\theta_0 \Gamma}{\sqrt{1 - \gamma^2 + \theta_0^2}} - 1 \right]$$

Note that for $\theta_0 = 0$, $dr/d\theta_0$ is negative, so the range is decreasing with an increasing θ_0 . The minimum range, r_{inner} is found by determining the value of $\theta_0 = \theta_{in}$ for which $dr/d\theta_0$ vanishes.

$$\left. \frac{dr}{d\theta_0} \right|_{\theta_0 = \theta_{in}} = 2 \frac{c_0}{g_0} \left[\frac{\theta_{in} \Gamma}{\sqrt{1 - \gamma^2 + \theta_{in}^2}} - 1 \right] = 0$$

Manipulating this equation gives

$$1 = \frac{\theta_{in} \Gamma}{\sqrt{1 - \gamma^2 + \theta_{in}^2}}$$

$$\theta_{in}^2(\Gamma^2 - 1) - (\gamma^2 - 1) = 0$$

and finally,

$$\theta_{in} = \sqrt{\frac{1 - \gamma^2}{\Gamma^2 - 1}} \quad (10)$$

Substituting into (9) yields an r_{inner} of

$$r_{inner} = 2 \frac{c_0}{g_0} \left[\Gamma \sqrt{\alpha^2 + \frac{\alpha^2}{\Gamma^2 - 1}} - \sqrt{\frac{\alpha^2}{\Gamma^2 - 1}} \right]$$

Reducing we have

$$r_{inner} = 2 \frac{c_0}{g_0} \sqrt{\frac{\alpha^2}{\Gamma^2 - 1}} [\Gamma^2 - 1]$$

and finally,

$$r_{\text{inner}} = 2 \frac{c_0}{g_0} \sqrt{\alpha^2 (\Gamma^2 - 1)} \quad (11)$$

3. CZ Gain

With substitution of r_{inner} and r_{outer} into (1), the CZ width can be expressed as

$$\Delta r_{\text{CZ}} = 2 \frac{c_0}{g_0} \left[\Gamma \sqrt{\alpha^2} - \sqrt{\alpha^2 (\Gamma^2 - 1)} \right]$$

$$\Delta r_{\text{CZ}} = 2 \frac{c_0}{g_0} \sqrt{\alpha^2} \left[\Gamma - \sqrt{\Gamma^2 - 1} \right] \quad (12)$$

Substitution into the CZ gain, equation (2), gives

$$G = 10 \log \left(\frac{2 \sqrt{\Gamma^2 - 1}}{\Gamma - \sqrt{\Gamma^2 - 1}} \right) \quad (13)$$

Observe that G is only a function of the upper and lower gradients and the lack of dependence upon sound speed, depth (although these are implicitly contained in the gradients), and the ray departure angles.

C. BILINEAR WITH ISOSPEED LAYER SSP

1. Range to the Outer Edge of the CZ

As with the previous SSP, r_{outer} is determined by using an initial depression angle of $\theta_0 = 0^\circ$.

2. Range to the Inner Edge of the CZ

Adding an isospeed layer of thickness h to the bilinear SSP gives a new range equation

$$r = 2 \left[R_0 (\sin \theta_1 - \sin \theta_0) + h \cot \theta_1 + R_1 \sin \theta_1 \right] \quad (14)$$

Manipulation of the R's and trigonometric functions yields

$$\frac{r}{2} = \frac{c_0}{g_0} \left[\Gamma \sqrt{\frac{1}{\cos^2 \theta_0} - \gamma^2} - \tan \theta_0 \right] + \frac{\gamma h}{\sqrt{\frac{1}{\cos^2 \theta_0} - \gamma^2}}$$

Making use of series expansions from Appendix A,

$$\frac{r}{2} = \frac{c_0}{g_0} \left[\Gamma \sqrt{1 - \gamma^2 + \theta_0^2} - \theta_0 \right] + \frac{\gamma h}{\sqrt{1 - \gamma^2 + \theta_0^2}} \quad (15)$$

An additional definition which will prove to be useful is,

$$\epsilon = \frac{g_0 \gamma h}{c_0} \quad (16)$$

To get r_{inner} ,

$$\left. \frac{dr}{d\theta} \right|_{\theta_0 = \theta_{\text{in}}} = 0$$

Which gives the following equation,

$$0 = \frac{\Gamma \theta_{\text{in}}}{\sqrt{\alpha^2 - \theta_{\text{in}}^2}} - 1 - \frac{\epsilon \theta_{\text{in}}}{(\alpha^2 - \theta_{\text{in}}^2)^{\frac{3}{2}}}$$

and by factoring out the radicals,

$$\alpha^2 + \theta_{\text{in}}^2 = \Gamma^2 \theta_{\text{in}}^2 - \frac{2 \epsilon \Gamma \theta_{\text{in}}^2}{\alpha^2 + \theta_{\text{in}}^2} + \frac{\epsilon^2 \theta_{\text{in}}^2}{(\alpha^2 + \theta_{\text{in}}^2)^2}$$

and finally,

$$0 = \theta_{\text{in}}^6 [\Gamma^2 - 1] + \theta_{\text{in}}^4 \alpha^2 [2\Gamma^2 - 3 + 2\epsilon \Gamma] + \theta_{\text{in}}^2 \alpha^4 \left[\Gamma^2 - 3 + \frac{2\epsilon \Gamma}{\alpha^2} + \frac{\epsilon^2}{\alpha^4} \right] - \alpha^6 \quad (17)$$

Note that this equation is cubic in θ_{in}^2 whereas the bilinear case the corresponding equation was linear in θ_{in} . Additionally, as h approaches zero, this reduces to equation (10). To reduce this cubic equation to a more manageable form, the relative size of the coefficients for θ_{in} will be considered. Using historical data on SSP's from the Atlantic, Pacific, and Mediterranean the following can be related [Ref. 1:pp.30,67]:

$$\gamma < 1$$

$$\alpha < 1$$

$$g_0 < 1$$

$$0 < h < 250$$

$$c_0 \approx 1500$$

$$\text{Thus, } \epsilon < 1$$

Because ϵ is much less than 1, the ϵ^2 term will be discarded. By discarding this term, an equation which is quadratic with respect to θ_{in} results and can be expressed:

$$0 = \theta_{in}^4 [\Gamma^2 - 1] + \theta_{in}^2 \alpha^2 \left[\Gamma^2 - 2 - \frac{2\Gamma\epsilon}{\alpha^2} \right] - \alpha^4 \quad (18)$$

And finally,

$$\theta_{in} = \sqrt{\frac{\alpha^2}{2(\Gamma^2 - 1)}} \left[-\left(\Gamma^2 - 2 - \frac{2\epsilon\Gamma}{\alpha^2}\right) + \sqrt{\left(\Gamma^2 - 2 - \frac{2\epsilon\Gamma}{\alpha^2}\right)^2 + 4(\Gamma^2 - 1)} \right]^{\frac{1}{2}} \quad (19)$$

3. Width of CZ and CZ Gain

As expected, when ϵ (which is directly proportional to h) approaches zero this equation reduces to (10). Equation (19) does give the analytical solution to the isospeed case but is overly complicated when ϵ (thus h) is small (less than 250 m). Equation (10) will be used in the analysis as the solution for Δr_{CZ} and G .

D. BILINEAR WITH MIXED LAYER SSP

1. Range to Outer Edge of the CZ

With the addition of a mixed layer to the bilinear SSP, and remembering $\theta_0 = 0^\circ$, the initial depressions angle θ_2 for a source at the surface is expressed by,

$$\theta_2 = \arccos\left(\frac{c_2}{c_0}\right)$$

2. Range to the Inner Edge of the CZ

Figure 6 illustrates the SSP with the addition of a mixed layer. The range equation is now

$$r = 2R_0 \left[\left(1 + \frac{g_0}{g_1} \right) \sin \theta_1 - \sin \theta_0 + \frac{g_0}{g_2} (\sin \theta_2 - \sin \theta_0) \right] \quad (20)$$

Using the following definitions

$$H = 1 + \frac{g_0}{g_2} \quad (21)$$

$$\eta = \frac{c_2}{c_0} \quad (22)$$

$$\beta^2 = 1 - \eta^2 \quad (23)$$

results in the range equation becoming

$$r = 2R_0 \left[\Gamma \sin \theta_1 - H \sin \theta_0 + \frac{g_0}{g_2} \sin \theta_2 \right] \quad (24)$$

$$r = 2 \frac{c_0}{g_0} \left[\Gamma \sqrt{1 - \gamma^2 + \theta_0^2} - H \theta_0 + \frac{g_0}{g_2} \sqrt{1 - \eta^2 + \theta_0^2} \right] \quad (25)$$

(25) should reduce to (9) when c_2 is equal to c_0 , and g_2 is equal to g_1 . Using these conditions, (25) does reduce to (9) and consequently can be solved by use of (10).

Again, finding the angle, $\theta_0 = \theta_{in}$ at which $r = r_{inner}$,

$$0 = \frac{\Gamma \theta_{in}}{\sqrt{1 - \gamma^2 + \theta_{in}^2}} - H + \frac{g_0}{g_2} \frac{\theta_{in}}{\sqrt{1 - \eta^2 + \theta_{in}^2}}$$

so that

$$\theta_{in} = H \left[\frac{\Gamma}{\sqrt{1 - \gamma^2 + \theta_{in}^2}} + \frac{g_0}{g_2} \frac{1}{\sqrt{1 - \eta^2 + \theta_{in}^2}} \right]^{-1}$$

The solution for θ_{in} in this form is very formidable. However, if the surface sound speed is approximately equal to the sound axis speed, then $\alpha^2 \approx \beta^2$. θ_{in} can be expressed as

$$\theta_{in} = H \left[\frac{\Gamma}{\sqrt{\alpha^2 + \theta_{in}^2}} + \frac{g_0}{g_2} \frac{1}{\sqrt{\alpha^2 + \theta_{in}^2}} \right]^{-1}$$

$$\theta_{in} = H\alpha^2 \left[\left(\Gamma + \frac{g_0}{g_2} \right)^2 - H^2 \right]^{-\frac{1}{2}} \quad (26)$$

r_{inner} can be expressed by:

$$r_{inner} = 2 \frac{c_0}{g_0} \left[\Gamma \sqrt{\alpha^2 + \frac{H^2 \alpha^2}{\left(\left(\Gamma + \frac{g_0}{g_2} \right)^2 - H^2 \right)}} - \frac{H^2 \alpha}{\sqrt{\left(\Gamma + \frac{g_0}{g_2} \right)^2 - H^2}} + \frac{g_0}{g_2} \sqrt{\alpha^2 + \frac{H^2 \alpha^2}{\left(\left(\Gamma + \frac{g_0}{g_2} \right)^2 - H^2 \right)}} \right]$$

Which reduces to,

$$r_{inner} = 2 \frac{c_0}{g_0} \sqrt{(1 - \gamma^2) \left[\left(\Gamma + \frac{g_0}{g_2} \right)^2 - H^2 \right]} \quad (27)$$

Additionally, r_{outer} becomes:

$$r_{outer} = 2 \frac{c_0}{g_0} \sqrt{1 - \gamma^2} \left[\Gamma + \frac{g_0}{g_2} \right] \quad (28)$$

3. CZ Gain

The width of the CZ is now:

$$\Delta r_{CZ} = 2 \frac{c_0}{g_0} \sqrt{1 - \gamma^2} \left[\left(\Gamma + \frac{g_0}{g_2} \right) - \sqrt{\left(\Gamma + \frac{g_0}{g_2} \right)^2 - H^2} \right] \quad (29)$$

Substitution of r_{inner} and Δr_{CZ} into (2) yields,

$$G = 10 \log \left[\frac{2 \sqrt{\left(\Gamma + \frac{g_0}{g_2} \right)^2 - H^2}}{\left(\Gamma + \frac{g_0}{g_2} \right) - \sqrt{\left(\Gamma + \frac{g_0}{g_2} \right)^2 - H^2}} \right] \quad (30)$$

Note the similarity between (13) and (30) in that the only dependence is upon the gradients.

E. COMPUTER MODELS

In developing the computer programs to validate θ_{in} and G , the bilinear SSP was the basic case of interest with the mixed layer or isospeed layer being extensions. For this reason several conditions are placed upon the computer model inputs.

- c_2 is always less than c_0 .

- c_1 is always less than c_0 .
- h is never negative.
- The mixed layer is at least 1 m.
- The bottom gradient is 0.017 m/s/m.

Appendices B, C, and D contain the Fortran listings for the computer programs used to validate the equations for θ_{in} and G for the bilinear, bilinear with isospeed layer, and bilinear with mixed layer SSP's respectively. Combinations of sound speed, gradients, and thickness of isospeed layer were used where appropriate. But in order to evaluate the different cases, a range for the input values needed to be determined. These ranges were obtained from historical SSP's produced by ICAPS and contained in [Ref.1]. Profiles are from the Pacific (40N 140W), Atlantic (31N 69W), and Mediterranean (36N 18E) oceans for the months of February, May, August, and November [Ref. 1:pp.16-30]. Each estimate was evaluated using the following ranges of input where applicable:

- c_0 ranges from 1489 to 1541
- c_1 ranges from 1475 to 1525
- c_2 ranges from 1485 to 1525
- g_0 ranges from 0.01 to 0.246
- g_1 ranges from 0.003 to 0.017
- g_2 ranges from 0.01 to 0.06
- h ranges from 0 to 250

These sound speed, gradient, and h ranges were programmed into the validation programs, and equations (10)/(13) or (26)/(30), where appropriate, were evaluated against the solution obtained by ray tracing to determine θ_{in} , r_{inner} , Δr_{CZ} , and G. The input data range increment size varied depending on available storage space for the output files. As the number of variables increased the increment size was adjusted to give the smallest possible value while maintaining adequate space for file storage. A percent error for G was calculated using the following algorithm:

$$\% \text{ error} = 100 \times \frac{\text{estimate} - \text{ray tracing}}{\text{ray tracing}}$$

The historical data were input into ICAPS in calculating an average CZ gain. [Ref.1:pp.75] Appendix E contains the Fortran listing for the computer program, CZGAIN, used to compare the historical data from ICAPS to the results for G.

Figure 7 depicts a typical display for CZGAIN. The user inputs c_2 , c_0 , d_0 , c_1 , d_1 , h, and bottom depth. Once the user inputs the initial values, he may then manipulate those values with keyboard entries. Appendix F contains a user's guide for operation of CZGAIN. All of the data are color coded to the respective SSP (which labeled 1 and 2 for the black and white depiction). The unit dimensions for the Range vs. Theta are defined at the top, and the graph is scaled so that each curve starts at $\text{Theta}(0)$, $\text{Range}(0)$. As Theta (the depression angle at the source) is swept from $\text{Theta}(0)$ through $\text{Theta}(10)$ (0° to 15° as shown in Fig. 7) the range at which that ray resurfaces is plotted. Observe in Fig. 7 that the unit dimensions

remain the same for both curves, and each curve starts from the same point on the graph. The starting reference points (Range(0) and Theta(0)) are also color coded to their respective SSP's. Finally, the \bar{G} 's (also color coded) are presented. The bilinear approximation for r_{inner} and θ_{in} are given by Range(+) and Theta(+). Notice that as the SSP's (1) and (2) become more similar the Range vs. Theta curves approach each other, and the minimal effect from the isospeed thickness upon the Range vs. Theta curves.

The programs contain in Appendix B and C contain the basic algorithms and equations used for development of the analytical part of CZGAIN. The coding for the equations may more easily be extracted from any of these programs.

All of the programs were written using Microsoft's Fortran Version 5.0 on a Compaq Deskpro 386/33 Model 84 computer. The programs contained in Appendices B, C, and D have also run on the Naval Postgraduate School's mainframe after a few small modifications were made (e.g. the output files names were modified). A special software patch was obtained from Microsoft to allow the user to manipulate the data parameters without having to use the "Enter" key.

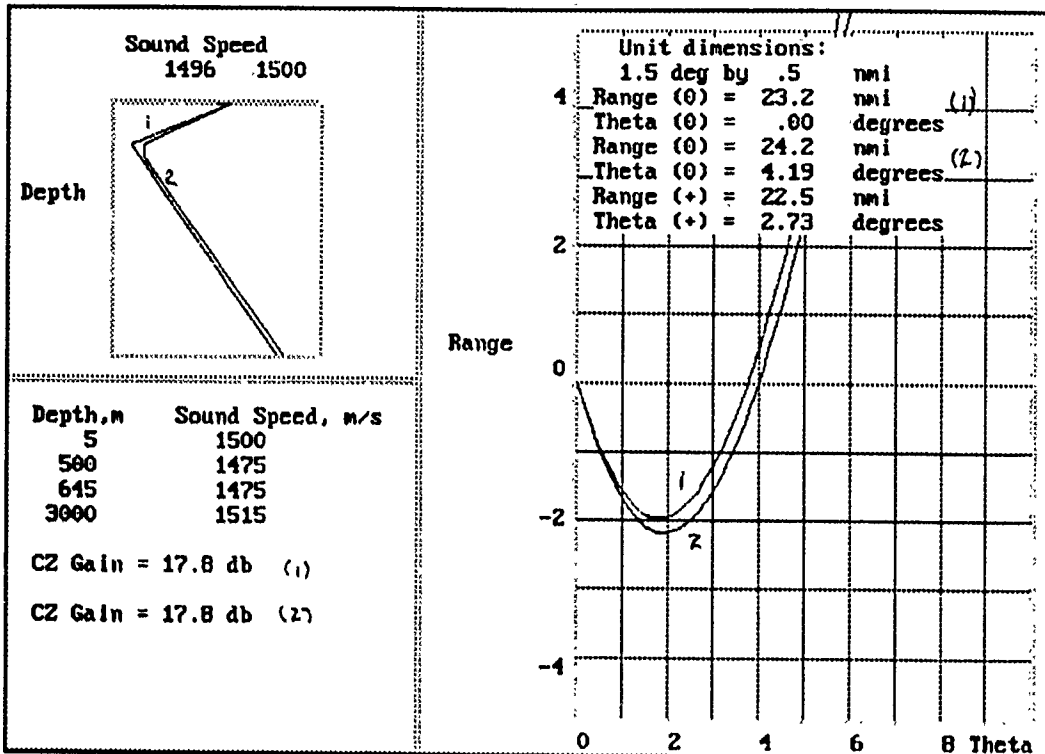

Figure 7 - CZGAIN Display Depiction

IV. RESULTS AND VALIDATION

A. GENERAL

While specific results will be presented later, overall the estimates for the CZ gain closely approximated the values obtained by ray tracing and from ICAPS.

If a difference of more than 3 dB existed between the estimate and the solution from ray tracing or ICAPS, the estimate was considered invalid. The 3 dB criterion was chosen because the numerous estimations to real ocean conditions made not only by the models developed here but also by ray tracing. A tighter requirement upon the models serves no purpose other than to require a higher degree of accuracy from the estimate, forcing additional complexity on the estimate.

The greatest potential for range errors (and thus errors in the gain calculations) occurs when the gradients are very small [Ref.1:p.66]. When the gradients are small an extremely high degree of accuracy is required for θ_0 to determine θ_{in} . The accuracy is required to diminish the effects of roundoff error and decrease the incrementation size for θ_0 . As c_1 and/or c_2 approaches c_0 the gradients approach zero (assuming that the respective sound speed depths remain constant). When c_0 and c_1 and/or c_0 and c_2 were less than about 2 m/s apart the model becomes invalid. Modifying the software to obtain the needed degree of accuracy for θ_0 was not considered to be necessary as this closeness of sound speeds is not a common

occurrence. During validation, the sound speeds were not permitted to be less than 2 m/s apart.

While the closeness of the sound speeds rarely occurs in the ocean, it does demonstrate a weakness in the model which would not have been discovered without model validation.

In comparing this model to the results from earlier models [Ref.1:p.75] it should be noted that earlier results used a source and receiver at 18.3 m. Also ICAPS considers reflection from the surface, absorption, bottom interactions, and coherent ray interaction.

The tables to be presented contain some representative samples of results for

- G from (13) or (30)
- Ray Tracing (RT)
- Previous calculator models (CALC) [Ref.1:p.75]
- Averaged ICAPS values [Ref.1:p.75]

Not all of the data are presented (the entire data set from the validation exceeds 2000 pages). The data presented are a subset from the complete data set which most closely matches the profiles used by earlier models. The tables are intended to show results from earlier estimations (CALC) as well as results from more complete models (ICAPS).

An exact fit the SSP's used by CALC and ICAPS could not be made as they are linearized by different methods. In determining G from equations (13) and (30) the best possible fit to the SSP's was made.

The SSP's from [Ref.1] were not included because only general types of SSP and not specific cases of profiles were not examined. The SSP's used are readily available in [Ref.1].

The ICAPS data is an averaged value and is obtained from [Ref.1] by the following process:

Two levels were chosen ... which bracket the majority of the TL points within the annulus. The approximate midpoint between those levels was then picked as "the" TL for that CZ. [Ref.1:p.40]

B. BILINEAR SSP

Table 1 presents the data resulting from use of equation (13) along with the RT, CALC, and ICAPS data. The SSP's numbered 18 through 20 [Ref.1:pp.18-20] correspond to SSP's from the Pacific Ocean for May, August, and November respectively. Note the agreement between the results from equation (13) and RT. Also note that overall a closer estimate to the averaged ICAPS data is obtained with equation (13) than was obtained with CALC.

TABLE I - BILINEAR SSP CZ GAINS IN DB (PACIFIC OCEAN)

SSP Number	(13)	RT	ICAPS	CALC
18	17.2	17.2	16.4	15.8
19	18.2	18.2	15.8	18.0
20	15.3	15.3	14.0	10.0

Table II presents the data from use of equation (13) along with the RT, CALC, and ICAPS data. For the SSP's numbered 26 through 28 [Ref.1:pp.26-28] corresponding to the SSP's from the Mediterranean Sea for May, August, and November respectively. The February SSP from the Mediterranean Sea did not have the proper gradient structure to allow the formation of a convergence zone.

TABLE II - BILINEAR SSP CZ GAINS IN DB (MEDITERRANEAN SEA)

SSP Number	(13)	RT	ICAPS	CALC
26	17.5	17.7	14.0	18.0
27	19.6	19.7	17.7	17.0
28	15.4	15.4	13.0	17.0

As with the Pacific Ocean data, the results from equation (13) agree closely with ray tracing (less than 1% on average). Table III presents the percent error between the averaged ICAPS data and equation (13), ray tracing, and CALC.

TABLE III - BILINEAR SSP - AVERAGE PERCENT ERRORS FROM ICAPS

(13)	RT	CALC
13.9	14.3	18.2

C. BILINEAR WITH ISOSPEED LAYER SSP

The approximation of the bilinear case (13) was used rather than (19) because of the complexity involved in evaluating θ_{in} by (19). Although (19) could be programmed on a computer as (13) and (30) were, the thickness of the isospeed layer does not enter significantly into the range equations (unless h is greater than 250 m.). The appropriate SSP's [Ref. 1:pp.21-24] are labeled 21 through 24 in Table IV. These SSP's correspond to profiles from the Atlantic Ocean for February, May, August, and November.

TABLE IV - BILINEAR WITH ISOSPEED LAYER SSP'S
(ATLANTIC OCEAN)

SSP Number	(13)	RT	ICAPS	CALC
21	16.7	16.7	15.5	5.0
22	15.8	15.7	16.5	16.0
23	17.4	17.4	16.0	18.0
24	15.2	15.2	12.0	17.0

Again, the solution obtained from use of (13) agrees closely with the solution obtained from ray tracing. The Atlantic Ocean SSP's were more difficult to segment

because of a more complex sound speed structure. This difficulty has also been noted in previous model development [Ref.1:p.66]. Table V presents the percent error between the averaged ICAPS data and equation (13), ray tracing, and CALC.

TABLE V - BILINEAR WITH ISOSPEED LAYER SSP - AVERAGE PERCENT ERRORS FROM ICAPS

(13)	RT	CALC
11.9	11.4	31.2

D. BILINEAR WITH A MIXED LAYER SSP

Table VI presents the data resulting from use of equation (30) along with the ray tracing, ICAPS, and CALC results. Only one SSP, numbered 17 [Ref.1:p.17], was appropriate for the bilinear with mixed layer SSP case. This SSP corresponds to the SSP from the Pacific Ocean for February and was the only profile which contained a mixed layer.

TABLE VI - BILINEAR WITH MIXED LAYER SSP'S (PACIFIC OCEAN)

SSP Number	(30)	RT	ICAPS	CALC
17	17.3	14.2	13.4	8.0

Table VII present the percent error from the averaged ICAPS data and equation (30), ray tracing and CALC.

TABLE VII - BILINEAR WITH MIXED LAYER SSP -
PERCENT ERRORS FROM ICAPS

(30)	RT	CALC
29.1	6.1	40.3

The unusually high percentage error for (30) in this case is a direct repercussion of setting the surface sound speed equal to the sound axis speed. In fact there was about a 12 m/s difference existed between c_2 and c_1 .

V. CONCLUSIONS

A. MODEL LIMITATIONS

Having an estimate for G based upon a bilinear or bilinear with mixed layer SSP would be sufficient if only those specific SSP's existed. Previous models have had the same limitations of how to segment the SSP [Ref.1:p.78]. A balance must be maintained between practicality and desired level of accuracy. For instance in this research when an isospeed layer was inserted into the bilinear SSP, analysis for θ_{in} quickly became unmanageable. Notice in (30) how the addition of a simple mixed layer to the bilinear SSP added to the complexity of (13). The addition of another layer requires two more parameters to be introduced and will increase the complexity of the gain equation. This becomes quite complicated. Though higher speed computers (to get even faster in the near future) can perform complicated algorithms swiftly and with those algorithms can come even closer to an exact solution to ray tracing, the intention was not to develop an exact solution but a good estimate.

This model, as in previous work [Ref.1:p.78], does not check for the bottom limited sound ray. If the bottom topography interfered with part of the beam the Δr_{CZ} would change and thus G .

As noted earlier, with the sound speeds relatively close (less than about 2 m/s), the model becomes invalid.

The estimates were developed for a source and receiver on the surface. Consequently, the model has no dependency upon source or receiver depth.

The bottom gradient is fixed at 0.017 m/s/m. Little effort would be required to make this change, but the operator would be required to input more data. Additionally, the sound speed at the bottom depth may not be known.

CZGAIN will not run on all MS-DOS machines. High resolution graphics capability is required, but the base equations (10), (13), (26), and (30) can be coded into practically any computer, even a calculator or a Macintosh.

The surface sound speed and sound speed at the sound axis must be equal for (30) to be valid. Minor deviations from this requirement may still be evaluated with (30), but the extent of the deviation allowable is unknown.

B. MODEL PRACTICALITY

In determining practicality, the desirable qualities presented in the introduction will be considered.

1. Data Requirements

The user/operator is required to have an SSP simple enough so that no more than three sound speeds and three depths are needed. If the SSP can be approximated by a bilinear profile, the mixed layer information may be omitted.

2. Output

The output of CZGAIN gives the user a repeat of the inputs in text and graphical formats. Additionally, graphical information on the width of the CZ and range to the inner edge of the CZ are presented.

3. Speed

CZGAIN runs in less time than it takes to input the data. Any of the input data may be quickly modified without having to reenter all data. Earlier models took in excess of nine minutes once the data has been entered [Ref.1:p.80].

4. Program Foundation

Ray tracing theory and not general guidelines or thumbrules were used in the development of the models.

C. COMPARISON TO EARLIER MODELS

The results from the model agreed closely with the values obtained from larger more complicated models (ICAPS). Furthermore, the estimates for G developed were closer in value to ICAPS than earlier models [Ref.1:p.75]. This is particularly interesting since earlier models used a more highly segmented SSP and used an iterative solution rather than an analytical one [Ref.1:p.50]. Also, a tighter requirement was placed on this model for an acceptable difference, 3 dB *vice* 7.3 dB [Ref.1:p.81]. Validation was not performed on the programs developed previously [Ref.1] so no validation comparison was able to be made.

D. GENERAL

The estimates for CZ gain were developed using ray tracing theory. Equation (13) is the estimated solution for G for the bilinear and bilinear with isospeed layer SSP's. Using various combinations of sound speeds and gradients, and thickness of the isospeed layer where appropriate, the solution for G obtained from (13) agreed more closely with the solution for G from ray tracing as well as ICAPS. Equation (30) is the estimated solution for G for the bilinear with mixed layer SSP. This equation was developed under the condition of the surface and sound axis sound speeds being equal. As long as this condition was met, the solution from (30) and solution from ray tracing agreed fairly well (no ICAPS data was available). As long as the SSP's do vary from this requirement, equations (13) and (30) give a reasonable estimates of the convergence zone gain.

LIST OF REFERENCES

1. Badger, R. L., *Convergence Zone Prediction Models with Programs for Use on HP-67 and HP-97 Programmable Calculators*, Master's Thesis, Naval Postgraduate School, Monterey, California, March 1979.
2. Urick, R. J., *Principles of Underwater Sound*, 3rd Ed., McGraw-Hill Book Company, 1983.
3. Kinsler, L. E., *et al*, *Fundamentals of Underwater Acoustics*, 3rd ed., John Wiley & Sons, Inc., 1982.
4. Defense Advanced Research Projects Agency, Office of the Secretary of Defense, *Sound Propagation in the Sea*, 1979.

APPENDIX A - SERIES EXPANSIONS

Several expansions are used throughout the development of various equations.

The following is a synopsis of those used.

A. TRIGONOMETRIC SERIES EXPANSIONS

1. Cosine θ

$$\cos \theta = 1 - \frac{\theta^2}{2!} + \frac{\theta^4}{4!} - \frac{\theta^6}{6!} + \frac{\theta^8}{8!} - \dots$$

2. Tangent θ

$$\tan \theta = \theta + \frac{\theta^3}{3} + \frac{2\theta^5}{15} + \frac{17\theta^7}{315} + \frac{62\theta^9}{2835} + \dots$$

$$\text{where } |\theta| < \frac{\pi}{2}$$

B. BINOMIAL SERIES EXPANSION

$$\left(\frac{1}{1-\theta} \right)^2 = 1 + 2\theta + 3\theta^2 + 4\theta^3 + 5\theta^4 + 6\theta^5 + \dots$$

$$\text{where } \theta^2 < 1$$

APPENDIX B

```
CC RESWPT2.FOR
CC
CC Program to evaluate the estimation angle to the inner edge of
CC the reswept zone and the CZ gain. An iteration of the range
CC equation is performed to obtain the true value. Finally, the
CC percent error of the angle of the ray to the inner edge and CZ gain
CC as compared to the iteration value are calculated.
CC
CC by Al Jenkins
CC
REAL*8 c_0, c_1, g_0, g_1, R_0, R_1, theta_0, theta_1,
+      range_e_min, range_i_min, temp_range, G, gamma,
+      range_outer, theta_e, theta_i,
+      Gain_iter, Gain_est
LOGICAL theta_min
INTEGER i, counter

OPEN (UNIT=1, ACCESS= 'APPEND', FILE= 'reswpt2a.dat',
+     STATUS= 'UNKNOWN')
OPEN (UNIT=2, ACCESS= 'APPEND', FILE= 'reswpt2b.dat',
+     STATUS= 'UNKNOWN')
OPEN (UNIT=3, ACCESS= 'APPEND', FILE= 'reswpt2c.dat',
+     STATUS= 'UNKNOWN')

WRITE(1,9000)

theta_min = .FALSE.
counter = 0

g_1 = 0.003
DO 400 m = 1, 10
WRITE( *,* ) m
c_1 = 1475
DO 300 l = 1, 10
g_0 = .017
DO 200 k = 1, 10
c_0 = 1489
```

```

DO 100 j = 1,10

IF( c_0 .GT. c_1 ) THEN

G = 1 + g_0 / g_1
gamma = c_1 / c_0

theta_min = .FALSE.

theta_0 = SQRT( (1-gamma**2) / (G**2-1) )
theta_1 = acos( c_1 * cos(theta_0) / c_0 )
theta_e = theta_0
R_0_ = c_0 / ( g_0 * cos(theta_0) )
R_1_ = c_1 / ( g_1 * cos(theta_1) )

range_e_min = R_0_ * ( sin(theta_1) - sin(theta_0) ) +
+ R_1_ * sin(theta_1)

theta_0 = 0
theta_1 = acos( c_1 * cos(theta_0) / c_0 )
R_0_ = c_0 / ( g_0 * cos(theta_0) )
R_1_ = c_1 / ( g_1 * cos(theta_1) )
range_outer = R_0_ * ( sin(theta_1) - sin(theta_0) ) +
+ R_1_ * sin(theta_1)
temp_range = range_outer

DO 10 i=1,10000
IF( .NOT. theta_min ) THEN
theta_0 = theta_0 ÷ 0.000035
theta_1 = acos( c_1 * cos(theta_0) / c_0 )
R_0_ = c_0 / ( g_0 * cos(theta_0) )
R_1_ = c_1 / ( g_1 * cos(theta_1) )
range_i_min = R_0_ * ( sin(theta_1) - sin(theta_0) ) +
+ R_1_ * sin(theta_1)
CC Loops set up so as to write only the minimum angle and range
IF (range_i_min.LT.temp_range) THEN
temp_range=range_i_min
ELSE IF (.NOT. theta_min) THEN
range_i_min = temp_range
theta_min=.TRUE.
theta_i = theta_0
ENDIF
ENDIF

```

10 CONTINUE

```
error = (theta_i - theta_e) / theta_i
error = 100 * ABS( error)
WRITE(2,9010) error
IF( error .GE. 5 )
+   WRITE(1,9001) c_0, g_0, c_1, g_1, theta_e, theta_i, error
counter = counter + 1
```

```
Gain_iter = 10 * LOG10( 2* range_i_min /
+   ( range_outer - range_i_min ) )
Gain_est = 10 * LOG10( 2* SQRT( G**2 - 1) / (G - SQRT(G**2 -1)))
error = (Gain_iter - Gain_est) / Gain_iter
error = 100 * ABS( error)
WRITE(3,9010) error
IF( (error*Gain_iter) .GE. 3 )
+   WRITE(1,9002) Gain_iter, Gain_est, theta_e, theta_i, error
END IF
```

```
c_0 = c_0 + 6
100 CONTINUE
g_0 = g_0 + 0.0229
200 CONTINUE
c_1 = c_1 + 5
300 CONTINUE
g_1 = g_1 + 0.002
400 CONTINUE
```

```
WRITE( 1, * ) counter
CLOSE (1, STATUS= 'KEEP')
CLOSE (2, STATUS= 'KEEP')
9000 FORMAT (1X,'c0',8X,'g0',8X,'c1',8X,'g1',8X,'t-e',6X,'t-i',6X,
+   '% Error')
9001 FORMAT (1X,F6.1,3X,F5.3,6X,F5.0,4X,F5.3,6X,F5.4,4X,F5.4,4X,F9.6)
9002 FORMAT (1X,F6.2,3X,F6.2,6X,F5.4,4X,F5.4,4X,F9.6)
9010 FORMAT (1X,F13.8)
9100 FORMAT( 1X, F7.3, 4X, F7.3, 3X, F6.1, 3X, F5.3, 6X, F5.0, 4X,
+   F5.3, 2X, F4.1 )
9101 FORMAT( 1X, F4.1, 4X, F4.1)
END
```

APPENDIX C

```
CC RESWPT3.FOR
CC
CC Program to evaluate the estimation angle to the inner edge of
CC the reswept zone and the CZ gain. An iteration of the range
CC equation is performed to obtain the true value. Finally, the
CC percent error of the angle of the ray to the inner edge and CZ gain
CC as compared to the iteration value are calculated. h is the thickness
CC of the isospeed layer
CC
CC by Al Jenkins
CC
    REAL*8 c_0, c_1, g_0, g_1, R_0, R_1, theta_0, theta_1,
+         range_e_min, range_i_min, temp_range, G, gamma,
+         range_outer, theta_e, theta_i,
+         Gain_iter, Gain_est, h
    LOGICAL theta_min
    INTEGER i, j, k, l, m, n, counter

    OPEN (UNIT=1, ACCESS= 'APPEND', FILE= 'reswpt3a.dat',
+        STATUS= 'UNKNOWN')
    OPEN (UNIT=2, ACCESS= 'APPEND', FILE= 'reswpt3b.dat',
+        STATUS= 'UNKNOWN')
    OPEN (UNIT=3, ACCESS= 'APPEND', FILE= 'reswpt3c.dat',
+        STATUS= 'UNKNOWN')

    WRITE(1,9000)

    theta_min = .FALSE.
    counter = 0
    h=0

    DO 500 n = 1,10
    g_1 = 0.003
    DO 400 m = 1, 10
    WRITE( *,* ) n,m
    c_1 = 1475
    DO 300 l = 1, 10
    g_0 = .017
```

```

DO 200 k = 1, 10
c_0 = 1489
DO 100 j = 1,10

```

```

IF( c_0 .GT. c_1 ) THEN

```

```

G = 1 + g_0 / g_1
gamma = c_1 / c_0

```

```

theta_min = .FALSE.

```

```

theta_0 = SQRT( (1-gamma**2) / (G**2-1) )
theta_1 = acos( c_1 * cos(theta_0) / c_0 )
theta_e = theta_0
R_0 = c_0 / ( g_0 * cos(theta_0) )
R_1 = c_1 / ( g_1 * cos(theta_1) )

```

```

range_e_min = R_0 * ( sin(theta_1) - sin(theta_0) ) +
+ R_1 * sin(theta_1) + h * cotan( theta_1 )

```

```

theta_0 = 0
theta_1 = acos( c_1 * cos(theta_0) / c_0 )
R_0 = c_0 / ( g_0 * cos(theta_0) )
R_1 = c_1 / ( g_1 * cos(theta_1) )
range_outer = R_0 * ( sin(theta_1) - sin(theta_0) ) +
+ R_1 * sin(theta_1) + h * cotan( theta_1 )
temp_range = range_outer

```

```

DO 10 i=1,10000

```

```

IF( .NOT. theta_min ) THEN

```

```

theta_0 = theta_0 + 0.000035
theta_1 = acos( c_1 * cos(theta_0) / c_0 )
R_0 = c_0 / ( g_0 * cos(theta_0) )
R_1 = c_1 / ( g_1 * cos(theta_1) )
range_i_min = R_0 * ( sin(theta_1) - sin(theta_0) ) +
+ R_1 * sin(theta_1) + h * cotan( theta_1 )

```

CC Loops set up so as to write only the minimum angle and range

```

IF (range_i_min.LT.temp_range) THEN

```

```

temp_range=range_i_min

```

```

ELSE IF (.NOT. theta_min) THEN

```

```

range_i_min = temp_range

```

```

theta_min=.TRUE.

```

```

theta_i = theta_0

```

```

ENDIF
ENDIF
10 CONTINUE

error = (theta_i - theta_e) / theta_i
error = 100 * ABS( error)
WRITE(2,9010) error
IF( error .GE. 5 )
+   WRITE(1,9001) c_0, g_0, c_1, g_1, theta_e, theta_i, error
counter = counter + 1

Gain_iter = 10 * LOG10( 2* range_i_min /
+   ( range_outer - range_i_min) )
Gain_est = 10 * LOG10( 2* SQRT( G**2 - 1) / (G - SQRT(G**2 -1)))
error = (Gain_iter - Gain_est) / Gain_iter
error = 100 * ABS( error)
WRITE(3,9010) error
IF( (error*Gain_iter) .GE. 3 ) THEN
  WRITE(1,9001) c_0, g_0, c_1, g_1, h
  WRITE(1,9002) Gain_iter, Gain_est, theta_e, theta_i, error
ENDIF
END IF

c_0 = c_0 + 5.2
100 CONTINUE
g_0 = g_0 + 0.0229
200 CONTINUE
c_1 = c_1 + 5
300 CONTINUE
g_1 = g_1 + 0.002
400 CONTINUE
h = h + 25
500 CONTINUE

WRITE( 1, * ) counter
CLOSE (1, STATUS= 'KEEP')
CLOSE (2, STATUS= 'KEEP')
9000 FORMAT (1X,'c0',8X,'g0',8X,'c1',8X,'g1',8X,'t-e',6X,'t-i',6X,
+   '% Error')
9001 FORMAT (1X,F6.1,3X,F5.3,6X,F5.0,4X,F5.3,6X,F5.1,4X,F5.4,4X,F9.6)
9002 FORMAT (1X,F6.2,3X,F6.2,6X,F5.4,4X,F5.4,4X,F9.6)
9010 FORMAT (1X,F13.8)
9100 FORMAT( 1X, F7.3, 4X, F7.3, 3X, F6.1, 3X, F5.3, 6X, F5.0, 4X,

```

```
      + F5.3, 2X, F4.1 )  
9101  FORMAT( 1X, F4.1, 4X, F4.1)  
      END
```

APPENDIX D

CC RESWPT4.FOR

CC

CC Program to test the estimated value for theta against the
CC iterative value of theta for the inner edge of the reswept zone
CC of a convergence zone.

CC

CC by Al Jenkins

CC

```
REAL*8 c_0, c_1, g_0, g_1, R_0, R_1, theta_0, theta_1,  
+      range_e_min, range_i_min, temp_range, G, gamma,  
+      range_outer, theta_e, theta_i, height, c_2, g_2,  
+      H, eta, R_2  
LOGICAL theta_min  
INTEGER i, j, k, l, m, n, o, p, counter
```

```
OPEN (UNIT=1, ACCESS= 'APPEND', FILE= 'RESWPT4A.DAT',  
+     STATUS= 'UNKNOWN')  
OPEN (UNIT=2, ACCESS= 'APPEND', FILE= 'RESWPT4B.DAT',  
+     STATUS= 'UNKNOWN')  
OPEN (UNIT=3, ACCESS= 'APPEND', FILE= 'RESWPT4C.DAT',  
+     STATUS= 'UNKNOWN')
```

```
WRITE(1,9000)
```

```
theta_min = .FALSE.  
counter = 0
```

```
g_2 = 0.01  
DO 700 p = 1,10
```

```
c_2 = 1475  
DO 600 o = 1,10
```

```
height = 0  
DO 500 n = 1,1
```

```

g_1 = 0.008
DO 400 m = 1, 5
WRITE( *,* ) m, n, o, p

```

```

c_1 = 1475
DO 300 l = 1, 1

```

```

g_0 = .01
DO 200 k = 1, 1

```

```

c_0 = 1476
DO 100 j = 1,10

```

```

IF( c_0 .GT. c_1 .AND. c_0 .GT. c_2 ) THEN

```

```

G    = 1 + g_0 / g_1
gamma = c_1 / c_0
H    = 1 + g_0 / g_2
eta  = c_2 / c_0

```

```

theta_min = .FALSE.

```

```

theta_0 = H * SQRT( 1 - gamma**2 ) / SQRT( ( G + g_0/g_2)**2 -
+ H**2 )

```

```

theta_1 = acos( gamma * cos(theta_0) )

```

```

theta_2 = acos( eta * cos(theta_0) )

```

```

theta_e = theta_0

```

```

R_0 = c_0 / ( g_0 * cos(theta_0) )

```

```

R_1 = c_1 / ( g_1 * cos(theta_1) )

```

```

R_2 = c_2 / ( g_2 * cos(theta_2) )

```

```

range_e_min = R_0 * ( sin(theta_1) - sin(theta_0) ) +
+ R_1 * sin(theta_1) + R_2 * ( sin(theta_2) - sin(theta_0) )

```

```

theta_0 = 0

```

```

theta_1 = acos( gamma * cos(theta_0) )

```

```

theta_2 = acos( eta * cos(theta_0) )

```

```

R_0 = c_0 / ( g_0 * cos(theta_0) )

```

```

R_1 = c_1 / ( g_1 * cos(theta_1) )

```

```

R_2 = c_2 / ( g_2 * cos(theta_2) )

```

```

range_outer = R_0 * ( sin(theta_1) - sin(theta_0) ) +
+ R_1 * sin(theta_1) + R_2 * ( sin(theta_2) - sin(theta_0) )

```

```

temp_range = range_outer

```

```

DO 10 i=1,10000
IF( .NOT. theta_min ) THEN
  theta_0 = theta_0 + 0.000035
  theta_1 = acos( gamma * cos(theta_0) )
  theta_2 = acos( eta * cos(theta_0) )
  R_0 = c_0 / ( g_0 * cos(theta_0) )
  R_1 = c_1 / ( g_1 * cos(theta_1) )
  R_2 = c_2 / ( g_2 * cos(theta_2) )
  range_i_min = R_0 * ( sin(theta_1) - sin(theta_0) ) +
+ R_1 * sin(theta_1) + R_2 * ( sin(theta_2) - sin(theta_0) )
CC Loops set up so as to write only the minimum angle and range
IF (range_i_min.LT.temp_range) THEN
  temp_range=range_i_min
ELSE IF (.NOT. theta_min) THEN
  theta_min=.TRUE.
  theta_i = theta_0
ENDIF
ENDIF
10 CONTINUE
IF( .NOT. theta_min ) WRITE( 1,* ) counter
error = (theta_i - theta_e) / theta_i
error = 100 * ABS( error)
WRITE(2,9010) error
IF( error .GE. 5 )
+ WRITE(1,9001) c_0, g_0, c_1, g_1, theta_e, height, error
counter = counter + 1

Gain_iter = 10*LOG10(2*range_i_min/(range_outer-range_i_min))
Gain_est = 10*LOG10(2*SQRT(((G+g_0/g_2)**2-H**2)/((G+g_0/g_2)-
+ SQRT((g+g_0/g_2)**2-H**2)))
error = (Gain_iter - Gain_est) / Gain_iter
error = 100 * ABS( error)
WRITE(3,9010) error
IF( (error*Gain_iter) .GE. 3 ) THEN
  WRITE(1,9001) c_0, g_0, c_1, g_1, height
  WRITE(1,9002) Gain_iter, Gain_est, theta_e, theta_i, error
ENDIF

ENDIF

c_0 = c_0 + 7.5
100 CONTINUE

```

```

    g_0 = g_0 + 0.04
200  CONTINUE

    c_1 = c_1 + 5
300  CONTINUE

    g_1 = g_1 + 0.004
400  CONTINUE

    height = height
500  CONTINUE

    c_2 = c_2 + 5
600  CONTINUE

    g_2 = g_2 + 0.005
700  CONTINUE

    WRITE( 1, * ) counter
    CLOSE (1, STATUS= 'KEEP')
    CLOSE (2, STATUS= 'KEEP')
9000  FORMAT (1X,'c0',8X,'g0',8X,'c1',8X,'g1',8X,'t-e',6X,'h',6X,
+         '% Error')
9001  FORMAT (1X,F6.1,3X,F5.3,6X,F5.0,4X,F5.3,6X,F5.4,4X,F5.0,4X,F13.6)
9002  FORMAT (1X,F6.2,3X,F6.2,6X,F5.4,4X,F5.4,6X,F13.6)
9010  FORMAT (1X,F13.8)
    END

```

APPENDIX E

```
CC GAIN.FOR
CC
CC Program for finding the CZ gain
CC
CC by Al Jenkins
CC
```

```
INCLUDE 'FGRAPH.FI'
INCLUDE 'FGRAPH.FD'
```

```
LOGICAL fourcolors
EXTERNAL fourcolors
REAL*8 c0, c1, c2, h, d0, d1, d3
```

```
c WRITE (*,*) ' Enter c0 - '
c READ (*,*) c0
c WRITE (*,*) ' Enter d0 - '
c READ (*,*) d0
c WRITE (*,*) ' Enter c1 - '
c READ (*,*) c1
c WRITE (*,*) ' Enter d1 - '
c READ (*,*) d1
c WRITE (*,*) ' Enter c2 - '
c READ (*,*) c2
c WRITE (*,*) ' Enter h - '
c READ (*,*) h
c WRITE (*,*) ' Enter d3 - '
c READ (*,*) d3
```

```
c0 = 1500
c1 = 1475
c2 = 1490
h = 250
d0 = 100
d1 = 500
d3 = 3000
```

```

IF ( fourcolors() ) THEN
    CALL plot_all(c0, c1, c2, h, d0, d1, d3)
ELSE
    WRITE (*,*) ' This program requires...'
END IF
END

CC
CC
CC FOURCOLORS -
CC p.180 Advanced Topics Guide
CC Microsoft Corporation
CC
    LOGICAL FUNCTION fourcolors()

    INCLUDE 'FGRAPH.FD'

    INTEGER*2 dummy
    RECORD /videoconfig/ screen
    COMMON screen

C
C Set to max number of available colors.
C

    CALL getvideoconfig( screen )
    SELECT CASE( screen.adapter )
        CASE( $CGA, $OCGA )
            dummy = setvideomode( $MRES4COLOR )
        CASE( $EGA, $OEGA )
            dummy = setvideomode( $ERESCOLOR )
        CASE( $VGA, $OVGA )
            dummy = setvideomode( $VRES16COLOR )
        CASE DEFAULT
            dummy = 0
    END SELECT

    CALL getvideoconfig( screen )
    fourcolors = .TRUE.
    IF( dummy .EQ. 0 ) fourcolors = .FALSE.
    END

CC
CC

```

CC PLOT_ALL Displays the graphs

CC

CC

SUBROUTINE plot_all(c0, c1, c2, h, d0, d1, d3)

INCLUDE 'FGRAPH.FD'

REAL*8 c0, c1, c2, h, d0, d1, d3

INTEGER*2 dummy, halfx, halfy, xwidth, yheight

INTEGER*2 cols, rows

RECORD /videoconfig/ screen

COMMON screen

CHARACTER*1 string, getch

RECORD /rccoord/ curpos

10 CONTINUE

C

C Find screen dimensions

C

CALL clearscreen (\$GCLEARSCREEN)

xwidth = screen.numxpixels

yheight = screen.numypixels

cols = screen.numtextcols

rows = screen.numtextrows

halfx = xwidth/2 * 0.8

halfy = (yheight/rows)*(rows/2)

C

C Sound Speed window

C

CALL setviewport(0, 0, halfx , halfy)

CALL settextwindow(1, 1, rows / 2, cols / 2)

dummy = setwindow(.TRUE., -2.0, -1.2, 2.0, 1.75)

CALL sound_speed(c0, c1, c2, h, d0, d1, d3)

dummy = rectangle (\$GBORDER, 0, 0, halfx - 4, halfy - 2)

C

C Range vs. Theta window

C

CALL setviewport(halfx - 2, 0, xwidth-1, yheight - 1)

CALL settextwindow(1, (cols/2-5) , rows, cols)

dummy = setwindow(.TRUE., -2.0, -2.0, 2.0, 2.0)

CALL range_plot(c0, c1, c2, h, d0, d1)

dummy = rectangle_w(\$GBORDER, -2.0, -2.0, 2.0, 2.0)

C

C Graph Description Window

C

```
CALL setviewport( 0, halfy+1, halfx-1, yheight-1)
CALL settextwindow( rows / 2 + 1, 0, rows, cols / 2 )
dummy = setwindow( .TRUE., -2.0, -1.2, 2.0, 1.75 )
CALL graph_description( c0, d0, c1, d1, d3, h, c2 )
dummy = rectangle ($GBORDER, 0, 0, halfx - 4, halfy - 2 )
```

C

C Check for increasing, adding, raising sound speed at surface

C

```
CALL settextposition( 0, 0, curpos )
string = getch()
SELECT CASE( string )
CASE( '1' )
    GOTO 20
CASE( '!', 'A', 'a' )
    GOTO 25
CASE( '2' )
    GOTO 30
CASE( '@', 'S', 's' )
    GOTO 35
CASE( '3' )
    GOTO 40
CASE( '#', 'D', 'd' )
    GOTO 45
CASE( '4' )
    GOTO 50
CASE( '$', 'F', 'f' )
    GOTO 55
CASE( '5' )
    GOTO 60
CASE( '%', 'G', 'g' )
    GOTO 65
CASE( '6' )
    GOTO 70
CASE( '^', 'H', 'h' )
    GOTO 75
CASE( 'E', 'e', 'Q', 'q' )
    GOTO 100
CASE DEFAULT
    GOTO 10
```

END SELECT
GOTO 10

20 c2 = c2 - 1
IF (c2.LE.c1) c2 = c2 + 1
IF (c2.LE.0) c2 = c2 + 1
GOTO 10

25 c2 = c2 + 1
IF (c2.GE.c0) c2 = c2 - 1
GOTO 10

30 c0 = c0 - 1
IF (c0.LE.c2) c0 = c0 + 1
IF (c0.LE.c1) c0 = c0 + 1
IF (c0.LE.0) c0 = c0 + 1
GOTO 10

35 c0 = c0 + 1
GOTO 10

40 d0 = d0 - 5
IF (d0.LE.0) d0 = d0 + 5
GOTO 10

45 d0 = d0 + 5
IF (d0.GE.d1) d0 = d0 - 5
GOTO 10

50 c1 = c1 - 1
IF (c1.LE.0) c1 = c1 + 1
GOTO 10

55 c1 = c1 + 1
IF (c1.GE.c2) c1 = c1 - 1
IF (c1.GE.c0) c1 = c1 - 1
GOTO 10

60 d1 = d1 - 5
IF (d1.LE.d0) d1 = d1 + 5
GOTO 10

65 d1 = d1 + 5
IF (d1.GE.(d3 - h)) d1 = d1 - 5
GOTO 10

70 h = h - 5
IF (h.LT.0) h = h + 5
GOTO 10

75 h = h + 5
IF (h.GE.(d3 - d1 - d0)) h = h - 5
GOTO 10

```
100 CONTINUE
    dummy = setvideomode ( $DEFAULTMODE )
    END
```

```
CC
```

```
CC
```

```
CC SOUND_SPEED Subroutine to plot the sound speed profile
```

```
CC
```

```
CC
```

```
    SUBROUTINE sound_speed(c0, c1, c2, h, d0, d1, d3)
```

```
    INCLUDE 'FGRAPH.FD'
```

```
    REAL*8 c0, c1, c2, h, d0, d1, d3
```

```
    INTEGER*2 dummy
```

```
    DOUBLE PRECISION x, y, scale_x
```

```
    RECORD /videoconfig/ screen
```

```
    RECORD /wxycoord/ wxy
```

```
    RECORD /rccoord/ curpos
```

```
    COMMON screen
```

```
    CHARACTER*8 string
```

```
    dummy = settextcolor( 15 )
```

```
    CALL settextposition( 8, 2, curpos )
```

```
    CALL outtext( 'Depth' )
```

```
    CALL settextposition( 2, 10, curpos )
```

```
    CALL outtext( 'Sound Speed' )
```

```
    CALL settextposition( 3, 12, curpos )
```

```
    dummy = settextcolor( 14 )
```

```
    WRITE (string, '(I4)')INT( c2 )
```

```
    CALL outtext( ' ' // string // ' ' )
```

```
    CALL settextposition( 3, 19, curpos )
```

```
    dummy = settextcolor( 12 )
```

```
    WRITE (string, '(I4)')INT( c0 )
```

```
    CALL outtext( ' ' // string // ' ' )
```

```
C
```

```
C Draw border
```

```
C
```

```
    dummy = setcolor( 1 )
```

```
    dummy = rectangle_w( $GBORDER, -1.00, -1.00, 1.00, 1.00 )
```

```
    dummy = rectangle_w( $GBORDER, -1.02, -1.02, 1.02, 1.02 )
```

C

C Plot points

C

```
scale_x = - 50.0
dummy = setcolor( 14 )
CALL moveto_w( 0, 1, wxy )
x = scale_x * ( 1 - c0 / c2 )
y = 1 - 2 * d0 / d3
dummy = lineto_w( x, y )
CALL moveto_w( x, y, wxy )
x = scale_x * ( 1 - c1 / c2 )
y = 1 - 2 * d1 / d3
dummy = lineto_w( x, y )
CALL moveto_w( x, y, wxy )
y = 1 - 2 * ( d1 + h ) / d3
dummy = lineto_w( x, y )
CALL moveto_w( x, y, wxy )
x = scale_x * (1-(c1+0.017*(d3-d1-h))/c2)
dummy = lineto_w( x, -1 )
dummy = setcolor( 3 )
```

C

C Plot points for bilinear profile

C

```
dummy = setcolor( 12 )
x = scale_x * ( 1 - c0 / c2 )
CALL moveto_w( x, 1, wxy )
x = scale_x * ( 1 - c1 / c0 )
y = 1 - 2 * d1 / d3
dummy = lineto_w( x, y )
CALL moveto_w( x, y, wxy )
x = scale_x * (1-(c1+0.017*(d3-d1))/c0)
dummy = lineto_w( x, -1 )
dummy = setcolor( 3 )
END
```

CC

CC

CC RANGE_PLOT Subroutine for plotting range versus theta

CC

CC

```
SUBROUTINE range_plot(c0, c1, c2, h, d0, d1)
```

```
INCLUDE 'FGRAPH.FD'
```

```

INTEGER*2 dummy, i
DOUBLE PRECISION x, y, theta_2, range_scale
DOUBLE PRECISION theta, theta_graph, range, range_graph
REAL*8 unit_dimension, range_12, theta_12, gamma, G
REAL*8 range_14, theta_14
REAL*8 c0, c1, c2, d0, d1, h, scale_r, scale_t
RECORD /videoconfig/ screen
RECORD /wxycoord/ wxy
RECORD /rccoord/ curpos
COMMON screen
CHARACTER*8 string

```

C

C Label grid

C

```

    dummy = settextcolor( 13 )
    CALL settextposition( 14, 0, curpos )
    CALL outtext( 'Range' )
    CALL settextposition( 15, 8, curpos )
    CALL outtext( ' 0' )
    CALL settextposition( 10, 8, curpos )
    CALL outtext( ' 2' )
    CALL settextposition( 4, 8, curpos )
    CALL outtext( ' 4' )
    CALL settextposition( 21, 8, curpos )
    CALL outtext( '-2' )
    CALL settextposition( 27, 8, curpos )
    CALL outtext( '-4' )

    CALL settextposition( 35, 11, curpos )
    CALL outtext( '0 2 4 6 8 Theta' )

```

C

C Draw border

C

```

    dummy = setcolor( 1 )
    dummy = rectangle_w( $GBORDER, -1.00, -1.80, 1.90, 1.90 )
    dummy = rectangle_w( $GBORDER, -1.02, -1.82, 1.92, 1.92 )

```

C

C Draw Grid

C

```

    x = -0.71
    y = -1.48
    DO i = 1, 9

```

```

dummy = setcolor( 8 )
CALL moveto_w( x, -1.8, wxy )
dummy = lineto_w( x, 1.9 )
CALL moveto_w( -1.0, y, wxy )
dummy = lineto_w( 1.9, y )
y      = y + 0.37
x      = x + 0.29
END DO
C
C Plot curve
C
g0 = ABS( (c0 - c1) / (d1 - d0) )
g1 = ABS( 0.017 )
g2 = ABS( (c1 - c2) / d0 )

C Set scaling factor for vertical axis, based on bilinear profile
gamma = c1 / c0
G      = 1 + g0 / g1
theta = SQRT( ( 1 - gamma**2 ) / ( G**2 - 1 ) )
theta_1 = acos( c1 * cos(theta) / c0 )
theta_2 = acos( c2 * cos(theta) / c0 )

c range = (c0/(g0*cos(theta)))*((1+g0/g1)*DSQRT(1-(c1/c0)**2 *
c + cos(theta)**2) - sin(theta)) +
c + h*cotan(acos((c1/c0)*cos(theta)))
range = c2/(g2*cos(theta_2)) * (sin(theta_2) - sin(theta)) +
+ c0/(g0*cos(theta)) * (sin(theta_1) - sin(theta)) +
+ h * cotan(theta_1) +
+ c1/(g1*cos(theta_1)) * sin(theta_1)
range_scale = 0.045 * range

dummy = setcolor( 14 )
scale_r = 1.0
C Set horizontal scale so that 1.5 degrees equals 0.1 across the
C total width of 2.9
scale_t = 11.07718404
theta_graph = -1.0
range_graph = 0
theta = 0
theta_1 = acos( c1 * cos(theta) / c0 )
theta_2 = acos( c2 * cos(theta) / c0 )

g0 = ABS( (c0 - c1) / (d1 - d0) )

```

```

g1 = ABS( 0.017 )
g2 = ABS( (c0 - c2) / d0 )

```

```

range = c2/(g2*cos(theta_2)) * (sin(theta_2) - sin(theta)) +
+ c0/(g0*cos(theta)) * (sin(theta_1) - sin(theta)) +
+ h * cotan(theta_1) +
+ c1/(g1*cos(theta_1)) * sin(theta_1)

```

C Vertical dimension for each graph square in meters
unit_dimension = range_scale / scale_r

C Dimensions for the graph for the full profile in meters and radians
range_14 = 2 * range
theta_14 = theta_2

DO i = 1, 100

CALL moveto_w(theta_graph, range_graph, wxy)

theta = theta + .0026179939

theta_1 = acos(c1 * cos(theta) / c0)

theta_2 = acos(c2 * cos(theta) / c0)

range_graph =

```

+ c2/(g2*cos(theta_2)) * (sin(theta_2) - sin(theta)) +
+ c0/(g0*cos(theta)) * (sin(theta_1) - sin(theta)) +
+ h * cotan(theta_1) +
+ c1/(g1*cos(theta_1)) * sin(theta_1)

```

range_graph = (range_graph - range) / range_scale

C Scaling factor for the graph

range_graph = scale_r * range_graph

theta_graph = scale_t * theta - 1

dummy = lineto_w(theta_graph, range_graph)

END DO

C

C Plot the non-mixed layer curve

C

dummy = setcolor(12)

theta_graph = -1.0

theta = 0.0

range_graph = 0.0

g0 = ABS((c0 - c1) / d1)

theta_1 = acos(c1 * cos(theta) / c0)

```

range = c0/(g0*cos(theta)) *
+ (sin(theta_1) - sin(theta)) +

```

+ $c0/(g1*\cos(\theta)) * \sin(\theta_1)$

C Dimensions for the graph for the bilinear profile in meters and radians

range_12 = 2 * range

theta_12 = 0

DO i = 1, 100

CALL moveto_w(theta_graph, range_graph, wxy)

theta = theta + .0026179939

theta_1 = $\text{acos}(c1*\cos(\theta)/c0)$

range_graph = $c0/(g0*\cos(\theta)) *$

+ $(\sin(\theta_1) - \sin(\theta)) +$

+ $c1/(g1*\cos(\theta_1)) * \sin(\theta_1)$

range_graph = $(\text{range_graph} - \text{range}) / \text{range_scale}$

C Scaling factor for graph

range_graph = scale_r * range_graph

theta_graph = scale_t * theta - 1

dummy = lineto_w(theta_graph, range_graph)

END DO

C

C Put a plus for the estimated minimum range and its angle

C

dummy = setcolor(15)

gamma = $c1 / c0$

G = $1 + g0 / g1$

theta = $\text{SQRT}((1 - \text{gamma}^{**2}) / (G^{**2} - 1))$

range = $(c0/(g0*\cos(\theta))) * ((1+g0/g1)*\text{DSQRT}(1-(c1/c0)^{**2} *$

+ $\cos(\theta)^{**2}) - \sin(\theta))$

range_graph = $(\text{range} / \text{range_12}) - 1$

c WRITE(*,*) range_12, range

range_graph = scale_r * range_graph

theta_graph = scale_t * theta - 1

c CALL moveto_w(theta_graph-0.05, range_graph, wxy)

c dummy = lineto_w(theta_graph+0.05, range_graph)

c CALL moveto_w(theta_graph, range_graph-0.05, wxy)

c dummy = lineto_w(theta_graph, range_graph+0.05)

C

C Reference information for the graph

C

dummy = settextcolor(13)

CALL settextposition(2, 14, curpos)

WRITE (string, '(F4.1)') unit_dimension / 1852

CALL outtext('Unit dimensions: ')

```

CALL settextposition( 3, 13, curpos )
CALL outtext( ' 1.5 deg by' // string // 'nmi  ' )
dummy = settextcolor( 12 )
CALL settextposition( 4, 12, curpos )
WRITE( string, '(F5.1)' ) range_12 / 1852
CALL outtext( 'Range (0) = ' // string // 'nmi  ' )
CALL settextposition( 5, 12, curpos )
WRITE( string, '(F4.2)' ) theta_12 * 57.29578
CALL outtext( 'Theta (0) = ' // string // ' ' )
CALL settextposition( 5, 32, curpos )
CALL outtext( 'degrees' )
dummy = settextcolor( 14 )
CALL settextposition( 6, 12, curpos )
WRITE( string, '(F5.1)' ) range_14 / 1852
CALL outtext( 'Range (0) = ' // string // 'nmi  ' )
CALL settextposition( 7, 12, curpos )
WRITE( string, '(F5.2)' ) theta_14 * 57.29578
CALL outtext( 'Theta (0) = ' // string // ' ' )
CALL settextposition( 7, 32, curpos )
CALL outtext( 'degrees' )
dummy = settextcolor( 15 )
CALL settextposition( 8, 12, curpos )
WRITE( string, '(F5.1)' ) range / 926
CALL outtext( 'Range (+) = ' // string // 'nmi  ' )
CALL settextposition( 9, 12, curpos )
WRITE( string, '(F5.2)' ) theta * 57.29578
CALL outtext( 'Theta (+) = ' // string // ' ' )
CALL settextposition( 9, 32, curpos )
CALL outtext( 'degrees' )
dummy = setcolor( 3 )
END

```

```

CC
CC
CC
CC
CC

```

```

Subroutine for the graph description

```

```

SUBROUTINE graph_description( c0, d0, c1, d1, d3, h, c2 )

```

```

INCLUDE 'FGRAPH.FD'

```

```

REAL*8 c0, d0, c1, d1, c3, d3, h, g1, g2, g0, gain_bilinear,
+   gain_mxdlyr, theta, R0, R1, R2, max_range, CZ_width, theta_1,
+   theta_2, min_range, temp, c2

```

```
CHARACTER*8 string
RECORD /videoconfig/ screen
RECORD /rccoord/ curpos
COMMON screen
```

```
C
C Information on the sound speed vs. depth graph
C
```

```
dummy = settextcolor(15)
CALL settextposition( 2, 2, curpos )
CALL outtext( ' Depth,m   Sound Speed, m/s' )
dummy = settextcolor(14)
CALL settextposition( 3, 2, curpos )
WRITE (string, '(I5)')INT( d0 )
CALL outtext( ' ' // string // ' ' )
CALL settextposition( 3, 15, curpos )
WRITE (string, '(I5)')INT( c0 )
CALL outtext( ' ' // string // ' ' )
CALL settextposition( 4, 2, curpos )
WRITE (string, '(I5)')INT( d1 )
CALL outtext( ' ' // string // ' ' )
CALL settextposition( 4, 15, curpos )
WRITE (string, '(I5)')INT( c1 )
CALL outtext( ' ' // string // ' ' )
CALL settextposition( 5, 2, curpos )
WRITE (string, '(I5)')INT( d1 + h )
CALL outtext( ' ' // string // ' ' )
CALL settextposition( 5, 15, curpos )
WRITE (string, '(I5)')INT( c1 )
CALL outtext( ' ' // string // ' ' )
CALL settextposition( 6, 2, curpos )
WRITE (string, '(I5)')INT( d3 )
CALL outtext( ' ' // string // ' ' )
CALL settextposition( 6, 15, curpos )
c3 = c1+0.017*(d3-d1-h)
WRITE (string, '(I5)')INT( c3 )
CALL outtext( ' ' // string // ' ' )
```

```
C
C Gain information, bilinear then mixed layer
C
```

```
temp = temp
gain_mxdlyr = 0
g0 = ABS( (c0 - c1) / (d1 - d0) )
```

```
g1 = ABS( 0.017 )
g2 = ABS( (c1 - c2) / d0 )
```

```
gain_bilinear = 10 * LOG10( (2 * SQRT( (1+g0/g1)**2-1 )) /
+ ( (1+g0/g1) - SQRT( (1+g0/g1)**2-1 )))
```

```
dummy = settextcolor(12)
CALL settextposition( 8, 2, curpos )
CALL outtext( ' CZ Gain =' )
CALL settextposition( 8, 12, curpos )
WRITE (string, '(F4.1)') gain_bilinear
CALL outtext( ' ' // string // ' ' )
CALL settextposition( 8, 18, curpos )
CALL outtext( 'db')
```

```
gain_mxdlyr = 10 * LOG10( (2 * SQRT( (1+g0/g1+g0/g2)**2-1 )) /
+ ( (1+g0/g1+g0/g2) - SQRT( (1+g0/g1+g0/g2)**2-1 )))
```

```
dummy = settextcolor(14)
CALL settextposition( 10, 2, curpos )
CALL outtext( ' CZ Gain =' )
CALL settextposition( 10, 12, curpos )
WRITE (string, '(F4.1)') gain_bilinear
CALL outtext( ' ' // string // ' ' )
CALL settextposition( 10, 18, curpos )
CALL outtext( 'db')
```

```
END
```

APPENDIX F

USER'S MANUAL FOR CZ GAIN

CZGAIN requires an MS-DOS based system with high resolution graphics capability (VGA or better). The model was developed using ray tracing rather than normal mode theory.

The user inputs the following data:

- Surface sound speed, m/s
- Depth of mixed layer, m
- Sound speed at bottom of mixed layer, m/s
- Minimum sound speed below the mixed layer, m/s
- Depth of that sound speed, m/s
- Bottom depth, m

While the bottom sound speed gradient is fixed at 0.017 /s, the bottom depth is used when drawing SSP's.

The surface sound speed and minimum sound speed will always be less than the sound speed at the bottom of the mixed layer.

The depth of the mixed layer will be no less than 1 meter.

The thickness of the isospeed layer will be zero or greater.

When developing the keys to use for the data manipulation, efforts were made to tie each data point to a specific mnemonic (e.g. Thickness of isospeed layer changed by t). No standard convention could be established. The numbers work from left to right on sound speed and depth pairs. Where no depth or sound speed was used (e.g. surface depth is always zero) that key was used for the next parameter. The numbers always decrease the respective value and using the SHIFT key with the number always increases the respective value. The letters were added at the programmers personal convenience. No enter key is required, the program

automatically captures the keystroke and recomputes the output. The following is a list of keys which will manipulate the data.

- 1 - Decreases surface sound speed
- !, A, a - Increases surface sound speed
- 2 - Decreases sound speed at bottom of mixed layer
- @, S, s - Increases sound speed at bottom of mixed layer
- 3 - Decreases depth of mixed layer
- #, D, d - Increases depth of mixed layer
- 4 - Decreases minimum sound speed
- \$, F, f - Increases minimum sound speed
- 5 - Decreases depth of minimum sound speed
- %, G, g - Increases depth of minimum sound speed
- 6 - Decreases thickness of isospeed layer
- ^, H, h - Increases thickness of isospeed layer
- 7 - Decreases bottom depth
- &, J, j - Increases bottom depth
- Q, q, E, e - Exits the program

If the program is modified, the Key Entry Functions (if using Microsoft Fortran) patch will need to be installed into the proper libraries before compiling.

BIBLIOGRAPHY

Beckes, M.E., Burhans, N.P., and Gump, R.E., *Passive Environmental ASW Prediction System (PEAPS)*, Master's Thesis, Naval Postgraduate School, Monterey, California, March 1975.

Coppens, A.B, Dahl, H.A., and Sanders, J.V., *An Introduction to the Sonar Equations with Applications (Revised)*, Naval Postgraduate School, February 1979.

Madden, L., *Pocket-Proploss Programs and Models for the Computation of Acoustic Transmission Loss on Hand-Held Calculators*, Master's Thesis, Naval Postgraduate School, Monterey, California, March 1977.

Microsoft Corporation, *Microsoft FORTRAN, Advanced Topics*, 1989.

Microsoft Corporation, *Microsoft FORTRAN, Reference*, 1989.

Naval Ocean Systems Center, Technical Report 997, *Comparison of Experimental Detailed Convergence-Zone Structure with Results of Uniform Asymptotic Ray Theory*, by M.A. Pedersen, D.F. Gordon, and R.F. Hosmer, 15 December 1985.

Officer, C., *Introduction to the Theory of Sound Transmission*, McGraw-Hill Book Company, INC., 1958.

Podeszwa, E.M., *A Slide Rule for Predicting Convergence Zones*, U.S. Navy Underwater Sound Laboratory, USL Report No. 877, 22 April 1969.

Shudde, R.H., *Naval Applications: Ten Algorithms for the Hewlett-Packard HP-67 and HP-97 Calculators*, Naval Postgraduate School, Report No. NPS55-79-04, February 1979.

United States Navy Underwater Sound Laboratory, Fort Trumbull, New London, Connecticut, USL Report Number 877, *A Slide Rule for Predicting Convergence Zones*, by E.M. Podeszwa, 22 April 1969.

Urick, R.J., *Sound Propagation in the Sea*, Defense Advanced Research Projects Agency, 1979.

INITIAL DISTRIBUTION LIST

1. Defense Technical Information Center 2
Cameron Station
Alexandria, Virginia 22304-6145
2. Library, Code 52 2
Naval Postgraduate School
Monterey, California 93943-5002
3. Associate Professor A.B. Coppens 2
Code PH/Cz
Department of Physics
Naval Postgraduate School
Monterey, California 93943
4. Associate Professor J.V. Sanders 1
Code 33A
Department of Physics
Naval Postgraduate School
Monterey, California 93943
6. Mr. D. Stewart 1
RW-52
Patuxent River NAS, Maryland 20670
5. Mr. A.K. Jenkins 2
RW-52L
Patuxent River NAS, Maryland 20670