

**BBN Systems and Technologies**

A Division of Bolt Beranek and Newman Inc.

1

**AD-A244 208**



**BBN Report No. 7626**

**DTIC**  
ELECTE  
JAN 08 1992  
**S D D**

**MULTIRAD**  
**NETWORK DESIGN**  
**SPECIFICATION**

This document has been approved  
for public release and sale; its  
distribution is unlimited.

**92-00269**



**92 1 6 077**

Report No. 7626



# MULTIRAD NETWORK DESIGN SPECIFICATION

JUNE 1991

Accession For	
NTIS CRA&I	<input checked="" type="checkbox"/>
DTIC TAB	<input type="checkbox"/>
Unannounced	<input type="checkbox"/>
Justification .....	
By .....	
Distribution / .....	
Availability Codes	
Dist	Avail and/or Special
A-1	

**Prepared by:**

BBN Systems and Technologies  
Advanced Simulation  
10 Moulton Street  
Cambridge, MA 02138 USA

**APPROVED FOR PUBLIC RELEASE  
DISTRIBUTION UNLIMITED**

**Prepared for:**

Defense Advanced Research Projects Agency (DARPA)  
1400 Wilson Blvd.  
Arlington, VA 22209-2308

This research was performed by BBN Systems and Technologies under Contract No. MDA972-90-C-0061 to the Defense Advanced Research Projects Agency (DARPA). The views and conclusions contained in this document are those of the authors and should not be interpreted as necessarily representing the official policy, either expressed or implied, of DARPA, the U.S. Army, or the U.S. Government.

## Table of Contents

SECTION 1. OVERVIEW .....	1
1.1 Scope .....	1
1.2 Target Audience .....	1
1.3 Logical Operation.....	1
1.4 Physical Equipment.....	1
1.5 Reference Documents.....	1
1.6 Terms and Abbreviations.....	2
SECTION 2. LOGICAL OPERATION.....	3
2.1 Protocol.....	3
2.1.1 General.....	3
2.1.2 Information Generation and Exchange .....	4
2.1.2.1 Protocol Hierarchy .....	4
2.1.3 Ethernet Controllers.....	4
2.1.3.1 Addresses.....	5
2.1.4 Types of Data.....	5
2.1.5 Protocol Extensions.....	6
2.2 Network Operation.....	8
2.2.1 Spine - Operation and Interface.....	6
2.3 Common Interface Modules.....	6
2.3.1 ST 500.....	6
2.3.2 MT 800.....	6
2.3.3 NIU (Network Interface Unit).....	7
2.3.4 DELNI .....	7
2.4 ISS - ISS (Instructional Support System).....	7
2.4.1 PVD (Plan View Display).....	7
2.4.2 Data Logger.....	7
2.4.3 NOM (Network Operation and Maintenance).....	7
2.5 GCI (Ground Control Intercept).....	8
2.6 Simulator Operation and Interface.....	8
2.6.1 ATES (Automated Threat Engagement System).....	8
2.6.2 MDRC (McDonnell Douglas Reconfigurable Cockpit) Simulator.....	8
2.6.3 AIT (Air-Intercept Trainer) Simulator .....	8
2.6.4 CET (Combat Engagement Trainer) Simulator .....	8
SECTION 3. PHYSICAL EQUIPMENT.....	9
3.1 Building 561 Layout .....	9
3.2 Equipment Layout.....	12
3.2.1 Overall Block Diagram .....	11
3.2.1.1 Common Equipment .....	12
3.2.1.2 ISS (Instructional Support System .....	13
3.2.1.3 GCI (Ground Control Intercept) Station.....	14
3.2.1.4 ATES (Automated Threat Engagement System) .....	15
3.2.1.5 MDRC (McDonnell Douglas Reconfigurable Cockpit) ..	16
3.2.1.5 AIT (Air Intercept Trainer) Simulator .....	17
3.2.1.6 CET #1 & 2 (Combat Engagement Trainer) Simulators ..	18
SECTION 4. PERFORMANCE CHARACTERISTICS.....	19

### List of Figures

Figure 2-1.	SIMNET Architecture .....	3
Figure 2-2.	Protocol Hierarchy .....	4
Figure 3-1.	Bldg. 561 Layout .....	10
Figure 3-2.	MULTIRAD Network Block Diagram .....	11
Figure 3-3.	ISS Block Diagram .....	13
Figure 3-4.	GCI Block Diagram .....	14
Figure 3-5.	ATES Block Diagram .....	15
Figure 3-6.	MDRC Block Diagram .....	16
Figure 3-7.	AIT #1 Block Diagram .....	17
Figure 3-8.	CET #1 & 2 Block Diagram .....	18

### List of Tables

Table 1-1.	General Reference Documents .....	1
Table 1-3.	Terms and Abbreviations .....	2
Table 2-1.	Simulator to NIU Communications .....	5
Table 2-2.	Data Types ..	5
Table 3-1.	Equipment Modules .....	12

**SECTION 1. OVERVIEW**

**1.1 Scope**

The scope of this document describes all of the simulators and associated equipment on the MULTIRAD network at the Armstrong Laboratory and details of the protocol required to operate the system.

This covers the MULTIRAD network installation using a superset of SIMNET 6.6 protocol (SIMNET 6.6 plus updates and extensions) as it is currently implemented at this site. Additions and extensions to SIMNET 6.6 are included in this document, but not any future plans. The system description addresses only simulators and stations connected as a part of the MULTIRAD network. Equipment functions are described at the block diagram level, as generic devices whenever possible. When brand name devices are specified, detailed information on individual vendors equipment must be obtained from them. Other specifications and source documents are referred to whenever necessary for additional information.

**1.2 Target Audience.**

This document is intended for a broad range of personnel. The audience includes occasional system users, engineering staff and administrative personnel.

**1.3 Logical Operation.**

The operating protocol is described in SECTION 2, LOGICAL OPERATION. This starts with an overview of SIMNET 6.6 followed by an operational explanation of stations/simulators and how they interface with the overall system.

**1.4 Physical Equipment.**

The MULTIRAD network is composed of many pieces of electronic gear. The pieces of equipment used, location of each piece, their functions and physical relationships to others are described in SECTION 3, PHYSICAL EQUIPMENT. This includes the ISS (Instructional Support System), GCI (Ground Control Intercept), ATES (Automated Threat Engagement System), and all the simulators in the MULTIRAD network.

**1.5 Reference Documents.**

The documents listed in Table 1-1 are recommended to provide background information.

**Table 1-1. General Reference Documents.**

<u>TITLE</u>	<u>DATE</u>
The SIMNET Network and Protocols, BBN Report 7102, 31 July, 1989, Rev. 1.2.	15 October, 1990.
Network Interface Unit Detailed Design Specification.	2 May, 1991.
The SIMNET Communications Protocol For Distributed Simulation.	
Network Operation Procedures, Version 1.2.	May 23, 1991.
ADD INTERFACE CONTROL DOCUMENTS IN THIS TABLE.	
ADD SPEC. 7935 HERE !!	

## 1.6 Terms and Abbreviations.

Common terms and abbreviations used in the MULTIRAD network environment are listed in Table 1-3.

**Table 1-3. Terms and Abbreviations.**

<b>AIT</b>	<b>Air-Intercept Trainer</b>
<b>ATES</b>	<b>Automated Threat Engagement System</b>
<b>CET</b>	<b>Combat Engagement Trainer</b>
<b>DARPA</b>	<b>Defense Advanced Research Projects Agency</b>
<b>DVG</b>	<b>Digital Voice Gateway</b> Software which encodes voice digitally for transmission over a network.
<b>GCI</b>	<b>Ground Control Intercept</b>
<b>ICD</b>	<b>Interface Control Document</b> A document describing an interface between two devices, in this case the NIU and a host.
<b>LANCE</b>	<b>Local Area Network Controller for Ethernet</b>
<b>MULTIRAD</b>	<b>Multiship Research and Development</b>
<b>NIU</b>	<b>Network Interface Unit</b> Connects a simulator to a SIMNET network.
<b>NOM</b>	<b>Network Operation and Maintenance</b>
<b>PDU</b>	<b>Protocol Data Unit</b> A SIMNET message. Packets are groups of PDUs which are encapsulated. The PDU is the SIMNET unit of network data.
<b>PVD</b>	<b>Plan View Display</b>
<b>SIMNET</b>	<b>Simulator Network</b> A DARPA network for connecting combat simulators.

SECTION 2. Logical Operation

2.1 Protocol.

2.1.1 General.

The MULTIRAD network uses a distributed simulation approach employing the SIMNET 6.6 protocol with some extensions and modifications. Distributed simulation operates in a particular network environment called a *distributed simulation internet*. This network environment may consist of a single local area network, or it may include a series of local area networks linked together by a long-haul network. Local area networks are referred to as sites, and the computers at each site (attached to a local area network are referred to as simulators. This arrangement is illustrated in Figure 2-1<sup>1</sup>

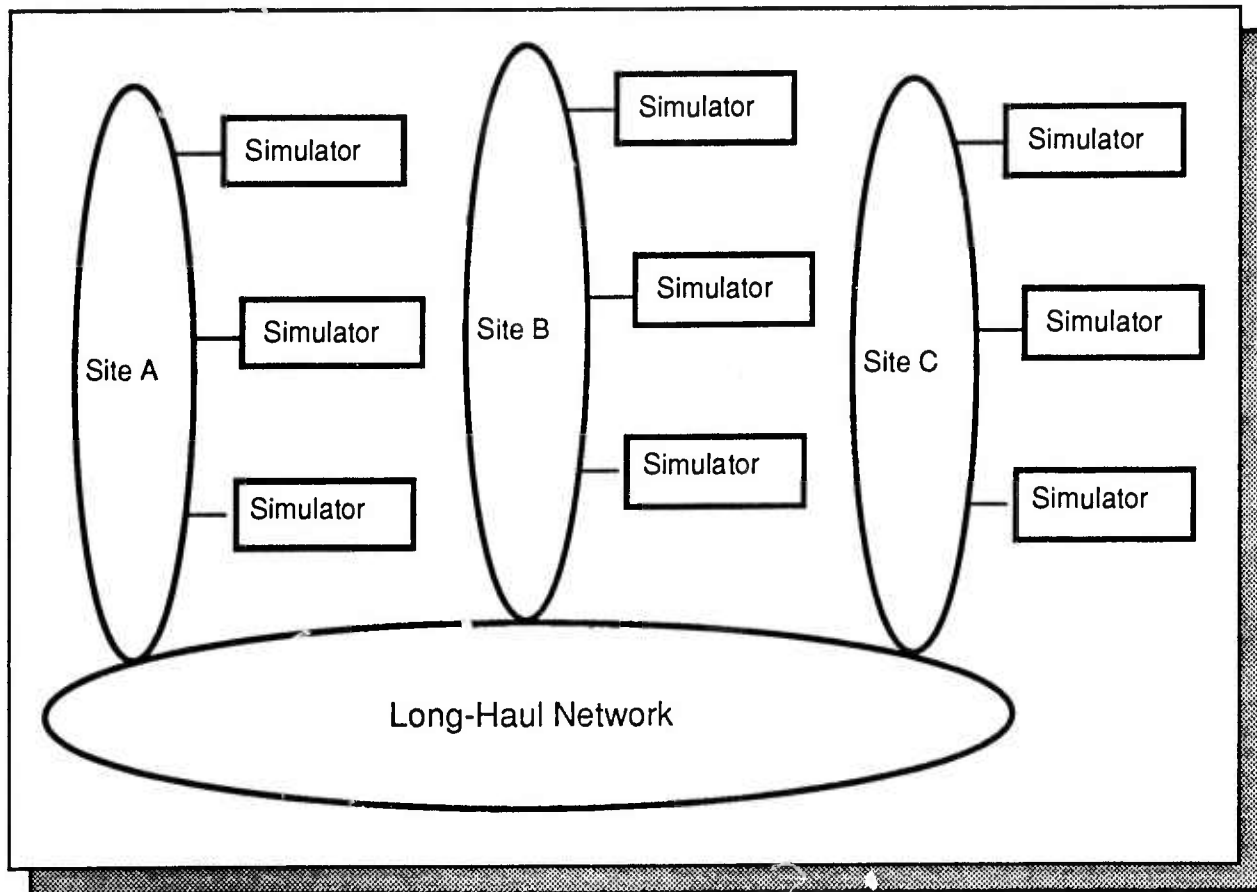

Figure 2-1 SIMNET Architecture.

<sup>1</sup> BBN Report 7102, The SIMNET Network and Protocols.

Instead of centralized simulation with one computer controlling all operations, each simulator operates independently. Each simulator can be activated by the NIU or the PVD. In this document only the local area network and simulators used at this site are discussed. SIMNET supports a variety of simulators, all aircraft at this site.

Several type of networks could be used with this protocol. MULTIRAD employs an IEEE 802.3 Ethernet LAN in this application. Long-Haul network capabilities are present, but not discussed in this document.

### **2.1.2. Protocol Hierarchy.**

Simulators may engage in other communications protocols besides those used to achieve distributed simulation. A simulator might implement additional protocols for functions such as remote diagnosis or bulk transfer of data, and use the same underlying communication service to support these additional protocols. This report however is only concerned with the three protocols that provide distributed simulation. Figure 2-2 shows how the three protocols and the underlying communication service are related to each other.<sup>1</sup>



Figure 2-2. Protocol Hierarchy.

### **2.1.3 Ethernet Controllers.**

Each NIU has an Ethernet controller with its own unique ID. IDs are discussed later in this document. The heart of each controller is the LANCE chip. The LANCE (Local Area Network Controller for Ethernet) is enabled by the software used with that NIU. It has two modes of operation, promiscuous and non-promiscuous. The promiscuous mode would allow the computer(s) in the NIU to subscribe to all traffic on the network. The NIUs are set to the non-promiscuous mode. In this mode, registers are enabled to receive specifically addressed data. This minimizes the time used to evaluate and process data.

<sup>1</sup> BBN Report 7102, The SIMNET Network and Protocols.

### 2.1.3.1 Addresses.

Each address is globally unique and assigned by a central authority. Addresses are six bytes long. The first three bytes are the manufacturers ID. The next three bytes are assigned by the manufacturer.

The type of address listened to and talked to by each unit are listed in **Table 2-1**.

**Table 2-1. Simulator to NIU Communications.**

<u>Simulator</u>	<u>ADDRESSES LISTENED TO</u>	<u>ADDRESSES TALKED TO</u>
AIT	BROADCAST and its own station address	MULTICAST
ATES	BROADCAST and its own station address	MULTICAST
CET	BROADCAST and its own station address	MULTICAST
GCI	MULTICAST	None
MDRC	MULTICAST	MULTICAST

### 2.1.4 Types of Data.

The various types of data used in the MULTIRAD network are listed and described in **Table 2-2**.

**Table 2-2. Data Types.**

<u>DATA TYPE</u>	<u>FUNCTION</u>
1. Appearance	Describes appearance changes due to muzzle flashes, bullet impacts, missile strikes, fire damage, etc.
2. Event	Carries data concerning occurrences such as guns firing and missile launches.
3. Attitude	Provides aircraft X, Y, and Z plane data.
4. Position	Provides global position data in coordinate system used by the network.

### 2.1.5 Protocol Extensions.

TBD

## 2.2 Network Operation.

Detailed information on startup and operation may be found in "Network Operating Procedures, Version 1.2, May 23, 1991."

### 2.2.1 Spine - Operation and Interface.

The network topology is important in that it must have a 50 Ohm termination and each simulator attachment must be at increments of one meter intervals. This provides impedance matching and prevents standing waves on the network.

### **2.3 Common Interface Modules.**

#### **2.3.1 ST 500.**

CABLETRON SYSTEMS Inc. ST 500-02. This unit is a physically intrusive tap that allows connection of 15 pin Transceiver cables to the Ethernet coaxial cable.

#### **2.3.2 MT 800**

CABLETRON SYSTEMS Inc., MT800 with Lanview, Multiport Transceiver Unit (MAU). The MT800 is a multinode tap that has one input and eight outputs. It appears electronically as part of the spine. It is a dual power supply unit that amplifies the input signal. MT800s contain an external network input thereby allowing daisy chaining (i.e. one output may be connected to the input of another MT800). Front panel indicator lights show traffic activity on each port and PDU collisions when they occur.

#### **2.3.3 NIU (Network Interface Unit).**

The NIU provides the capability to connect dissimilar simulators to an existing SIMNET network. The NIU transforms existing simulator data into SIMNET PDUs and provides additional overhead required to support the SIMNET protocol. The NIU allows simulators with non-homogeneous frame times to be inter-operable on the same network<sup>2</sup>

##### **2.3.3.1 NIU Functions.**

The NIU's main function is to perform Remote Vehicle Approximation (RVA) which requires the NIU to maintain low-fidelity models of other vehicles on the network. The network transmits updated information on vehicle attitude and position only when the low-fidelity models deviate from the actual model by a pre-defined threshold. The NIU translates data from host-specific protocols to PDUs and back. This involves both the repackaging of information in different data-structures as well as conversion of units of measure and coordinate systems. The NIU also provides host-specific filtering functions to prevent network traffic from overloading the host.

#### **2.3.4 DELNI**

DIGITAL EQUIPMENT Local Network Interface. This unit is a multinode tap that is similar to a MT800 but does not amplify signals or monitor activity.

### **2.4 ISS - ISS (Instructional Support System).**

The ISS is a collection of stations that can be operated independently of other Stations/Simulators on MULTIRAD. These include the PVD, Data Logger, and the Network Operation and Maintenance (NOM).

#### **2.4.1 PVD (Plan View Display)**

The PVD provides a Gods-Eye View of the exercise with a terrain display. The PVD can activate/de-activate any simulator that is interfaced to the MULTIRAD network and is powered up. Control data that can currently be set by the PVD are, latitude, longitude, altitude and heading.

---

<sup>2</sup> Network Interface Unit Detailed Design Specification

### **2.4.2 Data Logger.**

The Data Logger records all network activity on either tape or disk for later replay.

### **2.4.3 NOM (Network Operation and Maintenance).**

The NOM is installed but is not operational.

### **2.5 GCI (Ground Control Intercept)**

The GCI is operational but is not installed. The GCI simulates an airborne situation display for exercise control.

### **2.6 Simulator Operation and Interface.**

The SIMNET concept of a simulator includes the NIU, host computer, and the visual display as a unit. Simulators are capable of independent operation. Any simulator that is already powered up can also be activated by the PVD. Each simulator has a globally unique Simulator ID assigned to it. The Simulator ID contains three IDs of 16-bits each. These are, Site ID, Host ID, and Vehicle ID. The Site ID is assigned by BBN Cambridge; Host ID by site management; Vehicle ID by the simulator.

Each simulator does its own computing and generates its own State of the World (SOW) model which becomes shared data.

#### **2.6.1 ATES (Automated Threat Engagement System).**

TBD

#### **2.6.2 MDRC (McDonnell Douglas Reconfigurable Cockpit) Simulator**

The MDRC simulator is currently configured as an F-15C aircraft.

#### **2.6.3 AIT (Air-Intercept Trainer) Simulator.**

TBD

#### **2.6.4 CET (Combat Engagement Trainer) Simulator.**

TBD

## SECTION 3. PHYSICAL EQUIPMENT

### **3.1 Building 561 Layout.**

The layout of building 561 areas relating to the MULTIRAD network are shown in **Figure 3-1**. The relative location of the spine, stations, simulator bays, etc. are as illustrated and approximately to scale. All units are not shown in this figure for the sake of clarity.

### **3.2 Equipment Layout.**

The units comprising the MULTIRAD network are illustrated and described in this section. Their relative positions and physical locations are approximately the same as shown in the accompanying figures.

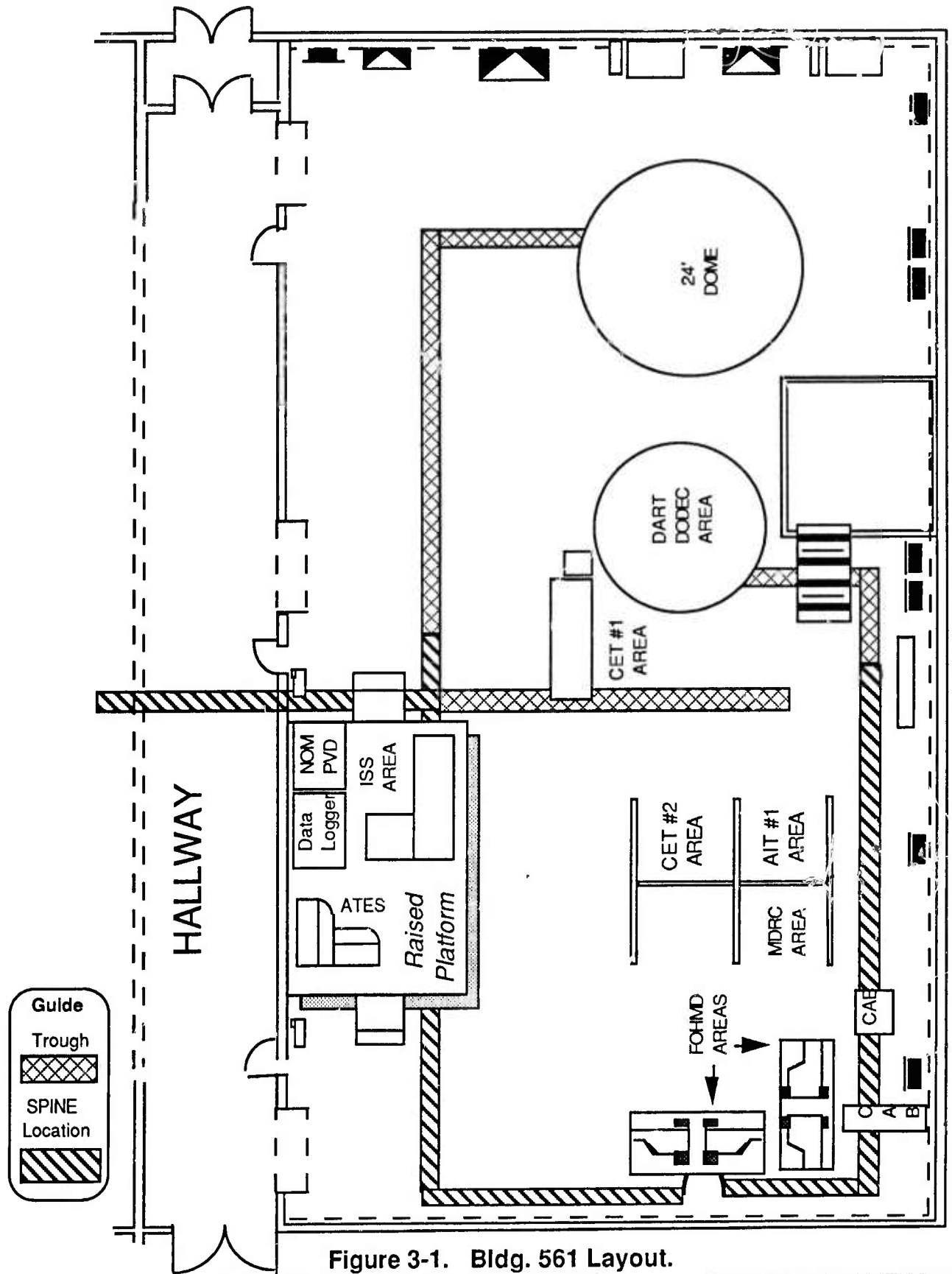

Figure 3-1. Bldg. 561 Layout.

**3.2.1 Overall Block Diagram**

Figure 3-2 shows the overall MULTIRAD network in block form. Only the main stations/simulators as currently configured are shown here. Other equipment shown in the Bldg. 561 Layout is not discussed here. The (1) Spine, runs in a trough from the computer rooms across the hall, makes a loop around the simulator area and ends with a 50 Ohm termination. One portion of the Spine is routed above the floor as indicated in the shaded area of the diagram.

The primary stations/simulators of the MULTIRAD system networked through the Spine are; (2) ISS, Instructional Support System station; (3) Ground Control Intercept station; (4) ATES, Automated Threat Engagement System station; (5) MDRC, McDonnell Douglas Re-configurable Cockpit simulator; (6) AIT, Air Intercept Trainer simulator; (7 & 8) CET #1 & 2, Combat Engagement Trainer simulators.

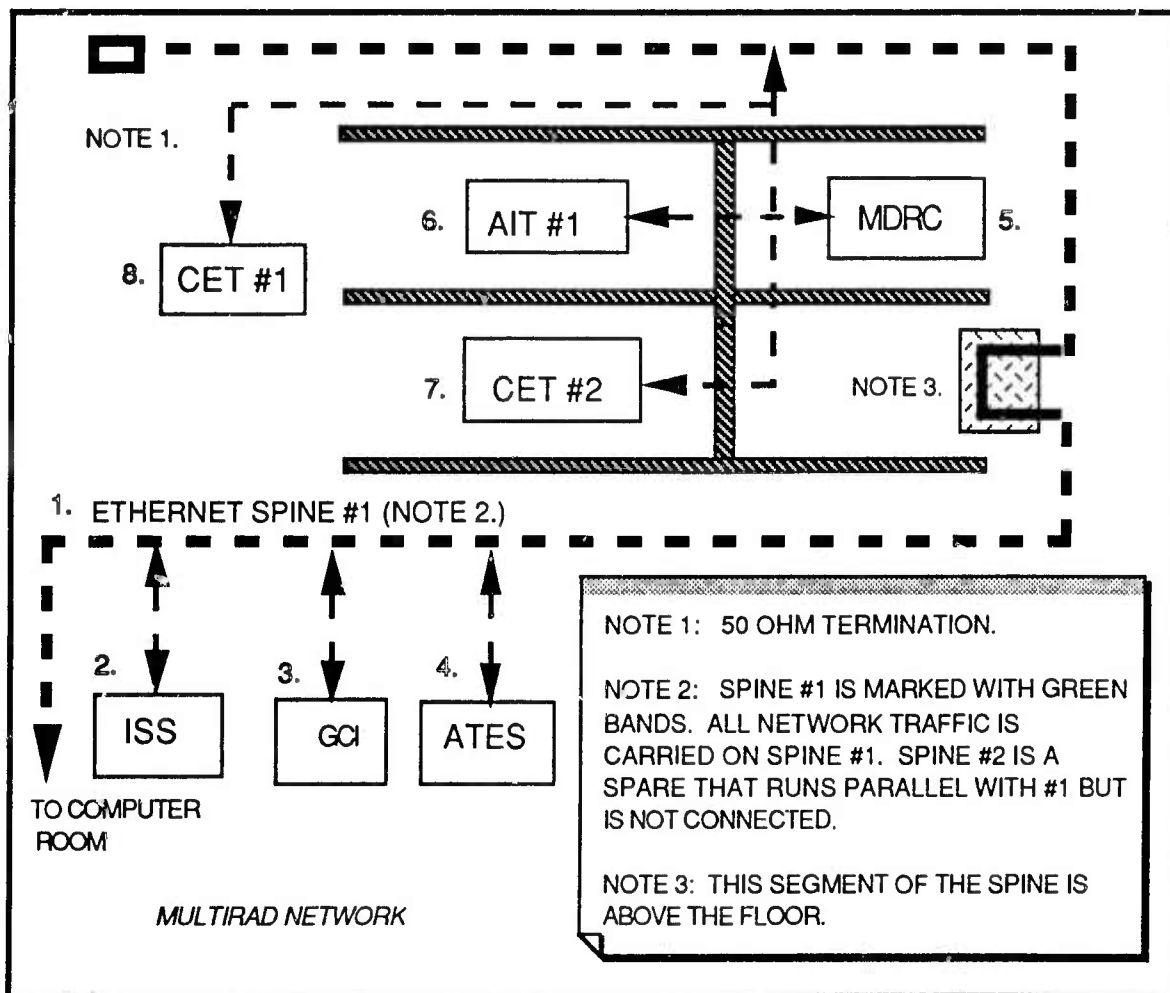

Figure 3-2. MULTIRAD Network Block Diagram

### **3.2.1.1 Common Equipment.**

The items of equipment listed in **Table 3-1** are used in several locations and frequently are shared between stations/simulators. Unique items are described with their associated station/simulator. Refer to paragraph 2.3 for additional information on these items

**Table 3-1 Equipment Modules**

<b>Spine</b>	50 Ohm coaxial cable used for the Ethernet LAN. Active cable is marked with green bands.
<b>ST500</b>	CABLETRON SYSTEMS Inc., Transceiver unit. This is an intrusive tap that clamps on the spine.
<b>MT800</b>	CABLETRON SYSTEMS Inc., MT800 with Lanview, Multiport Transceiver Unit (MAU). This is a dual power supply unit.
<b>NIU</b>	Network Interface Unit.
<b>DESTA</b>	TBD. Interconnection boxes between thick and thin wires. Eliminates the need for a transceiver.
<b>DELNI</b>	DIGITAL EQUIPMENT Local Network Interface. This is a multinode tap; many other brands could be used.

**3.2.1.2 ISS (Instructional Support System)**

The ISS station equipment is illustrated in Figure 3-3. A (1) ST500 clamps on the Ethernet Spine providing connection between it and (2) a MT800 Multiport Transceiver Unit via 15-pin transceiver cables. This type of cable is used for interconnections shown here. The MT800 outputs are routed to the (3) PVD, Plan View Display, (4) Data Logger, and (5) NOM, Network Operation and Maintenance. Additional outputs from this MT800 go to the GCI and ATES. The PVD, Data Logger, and the NOM are located on the platform area illustrated in Figure 3-1.

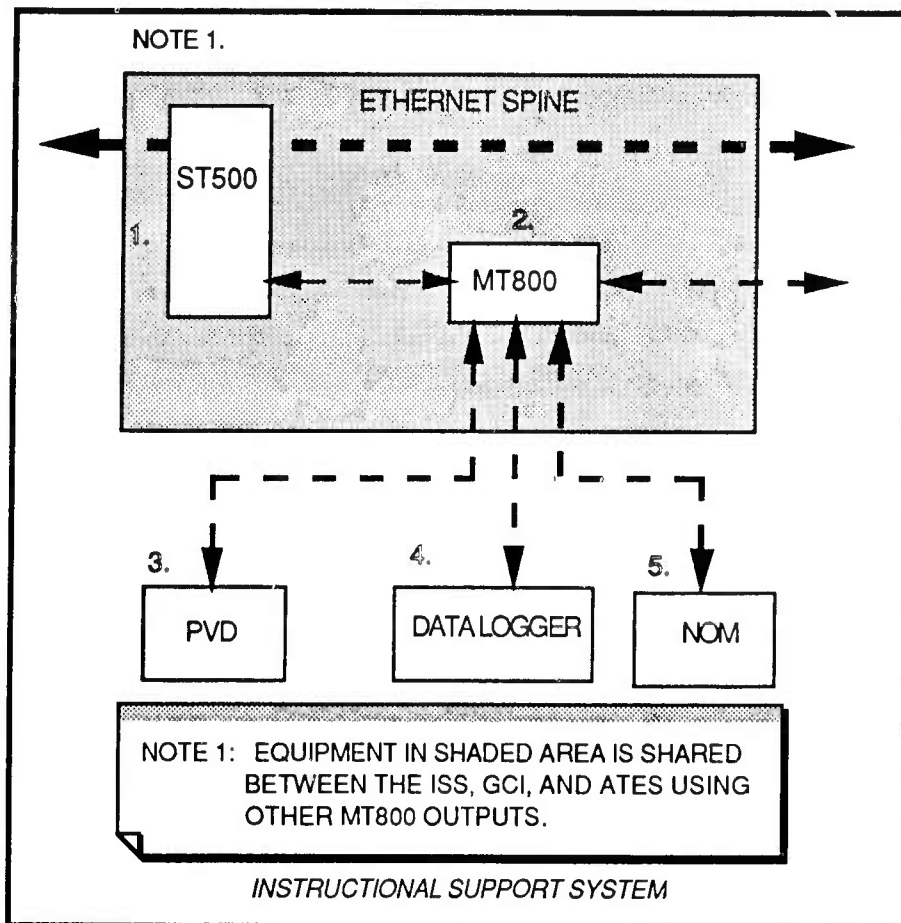

**Figure 3-3. ISS Block Diagram**

**3.2.1.3 GCI (Ground Control Intercept) Station.**

The GCI station equipment is illustrated in Figure 3-4. The same (1) ST500 and (2) MT800 used with the ISS and ATEs are employed here using other outputs of the MT800. Again, 15-pin transceiver cables are used for all interconnections shown here. The (3) NIU translates both voice and data for the (4) GCI. The GCI and NIU are located on the same platform area as the ISS and ATEs.

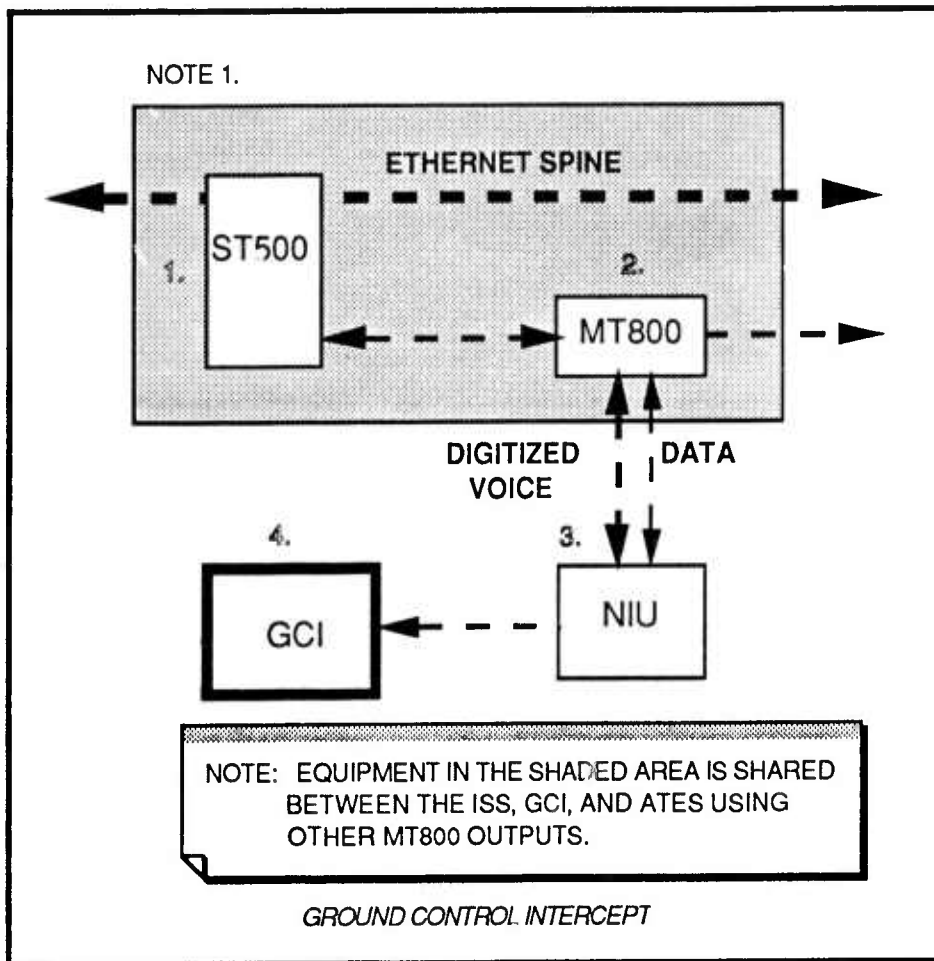
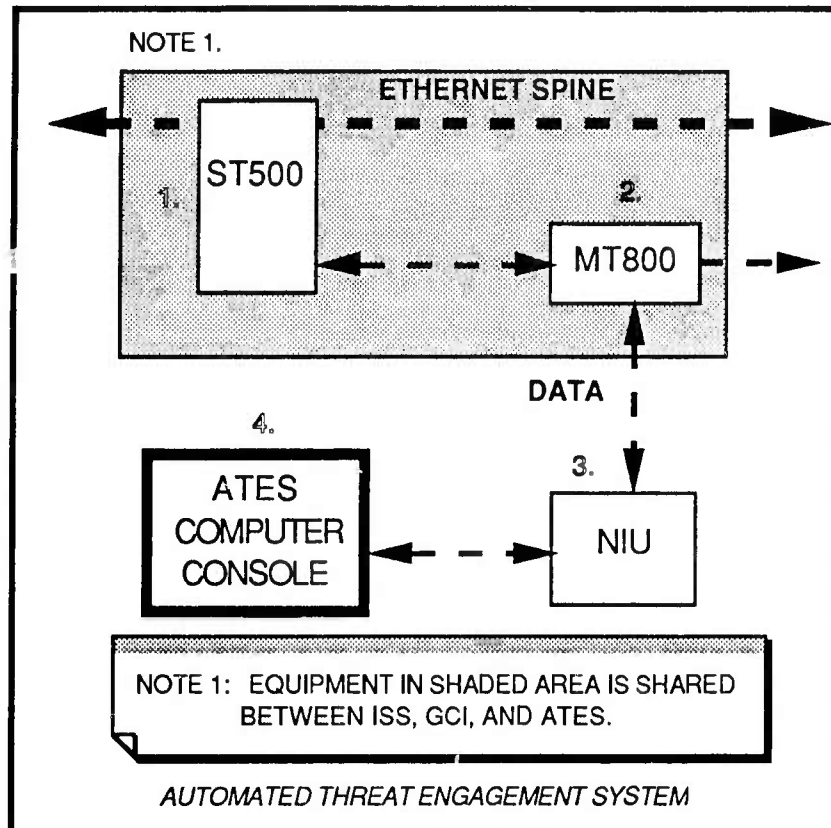

Figure 3-4. GCI Block Diagram

**3.2.1.4 ATES (Automated Threat Engagement System).**

The ATES is operational but not installed on the network. Units that make up the ATES are illustrated in Figure 3-5. The same (1) ST500 and (2) MT800 used with the ISS and GCI are employed here using other outputs of the MT800. Again, 15-pin transceiver cables are used for all interconnections shown here. The (3) NIU provides data translation only, for the (4) ATES. The ATES contains its own display. The NIU and ATES are located on the same platform area as the ISS and GCI.



**Figure 3-5. ATES Block Diagram**

**3.2.1.5 MDRC (McDonnell Douglas Reconfigurable Cockpit) Simulator.**

The equipment comprising the MDRC Simulator is shown in Figure 3-6. A (1) ST500 clamps on the Ethernet Spine, providing connection between it and (2) a MT800 Multiport Transceiver Unit via 15-pin transceiver cables. This type of cable is used for interconnections shown here, except where noted. The (3) NIU provides both voice and data translation. Output of the NIU is routed to a (4) DESTA box whose output is non-length-critical thin wire. It is then routed to another DESTA box to change back to 15-pin transceiver cable. The only reason for employing the DESTA boxes is to provide correct connector mating without using additional transceivers.

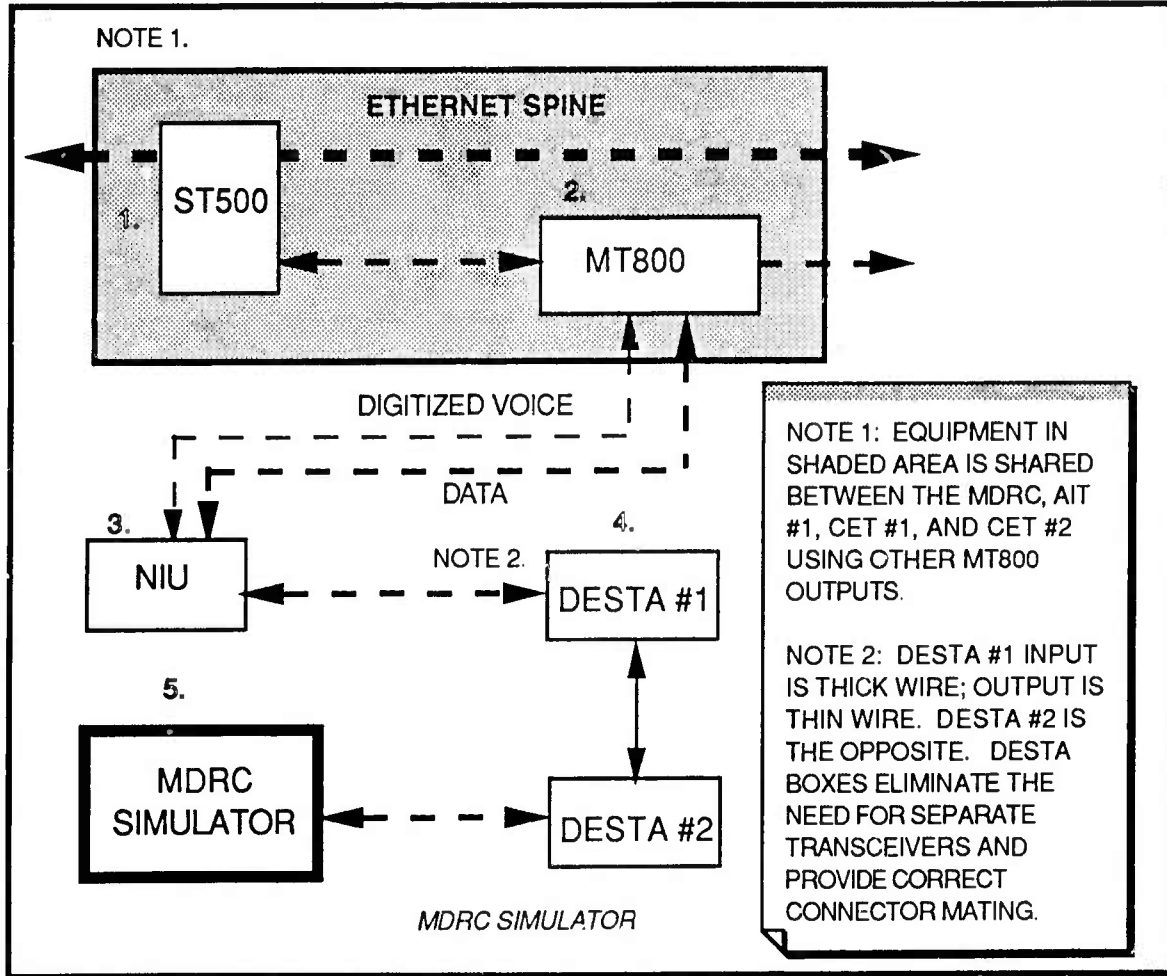

Figure 3-6. MDRC Block Diagram

**3.2.1.5 AIT (Air Intercept Trainer) Simulator**

The equipment comprising the AIT #1 Simulator is illustrated in Figure 3-5. The same (1) ST500 and (2) MT800 used with the MDRC and CET simulators is employed here using other outputs of the MT800. Again, 15-pin transceiver cables are used for interconnections shown here, except where noted. The (3) NIU, (4) AIT host computer, (5) Multi-Node tap, and (6) Visual Display are networked to form the AIT #1 Simulator. The NIU translates both voice and data. The NIU voice output is *analog* (using unshielded microphone cable) to the AIT #1 Simulator. The NIU data output is routed through a Multi-Node Tap which connects to the AIT #1 host computer and to the Visual Display.

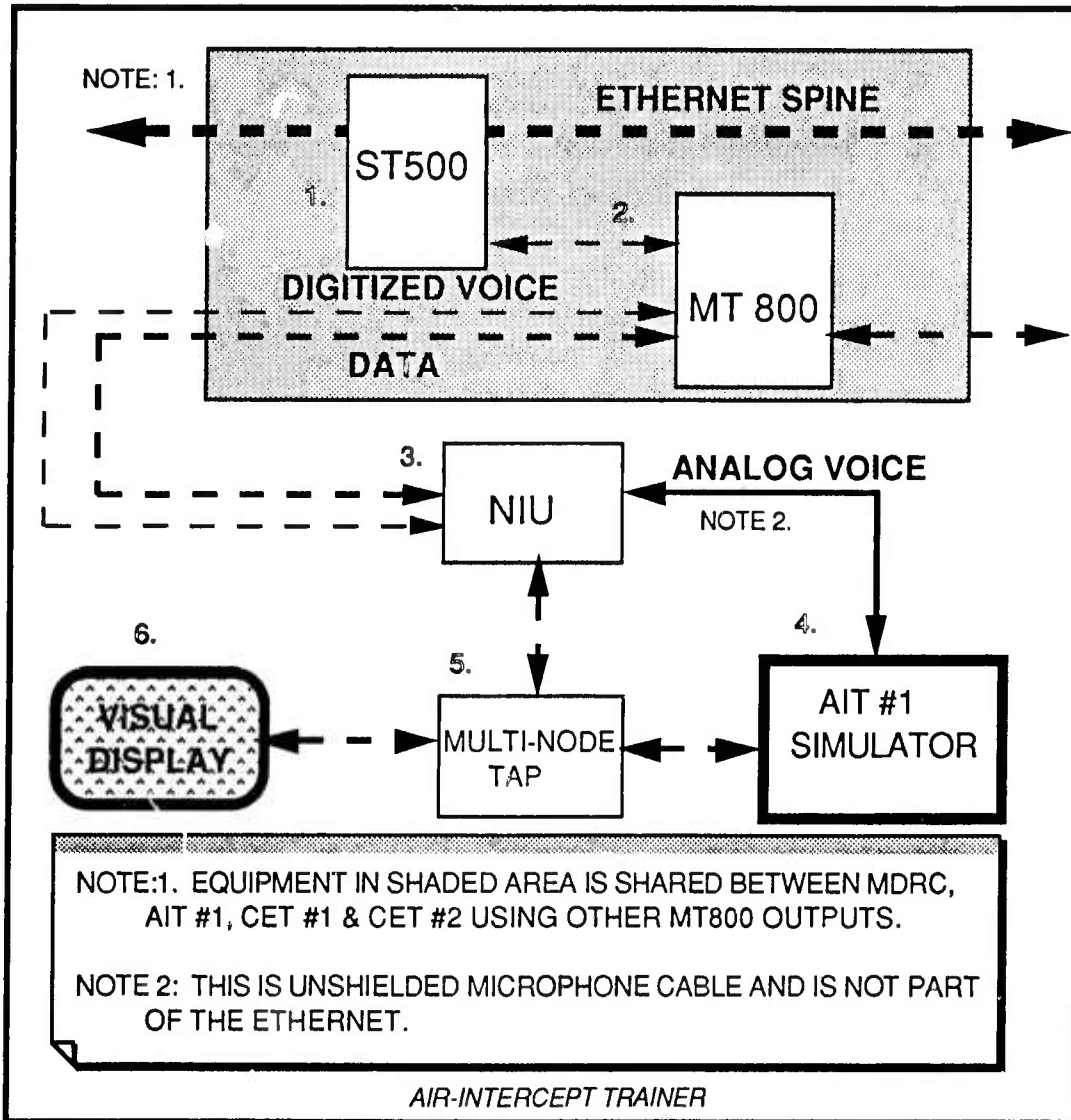

Figure 3-7. AIT #1 Block Diagram



## SECTION 4. PERFORMANCE CHARACTERISTICS

TBD