

PL-TR-91-2131

AD-A244 502



②

TRANSIENT PULSE MONITOR (TPM)

D. R. DANA

SRI International
333 Ravenswood Avenue
Menlo Park, CA 94025

DTIC
SELECTE
DEC 30 1991
S D D

November 1991

Final Report
September 1986-April 1991

APPROVED FOR PUBLIC RELEASE; DISTRIBUTION UNLIMITED



PHILLIPS LABORATORY
AIR FORCE SYSTEMS COMMAND
HANSCOM AIR FORCE BASE, MASSACHUSETTS 01731-5000

91-19177

91 1227 049

This technical report has been reviewed and is approved for publication.

PAUL S. SEVERANCE
Contract Manager

DAVID A. HARDY
Branch Chief

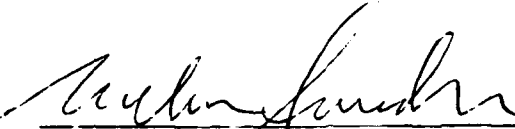
WILLIAM SWIDER
Deputy Division Director

This report has been reviewed by the ESD Public Affairs Office (PA) and is releasable to the National Technical Information Service (NTIS).

Qualified requestors may obtain additional copies from the Defense Technical Information Center. All others should apply to the National Technical Information Service.

If your address has changed, or if you wish to be removed from the mailing list, or if the addressee is no longer employed by your organization, please notify PL/IMA, Hanscom AFB, MA 01731-5000. This will assist us in maintaining a current mailing list.

Do not return copies of this report unless contractual obligations or notices on a specific document requires that it be returned.

REPORT DOCUMENTATION PAGE

Form Approved
OMB No. 0704-0188

Public reporting burden for this collection of information is estimated to average 1 hour per response, including the time for reviewing instructions, searching existing data sources, gathering and maintaining the data needed, and completing and reviewing the collection of information. Send comments regarding this burden estimate or any other aspect of this collection of information, including suggestions for reducing this burden, to Washington Headquarters Services, Directorate for Information Operations and Reports, 1215 Jefferson Davis Highway, Suite 1204, Arlington, VA 22202-4302, and to the Office of Management and Budget, Paperwork Reduction Project (0704-0188), Washington, DC 20503.

1. AGENCY USE ONLY (Leave Blank)		2. REPORT DATE November 1991	3. REPORT TYPE AND DATES COVERED Final Report (September 1986 - April 1991)	
4. TITLE AND SUBTITLE Transient Pulse Monitor (TPM)			5. FUNDING NUMBERS PE 63410F PR 2822 TA 01 WU AH Contract F19628-86-C-0231	
6. AUTHOR(S) D. R. Dana				
7. PERFORMING ORGANIZATION NAME(S) AND ADDRESS(ES) SRI International 333 Ravenswood Avenue Menlo Park, CA 94025			8. PERFORMING ORGANIZATION REPORT NUMBER	
9. SPONSORING/MONITORING AGENCY NAME(S) AND ADDRESS(ES) Phillips Laboratory Hanscom AFB, MA 01731-5000 Contract Manager: Capt. Paul Severance/GPSP			10. SPONSORING/MONITORING AGENCY REPORT NUMBER PL-TR-91-2131	
11. SUPPLEMENTARY NOTES				
12a. DISTRIBUTION/AVAILABILITY STATEMENT Approved for public release; distribution unlimited			12b. DISTRIBUTION CODE	
13. ABSTRACT (Maximum 200 words) The Transient Pulse Monitor (TPM) detects and characterizes transient electric fields and currents on satellites to help investigate arc discharge phenomena affecting spacecraft operation in various space environments. The TPM was originally developed to measure arc discharge parameters for several different experiments on a combined mission. However, in its present configuration, the TPM will be used to characterize arc discharges resulting from high-voltage solar-array operation (simulated by biasing) in the low- to medium-altitude space-plasma environment for Phillips Laboratory's Photovoltaic Array Space Power Plus Diagnostics (PASP Plus) experiment. This report describes the TPM design, the nature of its measurements, and the results of the calibration and environmental testing of the instrument in its flight configuration as part of the PASP Plus experiment.				
14. SUBJECT TERMS (U) Transient Pulse Monitor [TPM], (U) electrical transient sensor, (U) arc pulse parameter measurements, (U) arc discharge characterization			15. NUMBER OF PAGES 80	
			16. PRICE CODE	
17. SECURITY CLASSIFICATION OF REPORT UNCLASSIFIED	18. SECURITY CLASSIFICATION OF THIS PAGE UNCLASSIFIED	19. SECURITY CLASSIFICATION OF ABSTRACT UNCLASSIFIED	20. LIMITATION OF ABSTRACT SAR	

ACKNOWLEDGMENTS

We are grateful to Captain Paul Severance, Dr. Donald Guidice, and Mr. David Pendleton for their around-the-clock assistance in the completion of the environmental tests at Phillips Laboratory (PL).

Accession For	
NTIS CRA&I	<input checked="" type="checkbox"/>
DTIC TAB	<input type="checkbox"/>
Unannounced	<input type="checkbox"/>
Justification	
By	
Distribution/	
Availability Codes	
Dist	Availability Code Special
A-1	



CONTENTS

ACKNOWLEDGMENTS	iii
CONTENTS	v
FIGURES	vii
TABLES	viii
ACRONYMS	ix
1 INTRODUCTION	1
1.1 Purpose of the TPM.....	1
1.2 Historical Background.....	1
1.3 Scope of this Report.....	2
2 TECHNICAL EFFORT	3
2.1 Design	3
2.2 Assembly	3
2.3 Component Failures.....	6
2.4 Calibration	7
2.4.1 Pulse Analyzers.....	7
2.4.1.1 Procedure	7
2.4.1.2 Typical Responses.....	11
2.4.1.3 Data Reduction.....	15
2.4.1.4 Results	15
2.4.2 Electric-Field Sensors.....	15
2.4.2.1 Background	15
2.4.2.2 Results	17
2.4.3 Current Sensor	17
2.4.3.1 Background	17
2.4.3.2 Results	17
3 ENVIRONMENTAL TESTS	21
3.1 Goals	21
3.2 Overall Procedure.....	21
3.3 Equipment and Configuration.....	23

3.4	Thermal Vacuum Tests	24
3.4.1	Facilities.....	24
3.4.2	Test Limits	24
3.4.3.	TPM Configuration.....	24
3.4.4	Procedures	27
3.4.5	Thermal Considerations	28
3.4.6	Results.....	28
3.4.6.1	Low Temperature	29
3.4.6.2	High Temperature.....	33
3.4.6.3	Low versus Room Temperature	38
3.4.6.4	High versus Room Temperature	38
3.4.6.5	High-Temperature Leakage Errors.....	38
3.5	Random Vibration Tests.....	42
3.5.1	Facilities.....	42
3.5.2	Test Limits	42
3.5.3	TPM Configuration.....	42
3.5.4	Procedure.....	42
3.5.5	Results.....	44
3.6	Summary	47
4	INTEGRATION CONSIDERATIONS	49
4.1	Electromagnetic Compatibility	49
4.2	Electric-Field Sensor Placement	49
4.3	Channel Priorities	50
4.4	Radiation Susceptibility	50
4.5	Electric-Field Sensor Grounding	51
4.6	Preflight Testing.....	51
5	CONCLUSIONS.....	55
	APPENDIX CALIBRATION RESULTS.....	A-1

FIGURES

1	TPM Central Processor	4
2	TPM Sensors	5
3	Calibration Setup	8
4	Constant-Pulse-Shape Family	8
5	Constant-Parameter Pulse Families	9
6	Typical Amplitude Detector Response	12
7	Typical Derivative Detector Response	13
8	Typical Integral Detector Response	14
9	Typical Calibration Curve	16
10	Relative Gain of Current Sensor	19
11	TPM and GSE in Vacuum Chamber Laboratory	25
12	Electric-Field Stimulus Used in Vacuum Test	26
14	Channel 2 Integral History	37
15	TPM Installed on Shake Table	43
16	Random Vibration Spectrum	45

TABLES

1	Calibration History.....	10
2	Electric-Field Sensor Calibrations.....	18
3	Environmental Test Data Sets.....	22
4	Average Outputs at Low Temperatures.....	30
5	Standard Deviations at Low Temperatures.....	31
6	Peak-to-Peak Deviations at Low Temperatures.....	32
7	History of Suspect Parameters.....	33
8	Average Outputs at High Temperatures.....	34
9	Standard Deviations at High Temperatures.....	35
10	Peak-to-Peak Deviations at High Temperatures.....	36
11	Channel 2 Integral History.....	37
12	Average Change from 25°C to 8°C.....	39
13	Average Change from 25°C to 75°C.....	39
14	High-Temperature Leakage.....	41
15	Cumulative Changes in Response.....	46
16	Channels Rated by Leakage.....	52
17	Recommended Channel Priorities.....	52
18	Room-Temperature Functional Test Results.....	53

ACRONYMS

GSE	Ground Support Equipment
IMPS	Interaction Measurement Payload for Shuttle
PASP	Photovoltaic Array Space Power
PL	Phillips Laboratory
TPM	Transient Pulse Monitor

1 INTRODUCTION

1.1 PURPOSE OF THE TPM

The Transient Pulse Monitor (TPM) developed under contract F19628-86-C-0231 detects and characterizes transient currents and electric fields on satellites for the purpose of studying electrostatic discharges. As a diagnostic tool for the Photovoltaic Array Space Power (PASP) Plus experiment, which studies the long-term performance and environmental interactions of high-voltage solar arrays, it will reveal the severity and frequency of discharges that may result from high-voltage operation. The TPM is also well-suited to measure discharges that may result from environmental interactions, unrelated to the high-voltage arrays, that are known to affect all spacecraft.

The TPM has two types of sensors: one that measures currents conducted on a wire, and another that measures electric fields. Both sensor types are optimized to measure pulses of a few nanoseconds to a few microseconds in duration, which includes the range expected to result from spacecraft discharges. For the PASP-Plus experiment, the TPM has been configured with one current sensor and five electric-field sensors. The current sensor will measure transients on the output of the high-voltage power supply that is used to bias the solar cells. The electric-field sensors will be located near the solar cells to detect discharges in their vicinity.

The TPM characterizes pulses in a way fundamentally different from that of transient digitizers. It uses analog circuitry to derive key parameters of transients—peak amplitude, peak derivative, and integrated magnitude—in real time. This approach has several advantages over transient digitizers: The circuitry is more compact, consumes much less power, has wide dynamic range, and rivals the state of the art in bandwidth. Finally, it produces data that are almost immediately usable for engineering analysis of transient characteristics.

1.2 HISTORICAL BACKGROUND

The TPM was originally intended to measure arc-discharge parameters for several different kinds of experiments on the Interactions Mass Payload for Shuttle (IMPS) mission. This payload was to be deployed from the Shuttle bay, put into nearby space, and then retrieved several days later. The IMPS experiments included a Space-Based Radar Antenna experiment, a Surface Potential Measurement experiment, and the Photovoltaic Array Space Power (PASP) experiment.

After the Challenger disaster, it became necessary to fly IMPS's technology experiments separately. Because of funding and other limitations, only the PASP experiment was developed to the point where it could seek a suitable spaceflight. Since it was no longer part of IMPS, PASP needed to have its own environmental sensors and thus became PASP Plus Diagnostics (PASP Plus for short). The TPM will be used to characterize arc discharges resulting from high-voltage solar-array operation (simulated by array biasing) in the low- to medium-altitude space plasma environment. The carrier eventually obtained for PASP Plus was a long-term flight (one to three years) on a non-retrievable satellite (Pegastar) placed into an elliptical orbit by Pegasus, a multistage rocket air-launched from a B-52.

The TPM, originally intended for very-short-term operation (several days), will now have to operate over many months during the high-voltage biasing portion of the PASP Plus flight. With Pegastar's orbit passing through the lower portion of the earth's inner radiation belt and the extension of the TPM's operation's lifetime out to many months, the TPM's susceptibility to space radiation becomes an issue. Increased shielding around the TPM electronics box can be used to minimize the susceptibility.

1.3 SCOPE OF THIS REPORT

This report describes the TPM as an instrument for the PASP Plus experiment. It emphasizes the changes in the TPM's status since the second interim technical report.* At the time of that report, the TPM design was essentially complete, and the TPM flight unit had undergone its first assembled tests. During the third and last reporting period, we thoroughly tested and calibrated the assembled TPM system, and packaged it in a flight configuration.

* Dana, D. R., "Transient Pulse Monitor," Scientific Report No. 2, GL-TR-89-0305, Geophysics Laboratory, Hanscom AFB, MA, 27 October 1989, ADA220353.

2 TECHNICAL EFFORT

2.1 DESIGN

Only one design change was made to the TPM beyond the design described in Scientific Report No. 2. After assembly of the circuit boards, we discovered excessive decrease in the TPM outputs at high temperatures. This decrease was caused by leakage in the sample-and-hold circuit at the output of each TPM pulse analyzer (each board has five such circuits for a total of 30 in the TPM). By far the largest source of leakage in the circuit was a small-signal diode, whose reverse leakage current approximately doubled for each 10°C increase in temperature. The design already included a circuit to compensate for this leakage, but a change in resistor values was required to increase this compensation to a level appropriate for the temperatures expected. We made this change on all the boards before conformally coating them. Some residual leakage persists at the higher temperatures (Section 3.4.6.5), but this change reduced it to the minimum practical value.

2.2 ASSEMBLY

After thoroughly testing the assembled TPM, we disassembled it to conformally coat all the circuit boards. We applied Solithane 113 using the hand-applied process specified in the Interaction Measurement Payload for Shuttle (IMPS) Procedures and Requirement Document, Appendix E-4.

Figure 1 shows the TPM central processor before installation of the front wall and cover. The bottom pulse analyzer board (one of six) is drawn out to illustrate the slide-in mounting arrangement. Below this board (not visible) is the digital processor board. After the front wall is mounted, each board is secured with brackets on both its front and back edges. The power-conditioning circuitry is mounted vertically in the compartment to the left of the main circuit boards. Mounting brackets on all four edges of the board provide both mechanical strength for the heavy components and thermal conduction to the outer wall and baseplate.

Figure 2 shows an electric-field sensor (the larger of the two) and the current sensor. The plate mounted on top of the electric-field sensor housing is the actual antenna element, separated from the housing by a thin dielectric layer.

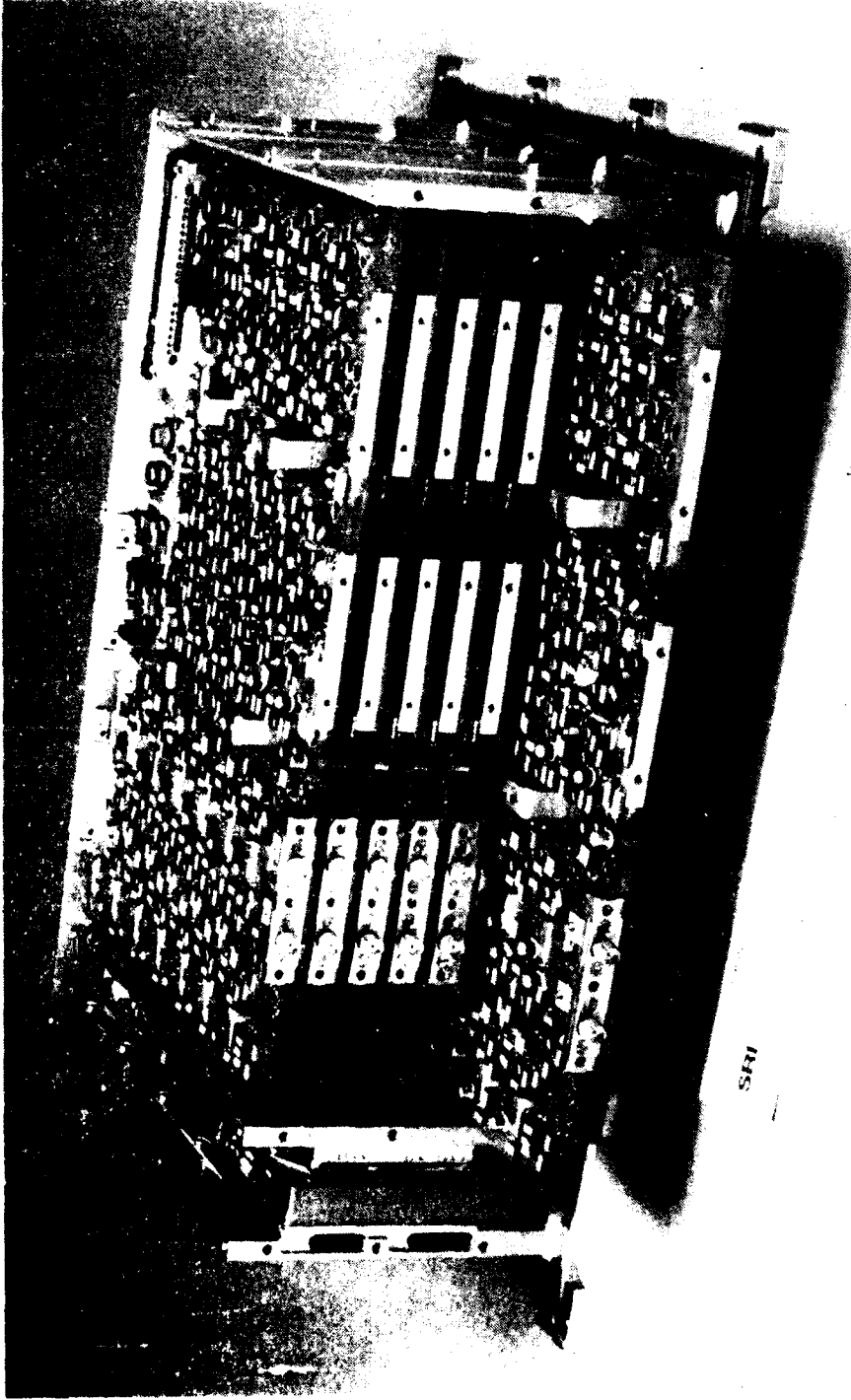

2726/r-11

Figure 1. TPM Central Processor.

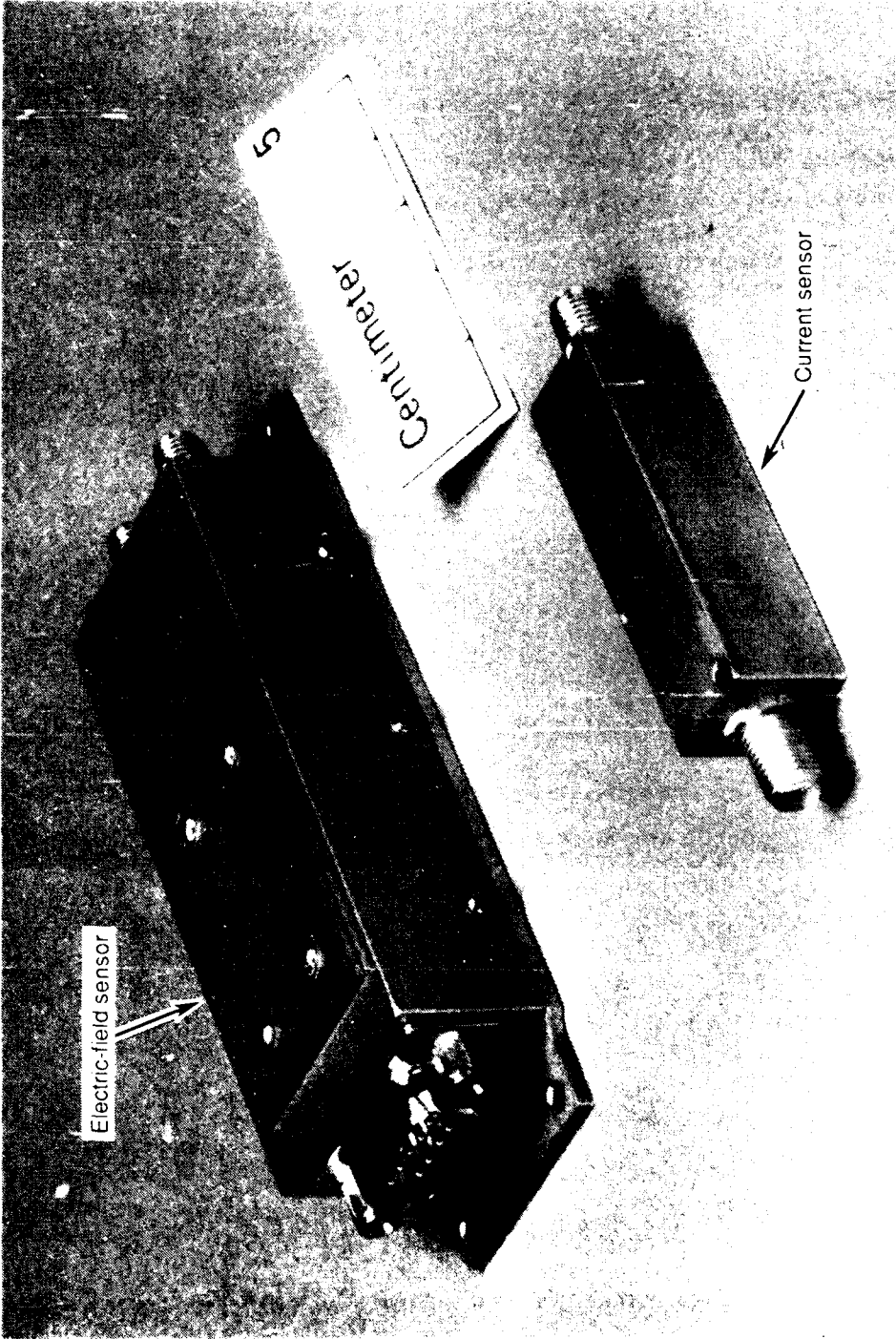

2726tr.12

Figure 2. TPM Sensors.

2.3 COMPONENT FAILURES

After initial assembly of the pulse analyzer circuit boards, we found a total of three failed components on three different boards. The first two appeared shortly after the boards were assembled and subjected to their first temperature cycle. The third appeared after we applied conformal coating to the boards.

The first failure involved a 2N918JTXV transistor, of which the TPM has 120, in the integrator portion of Board 2. The behavior of this transistor suggested that the internal connection from its emitter to the corresponding lead had opened. This is a common temperature-related failure for transistors. After replacement of this transistor, the circuit behaved normally.

The second failure involved a 2N4261JTX transistor, of which the TPM has 136, in the integrator portion of Board 7. This transistor's base connection seems to have failed in a manner similar to the previous failure. This circuit has also behaved normally since the replacement of the faulty transistor.

The third failure was that of a 1N5711JTXV diode, of which the TPM has 159, in the integrator portion of Board 3. Unlike the previous two, this failure was intermittent, appearing only at high temperatures. This, and the fact that it appeared after the boards had been coated, made it difficult to troubleshoot; but eventually we discovered a tiny crack in the glass case of the diode. Thermal stresses associated with the conformal coating apparently caused the diode to open at high temperatures (once we located the faulty diode we found the failure could be duplicated at any temperature by application of a small direct pressure). We cannot know whether the coating exacerbated a crack that was inflicted during the diode's original installation (or earlier), or whether application of the coating actually caused the crack. We observed no similar problems in any other circuit, nor in this circuit after the diode was replaced and the coating in its vicinity reapplied.

The fact that these three failures all occurred in integrator circuits initially seemed suspicious, but after carefully examining the design of that circuit, we concluded that it was a coincidence. In particular, the diode failure was essentially mechanical and could not have been caused by any fault in the circuitry to which it was connected. The transistors failed in a way typical of marginal components and cannot be attributed to any normal circuit stresses. For example, the transistors are rated to operate with collector-emitter voltages as high as 15 V, while in this circuit the voltage ranges from a steady-state value of less than 3 V to a peak pulsed value of less than 6 V. Similarly, their power dissipation is approximately 1.5 mW, compared with a rating of 200 mW.

2.4 CALIBRATION

2.4.1 Pulse Analyzers

2.4.1.1 Procedure

Since the TPM is designed to measure a very wide range of inputs, we developed an automated calibration system (**Figure 3**). A computer directs a programmable pulse generator to produce pulses of various amplitudes, rise times, and fall times and records the TPM's response to each pulse shape. The data can then be processed to show the response of each pulse analyzer circuit to variations in the applicable parameter.

The calibration program sets the pulse generator to produce triangular pulses with constant rise and fall times while the amplitude is varied (**Figure 4**). Since the peak amplitude, peak derivative, and pulse integral all vary proportionally with the pulse amplitude, this process generates a complete family of responses in each parameter channel as a function of amplitude.

Although one family of constant-pulse-shape pulses gives a complete calibration response for each parameter, many families of constant-pulse-shape responses can be recorded. These data can then be arranged to correspond to families of constant-parameter inputs (**Figure 5**). For example, various combinations of pulse duration and peak amplitude can result in the same value of integral. Ideally, the TPM integral channel would respond identically to all these pulses. Its deviation from this ideal can be assessed using the automated process described.

For the TPM flight unit, each calibration consisted of 228 different combinations of pulse amplitude and duration: amplitudes ranging over 54 dB in 3 dB steps, and durations ranging over 60 dB in 6 dB steps. All the pulses were triangular, with equal rise and fall times ranging from 5 ns to 5 μ s. All these combinations were repeated for both pulse polarities. We performed calibrations at several temperatures and at several stages during the TPM assembly to verify proper operation (**Table 1**). This allowed us to uncover several component failures (Section 2.3).

In **Table 1**, and whenever we refer to specific TPM channels, it is important to note the distinction between channel numbers and board numbers. The boards were assigned serial numbers 1 through 7 at the time of assembly. The channel numbers 0 through 5 indicate physical slots in the central processor, into which any board can be inserted (the channels are numbered sequentially, with the lowermost numbered 0). **Table 1** indicates two different assignments of boards to slots. Initially we assigned them sequentially, with Board 7 as spare (indicated as channel "S" in the table). After the first set of tests showed a slight inconsistency in the performance of Board 4, we replaced it with Board 7 and kept Board 4 as the spare.

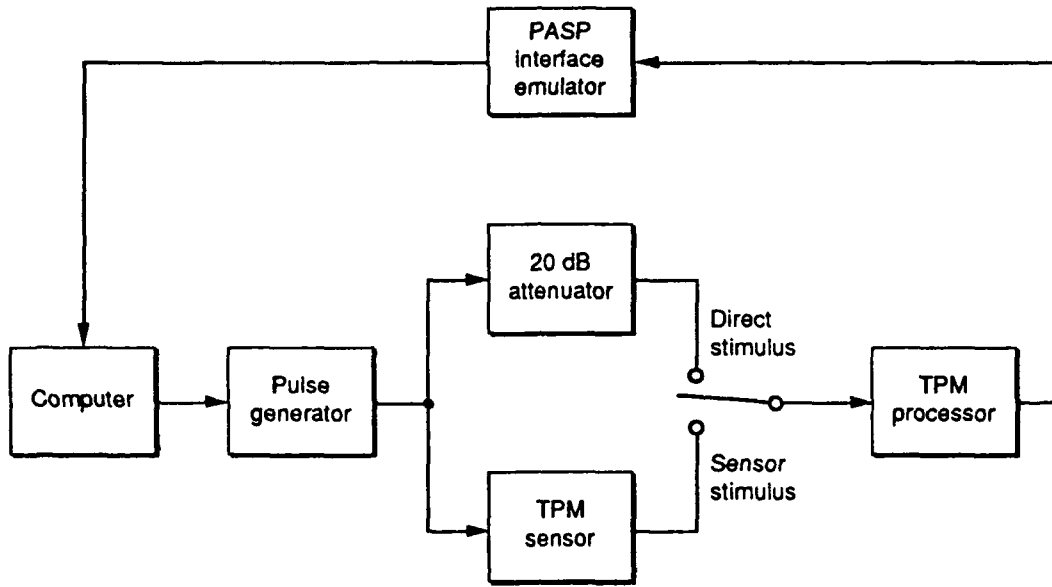

27261r/13

Figure 3. Calibration Setup.

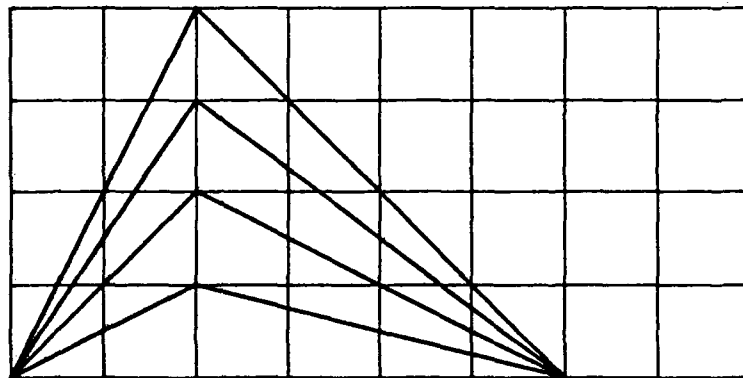

27261r/110

Figure 4. Constant-Pulse-Shape Family.

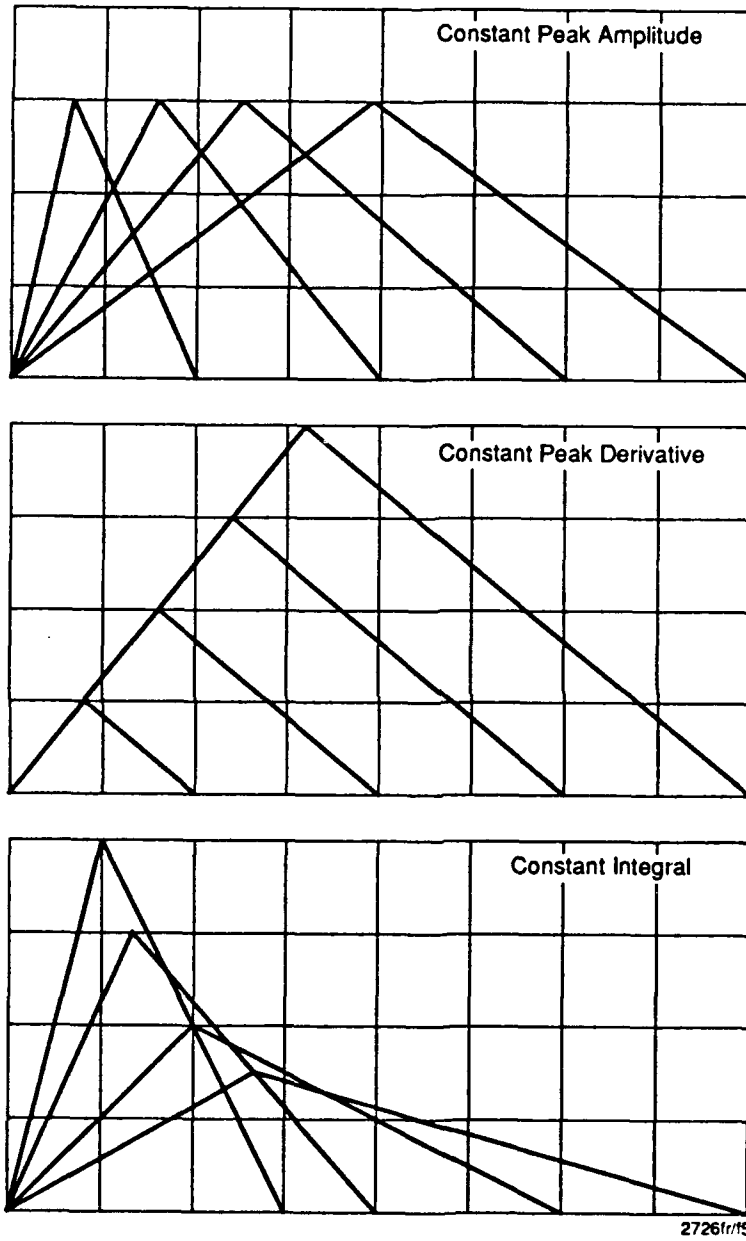

Figure 5. Constant-Parameter Pulse Families.

Table 1

CALIBRATION HISTORY

1980	Low Temperature							Room Temperature							High Temperature							Sensors?	COMMENTS
	0	1	2	3	4	5	S	0	1	2	3	4	5	S	0	1	2	3	4	5	S		
Channel→	0	1	2	3	4	5	S	0	1	2	3	4	5	S	0	1	2	3	4	5	S		
Board→	1	2	3	4	5	6	7	1	2	3	4	5	6	7	1	2	3	4	5	6	7		
Jan 11																						Yes	
Jan 12								*	±	±	±	±	±									Yes	* With and without sensor
Jan 16								±	±	±	±	±	±									Yes	
Jan 19								+														Yes	Test of ungrounded sensor
Jan 24														*	±							Yes	* Fix of bad transistor in Board 7 integrator
Jan 30														*							*	Yes	* Test of high-temp leakage comp
Feb 6								*	±	±	±	±	±										* Leakage compensation installed
Feb 8															±	±	±	±	±	±			
Feb 9	±	±	±	±	±	±																	
Feb 11								±	±	±	*	±	±										
Feb 12														±							±		* Shift in Channel 3 PDER
Feb 13	±	±	±	±	±	±	±							±									Primarily to test Boards 4 and 7
Channel→	0	1	2	3	4	5	S	0	1	2	3	4	5	S	0	1	2	3	4	5	S		Primarily to test Boards 4 and 7
Board→	1	2	3	7	5	6	4	1	2	3	7	5	6	4	1	2	3	7	5	6	4		Board 4 replaced by Board 7
Feb 17								±	±	±	±	±	±									Yes	All installed boards conformally coated
Feb 19	±	±	±	±	±	±		±	±	±	±	±	±		±	±	±	±	±	±		Yes	
Feb 20	±	±	±	±	±	±		±	±	±	±	±	±		±	±	±	±	±	±		Yes	Witnessed by Guidice and Severance
Feb 23								*							*							Yes	* Diagnose temperature problem with Board 3
May 17								±							±								Checkout after repair of Board 3 integrator
May 25																							
May 29																							
May 30																							
June 7	±							±							±							Yes	With sensor
June 13								±	±	±	±	±	±		±	±	±	±	±	±		Yes	Complete system with sensors
June 14	±	±	±	±	±	±	±	±	±	±	±	±	±		±	±	±	±	±	±		Yes	All ungrounded; "c" files @ -10°C; "h" files @ 72°C
June 15	±	±	±	±	±	±	±															Yes	"c" files @ 10°C; "c2" @ 0°C
June 19															±	±	±	±	±	±		Yes	"h1" files @ 40°C; "h2" files @ 56°C

The calibration setup can either directly stimulate the pulse analyzer inputs or do so through the electric-field or current sensors. After assembly, all calibrations not related to an individual board repair, except for Channel 5 (as explained below), included the sensors. We consistently assigned electric-field Sensors 1 through 5 sequentially to Channels 0 through 4. The current sensor was always assigned to Channel 5. Because the current sensor is less sensitive than the electric-field sensors, the pulse generator could not provide large enough signals to test the full-scale response of Channel 5 while exciting the current sensor. Therefore, many calibrations of Channel 5 were performed with both direct stimulation and current sensor stimulation. Some were performed with only direct stimulation, once we had determined the response of the current sensor itself.

2.4.1.2 Typical Responses

Figure 6 shows the peak amplitude detector response of a typical TPM channel. The X axis represents the logarithm of peak input amplitude (decibels relative to 1 V calculated as $20 * \log_{10}[\text{input}]$), and the Y axis shows the TPM's digitized output (full-scale output is 255). An individual curve on the graph represents the response to a constant-pulse-shape family of triangular pulses with varying amplitude. The composite set of curves represents the TPM response to pulse inputs ranging from 10 ns to 10 μ s. In actual measurements, the pulse length will be unknown, so the differences between these curves represent an uncertainty factor in the amplitude measurement. For pulses over the full range of widths and amplitudes, this uncertainty is less than 3 dB. In practice, the pulse-to-pulse variation will likely be lower, because the range of pulsewidths generated by electrostatic discharges is more typically 100 ns to 1 μ s.

To produce calibration curves that can be used to map TPM digital outputs to input pulse amplitudes, we produced a composite curve that represents the average of all the curves shown. We did this by averaging the output values corresponding to inputs with the same peak amplitude (but varying pulse length).

Figure 7 shows the peak derivative detector response of a typical TPM channel. The X axis represents the logarithm of peak input derivative (decibels relative to 1 V/s), and the Y axis shows the TPM's digital output. The derivative channel of the TPM is less sensitive to pulsewidth than the amplitude channel, so its deviation over the range of widths is less than 2 dB.

Figure 8 shows the integral detector response of a typical TPM channel. The X axis represents the logarithm of the integrated magnitude (decibels relative to 1 Vs), and the Y axis shows the TPM's digital output. The deviation in readings for identical integral inputs is approximately 2 dB, over the pulsewidth range of 10 ns to 5 μ s. Like all the pulse analyzers, the

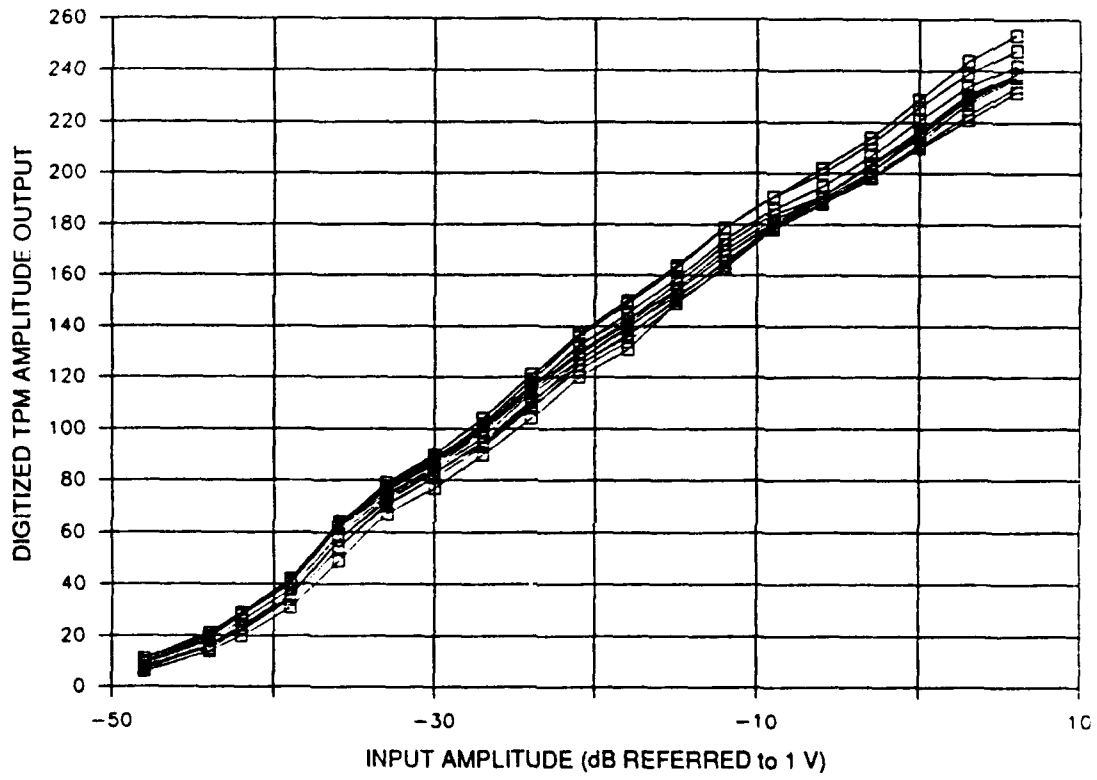

2726tr2/12

Figure 6. Typical Amplitude Detector Response.

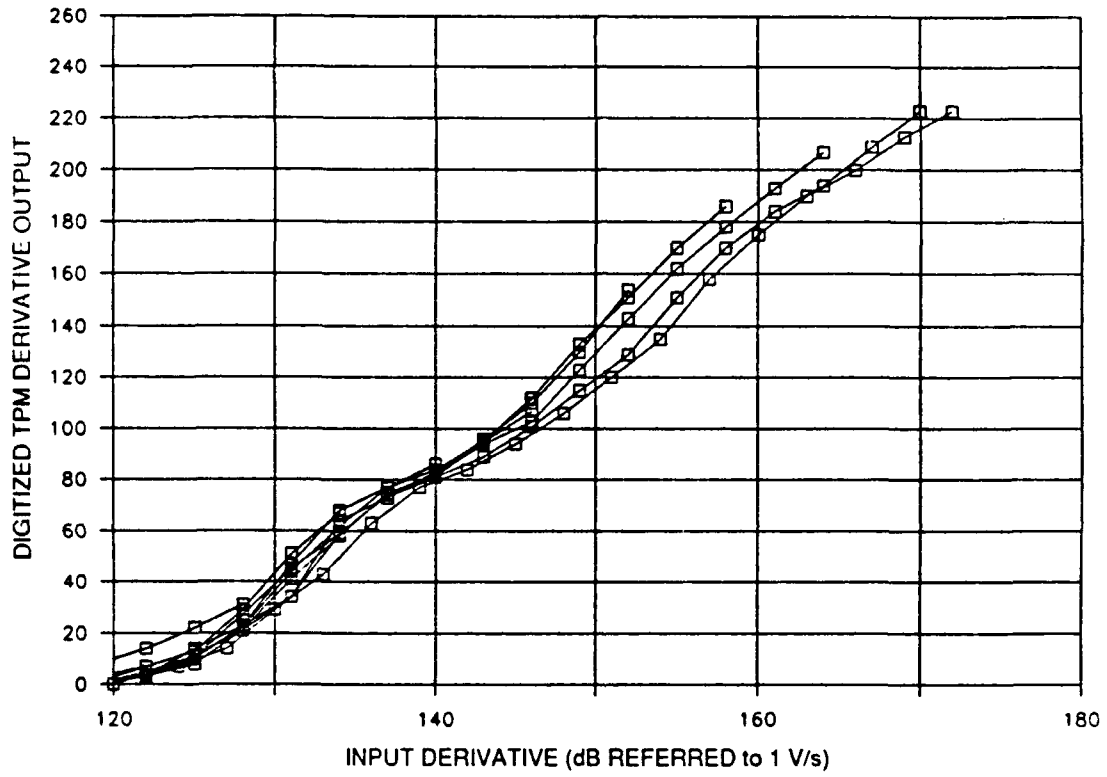

2726:tr2/113

Figure 7. Typical Derivative Detector Response.

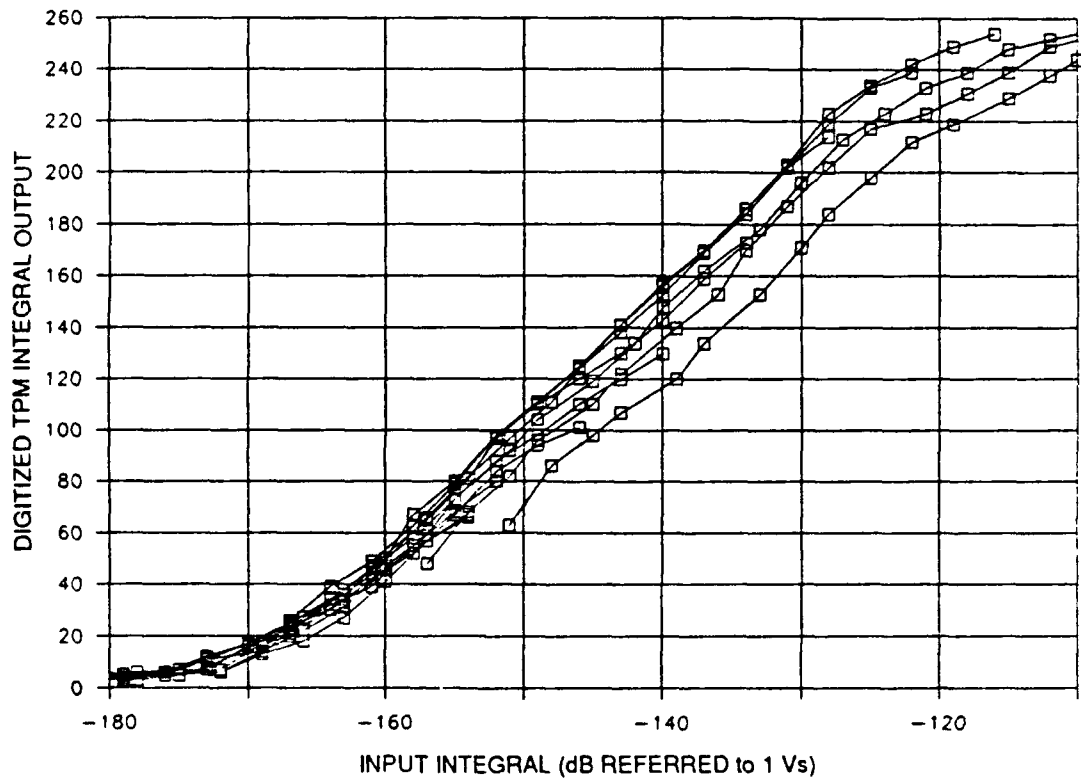

2726r2/114

Figure 8. Typical Integral Detector Response.

integral channel rejects very long pulses that are not likely to result from static discharges. The lowest curve on the graph represents the response to a triangular pulse with 20 μs duration measured at the base.

2.4.1.3 Data Reduction

To use the calibration data during flight operations requires reducing families of output-versus-input curves to individual curves of estimated input versus TPM output. We did this by arranging the data into constant-parameter families and averaging the responses at each parameter value. For example, consider a simplified calibration in which pulse amplitudes include 1 V, 0.1 V, and 0.01 V, and pulse durations include 1 μs , 0.1 μs , and 0.01 μs . The longest, largest pulse has an integral of 1 μVs ; the shortest, smallest has an integral of 0.1 nVs. Integral values between these extremes are represented by more than one pulse combination. Integrals of 0.01 μVs are produced by three different combinations: 1 V \times 0.01 μs , 0.1 V \times 0.1 μs , and 0.01 V \times 1 μs . To produce the final calibration point for this value of integral, we would average the TPM integral analyzer's response to these three input pulses. The TPM calibrations, with 19 values of amplitude and 11 values of pulsewidth, results in many more combinations.

Figure 9 shows a typical integral curve generated by this method, superimposed on the complete data set for illustration.

2.4.1.4 Results

The calibration data for each channel at various temperatures are presented in the appendix.

2.4.2 Electric-Field Sensors

2.4.2.1 Background

To calibrate the electric-field sensors, we applied a known field to each sensor and noted the corresponding TPM output. Using the pulse analyzer calibration data, we then found the input voltage that produced the same output when applied directly to the pulse analyzer input. This made it possible to calculate a constant of proportionality between applied field and equivalent TPM input voltage, which provided an absolute calibration in terms of electric field.

We generated a known field by applying a voltage between a pair of parallel conducting plates. The field between these plates was equal to V/d , where V is the voltage and d is the distance between the plates. Inserting the conductive sensor between the plates perturbed the field in its vicinity, but if the size and spacing of the plates are large compared with the sensor, they

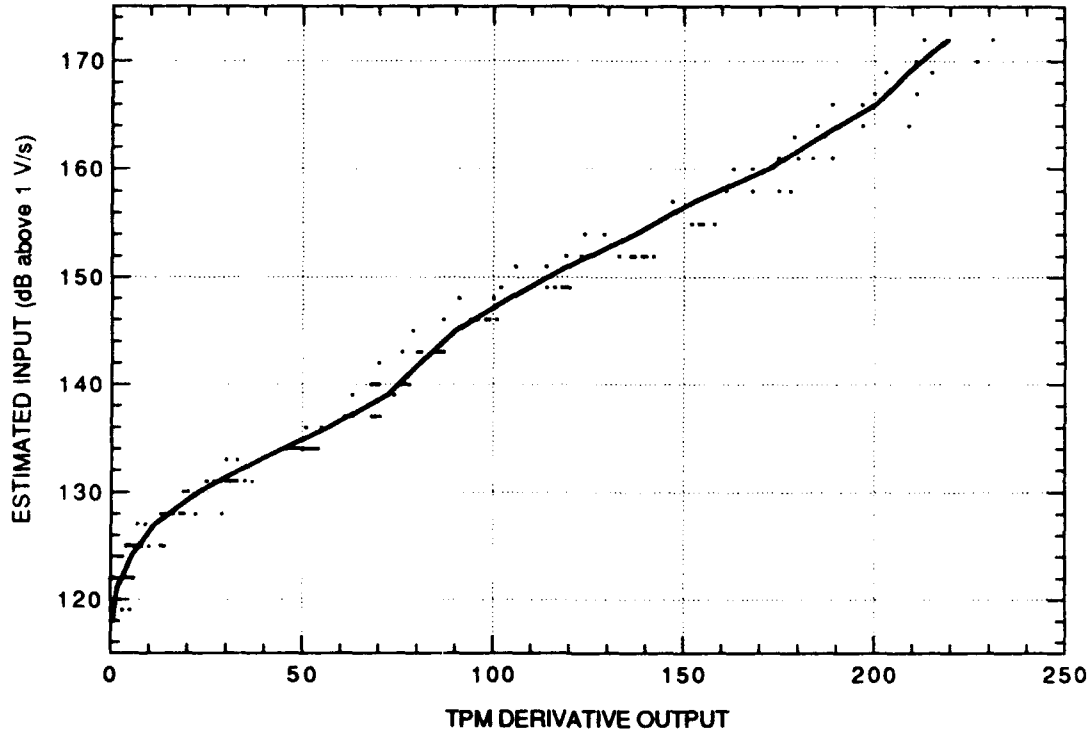

27261r/19

Figure 9. Typical Calibration Curve.

approximately duplicate a free field. We used one-meter square plates and measured each sensor's response with plate separations of 16.8 cm and 21.7 cm, the latter being about ten times the height of the sensors. There is a tradeoff in plate separation between accuracy of the simulation and signal-to-noise ratio. The pulse generator in this setup was limited to 20 V pulses, so that the peak field within the plates was in the order of 100 V/m. Much larger plate separations would have resulted in inadequate signals.

This parallel-plate setup produces accurate fields only under quasi-static conditions. High-frequency signals can be distorted by reflections and resonances of the square plates (the plates are one-half wavelength wide at roughly 150 MHz). Therefore, we had to carefully choose pulsewidths long enough to avoid this distortion. It was also necessary to use one of the same waveforms used in the pulse analyzer calibration, so that we could make a direct correlation and find the proportionality between them. We used two different waveforms for each sensor: one with 5 μ s rise and fall times (the longest pulse used in the pulse analyzer calibration), and one with 629 ns rise and fall times (the shortest that did not suffer significant distortion).

2.4.2.2 Results

We express gain of the electric-field sensors as equivalent height h , calculated as

$$h = V/E$$

where V is the equivalent output voltage (as measured at the TPM input) and E is the applied electric field in volts/meter. Equivalent output voltage is the voltage that, when applied directly to the pulse analyzer input during calibration, produces the same TPM output as observed during the sensor calibration. Since the calibration curves are sampled at a number of discrete voltages, it is in general necessary to interpolate between them to find the equivalent voltage.

Table 2 shows the complete calibration data and the equivalent heights calculated from them.

2.4.3 Current Sensor

2.4.3.1 Background

In a manner similar to the electric-field sensors, we calibrated the current sensor by correlating the TPM response to a known current through the sensor, and to a voltage applied without the sensor. We generated a calibration current by terminating the signal from the pulse generator in a 50Ω resistor, one lead of which was passed through the measurement aperture of the sensor. The current thus generated was equal to the voltage divided by 50Ω .

2.4.3.2 Results

Figure 10 shows the Channel 5 amplitude response with direct stimulus and with current sensor stimulus. Straight lines fitted to the curves are included to demonstrate that they have identical slopes. In fact, the two curves are virtually identical in shape. This indicates that the introduction of the current sensor simply introduces a linear gain factor. The difference in input amplitude values that produce a given output (100 in **Figure 10**, but identical elsewhere) indicates a difference in gains of 11.1 dB. An additional 20 dB difference, due to an attenuator used in the direct stimulus measurements, was excluded for purposes of illustration. Accounting for the effect of the 20 dB attenuator, the relationship between the voltage V_i across the 50Ω current loop and the output voltage V_o of the sensor (as applied to the TPM input) is

$$V_o = V_i \times 10^{(-31.1 \text{ dB}/20)} = V_i/35.9.$$

We also know that the current I through the sensor is

$$I = V_i/50 \Omega.$$

Then we can calculate the transfer impedance Z of the sensor by

$$Z = V_o/I = 50 \Omega \times V_o/V_i = 50 \Omega/35.9 = 1.39 \Omega.$$

Table 2
ELECTRIC-FIELD SENSOR CALIBRATIONS

Sensor	Channel	Height (m)	E (V/m)	Rise (μ s)	Polarity	TPM Out	Equiv. V	h (m)
5	4	0.168	119	5.00	+	75	0.050	4.2E-4
5	4	0.168	119	5.00	-	83	0.051	4.3E-4
5	4	0.168	119	0.63	+	71	0.048	4.0E-4
5	4	0.168	119	0.63	-	79	0.048	4.0E-4
5	4	0.217	92.2	5.00	+	68	0.042	4.5E-4
5	4	0.217	92.2	5.00	-	75	0.041	4.4E-4
5	4	0.217	92.2	0.63	+	64	0.040	4.3E-4
5	4	0.217	92.2	0.63	-	72	0.038	4.2E-4
Average								4.2E-4
4	3	0.168	119	5.00	+	77	0.055	4.7E-4
4	3	0.168	119	5.00	-	81	0.058	4.9E-4
4	3	0.168	119	0.63	+	74	0.051	4.3E-4
4	3	0.168	119	0.63	-	77	0.052	4.4E-4
4	3	0.217	92.2	5.00	+	68	0.044	4.8E-4
4	3	0.217	92.2	5.00	-	72	0.046	5.0E-4
4	3	0.217	92.2	0.63	+	67	0.042	4.6E-4
4	3	0.217	92.2	0.63	-	70	0.043	4.7E-4
Average								4.7E-4
3	2	0.168	119	5.00	+	72	0.050	4.2E-4
3	2	0.168	119	5.00	-	84	0.054	4.6E-4
3	2	0.168	119	0.63	+	70	0.048	4.0E-4
3	2	0.168	119	0.63	-	79	0.050	4.2E-4
3	2	0.217	92.2	5.00	+	65	0.040	4.3E-4
3	2	0.217	92.2	5.00	-	76	0.042	4.6E-4
3	2	0.217	92.2	0.63	+	64	0.038	4.2E-4
3	2	0.217	92.2	0.63	-	71	0.039	4.3E-4
Average								4.3E-4
2	1	0.168	119	5.00	+	72	0.051	4.3E-4
2	1	0.168	119	5.00	-	71	0.051	4.3E-4
2	1	0.168	119	0.63	+	68	0.048	4.1E-4
2	1	0.168	119	0.63	-	69	0.050	4.2E-4
2	1	0.217	92.2	5.00	+	65	0.041	4.5E-4
2	1	0.217	92.2	5.00	-	64	0.040	4.4E-4
2	1	0.217	92.2	0.63	+	62	0.039	4.3E-4
2	1	0.217	92.2	0.63	-	62	0.038	4.2E-4
Average								4.3E-4
1	0	0.168	119	5.00	+	83	0.051	4.3E-4
1	0	0.168	119	5.00	-	79	0.055	4.6E-4
1	0	0.168	119	0.63	+	78	0.046	3.9E-4
1	0	0.168	119	0.63	-	76	0.054	4.6E-4
1	0	0.217	92.2	5.00	+	75	0.041	4.5E-4
1	0	0.217	92.2	5.00	-	72	0.044	4.8E-4
1	0	0.217	92.2	0.63	+	71	0.036	3.9E-4
1	0	0.217	92.2	0.63	-	69	0.043	4.6E-4
Average								4.4E-4

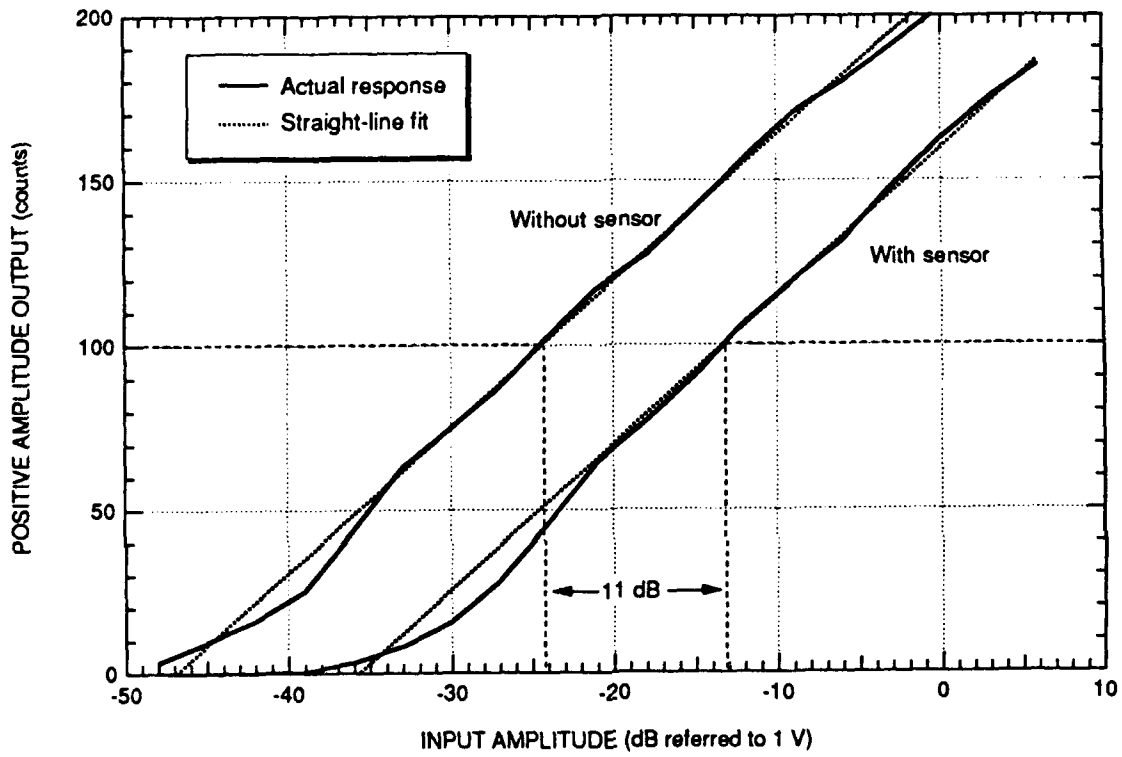

27265-110

Figure 10. Relative Gain of Current Sensor.

3 ENVIRONMENTAL TESTS

3.1 GOALS

The environmental tests were to demonstrate that the TPM can survive the stresses expected during launch and operations, without any unexpected degradation in performance. These stresses are due either to vibration or to changes in temperature and atmospheric pressure. (Changes in atmospheric pressure are not inherently stressful, except that absence of an atmosphere removes convection as a path for heat dissipation.)

Although it is preferable for an instrument to survive testing without any failures, it is desirable that any failure that would otherwise happen during flight would be revealed first during the tests. The stresses used during environmental tests were carefully chosen to encourage incipient failures without inducing others that otherwise never occur.

In an actual mission, strong vibration stresses occur only during launch and orbital insertion. Thus, one test under the anticipated conditions is usually sufficient. Thermal stresses, on the other hand, are typically cyclic throughout the mission. It is desirable to subject equipment to several thermal cycles before launch to reveal incipient thermal failures. Although the tests described in Section 3.4 included only one complete thermal cycle, the assembled instrument had already been subjected to five cycles between the temperature extremes during calibration, and some individual boards had undergone more (Section 2.4).

3.2 OVERALL PROCEDURE

We tested the TPM's electrical performance before, during, and after the test period to detect any unexpected changes due to the stresses of testing. The functional tests were performed using SRI-built TPM ground support equipment (GSE). We had also performed identical tests before the TPM was shipped to the Geophysics Directorate of Phillips Laboratory. **Table 3** lists the data sets taken throughout the environmental tests.

A single functional test consisted of exciting each of the six sensors with pulses of both polarities at six amplitudes covering a 50 dB range and recording the outputs of each of five parameters per channel. Thus each functional test yielded 360 data points covering most of the

Table 3
ENVIRONMENTAL TEST DATA SETS

Data Set	1990 Date	Time	Temp ¹ (°C)	Press (atm)	Chan 5 ² Adapter	Notes
1	26 Nov	1000	25	1	1	Bench test; direct stimulus
2	26 Nov	1723	25	1	2	In chamber; direct stimulus
3	27 Nov	0830	23	0	2	In chamber, overhead plate stimulus
4	27 Nov	2210	-6	0	2	Cold start; power on henceforth
5	28 Nov	0015	5	0	2	
6	28 Nov	0100	7	0	2	
7	28 Nov	0400	8	0	2	
8	28 Nov	0725	8	0	2	
9	28 Nov	1010	7	0	2	
10	28 Nov	1305	33-40	0	2	
11	28 Nov	1710	71-76	0	2	
12	28 Nov	2100	71-76	0	2	Drift test
13	28 Nov	2105	71-76	0	2	
14	29 Nov	0109	71-76	0	2	
15	29 Nov	0455	71-76	0	2	
16	29 Nov	0925	71-76	0	2	
17	29 Nov	1300	71-76	0	2	
18	29 Nov	1330	71-76	0	2	Drift test
19	29 Nov	1400	62-66	0	2	Drift test
20	29 Nov	1430	54-56	0	2	Drift test
21	30 Nov	0900	22-24	0	2	
22	30 Nov	1000	24-26	0	2	
23	30 Nov	1115	23-25	0	2	Direct stimulus
24	30 Nov	1245	23	0	2	Channel 5 only
25	3 Dec	1600	23-29	1	2	Bench test after vibration testing
26	4 Dec	0930	24	1	1	Channel 5 only
27	4 Dec	1010	24	1	1	In chamber to reduce noise

¹ Temperatures measured by the TPM's internal sensor. See Section 3.4.5.

² See Section 3.4.3 for a description of the two adapters used on Channel 5 (the current sensor).

dynamic range of each channel and parameter. In addition, we recorded the TPM's power consumption, the central processor's internal temperature and its main supply voltage. We also cycled the power to the TPM to verify that it would start up reliably.

Although the TPM GSE records the raw test data in computer files, it is cumbersome to extract the data in a form useful for later comparisons. We used the raw data files, only as backup to the written data summaries we took by hand from the computer screen.

The results of the functional test are normally affected by the type of sensor stimulus and the TPM temperature. Changes in response between any two tests at a particular temperature and with the same stimulus would indicate a problem.

3.3 EQUIPMENT AND CONFIGURATION

In all cases, the TPM was in its full system configuration, with all six sensors connected and power to the E-field sensors supplied by the TPM central processor. The GSE supplied 28 Vdc power to the TPM central processor, and digital communications were through the GSE interface emulator.

The signal source was the GSE pulse generator, a compact battery-powered device that produces unipolar pulses with 200 ps rise time and 2 μ s fall time at a fixed rate of 1 Hz. The polarity and amplitude of the pulses are controlled by front panel controls, with the peak amplitude adjustable from 20 mV to 20 V.

The optimum way to stimulate the electric-field sensors is through a capacitive connection to the pulse generator. Part of the GSE is a test fixture that makes a direct connection to a sensor's plate and capacitively couples it to signals on a normal BNC connector. Capacitive coupling exactly simulates the character of electric-field excitation, but allows a compact configuration that is resistant to external noise. It does not provide an absolute measurement of the sensors' sensitivity to electric fields, but will reveal any changes in sensor response.

During the thermal vacuum tests, we also used a second method of electric-field excitation, which is described in Section 3.4.3.

To stimulate the current sensor, we applied the signal across a 50 Ω resistor, one lead of which passed through the sensor.

3.4 THERMAL VACUUM TESTS

3.4.1 Facilities

Thermal vacuum tests were performed at PL using the chamber known as MUMBO (Figure 11). MUMBO is a cylinder roughly 4 ft in diameter and 6 ft long. It contains a horizontal thermally controlled platen, of roughly 3 × 4 ft, on which test objects can rest. Its inside walls are bare stainless steel and remain at approximately room temperature at all times.

3.4.2 Test Limits

The vacuum pressure specified in the test plan was 10^{-5} torr or less. The high temperature was specified as 60°C and the low temperature as -10°C.

3.4.3. TPM Configuration

The electric-field sensor excitation method described above (Section 2.4.2) can be used to excite only one sensor at a time. Simultaneous excitation of all the sensors using similar fixtures would unacceptably reduce the signal amplitude, since the signal power would have to be divided among them. Since we could not manipulate the sensors to test them singly while they were in vacuum, we used an alternative configuration that allowed simultaneous excitation at the cost of signal fidelity (Figure 12).

We arranged the five sensors side by side and placed a metal plate approximately 1 cm above them. We applied the pulse signal to the overhead plate and the signal ground to the thermal platen on which the sensors rested. This arrangement presented a poor impedance match to the signal generator and distorted the waveforms. We could have reduced the distortion by using a large plate, suspending it farther above the sensors, and carefully terminating it, but this would also have greatly reduced the electric-field magnitude and therefore the dynamic range of the tests.

In any case, the signal distortion has no bearing on the validity of the tests, since our goal was to test the repeatability of TPM responses, not their absolute values. To be sure no changes in TPM responses were masked by the change in test configuration when we moved the TPM to and from the vacuum chamber, we made functional tests using both configurations at the beginning and end of the vacuum tests. We used the standard direct-stimulus test first to ensure that the TPM was performing normally, then immediately measured the normal responses to the plate stimulus. Repeating this at the end of tests, with virtually identical results, assured us that the baseline measurements with the plate stimulus represented normal TPM behavior.

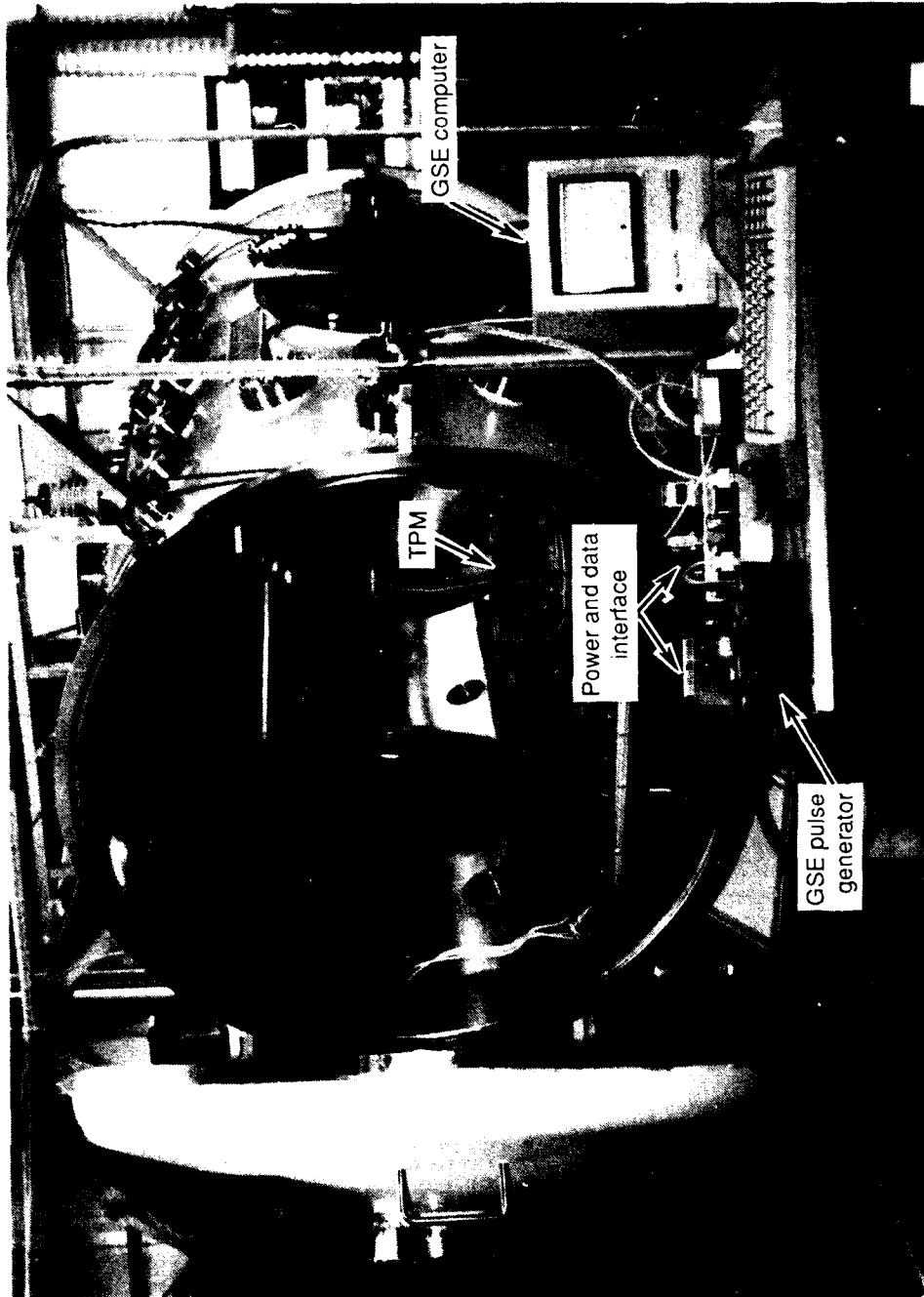

2726/r/r/11

Figure 11. TPM and GSE in Vacuum Chamber Laboratory.



27261/112

Figure 12. Electric-Field Stimulus Used in Vacuum Test.

When installing the TPM in the vacuum chamber, we also used a different adapter to drive the current sensor than we had used previously. At the time, we did not expect this to affect the data, but near the end of the tests, we realized that the derivative readings on the current sensor channel were consistently lower than they had been. When we returned the TPM to room temperature and pressure, we retested the channel using both adapters and found that the difference between them was responsible for the different results. Only the derivative readings were affected, because they are most sensitive to high frequencies. The second adapter had longer leads, and therefore higher inductance, reducing the high-frequency content of the signal. Like that of the plate stimulus for the field sensors, this distortion did not interfere with the test goals once we had recognized it.

3.4.4 Procedures

After placing the TPM in the chamber and making all the proper electrical connections, we ran a functional test using direct sensor stimulus. We briefly compared the results with those from previous tests and found no discrepancies. We then set up the overhead plate stimulus for the electric-field sensors, sealed the chamber, and pumped it down to minimum pressure. We executed the functional test again while the entire apparatus was still at room temperature.

We then set the thermal control system to a platen temperature of -10°C . During the initial cooldown, the TPM power was off so that it would reach a minimum temperature. After 12 hours at the low temperature, we applied power to the TPM and did a functional test. Power remained on throughout the rest of the thermal test period, except that we cycled the power once before each functional test to verify startup capability. We repeated the test every 3 hours for a total of 12 more hours.

After a total of 24 hours at the low temperature (12 with power off, 12 with power on) we raised the temperature control setting over a period of 1 hour to 60°C . With TPM power still on, we left it at that temperature for 24 more hours, making a functional test (including a power startup test) every 4 hours. At the end of the high-temperature test period, we also characterized a known error that is caused by component leakage at high temperatures (Section 3.4.6.5).

During the high-temperature functional tests, where repeatability was crucial, we always recorded the maximum value of each parameter, as this could be assumed to contain the least leakage error. We made separate measurements to determine the maximum leakage error for each parameter at each of three different temperatures, by recording the smallest and largest responses to a number of identical stimulus pulses. Since the leakage rate is independent of the initial reading, it was necessary to make these measurements at only one amplitude for each channel.

3.4.5 Thermal Considerations

We were not able to fasten the central processor and sensors to the thermal platen. Instead, we rested them on sheets of indium to increase thermal contact. We placed a thermocouple on each sensor and on three sides of the central processor. We recorded their readings throughout the tests, as well as the reading of the thermistor inside the processor. **Figure 13** shows the temperatures of the platen, the top of the processor, the processor interior, and a typical sensor, throughout the tests. Because of differences in thermal contact, individual sensors may have differed by a few degrees from that shown.

Because the walls of the vacuum chamber were at room temperature throughout the tests, they had a slight moderating effect on the temperatures of the test objects. For example, when the temperatures had stabilized after 12 hours with the platen at -10°C and TPM power off, the top of the processor and the sensors remained at about -5°C . The interior of the processor, which is thermally closer to the baseplate, was slightly cooler. At the high temperatures, the top of the processor again reached less of an extreme than its interior (62°C versus 75°C), although internal dissipation probably exaggerated this effect. The central processor's power dissipation raised its internal temperature about 18°C above the baseplate temperature at both extremes. The sensors reached a temperature about 2°C below the platen during the high-temperature tests. Their small power dissipation raised their exterior temperatures only about 1°C .

3.4.6 Results

Table 3 lists the 27 data sets taken during the entire test period. Of these, Sets 3 through 22 represent the thermal vacuum tests. The end-to-end results comparing Sets 1 and 27 are presented in Section 3.5.5. All test data are in digital counts, as produced by the TPM digital processor, and have a range from 0 to 255.

These data sets have four dimensions with a total of 360 loci (6 channels, 5 parameters, 6 amplitudes, and 2 polarities) and thus do not lend themselves to a simple graphical presentation. In the discussion that follows, the data are presented in tables. For those parameters that are sensitive to polarity, the tables show only their response to their intended polarity. For example, the responses of the positive amplitude parameters to negative pulses are not included. Any problem that would have been revealed in the residual opposite-polarity responses would certainly be at least as obvious in the correct-polarity data presented. Since the integral circuits do not discriminate polarity, but opposite polarities do exercise different portions of the circuits, the integral responses to both polarities are included separately.

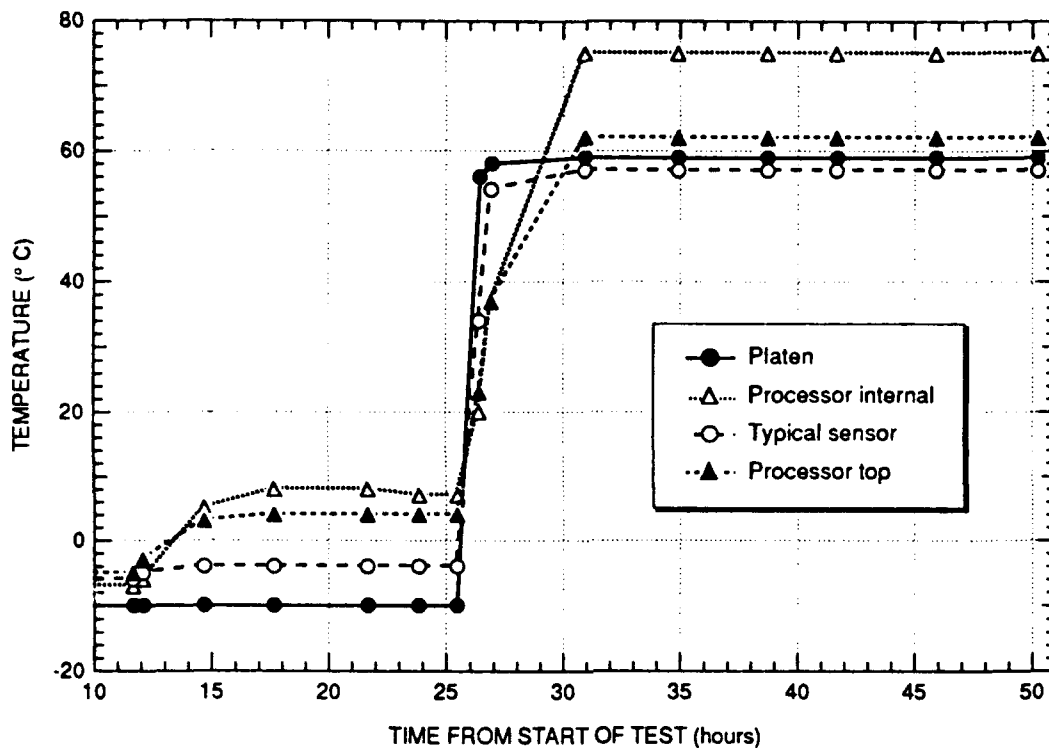

2726tr/113

Figure 13. Temperature During Vacuum Tests.

To evaluate these data, we must consider both the consistency of various sets at a given temperature and the relative responses at different temperatures.

3.4.6.1 Low Temperature

Tables 4 through 6 show the aggregate results of data Sets 5 through 9, which were made while the TPM baseplate temperature was -10°C and its internal temperature was between 5°C and 8°C . Table 4 shows the average values; Table 5 shows the standard deviations; and Table 6 shows the peak-to-peak deviations (the largest reading minus the smallest reading). Our previous experience with the TPM indicates that a peak-to-peak deviation of 5 or less and a standard deviation of 2 or less is normal. Almost all of the data are well within these limits, but they exceed the limits at three points, which are highlighted in the tables: the Channel 2 integral for a positive, -10 dB pulse; the Channel 4 integral for a negative, 0 dB pulse; and the Channel 4 integral for a negative, -40 dB pulse.

Table 7 shows the complete data recorded in Sets 5 through 9 for the three suspect points. In each case, the deviation is due not to a pattern of change, but to a single exceptional datum. Significantly, each of these is contained in Data Set 8. A number of other data sets contained similar exceptional points that the backup data files showed to be errors in data taking.

Table 4

AVERAGE OUTPUTS AT LOW TEMPERATURES

Channel	Input (dB)	Amplitude		Derivative		Integral	
		Positive	Negative	Positive	Negative	Positive	Negative
0	0	215	205	197	191	200	194
	-10	170	158	133	136	159	175
	-20	122	114	87	78	133	147
	-30	74	69	45	44	91	103
	-40	17	15	2	2	62	55
	-50	1	0	0	0	21	22
1	0	183	185	198	193	198	196
	-10	146	142	136	135	165	179
	-20	107	104	88	79	138	153
	-30	65	65	48	46	95	107
	-40	15	14	4	4	63	57
	-50	1	0	0	0	23	23
2	0	207	217	175	172	175	190
	-10	159	180	113	113	164	175
	-20	109	132	77	75	127	151
	-30	65	76	25	22	93	104
	-40	14	18	0	0	64	55
	-50	1	0	0	0	24	23
3	0	207	216	200	208	190	195
	-10	165	172	146	153	164	174
	-20	111	116	91	93	141	148
	-30	57	56	53	54	89	101
	-40	10	9	5	5	60	57
	-50	0	0	0	0	21	22
4	0	201	205	196	200	176	191
	-10	159	168	145	143	167	175
	-20	117	124	90	89	131	155
	-30	68	79	56	50	101	108
	-40	14	19	6	4	67	62
	-50	0	1	0	0	26	24
5	0	194	195	203	191	207	219
	-10	154	152	140	134	180	186
	-20	103	110	92	85	134	136
	-30	52	60	45	38	89	92
	-40	9	10	2	1	36	38
	-50	0	0	0	0	11	11

Table 5
STANDARD DEVIATIONS AT LOW TEMPERATURES

Channel	Input (dB)	Amplitude		Derivative		Integral	
		Positive	Negative	Positive	Negative	Positive	Negative
0	0	0.0	0.0	0.0	0.0	0.4	0.4
	-10	0.4	0.0	0.0	0.0	0.7	0.0
	-20	0.4	0.0	0.0	0.4	0.4	0.0
	-30	0.5	0.8	0.4	0.4	0.0	0.4
	-40	0.0	0.4	0.5	0.4	0.4	0.5
	-50	0.0	0.0	0.0	0.0	0.5	0.4
1	0	0.0	0.0	0.4	0.0	0.0	0.0
	-10	0.0	0.5	0.4	0.0	0.5	0.5
	-20	0.0	0.0	0.0	0.0	0.0	0.0
	-30	0.5	0.0	0.8	0.4	0.0	0.0
	-40	0.4	0.5	0.9	0.5	0.5	1.3
	-50	0.5	0.0	0.0	0.0	0.7	0.5
2	0	0.0	0.4	0.0	0.0	0.4	0.0
	-10	0.5	0.0	0.0	0.5	3.6	0.0
	-20	0.0	0.0	0.0	0.5	0.4	0.0
	-30	0.0	0.0	1.3	0.4	0.4	0.4
	-40	0.5	0.4	0.0	0.0	0.0	0.0
	-50	0.4	0.9	0.0	0.0	0.4	0.0
3	0	0.0	0.0	0.4	0.9	0.4	0.4
	-10	0.0	0.4	0.0	0.0	0.0	0.4
	-20	0.0	0.0	0.0	0.4	1.1	0.0
	-30	0.5	1.1	0.8	0.4	0.5	0.0
	-40	0.5	0.8	0.0	0.5	0.4	0.4
	-50	0.0	0.0	0.0	0.0	0.9	0.4
4	0	0.0	0.9	0.4	0.0	0.9	0.5
	-10	0.0	0.0	0.0	0.5	4.6	0.0
	-20	0.0	0.0	0.0	0.0	0.5	0.0
	-30	0.0	0.0	0.8	0.5	0.5	0.0
	-40	0.5	0.5	0.5	0.4	0.0	2.3
	-50	0.0	0.5	0.0	0.0	0.8	0.7
5	0	0.0	0.0	0.0	0.4	0.0	0.5
	-10	0.0	0.0	0.0	0.0	0.4	0.0
	-20	0.0	0.0	0.4	0.5	0.0	0.0
	-30	0.8	0.5	0.5	0.5	0.0	0.0
	-40	0.4	0.0	0.0	0.0	0.0	0.5
	-50	0.0	0.0	0.0	0.0	0.0	0.0

Table 6

PEAK-TO-PEAK DEVIATIONS AT LOW TEMPERATURES

Channel	Input (dB)	Amplitude		Derivative		Integral	
		Positive	Negative	Positive	Negative	Positive	Negative
0	0	0	0	0	0	1	1
	-10	1	0	0	0	2	0
	-20	1	0	0	1	1	0
	-30	1	2	1	1	0	1
	-40	0	1	1	1	1	1
	-50	0	0	0	0	1	1
1	0	0	0	1	0	0	0
	-10	0	1	1	0	1	1
	-20	0	0	0	0	0	0
	-30	1	0	2	1	0	0
	-40	1	1	2	1	1	3
	-50	1	0	0	0	2	1
2	0	0	1	0	0	1	0
	-10	1	0	0	1	8	0
	-20	0	0	0	1	1	0
	-30	0	0	3	1	1	1
	-40	1	1	0	0	0	0
	-50	1	2	0	0	1	0
3	0	0	0	1	2	1	1
	-10	0	1	0	0	0	1
	-20	0	0	0	1	2	0
	-30	1	3	2	1	1	0
	-40	1	2	0	1	1	1
	-50	0	0	0	0	2	1
4	0	0	2	1	0	2	1
	-10	0	0	0	1	11	0
	-20	0	0	0	0	1	0
	-30	0	0	2	1	1	0
	-40	1	1	1	1	0	6
	-50	0	1	0	0	2	2
5	0	0	0	0	1	0	1
	-10	0	0	0	0	1	0
	-20	0	0	1	1	0	0
	-30	2	1	1	1	0	0
	-40	1	0	0	0	0	1
	-50	0	0	0	0	0	0

Table 7

HISTORY OF SUSPECT PARAMETERS

Data Set	Channel 2 Positive Integral -10 dB	Channel 4 Positive Integral -10 dB	Channel 4 Negative Integral -40 dB
5	162	165	63
6	162	164	65
7	162	165	63
8	170	175	59
9	162	165	61

Unfortunately, the data taker for Data Set 8 did not record the corresponding backup file, and thus we cannot be sure whether these three data are also erroneous. However, if they did indicate a failure in TPM performance, we would certainly expect to see other indications in neighboring data. Since the data include no other indications of failure, we conclude that these exceptions are not significant.

3.4.6.2 High Temperature

Tables 8 through 10 show the aggregate results of data Sets 11 through 17 (excluding Set 12, which was a test of leakage rates; see Section 3.4.6.5), which were made while the TPM baseplate was at 60°C and its internal temperature was between 71°C and 76°C. Once again, most of the data indicate acceptable deviations. There is one exceptional point: the Channel 4 integral for a positive pulse of -20 dB. Table 11 and Figure 14 show the values of this point, and those of the same channel at neighboring amplitudes, in the various data sets.

There is a consistent, if slight, downward trend in the response to -20 dB pulses. All of the values except that for Data Set 16 are confirmed by backup data files (no file exists for Set 16). This trend is sufficient to suggest a possible weakness in the Channel 4 integral. However, it is contradicted by the fact that no similar trend exists for inputs of other amplitudes, or for the opposite polarity at the same amplitude. The fact that the Channel 4 integral has relatively high thermal leakage (as described in Section 3.4.6.5) may have contributed to this high observed variance.

Table 8

AVERAGE OUTPUTS AT HIGH TEMPERATURES

Channel	Input (dB)	Amplitude		Derivative		Integral	
		Positive	Negative	Positive	Negative	Positive	Negative
0	0	214	205	174	169	195	191
	-10	168	158	111	105	154	177
	-20	124	119	75	67	135	149
	-30	81	78	13	13	93	101
	-40	27	27	0	0	63	56
	-50	6	7	0	0	20	19
1	0	183	184	177	174	189	201
	-10	145	142	113	106	164	182
	-20	111	108	74	68	143	154
	-30	73	71	15	15	95	105
	-40	26	27	0	2	65	58
	-50	7	7	0	2	26	25
2	0	206	214	174	170	166	199
	-10	160	175	110	110	158	178
	-20	117	131	75	71	131	150
	-30	74	84	16	14	90	103
	-40	28	29	0	0	64	55
	-50	7	8	0	0	24	23
3	0	207	213	181	188	181	187
	-10	164	170	117	121	162	172
	-20	118	121	76	77	145	150
	-30	76	78	17	18	89	99
	-40	23	24	3	0	61	59
	-50	5	6	3	0	23	23
4	0	202	206	177	180	167	204
	-10	159	167	117	115	163	178
	-20	119	126	77	74	134	156
	-30	78	84	20	16	98	107
	-40	27	31	0	0	67	59
	-50	7	9	0	0	30	28
5	0	192	191	184	171	208	219
	-10	152	150	119	107	182	189
	-20	108	114	77	71	135	138
	-30	67	74	14	12	89	92
	-40	19	22	0	0	35	38
	-50	3	4	0	0	13	14

Table 9
STANDARD DEVIATIONS AT HIGH TEMPERATURES

Channel	Input (dB)	Amplitude		Derivative		Integral	
		Positive	Negative	Positive	Negative	Positive	Negative
0	0	1.6	0.8	0.8	0.8	0.0	0.8
	-10	1.0	0.4	0.4	1.0	0.5	0.4
	-20	0.8	0.5	1.0	0.5	1.0	0.0
	-30	1.3	0.4	1.1	0.8	0.4	0.5
	-40	1.5	0.6	0.0	0.0	1.0	1.1
	-50	1.2	0.6	0.0	0.0	0.5	2.1
1	0	1.0	1.0	1.6	1.0	1.4	0.5
	-10	0.5	0.4	0.8	1.2	1.5	0.0
	-20	0.4	0.5	0.9	0.5	0.8	0.5
	-30	0.4	0.4	0.8	0.8	0.5	0.6
	-40	0.4	0.6	0.0	0.4	0.4	0.5
	-50	0.0	0.6	0.0	0.5	1.5	1.4
2	0	1.0	1.1	1.0	0.8	1.6	0.9
	-10	1.0	0.0	0.8	1.0	0.8	0.8
	-20	0.0	0.4	0.8	1.2	2.8	0.9
	-30	0.4	0.5	1.2	0.8	1.0	1.1
	-40	0.4	0.6	0.0	0.0	1.2	1.0
	-50	0.5	0.4	0.0	0.0	1.0	1.0
3	0	0.0	1.2	0.8	0.8	0.8	1.0
	-10	0.4	0.4	0.6	1.3	1.0	0.4
	-20	0.4	0.8	0.9	0.8	0.8	0.5
	-30	0.5	0.5	1.0	0.8	0.5	0.4
	-40	0.5	0.8	0.0	0.0	0.5	0.6
	-50	0.4	0.5	0.5	0.0	1.3	1.5
4	0	0.8	1.2	1.8	1.0	1.2	0.8
	-10	0.8	0.4	0.8	1.3	0.4	0.6
	-20	0.5	0.4	0.8	1.3	1.6	0.8
	-30	0.8	0.4	1.4	1.2	0.8	0.4
	-40	0.6	0.5	0.0	0.0	0.5	0.8
	-50	0.6	0.5	0.0	0.0	1.4	1.0
5	0	1.8	0.8	1.2	1.0	1.3	0.8
	-10	0.8	0.5	0.4	0.8	0.8	0.4
	-20	0.5	0.4	0.6	0.6	0.5	0.5
	-30	0.4	0.5	0.5	0.5	0.0	0.4
	-40	0.9	0.5	0.0	0.0	0.5	0.5
	-50	0.5	0.0	0.0	0.0	0.4	0.5

Table 10

PEAK-TO-PEAK DEVIATIONS AT HIGH TEMPERATURES

Channel	Input (dB)	Amplitude		Derivative		Integral	
		Positive	Negative	Positive	Negative	Positive	Negative
0	0	4	2	2	2	0	2
	-10	3	1	1	2	1	1
	-20	2	1	2	1	3	0
	-30	4	1	2	2	1	1
	-40	4	2	0	0	3	2
	-50	3	2	0	0	1	5
1	0	2	3	3	2	4	1
	-10	1	1	2	3	4	0
	-20	1	1	2	1	2	1
	-30	1	1	2	2	1	2
	-40	1	2	0	1	1	1
	-50	0	2	0	1	4	4
2	0	2	3	2	2	4	2
	-10	2	0	2	2	2	2
	-20	0	1	2	3	8	2
	-30	1	1	3	2	3	3
	-40	1	2	0	0	3	2
	-50	1	1	0	0	3	2
3	0	0	3	2	2	2	3
	-10	1	1	2	3	2	1
	-20	1	2	2	2	2	1
	-30	1	1	3	2	1	1
	-40	1	2	0	0	1	2
	-50	1	1	1	0	3	4
4	0	2	3	4	3	3	2
	-10	2	1	2	3	1	2
	-20	1	1	2	3	5	2
	-30	2	1	4	3	2	1
	-40	2	1	0	0	1	2
	-50	2	1	0	0	3	3
5	0	5	2	3	2	3	2
	-10	2	1	1	2	2	1
	-20	1	1	2	2	1	1
	-30	1	1	1	1	0	1
	-40	2	1	0	0	1	1
	-50	1	0	0	0	1	1

Table 11

CHANNEL 2 INTEGRAL HISTORY

Data Set	Channel 2 Positive Integral -10 dB	Channel 2 Positive Integral -20 dB	Channel 2 Positive Integral -30 dB
11	157	134	89
13	159	133	88
14	158	131	90
15	157	131	89
16	158	129	91
17	158	127	90

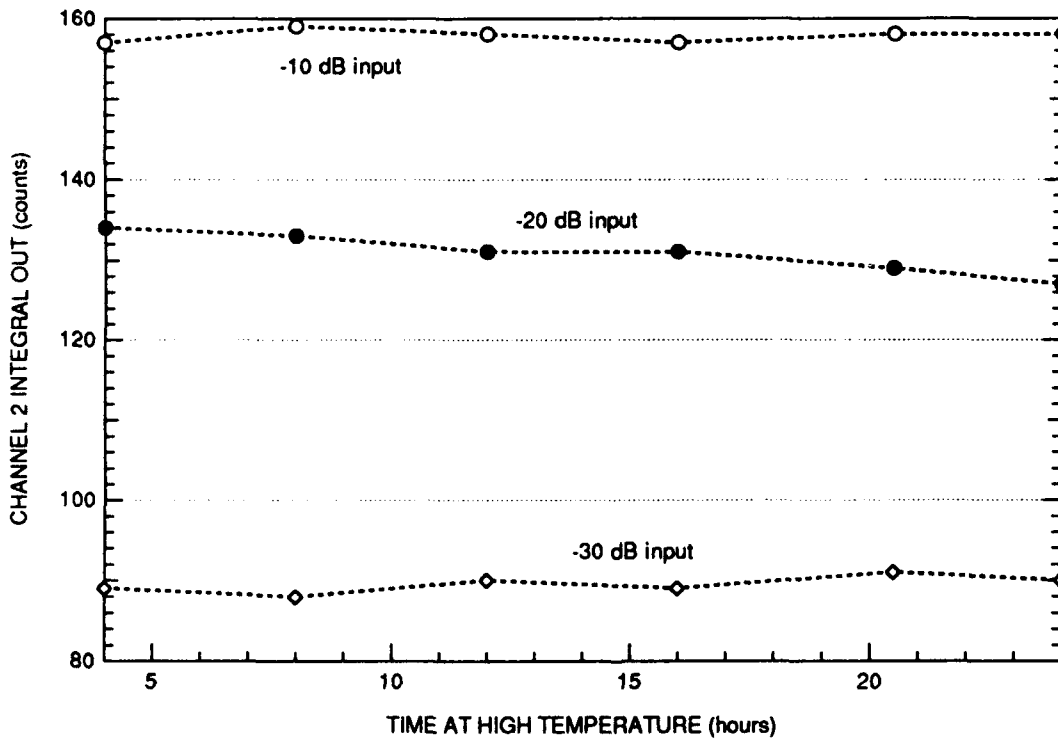

2762r/114

Figure 14. Channel 2 Integral History.

3.4.6.3 Low versus Room Temperature

The pulse analyzer circuits normally show small changes in response at low temperatures. The amplitude and integral parameter responses typically decrease, while the derivative circuit responses increase slightly. **Table 12** shows the average changes in output from each channel and parameter when the TPM temperature was lowered from room temperature. For each parameter, the first column is the average change measured during laboratory calibration, and the second is that measured during the thermal vacuum tests. The low-temperature calibration data were taken at a temperature of 10°C (the internal temperature of the TPM circuits for the low-temperature vacuum tests was from 5°C to 8°C).

Table 12 shows that, with two exceptions, the TPM performed within a few counts (from a range of 255) of the expected values. The outputs from the positive and negative derivative parameters on Channel 2, however, were significantly below expectations and the actual responses of the other channels. The deviation of -13 counts is equivalent to roughly a 3 dB underestimation of the field derivative. Data from Channel 2 at the other temperatures, and from the integral and amplitude parameters of Channel 2, show no similar anomalies. Because the derivative circuits are sensitive to the highest input frequencies, they are the most likely to be affected by such problems as poor cable connections and other mechanical changes in the test setup. Without further testing, it is impossible to say whether the change in observed response is due to the TPM itself or to external factors.

3.4.6.4 High versus Room Temperature

At high temperatures, the TPM's amplitude and integral parameters show almost no change in response, while the sensitivity of the derivative circuits decreases notably. **Table 13** shows this pattern in both the laboratory calibration data and the thermal vacuum test data. The amplitude channels show a small but consistent increase in response (2 to 4 counts) compared with the calibration data. Because this increase is consistent from channel to channel, it is likely an artifact of the different test conditions. The calibration data include averaged responses to a wide variety of pulse shapes, whereas the thermal vacuum tests involved only one waveform as stimulus. Any variation in TPM response that is peculiar to that waveform might bias the results of the vacuum tests, whereas its effect would be diluted in the calibration test results.

3.4.6.5 High-Temperature Leakage Errors

Each parameter of each channel retains its most recent peak value in an analog sample-and-hold circuit until data are requested by the PASP Plus interface (normally once every

Table 12

AVERAGE CHANGE FROM 25°C TO 8°C

Channel	Positive Amplitude		Negative Amplitude		Positive Derivative		Negative Derivative		Integral	
	Cal	Vac	Cal	Vac	Cal	Vac	Cal	Vac	Cal	Vac
0	-1	1	0	3	-12	-12	-12	-12	1	-1
1	-1	3	0	3	-15	-12	-14	-11	-2	1
2	0	4	0	1	-15	-13	-14	-12	-1	0
3	0	4	-1	4	-14	-13	-15	-14	2	-1
4	1	4	0	3	-13	-13	-14	-13	2	2
5	0	2	0	2	-13	-13	-13	-11	1	1

Cal = Average change measured during laboratory calibration

Vac = Average change measured during thermal vacuum tests

Table 13

AVERAGE CHANGE FROM 25°C TO 75°C

Channel	Positive Amplitude		Negative Amplitude		Positive Derivative		Negative Derivative		Integral	
	Cal	Vac	Cal	Vac	Cal	Vac	Cal	Vac	Cal	Vac
0	-1	-2	-1	-3	3	3	2	4	-2	0
1	-1	-2	-1	-2	3	4	3	4	-2	-1
2	-3	-2	-1	-2	3	-10	3	-9	0	1
3	-4	-3	-4	-3	3	3	3	4	-1	0
4	-2	-1	-2	-1	3	4	3	4	-1	2
5	-2	-2	-3	-2	3	2	4	3	-1	0

Cal = Average change measured during laboratory calibration

Vac = Average change measured during thermal vacuum tests

second). At that time, the outputs of all the sample-and-hold circuits are digitized by the TPM's microprocessor. Since pulses occur at times uncorrelated with the sampling interval, a particular pulse must be held in the sample-and-hold for a random fraction of one sampling interval.

Sample-and-hold circuits depend on a capacitor to store the voltage of interest and a low-current buffer to measure the voltage without depleting the charge on the capacitor. A well-known (and inevitable) limitation of such circuits is that several paths for leakage from the capacitor increase the rate of charge depletion dramatically as their temperature increases. In the TPM, this leakage can become noticeable at high operating temperatures, causing a negative error as the readings slowly decrease while they are held. This error did not affect our functional test data, because we were able to apply the same input repeatedly and note the maximum response (that with the smallest leakage error). During flight, we will know the bounds on the leakage error (from measurements recorded in this report), but the errors on individual pulses will be randomly distributed within those bounds.

We were able to measure the leakage accurately by applying pulses that repeat with a period nearly, but not exactly, equal to the sampling interval. Each successive pulse arrives at a slightly different time relative to the sampling time, and the amount of drift increases or decreases according to the difference between these times. At some time, a pulse arrives an instant before the sampling time and therefore has essentially no drift before it is sampled. That point can be recognized because the output will reach a maximum. If the pulse period is slightly longer than the sample period, the next pulse will arrive an instant after the next sample is taken and will thus wait almost an entire sample interval before being read out. The sampled voltage will thus be at its minimum. The difference between the maximum and minimum pulses is the drift during one sample interval.

Since the TPM includes one sample-and-hold circuit for each parameter output of each channel, each has a different leakage determined by the characteristics of its individual components. **Table 14** shows the magnitude of the leakage at three temperatures for each parameter. It also includes the average leakage for each channel and for each parameter. The leakage is constant regardless of the initial TPM output, so that it was necessary to measure it at only one input level (in this case, a full-scale input). Although the leakage rate in voltage or counts is constant, the logarithmic characteristic of the TPM outputs means that a constant error translates to a proportional error (constant percentage of output) when the values are converted to engineering units.

The leakage is highly dependent on temperature, approximately halving for each 10°C decrease. Such an exponential response to temperature is characteristic of diode junction leakage and confirms earlier laboratory experiments which indicated that diode reverse current is the dominant source of drift in the sample-and-hold circuits. For most parameters, the leakage error

Table 14

HIGH-TEMPERATURE LEAKAGE

Temperature	Channel	Amplitude		Derivative		Integral	Average
		Positive	Negative	Positive	Negative		
75°C	0	24	9	5	4	4	9
	1	3	7	7	0	4	4
	2	4	4	10	10	17	9
	3	1	9	1	5	3	4
	4	5	7	12	16	4	9
	5	10	3	4	7	8	6
	Avg:	8	7	7	7	7	7
65°C	0	12	4	3	2	2	5
	1	1	4	3	0	2	2
	2	2	2	5	5	10	5
	3	2	5	1	3	2	3
	4	4	3	6	7	4	5
	5	7	3	2	3	2	3
	Avg:	5	4	3	3	4	4
55°C	0	5	3	2	1	3	3
	1	0	2	1	0	2	1
	2	1	1	3	3	6	3
	3	2	3	0	1	0	1
	4	2	1	3	3	2	2
	5	4	1	3	1	1	2
	Avg:	2	2	2	2	2	2

is not significant at temperatures below 65°C, although it varies widely among the individual parameters. Some parameters show no significant leakage even at 75°C; a few are conspicuously higher than average at all temperatures. The parameters with the highest leakages are the Channel 0 positive amplitude (24 counts, or approximately 5 dB, at 75°C), the Channel 3 integral (17 counts at 75°C), and the Channel 4 negative derivative (16 counts at 75°C).

Since the electric-field sensor channels can be assigned arbitrarily to locations on the carrier, it would be wise to assign the channels with the lowest leakages to the most important locations. The overall leakage can also be controlled by, if possible, maintaining a moderate

operating temperature and/or reducing the sample interval. The latter measure would also have the advantage of improving time resolution in the TPM data and the disadvantage of increasing the data rate that the host experiment and telemetry system must handle.

3.5 RANDOM VIBRATION TESTS

3.5.1 Facilities

Vibration tests were performed with PL's large computer-controlled shake table (Figure 15). The system is capable of applying random vibrations with an arbitrary spectrum along one axis of a test object. PL personnel fabricated a test plate with suitable mounting holes for the TPM sensors, whereas the hole pattern in the TPM central processor baseplate was compatible with existing holes in the shake table fixture.

3.5.2 Test Limits

The vibration test limits were based on preliminary flight data from the Pegasus launch system engineers: 0.002 G²/Hz at 20 Hz, increasing to 0.01 G²/Hz at 50 Hz, constant to 1 kHz, then decreasing to 0.002 G²/Hz at 2 kHz, for a total of 3.8 G RMS.

3.5.3 TPM Configuration

Since the TPM must survive, but not operate during the vibration of launch, it was not electrically connected during vibration testing. The central processor and six sensors were simultaneously tested without any mechanical or electrical connections other than mechanical fastening to their baseplates.

3.5.4 Procedure

We ran a simulated test on the shake fixture before mounting the TPM to verify that the shake table was operating within the specified spectrum. The system was configured to abort the test if the amplitude at any frequency deviated more than 3 dB from its specified value. It operated within this limit throughout the tests.

The TPM central processors and electric-field sensors were fastened to the shake table in a manner consistent with the flight configuration. We attached the current sensor, which will be integrated within the PASP Plus flight controller, with double-sided adhesive tape.

In the first test, the shake table was configured to vibrate perpendicularly to the baseplate of the TPM. We designated this as the Y axis. Next the table was rotated so that vibration was

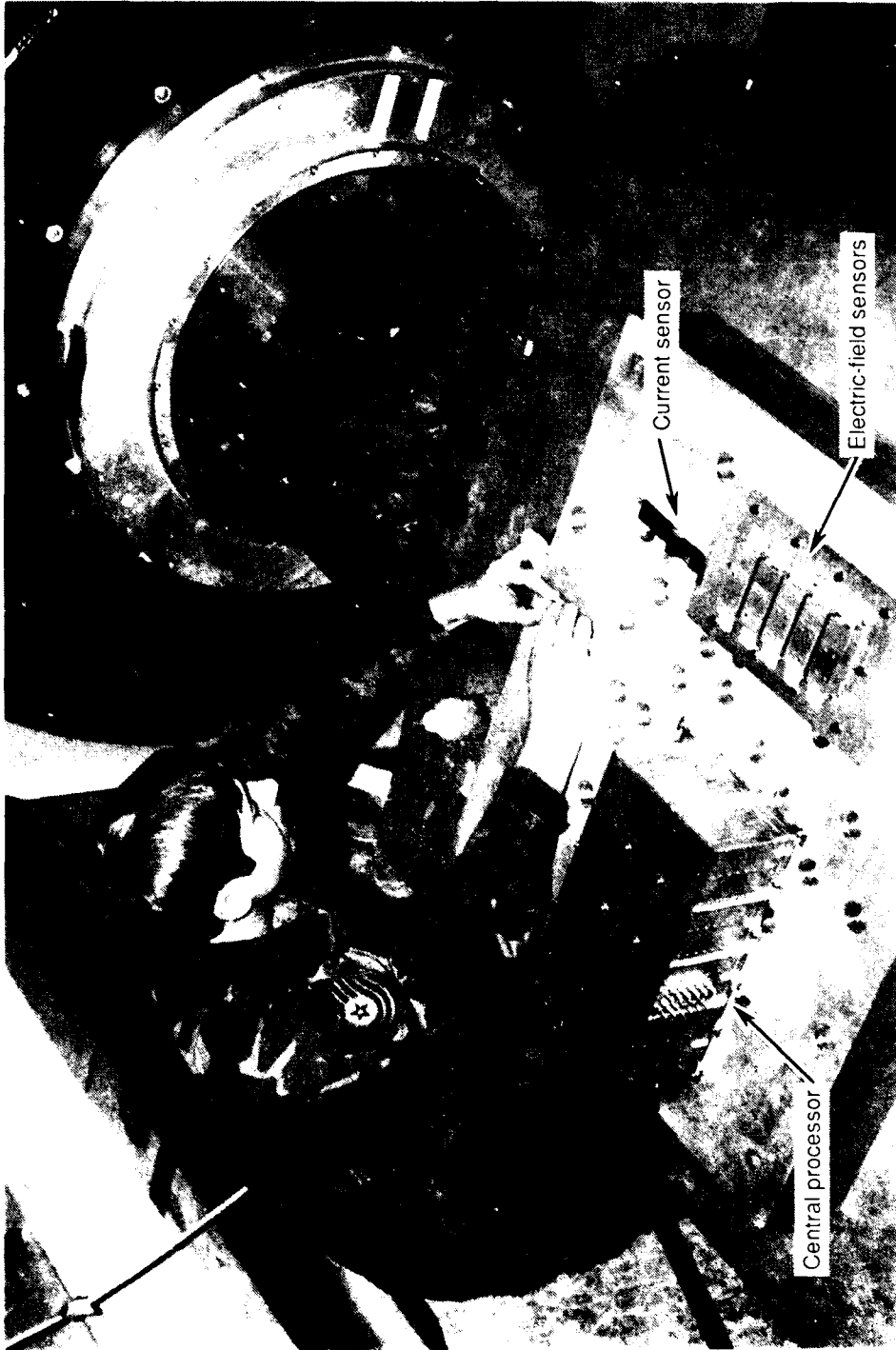

27261/15

Figure 15. TPM Installed on Shake Table.

parallel to the long sides of the central processor and sensors. We then rotated the TPM units so that the vibration was parallel to their short sides. In each orientation, the vibration was sustained for 1 minute. **Figure 16** shows the vibration spectrum from one axis, as measured by an accelerometer mounted on the shake table. Spectra from the other two axes were essentially identical.

3.5.5 Results

No visible or audible mechanical problems with the TPM or its sensors occurred during the tests. The only mechanical effect we observed was that two temporary screws used to hold a nonflight connector protector on the central processor shook out during the first test. We checked the flight screws after the last test and found none loose.

After the vibration tests, we performed two complete functional tests. **Table 15** shows the changes in response between the last data set (Set 27), and the first bench test we performed before the thermal vacuum tests (Data Set 1). Both data sets were taken at room temperature, although we did not record the exact temperature (which may have differed by about 5°C). We took Data Set 1 on a laboratory bench, and Set 27 with TPM inside the vacuum chamber (at atmospheric pressure). We took Set 27 in the vacuum chamber because it provided electromagnetic shielding and reduced the level of external noise in the integral channels.

The data in **Table 15** indicate that the tests did not cause any significant changes in TPM response, but several minor trends in the data require explanation. The outputs of the amplitude channels at the higher input amplitudes increased slightly, while they decreased slightly at lower amplitudes. These changes are not conspicuous because of their magnitudes, which are almost all two or fewer counts, but because they form a pattern that repeats in each channel. However, that fact indicates that the changes must be due to a change either in the applied signal or in the environmental conditions, because the channels use completely independent analog circuitry. Changes due to circuit degradation or failure would not be correlated between the channels. The only circuit faults that could affect all channels similarly (except in the case of an extraordinary coincidence) would occur in the analog-to-digital conversion circuitry, through which all the data pass. However, such faults would affect all parameters of all channels, and since the other parameters did not show the same trends, we can eliminate this as a possibility also. The changes in this case are small enough to likely be due to the different conditions of the two tests (different cables, slightly different temperatures, and different electromagnetic noise).

Two other small but systematic changes are evident in **Table 15**: an overall increase in derivative readings and overall decrease in integral readings. Again, these changes are likely due to changing test conditions, since they are common to all channels. In the case of the integral

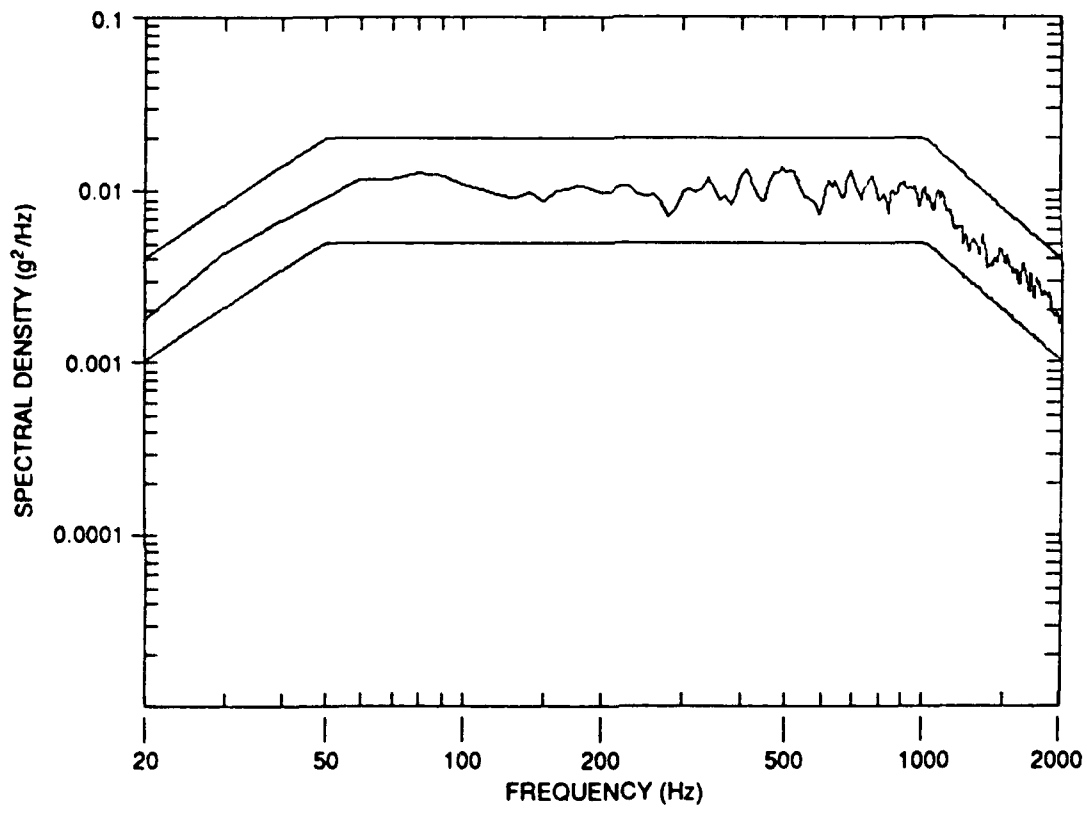

2726fr/16

Figure 16. Random Vibration Spectrum.

Table 15

CUMULATIVE CHANGES IN RESPONSE

Channel	Input (dB)	Amplitude		Derivative		Integral	
		Positive	Negative	Positive	Negative	Positive	Negative
0	0	1	0	0	0	-1	0
	-10	2	1	2	2	0	-2
	-20	1	1	1	3	-1	-2
	-30	0	0	1	1	1	-1
	-40	-1	-1	3	3	0	-2
	-50	-1	-1	1	0	-1	-1
1	0	1	0	1	2	-1	-2
	-10	1	0	2	1	-2	-1
	-20	1	1	2	3	0	-1
	-30	0	0	1	1	-1	-1
	-40	-1	0	2	2	2	-3
	-50	-1	-3	1	1	-2	-1
2	0	0	1	0	0	-2	-1
	-10	1	0	1	2	0	-2
	-20	1	1	4	3	-1	-1
	-30	-1	2	1	1	0	-2
	-40	-2	-1	3	3	-1	-2
	-50	-2	-1	1	1	-7	-7
3	0	2	1	0	0	-1	-2
	-10	1	1	1	2	-1	-3
	-20	1	1	2	2	0	-1
	-30	-1	-1	1	1	0	-2
	-40	-4	-5	3	3	0	-3
	-50	-2	-3	0	2	0	-2
4	0	1	0	0	1	-2	-1
	-10	1	1	2	2	-1	-1
	-20	2	1	3	2	0	-1
	-30	0	1	1	1	-1	-2
	-40	-2	-1	2	3	0	-3
	-50	-1	-2	1	0	-4	-5
5	0	0	1	-1	0	-1	-1
	-10	0	1	0	0	-1	-2
	-20	-2	-1	-1	0	-1	-1
	-30	-2	-2	0	1	-1	-1
	-40	-2	-2	0	0	0	0
	-50	-1	-2	0	0	0	-2

parameters, which are the most sensitive to external noise, their decrease in output is probably due to the lower noise in the vacuum chamber environment where Data Set 27 was measured. This becomes more evident at the lower amplitudes. Significantly, the greatest changes in integral readings occurred at the lowest amplitudes (Channels 2 and 4 at -50 dB), where noise sometimes caused ambiguous readings.

3.6 SUMMARY

Room-temperature functional tests made before and after the beginning of environmental testing revealed no significant changes in TPM response (Section 3.5.5). Data taken at other temperatures included a few that may warrant further investigation. During low-temperature tests, we recorded three exceptional data from three different parameters, but it seems likely they are the result of errors in manual data recording (Section 3.4.6.1). Comparison of the low-temperature and room-temperature data showed a significant deviation from expected behavior in the derivative outputs from Channel 2 (Section 3.4.6.3). This deviation may be due to an experimental artifact or to a failure in the TPM circuitry (most likely the E-field sensor). Further testing would be required to find the cause of the deviation and understand its ramifications. Finally, data from the high-temperature tests revealed a suspicious trend in the integral parameter of Channel 2. Although the data do not conclusively indicate a failure, they warrant close scrutiny of that parameter's performance during future operation of the instrument (Section 3.4.6.2).

4 INTEGRATION CONSIDERATIONS

4.1 ELECTROMAGNETIC COMPATIBILITY

Since the TPM measures broadband electromagnetic interference, it cannot discriminate against transients from sources other than discharges. The TPM sensors respond to peak fields as low as 5 V/m. To preserve the TPM's full dynamic range for discharge measurements, the instantaneous peak amplitude of fields radiated from other equipment with frequency components in the range of 20 kHz to 200 MHz must be kept below 5 V/m at the sensor locations. Outside these frequency limits, the TPM sensitivity decreases at 20 dB per decade.

4.2 ELECTRIC-FIELD SENSOR PLACEMENT

The TPM can only measure electric fields at the locations of its sensors, not at the location of a discharge. SRI's experiments show that the electric field from a discharge varies inversely as its distance from the discharge raised to some exponent.* The value of the exponent depends on the nature of the discharge and on local propagation conditions. The exponent is about 3 for typical spacecraft materials on flat conducting surfaces. For example, a discharge that produces the TPM's full-scale response at a distance of 20 cm would be barely detectable (one thousand times smaller amplitude) at 2 m. A small, nearby discharge and a large, distant one may result in identical data from the TPM.

This ambiguity between magnitude and distance can be overcome by placing several sensors so that they cover overlapping areas. Their responses to individual discharges can then be used to calculate both absolute magnitude and location. Multiple nearby sensors would also improve the range of pulse magnitudes that can be measured at locations between the sensors. Even on a relatively small satellite like Pegastar, all five TPM electric-field sensors will certainly provide useful information if they are properly distributed around the locations of interest.

The separation between the central processor and the sensors is limited by the performance of RF cables that carry the sensor signals. Longer cables have greater signal loss and are more susceptible to interference. Interference should not be a problem if a well-shielded (preferably doubled braid) coaxial cable is used, so signal loss is the main consideration. Loss in each cable should be limited to 1 to 2 dB at 200 MHz (assuming the loss increases with frequency). For example, RG-142 cable has 0.06 dB of attenuation per foot at 200 MHz. Thus, the attenuation of RG-142 would be below 1 dB for lengths up to 16 feet.

* J. E. Nanevicz, et al., "Electromagnetic Fields Produced by Simulated Spacecraft Discharges," Paper P80-0005, Applied Electromagnetics and Optics Laboratory, SRI International, Menlo Park, CA.

4.3 CHANNEL PRIORITIES

Because each channel is in some respects unique, it may be desirable to assign those channels with the best performance to the highest-priority locations. Because we have individually calibrated the normal response variations between the channels, these provide no basis for assigning priorities. The only uncertainty factor that differs significantly from channel to channel is high-temperature leakage (Section 3.4.6.5), so this is a primary consideration for assigning priorities. The two anomalies observed during thermal-vacuum testing are also significant in assessing overall channel performance.

Each of the five parameter outputs of each channel (positive and negative amplitude, positive and negative derivative, and integrated magnitude) has a unique leakage value, so we must weigh the importance of each parameter to the overall board function. In general, amplitude will be of greatest interest, so we have calculated a figure of merit that is the sum of the largest amplitude leakage (of the positive or negative amplitude parameter) and the average leakage of the remaining parameters (Table 16). Although Channel 5 is included in Table 16, it has already been assigned to the current sensor, whose location was designated long ago. The locations of the electric-field sensors for Channels 0 through 4 are still flexible.

Channel 2, which would be assigned third priority based on high-temperature leakage, showed an unexpected drop in derivative response at low temperatures (Section 3.4.6.3). Although further testing would be required to properly diagnose the cause of this anomaly, it indicates the possibility of a problem with the sensor circuitry. The integral parameter of Channel 2 also showed a trend during high-temperature testing that, while inconclusive, could be the precursor of a failure. For lack of further data, these indications warrant dropping Channel 2 to the lowest priority.

Table 17 shows a recommended order of priority that accounts for these factors. This order should be reconsidered if any additional data are gathered on the response anomalies.

4.4 RADIATION SUSCEPTIBILITY

Because the TPM's original mission was expected to last only a few days, radiation tolerance was not a consideration in TPM design or component selection. Now the TPM is planned to operate for many months on a Pegastar satellite whose orbit passes through the lower portion of the earth's inner radiation belt. The levels of radiation expected during this extended mission are high enough to damage some components in the TPM.

To improve the TPM's radiation tolerance requires either replacing the susceptible components or providing additional shielding. Replacing the components would require extensive rework and possible redesigning, because not all components are available in hardened

versions. We therefore do not consider replacing the components a viable option. Instead PL plans to surround the central processor with additional aluminum shielding. The additional shielding, in combination with that provided by the TPM's original enclosure and the surrounding spacecraft structures, is expected to ensure satisfactory operation of the TPM during at least the first six months of the mission. The TPM's data are most needed during this first phase of the one-to-three-year mission.

4.5 ELECTRIC-FIELD SENSOR GROUNDING

To meet a requirement of the original IMPS mission, the TPM has no direct current connection from its circuitry to its chassis. However, the electric-field sensors cannot properly measure the fields impinging on the satellite without some electrical connection to the spacecraft. Presently, this connection is through 0.4 μF of capacitance within each sensor, and a total of 2.4 μF within the central processor. Although the capacitive connection, which acts as a short circuit at radio frequencies, is adequate, a direct connection within each sensor provides the most accurate and noise-free measurements. The flight unit at the time of delivery included one sensor (number 1) with such a direct connection. We recommend that, pending approval of the PASP designers, ground connections be added to the remaining four E-field sensors. If for some reason this is inadvisable, sensor number 1 should be ungrounded. Grounding or ungrounding the sensors is a simple process that can be done any time before their final installation on the payload.

4.6 PREFLIGHT TESTING

At each stage of integration, the TPM should undergo at least one functional test of the type used during the environmental tests (Section 3). Its room-temperature responses should be compared with those in Table 18. Any significant deviations from these responses, if the measurement conditions are similar, may signal a problem with the TPM circuitry. Note that these data were made with the E-field sensors ungrounded. If subsequent data are taken with the sensors grounded, noise in the integral channels will be reduced, and the integral readings at low input amplitudes will be lower. Tests at high and low temperatures, like those described in Section 3, are also highly desirable.

The most thorough test of the TPM would be a complete recalibration, according to the procedures described in Section 2.4, shortly before final integration. This would not only reveal any failures, but also provide the most accurate data. Because well over two years will have passed between the launch and the calibration described in this report, some components in the TPM may have drifted.

Table 16

CHANNELS RATED BY LEAKAGE

Channel	Largest of Positive or Negative Amplitude	Average of Others	Total
1	7	4	11
3	9	3	12
2	4	12	16
4	7	11	18
0	24	4	28

Table 17

RECOMMENDED CHANNEL PRIORITIES

Priority	Channel	Note
1	1	
2	3	
3	4	
4	0	Highest amplitude leakage
5	2	Possible weak sensor

Table 18

ROOM-TEMPERATURE FUNCTIONAL TEST RESULTS

Channel	Input (dB)	Amplitude		Derivative		Integral	
		Positive	Negative	Positive	Negative	Positive	Negative
0	0	254	239	246	225	229	239
	-10	208	199	200	188	210	212
	-20	164	154	134	129	178	183
	-30	116	110	90	78	127	132
	-40	73	70	42	38	87	88
	-50	19	18	2	1	38	38
1	0	218	216	243	224	230	240
	-10	179	177	197	190	208	217
	-20	140	135	133	125	179	186
	-30	100	99	89	78	128	133
	-40	63	63	41	38	86	90
	-50	16	17	3	2	38	39
2	0	237	249	231	220	227	239
	-10	198	210	194	187	207	215
	-20	153	174	133	130	178	185
	-30	104	122	89	85	126	132
	-40	65	73	43	38	86	88
	-50	17	19	3	1	35	38
3	0	240	250	239	239	223	231
	-10	200	210	201	205	203	209
	-20	158	165	142	142	174	180
	-30	107	111	92	91	125	128
	-40	60	62	47	44	85	87
	-50	13	13	3	3	37	37
4	0	234	239	232	230	227	239
	-10	191	198	192	192	207	215
	-20	148	158	135	130	178	184
	-30	107	117	89	86	130	133
	-40	64	74	45	37	87	91
	-50	15	19	3	1	40	41
5	0	194	196	210	195	207	218
	-10	154	153	146	137	181	187
	-20	106	114	97	88	134	136
	-30	62	72	49	41	89	92
	-40	14	17	3	2	35	37
	-50	1	1	0	0	12	12

5 CONCLUSIONS

During the period covered by this report, we completed the construction and testing of the TPM, and delivered it to PL. We made extensive calibration measurements of the TPM, characterizing its responses to the full range of applicable inputs over its operating temperature range. As a result, we understand well its operating characteristics. In this report, we supply the condensed calibration data necessary to reduce data the TPM will generate in orbit.

We subjected the TPM to vibration and thermal vacuum tests that simulate those it will encounter during launch and orbit. Thorough functional tests before, during, and after these tests environmental indicate the TPM withstood these stresses well. We observed a few minor discrepancies, detailed in Section 3.

The TPM is now ready for integration into the spacecraft and eventual launch. However, two years will have passed between final assembly and launch. Although the testing described in this report has been very thorough, we recommend periodic functional testing, to verify the TPM's continued health, and recalibration before final integration.

Appendix

CALIBRATION RESULTS

The accompanying tables show the complete response of the TPM as measured during calibrations in June of 1990. Shown is the response of each parameter (positive amplitude, negative amplitude, positive derivative, negative derivative, and integral) of each of the six channels, at each of seven temperatures. These data may be used to translate TPM outputs into equivalent parameter inputs. The temperatures are internal temperatures reported by the TPM's internal thermistor.

Each datum represents the TPM output in digital counts (within a range of 0 to 255), in response to the corresponding input. The inputs are expressed in decibels, or twenty times the logarithm of the quantity of interest. For example, 0 dB represents 1 V in amplitude, 1 V/s in derivative, or 1 Vs in integral. Because of the inherently logarithmic response of the TPM, interpolations between the input values shown will be most accurate if done in the logarithmic domain.

The data shown are based on direct excitation of the TPM inputs, so they do not account for sensor calibration factors. A procedure for determining the input corresponding to a TPM output might be as follows:

1. Find the column appropriate to the channel, parameter, and temperature.
2. Find the nearest larger and smaller output in that column.
3. Interpolate between the corresponding dB values.
4. Raise ten to the power of the resulting dB value divided by twenty.
5. Divide by the equivalent height of the corresponding electric field sensor (Table 2) or by the transfer impedance of the current sensor (Section 2.4.3.2).

In practice this procedure would be implemented as a computer program. The exact algorithm used depends on the format in which data arrive and the rate at which they are to be processed.

Channel 0 Positive Amplitude Output							
Input (dB)	Temperature (C)						
	-10	0	10	25	40	56	72
6	243	242	242	241	238	236	235
3	230	229	229	228	226	224	223
0	216	216	215	214	211	210	209
-3	202	202	201	200	198	197	196
-6	191	190	190	189	186	185	185
-9	179	179	178	178	175	174	173
-12	163	163	162	162	159	158	157
-15	149	148	147	146	144	143	143
-18	134	133	133	133	131	131	130
-21	122	122	123	124	122	121	121
-24	106	108	109	110	109	109	109
-27	90	92	93	95	95	95	95
-30	77	80	81	83	82	83	83
-33	56	65	69	72	72	72	73
-36	38	44	50	57	57	59	60
-39	20	26	31	36	36	39	40
-42	11	17	20	24	23	26	27
-45	6	9	13	16	17	18	19
-48	1	4	6	8	9	10	9

Channel 0 Positive Derivative Output							
Input (dB)	Temperature (C)						
	-10	0	10	25	40	56	72
172	224	222	222	220	215	212	208
169	214	213	212	209	204	199	194
166	206	205	204	201	196	190	186
163	194	192	190	186	180	174	167
160	179	177	176	173	167	161	155
157	161	159	156	153	148	142	136
154	142	141	140	137	133	128	123
151	123	122	122	120	116	111	105
148	107	106	106	104	101	97	92
145	93	92	92	90	88	85	81
142	83	83	82	81	79	76	71
139	75	75	75	72	69	63	54
136	65	64	62	57	53	45	35
133	49	48	46	39	34	27	19
130	31	30	28	23	20	15	10
127	18	16	15	12	10	6	3
124	10	9	8	5	4	2	1
121	4	3	4	2	1	1	0
118	2	3	1	1	0	0	0

Channel 0 Negative Amplitude Output							
Input (dB)	Temperature (C)						
	-10	0	10	25	40	56	72
6	230	229	229	227	225	223	223
3	219	219	219	217	215	213	212
0	205	205	204	203	201	199	200
-3	192	191	191	189	187	186	186
-6	180	179	180	178	176	174	174
-9	170	169	169	167	166	163	164
-12	154	154	153	152	150	149	149
-15	138	137	137	137	135	135	135
-18	124	124	125	125	124	124	123
-21	114	115	115	116	115	115	115
-24	99	101	103	105	104	104	104
-27	84	86	88	91	90	91	92
-30	72	75	77	79	78	79	79
-33	49	59	65	69	69	69	70
-36	30	39	48	55	56	57	60
-39	14	23	28	33	36	38	39
-42	7	13	18	23	25	26	27
-45	2	7	11	14	16	17	18
-48	0	2	7	5	8	8	9

Channel 0 Negative Derivative Output							
Input (dB)	Temperature (C)						
	-10	0	10	25	40	56	72
172	212	210	209	207	203	198	192
169	205	203	203	200	194	190	184
166	196	195	194	191	186	181	175
163	186	185	183	180	174	169	163
160	174	173	172	169	164	159	152
157	159	158	157	154	148	142	135
154	144	143	141	137	132	126	119
151	125	123	121	118	113	107	101
148	103	101	101	99	96	92	86
145	86	86	85	84	81	78	74
142	75	74	73	73	71	68	65
139	67	66	66	65	63	60	53
136	59	59	58	56	52	46	37
133	48	47	45	41	35	28	21
130	35	34	31	26	22	17	11
127	20	19	17	13	11	7	4
124	11	10	8	6	5	2	1
121	4	4	3	2	2	1	0
118	2	3	2	1	0	0	0

Channel 0 Integral Output							
Input (dB)	Temperature (C)						
	-10	0	10	25	40	56	72
-98	248	248	248	250	248	251	252
-101	244	244	245	246	245	249	250
-104	246	246	246	247	247	249	251
-107	244	243	244	246	245	247	249
-110	242	242	242	244	243	246	248
-113	238	238	239	240	238	241	244
-116	233	233	234	235	234	236	238
-119	226	225	226	227	226	229	231
-122	221	221	222	222	221	223	225
-125	211	211	212	213	212	213	215
-128	199	199	199	200	200	200	202
-131	184	184	184	186	185	186	187
-134	168	168	169	171	170	170	171
-137	153	153	154	156	155	154	156
-140	138	138	139	141	140	139	141
-143	123	124	125	126	126	126	127
-146	111	111	112	113	113	113	114
-149	101	101	102	104	102	103	104
-152	89	89	90	92	91	91	92
-155	79	80	80	82	82	80	81
-158	65	66	67	68	67	65	67
-161	50	51	54	56	54	53	55
-164	37	38	39	43	39	37	41
-167	27	28	27	32	30	30	31
-170	25	26	25	27	27	26	27
-173	25	25	26	25	27	26	28
-176	24	25	26	25	27	26	28
-179	23	25	26	27	26	25	26
-182	26	25	25	27	26	26	26
-185	25	25	26	27	26	28	26

Channel 1 Positive Amplitude Output							
Input (dB)	Temperature (C)						
	-10	0	10	25	40	56	72
6	209	208	207	207	204	202	201
3	197	196	196	195	193	191	191
0	185	184	184	183	181	179	178
-3	173	172	172	171	169	167	167
-6	164	163	162	161	159	157	157
-9	154	153	152	151	149	148	147
-12	139	139	138	138	137	136	135
-15	125	125	125	125	125	124	123
-18	115	115	115	115	115	114	113
-21	105	106	107	107	107	106	105
-24	90	92	93	94	95	94	94
-27	76	78	80	81	82	82	82
-30	66	68	70	71	72	71	71
-33	45	54	59	62	63	63	63
-36	29	36	42	47	50	52	52
-39	14	20	25	29	32	34	34
-42	7	12	16	19	22	24	23
-45	3	6	9	13	15	16	16
-48	0	1	4	5	7	9	8

Channel 1 Positive Derivative Output							
Input (dB)	Temperature (C)						
	-10	0	10	25	40	56	72
172	223	221	220	217	211	207	201
169	214	212	211	208	202	196	189
166	206	205	203	200	194	189	182
163	194	193	191	187	181	175	167
160	181	180	178	175	169	163	153
157	164	163	161	157	150	144	134
154	146	144	143	139	134	128	119
151	125	124	123	120	115	110	102
148	107	107	107	104	101	97	90
145	93	93	93	91	88	84	79
142	83	83	82	81	78	75	67
139	76	75	75	72	69	63	49
136	65	65	64	58	53	45	31
133	50	49	47	40	35	27	17
130	33	32	30	24	20	15	8
127	18	17	16	12	10	7	3
124	10	9	9	6	4	2	1
121	4	4	3	2	1	1	0
118	1	1	5	1	0	0	0

Channel 1 Negative Amplitude Output							
Input (dB)	Temperature (C)						
	-10	0	10	25	40	56	72
6	207	207	206	206	204	202	201
3	198	198	197	197	195	193	192
0	185	185	184	184	183	179	180
-3	172	172	172	171	170	167	167
-6	162	162	161	160	159	156	156
-9	152	151	151	150	149	145	146
-12	137	136	136	135	134	132	132
-15	122	122	122	122	122	120	120
-18	110	111	111	112	111	110	110
-21	102	103	103	104	104	103	103
-24	90	92	93	94	95	94	94
-27	76	78	80	82	83	83	83
-30	65	68	70	71	73	72	72
-33	43	54	59	62	64	63	64
-36	26	35	45	50	54	54	55
-39	11	19	25	31	35	35	37
-42	5	11	16	20	24	24	26
-45	1	6	10	13	17	16	18
-48	0	1	4	5	9	7	9

Channel 1 Negative Derivative Output							
Input (dB)	Temperature (C)						
	-10	0	10	25	40	56	72
172	213	211	210	209	204	200	195
169	205	204	204	202	196	191	186
166	197	196	195	194	187	183	176
163	187	186	185	182	176	171	163
160	175	174	173	170	164	159	149
157	160	159	157	154	147	140	130
154	143	142	140	136	130	124	114
151	122	120	119	115	110	105	96
148	101	100	99	97	94	90	83
145	86	85	84	83	80	77	72
142	74	74	74	73	71	68	63
139	67	66	66	65	63	59	49
136	59	59	58	55	52	45	33
133	48	47	46	40	35	28	18
130	35	34	31	26	22	16	9
127	20	19	18	14	11	8	3
124	11	11	9	6	5	3	1
121	5	5	4	3	2	1	0
118	2	2	4	1	0	0	0

Channel 1 Integral Output							
Input (dB)	Temperature (C)						
	-10	0	10	25	40	56	72
-98	248	249	249	250	249	250	251
-101	245	245	245	247	245	247	250
-104	246	247	247	248	247	248	250
-107	245	245	246	246	246	247	249
-110	243	244	244	245	244	245	247
-113	240	240	240	241	240	241	243
-116	235	235	235	237	235	236	238
-119	227	227	227	228	228	228	230
-122	223	222	222	223	222	222	224
-125	214	213	213	215	213	214	216
-128	202	201	202	203	201	202	202
-131	188	187	187	189	187	188	189
-134	172	172	172	173	171	172	172
-137	156	156	156	157	156	157	156
-140	139	140	140	141	139	140	140
-143	125	125	126	127	124	126	126
-146	111	111	112	114	111	113	112
-149	101	101	102	103	101	102	102
-152	89	89	91	92	87	91	89
-155	79	79	80	83	77	81	79
-158	65	65	66	68	63	67	64
-161	51	50	52	56	50	53	52
-164	37	36	37	40	36	38	40
-167	25	23	28	31	26	28	29
-170	22	23	22	28	17	24	21
-173	21	21	21	27	16	25	20
-176	22	21	23	27	15	23	20
-179	21	20	22	28	15	23	21
-182	23	20	23	28	14	23	20
-185	23	19	23	27	15	24	21

Channel 2 Positive Amplitude Output							
Input (dB)	Temperature (C)						
	-10	0	10	25	40	56	72
6	224	224	223	223	220	219	219
3	214	214	214	214	211	210	210
0	202	202	201	201	199	197	197
-3	190	189	189	189	186	185	184
-6	179	179	178	178	176	174	174
-9	168	168	167	167	165	164	163
-12	152	151	151	151	148	148	147
-15	136	135	135	135	133	133	132
-18	121	121	122	123	121	121	121
-21	108	110	111	113	112	112	112
-24	91	94	97	99	100	100	100
-27	75	79	82	85	85	86	87
-30	64	68	71	74	74	75	75
-33	35	51	59	65	65	66	66
-36	20	32	41	51	54	57	57
-39	7	17	23	32	34	38	38
-42	3	9	15	22	24	26	27
-45	0	4	9	14	16	18	18
-48	0	1	3	6	7	10	10

Channel 2 Positive Derivative Output							
Input (dB)	Temperature (C)						
	-10	0	10	25	40	56	72
172	213	213	213	210	206	202	196
169	206	205	205	203	198	193	186
166	199	199	198	195	191	186	179
163	189	189	188	184	179	174	165
160	177	176	175	172	168	162	152
157	161	161	159	155	150	143	132
154	146	145	143	138	133	128	118
151	126	124	123	119	115	110	101
148	107	106	106	103	100	96	89
145	93	93	92	90	88	84	79
142	83	82	82	80	78	75	68
139	75	75	75	72	69	64	52
136	66	65	64	59	55	47	34
133	52	51	49	42	37	30	18
130	35	33	32	26	22	16	9
127	19	19	17	14	11	8	3
124	11	11	9	6	5	3	1
121	4	4	4	3	2	1	0
118	2	2	1	1	1	0	0

Channel 2 Negative Amplitude Output							
Input (dB)	Temperature (C)						
	-10	0	10	25	40	56	72
6	239	239	239	238	234	231	230
3	229	229	229	228	225	222	220
0	216	216	216	215	212	209	208
-3	204	204	203	202	199	196	195
-6	193	193	192	191	188	185	184
-9	184	184	183	182	179	176	175
-12	170	170	170	169	165	163	161
-15	156	156	156	155	152	149	147
-18	144	144	143	142	138	134	134
-21	133	133	132	130	126	123	123
-24	111	112	112	113	111	110	110
-27	91	93	94	96	95	95	95
-30	78	80	81	83	83	82	83
-33	57	65	70	73	72	71	73
-36	36	43	51	58	59	60	62
-39	19	24	29	36	38	37	41
-42	10	14	19	24	25	27	29
-45	4	9	11	16	16	17	21
-48	0	3	5	8	7	8	12

Channel 2 Negative Derivative Output							
Input (dB)	Temperature (C)						
	-10	0	10	25	40	56	72
172	211	209	208	205	201	197	189
169	204	203	201	198	193	189	181
166	195	193	192	189	184	180	172
163	185	183	182	179	173	168	160
160	173	172	171	168	163	157	148
157	160	158	157	153	147	141	132
154	144	142	141	137	132	127	118
151	125	123	122	120	116	111	102
148	105	105	105	103	101	96	88
145	92	90	90	89	87	83	77
142	80	80	80	79	77	74	66
139	72	72	72	70	67	62	49
136	63	62	61	57	53	46	32
133	49	48	46	40	35	28	17
130	35	34	32	26	21	16	9
127	20	19	18	13	11	7	3
124	11	10	9	6	5	3	1
121	5	4	4	2	2	1	0
118	2	2	1	1	0	0	0

Channel 2 Integral Output							
Input (dB)	Temperature (C)						
	-10	0	10	25	40	56	72
-98	250	250	250	250	248	249	248
-101	246	246	246	248	246	247	247
-104	247	247	247	248	247	248	249
-107	245	245	246	247	246	246	248
-110	244	243	244	245	244	245	246
-113	241	240	240	241	240	241	241
-116	238	237	238	238	237	237	238
-119	233	231	231	232	231	230	231
-122	228	227	227	228	226	226	227
-125	219	218	219	219	218	217	219
-128	208	207	207	208	207	207	207
-131	194	193	193	194	192	192	193
-134	179	178	178	178	176	175	175
-137	163	163	162	162	160	159	158
-140	147	146	145	145	143	143	141
-143	131	130	129	129	128	128	126
-146	115	114	114	115	114	114	112
-149	103	103	104	103	104	104	101
-152	91	90	91	90	92	91	87
-155	81	80	81	81	82	83	77
-158	66	65	66	66	68	69	64
-161	53	51	53	53	55	55	51
-164	38	39	39	37	42	40	39
-167	28	26	30	26	32	30	29
-170	24	20	22	20	24	27	19
-173	22	18	19	18	22	25	17
-176	23	19	19	18	22	25	16
-179	23	19	19	19	22	25	16
-182	22	19	19	19	22	25	16
-185	22	18	18	18	23	24	16

Channel 3 Positive Amplitude Output							
Input (dB)	Temperature (C)						
	-10	0	10	25	40	56	72
6	229	228	228	227	225	224	222
3	216	216	216	216	214	213	212
0	204	204	204	204	202	201	199
-3	192	192	192	192	190	189	187
-6	181	181	181	181	179	178	176
-9	170	169	169	169	167	166	165
-12	156	156	156	156	154	153	151
-15	141	141	141	141	139	138	137
-18	127	127	126	127	126	126	125
-21	111	113	114	116	116	116	115
-24	93	96	98	102	103	103	102
-27	79	81	83	87	88	89	89
-30	63	69	72	76	77	78	78
-33	32	40	49	62	66	68	67
-36	18	24	31	44	48	51	51
-39	6	11	16	26	29	32	33
-42	2	5	10	18	20	23	23
-45	0	1	4	11	12	16	16
-48	0	0	1	4	6	7	9

Channel 3 Positive Derivative Output							
Input (dB)	Temperature (C)						
	-10	0	10	25	40	56	72
172	220	219	217	215	211	207	201
169	211	211	209	206	201	197	190
166	206	205	204	201	197	193	186
163	195	195	194	189	185	180	172
160	184	183	182	180	175	170	161
157	168	168	166	162	157	152	142
154	154	153	151	147	142	137	127
151	134	133	132	127	123	117	108
148	115	115	114	111	107	103	94
145	98	98	98	95	92	89	82
142	86	86	86	84	82	79	71
139	78	78	77	75	72	67	55
136	68	68	66	62	58	51	37
133	53	52	51	45	40	32	21
130	35	35	33	27	23	18	10
127	21	20	20	15	13	9	4
124	11	11	10	7	6	4	1
121	6	5	4	3	2	1	0
118	3	2	2	1	1	0	0

Channel 3 Negative Amplitude Output							
Input (dB)	Temperature (C)						
	-10	0	10	25	40	56	72
6	239	239	239	237	235	232	230
3	228	228	228	227	224	222	220
0	216	216	216	215	212	211	208
-3	203	203	203	202	200	197	195
-6	191	191	191	190	188	186	184
-9	180	180	180	180	178	175	174
-12	164	165	165	165	163	161	158
-15	149	150	150	149	147	144	143
-18	136	136	135	134	133	131	130
-21	117	118	120	121	121	120	119
-24	96	99	102	106	106	107	105
-27	81	84	86	90	91	92	91
-30	63	70	75	79	80	81	80
-33	30	40	50	65	68	70	70
-36	15	23	31	45	49	53	54
-39	5	9	16	27	30	33	35
-42	1	4	9	18	21	23	23
-45	0	1	4	11	13	15	17
-48	0	3	1	5	6	7	9

Channel 3 Negative Derivative Output							
Input (dB)	Temperature (C)						
	-10	0	10	25	40	56	72
172	225	224	223	222	217	213	208
169	218	217	216	214	209	205	199
166	212	210	209	208	203	198	192
163	201	200	199	196	192	187	179
160	190	189	188	186	181	176	167
157	176	175	174	170	165	159	149
154	160	158	157	153	148	142	132
151	140	139	138	134	129	123	113
148	119	118	118	115	111	106	97
145	101	101	101	99	96	91	84
142	88	88	87	86	83	80	73
139	79	79	78	76	74	69	58
136	70	69	68	64	61	53	40
133	56	55	54	48	43	35	22
130	42	40	38	31	26	20	12
127	25	25	23	17	14	10	5
124	14	14	12	8	7	4	1
121	7	6	6	3	3	2	0
118	3	3	2	1	1	0	0

Channel 3 Integral Output							
Input (dB)	Temperature (C)						
	-10	0	10	25	40	56	72
-98	241	241	241	244	242	243	245
-101	237	237	238	240	239	240	243
-104	239	239	239	242	241	242	245
-107	237	237	237	239	239	240	243
-110	236	235	236	238	237	238	241
-113	232	231	232	234	233	235	236
-116	227	227	228	229	229	230	232
-119	220	220	220	222	221	223	224
-122	215	215	215	217	216	217	219
-125	206	206	206	208	208	209	210
-128	194	193	194	196	195	196	198
-131	179	180	180	183	182	183	185
-134	165	165	165	167	166	168	168
-137	150	150	150	152	152	152	153
-140	134	134	134	136	136	136	136
-143	119	119	120	122	121	122	123
-146	106	106	107	109	109	109	109
-149	96	97	97	98	99	99	99
-152	83	84	84	86	86	87	86
-155	73	73	75	75	76	76	76
-158	59	60	60	61	62	63	62
-161	45	46	47	47	49	50	50
-164	32	33	34	35	36	36	37
-167	21	22	23	25	26	27	27
-170	16	17	17	16	19	18	19
-173	15	16	15	16	18	18	17
-176	15	17	16	15	17	18	17
-179	15	17	16	15	17	18	17
-182	14	17	17	15	17	18	18
-185	15	17	16	15	17	18	17

Channel 4 Positive Amplitude Output							
Input (dB)	Temperature (C)						
	-10	0	10	25	40	56	72
6	223	222	222	221	218	217	218
3	211	209	209	208	206	205	206
0	198	196	196	195	193	191	192
-3	186	184	184	183	180	179	180
-6	176	174	174	172	170	168	169
-9	165	162	163	161	158	157	158
-12	149	146	146	145	144	143	143
-15	132	131	132	132	131	130	131
-18	121	120	121	122	121	120	120
-21	111	111	112	113	112	112	112
-24	94	94	97	100	100	100	101
-27	79	79	82	85	86	86	87
-30	67	68	71	74	75	75	75
-33	40	45	54	63	65	66	66
-36	23	27	36	45	49	52	53
-39	10	13	20	28	31	33	34
-42	4	7	12	19	21	23	24
-45	1	2	6	11	13	16	17
-48	0	0	1	5	7	8	8

Channel 4 Positive Derivative Output							
Input (dB)	Temperature (C)						
	-10	0	10	25	40	56	72
172	213	212	212	208	204	199	194
169	204	203	202	198	194	189	182
166	199	197	196	194	190	185	179
163	189	186	185	181	178	173	165
160	177	175	174	171	168	162	155
157	162	159	158	154	151	145	137
154	147	144	143	139	136	130	123
151	128	125	125	121	118	112	105
148	111	108	108	105	103	98	92
145	95	93	93	91	89	85	80
142	84	82	82	81	80	76	70
139	75	74	74	72	70	65	55
136	67	65	65	60	57	49	37
133	53	50	50	43	39	31	21
130	35	33	32	26	23	17	10
127	20	20	18	14	12	8	4
124	11	10	9	7	5	3	1
121	5	4	4	3	2	1	0
118	4	2	1	1	0	0	0

Channel 4 Negative Amplitude Output							
Input (dB)	Temperature (C)						
	-10	0	10	25	40	56	72
6	232	230	230	230	228	227	225
3	222	219	219	219	218	217	216
0	208	205	205	205	204	202	201
-3	193	191	191	191	190	188	187
-6	182	180	180	179	178	176	175
-9	172	169	170	169	168	166	165
-12	159	156	157	155	154	153	152
-15	145	141	141	141	140	139	138
-18	130	127	128	129	128	127	126
-21	119	118	119	120	120	119	118
-24	106	104	107	108	109	109	108
-27	90	89	91	94	95	95	95
-30	77	77	80	82	83	83	83
-33	57	59	68	72	73	73	73
-36	36	39	47	57	60	61	63
-39	18	21	27	35	39	40	41
-42	9	12	17	23	27	28	30
-45	4	12	11	16	18	19	20
-48	0	1	4	8	9	10	11

Channel 4 Negative Derivative Output							
Input (dB)	Temperature (C)						
	-10	0	10	25	40	56	72
172	216	215	214	212	206	202	195
169	208	207	205	203	197	192	186
166	202	200	199	196	192	187	180
163	192	189	188	184	180	174	166
160	181	178	177	174	170	163	155
157	165	161	161	157	152	146	137
154	149	145	145	141	137	130	122
151	129	125	125	121	118	112	105
148	109	106	107	105	102	97	91
145	94	92	92	91	89	85	79
142	82	81	81	80	78	74	67
139	74	72	72	70	68	62	51
136	63	61	61	56	53	45	33
133	48	45	44	38	35	27	18
130	33	30	30	23	21	15	9
127	19	17	17	12	11	7	3
124	11	9	8	5	4	2	1
121	4	4	4	2	2	1	0
118	2	3	1	0	0	0	0

Channel 4 Integral Output							
Input (dB)	Temperature (C)						
	-10	0	10	25	40	56	72
-98	250	246	250	250	249	249	247
-101	246	246	246	247	246	247	247
-104	247	246	247	248	247	248	249
-107	245	244	245	246	246	247	248
-110	244	243	243	244	244	244	246
-113	240	239	239	240	239	240	241
-116	238	236	236	237	236	236	238
-119	232	230	230	230	228	229	231
-122	227	225	225	226	224	224	227
-125	218	215	217	217	216	216	218
-128	206	204	205	205	205	204	206
-131	193	191	191	192	191	191	193
-134	179	176	176	177	176	175	176
-137	163	160	161	161	160	159	160
-140	147	144	144	144	143	142	143
-143	132	128	129	128	127	127	128
-146	114	112	112	113	113	112	114
-149	102	100	101	102	101	102	103
-152	88	86	87	89	88	88	90
-155	78	76	76	78	78	78	80
-158	63	60	62	63	64	63	66
-161	49	46	48	51	51	50	53
-164	35	35	35	37	38	39	42
-167	24	22	24	26	26	28	28
-170	17	16	16	19	18	19	25
-173	15	15	14	18	17	17	20
-176	16	15	15	17	16	17	23
-179	15	14	14	18	16	16	20
-182	15	15	15	18	17	15	19
-185	16	15	15	17	16	17	20

Channel 5 Positive Amplitude Output							
Input (dB)	Temperature (C)						
	-10	0	10	25	40	56	72
6	224	222	222	222	218	217	217
3	215	214	214	214	210	209	209
0	203	203	202	202	199	197	197
-3	191	191	190	190	187	186	186
-6	180	180	179	179	176	174	175
-9	171	171	170	170	167	165	165
-12	157	157	156	156	152	151	152
-15	143	142	141	141	138	137	137
-18	128	127	127	127	126	125	126
-21	116	116	117	118	117	116	117
-24	98	101	103	105	104	104	105
-27	82	85	87	90	90	90	91
-30	70	73	75	78	77	78	79
-33	43	54	63	68	68	68	70
-36	25	35	44	52	54	56	59
-39	10	18	25	33	33	35	40
-42	4	10	16	22	21	22	28
-45	1	5	9	15	11	13	20
-48	0	0	3	7	9	12	12

Channel 5 Positive Derivative Output							
Input (dB)	Temperature (C)						
	-10	0	10	25	40	56	72
172	241	239	238	235	231	227	223
169	232	230	229	226	221	217	213
166	227	225	224	221	217	213	209
163	216	214	213	210	204	200	195
160	202	201	200	197	192	188	183
157	186	185	183	180	175	169	162
154	170	168	166	163	158	153	146
151	150	149	147	143	139	134	126
148	130	129	128	125	122	117	110
145	112	111	111	108	105	101	95
142	97	97	96	95	93	89	84
139	87	87	86	85	82	79	71
136	79	78	77	74	71	64	52
133	66	66	63	57	52	44	32
130	48	47	45	38	33	26	17
127	30	29	27	21	18	13	7
124	18	17	15	11	9	6	2
121	9	8	7	5	3	2	1
118	4	3	3	2	1	1	0

Channel 5 Negative Amplitude Output							
Input (dB)	Temperature (C)						
	-10	0	10	25	40	56	72
6	233	232	232	230	228	227	224
3	223	223	223	222	219	218	215
0	210	209	209	208	206	205	203
-3	196	196	195	194	193	192	190
-6	184	183	183	182	181	179	177
-9	173	173	172	172	170	169	167
-12	159	158	158	157	156	155	154
-15	145	144	144	144	143	142	141
-18	129	130	130	131	131	130	129
-21	119	121	121	122	122	122	121
-24	105	108	110	112	112	112	112
-27	89	92	94	97	98	98	98
-30	76	79	82	84	85	85	85
-33	50	64	71	74	75	75	75
-36	27	40	50	60	64	66	67
-39	9	20	29	37	40	43	45
-42	3	10	18	25	27	29	33
-45	0	4	10	17	16	19	23
-48	0	0	3	8	8	10	14

Channel 5 Negative Derivative Output							
Input (dB)	Temperature (C)						
	-10	0	10	25	40	56	72
172	223	223	222	219	214	211	207
169	217	215	215	212	207	204	199
166	211	210	209	207	202	198	194
163	202	200	199	196	192	187	181
160	190	189	188	185	181	176	169
157	177	176	174	170	165	159	152
154	162	160	159	154	149	144	136
151	145	144	141	135	130	124	115
148	127	123	120	115	111	106	100
145	107	105	102	99	96	92	87
142	91	90	89	86	84	82	77
139	82	81	80	78	76	72	64
136	72	72	71	67	63	57	46
133	60	59	57	50	46	38	28
130	45	44	41	33	29	23	15
127	29	27	25	19	16	12	6
124	17	16	14	9	7	5	2
121	8	7	6	4	3	2	1
118	4	3	3	1	1	0	0

Channel 5 Integral Output							
Input (dB)	Temperature (C)						
	-10	0	10	25	40	56	72
-98	249	247	248	249	246	248	247
-101	242	242	243	245	244	245	246
-104	243	242	244	245	244	245	247
-107	240	240	241	243	242	243	246
-110	239	239	240	241	240	241	244
-113	236	236	237	238	237	238	240
-116	234	233	233	234	233	234	236
-119	227	226	227	228	227	227	229
-122	223	222	222	223	222	223	225
-125	216	215	216	216	215	216	218
-128	207	207	207	208	207	207	209
-131	192	192	192	193	192	193	195
-134	177	177	177	178	177	176	177
-137	162	162	162	163	162	162	163
-140	146	146	146	146	145	145	145
-143	132	131	131	132	131	131	131
-146	114	114	114	115	114	114	114
-149	102	102	103	103	103	103	103
-152	88	88	89	89	89	89	89
-155	76	76	77	77	77	77	76
-158	62	62	62	62	62	62	62
-161	48	49	49	49	49	49	49
-164	36	36	37	37	37	38	38
-167	26	27	27	28	28	28	29
-170	18	19	19	20	20	21	22
-173	12	12	12	13	13	14	15
-176	6	7	7	8	8	9	10
-179	3	3	3	4	4	5	7
-182	0	0	0	1	1	2	4
-185	0	0	0	0	0	1	2