

AD-A245 089



IMPLEMENTATION PAGE

Form Approved
OMB No. 0704-0188

1

to average 1 hour per response. Including the time for reviewing instructions, searching existing data sources, gathering and
tion of information. Send comments regarding this burden estimate or any other aspect of this collection of information, including
ices, Directorate for Information Operations and Reports, 1215 Jefferson Davis Highway, Suite 1204, Arlington, VA 22202-4302,
Project (0704-0188), Washington, DC 20503

2 REPORT DATE December 1991		3 REPORT TYPE AND DATES COVERED professional paper	
4 TITLE AND SUBTITLE THE UNIFIED NETWORKING TECHNOLOGY ADVANCED TECHNOLOGY DEMONSTRATION (UNT/ATD) NETWORKING PROTOCOLS		5 FUNDING NUMBERS PR: CHB6 PE: 0602232N WU: DN309082	
6 AUTHOR(S) C. M. Keune and C. J. Warner			
7 PERFORMING ORGANIZATION NAME(S) AND ADDRESS(ES) Naval Ocean Systems Center San Diego, CA 92152-5000		8 PERFORMING ORGANIZATION REPORT NUMBER	
9 SPONSORING/MONITORING AGENCY NAME(S) AND ADDRESS(ES) Naval Ocean Systems Center Block Programs San Diego, CA 92152-5000		10 SPONSORING/MONITORING AGENCY REPORT NUMBER	
11 SUPPLEMENTARY NOTES			
12a. DISTRIBUTION/AVAILABILITY STATEMENT Approved for public release; distribution is unlimited.		12b. DISTRIBUTION CODE	
13. ABSTRACT (Maximum 200 words) The Naval Ocean Systems Center's (NOSC) HAMA/MINCAP subnetwork architecture was demonstrated in an Advanced Technology Demonstration (ATD) in September 1990. The following subnetwork protocols were included: the Hand-off Assigned Multiple Access (HAMA) channel access protocol, the Minimum Cover Approximation (MINCAP) broadcast routing protocol, and the Backwards Learning (BL) point-to-point routing protocol. <i>Hand-off assigned multiple access</i> HAMA is an adaptive TDMA-based protocol. HAMA allows a node to temporarily hand-off a time slot to a neighbor with higher priority traffic. MINCAP uses a two hop connectivity matrix and a message history table to select relays. The three or fewer nodes which provide the best coverage of nodes who have not yet received the packet are designated as relays. BL uses a table containing delay information to each node in the network via the various relays available. The relay with the minimum path length is selected.			
14. SUBJECT TERMS command, control, and communications		15. NUMBER OF PAGES	
		16. PRICE CODE	
17. SECURITY CLASSIFICATION OF REPORT UNCLASSIFIED	18. SECURITY CLASSIFICATION OF THIS PAGE UNCLASSIFIED	19. SECURITY CLASSIFICATION OF ABSTRACT UNCLASSIFIED	20. LIMITATION OF ABSTRACT SAME AS REPORT

DTIC
SELECTED
JAN 24 1992
S B D

92-01859



92 1 22 093

Published in the *Proceedings of 1991 Canadian Conference on Electrical and Computer Engineering*, September, 1991.

UNCLASSIFIED

21a NAME OF RESPONSIBLE INDIVIDUAL C. M. Keune	21b TELEPHONE (include Area Code) (619) 553-4960	21c OFFICE SYMBOL Code 854

The Unified Networking Technology
Advanced Technology Demonstration (UNT/ATD)
Networking Protocols

Cynthia Keune and Clifford J. Warner
Naval Ocean Systems Center
San Diego CA 92152-5000

Abstract

The Naval Ocean Systems Center's (NOSC) HAMA/MINCAP subnetwork architecture was demonstrated in an Advanced Technology Demonstration (ATD) in September 1990. The following subnetwork protocols were included: the Hand-off Assigned Multiple Access (HAMA) channel access protocol, the Minimum Cover Approximation (MINCAP) broadcast routing protocol, and the Backwards Learning (BL) point-to-point routing protocol.

HAMA is an adaptive TDMA based protocol. HAMA allows a node to temporarily hand-off a time slot to a neighbor with higher priority traffic. MINCAP uses a two hop connectivity matrix and a message history table to select relays. The three or fewer nodes which provide the best coverage of nodes who have not yet received the packet are designated as relays. BL uses a table containing delay information to each node in the network via the various relays available. The relay with the minimum path length is selected.

1. Introduction

This report describes the networking protocols implemented in the Naval Ocean Systems Center's (NOSC) Unified Networking Technology Advanced Technology Demonstration (UNT/ATD) of September 1990. From 1987 to 1990, the Unified Networking Technology (UNT) research program designed and analyzed

the following protocols for a Navy battle group subnetwork: the Hand-off Assigned Multiple Access (HAMA) channel access protocol, the Minimum Cover Approximation (MINCAP) broadcast routing protocol, and the Backwards Learning (BL) point-to-point routing protocol. In September 1990, this protocol suite was demonstrated over high frequency (HF) channels in an Advanced Technology Demonstration (ATD).

Section 2 discusses the UNT/ATD objectives, and section 3 gives an overview of the demonstration testbed and scenarios. Sections 4 and 5 define the HAMA channel access and the MINCAP/BL routing protocols. Section 6 discusses current related work.

2. UNT/ATD Objectives

The primary objective of the UNT/ATD was to provide an initial demonstration of a communication system based on networking principles. The overall UNT architecture is based on a multinet concept, where a variety of users share multiple communication resources. At the individual subnetwork level, networking principles were applied to provide protocols which adapt to dynamic stressed environments, and provide improved timeliness of message delivery. The focus of the UNT/ATD was the demonstration of such a set of protocols for an HF subnetwork.

3. Testbed and Scenarios

The UNT/ATD testbed includes six nodes - five California land based nodes and a ship. The testbed is illustrated in Figure 1.

FIGURE 1. UNT/ATD TEST SITES
(Distance in Miles)

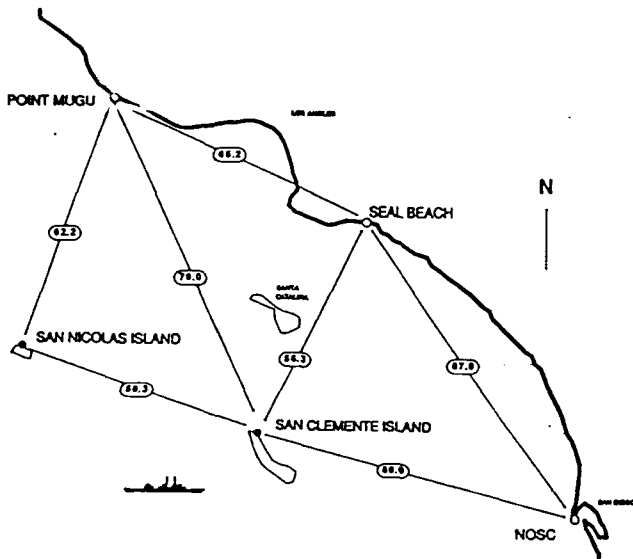

A block diagram of the hardware design at each node is shown in Figure 2. As mentioned in the previous section, the system architecture is an integrated multinetwork architecture. The architecture incorporates the following components: Subscriber Interface Units (SIUs), a Multinetwork Controller (MC), and Link Network Controllers (LNCs), all interconnected via a platform traffic distribution system. The traffic distribution system may be a Local Area Network (LAN) in some cases or merely a patch panel in others.

The SIU interfaces to the user, requests subnetwork services from the MC, and sends user data to LNCs as specified by the MC. The Multinetwork Controller is essentially the traffic cop. It dynamically assigns RF links in response to request for service from the SIUs. For each RF link, the LNC accepts data from the SIUs and

transmits it. The LNC also gathers link status information and sends it to the MC.

Figure 2
UNT ARCHITECTURE

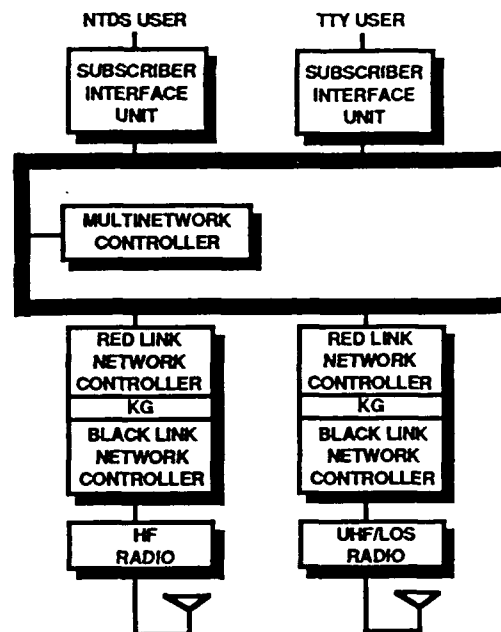

The demonstration scenarios included NTDS and record message (TTY) traffic. The NTDS traffic was broadcast traffic; the record messages were lower priority, point-to-point messages. Various traffic loadings were run. Figure 2 illustrates a node with two subnetworks, HF and UHF/LOS. Only HF was used in the UNT/ATD.

4. Channel Access Protocol

The UNT/ATD channel access protocol is Hand-off Assigned Multiple Access (HAMA). HAMA is a dynamic, time division multiple access (TDMA) protocol which has the capability to locally reallocate bandwidth. The TDMA structure of HAMA divides the channel capacity into fixed, equal length time slots. Each node owns a set of time slots, providing it with the right to transmit in those slots. If a node does not need all of its slots, the unneeded slot(s) may be handed off to a neighbor. Similarly, if a node requires more channel capacity, it

may request that slots be handed off to it. Slots are handed off to the designated node for one cycle only. Packet header information is used to control slot hand off.

In the UNT/ATD, HAMA was implemented with each node owning two adjacent time slots. The first slot was always used by the owner; the second slot could be handed off to a neighbor node. A UNT/ATD HAMA cycle is illustrated in Figure 3.

FIGURE 3. UNT/ATD HAMA CYCLE

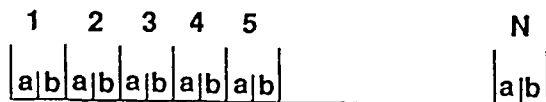

of slots = 2 N where N = No. of nodes

The handoff of a node's second HAMA slot is based on the precedence of its own queued data and its table of neighbors' requests. If there is a request for a slot to transmit data of higher precedence than the node's own data, the node hands off its second slot. The node keeps the second slot if its data has equal or higher precedence than any of its requests. The hand-off decision is made in the first slot processing, and the ID of the hand-off recipient is transmitted in the first slot.

node's request table contains each neighbor's requested number of slots and precedence level. A node requests slots for its highest precedence data only. For example, The request of a node with a queue of three messages of precedence five, five messages of precedence four, and two messages of precedence one would be for three slots at precedence five.

HAMA provides each node with guaranteed, contention free access to the communications channel. Thus, a node which is jammed or otherwise disconnected can continue to broadcast during its slots. While each node does retain slot

ownership, channel capacity can be reallocated to accommodate variable traffic patterns.

5. Routing Protocols

5.1 MINCAP The UNT/ATD broadcast routing algorithm is Minimum Cover Approximation (MINCAP). The goal of MINCAP is to deliver messages to all nodes with a limited number of relays. Relays are designated by the transmitting node. Relays are selected based on a locally maintained table of bidirectional connectivity up to two hops away, the Neighbors² Table (N2T), and a history table of which nodes have already received the message.

The N2T is built from I_Hear and Hears_Me matrices which are maintained at each node. Each node alternately transmits the list of nodes which it can hear and the list of nodes which (it has learned) can hear it. I_Hear and Hears_Me information is transmitted in the packet header. With this information a node can determine all bidirectional links within a two hop radius.

When a node receives a packet which it has been directed to relay, it determines the Potential Relay set of nodes and the Unreached Set of nodes. From the potential relay set, the best three or less relays which cover the unreached set is computed. Those nodes are directed to relay the packet.

Figure 4 contains an example of a MINCAP application. In the example, a broadcast message is generated at node 1. Node 1 must designate relays. From its N2T, node 1 knows its broadcast will reach nodes 2, 3, 4, 8, and 9. The Unreached Set of nodes is 5, 6, 7, 10, 11, and 12. The Potential Relays are all of node 1's neighbors. Nodes 3, 8, and 9 are selected as the next relays. The MINCAP algorithm will be executed at nodes 3, 8, and 9 when the packet is received. Node 8 will determine that node 11 be selected as a

relay to reach the only remaining member of the Unreached Set, node 12.

Figure 4
MINCAP BROADCAST ROUTING

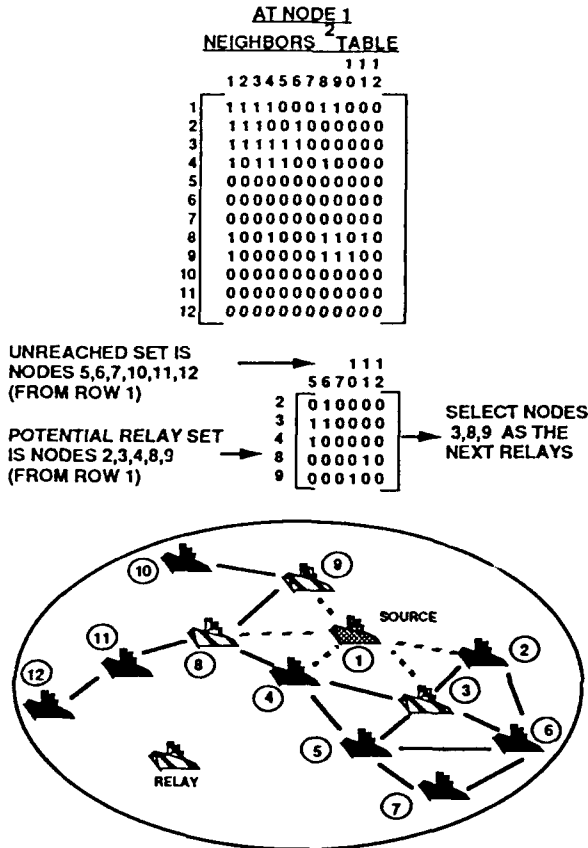
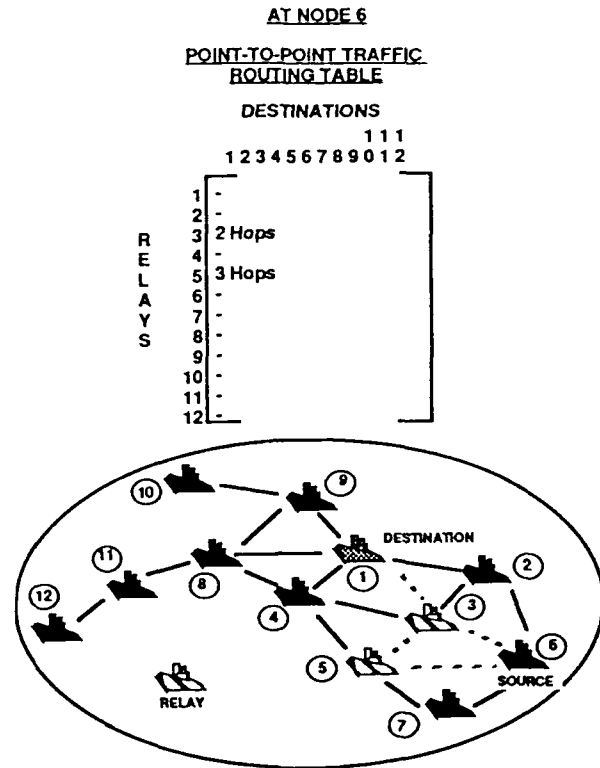

Figure 5
BACKWARDS LEARNING
POINT-TO-POINT ROUTING



6. Future

The HAMA/MINCAP subnetwork protocol suite is currently being refined and extended under the Shared Adaptive Internetworking Technology (SAINT) program. A protocol to manage dynamic network membership will be added. Modifications to HAMA which allow the allocation of more slots to advantaged platforms and other techniques for increased slot utilization are being studied.

Further demonstrations of the HAMA/MINCAP subnetwork are planned for September 1991.

5.2 Backward Learning The point-to-point routing algorithm is backwards learning. A backwards learning table is built using the number of relays incurred by a packet arriving from a given source node, via the last relay. The broadcast-routed traffic is used to build these tables. When a node receives a point-to-point packet to relay, the node searches its backwards learning table for the route with the minimum number of relays to that node.

Figure 5 contains an example of the Backwards Learning protocol. In this example, node 6 has a point-to-point message for node 1. Node 6 sees that the delay to node 1 is 2 hops via node 3 and is 3 hops via node 5. Node 3 is selected as the relay.

Accession For	
NTIS GRA&I	<input checked="" type="checkbox"/>
DTIC TAB	<input type="checkbox"/>
Unannounced	<input type="checkbox"/>
Justification	
By	
Distribution/	
Availability Codes	
Dist	Avail and/or Special
A-1	