

AD-A245 223

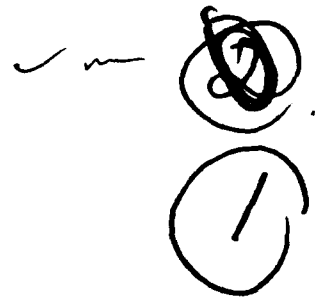

Communications Research Centre

CODE-SHIFT KEYING FOR FREQUENCY-HOPPING HF SYSTEMS WITH MULTIPATH PROPAGATION

by

G.O. Venier

(Directorate of Radio Laboratory)
(DRL)

DTIC
ELECTE
JAN 30 1992
S D D

This document has been approved
for public release and sale; its
distribution is unlimited.

92 1 29 072

CRC REPORT NO. 1437

June 1991
Ottawa

The work described in this document was sponsored by the Department of
National Defence under Tech. Base Activity 1410-041LA



Government of Canada
Department of Communications

Gouvernement du Canada
Ministère des Communications

92-02389



Canada

COMMUNICATIONS RESEARCH CENTRE

DEPARTMENT OF COMMUNICATIONS
CANADA

CODE-SHIFT KEYING FOR FREQUENCY-HOPPING
HF SYSTEMS WITH MULTIPATH
PROPAGATION

by

G.O. Venier
(Directorate of Radio Laboratory)
(DRL)



Accession For	
NTIS CRA&I	<input checked="" type="checkbox"/>
DTIC TAB	<input type="checkbox"/>
Unannounced	<input type="checkbox"/>
Justification	
By	
Distribution:	
Availability Codes	
Dist	Availability or Special
A-1	

CRC REPORT NO. 1437

June 1991
Ottawa

The work described in this document was sponsored by the Department of
National Defence under Tech. Base Activities 1410-041LA

Code-Shift Keying for Frequency-Hopping HF Systems with Multipath Propagation

G. O. Venier

ABSTRACT

Code-shift-keying systems transmitting M -ary non-orthogonal codes, and using multiple-delay correlators for demodulation, offer significant advantages over more conventional methods in HF frequency-hopping systems operating in fading multipath conditions. They can give good bit-error-rate performance with high hop rates and moderate data throughput rates, while avoiding intersymbol interference and providing diversity gain against fading when multiple paths exist. This report describes the proposed CSK technique and presents design information. A particular design is chosen for demonstration, and simulation tests of that design are described. These tests demonstrate the performance improvement of the system, in comparison with frequency-shift-keying and differential-phase-shift-keying systems, in a two-path medium in which each path has Rayleigh fading. Further work is recommended in the following areas: the investigation of trade-offs between bandwidth efficiency and performance; the improvement of code-selection and mapping algorithms to more optimally match the expected propagation conditions; the extension to multi-phase codes; and the application of trellis coding to the CSK symbols.

Manipulation par déplacement de code pour les systèmes HF à sauts de fréquence exploitant un environnement de multitrajets

G.O. Venier

RÉSUMÉ

Les systèmes de manipulation par déplacement de code (CSK) émettant des codes non-orthogonaux à M états, et utilisant des corrélateurs à retard multiples pour la démodulation, sont beaucoup plus avantageux par rapport aux méthodes plus classiques, utilisées dans les systèmes à sauts de fréquence HF exploités sous des conditions d'évanouissement par trajets multiples. Ils peuvent produire un taux d'erreurs sur les bits convenable, avec un taux élevé de sauts et un débit de données moyen, tout en évitant le brouillage intersymbole et en assurant la diversité en gain contre l'évanouissement dû à la propagation par trajets multiples. Ce rapport décrit la méthode de CSK proposée et donne des renseignements ayant trait à son élaboration. Un système particulier a été choisi pour fin de démonstration et l'auteur décrit les essais de simulation de ce système. Ces essais démontrent que la performance de ce système est meilleure par rapport aux systèmes utilisant la manipulation par déplacement de fréquence ou la manipulation par déplacement de phase différentielle, dans un milieu à deux trajets dans lequel chaque trajet est sujet à l'évanouissement de Rayleigh. On recommande de poursuivre les recherches dans les secteurs suivants: l'étude des compromis entre la performance et l'utilisation efficace de la largeur de bande; l'amélioration des algorithmes de sélection de code et d'encodage pouvant mieux s'harmoniser aux conditions de propagation prévues; l'extension aux codes multiphasés; et l'application du codage en treillis aux symboles CSK.

EXECUTIVE SUMMARY

This report describes a modulation scheme proposed for use with HF frequency-hopping systems operating in fading multipath conditions. Other more conventional schemes have serious limitations under the above conditions. Either the performance suffers from fading or intersymbol interference, or the hop rate is constrained to very low values. The proposed method, non-orthogonal M-ary code-shift keying (CSK) with demodulation by means of multiple-delay correlators, overcomes these limitations to a significant extent. It permits good bit-error rate performance with high hop rates and moderate data throughput rates while avoiding intersymbol interference and providing diversity gain against fading when there are multiple paths.

In M-ary CSK a data word (group of data bits) is represented by one of a set of code symbols comprising a sequence of phase-shift-keyed elements. The set is selected to have low cross-correlation between pairs so that they can be distinguished from each other. Orthogonal codes are usually used in CSK because they have zero cross-correlation when the symbols are perfectly synchronized. When multiple paths exist, however, the cross-correlation for non-synchronized conditions becomes important, and it is impossible to find codes for which all cross-correlations are zero. The relaxing of the requirement for orthogonality permits the selection of codes that provide higher data rates in a given bandwidth, and allows for the selection of more optimum codes for multipath conditions.

The design principles of non-orthogonal M-ary CSK are discussed and methods for the selection of good codes are presented. After this, a particular design is chosen for demonstration, and simulation tests of that design are described. These tests demonstrate the performance improvement of the system in comparison with more conventional systems when propagation is by multiple fading paths.

Areas in which further work is recommended are: the investigation of trade-offs between bandwidth efficiency and performance; the improvement of code-selection and mapping algorithms to more optimally match the expected propagation conditions; the extension to multi-phase codes (only binary-phase codes have been considered up to now); and the application of trellis coding to the CSK symbols.

Table of Contents

ABSTRACT.....	iii
RESUME.....	v
EXECUTIVE SUMMARY.....	vii
1. INTRODUCTION.....	1-1
2. SYSTEM DESCRIPTION.....	2-1
2.1 GENERAL.....	2-1
2.2 DESIGN CONSIDERATIONS.....	2-4
2.2.1 Correlation Delay Window.....	2-5
2.2.2 Code-Symbol Parameters.....	2-5
2.2.3 Selection of Codes.....	2-6
2.2.4 Mapping.....	2-11
2.2.5 Trellis Coding.....	2-14
3. SIMULATION EXPERIMENT.....	3-1
3.1 INTRODUCTION.....	3-1
3.2 DESCRIPTION OF EXPERIMENT.....	3-1
3.3 DISCUSSION OF RESULTS.....	3-4
3.3.1 Single Non-Fading Path.....	3-4
3.3.2 Single Rayleigh-Fading Path.....	3-6
3.3.3 Two Rayleigh-Fading Paths.....	3-7
4. CONCLUSIONS AND RECOMMENDATIONS.....	4-1
5. ACKNOWLEDGEMENTS.....	5-1
6. REFERENCES.....	6-1

1. INTRODUCTION

When frequency hopping is used in the HF band the phase of the signal changes randomly from hop to hop. For very slow hop rates it may be feasible to use a number of extra symbols to establish a phase reference in each hop and, therefore, to employ a coherent form of modulation such as phase-shift keying (PSK). However, when even moderate hop rates are used, there will be only a few symbols per hop, and establishment of a phase reference is not practical. For this reason, less efficient noncoherent forms of modulation such as frequency-shift keying (FSK) are usually used. An intermediate solution is the use of differentially coherent modulation such as differential PSK (DPSK). It requires one extra symbol per hop since the first symbol can act only as a reference and contains no information; it is therefore not very efficient when there are only a few symbols per hop.

A disadvantage with the use of modulation schemes such as PSK and DPSK that require more than one transmitted symbol per hop is that they are subject to intersymbol interference (ISI), while schemes such as FSK that can transmit a single symbol per hop can avoid ISI by doing so. All of the above schemes are degraded by propagation fading. Equalization can mitigate the effect of fading but generally requires a long training sequence at the beginning of each hop, and is therefore not feasible except for very low hop rates.

While binary FSK has poorer bit-error-rate performance than binary DPSK, M-ary FSK with three or more bits per symbol will actually have better performance than DPSK. It achieves this improvement, however, at the cost of bandwidth efficiency. But it should be remembered that for high hop rates the bandwidth efficiency of DPSK will also be degraded by the extra symbol required in each hop.

Another type of modulation related to FSK is code-shift keying (CSK), in which each data word is represented by a PSK-modulated code word consisting of a sequence of binary or higher-level elements. If the code symbols¹ are orthogonal the bit-error-rate performance under ideal conditions (additive white Gaussian noise (AWGN) and single path with no fading) is that of noncoherent orthogonal signals, and is therefore the same as that of noncoherent FSK with orthogonal spacing. In CSK, demodulation is performed by computation of the magnitude of the correlation of the received symbol with the reference symbols. Since only the magnitude of the correlation is used, this is a noncoherent demodulation and a phase reference is not required.

¹The term "code symbol" will be used in this report to refer to the modulated code words, ie. with elements +1 and -1 in the case of complex binary baseband signals, as opposed to elements of 0 and 1 in the unmodulated code words.

An important added advantage is that the relatively high code-element rate permits the separation of multipath components and their combination in a Rake-like system,^[1] providing diversity gain in fading conditions. Since multiple paths are combined in such a system, the delay window required to include these paths allows for frequency-hop-induced variations in the signal delay.

A requirement for orthogonal codes would result in a bandwidth efficiency comparable to that of FSK; but if a small loss in performance associated with the use of non-orthogonal codes is accepted, then better bandwidth efficiency can be obtained.

Thus, M-ary CSK modulation appears to be a good choice for HF frequency-hopping systems, allowing fairly high hop rates while providing reasonable bandwidth efficiency and maintaining good bit-error-rate performance in fading multipath conditions. Demodulation of the received signal will be more complex than for more conventional systems, but should be well within the capabilities of current digital signal processing implementations. Further improvement in performance may be possible by the use of noncoherent trellis coding of the CSK symbols. Only a very preliminary investigation of this possibility has been attempted at this time, and it is recommended as a subject for future work.

A description of the general M-ary CSK system is given in Section 2, along with a discussion of design trade-offs. Methods of searching for good codes and of mapping data words to the code words are presented. In Section 3 the results of a simulation experiment on a particular design under different propagation conditions, including multiple Rayleigh paths, are presented. The conclusions in Section 4 include suggestions for future work.

2. SYSTEM DESCRIPTION

2.1 GENERAL

The proposed CSK system uses a code of 2^N binary code words to represent data words comprising N bits of data, as shown in the example of Table 2-1. Non-binary or multi-phase codes may also be used, but in this report only binary codes will be considered. In this simple example $N = 2$, and there are, therefore, four code words to represent the 2 data bits. The code words are used to modulate a carrier with binary PSK. This process may appear to be identical to error-control coding of a binary PSK signal, but there are important differences from conventional error-control coding in the way the received signal is processed. First, the entire code symbol is processed in matched filters, and, since the receiver is to operate without a phase reference, only changes in phase between code elements are important, not absolute phase. Secondly, the matched-filter correlation is carried out at a number of delays to cover the multipath spread, and therefore cross-correlation between code symbols for these relative delays is important.

TABLE 2-1
Example of a CSK Code

Data word	CSK code word
00	1000
01	1011
10	1101
11	1110

If one code symbol is transmitted at each hop frequency there will be no intersymbol interference. But if the dwell time on each hop frequency is exactly equal to the symbol duration, some of the delayed multipath signal will be lost and the contribution from that component to a path diversity combiner will be degraded. Thus, it is advisable to make the dwell time greater than the symbol duration by at least the multipath delay spread so that received signals arriving after the end of the least delayed signal component can be fully processed.

The proposed receiver processing strategy is shown in Figure 2-1. The received signal is correlated with each of the possible code symbols j to produce correlation magnitudes at a number of delays k for each of these reference symbols. For each symbol, a combining algorithm combines the squares of the magnitudes Z_{jk} for all the delays, and the combined values are compared to determine the largest. The code word corresponding to the largest value is chosen as the one most likely to have been transmitted, and is decoded to yield the data. By adding the Z_{jk}^2 , we ensure that all the differently delayed multipath components of

a signal contribute to the value X : fed to the comparator. In contrast, a conventional matched-filter receiver would use, in each MDC, the energy in only one of the multipath components, discarding the energy in the other components. Thus, this receiver achieves diversity by exploiting multipath to increase the desired-signal energy at the decision device.

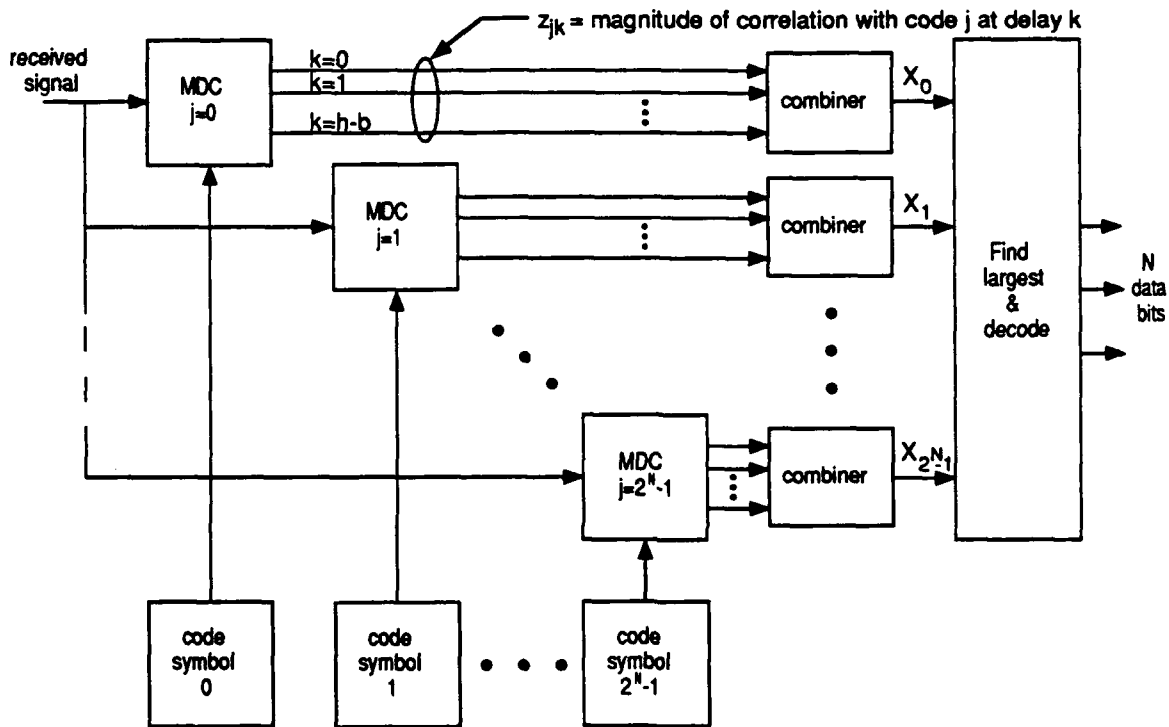

Figure 2-1 Receiver Multiple-Delay Correlator Processing System (MDC = Multiple-Delay Correlator)

The correlation is performed in the block marked MDC (multiple-delay correlator). Its operation is as follows. The input to each MDC is the received signal after it has been shifted to complex baseband and sampled. Figure 2-2 illustrates this signal with multipath. Suppose there are b samples in the original symbol time and h samples in the frequency-hop dwell time as shown. The reference code symbols are also complex baseband sampled versions of the modulated codes. Since the code elements are binary, the phases may be chosen as zero and π , making the imaginary parts zero. This simplifies the multiplication in the correlator. However, since multi-phase codes may also be of interest, the following mathematical description will consider the more general case of a complex reference.

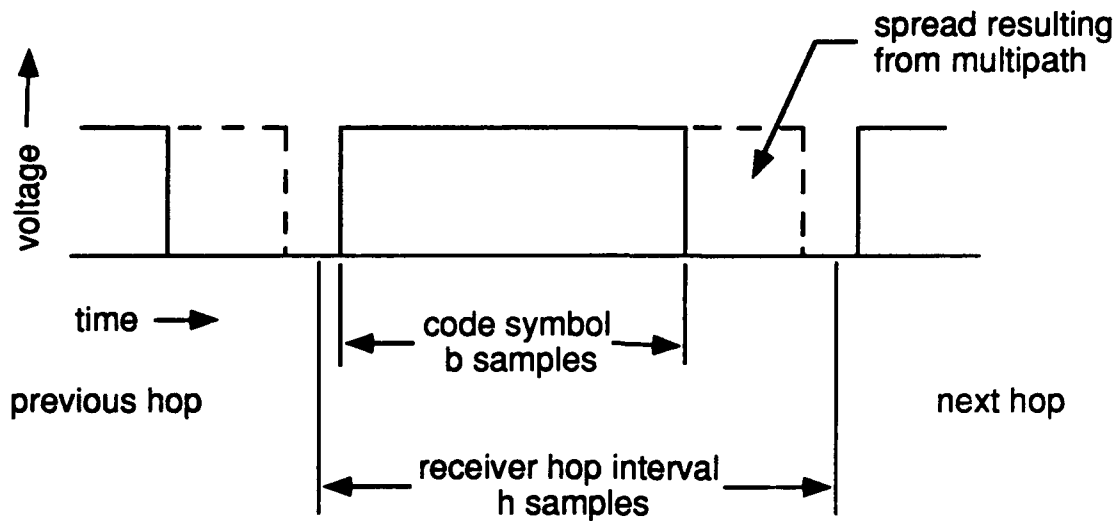

Figure 2-2 Signal Structure with Multipath Spreading

Let the input signal samples to the MDC be S_1, S_2, \dots, S_h , and the reference samples for the j th code symbol be $V_{j1}, V_{j2}, \dots, V_{jb}$. Then the output of the MDC for the j th reference symbol is the set of k correlation values Z_{jk} (k is the delay index), given by

$$Z_{jk} = \left| \sum_{i=1}^b S_{i+k} V_{ji}^* \right|, \quad k = 0, 1, \dots, h-b \quad (2.1)$$

where the * indicates the complex conjugate.

The combiner combines the correlation values for different delays to give a single output for each code symbol reference. The output of the combiner for the j th reference is given by

$$W_j = \sum_{k=0}^{h-b} [Z_{jk}]^2 \quad (2.2)$$

where $[Z_{jk}] = Z_{jk}, \quad Z_{jk} \geq T$
 $= 0, \quad Z_{jk} < T$

and if this results in $W_j = 0$, then W_j is set equal to the largest of the Z_{jk}^2 .

The result is a square-law combining of those paths that exceed some threshold T . This threshold is necessary because for most delays there will be no path, and only noise will be integrated. The argument for square-law combining is based on the assumption of a fading path for all combined inputs, and on the approximation that signal-plus-noise power is a good representation of signal power only. The threshold T can be set to some factor of the mean of the Z_{jk} averaged over all j and k . A much simpler procedure is to select the largest value of Z_{jk} for each reference j . This is equivalent to setting T to a very high value and is not far from optimum when the number of paths is small relative to the number of delays combined.

The outputs of the combiners are compared, and the data bits corresponding to the reference symbol used to generate the largest value, W_{max} , are output. Since multiple paths contribute to W_{max} , a diversity gain is realized when the individual paths are fading, but when only a single path exists there will be a loss relative to a conventional system synchronized to that path.

All paths with delays falling within the correlation window of $h-b+1$ samples can contribute to the signal energy. This window simplifies the delay synchronization task since the window delay need be set only to include most of the multipath. Tracking of this window can be accomplished by computing the "centre of gravity" of the sample energy in the window and moving the centre of the window toward it. If the correction is based on some fraction of the error, the resulting "inertia" of the window will help prevent loss of track by noise and interference.

2.2 DESIGN CONSIDERATIONS

In the design of a particular system there are a number of important values that need to be determined. These are the code-symbol parameters (number of bits encoded in a CSK code symbol and the number of binary elements in a code symbol), the size of the correlation delay window (i.e. the time in excess of the transmission time in each hop interval to allow for the multipath spread), and the particular CSK code (code-word set) to be used. It is assumed here that the code-element rate is already determined by the allowable transmission bandwidth. A code-element rate of 80% of the bandwidth should be achievable with careful element shaping. This would give, for example, a code-element rate of 2400

elements per second in a 3-kHz channel bandwidth². A sample rate sufficient to prevent aliasing of the code-element spectrum is assumed.

2.2.1 Correlation Delay Window

The correlation delay window should be large enough to include a significant portion of the multipath components, but since this window requires extra time in which there is no transmission, it should be kept as small as possible to maintain a high data throughput rate. As well, too large a window can degrade performance since noise power from all parts of the window contributes to symbol errors. The disadvantage of a window that is too small is that some of the multipath energy that could be used to increase the diversity is lost. Thus the probability distribution of multipath spread must be taken into account in deciding on the window size. This will, of course, depend on the particular link that the system is to be used for. In general, larger multipath spreads are expected for shorter links, but such factors as the terrain over the link may be important since it may determine the number of significant hops that can exist. Also, time of day can be a factor since certain ionospheric layers may occur only at certain times. In a digital system the window size could easily be changed according to conditions. Windows in the range of 1/2 to 2 milliseconds should accommodate most conditions. The basic time-delay resolution of a code symbol at a 2400-element-per-second rate is about 0.4 ms, and this translates into from two to six possible independent paths. A higher element rate would provide better resolution but would require a larger transmission bandwidth.

2.2.2 Code-Symbol Parameters

For orthogonal codes and a single path in AWGN the bit-error-rate performance will improve as the number of bits encoded in a transmitted symbol is increased. However, if orthogonality is to be maintained, as a rule the length of the code symbol will increase more rapidly than the number of bits encoded, thus reducing the bandwidth efficiency. Although it is proposed that in this system the requirement for orthogonality be abandoned, the rule still applies for a given level of cross-correlation, and it is important to keep the cross-correlation as low as possible. This means that increasing the number of bits per symbol in the proposed system requires either a reduction in bandwidth efficiency or a performance loss, resulting from the greater cross-correlation, that may negate the gain otherwise expected from the increase in the number of bits per symbol. As well, an increase in the length of

²This figure may be somewhat optimistic. Simulation tests to be described later assume this is possible but filtering was not used in the simulation to constrain the transmitted bandwidth. After the tests were performed, further analysis has indicated that such tight filtering may cause degradation in performance, and it may be necessary to reduce the data rate from the values simulated if the transmit bandwidth must be limited to 3 kHz.

the symbols will reduce the hop rate, and will make processing more difficult. Code symbols of three data bits and six code elements have been found to give reasonably good performance. It has not been determined whether this ratio of one-half bit per code element can be maintained for larger symbols, but it should certainly be possible to improve bit-error-rate performance with four- or five-bit code symbols by using lower ratios with their lower bandwidth efficiency. Further investigation is required before more accurate estimates can be made.

Another subject that deserves investigation is the feasibility of the use of multi-phase codes to increase the degrees of freedom for a given code-symbol length. By this means it may be possible to increase bandwidth efficiency without sacrificing performance.

2.2.3 Selection of Codes

Once the code-symbol parameters have been determined there is still the problem of finding the best code with those parameters and testing its performance to see if it is satisfactory. If it is not, it will be necessary to change one or both of the above parameters and try again. A method of finding the best code with a given number of codes words of a given length is discussed below.

When only a single path is present and a correlation delay window of only one sample (normal synchronized system) is used, the main criterion for bit-error-rate performance is that the code symbols have low cross-correlation at zero relative delay. It is assumed here that a phase reference is not available so that only the magnitude of the correlation is important, and not its phase. When the zero-delay cross-correlation is zero for all code-symbol pairs the code is said to be orthogonal. If N bits are encoded in each code symbol then orthogonality requires at least 2^N code elements. For example, three-bit code symbols require eight elements.

Autocorrelation and cross-correlation sidelobes (i.e. correlation magnitudes at non-zero delay) are not important under the above conditions. However, when there are multiple paths the correlation sidelobes will have an effect, particularly when a large correlation window is used to provide path diversity.

Cross-correlation sidelobes cause a loss in performance because the decision on the transmitted symbol is based on an integration over the delay window and therefore the correlators for incorrect symbols will produce non-zero values, even without noise, thus reducing the effective distance³ between symbols.

³The term "effective distance" as used in this report is not the Euclidean distance. It is intended to be a measure of the separation between symbols, averaged over different multipath conditions. In contrast to Euclidean distance, it is based on the assumption of non-coherent demodulation (magnitude of matched-filter output), and takes into account the possibility of delay differences between the symbols.

Cross-correlation at zero relative delay is, of course, at least as important as any cross-correlation sidelobe within the delay window.

Autocorrelation sidelobes cause a loss in performance because they reduce the isolation between multipath components; the sidelobe of one component can interfere destructively with the main lobe of another.

An ideal code would have zero cross-correlation between all code-symbol pairs for all delays, and zero autocorrelation for all delays, except of course for zero delay. Unfortunately this is not possible for codes with symbols of reasonable length. The longer the symbols, the more degrees of freedom that are available to aid in approaching this ideal. But, as mentioned above, symbols must be kept short to allow high bandwidth efficiency. Of course, if a high data rate is not very important longer symbols should be used to improve performance.

For the purpose of finding good codes, a search method is proposed in which all possible codes are tried and the best one selected. To allow this it is necessary to devise a function that measures the quality of the code so that the best one can be identified.

Suppose the number of bits, N , to be encoded in each code symbol, and the number of elements, L , in each are given. Then there will be 2^L possible code symbols to choose from. But half of these will be inversions of the others, and since absolute phase is not important, there are really only $K = 2^{L-1}$ different code symbols to choose from. To represent N bits, $M = 2^N$ code symbols will be needed. There are $K!/(M!(K-M)!)$ ways of choosing the M code symbols provided that the order is not important. (While the order is important when assigning the code symbols to the data words, a method of reordering them with a separate mapping operation will be considered later. In fact it would be better to combine the code and mapping searches, but this would be difficult and would not likely be worth the effort.)

As an example, if $N = 3$ and $L = 6$, then $K = 32$ and $M = 8$. This means that the number of possible codes is $32!/(8!24!) = 10,518,300$. In fact this number can be reduced by eliminating from the 2^{L-1} code symbols those that have high autocorrelation function sidelobes. In the example above, of the 32 code symbols, 14 symbols have maximum sidelobes of $2/6$, 14 have maximum sidelobes of $3/6$, 2 have maximum sidelobes of $4/6$, and 2 have maximum sidelobes of $5/6$. Allowing only the lowest two sidelobe levels of $2/6$ and $3/6$ reduces the number of code symbols to 28, and the number of different codes to 3,108,105.

To search for good codes it is necessary to have an algorithm that will compute the quality of each code, based on the cross-correlation and autocorrelation

functions of its symbols. The code with the highest quality can then be selected. Good codes will have symbols with low cross-correlation magnitudes and low autocorrelation sidelobes (magnitudes for non-zero delays). However, there are some difficulties in establishing the relative importance of the various characteristics. For example: What is the relative importance of the autocorrelation and cross-correlation values? And, should correlation values at greater delays be given less weight than those at smaller delays, and if so, what should the weighting function be?

Of course these questions cannot be answered with any accuracy unless a complete statistical model of the propagation conditions is known. For example, the best code for two propagation paths with a particular delay difference will not be best for two paths with another delay difference, or for a different number of paths. But it should be possible to select a code which is a compromise, and has reasonably good performance for all expected conditions.

While it may be possible to define a propagation model which combines many of the expected conditions, and develop a selection strategy that is in some sense optimal for that model, this does not appear to be a worthwhile endeavour at this point. All that work would only assure optimality for conditions described by that particular model, and at HF it would be extremely difficult to determine a realistic model. Propagation conditions change with time of day, time of year, position within the sunspot cycle, latitude, path length, etc.

Thus, a more intuitively based method for code selection is proposed, which takes into account the expected range of conditions, but with no claim of optimality. This method is based on the following assumptions.

1. When there is no multipath, autocorrelation function sidelobes are of little importance, but cross-correlation values for all delays within the correlation window are important, since these values can add to produce a large correlation for the wrong code symbols, and thus they decrease the effective distance between symbols.
2. When there is multipath both autocorrelation sidelobes and cross-correlation values for all delays are important, but the cross-correlation is more serious. Autocorrelation sidelobes from one delay can fall on the main peak of another delay with possible destructive interference. But since this depends on the position of the lobes relative to the delay difference between paths, and on the relative phase of the paths, the effect is to increase the probability of low energy in the correct detector and is of only moderate importance. However, all the cross-correlation values from each path that fall within the window can add to the energy in the wrong detector and thus have a very

serious effect on the effective distance between symbols. Cross-correlation values are thus considered to be more important than autocorrelation ones, and also to be a more serious problem under multipath conditions than under single-path ones.

3. Correlation sidelobes at larger relative delays are, on the average, less important than at smaller delays. This is because it is assumed that the probability of the existence of delayed paths generally decreases with delay, and also that the probability of the sidelobes falling within the window is less for greater delays.
4. The importance of correlation magnitude is a function that is stronger than linear. That is, if one value is twice another one it will be more than twice as important.

Based on the above assumptions, the following search strategy is proposed. It involves some arbitrary decisions that are based more on intuitive reasoning than on solid mathematical analysis. More careful analysis when time permits will probably result in improvements. But it is thought that the proposed algorithm will provide reasonably good codes that will suffice to verify the advantages of this type of system.

The method is to test all possible codes of a given number of code symbols of a given length. For example, suppose, as in the example mentioned above, it is desired to use a code of 8 symbols to represent 3 bits of data and that the length of the symbols is 6 elements. Also, as in that example, suppose that 4 of the 32 available 6-element binary code symbols have been eliminated because of their poor autocorrelation functions. Then it will be necessary to test all sets of 8 out of the 28 symbols. A simple way to find these sets is to set up a binary counter with 28 bits, increment the count by one starting at zero, test the Hamming weight of the number in the counter (the number of ones in it), and use all binary numbers with weight 8 as a mask to define a code. That is, the positions of the ones in the counter determine which of the 28 code symbols to use. For much larger sets this method would be rather slow. It would be better to use loops, one for each of the symbols in the set (8 in the example), to place the ones in all of the possible positions (28 in the example).

When a code has been found it is tested for "badness" as explained in the following description (the less the badness, the better the code). First, determine the cross-correlation magnitude for each symbol pair for relative delays of integer numbers of elements. Let the magnitude of the cross-correlation between symbols i and j for relative delay d be X_{ijd} . Compute the weighted sum of the lobes for this pair as

$$y_{ij} = \sum_{d=-L+1}^{L-1} w^{|d|} (x_{ijd})^p, \quad (2.3)$$

where L is the length of the code symbol, d is the relative delay in code elements, p is a power constant, greater than one, that is intended to emphasize the larger sidelobes, and w is a weight decay constant, less than one, that determines the rate of decay of the weights with increasing delay magnitude.

The choice of p will depend on the threshold for integration in the correlation window. A large threshold will effectively result in a selection of the largest lobe, and, therefore, requires a large p . But even in this case different sidelobes from different paths will add before this thresholding so that smaller sidelobes should not be ignored. Since the relative phase between different paths is expected to be random, addition will be on a power basis on average indicating that p should be at least 2. But since only those sidelobes occurring at the same delay will add, it seems reasonable to use a p greater than 2 to further emphasize the larger lobes. A p of 4 has been arbitrarily chosen for our tests which were designed for a high-integration-threshold system. Further study on the choice of the constant p would be worthwhile.

The value chosen for w depends on the importance assigned to the sidelobes, and this, in turn, depends on the probabilities of various relative propagation delays. In tests, which will be described later, where relatively long-range skywave propagation and a code-element rate of 2400 per second have been assumed, a w of 0.8 was used. This gives a weighting of about one-half to sidelobes separated by 3 code elements (1.2 milliseconds) from the zero-delay value. This choice of 0.8 was rather arbitrary, and with more time and some study of propagation statistics, a better choice could undoubtedly be made.

An overall badness for this set of M code symbols, based only on the cross-correlation properties, is then computed by summing the above correlation sums for all $M(M-1)/2$ code-symbol pairs as follows.

$$B_x = \sum_{i=1}^{M-1} \sum_{j=i+1}^M y_{ij} \quad (2.4)$$

As was mentioned earlier, the autocorrelation function sidelobes are also important, although less so, and so these should also affect the badness determination. A similar method using the same weighting function and power can be used to compute an autocorrelation function badness factor B_a , which can be

multiplied by the cross-correlation factor B_x to produce an overall badness number B_o . B_o can be made less sensitive to the autocorrelation values by including in B_a a fractional power constant, f . If A_{jd} is the autocorrelation magnitude of code symbol j at delay d , then the badness, B_a , is found from

$$B_a = \left[\sum_{j=1}^{M-1} \sum_{d=1}^{L-1} (A_{jd})^p \right]^f. \quad (2.5)$$

In our tests $p = 4$ and $f = 1/4$ were chosen, again rather arbitrarily.

The overall badness number is, then,

$$B_o = B_x B_a. \quad (2.6)$$

Testing of all possible codes with this algorithm will yield a ranking, and those with the least badness can be selected as good candidates.

An alternative method of combining the two badnesses is by addition as shown in equation 2.7.

$$B_o = B_x + k B_a. \quad (2.7)$$

where k represents the relative importance of the autocorrelation badness.

2.2.4 Mapping

Each CSK symbol represents N data bits. When an error occurs in a symbol one or more bits will be in error, depending on the combination of the transmitted symbol and the received symbol. The bit error rate will be minimized if the most likely symbol errors result in the fewest bit errors. This means that the CSK symbol pairs with the greatest cross-correlation (minimum effective distance) should correspond to data-word pairs that differ in only a single bit, while those with least cross-correlation should correspond to data-word pairs differing in all their bits. But since there is not independence between pairs, the task of mapping data words to CSK symbols is not a simple one. Complicating the process further is the problem of determining a reasonable measure of cross-correlation or effective distance when the probabilities of multipath levels and delay separations are unknown. A method based on the same ideas as those used in determining search algorithms for codes is proposed as a start.

First the errors must be determined for all sets of data-word pairs. These can

be presented as a matrix, E , where the elements, e_{ij} , represent the number of bit errors between the words i and j . An example for 3-bit words will illustrate this. The data words are 000, 001, ..., 111. Then the error matrix is as follows (only the upper triangle is required since $e_{ij} = e_{ji}$ and $e_{ii} = 0$).

$$E = \begin{bmatrix} - & 1 & 1 & 2 & 1 & 2 & 2 & 3 \\ - & - & 2 & 1 & 2 & 1 & 3 & 2 \\ - & - & - & 1 & 2 & 3 & 1 & 2 \\ - & - & - & - & 3 & 2 & 2 & 1 \\ - & - & - & - & - & 1 & 1 & 2 \\ - & - & - & - & - & - & 2 & 1 \\ - & - & - & - & - & - & - & 1 \\ - & - & - & - & - & - & - & - \end{bmatrix}$$

As an example, if word 010 ($i=3$) is transmitted and word 100 ($j=5$) is received the first two bits will be in error and so the entry for row 3 and column 5 is 2. For words representing N bits there will be $M = 2^N$ words, and the triangular matrix will have $M(M-1)/2$ elements.

The matrix gives the cost of a symbol error. Another matrix, P , can be defined, whose element p_{ij} is the probability of CSK symbol i being demodulated as CSK symbol j . Then the best mapping of data words to CSK symbols can be defined as the one that minimizes the overall cost. As with E , only an upper triangular matrix is required. The overall cost, then, is

$$C = \sum_{i=1}^{M-1} \sum_{j=i+1}^M e_{ij} p_{ij} \quad (2.8)$$

An estimate of the probability p_{ij} can be determined from the correlation between the two symbols i and j as follows. Consider the effective signal-to-noise ratio, SNRE, defined as that signal-to-noise ratio which for orthogonal signals would give the bit error rate of the non-orthogonal pair considered. SNRE will be proportional to the square of the effective distance between the two code symbols, and the effective distance will be related to the correlation between them. Because the correlation at different delays is important, a definition of correlation, R_{ij} , as shown in equation 2.9 can be defined that takes this into account in a way similar to that used in equation 2.3.

$$R_{ij} = \frac{1}{L} \left[\sum_{d=1}^{L-1} w^{|d|} |x_{ijd}|^p \right]^{1/p} \quad (2.9)$$

But in this case, since the result is to be a correlation, a fractional power, $1/p$, has been used after the summation to compensate for the power p that was used before summation to emphasize the larger lobes. A normalizing factor $1/L$ is also included so that the correlation will be one when the code symbols are the same. In fact this will give a correlation slightly greater than one for the same symbols since there will also be a small contribution from the correlation sidelobes, but this will normally be small as a result of the power p that makes the largest correlation peak dominate.

To get the probability of symbol error, p_{ij} , it is assumed that the relative effective distance between symbols can be represented by $1-R_{ij}$, and that the probability of symbol error is an exponential function of SNRE, and therefore of the effective-distance squared as in equation 2.10.

$$p_{ij} = A \cdot \exp\left[-k(1-R_{ij})^2\right] . \quad (2.10)$$

The constant, A , is of no consequence since, as can be seen from equation 2.8, it will be a constant factor in the cost and will not affect the relative cost; it will therefore be set to one. This leaves only the constant k to be determined, and this can be done by selecting a reasonable operational symbol error rate such as 10^{-3} for the ideal orthogonal case ($R=0$), and solving for k . It has been found that the relative cost is not very sensitive to k , and therefore not sensitive to the chosen error rate either. For the above error rate $k = 6.9$, and equation 2.10 becomes

$$p_{ij} = \exp\left[-6.9(1-R_{ij})^2\right] . \quad (2.11)$$

The error matrix, E , and equations 2.8, 2.9 and 2.11 define the overall cost function.

Once a good code has been found, the best mapping can be determined by trying all possible mappings and computing the cost function for each. The mapping resulting in the lowest cost should then be chosen as the best one. A mapping consists of pairing each data word with a CSK code word, and determines the indexing of the elements of P relative to the fixed indexing of E . For a set of M code words there will be $M!$ different pairings to be tested. If the data words are taken in their natural order, $0, 1, \dots, M-1$, and the CSK code words are identified by the numbers 1 to M , then a mapping is an ordering of the M code-word numbers with the understanding that data word 0 is mapped to the first code-word number, 1 is mapped to the second, etc. This ordering may be represented by a vector of length M that will be called the mapping vector.

2.2.5 Trellis Coding

Improvement in performance is possible with the addition of error-control coding. This will usually lead to a reduction of bandwidth efficiency since it involves the addition of redundant symbols. However, with trellis coding the redundancy can be added by means of an increase in the size of the set of possible symbols, without an increase in bandwidth. Error performance is improved by imposing constraints on the possible sequence of transmitted symbols (defined by the trellis structure), and by making decisions based on a part of the received sequence, rather than on one symbol at a time. While an increase in the symbol-set leads to decreased minimum effective distances between symbols, it is the minimum effective distance between sequences that is important, and this is made greater than the original symbol minimum effective distance in order to reduce the bit error rate.

Ideally, the symbols should be coherent to permit maximum gain from the sequence detection. But trellis coding can also be applied to noncoherent symbols (only the magnitude of each symbol detection is used) like those of CSK. If N bits are encoded into $M = 2^{N+1}$ CSK symbols, there will be twice as many symbols as required to represent the N bits and a trellis code can be applied. Code-symbol pairs with large effective distance (low cross-correlation) can be chosen to correspond to parallel paths on the trellis (ones from the same node that merge again after only a single symbol), while pairs with small effective distance can be made to correspond to paths that do not merge until after two or more symbols. The object is to maximize the minimum effective distance between any two paths that leave a common node and then merge again at another node after one or more symbols.

The use of trellis coding will complicate the selection of codes. Different criteria will be required, that recognize the importance of having some symbols of very large effective distance (for the parallel paths) at the cost of other symbols with small effective distance that will have less impact on the bit error rate because they are on a longer path. The selection and mapping of the CSK code and the trellis code should be performed in conjunction, if possible, since they are interdependent. The investigation of this problem, and the determination of the performance gain that can be achieved with trellis coding, are important subjects that are proposed for future work.

3. SIMULATION EXPERIMENT

3.1 INTRODUCTION

The DRL Spread-Spectrum Simulator was used to investigate the performance of a particular CSK design and compare it with the performance of FSK and DPSK systems having the same data rate under various propagation conditions. This simulator is a software simulator developed at DRL, which permits the simulation of transmitter, propagation path, noise and interference, and receiver. Various types of modulation, coding, and spread-spectrum techniques are available in the simulator, as are routines for bit-error analysis.

3.2 DESCRIPTION OF EXPERIMENT

Simulation experiments were carried out for a system designed to operate in a bandwidth of about 3 kHz while using a fairly high hop rate and moderate data rate. The parameters of the simulated system are given in Table 3-1.

TABLE 3-1

Parameter	Value
CSK code element rate	2400/s
no. of elements in a code symbol, L	6
code-symbol duration	2.5 ms
hop rate	300/s
no. of data bits per code symbol, N	3
data rate	900 b/s
combiner integration threshold, T	20 x mean
system sample rate	9600/s

The combiner integration threshold shown was intended to make the combining algorithm a simple one of selection of the largest correlation value. The presence of correlation sidelobes and noise in the window increases the value of the mean. Thus, the likelihood of any correlation value exceeding twenty times the mean becomes very small and, as explained in Section 2, when none of the values exceeds the threshold the largest is selected as the combiner output.

The simulation is not in real time; the sample rate shown is not that of the simulator, but that of the simulated sampled system. With this sample rate there will be four samples per modulation symbol.

The hop rate of 300 hops per second means a hop duration of 3.333 ms. Since the code symbol duration is only 2.5 ms there will be a delay window of 0.8333 ms (9 samples). While this may be a little small for short paths it should be adequate for paths of 2000 km or more. A larger window may be desirable for more reliable tracking, though. The ratio of code-symbol duration to hop duration is 0.75. Of course, a larger window can be obtained by decreasing the hop rate and thus reducing this ratio. This will also reduce the data throughput rate unless the number of bits per symbol is increased to compensate. In any case, the simulated system is not intended as a final design, but only as an example to demonstrate the performance of this type of system.

The code shown in Table 3-2 was selected for the simulated system. This code is the best one found using the search strategy described in section 2.3 with a weight decay constant $w = 0.8$, a power constant $p = 4$, and a fractional power constant $f = 1/4$. A mapping vector found by the search method described above was used to determine the order of the code words in the table. A w of 0.8 and a p of 4 were also used in this search.

Table 3-2
Code used in Simulated System

data word	code word
000	100100
001	111001
010	111110
011	101000
100	100001
101	110101
110	100111
111	100010

The path delays used in the simulation tests were always centred in the correlation delay window. That is, when a single path was used the receiver delay was set to put it at the centre of the window, and when two paths were used the receiver delay was set so that they were equal distances on either side of the centre of the window. Although the 8CSK system had the capability for delay tracking, this was not used in these performance tests. The tracking capability was tested separately, however, and found to work well provided that the tracking time constant was large enough so that when one path faded the window would not move too far before it reappeared. If a smaller time constant is necessary to accommodate rapid delay changes, a window of twice the delay spread should prevent the loss of a fading path.

The tracking system was not intended to correct for delay changes between frequencies – the delay window allows for that – but rather to compensate for drifts in the average delays caused either by changing propagation conditions or by clock drifts.

Two other more conventional systems with the same data rate were also tested for comparison. These were noncoherent 8-ary FSK (8FSK), and differential binary PSK (DBPSK). All systems transmitted 3 bits per hop; in the case of 8CSK and 8FSK this meant one symbol per hop, while for DBPSK four binary symbols containing three data bits were transmitted per hop. The extra binary symbol was required for the initial phase reference since it was assumed that coherence could not be maintained over a frequency change.

For the DBPSK system a dead time of 0.8333 ms was added at the end of each group of four symbols in a hop interval to allow for delay variations between frequencies. That is, the dwell time at each frequency was 25% longer than the active transmission. This is the same as for the 8CSK transmission. With the same hop rate as the 8CSK system, the bandwidth for the 900 bit-per-second data rate would be two-thirds that of the 8CSK bandwidth since four binary symbols are transmitted in the same period as the 6 binary elements of the CSK code symbol. Therefore, the DBPSK signal could be transmitted in a 2-kHz bandwidth. In the simulation no filtering was used in any of the systems to constrain the transmitted bandwidth, although this would be necessary in a real system. As noted in a footnote in Section 2.2, the filtering necessary to constrain the transmitted bandwidth of the 8CSK waveform to 3 kHz may degrade the system's performance. This problem, which was not foreseen when the simulation experiment was designed, may require some reduction in data rate if the 3-kHz constraint is to be maintained. Further investigation of the effects of filtering will be necessary to determine the magnitude of the reduction.

In the simulation it was assumed that the DBPSK signal was always perfectly synchronized to the path with least delay. That is, the receiver delay was set to the correct delay for this path and there were no variations in delay between frequencies. This will likely result in optimistic performance estimates.

For the 8FSK system no transmission dead time was used since the longer symbol interval is much less sensitive to delay errors. Thus the symbol occupied the full hop dwell interval, or eight times the 8CSK code-element duration. But there were eight tone slots separated by the inverse of the symbol duration, and this resulted in the overall bandwidth being essentially the same as that of the 8CSK transmission.

As with the DBPSK simulation, perfect synchronization with the least-delayed path was assumed. However, with its longer symbol duration the 8FSK system would not be as sensitive to delay variations, and therefore the performance estimates would be a little less optimistic than those for DBPSK.

Simulation tests were performed under a number of different propagation conditions but always with AWGN. The propagation conditions used in the tests were as follows: a single non-fading path; a single Rayleigh-fading path; two Rayleigh-fading paths of equal amplitude, each having a 3-Hz fading rate; and two Rayleigh-fading paths of equal amplitude, each having a 10-Hz fading rate. The rather high fading rates were chosen because of possible applications in polar and auroral regions where disturbed ionospheric conditions are often found. The delay difference between paths was 0.625 ms for most of the tests with multiple paths, but tests were also performed with differences from 0.1 to 0.83 ms. Path conditions were identical at all frequencies in the hop set, but phase was random from hop to hop.

Rayleigh fading was simulated at complex baseband. The fading rate was determined by a two-pole Butterworth lowpass filter used to filter the Gaussian noise that determines the path gain. Fading rate is defined here as the 3-dB cut-off frequency of the lowpass filter. Although this filter is a low-pass design, it can be considered to be a complex bandpass filter at zero centre frequency with bandpass equal to twice the cut-off frequency.

The bit energy E_b referred to in each test is taken as the total of the average bit energy from all paths used in the particular test. The noise power density, N_0 , is taken as the noise power divided by the sample rate, since the noise generator generates independent samples whose spectrum is uniform over the sample bandwidth.

3.3 DISCUSSION OF RESULTS

3.3.1 Single Non-Fading Path

The tests with a single non-fading path were intended to determine the performance degradation of the CSK system resulting from using a non-orthogonal code and the combining algorithm (the combining can result only in a loss under ideal conditions as opposed to an expected gain for multipath conditions). Without these degradations the 8CSK system has performance identical to that of the 8FSK system. The degradation due to combining can be avoided by reducing the window to a single sample. A test with this condition is included to isolate other degradations.

Figure 3-1 is a plot of the results of the single-path non-fading tests. The solid and dashed lines show the theoretical performance of 8FSK and DBPSK systems respectively. The DBPSK curve is displaced 1.25 dB to the right relative to the usual DBPSK curve because, for the assumed frequency-hopping design, four symbols must be sent in each hop to carry 3 bits of information. Thus the bit energy is 4/3 times that of an un-hopped DBPSK system.

Simulation results are shown for the 8CSK system. The asterisks show the performance for the design indicated in Tables 3-1 and 3-2 above. The error bars indicate the 90% confidence limits. The correlation peak for the single path was centred in the 0.83-ms delay window. These points indicate that the loss resulting from the combining algorithm and the non-orthogonality of the code is a little more than 2 dB.

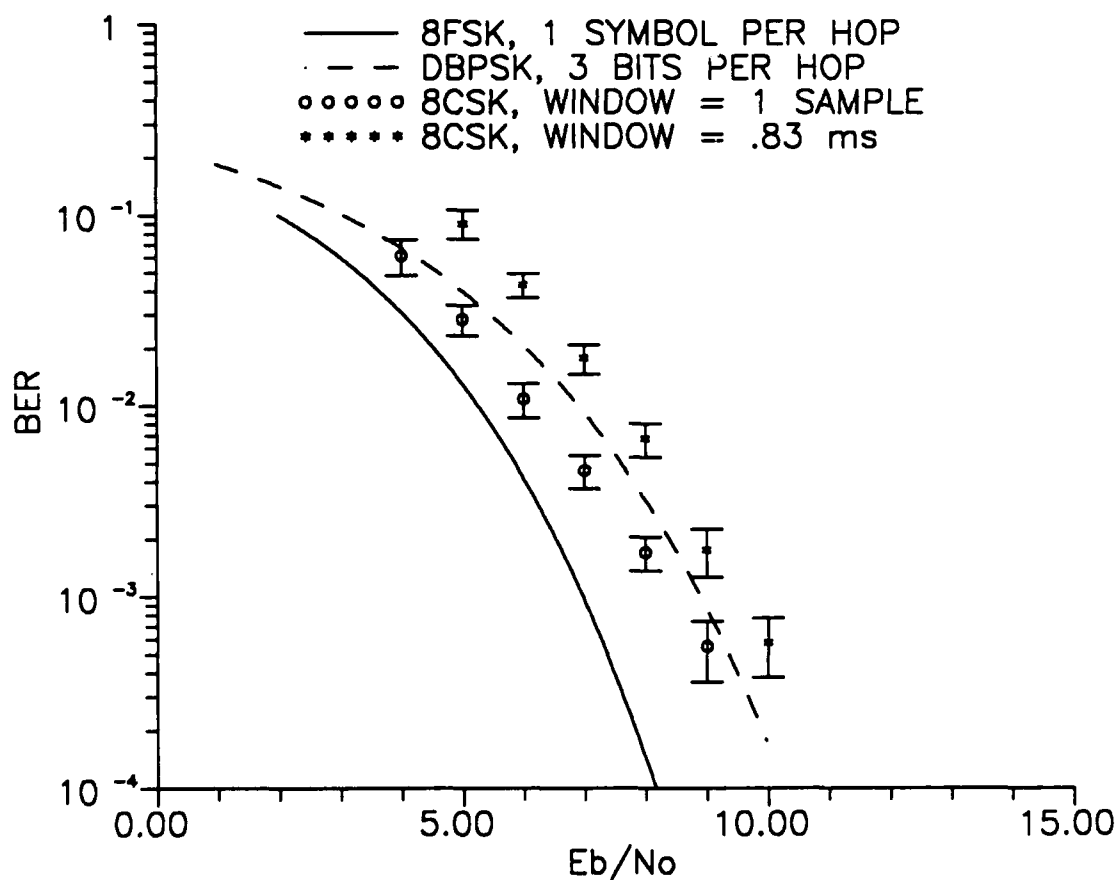

Figure 3-1 Performance of 8FSK, DBPSK, & 8CSK for Single Non-Fading Path

The circles in Figure 3-1 show the performance when the delay window is reduced to a single sample with perfect synchronization. This reduces the loss to about 1 dB, indicating that the non-orthogonality loss and the combining loss are each about 1 to 1.5 dB.

3.3.2 Single Rayleigh-Fading Path

Figure 3-2 shows the results for a single Rayleigh-fading path. This time the 8FSK and DBPSK curves are from simulation tests in which ideal matched-filter detection was used. These agree very well with the theoretical values (well within 1 dB) except for the last point of the DBPSK curve at 32 dB which appears to be affected by the 3-Hz fading rate (the theoretical analysis that was used for the comparison assumes a low fading rate that does not affect the error rate). This indicates that the simulation is accurate for 8FSK and DBPSK. The performance of these two systems is almost identical except at high signal-to-noise ratio where the DBPSK system is more sensitive to the phase variations (Doppler frequency) associated with the 3-Hz fading rate. This sensitivity to phase variations could be reduced a little by increasing the DBPSK data rate by 50%, to the maximum possible for a 3-kHz channel.

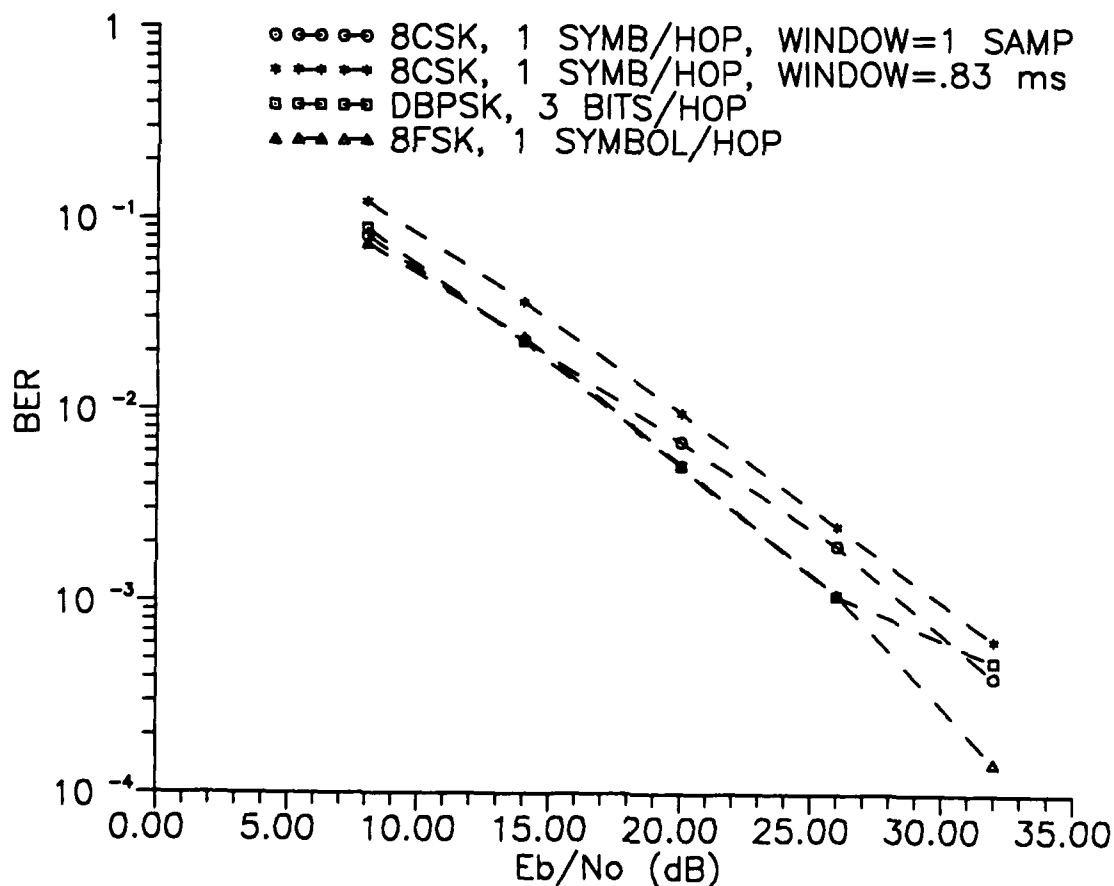
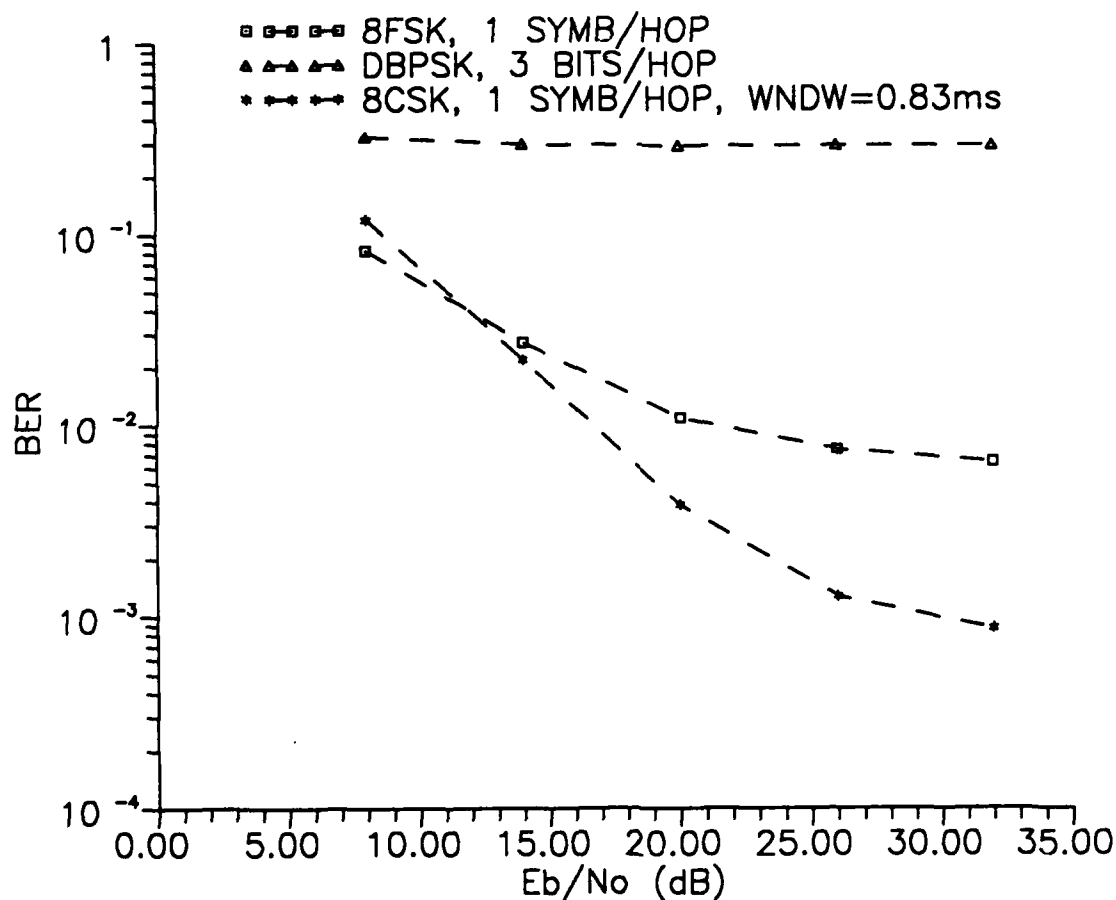

Figure 3-2 Performance of 8FSK, DBPSK, & 8CSK for Single Rayleigh-Fading Path, Fading Rate = 3 Hz

The bit-error rate is plotted in Figure 3-2 for the CSK system with the normal window of 0.83 ms as well as for the system with a synchronized one-sample window. As expected with a single path, there is a loss relative to the more conventional systems of up to 2 dB for the single-sample window and of 2 to 3 dB for the larger window. Although no flattening of the curves is evident at high signal-to-noise ratio, it is likely that at the 3 Hz fading rate some flattening would occur a little beyond the highest signal-to-noise ratio plotted.



4
 Figure 3-3 Performance of 8FSK, DBPSK, & 8CSK for Two Equal-Power Rayleigh-Fading Paths, Fading Rate = 3 Hz
 10

3.3.3 Two Rayleigh Fading-Paths

In Figure 3-3 a second Rayleigh-fading path, delayed from the first by 0.625 ms but with the same average power and fading rate (3 Hz), has been added. The bit energy used on the horizontal axis is the total energy in the two paths. It can be seen that the performance of the DBPSK system has been seriously degraded by the

intersymbol interference. The 8FSK system does not fare quite so badly because it uses a longer symbol. The 8CSK system with the 0.83-ms window provides much better performance because of its ability to separate the multipath components and combine them in a diversity operation. The improvement relative to 8FSK increases with signal-to-noise ratio, but the plot begins to bottom out as the error rate drops below about 4×10^{-4} , no doubt as a result of the fading rate.

Figure 3-4 shows the result when the fading rate was increased to 10 Hz. The performance of the DBPSK system has degraded even further, but that of the 8FSK system has not changed significantly; the fading rate is still not high enough to disturb the noncoherent demodulation process. The degradation of the CSK system performance has been increased by the higher fading rate, but even at this very high fading rate, the bit error rate is lower than that of the 8FSK system except at very high error rates (above about .05).

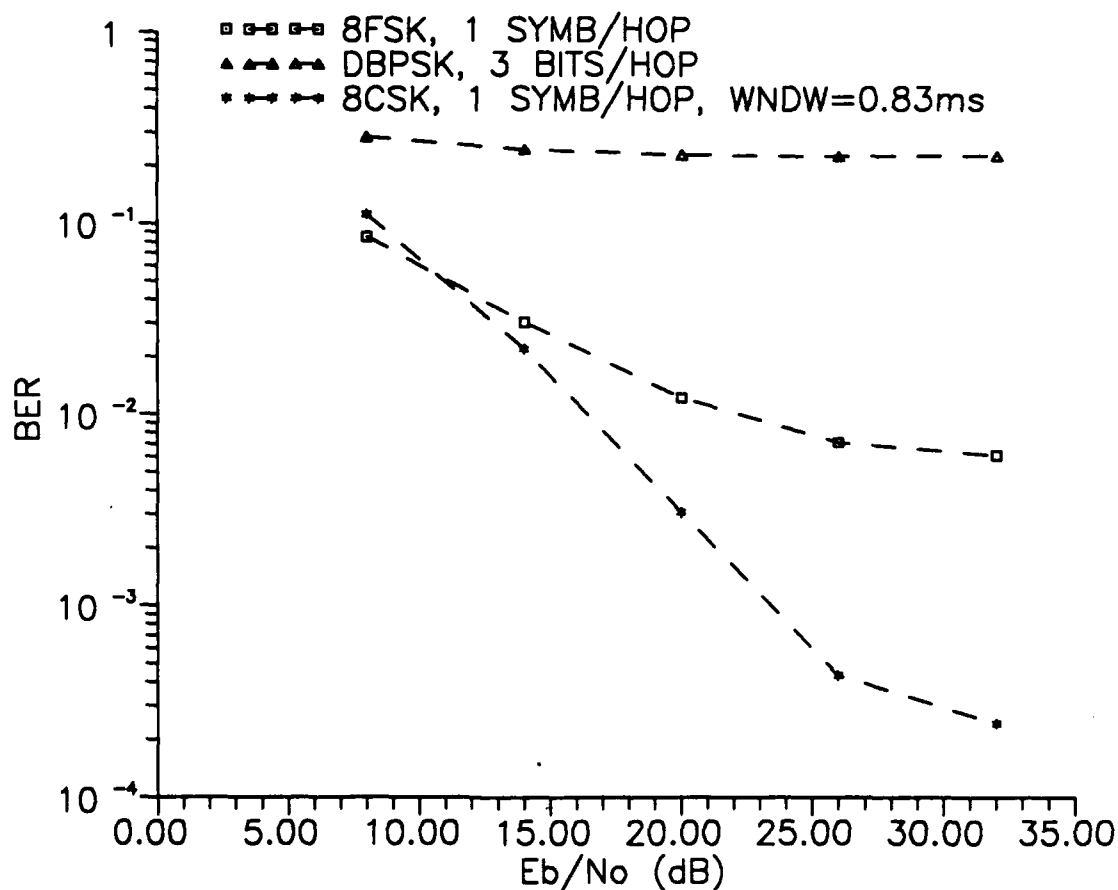

3
 Figure 3-4 Performance of 8FSK, DBPSK, & 8CSK for Two Equal-power Rayleigh-Fading Paths, Fading Rate = 10 Hz
 3

The effect of the delay separation between two Rayleigh-fading paths was investigated with the simulator, and the results are presented in Figure 3-5. Delay separations from 0.1 to 0.8 ms were tested with a fading rate of 3 Hz and a signal-to-noise ratio (E_b/N_0) of 26 dB.

With zero separation (a single Rayleigh-fading path) the 8CSK system has slightly poorer performance than the others, as was already demonstrated in Figure 3-2. The 8FSK system degrades slowly and in a linear fashion with delay separation because, even for the greatest separation, the delay difference is a small fraction of the symbol duration. The DBPSK system, on the other hand, has a much shorter symbol of about 0.8 ms, and therefore intersymbol interference, and thus error rate, increases more rapidly with delay difference. As the delay approaches a full symbol the degradation flattens out and drops slightly beyond that value. It is to be expected that a delay difference of one symbol would be the worst case, since for this delay all of the delayed symbol will interfere with the next symbol; for delays greater than this the interference is split between the next two symbols, each thereby being less affected.

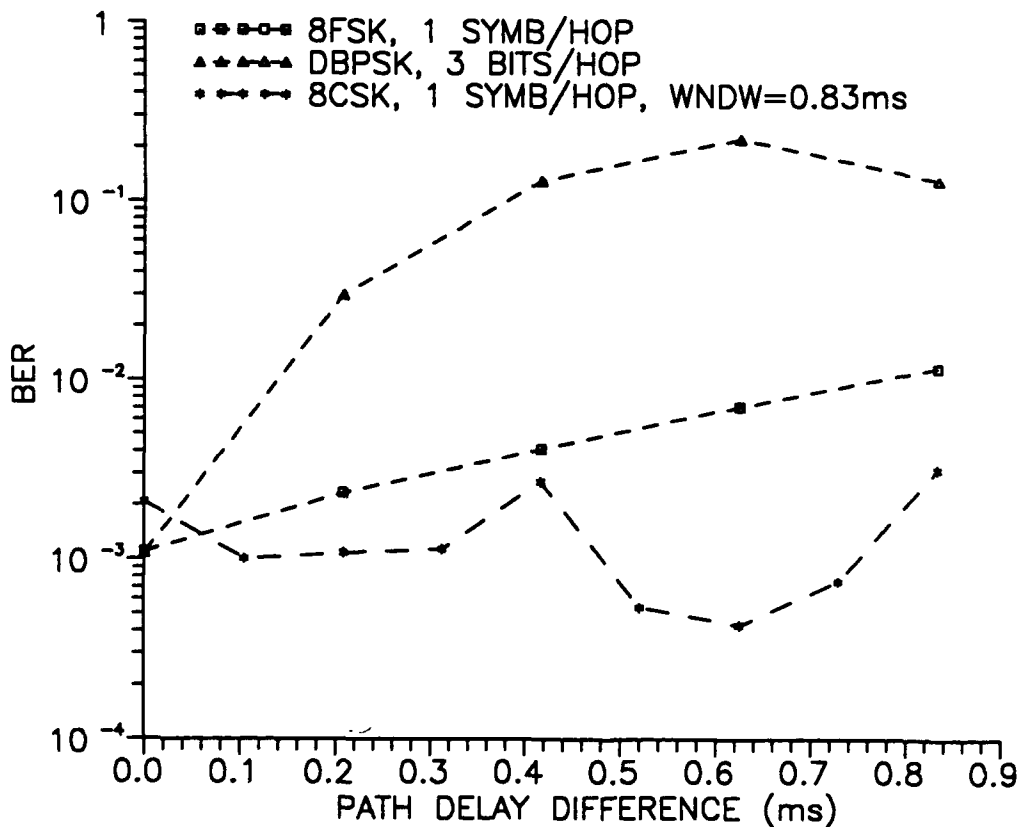

Figure 3-5 Performance of 8FSK, DBPSK, & 8CSK for Two Equal-Power Rayleigh-Fading Paths as a Function of Delay Difference, Fading Rate = 3 Hz

Except for a cyclic variation with delay difference, the 8CSK system performance is fairly constant. It has bit-error-rate maxima at zero and at multiples of the code-element duration (about 0.4 ms). At these multiples the effect of the correlation sidelobes is maximized because each sidelobe is largest for integer code-element delays. At a delay difference of one code element the improvement for the 8CSK system over that of the 8FSK one is small, but averaged over all reasonable delay differences the improvement is significant.

4. CONCLUSIONS AND RECOMMENDATIONS

Non-orthogonal M-ary code-shift keying with demodulation by means of multiple-delay correlators is an alternative modulation scheme offering significant advantages for HF frequency-hopped communications systems requiring high hop rates and moderately high data rates while operating in fading multipath conditions. The design of such systems has been investigated and methods for finding good codes have been presented.

Simulation tests of a frequency-hopped 8-ary CSK system indicated significant improvement in bit-error-rate performance over that of 8-ary FSK and DPSK systems, for the case of two Rayleigh-fading paths.

The effect, on CSK performance, of transmitter filtering necessary to control the transmission bandwidth should be investigated. This will determine the data rate possible in a given channel bandwidth.

The criteria for code selection and mapping to data words need refining to better match them to expected propagation conditions. Also, further investigation is required to determine the trade-offs between bit-error-rate performance and data-throughput rate as influenced by the choice of number of bits per code word and word length.

The study should be extended to the case of non-binary CSK codes, that is, to codes whose symbols have elements that can have more than two phases. These multi-phase codes may allow a better trade-off between bit-error-rate performance and bandwidth efficiency.

An investigation of the application of trellis coding to the CSK symbols is strongly recommended. New code-selection algorithms that combine the selection and mapping of the CSK code and the trellis code will have to be developed.

5. ACKNOWLEDGEMENTS

I wish to acknowledge the contributions of Stewart Crozier and Andy Tenne-Sens in their respective tasks of reviewing and editing this report. Their very competent work added to the quality of the report, and was much appreciated.

The Work described in this Report was performed under Department of National Defence Tech. Base Activity 0892-15149.

6. REFERENCES

- [1] Price, R. and P. E. Green Jr., *A Communication Technique for Multipath Channels*, Proceedings of the IRE, vol. 46, pp. 555-570, March 1958.

DOCUMENT CONTROL DATA

(Security classification of title, body of abstract and indexing annotation must be entered when the overall document is classified)

1. ORIGINATOR (the name and address of the organization preparing the document. Organizations for whom the document was prepared, e.g. Establishment sponsoring a contractor's report, or tasking agency, are entered in section 8.) COMMUNICATIONS RESEARCH CENTRE DEPARTMENT OF COMMUNICATIONS OTTAWA, ONTARIO K2H 8S2		2. SECURITY CLASSIFICATION (overall security classification of the document including special warning terms if applicable) UNCLASSIFIED	
3. TITLE (the complete document title as indicated on the title page. Its classification should be indicated by the appropriate abbreviation (S,C or U) in parentheses after the title.) CODE-SHIFT KEYING FOR FREQUENCY-HOPPING SYSTEMS OPERATING IN HF MULTIPATH (U)			
4. AUTHORS (Last name, first name, middle initial) VENIER, GERALD, O.			
5. DATE OF PUBLICATION (month and year of publication of document) JUNE 1991	6a. NO. OF PAGES (total containing information. Include Annexes, Appendices, etc.) 36	6b. NO. OF REFS (total cited in document) 1	
7. DESCRIPTIVE NOTES (the category of the document, e.g. technical report, technical note or memorandum. If appropriate, enter the type of report, e.g. interim, progress, summary, annual or final. Give the inclusive dates when a specific reporting period is covered.) CRC REPORT #1437			
8. SPONSORING ACTIVITY (the name of the department project office or laboratory sponsoring the research and development. Include the address.) DEFENCE RESEARCH ESTABLISHMENT (DREO) 3701 CARLING AVENUE OTTAWA, ONTARIO K1A 0Z4			
9a. PROJECT OR GRANT NO. (if appropriate, the applicable research and development project or grant number under which the document was written. Please specify whether project or grant) 1410-041LA		9b. CONTRACT NO. (if appropriate, the applicable number under which the document was written)	
10a. ORIGINATOR'S DOCUMENT NUMBER (the official document number by which the document is identified by the originating activity. This number must be unique to this document.) CRC REPORT NO. 1437		10b. OTHER DOCUMENT NOS. (Any other numbers which may be assigned this document either by the originator or by the sponsor)	
11. DOCUMENT AVAILABILITY (any limitations on further dissemination of the document, other than those imposed by security classification) (X) Unlimited distribution () Distribution limited to defence departments and defence contractors; further distribution only as approved () Distribution limited to defence departments and Canadian defence contractors; further distribution only as approved () Distribution limited to government departments and agencies; further distribution only as approved () Distribution limited to defence departments; further distribution only as approved () Other (please specify):			
12. DOCUMENT ANNOUNCEMENT (any limitation to the bibliographic announcement of this document. This will normally correspond to the Document Availability (11). However, where further distribution (beyond the audience specified in 11) is possible, a wider announcement audience may be selected.)			

13. **ABSTRACT** (a brief and factual summary of the document. It may also appear elsewhere in the body of the document itself. It is highly desirable that the abstract of classified documents be unclassified. Each paragraph of the abstract shall begin with an indication of the security classification of the information in the paragraph (unless the document itself is unclassified) represented as (S), (C), or (U). It is not necessary to include here abstracts in both official languages unless the text is bilingual).

CODE-SHIFT KEYING SYSTEMS TRANSMITTING M-ARY NON-ORTHOGONAL CODES, AND USING MULTIPLE-DELAY CORRELATORS FOR DEMODULATION, OFFER SIGNIFICANT ADVANTAGES OVER MORE CONVENTIONAL METHODS IN HF FREQUENCY-HOPPING SYSTEMS OPERATING IN FADING MULTIPATH CONDITIONS. THEY CAN GIVE GOOD BIT-ERROR-RATE PERFORMANCE WITH HIGH HOP RATES AND MODERATE DATA THROUGHPUT RATES, WHILE AVOIDING INTERSYMBOL INTERFERENCE AND PROVIDING DIVERSITY GAIN AGAINST FADING WHEN MULTIPLE PATHS EXIST. THIS REPORT DESCRIBES THE PROPOSED CSK TECHNIQUE AND PRESENTS DESIGN INFORMATION. A PARTICULAR DESIGN IS CHOSEN FOR DEMONSTRATION, AND SIMULATION TESTS OF THAT DESIGN ARE DESCRIBED. THESE TESTS DEMONSTRATE THE PERFORMANCE IMPROVEMENT OF THE SYSTEM, IN COMPARISON WITH FREQUENCY-SHIFT-KEYING AND DIFFERENTIAL-PHASE-SHIFT-KEYING SYSTEMS, IN A TWO-PATH MEDIUM IN WHICH EACH PATH HAS RAYLEIGH FADING. FURTHER WORK IS RECOMMENDED IN THE FOLLOWING AREAS: THE INVESTIGATION OF TRADE-OFFS BETWEEN BANDWIDTH EFFICIENCY AND PERFORMANCE; THE IMPROVEMENT OF CODE-SELECTION AND MAPPING ALGORITHMS TO MORE OPTIMALLY MATCH THE EXPECTED PROPAGATION CONDITIONS; THE EXTENSION TO MULTI-PHASE CODES; AND THE APPLICATION OF TRELLIS CODING TO THE CSK SYMBOLS.

14. **KEYWORDS, DESCRIPTORS or IDENTIFIERS** (technically meaningful terms or short phrases that characterize a document and could be helpful in cataloguing the document. They should be selected so that no security classification is required. Identifiers, such as equipment model designation, trade name, military project code name, geographic location may also be included. If possible keywords should be selected from a published thesaurus. e.g. Thesaurus of Engineering and Scientific Terms (TEST) and that thesaurus-identified. If it is not possible to select indexing terms which are Unclassified, the classification of each should be indicated as with the title.)

CODE-SHIFT-KEYING
MODULATION
HF
MULTIPATH
FREQUENCY HOPPING
SPREAD SPECTRUM
ECCM
FADING
CORRELATOR
DIGITAL
RAKE
DIVERSITY