

Report No. CG-D-01-92

u

2

**AN EVALUATION OF THE VERTICAL SECTOR
LIGHT REQUIREMENTS FOR UNMANNED BARGES**

AD-A245 239



Michael L. Fisher

U.S. Coast Guard
Research and Development Center
1082 Shennecossett Road
Groton, Connecticut 06340-6096

DTIC
SELECTE
JAN 30 1992
S B D



**FINAL REPORT
MARCH 1991**

DISTRIBUTION STATEMENT A
Approved for public release;
Distribution Unlimited

This document is available to the U.S. public through the
National Technical Information Service, Springfield, Virginia 22161

Prepared for:

U.S. Department Of Transportation
United States Coast Guard
Office of Engineering, Logistics, and Development
Washington, DC 20593-0001

92-02230



92-02230

NOTICE

This document is disseminated under the sponsorship of the Department of Transportation in the interest of information exchange. The United States Government assumes no liability for its contents or use thereof.

The United States Government does not endorse products or manufacturers. Trade or manufacturers' names appear herein solely because they are considered essential to the object of this report.

The contents of this report reflect the views of the Coast Guard Research and Development Center, which is responsible for the facts and accuracy of data presented. This report does not constitute a standard, specification, or regulation.



**SAMUEL F. POWEL, III
Technical Director**

**U.S. Coast Guard Research and Development Center
Avery Point, Groton, Connecticut 06340-6096**



Technical Report Documentation Page

1. Report No. CG-D-01-92		2. Government Accession No.		3. Recipient's Catalog No.	
4. Title and Subtitle An Evaluation of the Vertical Sector Light Requirements for Unmanned Barges				5. Report Date March 1991	
				6. Performing Organization Code	
7. Author(s) Michael L. Fisher				8. Performing Organization Report No. R&DC 11/91	
9. Performing Organization Name and Address U.S. Coast Guard Research and Development Center 1082 Shennecossett Road Groton, Connecticut 06340-6096				10. Work Unit No. (TRAVIS)	
				11. Contract or Grant No.	
12. Sponsoring Agency Name and Address Department of Transportation U.S. Coast Guard Office of Engineering, Logistics, and Development Washington, D.C. 20593-0001				13. Type of Report and Period Covered FINAL REPORT	
				14. Sponsoring Agency Code	
15. Supplementary Notes This work was performed as part of the Signal Effectiveness Project, 2704.					
16. Abstract A study was conducted to determine whether or not navigation safety is affected by the size of the vertical sector of navigation lights on unmanned barges. Off-the-shelf equipment was purchased and tested to ascertain the performance of existing lighting equipment against COLREGS requirements. The purpose served by vertical sector was defined, and a "minimum" luminous intensity distribution was created as a standard against which off-the-shelf and COLREGS lights could be judged. An analysis was performed to determine the power requirement for a COLREGS light. None of the off-the-shelf equipment tested met the COLREGS specification. Some exceeded the "minimum" luminous intensity distribution with up to a 1.5 degree margin for error. The COLREGS luminous intensity distribution provided a 4.5 degree margin for error. The power needed to meet all of the requirements of the COLREGS is feasible, but not easy to produce with batteries.					
17. Key Words vertical sector navigation lights barge lights COLREGS			18. Distribution Statement Document is available to the U.S. public through the National Technical Information Service, Springfield, Virginia 22161		
19. Security Classif. (of this report) UNCLASSIFIED		20. SECURITY CLASSIF. (of this page) UNCLASSIFIED		21. No. of Pages	22. Price

METRIC CONVERSION FACTORS

Approximate Conversions to Metric Measures

Symbol	When You Know	Multiply By	To Find	Symbol
LENGTH				
in	inches	* 2.5	centimeters	cm
ft	feet	30	centimeters	cm
yd	yards	0.9	meters	m
mi	miles	1.6	kilometers	km
AREA				
in ²	square inches	6.5	square centimeters	cm ²
ft ²	square feet	0.09	square meters	m ²
yd ²	square yards	0.8	square meters	m ²
mi ²	square miles	2.6	square kilometers	km ²
	acres	0.4	hectares	ha
MASS (WEIGHT)				
oz	ounces	28	grams	g
lb	pounds	0.45	kilograms	kg
	short tons (2000 lb)	0.9	tonnes	t
VOLUME				
tsp	teaspoons	5	milliliters	ml
tbsp	tablespoons	15	milliliters	ml
fl oz	fluid ounces	30	milliliters	ml
c	cups	0.24	liters	l
pt	pints	0.47	liters	l
qt	quarts	0.95	liters	l
gal	gallons	3.8	liters	l
ft ³	cubic feet	0.03	cubic meters	m ³
yd ³	cubic yards	0.76	cubic meters	m ³
TEMPERATURE (EXACT)				
°F	Fahrenheit temperature	5/9 (after subtracting 32)	Celsius temperature	°C

* 1 in = 2.54 (exactly).

Approximate Conversions from Metric Measures

Symbol	When You Know	Multiply By	To Find	Symbol
LENGTH				
mm	millimeters	0.04	inches	in
cm	centimeters	0.4	inches	in
m	meters	3.3	feet	ft
m	meters	1.1	yards	yd
km	kilometers	0.6	miles	mi
AREA				
cm ²	square centimeters	0.16	square inches	in ²
m ²	square meters	1.2	square yards	yd ²
km ²	square kilometers	0.4	square miles	mi ²
ha	hectares (10,000 m ²)	2.5	acres	
MASS (WEIGHT)				
g	grams	0.035	ounces	oz
kg	kilograms	2.2	pounds	lb
t	tonnes (1000 kg)	1.1	short tons	
VOLUME				
ml	milliliters	0.03	fluid ounces	fl oz
l	liters	0.125	cups	c
l	liters	2.1	pints	pt
l	liters	1.06	quarts	qt
l	liters	0.26	gallons	gal
m ³	cubic meters	35	cubic feet	ft ³
m ³	cubic meters	1.3	cubic yards	yd ³
TEMPERATURE (EXACT)				
°C	Celsius temperature	9/5 (then add 32)	Fahrenheit temperature	°F

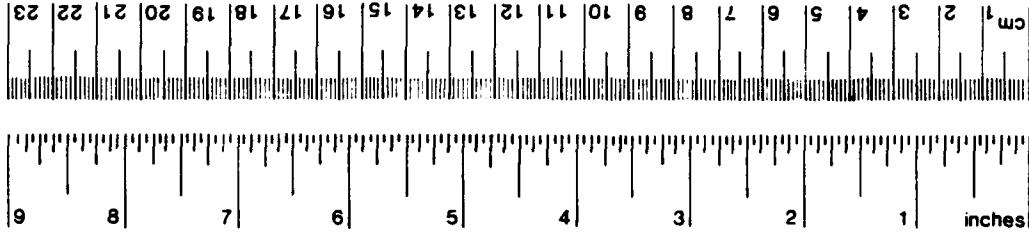
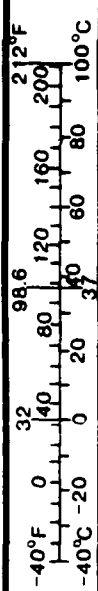

TABLE OF CONTENTS

	<u>Page</u>
1.0 INTRODUCTION	1 ,
2.0 BACKGROUND	1
3.0 TASK 1 - TECHNICAL CHARACTERISTICS OF OFF-THE-SHELF EQUIPMENT	2
3.1 BACKGROUND	2
3.2 METHOD	2
3.3 RESULTS	4
4.0 TASK 2 - OPERATIONAL PERFORMANCE	4
4.1 BACKGROUND	4
4.2 METHOD	5
4.3 RESULTS	7
4.3.1 Theoretical Distribution For Height Of Eye Differences	7
4.3.2 Analysis Of Aiming Errors	7
4.3.3 Margin Of Error Of COLREGS Light	9
4.3.4 Margin Of Error Of Off-The-Shelf Lights ...	9
5.0 TASK 3 - TRADE-OFFS	9
5.1 BACKGROUND	9
5.2 METHOD	11
5.3 RESULTS	11
5.3.1 Battery Powered Lights	13
5.3.2 Solar Powered Lights	13
6.0 CONCLUSIONS	14
7.0 RECOMMENDATIONS	15
APPENDIX A - Vertical Sector Requirements for Unmanned Barges Operating in COLREG Waters	A-1
APPENDIX B - Sample Data from Off-the-Shelf Equipment .	B-1



Accession For	
NTIS GRA&I	<input checked="" type="checkbox"/>
DTIC TAB	<input type="checkbox"/>
Unannounced	<input type="checkbox"/>
Justification	
By _____	
Distribution/	
Availability Codes	
Dist	Avail and/or Special
A-1	

LIST OF FIGURES

<u>Figure</u>		<u>Page</u>
1a	Vertical Sector	3
1b	Vertical Sector of ± 5 Degrees from Horizontal	3
2	COLREGS Vertical Sector Profile	3
3a	Triangle Relationship of Vertical Angle, Height of Eye, Horizontal Distances, and Light Path Distance	6
3b	Luminous Intensity Required For 100 Ft Height of Eye ...	6
4	Minimum Distributions For 50, 100, and 200 Ft Height of Eye	8
5	Comparison of COLREGS and Minimum Luminous Intensity Distributions	8
6a	Comparison of Off-The-Shelf and Minimum Luminous Intensity Distributions	10
6b	Comparison of Off-The-Shelf and Minimum Luminous Intensity Distributions	10
7	Comparison of Gaussian and COLREGS Luminous Intensity Distributions	12

1.0 INTRODUCTION

The Coast Guard has known for several years that lights used on unmanned barges do not meet the International Rules of the Road (COLREGS) requirements for minimum luminous intensities in the vertical sector. Unmanned barges do not have an integral source of power, and thus barge operators must rely on battery powered lights. Small, portable batteries that are preferred by the barge industry do not have the capacity to power lights which meet the COLREGS for extended periods. Manufacturers have reduced the light intensity in the vertical sector in order to conserve power.

The Coast Guard has recognized this problem in the design of unmanned barge lights, and has relaxed the requirements in Inland waters. Unmanned barges operating in Inland waters must only meet the requirements for the minimum luminous intensity on the horizontal. There is no requirement that the lights have any vertical sector. The barge industry has asked the Coast Guard to consider recommending to the International Maritime Organization (IMO) that the COLREGS be amended to grant this same exemption for unmanned barges operating in international waters.¹

The Coast Guard has decided to review its policy on vertical sector requirements for unmanned barges. A study was performed at the Coast Guard Research and Development Center to determine how a reduction in vertical sector requirements affects the safety of navigation. This study was also directed at determining the design and cost constraints on battery powered lights to assess the feasibility of designing battery powered lights that meet the COLREGS. The study was conducted specifically to: (1) measure the technical characteristics of off-the-shelf battery powered navigation lights to determine how close they were to meeting the COLREGS; (2) determine the reduction in operational performance if the current luminous intensity requirements are reduced; and (3) determine the trade-offs among increased luminous intensity, power requirements, and cost. This report describes the results of this effort.

2.0 BACKGROUND

The vertical sector of a navigation light is the range of vertical angles over which light is emitted (Figure 1a). In order for an observer to see a navigation light at a distance, the observer must be within the vertical sector, and close enough to the light such that the light is intense enough to be detected (within the luminous range). Figure 1b shows a light with a

¹ A detailed background is available from the Navigation Safety Advisory Committee (NAVSAC) Report (C-2) of their November 1989 meeting in Seattle, Washington, and is included as Appendix A. A subcommittee was specifically formed to consider vertical sector requirements for unmanned barges operating in COLREG waters.

vertical sector of ± 5 degrees (deg). An observer located on a vessel at position A, 2.5 nautical miles (NM) from this light, is within the vertical sector and within the luminous range of the light, and therefore can see it. An observer at position B, possibly an airplane overhead, is outside the vertical sector and therefore cannot see the light. An observer at position C is within the vertical sector of the light but outside the luminous range of the light, and therefore cannot see the light.

The COLREGS require that a minimum intensity be maintained at all angles from 5 deg above to 5 deg below the horizontal and that at least 60 percent of the required minimum intensity be maintained from 7.5 deg above to 7.5 deg below the horizontal. In a typical application, a navigation light is required to have a luminous range of 3 NM. That is, it must produce an intensity sufficient to be detected at 3 NM if the observer is within the vertical sector from 5 deg above to 5 deg below the horizontal. In the regions between ± 5 deg and ± 7.5 deg, the luminous range must be at least 2.3 NM (Figure 2).

3.0 TASK 1 - TECHNICAL CHARACTERISTICS OF OFF-THE-SHELF EQUIPMENT

3.1 BACKGROUND

In order to determine how close off-the-shelf unmanned barge lights come to meeting the COLREGS, a number of lights were procured and measurements were made. Those tested were chosen from a list of equipment "accepted" by the Coast Guard for use as navigation lights on unmanned barges. In order for manufacturers to get their light on this list of accepted hardware, they must assert that the light meets the minimum luminous intensity requirement on the horizontal and show measurements to support their assertion. The Coast Guard has not verified these measurements.

The manufacturers of the equipment on this list were contacted, informed of this effort, and an attempt was made to procure their equipment so that all currently accepted configurations could be tested.

3.2 METHOD

A subset of accepted equipment was measured. For each navigation light, one horizontal and several vertical luminous intensity profiles were measured. The horizontal profile was taken on the horizontal plane bisecting the light source. The vertical profiles were taken at several horizontal angles in order to avoid only using a particularly good or bad sampling point. White, green, red, and yellow lenses were tested in various configurations, but red was studied in the most detail because it produces the lowest light output due to its lower transmission coefficient.

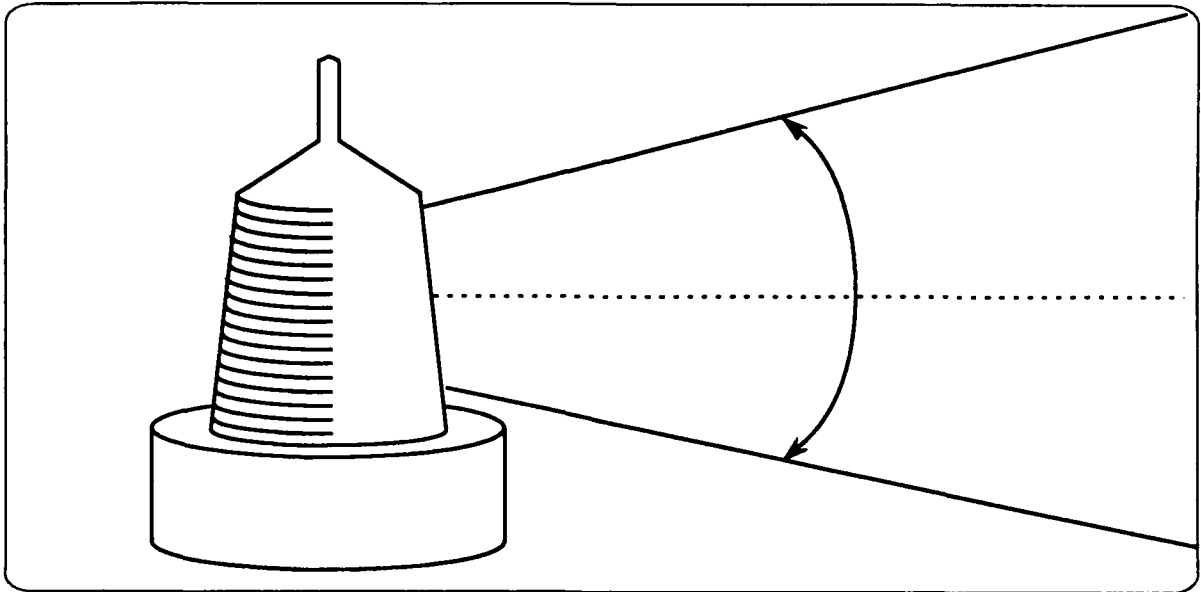

Figure 1a. Vertical Sector

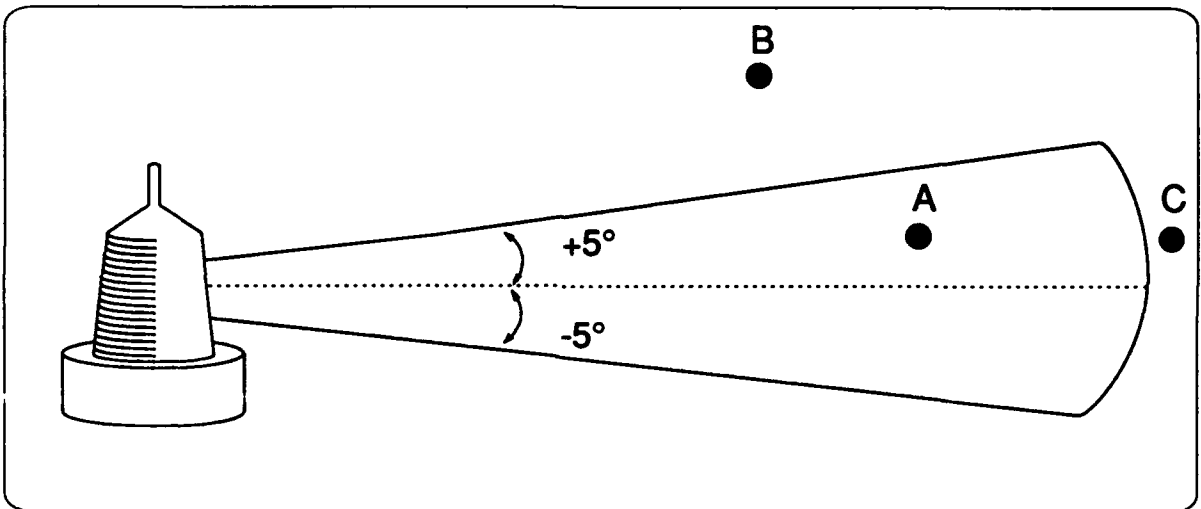

Figure 1b. Vertical Sector of ± 5 Degrees from Horizontal

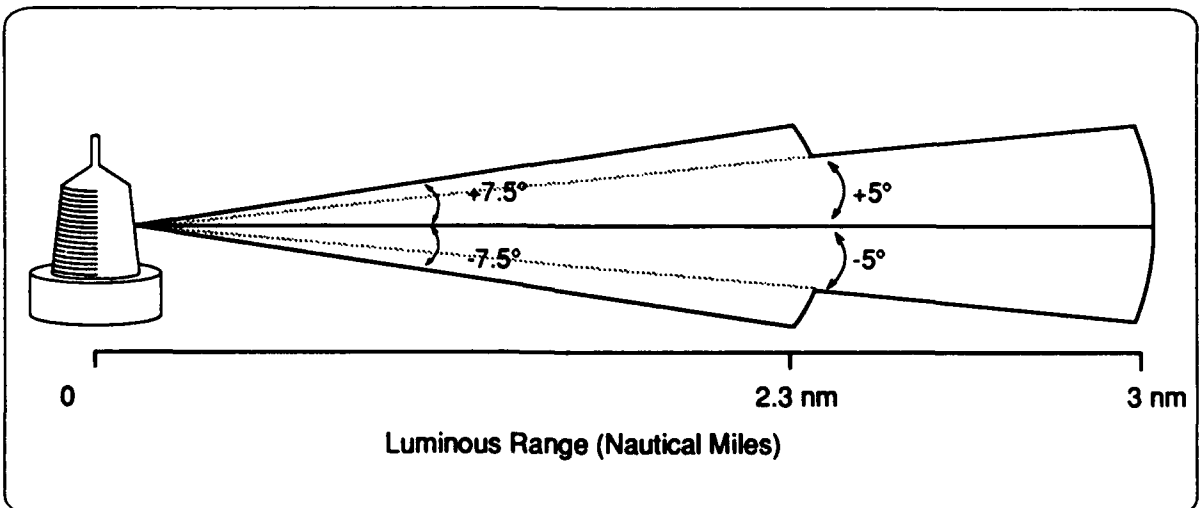

Figure 2. COLREGS Vertical Sector Profile

All measurements were made in the Photometric Laboratory at the Coast Guard Research and Development Center. This laboratory consists of an EG&G radiometer/photometer and a Scientific Atlanta Positioner all operated by a Hewlett Packard 9000, 200 series computer controller. This laboratory uses the zero length photometry method which employs a long focal length mirror to simulate measurements in the far field. The mirror is front surfaced, 36 inches in diameter, and has a focal length of 10 meters. The detector was calibrated in March 1990 by the manufacturer, and is traceable to national standards. This lab is fully devoted to photometric measurements of standard U.S. Coast Guard aids to navigation hardware.

3.3 RESULTS

Examples of the actual measurements and scans are included as Appendix B. Some of the lights tested produced the minimum luminous intensity on the horizontal with a small vertical sector of ± 1.5 deg. Others produced the minimum luminous intensity on the horizontal with no appreciable vertical sector, and still others did not meet the minimum luminous intensity on the horizontal. None of the off-the-shelf equipment tested met the COLREGS specification.

4.0 TASK 2 - OPERATIONAL PERFORMANCE

4.1 BACKGROUND

The objective of this portion of the study was to find a way to relate the measured vertical sectors of barge lights to their operational performance. To do this requires an appreciation of the role of the vertical sector of a navigation light.

The vertical sector of a navigation light serves two purposes. It enables there to be differences in height above the water between the signal light and the observer, and it allows for some misaiming of the light. The light is misaimed if it is not properly mounted on the barge, the barge is not properly trimmed, or the barge is pitching and rolling.

If a source produces light of requisite intensity over a range of vertical angles then the observer and the source do not have to be at the same height in order for the light to be detected. As long as the observer is in the vertical sector and within the luminous range, the light is detectable.

To determine the operational performance of various off-the-shelf lights, we determined the vertical sector distribution required to account for the most extreme height-of-eye differences. The difference between this vertical sector and the vertical sector of a COLREGS or off-the-shelf light provides a way to quantify how much misalignment of the light can be tolerated without reducing detection distance. This procedure

also allows us to compare the performance of off-the-shelf equipment to the COLREGS.

4.2 METHOD

Consider a vessel, approaching a barge, with a lookout on the bridge. An adequate barge light is one which provides enough light in the direction of the lookout to ensure that he can always detect the light as his vessel approaches the barge. Assuming that the lookout is 100 feet above the level of the barge light, and that the barge and barge light are level, the intensity required in the direction of the lookout can be computed. To compute the vertical angle, theta (θ), of the observer with respect to the light (Figure 3a), we use the trigonometric relationship:

$$\theta = \arctan(\text{HOE}/D_h)$$

where HOE is the height of eye difference between the lookout and the barge light, and D_h is the distance between the barge light and the lookout along the horizontal (Figure 3a).

The actual distance that the light must travel to reach the observer, D , can be calculated using:

$$D = D_h / \cos(\theta).$$

To determine the minimum intensity required for detection of light at distance D , we use the equation from the COLREGS:

$$I = 3.43 \times 10^6 \times T \times D^2 \times K^{-D}$$

where I is luminous intensity in candelas, T is the threshold factor 2×10^{-7} lux, D is the distance in nautical miles and K is atmospheric transmissivity of 0.8.

Assuming a lookout at a horizontal distance of 3 NM (18228 ft), the angle between the horizontal and the lookout is:

$$\arctan(100 \text{ ft}/18228 \text{ ft}) = 0.31 \text{ deg.}$$

The actual distance between the observer and light is:

$$18228 \text{ ft}/\cos(0.31 \text{ deg}) = 18228.2 \text{ ft.}$$

The intensity required in order for the lookout to see the light is:

$$I = 3.43 \times 10^6 \times 2 \times 10^{-7} \times 3.0^2 \times 0.8^{(-3.0)} = 12.1 \text{ cd.}$$

This intensity is shown on the inset of Figure 3b as the data point at an angle of 0.31 deg and an intensity of 12.1 cd (PT 1).

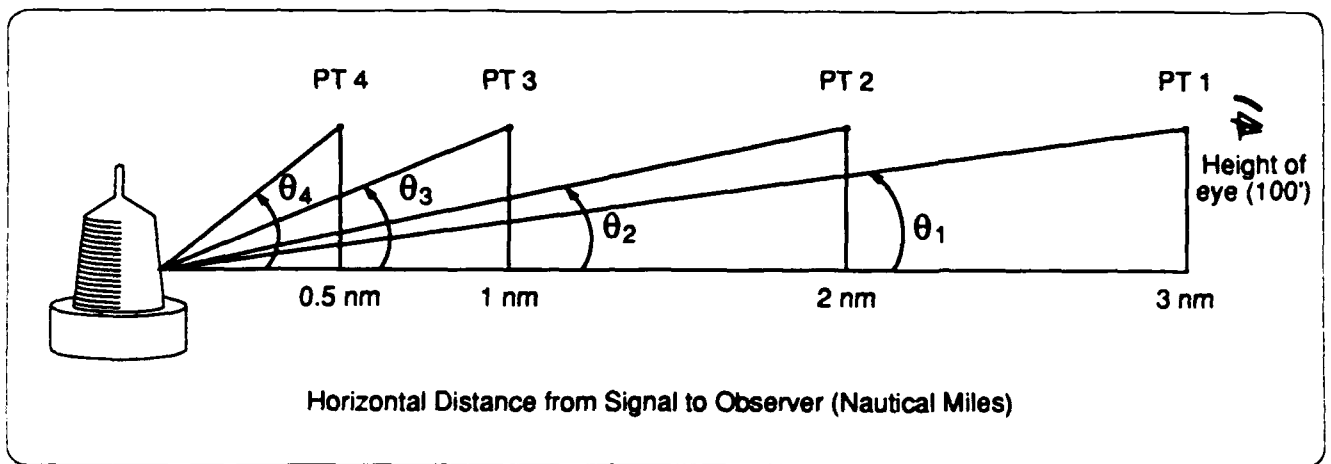

Figure 3a. Triangle Relationship of Vertical Angle, Height of Eye, Horizontal Distances, and Light Path Distance

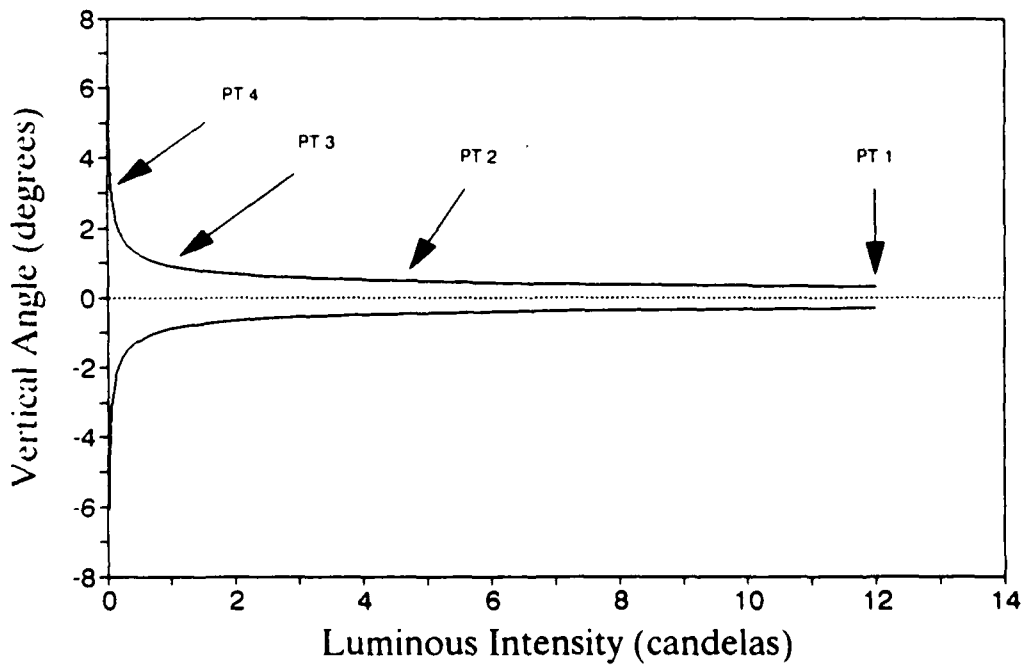

Figure 3b. Luminous Intensity Required For 100 Ft Height of Eye

If the vessel now moves closer to the light to a horizontal distance of 1 NM, we find that the angle is 0.94 deg, the light travels a distance of 6076.8 ft and the required intensity is 0.86 cd. This point is also shown on the inset in Figure 3b (PT 3). If these calculations are performed at a number of horizontal distances, a curve is derived that shows the luminous intensity required to detect the light as the ship gets closer to the light.

4.3 RESULTS

4.3.1 Theoretical Distribution For Height Of Eye Differences

Figure 4 shows the vertical sector light distribution required for a barge light to be detected from a height difference of ± 100 ft.² This is the same distribution as the one shown in figure 3b with the X and Y axes reversed and is referred to as the "minimum distribution." Figure 4 also shows minimum distributions for height differences of ± 50 and ± 200 ft. The actual height of eye difference has an effect on the width of this curve. If the height of eye difference is reduced, the minimum distribution becomes narrower, as shown by the curve labeled 50 ft. If the height of eye difference is increased, the minimum distribution becomes wider, as shown by the curve labeled 200 ft.

By choosing a height of eye difference which is inclusive of all possible situations that could occur on the water, we can represent a worst case scenario. We have assumed that 100 ft is the most extreme height of eye difference that might be encountered. A survey required to confirm this is beyond the scope of this effort.

4.3.2 Analysis Of Aiming Errors

If a light is mismounted on a barge, the barge is out of trim or the barge is pitching and rolling, the light may tend to point toward the sky or toward the water. The vertical sector allows the light to be misaimed at a point above or below the horizontal without affecting detection distance.

The first two aiming errors are controllable and can be minimized. Proper mounting of the light signal on the barge is assumed. This error should be small, and minimizing it is not a technical problem. Loading of the barge to obtain a level trim is a common practice, and in the best interest of the barge operator as level trim equates to less drag and increased fuel efficiency.

² The observer can be either above or below the barge light, and this produces a symmetry in the distribution.

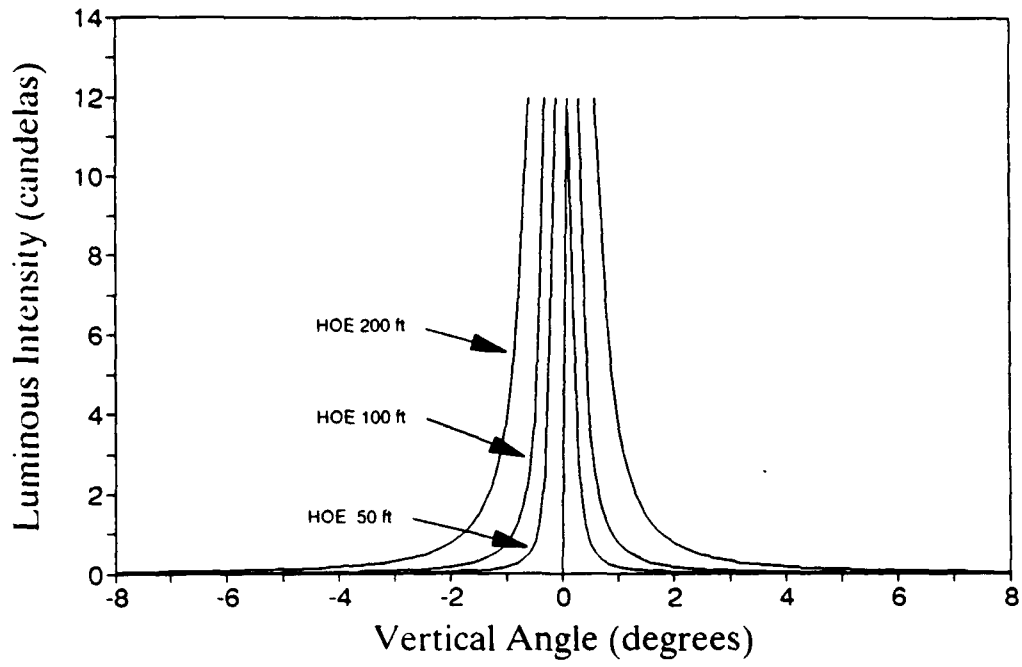

Figure 4. Minimum Distributions For 50, 100, and 200 Ft Height of Eye

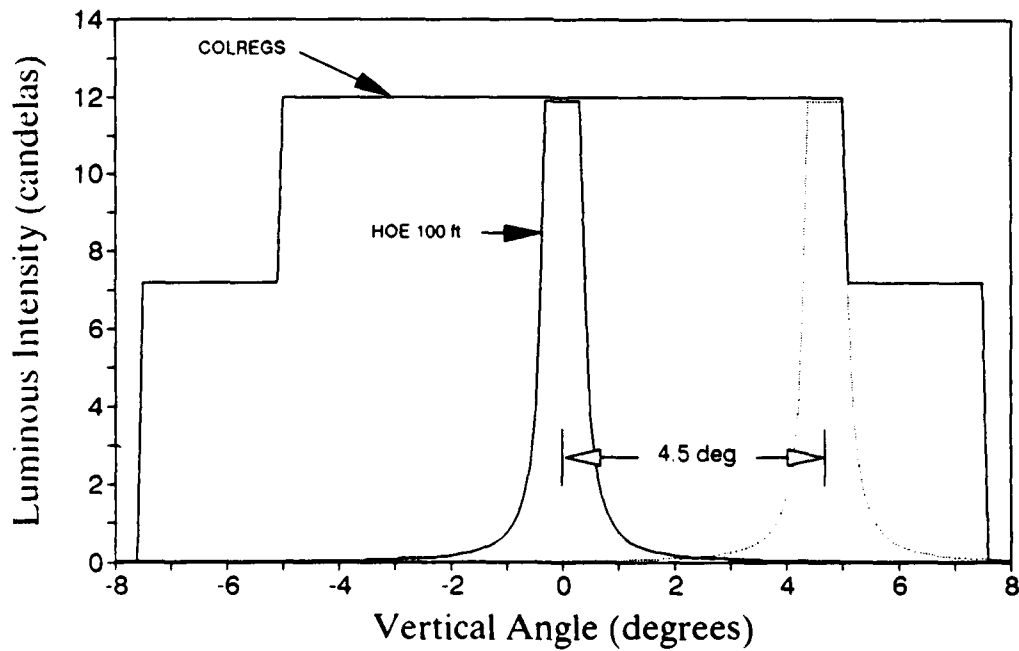

Figure 5. Comparison of COLREGS and Minimum Luminous Intensity Distributions

Pitching and rolling, or the motion of the barge is not controllable, and is only addressed briefly in this effort. Motion tends to decrease the availability of the desired light signal as the luminous intensity distribution varies.³ Since the vertical sector requirements are the same for all types of vessels, except sailing vessels, motion is not an error which is unique to barges.

The larger the vertical sector of a light the more tolerant it is to mounting errors, poor trim, and barge motion.

4.3.3 Margin Of Error Of COLREGS Light

Figure 5 compares the minimum distribution at a height of eye difference of 100 ft to the COLREGS distribution. It is obvious that the COLREGS distribution is much larger than the minimum distribution. The difference between these distributions is the margin of error permitted in the aiming of the light.

Figure 5 also shows how the margin of error is determined for a COLREGS light. The margin of error is found by determining how far the minimum distribution can be moved along the horizontal axis and still fit within the COLREGS distribution. This equates to how much a COLREGS light can be misaimed before it affects its ability to be detected. This figure shows that a COLREGS light has a margin of error of ± 4.5 deg.

4.3.4 Margin Of Error Of Off-The-Shelf Lights

The margin of error for off-the-shelf barge lights is found by determining how far the minimum distribution can be moved along the vertical axis and still fit within the off-the-shelf distribution. Figures 6a and 6b show two of the off-the-shelf red lights that were measured. These two lights produced the best signal, i.e. of the off-the-shelf lights tested they provided the largest margin of error. These signals have up to a ± 1.5 deg margin of error for a height of eye difference of 100 ft. Others met the minimum luminous intensity requirement on the horizontal, but did not have any margin of error. Still other configurations did not even meet the minimum luminous intensity requirements on the horizontal.

5.0 TASK 3 - TRADE-OFFS

5.1 BACKGROUND

The final part of the analysis was to calculate the power needed to produce a luminous intensity distribution that would meet the COLREGS specification, and generate some examples of the

³ Because of barge motion, the light signal may not be visible continuously, but should be visible intermittently. This is what is meant by a decrease in availability.

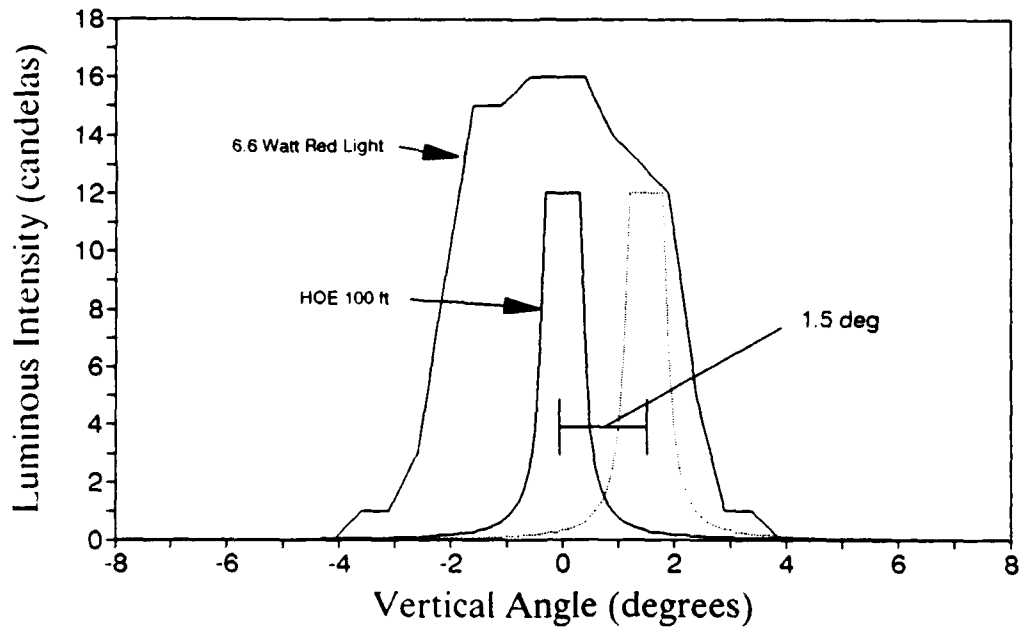

Figure 6a. Comparison of Off-The-Shelf and Minimum Luminous Intensity Distributions

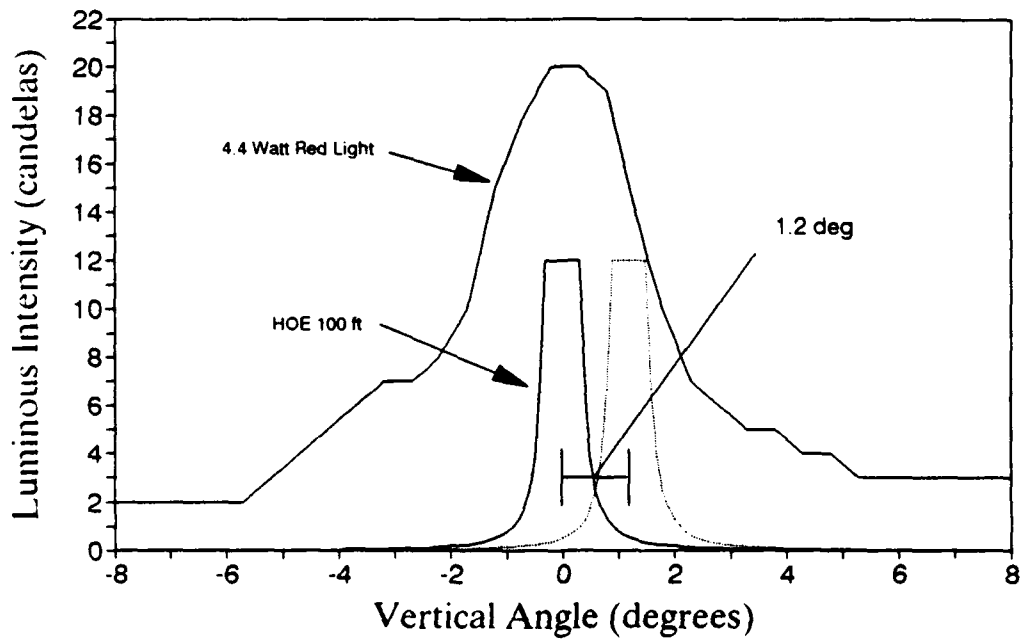

Figure 6b. Comparison of Off-The-Shelf and Minimum Luminous Intensity Distributions

power equipment needed to produce it. This information will enable the Coast Guard to assess the costs incurred by the barge industry if exemptions to the COLREGS are not granted.

5.2 METHOD

The following calculation provides an example of the power required to produce the COLREGS specification using a red light. As stated before, red is used because it provides the greatest challenge because of the low transmission coefficient of red filters. Given that a solution for the red light can be found, the solutions for the other colors will follow. This is because the green filter has a transmission coefficient which is similar to red, and the white (clear) filter has a much higher transmission coefficient. Thus the power required for the green light is comparable to the red light, and much less power is needed to produce the white light distribution. From this calculation, a cost estimate was made by providing examples of the equipment which could produce the power.

5.3 RESULTS

If one were to design a red light that exactly produced the COLREGS specification for a 3 NM light, 5.3 lumens would be required. To actually duplicate the COLREGS light distribution would require a very specialized optical system that would only emit light into a window which is 15 deg vertical by 112.5 deg horizontal. A more realistic system is similar to that of off-the-shelf equipment that emits light at all horizontal angles and has a smoothly shaped vertical profile.

Approximately 17 lumens of red light would be required to produce the COLREGS vertical profile emitting light into a spherical sector 15 deg wide in the vertical and 360 deg in the horizontal. Approximately two thirds of the light is baffled to produce the horizontal cutoffs, and this power is wasted by design. There is potential to recover some of this light, but it is not easy, and will not be included in this calculation.

Assuming that white light is produced by the source and filtered to the desired color, and using a transmission coefficient of 0.24 for a red filter, 71 lumens of white light would be needed from the source to produce 17 lumens of red light outside the filter.

The COLREGS specified shape for the vertical sector is not easy to produce. A Fresnel lens is designed to concentrate the light into a narrow vertical distribution. In practice it produces a vertical luminous intensity distribution which has a shape which resembles a bell. It appears that a particular combination of lamp and lens could be found to produce the COLREGS distribution, without wasting a lot of power. As an example, a Gaussian distribution which would envelope the COLREGS distribution would require 120 lumens to produce (Figure 7).

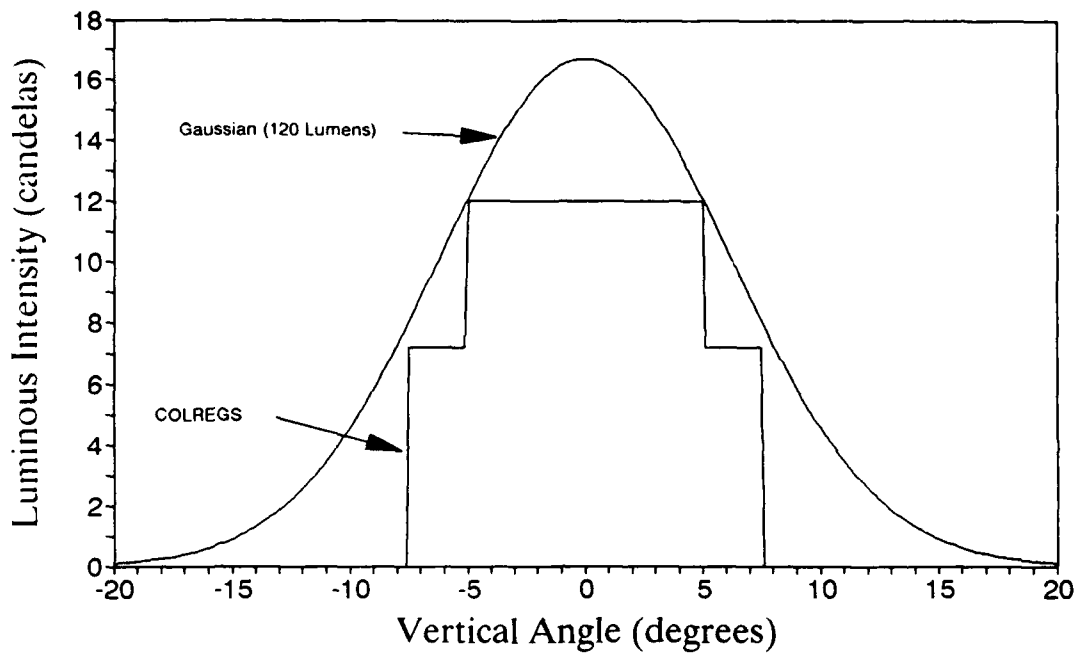

Figure 7. Comparison of Gaussian and COLREGS Luminous Intensity Distributions

This would be a reasonable estimate for the amount of white light that would need to be produced at the source.

Current tungsten filament technology produces approximately 10 lumens per watt⁴, so we would need 12 watts of power, or 1 ampere of current at 12 Volts dc. The light would be operated for approximately 14 hours each day.

5.3.1 Battery Powered Lights

The specific circumstances of the operations of the barge will dictate the best power system. Logistics for replenishing the power system is a major concern. As an example, the Coast Guard currently uses 12 Volt rechargeable batteries that are rated at 1 ampere current drain for 100 hours. The size of these batteries is about 13x7x9 inches, and they weigh about 57 pounds. They cost about \$100.00 each. If deep discharged, each battery would run one sidelight 5 to 7 days at 14 hours per day. As a practical matter the batteries would probably be recharged more often than this in order to extend battery life and insure signal availability. For extended operation, multiple batteries would be needed. Again, a strategy would have to be developed taking into account the logistics of charging the batteries and the operations schedule of the barges.

5.3.2 Solar Powered Lights

As another example, the concept of having a fairly self-sufficient power system is desirable. Solar power may not be cost effective in all areas and in all situations, but in those areas where solar energy is plentiful and extended operations are needed, it could be preferable. The combination of solar photovoltaic panels with rechargeable batteries could power the signal lights indefinitely. The size of the panel needed would depend on the amount of daylight available, which depends on the latitude, climate, season, etc.

For a 3 NM red sidelight, and assuming a discharge of 14 Ampere-hours per day, the battery would require approximately 18 Ampere-hours per day to replace the charge. Given about 4 hours of peak sunlight per day average, a 60 watt panel which would produce 4-5 Amperes would be needed. This would also be a shallow discharge for the battery, which would prolong its life.⁵

The cost of solar panels is about \$10.00 per watt installed. A 60 watt panel would be needed on each of the sidelights, while a 15 watt panel could be used on the stern light. For this example, two 100 Ampere-hour batteries would be used on each of the sidelights, and one on the stern light. The cost for this

⁴ Those tested ranged from 7 to 13 lumens per watt.

⁵ Daily cycling of the battery in this fashion would only discharge the battery 14 Ampere-Hours or about 14% of its rated capacity. This would be considered a shallow discharge.

system to power red and green sidelights and a white stern light would be about \$1800.00. This is the cost for the power system only. It does not include the signals, or any mounting hardware, etc.

6.0 CONCLUSIONS

Navigation lights presently in use on unmanned barges do not meet the COLREGS specification for vertical sector. Some accommodate height of eye differences and provide a small margin of error. Some meet the requirements of the Inland Rules; some do not.

Unmanned barge lights that only provide the minimum luminous intensity on the horizontal, as per the Inland Rules, do not account for height of eye differences between the signal and the observer.

In order to account for height of eye differences, some vertical sector is needed. In addition to accounting for height of eye differences, the vertical sector must account for aiming errors. The appropriate vertical sector depends on the magnitude of the aiming errors (mismounting, barge trim, and barge motion).

A small margin of error could provide for mounting errors and trim. Barge motion might be accounted for by vertical sector, but a safety margin large enough to include all pitching and rolling might be unreasonable.

The need to account for height of eye differences and provide a margin of error suggests that the Inland Rules should require some vertical sector, not just the minimum luminous intensity on the horizontal.

How large the vertical sector should be was not determined by this effort. Specific knowledge of height of eye differences and aiming errors is required to make that determination. The COLREGS specification currently exists as one attempt to quantify this issue.

The COLREGS specification could be met with equipment very similar to the off-the-shelf equipment, but it may not be cost effective given the small population of vessels with this problem.

The problem with barge lights meeting the vertical sector requirements of the COLREGS is the lack of readily available power. Unmanned barges are held to the same vertical sector standards as ships and other self propelled vessels. Self propelled vessels do not have a problem meeting vertical sector requirements, simply because they have a readily available supply of power.

The amount of power needed to meet all of the technical requirements of the COLREGS is not large, but is not trivial to produce with batteries.

7.0 RECOMMENDATIONS

The Coast Guard should study this matter further, in order to fully determine the effect of vertical sector on navigation safety. Accident data, industry comment, and consultations with the Navigation Safety and Towing Safety Advisory Councils should be included in this survey.

If it is determined that a new vertical sector requirement is warranted, it should be based on the following factors:

A survey of existing vessels to define a reasonable height of eye difference.

The typical trim of barges, light mounting errors, and barge motion, to determine an acceptable margin of error.

[B L A N K]

APPENDIX A

**Vertical Sector Requirements for
Unmanned Barges Operating
in COLREG Waters**

(C-2)

**Rules of the Road Advisory Council
Seattle, Washington
1-3 November 1989**

[B L A N K]

**Vertical Sector Light Requirement for Unmanned Barges
Operating in International Waters**

NAVRULES reference:

- International Rules: Annex I, Section 10
- Inland Rules: Annex I, Section 84.19(c)
- International Rule 24 (h)

Issue: Most U.S. unmanned barges operating in International waters do not meet the vertical sector lighting requirements contained in Annex I, Section 10. Unmanned barges operating in Inland waters are excluded from the vertical sector requirement, but must meet the minimum intensity on the horizontal.

NAVRULES requirement (International):

- minimum intensity at all angles from 5 degrees above to 5 degrees below the horizontal.
- at least 60% of minimum intensity from 7.5 degrees above to 7.5 degrees below the horizontal.

Current status: COMDTINST 16672.3A dated 10 May 1989 allows battery powered navigation lights used on unmanned barges, not equipped with machinery for the generation of electricity, to meet as closely as practicable the vertical sector requirements of the 72 COLREGS. This COMDTINST relies on the provisions of Rule 24(h) and will be valid indefinitely until the Coast Guard completes its research and development studies and other solutions or recommendations are provided.

Background:

- Prior to the 72 COLREGS there were no technical requirements for vertical sectors of navigation lights.
- The 72 COLREG requirements became effective 15 July 1977.
- Rule 38 exemptions to the 72 COLREGS expired 15 July 1981 for the intensity requirements of Rule 22.
- Since 1 February 1978, the Coast Guard has not tested for compliance with the vertical sector requirements of navigation lights on unmanned barges using battery powered lights if the barge was not equipped with machinery for the generation of electricity.

● The basis for not testing for compliance has rested in Rule 24(h): "Where from any sufficient cause it is impractical for a vessel or object being towed to exhibit the lights.... prescribed...., all possible measures shall be taken.... etc." Battery powered lights capable of meeting the requirements are so burdensome and expensive they are prohibitive and impractical; in the opinion of the Coast Guard this was "sufficient cause" as the term is used in Rule 24(h).

● A Request for Comments on this subject was published in the Federal Register on 6 July 1984. The Coast Guard received 13 replies; all but one supported an exemption or alternative solution to meeting the vertical sector requirements on unmanned barges.

● The 72 COLREGS, including the Annexes, are a treaty; changes are enacted via an established procedure in accordance with Article VI of the Convention on the International Regulations for Preventing Collisions at Sea, 1972.

● On 7 February 1986 the Coast Guard submitted a Note by the Government of the United States concerning Vertical sectors of electric lights on unmanned barges to the 32nd session of the International Maritime Organization's Subcommittee on the Safety of Navigation. The note requested an acceptance of the Coast Guard interpretation of Rule 24(h) to exempt unmanned seagoing barges being towed from complying with the vertical sector requirements when it is impractical to do so. The note also requested application to unmanned seagoing barges being pushed ahead or towed alongside.

● IMO responded that there was no reason to amend the 72 COLREGS and was of the opinion that the U.S. could overcome the problem by either technical provisions or applying Rule 1(e).

● Technical solutions still appear impractical at this time (RORAC meeting November 1989).

● There currently are no "blanket exemptions" allowed under the U.S. process (Regulations) granting alternative compliance as allowed under Rule 1(e) of the 72 COLREGS. Owners, builders, operators, or agents of a vessel must submit an application for a Certificate of Alternative Compliance.

● By resolution, the RORAC and Towing Safety Advisory Committee (TSAC) recommended the Coast Guard extend the relaxed requirements in COMDTINST 16672.3. They also favor adding language which will include unmanned barges not normally operating generators underway.

● This issue was discussed and considered at the RORAC working group meeting held in February 1989 in New Orleans.

● On 10 May 1989 the Coast Guard issued Commandant Instruction 16672.3A, effectively indefinitely extending the relaxed requirements allowed under Rule 24(h) of the 72 COLREGS thereby permitting battery powered navigation lights to be used on unmanned barges. For all practical purposes, it serves as a de facto Rule 1 (e) determination.

● The Coast Guard has initiated a research and development study to (a) investigate off-the-shelf battery powered navigation lights to measure their technical characteristics; (b) design and test a low cost battery powered light that meets the minimum requirements; and (c) conduct a series of experiments to determine the reduction in operational performance if the current intensity requirements are reduced. The status of that effort will be reported on separately in committee.

● For purposes of this committee, the Coast Guard wishes to develop a framework to determine "the closest possible compliance" with the Rules. The Coast Guard desires to evaluate the safety of navigation implications from the research and development effort such that a reasonable policy can be achieved.

● The results of this Committee meeting (and future work as necessary) will be presented to the next meeting of the RORAC to be scheduled May 1990. Additional recommendations may be appropriate at that time.

Suggested Questions & Framework
(to be further developed by the committee)

Chairman's note: many of these questions have been answered or pending action based on R and D effort. Recommend hold in abeyance pending outcome of tests. May desire to outline strategy based on predicted outcome of report from R and D Center representative.

- Build upon July 1984 Federal Register Request for comments.
 - Number of unmanned barges operating in COLREG waters.
 - Number of unmanned barges operating in COLREG waters which do not normally operate generators when underway.
 - Number of unmanned barges which do not meet the requirements of Annex I.
 - What are the minimum vertical sectors currently met by approved barge lights? What does this mean on the water? (Roll & pitch, etc.)
 - What are the problems encountered by other vessels in sighting unmanned barges using currently approved lights?
- What are the minimum and maximum sizes of barge (e.g. LOA, beam, draft, etc.) and the respective heights above the waterline of sidelights/sternlight?
- What are their cargoes?
- What are the durations of voyages? How much time between light "recharges" or servicing.
- What are other countries doing? What is the size of their unmanned barge fleet? Etc.
- Do marine underwriters consider this issue problematic?
- How many Certificates of Alternative Compliance have been requested? Approved?
- What is the accident history of unmanned barges, particularly with respect to sidelights and stern lights?
- Should relaxation of vertical sector requirements be extended to towing alongside or pushing ahead? Why?
- What equipment, other than generators, is available to meet the requirement? What is its size, cost, etc?
- Develop "cost of equipment" vs. "range of light" tables.

References available to Committee on
Vertical Sector Requirements for
Unmanned Barges Operating in International Waters

1. RORAC resolution from 18 - 20 October 1988 meeting.
2. Marine Navigation Lights - UL 1104
3. COMDTINST 16672.3 dated 10 January 1986; International Regulations for Preventing Collisions at Sea, 1972 (72 COLREGS); Lights for unmanned barges.
4. Commandant (G-MVI-1/14) letter 16672 dated 8 August 1988 amending COMDTINST 16672.3 dated 10 January 1986 to include unmanned barges that do not have machinery onboard intended for operation when the barge is underway.
5. Excerpts from Chapter 18, paragraph L. Navigation Equipment, Marine Safety Manual, COMDTINST M16000.7.
6. Commandant (G-MTH-2) list of approved barge lights: 12/87.
7. 6 July Federal Register Request for Comments and replies.
8. Note by the Government of the United States to IMO's Subcommittee on Safety of Navigation dated 7 February 1986 and the Working Group's reply.
9. Letters from Underwriter's Laboratories, Inc. (7 June 1988); Perko, Inc. (20 September 1988); Automatic Power, Inc. (17 June 1988)
10. Crowley Maritime Corporation letter dated 14 September 1988 with enclosure "Graphic sketches depicting greater stability of typical barge."
11. Commandant (G-MMI-3/24) letter 16732 dated 22 September 1988 to Mr. Bedient, Crowley Maritime concerning accident statistics.
12. USCG Investigation: M/V CI MAR collision with freight barge CMS 751 in the tow of the M/V John M. Selvick in Lake Michigan June 26, 1985.
13. USCG Investigation:
14. Chief, Office of Navigation Safety and Waterway Services Memorandum dated 30 March 1989 to Chief, Office of Engineering and Development. Subject: REQUEST FOR R&D SUPPORT.
15. COMDTINST 16672.3A dated 10 May 1989; International Regulations for Preventing Collisions at Sea, 1972 (72 COLREGS); Lights for unmanned barges.
16. Unmanned Barges - Ocean "count" from Lester C. Bedient

[B L A N K]

APPENDIX B

SAMPLE DATA FROM OFF-THE-SHELF EQUIPMENT

[B L A N K]

HORIZONTAL INTENSITIES

LANTERN = 120mm BARGE LANTERN, RED LENS (112.5)
 LAMP = TIDELANDS 6.2VDC, .70A
 SOURCE TO DETECTOR DISTANCE = 10.68 METERS OR 35.04 FEET
 DATE = 5 Apr 1990
 OPERATOR IS MIKE FISHER

DEGREE	READING (ft cd)	INTENSITY (cd)	DEGREE	READING (ft cd)	INTENSITY (cd)
-90.00	0.0000	0	0.00	.0160	20
-85.00	.0001	0	5.00	.0158	19
-80.00	.0001	0	10.00	.0160	20
-75.00	.0001	0	15.00	.0161	20
-70.00	.0002	0	20.00	.0159	20
-65.00	.0003	0	25.00	.0160	20
-60.00	.0006	1	30.00	.0156	19
-55.00	.0067	8	35.00	.0159	20
-50.00	.0154	19	40.00	.0151	19
-45.00	.0154	19	45.00	.0154	19
-40.00	.0161	20	50.00	.0154	19
-35.00	.0165	20	55.00	.0010	1
-30.00	.0158	19	60.00	.0005	1
-25.00	.0160	20	65.00	.0003	0
-20.00	.0158	19	70.00	.0002	0
-15.00	.0160	20	75.00	.0001	0
-10.00	.0160	20	80.00	.0001	0
-5.00	.0160	20	85.00	0.0000	0
0.00	.0160	20	90.00	0.0000	0

POLAR PLOT OF
HORIZONTAL INTENSITIES
120mm BARGE LANTERN, RED LENS (112.5)
TIDELANDS 6.2VDC, .70A

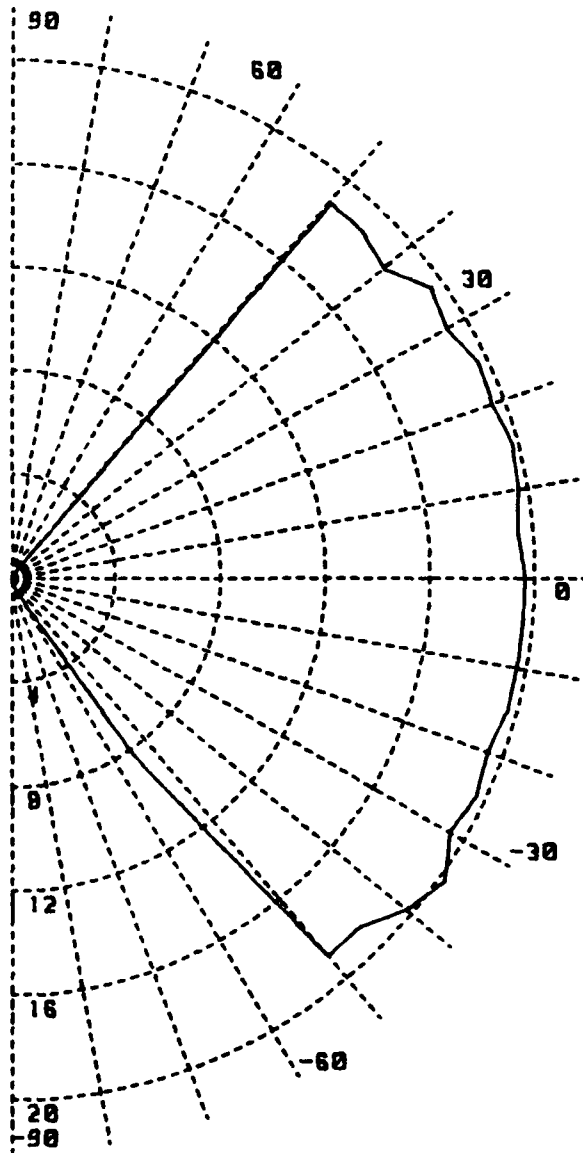

VERTICAL INTENSITIES
 MEASURED THROUGH HORIZONTAL DEGREE, 0

LANTERN = 120mm BARGE LANTERN, RED LENS (112.5)
 LAMP = TIDELANDS 6.2VDC, .70A
 SOURCE TO DETECTOR DISTANCE = 10.68 METERS OR 35.04 FEET
 DATE = 5 Apr 1990
 OPERATOR IS MIKE FISHER

DEGREE	READING (ft cd)	INTENSITY (cd)	DEGREE	READING (ft cd)	INTENSITY (cd)
-8.00	.0015	2	0.00	.0164	20
-7.50	.0013	2	.50	.0164	20
-7.00	.0014	2	1.00	.0151	19
-6.50	.0015	2	1.50	.0116	14
-6.00	.0017	2	2.00	.0083	10
-5.50	.0020	2	2.50	.0059	7
-5.00	.0025	3	3.00	.0050	6
-4.50	.0035	4	3.50	.0042	5
-4.00	.0044	5	4.00	.0037	5
-3.50	.0052	6	4.50	.0032	4
-3.00	.0055	7	5.00	.0029	4
-2.50	.0059	7	5.50	.0026	3
-2.00	.0065	8	6.00	.0024	3
-1.50	.0085	10	6.50	.0022	3
-1.00	.0119	15	7.00	.0022	3
-.50	.0148	18	7.50	.0020	3
0.00	.0164	20	8.00	.0020	3

PLOT OF
VERTICAL INTENSITIES
MEASURED AT HORIZONTAL DEG. 0
120mm BARGE LANTERN, RED LENS (112.5)
TIDELANDS 6.2VDC, .70A

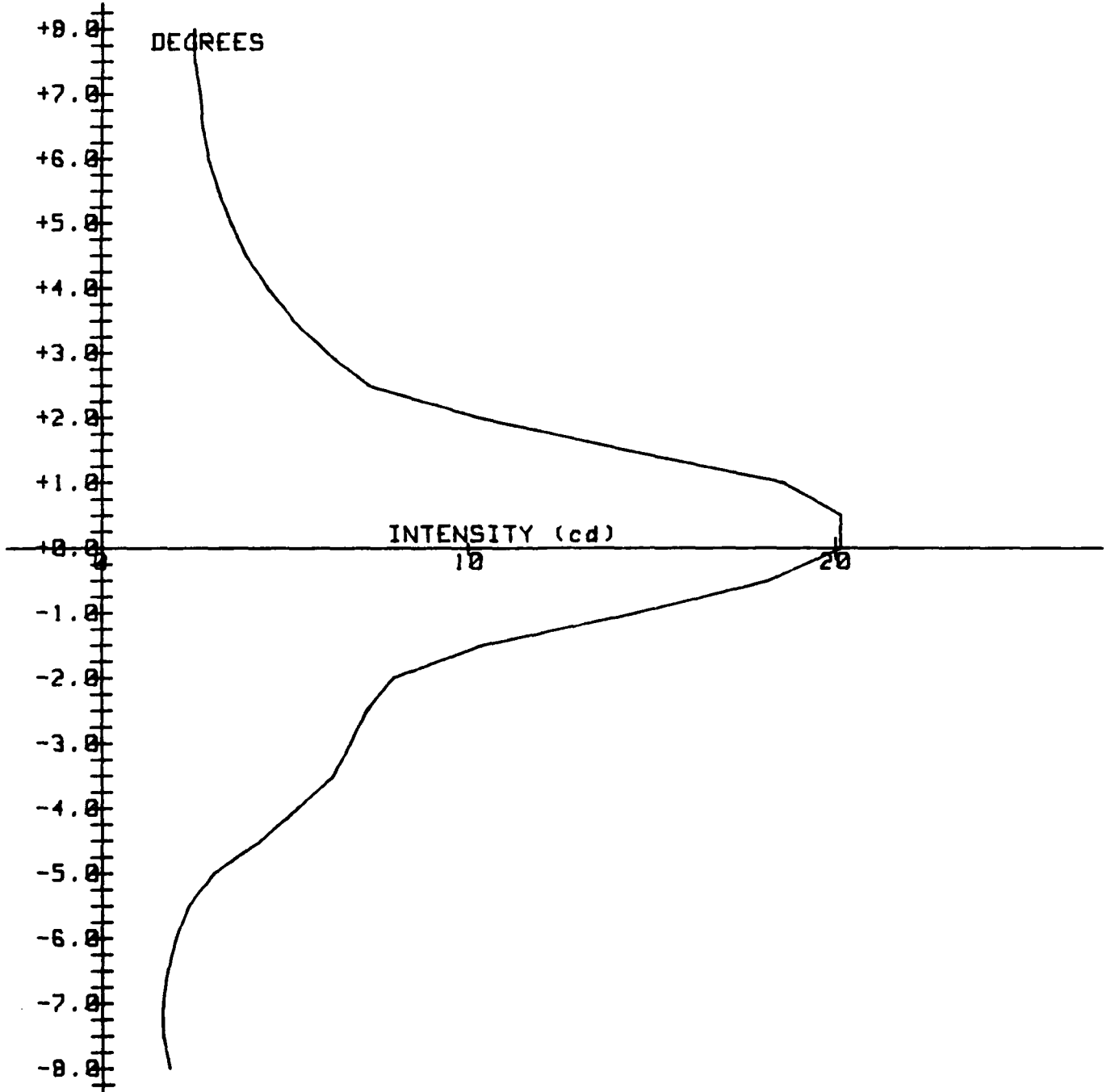

VERTICAL INTENSITIES

MEASURED THROUGH HORIZONTAL DEGREE, 40

LANTERN = 120mm BARGE LANTERN, RED LENS (112.5)

LAMP = TIDELANDS 6.2VDC, .70A

SOURCE TO DETECTOR DISTANCE = 10.68 METERS OR 35.04 FEET

DATE = 5 Apr 1990

OPERATOR IS MIKE FISHER

DEGREE	READING (ft cd)	INTENSITY (cd)	DEGREE	READING (ft cd)	INTENSITY (cd)
-8.00	.0013	2	0.00	.0153	19
-7.50	.0012	2	.50	.0158	19
-7.00	.0013	2	1.00	.0147	18
-6.50	.0013	2	1.50	.0119	15
-6.00	.0015	2	2.00	.0095	12
-5.50	.0018	2	2.50	.0068	8
-5.00	.0024	3	3.00	.0055	7
-4.50	.0033	4	3.50	.0046	6
-4.00	.0041	5	4.00	.0040	5
-3.50	.0048	6	4.50	.0035	4
-3.00	.0053	6	5.00	.0030	4
-2.50	.0057	7	5.50	.0026	3
-2.00	.0063	8	6.00	.0024	3
-1.50	.0074	9	6.50	.0022	3
-1.00	.0103	13	7.00	.0020	3
-.50	.0128	16	7.50	.0020	3
0.00	.0153	19	8.00	.0019	2

PLOT OF
VERTICAL INTENSITIES
MEASURED AT HORIZONTAL DEG. 40
120mm BARGE LANTERN, RED LENS (112.5)
TIDELANDS 6.2VDC, .70A

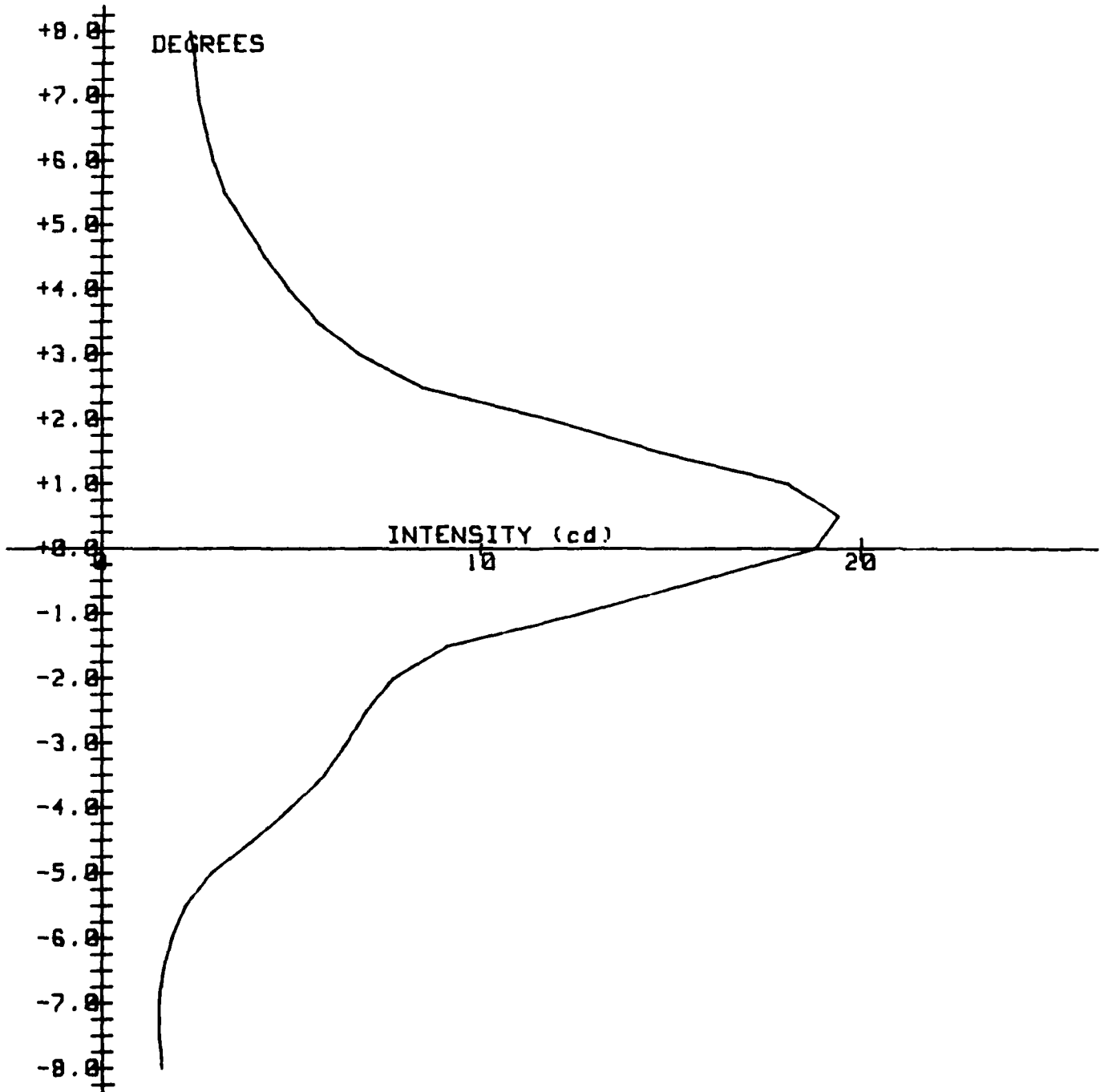

HORIZONTAL INTENSITIES

LANTERN = 155mm BARGE LANTERN, BARGE RED LENS (360)
 LAMP = PHILLIPS 12.0VDC, .55A
 SOURCE TO DETECTOR DISTANCE = 10.68 METERS OR 35.04 FEET
 DATE = 4 Apr 1990
 OPERATOR IS MIKE FISHER

DEGREE	READING (ft cd)	INTENSITY (cd)	DEGREE	READING (ft cd)	INTENSITY (cd)
-180.00	.0111	14	0.00	.0137	17
-175.00	.0112	14	5.00	.0136	17
-170.00	.0117	14	10.00	.0137	17
-165.00	.0122	15	15.00	.0142	17
-160.00	.0132	16	20.00	.0134	16
-155.00	.0129	16	25.00	.0137	17
-150.00	.0133	16	30.00	.0135	17
-145.00	.0132	16	35.00	.0135	17
-140.00	.0136	17	40.00	.0132	16
-135.00	.0134	16	45.00	.0133	16
-130.00	.0135	17	50.00	.0134	16
-125.00	.0135	17	55.00	.0138	17
-120.00	.0134	16	60.00	.0134	16
-115.00	.0136	17	65.00	.0130	16
-110.00	.0131	16	70.00	.0128	16
-105.00	.0136	17	75.00	.0131	16
-100.00	.0134	16	80.00	.0127	16
-95.00	.0136	17	85.00	.0125	15
-90.00	.0138	17	90.00	.0122	15
-85.00	.0140	17	95.00	.0130	16
-80.00	.0141	17	100.00	.0123	15
-75.00	.0137	17	105.00	.0121	15
-70.00	.0137	17	110.00	.0122	15
-65.00	.0136	17	115.00	.0111	14
-60.00	.0135	17	120.00	.0113	14
-55.00	.0133	16	125.00	.0119	15
-50.00	.0131	16	130.00	.0126	15
-45.00	.0137	17	135.00	.0122	15
-40.00	.0142	17	140.00	.0120	15
-35.00	.0142	17	145.00	.0108	13
-30.00	.0140	17	150.00	.0105	13
-25.00	.0146	18	155.00	.0117	14
-20.00	.0138	17	160.00	.0108	13
-15.00	.0140	17	165.00	.0101	12
-10.00	.0140	17	170.00	.0101	12
-5.00	.0134	16	175.00	.0107	13
0.00	.0137	17	180.00	.0109	13

POLAR PLOT OF
HORIZONTAL INTENSITIES
155mm BARGE LANTERN, BARGE RED LENS (360)
PHILLIPS 12.0VDC, .55A

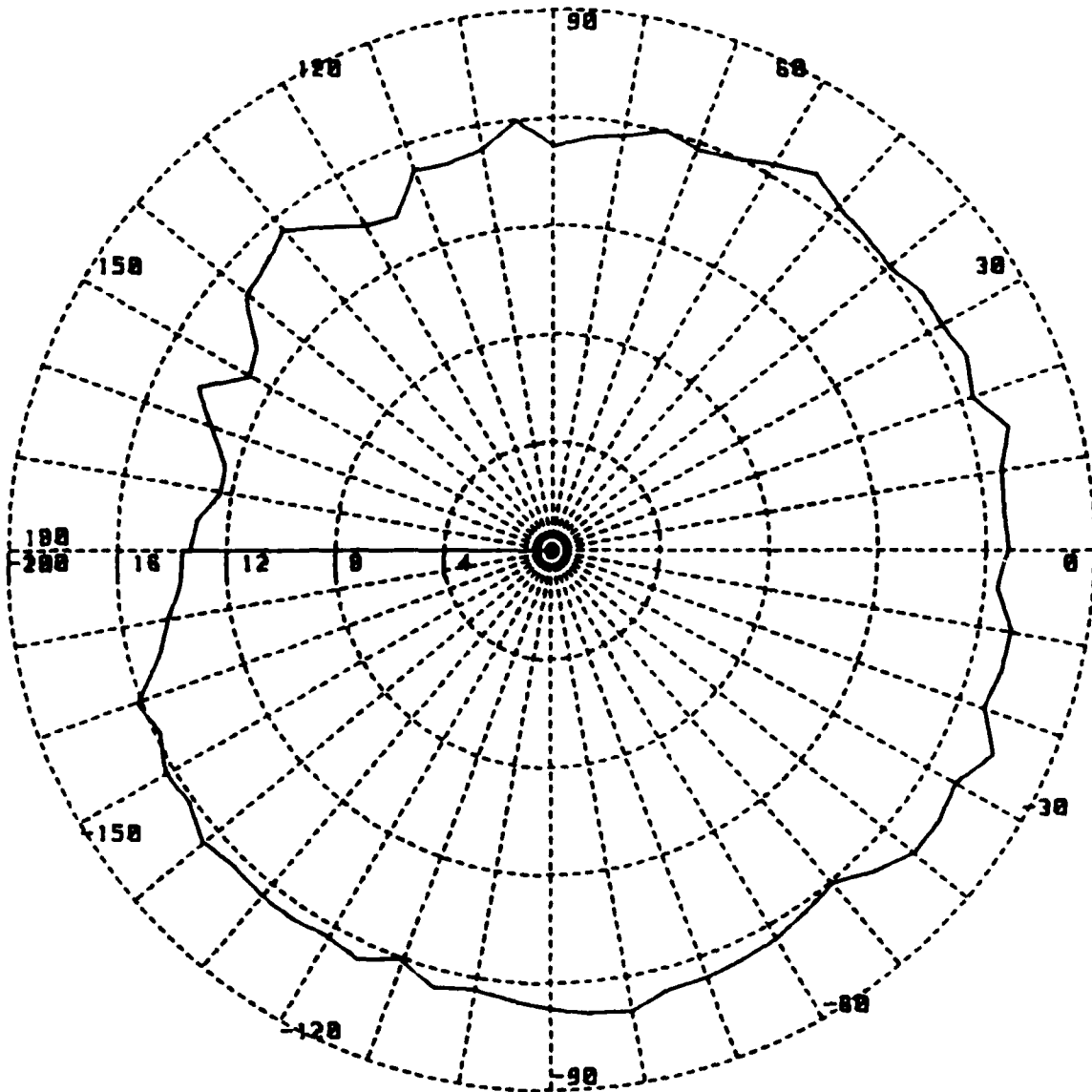

VERTICAL INTENSITIES
 MEASURED THROUGH HORIZONTAL DEGREE, 0

LANTERN = 155mm BARGE LANTERN, BARGE RED LENS (360)
 LAMP = PHILLIPS 12.0VDC, .55A
 SOURCE TO DETECTOR DISTANCE = 10.68 METERS OR 35.04 FEET
 DATE = 4 Apr 1990
 OPERATOR IS MIKE FISHER

DEGREE	READING (ft cd)	INTENSITY (cd)	DEGREE	READING (ft cd)	INTENSITY (cd)
-8.00	.0001	0	0.00	.0133	16
-7.50	.0002	0	.50	.0130	16
-7.00	.0002	0	1.00	.0118	14
-6.50	.0002	0	1.50	.0102	13
-6.00	.0002	0	2.00	.0095	12
-5.50	.0002	0	2.50	.0043	5
-5.00	.0002	0	3.00	.0010	1
-4.50	.0003	0	3.50	.0006	1
-4.00	.0003	0	4.00	.0003	0
-3.50	.0005	1	4.50	.0003	0
-3.00	.0012	1	5.00	.0004	0
-2.50	.0028	3	5.50	.0004	1
-2.00	.0076	9	6.00	.0005	1
-1.50	.0119	15	6.50	.0005	1
-1.00	.0120	15	7.00	.0005	1
-.50	.0127	16	7.50	.0004	1
0.00	.0133	16	8.00	.0004	0

PLOT OF
VERTICAL INTENSITIES
MEASURED AT HORIZONTAL DEG. 0
155mm BARGE LANTERN, BARGE RED LENS (360)
PHILLIPS 12.0VDC, .55A

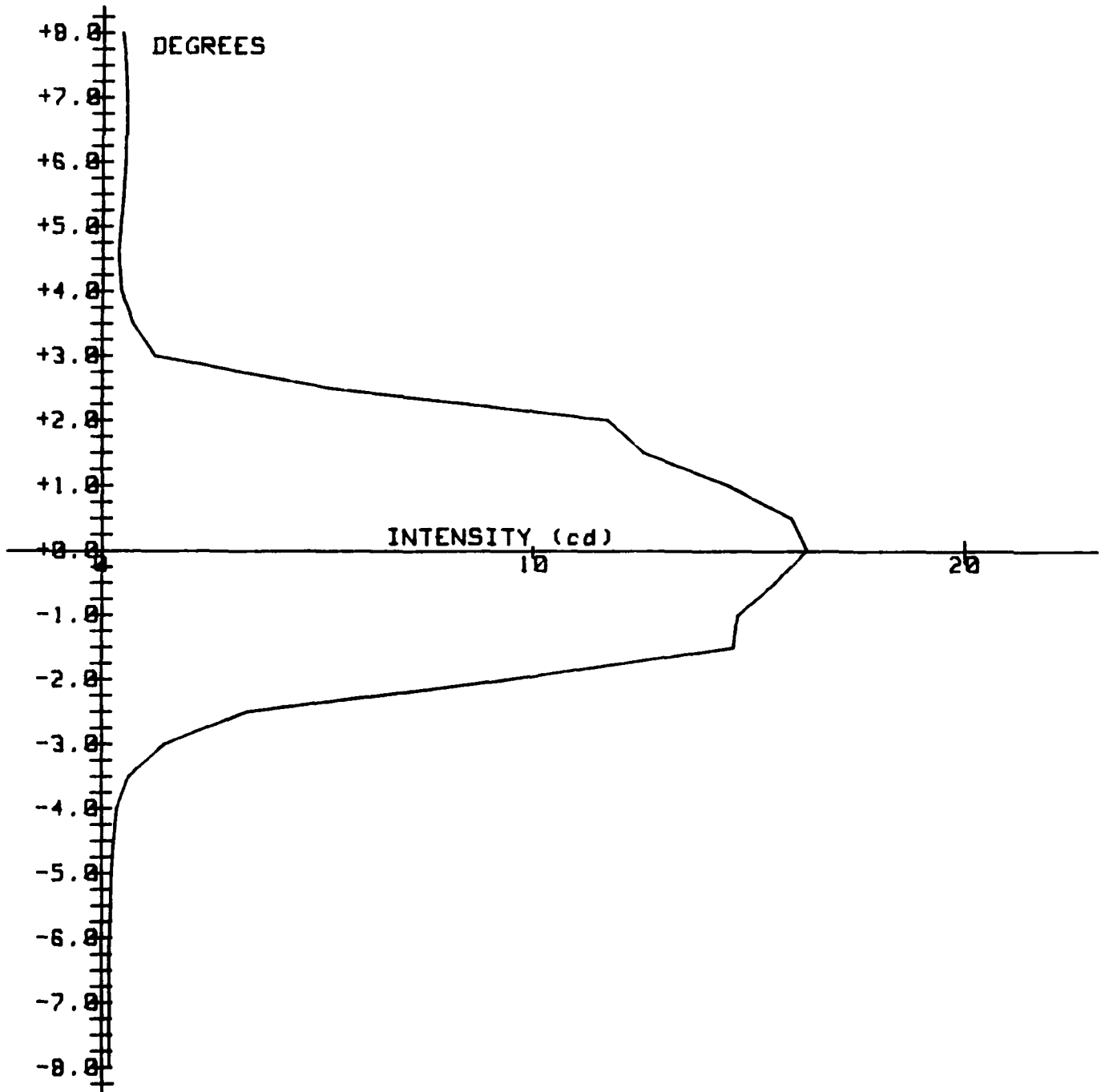

VERTICAL INTENSITIES
 MEASURED THROUGH HORIZONTAL DEGREE, 170

LANTERN = 155mm BARGE LANTERN, BARGE RED LENS (360)
 LAMP = PHILLIPS 12.0VDC, .55A
 SOURCE TO DETECTOR DISTANCE = 10.68 METERS OR 35.04 FEET
 DATE = 4 Apr 1990
 OPERATOR IS MIKE FISHER

DEGREE	READING (ft cd)	INTENSITY (cd)	DEGREE	READING (ft cd)	INTENSITY (cd)
-8.00	.0001	0	0.00	.0101	12
-7.50	.0001	0	.50	.0112	14
-7.00	.0002	0	1.00	.0120	15
-6.50	.0002	0	1.50	.0115	14
-6.00	.0002	0	2.00	.0098	12
-5.50	.0002	0	2.50	.0078	10
-5.00	.0002	0	3.00	.0066	8
-4.50	.0002	0	3.50	.0017	2
-4.00	.0002	0	4.00	.0006	:
-3.50	.0003	0	4.50	.0004	0
-3.00	.0004	0	5.00	.0004	1
-2.50	.0005	1	5.50	.0005	1
-2.00	.0010	1	6.00	.0006	1
-1.50	.0036	4	6.50	.0006	1
-1.00	.0087	11	7.00	.0005	1
-.50	.0105	13	7.50	.0005	1
0.00	.0101	12	8.00	.0004	0

PLOT OF
VERTICAL INTENSITIES
MEASURED AT HORIZONTAL DEG. 170
155mm BARGE LANTERN, BARGE RED LENS (360)
PHILLIPS 12.0VDC, .55A

