

AD-A246 318



①

Communications Research Centre

**AN ADAPTIVE, PACKET-SWITCHED HF DATA TERMINAL
-FUNCTIONAL OVERVIEW AND INITIAL PERFORMANCE**

by

Gérard R. Noury

(Directorate of Radio Communications Technologies)
(DRL)

DISTRIBUTION STATEMENT A
Approved for public release;
Distribution Unlimited

DTIC
SELECTE
FEB 25 1992
S B D

CRC REPORT NO. 1423

July 1991
Ottawa

This document was prepared for and is the property of the Department of National
Defence, Research and Development Branch under Project No. 041LB.



Government of Canada
Department of Communications

Gouvernement du Canada
Ministère des Communications



da

92-04075



92 2 18 058

COMMUNICATIONS RESEARCH CENTRE

DEPARTMENT OF COMMUNICATIONS
CANADA

**AN ADAPTIVE, PACKET-SWITCHED HF DATA TERMINAL
-FUNCTIONAL OVERVIEW AND INITIAL PERFORMANCE**

by

Gérard R. Nourry

(Directorate of Radio Communications Technologies)
(DRL)

CRC REPORT NO. 1423

July 1991
Ottawa

This document was prepared for and is the property of the Department of National
Defence, Research and Development Branch under Project No. 041LB.

**An Adaptive, Packet-Switched HF Data Terminal
- Functional Overview and Initial Performance**



Accession For	
NTIS GPA&I	<input checked="" type="checkbox"/>
DTIC TAB	<input type="checkbox"/>
Unannounced	<input type="checkbox"/>
Justification	
By _____	
Distribution/	
Availability Codes	
Dist	Avail and/or Special
A-1	

ABSTRACT

This report describes the first-prototype version of an automatic, adaptive HF data terminal developed from 1983-1986. The terminal's main forms of adaptivity include a real-time channel evaluation and channel selection mechanism, an adaptive link protocol for channel optimization, and a fully distributed and adaptive routing algorithm for the selection of routes in an HF network. The terminal design is characterized by a suite of robust, low-overhead, adaptive protocols that work in low-bandwidth, error-prone and time-variant environments. The terminal's performance is illustrated with results from tests over short and long HF links carried out in Fall 84 and Winter 85-86.

RÉSUMÉ

Ce rapport décrit la première version prototype d'une console automatique et adaptative pour systèmes de communication par ondes HF. La console fut développée durant la période 1983-1986. Les principales formes d'adaptation de ce système incluent un mécanisme d'évaluation et de sélection de canaux en temps réel, un protocole adaptatif inter-liaison afin d'optimiser l'utilisation du canal, et un algorithme adaptatif et distribué de sélection des liaisons dans un réseau de liaisons HF. Ce système est caractérisé par un ensemble de protocoles permettant d'opérer efficacement dans un environnement sujet à des fluctuations temporelles de niveaux de signal et où les voies de communication sont contraintes à des taux élevés d'erreurs de transmission et ne peuvent occuper qu'une faible largeur de bande radio. Les performances du système sont illustrées et des résultats de tests expérimentaux sur de courtes (automne 1984) et longues (hiver 85-86) liaisons HF sont également présentées.

EXECUTIVE SUMMARY

Although high frequency radio has evolved relatively little compared to other communications means, it offers unique advantages to military communications systems. HF is a means of long-range and survivable communications, offering worldwide coverage.

To meet new and emerging HF communications requirements, DND's Directorate of Communications Engineering and Maintenance sponsored, in 1983, the "Strategic HF Data Network" task. This task was an effort to improve on existing HF communications performance in connectivity, speed, throughput, reliability and survivability, and to investigate new approaches to HF communications.

A different approach to HF communications has been developed -- an adaptive-system approach. Whereas much of the work in HF attempts to improve specific components (e.g. HF modems), and whereas recently new systems (e.g. Autolink, Selscan) have begun to include real-time channel evaluation techniques, the system described in this report uses a combination of adaptive and packet-switching techniques to improve overall HF communications performance.

Adaptive techniques have been implemented in a vehicle called the HF data terminal. The terminal is characterized by adaptivity at all levels of its design, including a real-time channel evaluation and channel selection mechanism, an adaptive link protocol for channel optimization, and a fully distributed and adaptive routing algorithm for the selection of routes in an HF network. The adaptivity is implemented via a suite of robust, low-overhead, adaptive protocols that work even in low-bandwidth and error-prone environments. With the exception of channel evaluation/selection, all forms of adaptivity are dynamic and not negotiated over HF links.

The data terminal has been tested over short and long HF links in the fall of 1984 and the winter of 1985-86. The most recent tests were conducted over the Carp-Penhold link. The experimental results are very encouraging. They show that, using only five frequencies, a high-speed (2400-bps) HF channel was available more than 90% of the time. The terminal error-free throughput over that link ranged from 100-300 bps and can be doubled by a change in the experimental configuration. The throughput result was obtained without the use of forward error correction and relied on the terminal's adaptivity to provide error-free communications. The experimental data also suggests that the terminal could make efficient use of higher data rates (e.g. 4800 bps) over CFCC links.

The HF data terminal, in its current version, already offers a one-order-of-magnitude, or better, improvement in error-free throughput over existing strategic HF communications systems. It also offers a number of operational advantages including automatic operation, graceful performance degradation, interfacing to a wide variety of HF radio equipment, and solving the problems associated with the "two-frequency" HF military operation schedule.

The HF data terminal is being enhanced with the addition of an adaptive serial modem, an interface to a military cryptographic device and various design improvements resulting from the analysis of the experimental data. It is expected that these enhancements, in addition to making the system more robust, will stabilize its throughput and will increase it by a factor of at least two.

Although a few adaptive HF communication systems are now advertised, they include real-time channel evaluation techniques only. Also claims of adaptive HF networks have recently been made. Such "networks" are often only an assembly of links and do not permit routing of information and, to our knowledge, none of those systems has been demonstrated.

This project's contribution to the improvement of HF communications is to have designed and implemented robust and adaptive algorithms or protocols that dynamically optimize the use of an error-prone, time-varying channel, to have demonstrated the feasibility of packet switching in the low-bandwidth HF environment and to have designed some tools for the management of fully distributed, adaptive HF networks. These concepts have been put together in an HF communication system.

Further experiments with this new technology, especially over trans-auroral and polar cap circuits and in periods of high solar activity, are required to find out if it can meet all new and emerging military HF communications requirements.

This project has generated a great deal of interest in the international community. Numerous offers to collaborate in the project and requests to be kept informed of the latest developments have been received.

EXECUTIVE SUMMARY	V
1. INTRODUCTION	1
2. PROJECT BACKGROUND	2
2.1 Military and civilian needs for improved HF communications.....	2
2.2 Recent efforts in HF communications developments	3
2.2.1 Some equipment advances.....	4
2.2.2 Some recent system developments.....	4
2.3 Limitations of current military HF communications methodology	5
2.4 The adaptive system solution	6
2.4.1 The choice of adaptive techniques	6
2.5 Summary	7
3. THE HF DATA TERMINAL	8
3.1 Four characteristics of HF communications.....	8
3.2 The selection of adaptive techniques	9
3.3 The design principles	9
3.4 The HFDT design	10
3.4.1 Hardware and software architectures.....	10
3.4.2 The design characteristics.....	11
3.4.2.1 The physical level	11
3.4.2.2 The link level.....	11
3.4.2.3 The network level	12
3.4.2.4 The transport level.....	12
3.5 The functional aspect.....	13
3.6 The operational characteristics	14
3.7 Summary	15
4. THE HFDT EXPERIMENTAL EVALUATION	16
4.1 The short-link experiments.....	16
4.1.1 The results	17
4.2 The Carp-Penhold experiments.....	17
4.2.1 The results	18
4.3 Discussion.....	20
5. FUTURE WORK.....	21
5.1 Short-term developments.....	21
5.2 Longer-term developments.....	22
6. CONCLUSIONS	23
REFERENCES	24

1. INTRODUCTION

The Department of National Defence (DND) uses HF radio to meet its tactical and strategic communication requirements and to provide common users communications in times of crisis. DND's and NATO's current and emerging requirements for HF communication impose new operational constraints and place greater operational, reliability, and survivability demands on this type of communications. These new requirements can only be met through significant improvements in HF communications. Accordingly, in 1983, DND through its Directorate of Communications Engineering and Maintenance (DCEM) sponsored the "Strategic HF Data Network" task. This task was an effort to improve on existing HF communication characteristics such as connectivity, speed, reliability and survivability, and to investigate new approaches to HF communications.

As a communication medium, HF radio presents some unique advantages to the communicator. It represents a means of low-cost and long-range communication. Especially significant to the military user is the inherent survivability and worldwide coverage of HF communications, and the portability of HF systems. These features are associated with unique, at times severe, communication problems due to the characteristics of the communication path and its time and space variability. Some of those problems, e.g. multipath, frequency dispersion, etc., increase in complexity with increasing transmission rate. The HF communication dilemma is thus: HF communications presents unique capabilities but these come associated with unique problems.

Much of the R&D, resulting from the renewed operational interest in HF radio as an alternative and as a complement to terrestrial and satellite communications, is centered on the application of microelectronic devices to implement complex signal processing functions long recognized as a key to more reliable HF communications. Typically, the work has been concentrated on producing better HF modems, receivers, antenna couplers, etc. More recently, emphasis was rightly put on the use of real-time channel evaluation techniques (RTCE) to improve HF communications.

This task used a different approach to HF communications -- an adaptive-system approach. Whereas much of the work in Canada and abroad attempted to improve specific components or methods of communicating over HF, this task used adaptive techniques and packet-switching principles to improve link/network connectivity and performance. In other words, under the premise that better HF modems, more radiated power, better receivers, more powerful FEC, etc. are not always the solution to better HF communications and, in fact, are sometimes not allowed because of operational constraints, this task used a "gentle" approach whereby a system always tries to make the best possible use of the propagation conditions (by adapting to them) and of the equipment.

This report discusses the main ideas in this approach to HF communications and describes the basic features of the HF data terminal. The performance of the terminal is illustrated with results from on-air experiments carried out in the fall of 1984 and the winter of 1985-86. The report concludes with a specification of the immediate and future work required to develop this new technology further.

2. PROJECT BACKGROUND

High-frequency radio represents a means of low-cost and long range communication. Some of the most significant attributes of the high frequency radio channel are its inherent survivability, its ability to provide communications in areas where other communications means are non-existent, impossible or impractical to use, and its ability to provide reliable long distance communications via skywave propagation. The combination of the survivability characteristics and the worldwide coverage of HF communications with the portability of HF systems makes HF radio a rather unique communication means and renders it very attractive for military use.

These unique features come at a cost. HF communications suffer from a number of problems. The frequencies which will propagate over a given path and the quality of the resulting communications depend strongly upon ionospheric conditions that are difficult to predict on an hourly or daily basis. The channel capacity exhibits large and largely unpredictable variations due to the characteristics of the propagation path (made up of many ray paths) and their time and space variations. Communications are affected by fading, co-channel interference and noise, and the signal exhibits dispersion and distortion.

This is the HF communications dilemma: HF radio communications presents some unique capabilities but come with several unique problems. Solutions must be found to improve on HF communications in the areas of connectivity, speed, reliability and survivability.

For more than a decade, with the advent of satellite communications, little developments took place in HF communications. This moratorium on HF developments has now ended because of the costs associated with satellite communications, their limitations in supporting military and civilian high latitude communications requirements effectively, and the recognition of their vulnerability.

This chapter reviews some military and civilian requirements for HF communications, the developments in this area since the end of the moratorium and current efforts in HF communication developments. The limitations of the current military HF communications methodology are also reviewed, and a solution using an adaptive-system approach is proposed.

2.1 Military and civilian needs for improved HF communications

Important applications of HF communications include aircraft, ship and field operational communications, and land-to-mobile stations. Military and civilian applications of HF in these areas are often very similar, especially so for strategic communications. Although military tactical and civilian field operational uses of HF often differ at the present time, technological advances in HF communications will likely bring them closer.

High frequency radio will play a major role in future military communication systems. The vulnerability of satellites makes many nations consider HF as a primary military communication medium even when satellites are part of their communications infrastructure. Currently, HF is the first backup to satellite communication for beyond-line-of-sight (BLOS) ranges in the event of satellite failure or destruction and as a post-nuclear-blast communication medium. HF radio has also been selected as the primary intra-task-force communication medium for extended-line-of-sight (ELOS) ranges in Naval communications.

There is a requirement for a stand-alone defence communications facility to sustain operations independent of catastrophic landline failures and to provide for emergency government communications facilities during a time of national crisis. The survivability of HF makes it a prime candidate for such applications. HF plays a role in the Emergency Communication Network (EMGOV) in Canada and in the Minimum Essential Emergency Communication Network (MEECN) in the United States.

Other military requirements, in which HF could play a major or backup role, include providing air-ground-air (A/G/A) communications to long-range-patrol (LRP) and other aircraft, providing communications to and from remote sites (e.g. in the Arctic), and meeting tactical communication requirements, both long- and short-range.

An emerging use of HF in military networks is to provide network reconstitution. In recent years, the military have increased significantly their dependence on landline-based computer/communication networks. These networks are sensitive to the destructive influence of electromagnetic pulses (EMP) produced by atmospheric nuclear explosions. HF communications can be used not only as a backup for such networks, but also as a primary means to reconstitute damaged networks. Advances in HF communications networking technology could turn this into a rapidly developing HF application.

There are a number of non-military applications and requirements for HF communications. There is a requirement for HF communications to and from planes flying over the North Pole and across the oceans. Currently, there are occasions when pilots fly a few hours without any communication means whatsoever. The International Civil Aviation Organization (ICAO) has a requirement for communications with third-world countries. HF has been proposed as the medium.

Foreign Services or the Diplomatic Corps are major user of HF communications. An HF service is provided between embassies and missions in various countries as well as directly back to the home country. Often, as in the case of communications with third-world countries, the only alternative to this service is expensive, low-rate (50-bps) and poor quality telephone lines to pass teletype traffic.

Many small companies use HF to avoid the cost of long-distance telephone charges of the carrier networks. In mining and exploration operations, HF radio is often used in the initial stages of development of their operation because of the delays in establishing regular telephone service using microwave relays or land lines.

In many of the applications above, the data traffic is limited to 75 bps or less. HF communications can be adversely affected by a number of factors [e.g. 15-21]. Significant advances in HF techniques are required to improve the present performance and the reliability of such communications. These are necessary in order to meet the new requirements and to enhance the applicability of HF.

2.2 Recent efforts in HF communications developments

With the resurgence of interest in HF and the advent of powerful and inexpensive microprocessors and digital signal processors, significant equipment and systems advances have been made. Some interesting equipment advances are highlighted below and the discussion then proceeds to recent and current systems developments.

2.2.1 Some equipment advances

Improved HF modems have contributed significantly to more reliable and better HF communications. They have evolved from data rates of 75 bps to 2400 bps. New modems typically include many digital signal processors. Two approaches are being pursued in modem design: serial (single-tone) and parallel (multi-tone) modems. These have differing capabilities to combat the effects of multipath, fading, Doppler shift and spread, and other signal characteristics. However, good HF modems alone are not sufficient to guarantee a high degree of availability and reliability in HF communications.

Improved linearity of receiver front ends has greatly reduced the deleterious effects of inter- and cross-modulation but receiver sensitivity has not been improved over the last decade and the receiver reliability has, if anything, decreased. New receivers are more frequency agile and include useful operational features such as remote control of the receiver and built-in test circuitry.

Other equipments have not evolved as significantly. Newer transmitters generally have better frequency agility, remote control functions and built-in test circuitry. Solid-state transmitters are becoming widespread and more reliable. Transportable and mobile antennas have advanced little in the last decade except for automatic tuning of narrowband antennas. Good chirp sounders, although expensive, are now available for oblique sounding and frequency management purposes.

Significant advances have taken place in HF voice technology [1,2]. An example of this is the vocoder built at CRC. Bryden (private communication, 1986) has demonstrated good quality 2.4-kbps LPC-10 voice over an HF link.

2.2.2 Some recent system developments

Real-time channel evaluation (RTCE) has emerged as a valuable tool in the selection of good communication channels to improve the performance of HF communication systems. In short, RTCE is the attempt to evaluate, in real time, interference and propagation problems. It is normally complemented with a method to deal with them automatically. Some new systems include RTCE components. The CHEC (Channel Evaluation and Call) system [3] developed at CRC in the mid-sixties was the forerunner of such systems. More than a decade later, the CHEC system was followed by another CRC development, the RACE system (Radio-Telephone with Automatic Channel Evaluation) [4,5]. RACE was followed by the HF Data-Message Terminal [6,7,8] now being used by various Government organizations. This effort was paralleled by another CRC development [9] which used higher speed (300-bps) modems and X.25 protocols over HF links and which led to the current project.

The Harris Autolink and Rockwell Selscan adaptive communication systems are systems that provide automatic HF link establishment through the combined use of receive channel scanning, selective calling, link quality analysis (LQA) and automatic radio control. The main difference between those systems is the extent of and the parameters measured in their LQA. When they are used with the appropriate modems, link speeds can be as high as 2400 bps.

A number of other systems exists or are in development. In general, they are characterized by some form of adaptivity (usually RTCE) and often provide low throughput because of their design for survivability in a stressed environment. Examples of such

systems are the Hughes adaptive HF radio, Plessey's AiCORN and some NATO systems. Since Regency Net, being designed by Magnavox, has received wide publicity, a few comments on this system are in order.

The Regency Net project [10] is to develop a theater C2 communications system. It is to provide a survivable radio communications system for fixed or mobile operations in a highly stressed or wartime environment. A great deal of emphasis has been placed on the modular design and on eventual ECCM capabilities. The system utilizes both secure data and secure voice modes and is likely to include frequency hopping. Initial results are far below expectations.

2.3 Limitations of current military HF communications methodology

As is still often the case, manufacturers of HF communication equipment have tended to ignore the characteristics of the propagation medium, adopting a conservative approach to providing reliable communications systems by the use of high power transmitters, repetition of messages and powerful forward error correcting (FEC) codes.

Typical operational military HF communications systems use low data rates (75 bps) that will work over most of the range of channel capacities and increase transmitter power to improve signal-to-noise ratio when required. Little or no attempt is made to vary system parameters such as transmission rate, FEC code rate, modulation scheme, etc. with channel capacity. Further, no attempt is made to vary the quality of service (e.g. error tolerance, permissible delays, specified throughput, etc.) with the requirements imposed by the nature of the traffic.

The HF communications problems are further aggravated by the commonly used "two-frequency" operating schedule based on propagation predictions. This schedule necessitates the use of operating frequencies well below predicted (and actual) MUF values (typically 85% of predicted MUF under quiet conditions) [11,12] in order to allow for the inaccuracies of those predictions [13]. There are few alternatives to the "two-frequency" mode of operation for a manually operated system. This is due to the lack of information about alternative frequencies, the end-to-end coordination involved in a change of frequency (often achieved by means other than HF), the tuning time involved in some existing systems and the reliance on skilled operators to make system decisions.

Problems are associated with this approach to HF communications. The channel is not optimum and is not operated in an optimum manner. Operation well below the actual MUF is likely to produce multimode propagation leading to multipath interference and fading, as well as increasing congestion and mutual interference. High power levels may result in non-linear wave propagation effects (viz. self and/or cross-modulation) and are likely to aggravate the mutual interference problem. Powerful FECs introduce considerable redundancy (typically more than 50%) which effectively reduces the possible information rate under good conditions. Lastly, this methodology is often man-intensive and relies on skilled HF operators.

Techniques such as time, frequency and space diversity are often used to improve HF communications. These techniques work. However, they cost (e.g. spatial diversity) and they often result in wasted resources (e.g. bandwidth, equipment, etc.) because the system is designed for worst case conditions and does not adapt. Newer systems should try to incorporate the essence of those techniques but possibly in a different form.

2.4 The adaptive system solution

A possible solution to the loss of skilled operators in military units, the current operational constraints and the greater operational, reliability and survivability demands being placed on HF communications, is the use of adaptive communications systems. To take full advantage of the medium, a system must be able to respond in real time, or near real-time, to changes in channel conditions. It is essential to develop automated techniques for channel evaluation, frequency selection and transmission optimization in general. Algorithms can also be developed for frequency management, error detection, adaptive error correction, routing of information in a network, etc.

Adaptive systems can contribute significantly to improving HF communications. Adaptive techniques provide tools to combat the time and space variability of the channel and the other factors adversely affecting HF communication. With those techniques, it is possible to take advantage of trade-offs in performance among waveforms, modulation schemes, coding types, data rates, etc. to combat dispersion and distortion effects on the signal. A system based on such techniques can be designed to provide "guaranteed" delivery of information with a specified quality of service, i.e. a specified throughput level, error rate, priority, etc.

Adaptive systems provide other interesting military advantages. Through the use of adaptive techniques (e.g. frequency change, adaptive power), it is possible to ensure low probability of intercept (LPI) by hostile forces. Through using these techniques (e.g. real-time frequency management), the system has an enhanced probability of providing good quality and reliable military communications in the presence of high channel occupancy or jamming.

2.4.1 The choice of adaptive techniques

The design of adaptive systems has been made possible with the advent of low-cost, powerful microprocessors and digital signal processors. There are a number of ways a system can incorporate some form of adaptivity in its design. A list of potential techniques that could be incorporated in a design includes:

- a) adaptive antenna array (e.g. antenna nulling)
- b) adaptive power level
- c) frequency-band selection (e.g. determining LUF-MUF interval)
- d) channel selection
- e) propagation-mode selection (e.g. 1 hop, 2 hops, sporadic E)
- f) adaptive channel equalization
- g) adaptive modulation and coding (e.g. change of waveform)
- h) adaptive FEC (e.g. varying FEC overhead)
- i) adaptive data rate
- j) adaptive routing (e.g. path selection in a network)
- k) adaptive network configuration
- l) adaptive link/network management
- m) adaptive quality of service
- n) adaptive protocols in general
- o) etc.

A system making use of all the listed techniques would be complex, expensive and difficult to realize with today's state-of-the-art in technology. It would also have to go through a very lengthy experimental period to optimize the various algorithms and to prevent instabilities in the system. Moreover, some techniques (e.g. adaptive error

correction) are currently research areas. The choice of techniques to incorporate in a design must thus be narrowed down to the most significant and to the ones that can be practically implemented.

Probably the most significant operational gain in HF communications comes from the use of RTCE techniques with a channel-selection algorithm. Some new systems (e.g. Autolink, Selscan) include RTCE components. Frequency management systems (e.g. the Barry Research system based on their chirpsounder) include, to varying degrees, elements of items c, d and e above. Significant transmission optimization can be achieved by implementing f through j. Interesting military features (e.g. resistance to jamming, LPI, survivability, etc.) can be enhanced by implementing a, b, g, j, k and m.

Frequency-band selection can conveniently be done offline and fed into the system as initial parameters. With the now-available microprocessor implementation of HF frequency prediction programs, it can also be done online. Adaptive antenna array systems are currently being researched and are systems on their own. Issues such as adaptive channel equalization, adaptive modulation and coding and, to a certain extent, link quality analysis (e.g. RTCE), are modern design issues.

2.5 Summary

HF radio communication offers significant operational advantages but these are offset by the difficulty in solving the propagation problems. The current military HF communications methodology often aggravates the communication problems and leads to a reduction in communications effectiveness.

Significant improvements to HF communications and the provision of interesting military features can be realized through the use of adaptive techniques. In addition to the better known features such as resistance to jamming, LPI, survivability, etc., such techniques can provide other features such as adaptive quality of service. Adaptive quality of service could allow a user (or the system automatically) to specify categories of power level, error tolerance, throughput, priority, etc., and compromises between these categories based upon the nature of the traffic.

The choice of adaptive techniques is wide and, with the current knowledge and the state-of-the-art in technology, a system must limit itself to a subset of techniques. Through the incorporation of some of the more significant adaptive techniques, it is possible to improve on existing HF communications performance in connectivity, speed, throughput, reliability and survivability. This is what this project has done.

By adapting an adaptive-system approach, using the current technology and developing the necessary concepts and algorithms, this project has produced an overall adaptive communication system that provides significant improvements in performance Over existing HF Communication Systems.

3. THE HF DATA TERMINAL

This project uses a system approach to HF communications, characterized by the use of adaptive techniques. Rather than relying only on better HF modems, more radiated power, more powerful FECs, etc., which are not always permissible because of cost and operational constraints, this project uses a "gentle" approach, whereby a system always tries to make the best possible use of propagation conditions and of the equipment to improve HF communications.

3.1 Four characteristics of HF communications

The design of a communication system starts with the recognition of the strengths and weaknesses of the propagation medium and the characterization of the communication channel. In addition to the large and largely unpredictable time and space variations of the propagation-medium characteristics and the associated variations in channel capacity, four general characteristics of HF communications are of utmost importance for the intended application. They are

- a) low available bandwidth
- b) error prone environment
- c) multicast nature of HF communication transmissions
- d) non-reciprocity of HF communications

The effective bandwidth available on HF is variable and the current state-of-the-art is 2400 bps for digital communications. The probability of a bit error, often referred to as the bit error ratio (BER), ranges from 5×10^{-1} to 10^{-6} on HF links. If there is such a thing as a typical BER range, it can best be set at 5×10^{-2} - 5×10^{-3} when the channel is available.

The nature of HF communication transmissions depends upon the directionality of the antenna being used. For short-to-medium range communications (up to 1000 km), omni-directional antennas are often used and result in broadcast transmission. For medium- (say > 500 km) and long-range communications, directional antennas are generally used. Typically, the beamwidths of directional antennas range from 60° to 120° . Such beamwidths produce a spatial coverage, at a distance x from the transmitter, of the order of x . This results in the possibility for a number of receiving stations (up to 1000s of kilometers apart) to hear the transmitted signal. This type of transmission, being neither of a point-to-point (ppt) nor of a broadcast type, is hereafter referred to as being of a multicast nature.

Reciprocity cannot be assumed over an HF link. That is to say, even if user A receives user B's transmissions on frequency F_{ab} , it may well be the case that user B cannot receive user A on the same frequency. In fact, even if the best propagating frequencies (say F_{ab} and F_{ba}) in each direction are selected, one cannot assume bidirectional communications because of the local noise levels at each station. This non-reciprocity of HF communications, as will be seen below, has far-reaching consequences on the design of a communication system.

3.2 The selection of adaptive techniques

A number of candidate adaptive techniques have been listed in Section 2.4. This project used a limited subset of all the adaptive techniques likely to produce the desired improvements in HF communications. The reasons are that current knowledge in adaptive techniques is incomplete, that one can do no better than use the state-of-the-art in technology, and that the level of difficulty was kept within reason to ensure a successful outcome in a reasonable time.

Initially, the selection was limited to a simple RTCE technique, channel selection, adaptive link/network management and adaptive protocols (this includes d, j, k, l and some m and n of section 2.4). This selection of techniques is not arbitrary.

RTCE techniques represent one of the most significant means to improve HF communications. A simple error-counting RTCE technique was included because of its ease of implementation and the good results it yields, but mostly because inband link quality analysis is (here) considered to a large extent as a modem function. A high-speed serial modem has been designed at CRC and includes adaptive channel equalization, and will eventually provide link quality analysis data. This modem is currently being integrated in the HF data terminal design.

Frequency changes do not occur continuously and therefore a means to optimize the usage of a channel is required. This is done by adaptive link operation which, through transmission optimization, contributes to enhanced link connectivity and performance.

Packet switching techniques are a main contributor to increased connectivity, robustness and survivability of HF communications. Figure 3.1 depicts a hypothetical HF network in which individual links use different frequencies. Through routing of information in such a network and repetition of portions of transmissions containing uncorrectable errors, elements of time, frequency and space (path) diversity are provided with a single antenna pair per link. This diversity is provided only as needed and without wastage of resources. Packet switching also permits to use the best propagating frequencies in each region (e.g. the polar cap and the sub-auroral regions in Fig. 3.1), to cross the auroral oval at different points if needed, and to actually traverse the auroral zone underneath the auroral curtain using a relaying node close enough to the auroral zone.

3.3 The design principles

It does not suffice to know the weaknesses of HF communications and the set of adaptive techniques to combat or to circumvent them. Some design principles must be put forward to make efficient use of these tools and to produce a practical, efficient and robust communication system. In addition to the basic adaptive operation of the system described in the previous section, the main design principles are:

- a) as much as possible, the adaptivity should not be negotiated over a link and end-to-end time-synchronized operations should be reduced to a minimum;
- b) built-in adaptivity should be such that whenever a change of an adaptable system parameter is required, the change should produce a significant effect (i.e. the "granularity" of the effect should not be too fine). Furthermore, the number of possible changes should be limited;
- c) protocols should introduce a minimum of transmission overhead and, in particular, the link level protocol should initially be point-to-point in nature;

- d) link and network management should be simple and robust and should introduce a minimum of transmission overhead;
- e) since it is not always possible to correct all errors on an HF link, a FEC scheme powerful enough to cope with "normal" channel error characteristics should be complemented with an automatic repeat request (ARQ) scheme (i.e. hybrid FEC/ARQ);
- f) unnecessary (re)transmissions of information should be eliminated;
- g) the system design should be as independent as possible of the radio equipment and HF modems used.

Most of these design principles are self-explanatory and are dictated by the low-bandwidth and error-prone environment in which the system has to evolve. They reflect the emphasis put on the optimum use of the available resources (e.g. bandwidth). Two of those principles do require comments.

A point-to-point link level protocol reduces the problems associated with the multicast nature of HF transmissions by making the channel act logically as a point-to-point channel. A future system could try to take advantage of the multicast transmissions, but this promises to be a complex task.

Although the elimination of unnecessary (re)transmissions of information seems to be a rather trivial design principle, it is fundamental to this system's design. It goes beyond the use of a selective-repeat ARQ mechanism and is reflected in the structure and in some of the functions of the various layers' protocols.

3.4 The HFDT design

3.4.1 Hardware and software architectures

The vehicle implementing the adaptive communication functions is called the HF Data Terminal (HFDT). From a hardware viewpoint, the data terminal is simply a powerful microcomputer system. The current hardware design is depicted in Figure 3.2. The design is Multibus-based (IEEE 796). The most important components are the main processor board (Intel 80286), a disk controller and a few serial communication boards.

The software architecture is based on the International Standards Organization (ISO) Open Systems Interconnection (OSI) model. The physical, link, network, transport and a generalized application layers have been implemented. For reasons of processing efficiency the OSI software design guidelines were not followed closely at the physical and link levels. There, the emphasis was put on modular software and minimum motion of data between these layers. The other layers conform to the OSI guidelines.

The main functions included in the data terminal architecture are shown on Figure 3.3. On this figure, only the spectrum management function at the network level has not been implemented yet. The data terminal architecture is characterized by adaptivity at each of its layers. Channel adaptation and transmission optimization occur mostly at the physical and link levels. Packet-switching functions (e.g. path selection or routing, priorities, etc.) take place at the network and transport levels.

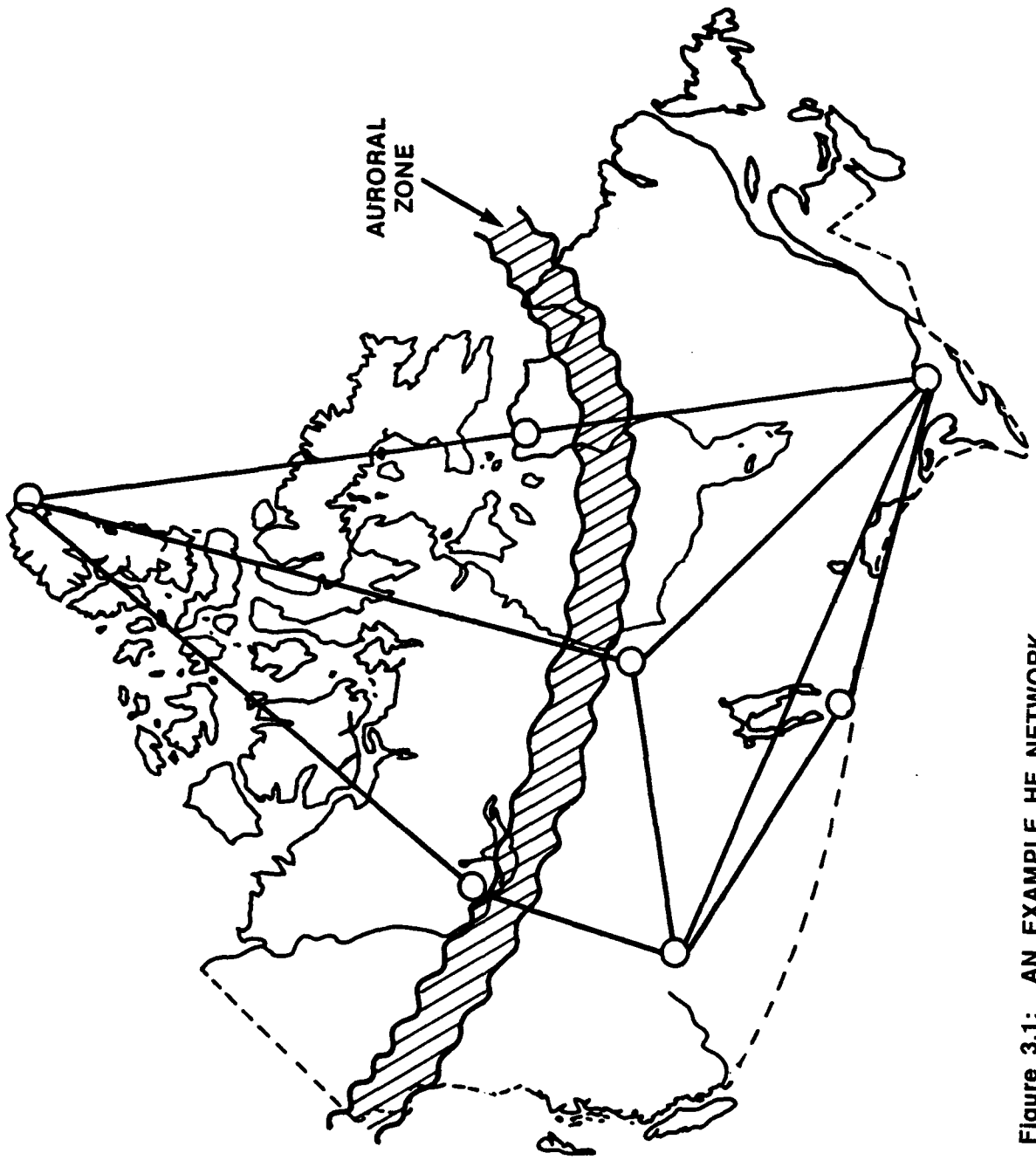

Figure 3.1: AN EXAMPLE HF NETWORK

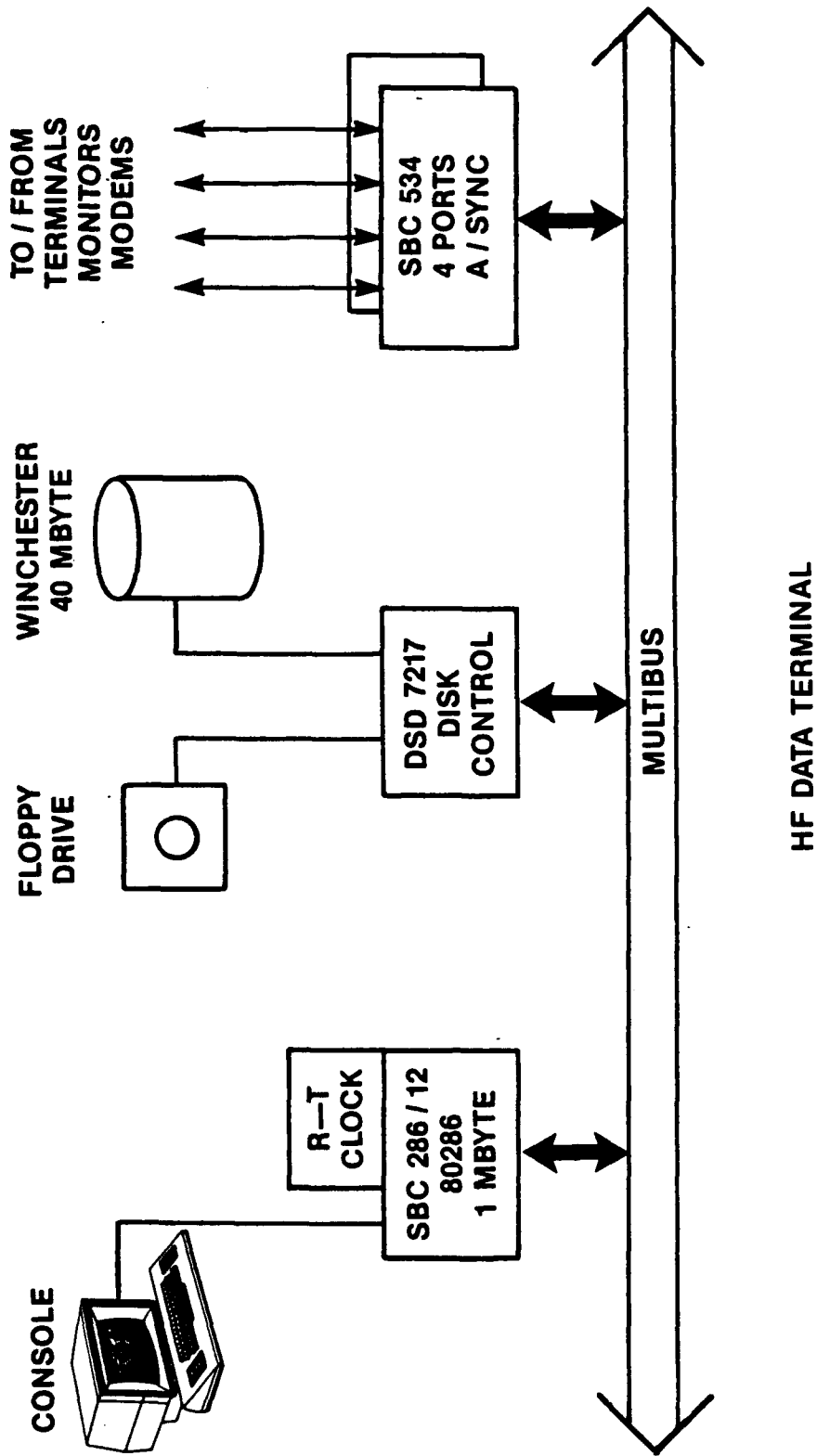

Figure 3.2: THE HFDT HARDWARE ARCHITECTURE

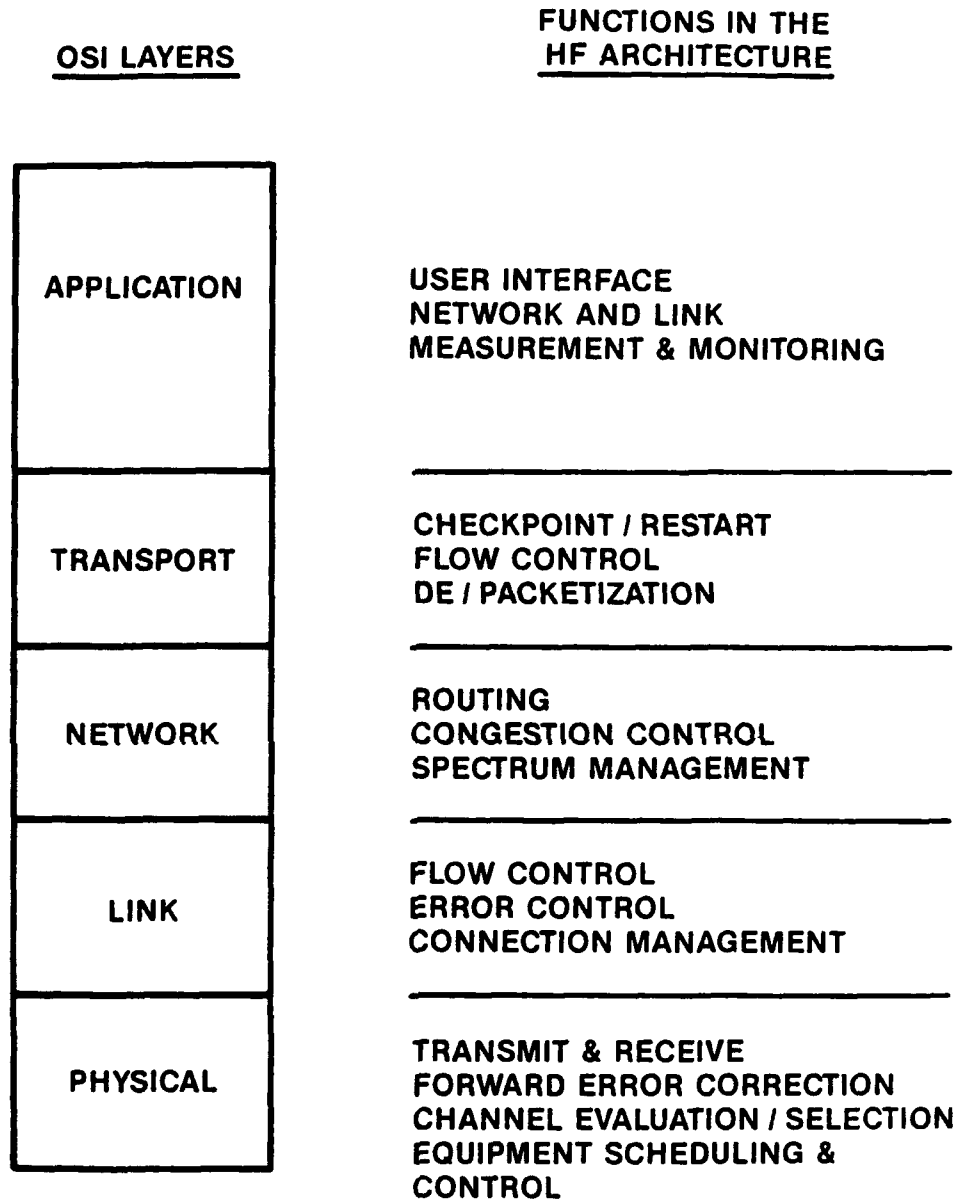

Figure 3.3: THE HFDT SOFTWARE ARCHITECTURE

3.4.2 The design characteristics

The HF data terminal is a communication system and a description of its design is thus lengthy and inappropriate here. A discussion of the design decisions and a presentation of the design specifications are left for a subsequent report. Below, only the main characteristics for each layer are briefly discussed.

3.4.2.1 The physical level

The main characteristic of the physical-level design is the presence of a real-time channel evaluation (RTCE) and channel selection mechanism which permit the data terminal to adapt to changes in propagation conditions. End-stations on a link periodically exchange test bit-patterns on each assigned frequency and, upon reception, determine the best received frequency by counting the number of errors in the pattern. Based on this result and on the past history of the channel, the stations inform each other, on each assigned frequency, of the frequency to be used for transmission.

This simple error-counting RTCE technique is easy to implement and yields good results (see Chapter 4). A CRC-designed adaptive HF serial modem, currently being implemented in the HFDT design, will provide more adaptivity at the physical level as well as dynamic RTCE techniques. The serial modem includes adaptive channel equalization and will eventually provide extensive link quality analysis data dynamically.

Other features of the physical level include remote control of radio equipment and modems, and a hybrid FEC/ARQ scheme. Standard functions such as channel access, synchronization, etc. which are fundamental to any communication system, often become complex problems in the error-prone and noisy HF environment. Good schemes to accomplish these functions are essential to provide overall system efficiency. These issues will be discussed in a subsequent report.

3.4.2.2 The link level

The main characteristic of the link level is a specially designed robust, bandwidth-efficient and adaptive link protocol which allows dynamic optimization of the channel. This protocol varies the data transmission (or frame) structure and length to adapt to the quality of the channel. When propagation conditions deteriorate, the protocol reduces the frame length and changes to a higher-overhead state to ensure good error detection, to minimize potential data losses and to minimize the amount of information that might have to be retransmitted. When propagation conditions improve, the protocol decreases the overhead and lengthens the frames to maximize throughput on that link. This form of adaptivity is dynamic and not negotiated between stations.

Built into the protocol is a mechanism that allows a transmitting station, upon reception of data from the other end of the link, to find out how successful its own transmissions were and thus to take appropriate actions to improve upon them. Actions are taken dynamically and unilaterally by the transmitting stations. The receiving stations, upon decoding the frame header, know how to interpret the frame content.

This protocol is robust and bandwidth-efficient. Total loss of a frame of data can result only from unrecoverable errors in the frame header (a 6-byte field). Unrecoverable errors in any other portions of the frame result in partial loss of data which can be recovered through automatic retransmission. The protocol uses a single frame type to accomplish all its functions including data communication, link establishment/closing and

link management/maintenance functions. For comparison, the international standard HDLC (High Level Data Link Control) protocol uses 25 types of frames for the same purposes and unrecoverable errors in any portion of the frame result in a total loss of that frame. Thus, HDLC is highly inefficient in a low-bandwidth environment and does not work when the error rate exceeds 10⁻³.

The current protocol offers a number of other advantages over many widespread link protocols. It is conceptually simple, easy to implement, code-independent and does not require bit or byte stuffing. It can best be described as a bit/byte-count protocol. Half-duplex or full-duplex implementations differ little since both link directions are decoupled.

3.4.2.3 The network level

The main network level adaptivity takes the form of a fully distributed, adaptive network routing scheme. This routing algorithm allows each network node to operate autonomously without the use of a central control station and ensures that no node depends upon any other node to obtain routing information. In other words, no "master" station is needed with this concept; destruction, failure or addition of a network node, or loss of connectivity to a node does not affect the rest of the network.

The routing algorithm is based upon a minimum-relay (or minimum-hop) metric. Each station constructs and updates its image of the network connectivity via the normal flow of packets passing through it. Only a few additional network management types of packets may be used to reflect lost links, node addition or node removal in the network connectivity matrix.

The network is self-configuring. At network startup time, the network level needs to know only the maximum possible number of nodes in the network and the maximum possible number of physical links at the local node. A "startup" packet is then sent on each possible physical link to establish initial connectivity status information (including whether the link is bidirectional or not) to its immediate neighbours. The network is then ready for operation. The normal data packet flow and a "looking-for-node" packet will suffice to determine all routes.

Each node selects, on a packet basis, the best route to reach the final destination and passes the packet to its neighbour along that route. The same route selection process takes place for each packet at each intermediary node along the path. There is thus no end-to-end route fixing across the network. A group of packets belonging to the same message or file may travel different routes depending on the network dynamics.

3.4.2.4 The transport level

The transport level introduces a priority scheme for data packets and a checkpoint/restart function. A packet priority scheme is a desirable feature under normal operating conditions and is a required feature under stressed conditions, especially in a military environment.

The checkpoint/restart feature allows the network node originating the traffic to keep track of the data successfully delivered, across the network, to the destination. Should any (major) events occur making it impossible to reach the final destination through any network routes, the originator will stop sending data, periodically check if the problem has been resolved, and if so, will resume sending data at the point it was when the problem occurred. Such a mechanism is necessary because of the low bandwidth of the HF channel. Not doing so could result in a "snowball" effect wherein a system could use hours or days to pass a message.

3.5 The functional aspect

The HF data terminal system alternates between two phases: a channel evaluation/selection phase and a data communication phase. Periodically, the system interrupts its data communication operations to proceed with an evaluation of its assigned channel, in each direction and on each link. End-systems on a link then inform each other of the resulting selected channels and resume data transmission operations. This is the only time-synchronized link/network operation in the HF data terminal system. Other forms of adaptivity are dynamic and not negotiated over the air.

User data transmissions occur during the communication phase. During this phase, after having selected the best communication channel, the system attempts, until it succeeds, to deliver user data to its destination in an error-free manner. While doing this, the system dynamically optimizes its operation for the quality of the communication channel and dynamically makes the appropriate decisions, based on the current network connectivity, to reach the final destination in the most efficient manner. The sequence of operations taking place in this process can be best understood by following the data flow in the system (see Figure 3.4).

The sender's data terminal accepts messages typed on its keyboard or files from almost any external device (including a host) and stores them. Files or messages are fragmented into packets each prefixed with a transport header T containing the destination, priority, etc., and all the information required to reconstitute the original message.

When ready to transmit a new packet, the transport level selects the packet with highest priority and passes it to the network level. This level examines the destination address and determines the best route to reach it. If a route cannot be found, the network level will circulate a "looking-for-node" packet and upon receipt of an answer from the destination node, will be informed of the route. Once a route has been established, the network level adds its own header N (e.g. containing a network priority) and passes the packet to the link level.

The link level transmits the packet to this node's nearest neighbour along the route to the destination node. According to its current information (updated dynamically) on the quality of the channel, this level may decide to transmit this packet as one or more frames (transmission units), each of possibly different structures and lengths. Each frame is given its link-level header L, passed to the physical level for application of an FEC code, and transmitted as a bit stream over the link.

Each node on the path will, upon reception of an error-free packet by its link level, pass the packet to its network level which will update its connectivity matrix (based upon the information in the packet's network header) and will take one of the following actions:

- if this node is the destination for this packet, the network level will pass it on to its transport level after having updated its connectivity matrix.

- if it is not the intended destination, it will route the packet to another node (using the same sequence of operations described above) after having appended its own address in the packet header.

The transport header of the destination data terminal will send back an (end-to-end) acknowledgement to the sender's transport level for every packet (or group of packets -- this is a system parameter) it has successfully received. It will then use this packet to reconstruct the original message or file.

It is important to note that each packet may be transmitted in a totally different manner on each leg of its journey to the final destination. This results from each link layer involved on this journey always optimizing the transmissions on the link. Likewise, groups of packets belonging to the same file/message, may take entirely different routes through the network. Lastly, at any point during the transmission, the sender may request to checkpoint the packet stream.

3.6 The operational characteristics

The main operational characteristics of the HF data terminal are that it is automatic, it is adaptive, it can operate at high-speed (up to 2400 bps), it can operate in both half or full-duplex mode and it is suited for link and network operation. The network operation is currently for a broadcast TDMA network. All important system parameters can be changed by the operator and extensive link/network online monitoring facilities are provided to the operator. The HF data terminal can interface to a wide variety of receivers, excitors, transmitters and parallel or serial HF modems. The consequences of these operational features are discussed below.

The HF data terminal system is automatic and thus eliminates the need for skilled HF operators. It currently requires one operator when, and only when, the time comes to load data into or extract data from the system. Messages, files or other kinds of data are fed into the system which will then ensure their virtually error-free delivery to the final destination without further operator intervention. The data terminal can be used as an automatic (half or full-duplex) link controller and as an HF network node.

The HF data terminal is adaptive and thus allows optimum use of propagation conditions and equipment resources. Its built-in adaptivity solves the limitations associated with the current method of operation of HF systems. In particular, it solves the problems associated with the "two-frequency" operating schedule by responding in real time to changes in propagation conditions. Through real-time adaptation, advantages can be taken of unpredictable phenomena such as sporadic-E propagation to provide better HF communications. Network route selection enables maximizing connectivity between stations by providing elements of path and frequency diversity. Dynamic link-operation optimization results in optimum use of the bandwidth available.

The HFDT prototype design is flexible and provides extensive monitoring functions. All important system parameters are stored in the system as software and can generally be changed during system operation. For example, the number of potential frequencies and the frequencies actually used for each link are parameters for each network node. The periodicity of channel evaluations/selections, the link data rate, the number of packets between checkpoint/restart operations are also system parameters. Changes in those parameters are reflected in configuration data which, with status and performance data for each link, are available online.

The HF data terminal is, for all practical purposes, independent of the radio equipment and HF modems used. It only requires that such equipment be computer controllable, a general characteristic of modern equipment. The operational differences between HF vendor equipment can generally be accommodated by changes in the system parameters or, for significant differences, by simple software modifications. The terminal can thus make use of better radio equipment as it becomes available. In particular, better and/or faster, parallel or serial HF modems can be interfaced to the system as they become available.

The current network design is for a broadcast time-division-multiple-access (TDMA) network. The HFDT design will soon be able to accommodate frequency-division-multiple-access (FDMA) network operations.

3.7 Summary

The HF data terminal is a generic, adaptive communication system and can thus be tailored for operation in a wide range of HF applications. Its design is characterized by adaptivity at each OSI level implemented. The main forms of adaptivity includes real-time channel evaluation and selection at the physical level, an adaptive link level protocol and a fully distributed, adaptive network-routing mechanism. With the exception of channel evaluation/selection, all forms of adaptivity are dynamic and not negotiated over HF links. Channel evaluation/selection is the only link/network time-synchronized operation between communicating data terminal systems.

The HF data terminal can be used as an automatic, adaptive, high-speed (currently up to 2400 bps), half- or full-duplex HF link controller and/or HF network node. In an HF network, the data terminal does not require a network "master" station and allows node addition and node removal to be done without network interruption. Node failure and recovery are also dealt with automatically and, depending on the network architecture, generally have little impact on network operation and performance.

The HF data terminal can easily be built upon. Other adaptive techniques can be included in its design. For example, a serial high-speed modem, developed on another project, which includes adaptive channel equalization and which will eventually perform significant link quality analysis, is currently being incorporated in the data terminal.

The HF data terminal design is, for all practical purposes, independent of radio equipment and modems. It can thus interface to a wide range of such equipments. The data terminal can therefore benefit from developments in radio equipment and HF modem technology. With some design changes, the terminal can interface to systems like Autolink and Selscan and add functionality to these systems.

The HF data terminal can interface to other networks such as the ADDN, the ARPANET, DATAPAC, etc., as required, provided that the gateway functions between such networks are implemented. The terminal design is compatible with the use of ECCM techniques. The terminal design can be modified for VHF and UHF operations.

4. THE HFDT EXPERIMENTAL EVALUATION

In addition to the laboratory back-to-back system tests following each development phase, the HF data terminal system was evaluated in a series of experiments. Each experiment was followed up by analysis of the experimental data, identification of the system's weaknesses and implementation of design enhancements to correct these weaknesses and to improve the design in general. The experimental programme has consisted of:

- short HF link experiments
- a network emulation
- long HF link experiments.

The network emulation was a laboratory test to demonstrate the correctness of the implementation of the networking features of the system. It involved all the actual equipment, excluding the antenna, in a half-duplex, three-node, TDMA network environment in which the "HF links" were actually coaxial cables. This experiment served its purpose and will not be discussed further.

The emphasis in this chapter is on results from on-air tests of the system. During experiments, the user data was not protected with an FEC in order to obtain error distribution data.

4.1 The short-link experiments

The short-link experiments were conducted from July to early October 1984 between CRC and Petawawa (Landry's Crossing). At this stage in the terminal design, the physical layer, link layer and link monitoring functions as well as the user interface had been developed. The HF data terminal thus had the functionality required to act as an automatic and adaptive link controller.

The main operational and link parameters for these experiments were:

- 136-kilometer link
- no forward error correction
- half-duplex, 2400-bps link operation
- 8 frequencies from 3.1 to 11.6 MHz
- omni-directional, inverted-V dipole antenna
- 100 watts average power
- 16-tone Kineplex-type HF modem (~ 6 watts/tonne)
- solar cycle nearing sunspot minimum.

The experimental configuration is depicted in Figure 4.1. In this half-duplex setup, all equipment is co-located. Transmit and receive equipment share the same antenna. The HF data terminal did not include forward error correction and thus relied upon the adaptiveness of the link protocol and on the automatic repeat request (ARQ) mechanism built into the protocol to provide error-free communications.

Two basic experiments were conducted during this test. The first one was a channel evaluation/selection experiment in which the system, every 3-5 minutes, would sound all channels and select the best one. This experiment lasted for three months from July to October. The second experiment was a throughput experiment and lasted through September.

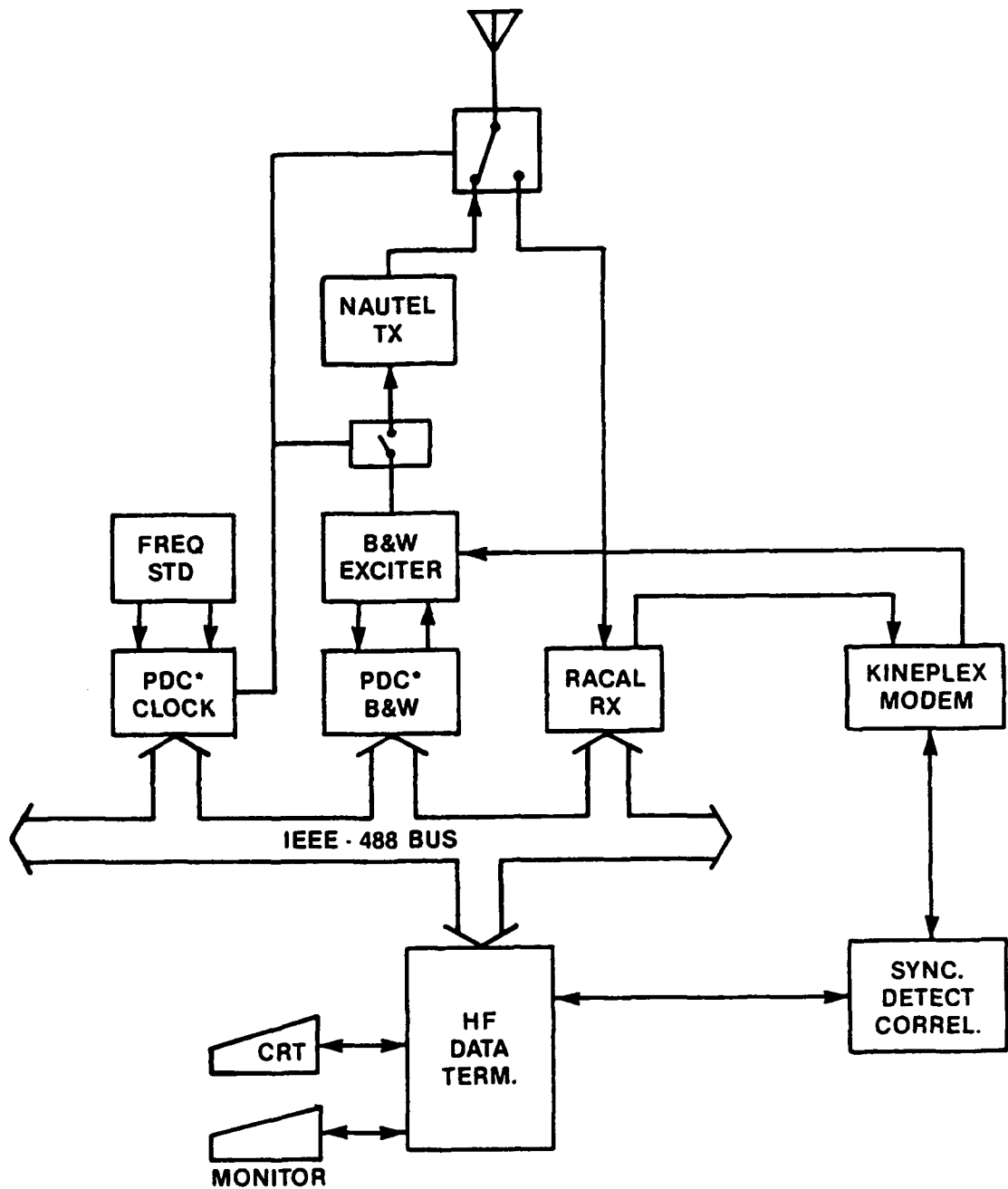

* PROGRAMMABLE DEVICE CONTROLLER

Figure 4.1: THE SHORT-LINK EXPERIMENT
- EXPERIMENTAL CONFIGURATION

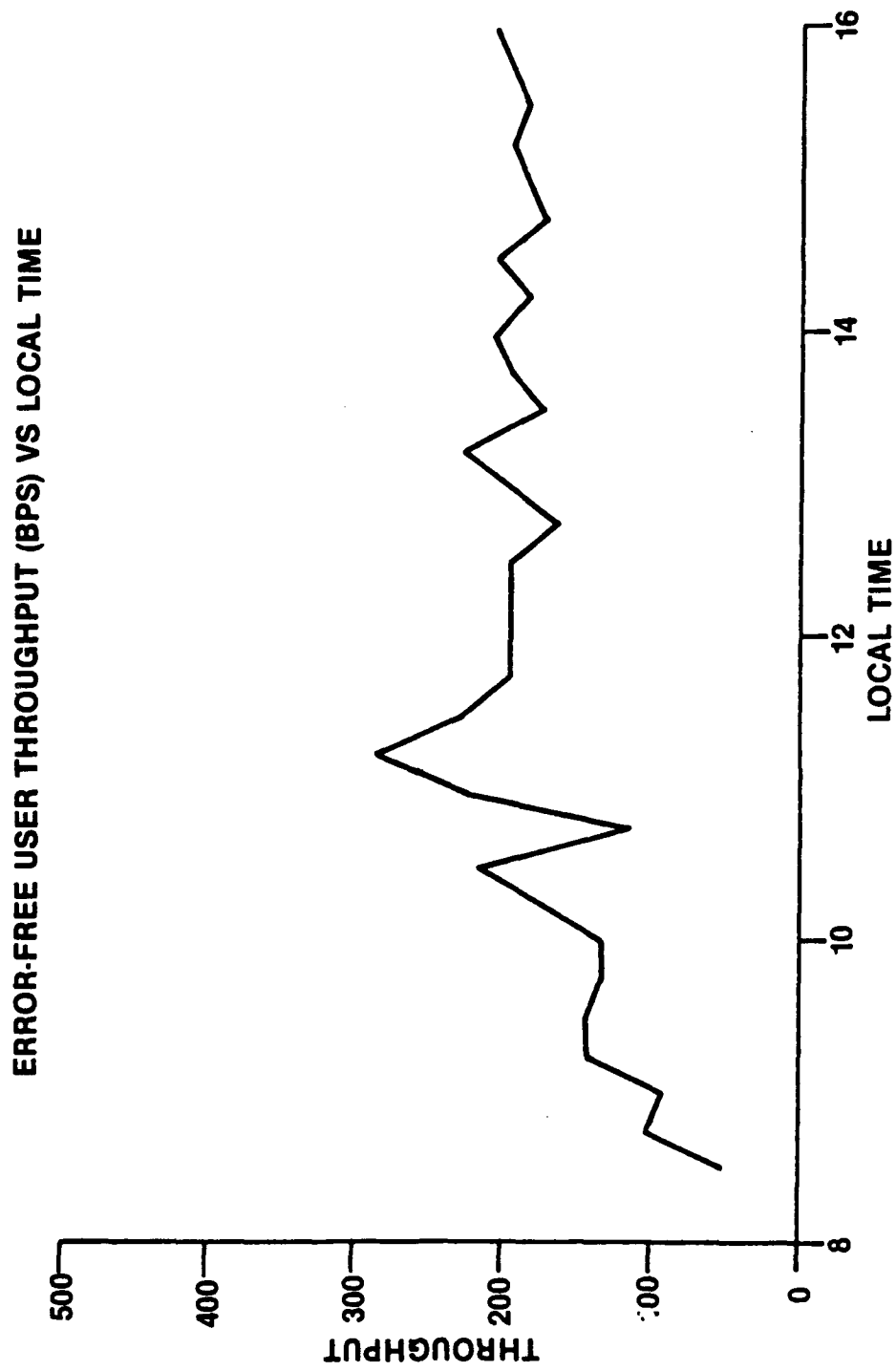

Figure 4.2: THE SHORT-LINK EXPERIMENT
 - TYPICAL THROUGHPUT CURVE (DAY 273)

ERROR-FREE USER THROUGHPUT (BPS) VS LOCAL TIME

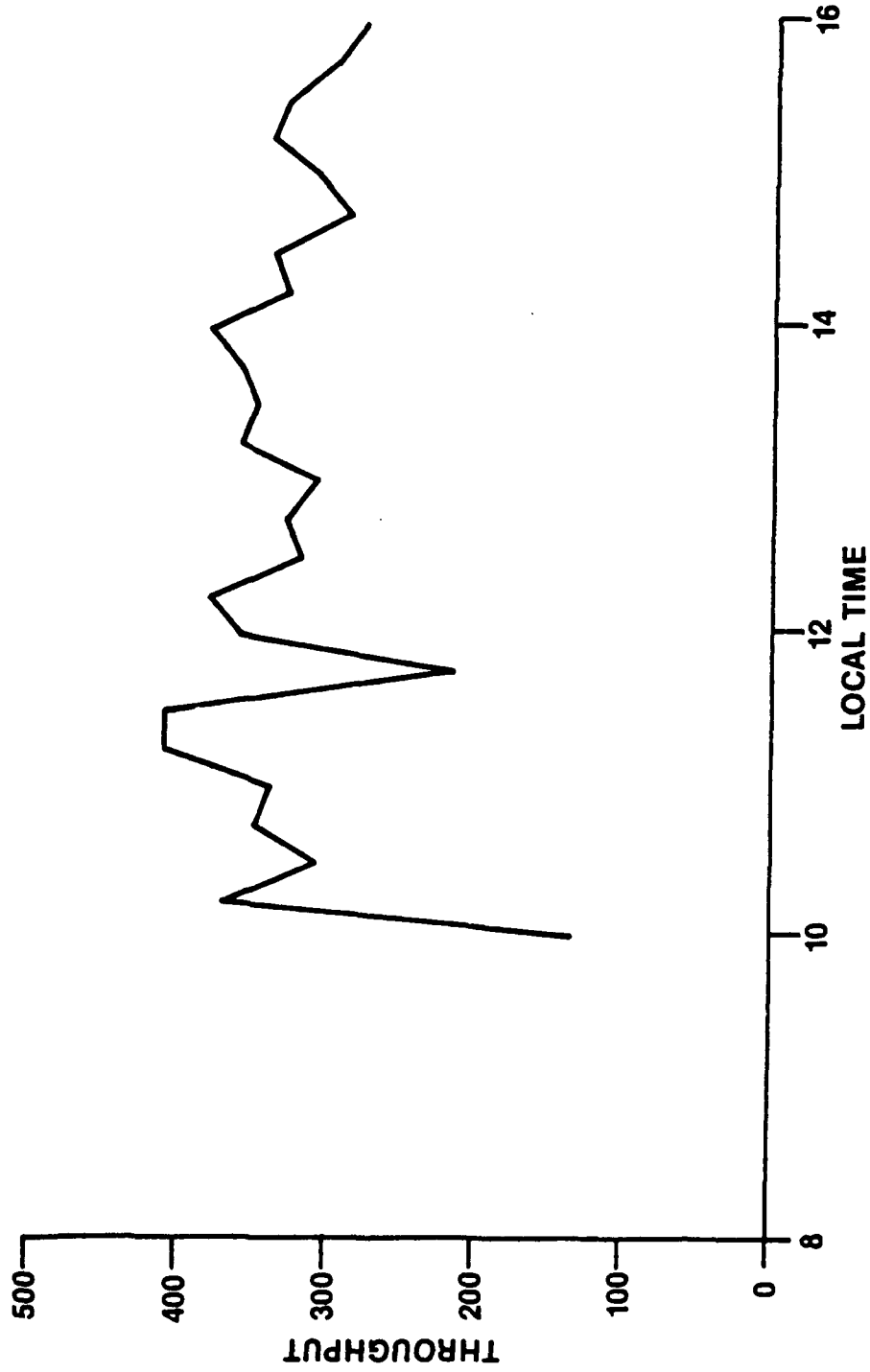

Figure 4.3: THE SHORT-LINK EXPERIMENT
- THROUGHPUT CURVE ON A GOOD DAY (DAY 275)

4.1.1 The results

For the duration of the short link experiments, the daytime average bit error rates (BER) were 10^{-2} at CRC and 4×10^{-3} at Petawawa. This difference is easily explained by the high background noise and interference levels at CRC. Nighttime propagation was generally not possible with the range of frequencies used. A channel around 2 MHz would have been needed for nighttime communications. The experimental period included a two day HF blackout period (reported by other experimenters) during which the HF data terminal was still able to pass information at a reduced rate.

The main daytime results from the experiments were that:

- more than 90% of the time, a communication channel was available at 2400 bps;
- no channel improvements resulted from a reduced data rate (600 bps) in difficult propagation conditions;
- the typical 8-hour average error-free user throughput, in each direction, was 150 bps. It ranged from 80 to 400 bps.

A typical throughput curve and one for a good communication day, are shown in Figures 4.2 and 4.3, respectively. The curves are drawn from fifteen-minute averages of the instantaneous throughput. The variations in throughput on each curve result from varying propagation conditions and communication environment (e.g. noise or interference level), with the system automatically adapting to them.

Although those results were very encouraging, they served to pinpoint deficiencies in the system's design, in particular in its frame-synchronization mechanism and in the channel-access strategy. For example, data analysis revealed a frame-loss rate as high as 50% at times. The experiment was followed by numerous enhancements in the data terminal design to correct the problems above and to enhance its performance in general.

Lower data rate, i.e. 600 bps, did not improve channel evaluation results because the HF modem bit-synchronization scheme does not vary with data rate. It was further demonstrated that the carrier-detection mechanism for this modem was unreliable in the presence of channel noise. This last feature prevented us from reaching a solid conclusion on the effect of data rate on communications.

4.2 The Carp-Penhold experiments

The short-link experiments were followed by various design enhancements, by the development of the full-duplex link operation and by the development of the network and transport functions. The correctness of the implementation of the networking functions was demonstrated in a network emulation which took place in summer 1985. This was followed by the adaptation of the system design to the HF communications environments at Carp and Penhold.

The long-link experiments took place from November 1985 to February 1986 between Carp (near Ottawa) and Penhold (Alberta). The same two basic experiments conducted over the short link were repeated over the long link. As before, the systems relied strictly upon their adaptiveness and ARQ mechanism to provide error-free user data.

The experimental configuration for the long-link experiments is shown on Figure 4.4. Control of the entire configuration was done via the system console at the control

centre. Remote receive and transmit control units were required to control HF modems and radio equipment under the direction of the HF data terminal. More modern radio equipment would alleviate the need for such remote units.

Another important characteristic of this configuration is the placement of the HF modems at the transmitter and receiver sites. Communication to the transmit/receive sites is done over DND landlines. In Penhold, approximately five and ten miles of underground twisted pair cables link these sites to the control centre. Because of the unknown quality of these cable pairs and their unknown variations in quality with soil conditions (e.g. frost, water, etc.), the decision was made to remote the HF modems to the transmitter and receiver sites. This safe approach was made at the cost of reducing system throughput by 50% owing to the delays introduced by digital transmissions over 4.8 kbps landlines.

The length of the frame synchronization-detection bit-pattern was increased from 16 bits for the short-link tests to 24 bits for the long-link experiments. This is the maximum length permissible by the enhanced version of the frame detector. The 24-bit pattern, although better than a 16-bit pattern, is still too weak. In a separate report currently being written, curves are produced showing the optimum pattern length as a function of the main parameters. There it is shown that the pattern length should be at least 31 bits for reasonable BER and data-length values.

The main operational and link parameters for this experiment were:

- 2842-kilometer link
- full-duplex, 2400-bps link operation
- forward error correction applied to the frame header only
- 5 frequencies from 7.9 - 19.2 MHz, in each direction
- horizontally polarized, log-periodic antenna
- less than 400 watts average power (typically 200 watts)
- 16-tone Kineplex-type HF modems (~ 20 watts/tone)
- solar cycle nearing sunspot minimum.

The experimental data gathering process at Carp and the throughput experiment were severely hampered by unreliable and malfunctioning HF receivers at Carp. It took three receivers and nearly two months to solve a subtle bit shift introduced in the data by offset reference oscillators in those receivers. Coincidentally, it had happened that the two receivers used in the laboratory tests in preparation for this experiment and initially used at Carp and Penhold, were good receivers. To carry through the last three weeks of experiments and to be able to demonstrate the system, a "fix" to this problem was found and consisted in providing the receiver with a reference frequency approximately 15 Hz below 10 MHz.

4.2.1 The results

For the three-month duration of the Carp-Penhold experiment, the channel-averaged daytime BER values, corrected for missed frame detections, were approximately 10^{-1} at Carp and 2×10^{-2} at Penhold. The average daytime BER values for the best (selected) channel, also corrected for missed frame detections, were 4×10^{-2} at Carp and 4×10^{-3} at Penhold, over the same period. The differences between those results are primarily due to the Carp receiver problems described previously; a secondary factor is the higher background noise level at Carp.

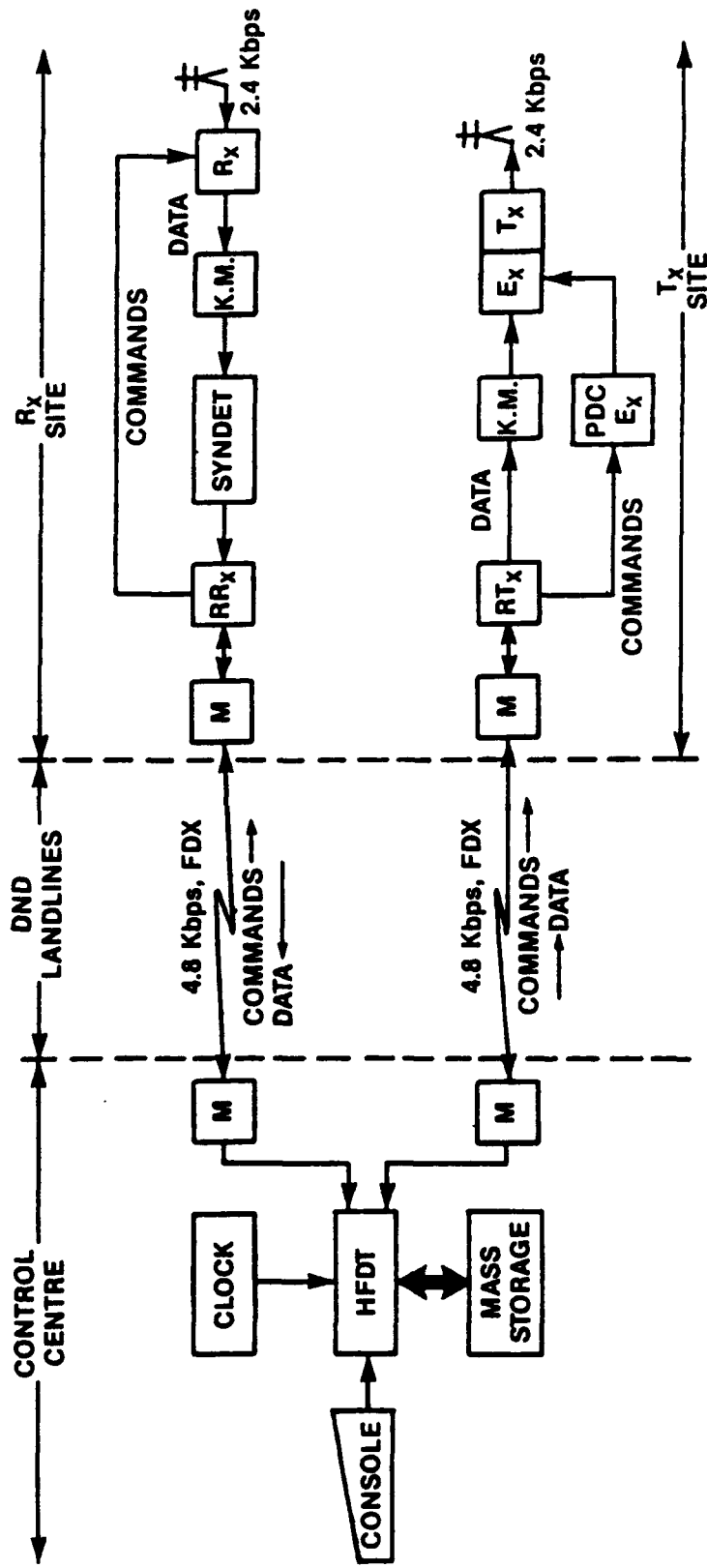

- M: LANDLINE SYNCHRONOUS MODEM
 - K.M.: HF KINEPLEX MODEM
 - RRx: REMOTE RECEIVE UNIT
 - RTx: REMOTE TRANSMIT UNIT
 - HFDT: HF DATA TERMINAL
 - SYNDET: SYNCHRONIZATION DETECTION CORRELATOR
-
- Ex: EXCITER
 - Rx: RECEIVER
 - Tx: TRANSMITTER
 - PDC Ex: PROGRAMMABLE DEVICE CONTROLLER FOR EXCITER

EXPERIMENTAL CONFIGURATION

Figure 4.4: THE CARP-PENHOLD EXPERIMENTAL CONFIGURATION

Nighttime propagation was generally not possible (see Figures 4.5 to 4.9) with the range of frequencies used. Channels in the 4-6 MHz range would have been required for nighttime communications. The experimental period included two major events, a broken sun filament and a severe geomagnetic storm, which resulted in HF radio blackout. The Carp-Penhold link (as well as other strategic HF links in Canada) lost connectivity for roughly two days in each case. Had the systems been using more power, there would still have been a loss of connectivity between Carp and Penhold although probably for a shorter period of time. An interesting observation was made during those events and is described below.

The main daytime results from the Carp-Penhold experiment were that:

- more than 90% of the time, a communication channel was available at 2400 bps (using little power);
- the typical daily average, error-free user throughput, in each direction, ranged from 100-300 bps (it would have been doubled that if the HF modems were located at the control centres);
- instances were found, associated with solar or geomagnetic events, in which Carp - Penhold communications were impractical, but shorter links (e.g. Carp-Shilo, Penhold-Shilo) recovered rather quickly and would have been utilizable;
- Carp-Penhold is an easy HF shot. The main difficulty in the first month of experiments was interference from other users. The HF data terminal making use of all its available channels, at least at channel-evaluation time, quickly solved this problem.

Figures 4.5 to 4.9 show the percentage of the time, as a function of Ottawa local time over the three-month interval, that a given channel was available. These figures show that, as expected, as the frequency is increased, the daily time-window of possible propagation decreases and the overall quality of the channel increases. Among the many conclusions that can be drawn from these figures, the main result to extract is that no individual frequencies were available more than approximately 50% of the time.

Figure 4.10 shows the same type of curve when the best channel, out of the five available frequencies, is selected. The percentage of availability then jumps from 50 to 90%. This is achieved through channel evaluation based on a simple error-counting RTCE technique. The result also serves to show that a primary mechanism to improve HF communications is real-time channel evaluation (an adaptive technique).

The period over which throughput data could have been obtained was reduced by two weeks of system tuning, nearly two months of Carp receiver problems and two weeks of system demonstrations. During the period when throughput data was gathered, the typical error-free user throughput ranged from 100-300 bps. More extensive throughput data would have probably shown a 0-400 bps range in throughput with a typical value around 200-250 bps. These values can be doubled by locating the HF modems at the control centres and thus eliminating the landline fixed-delays.

The likely gain in routing information in an HF network was recognized during the HF radio blackout events. At these times, all HF links were inoperational. However, short-to-medium (< 1000 km) range links recovered nearly one day sooner than longer links. Although it was only a partial recovery, i.e. link quality was mediocre, it would have been possible to achieve connectivity over the longer link by routing the information over shorter links (e.g. Carp-Shilo-Penhold).

The results presented above were achieved with low power, no forward error correction, a weak frame detector and an elementary RTCE technique for channel evaluation/selection. The connectivity obtained with this adaptive system is superior to that of strategic links using a lower data rate (75 bps) and more power (1 kW). The error-free throughput achieved with this adaptive system, even with no forward error correction, exceeds that of existing strategic HF communication systems by at least an order of magnitude. The operation of the system is automatic rather than man-intensive.

The data analysis process is still going on and other interesting results will come out. These results will appear in future technical reports.

4.3 Discussion

The results from on-air tests of the HF data terminal indicate that one can find a high-speed (2400-bps) HF communication channel at least 90% of the time in the sub-auroral region. Although the tests were done at near sunspot minimum, the long-link experiments were performed during the winter when HF communications are more difficult.

The adaptivity built into the link protocol and the physical-level channel evaluation/selection mechanism are able to provide better connectivity and throughput than in existing HF systems using lower signalling rates, higher power levels and error correction schemes. The improvement in error-free throughput provided by the HF data terminal is at least an order of magnitude beyond that of existing systems.

Experimental evidence has been found showing increased connectivity, and therefore survivability, provided by adaptive routing of information in an HF network. This result is supported by similar findings by BR Communications in tests over polar cap circuits [14]. BR found the existence of good north-south routes (at latitudes of approximately 62° and 37°) at times when polar-cap east-west routes were non-existent.

Although very encouraging, the experimental results of this prototype version of the HF data terminal could have been better if a more robust frame-detection pattern, better radio equipment and better HF modems had been used. In addition to the receiver problems, excitors had different tuning times on some frequencies and this resulted in missed frame detections on those channels. The HF modems had an unreliable carrier detect signal and typically consumed 75% of the time available for each transmission. The fixed delays reduce the effectiveness of the data terminal (i.e. decrease its throughput) by reducing the frequency of packet transmissions.

The experimental results demonstrate the validity of the adaptive-system approach as a means to improve HF communications connectivity, speed, reliability and survivability. This approach shows great potential and is likely to result in a new generation of HF communication systems.

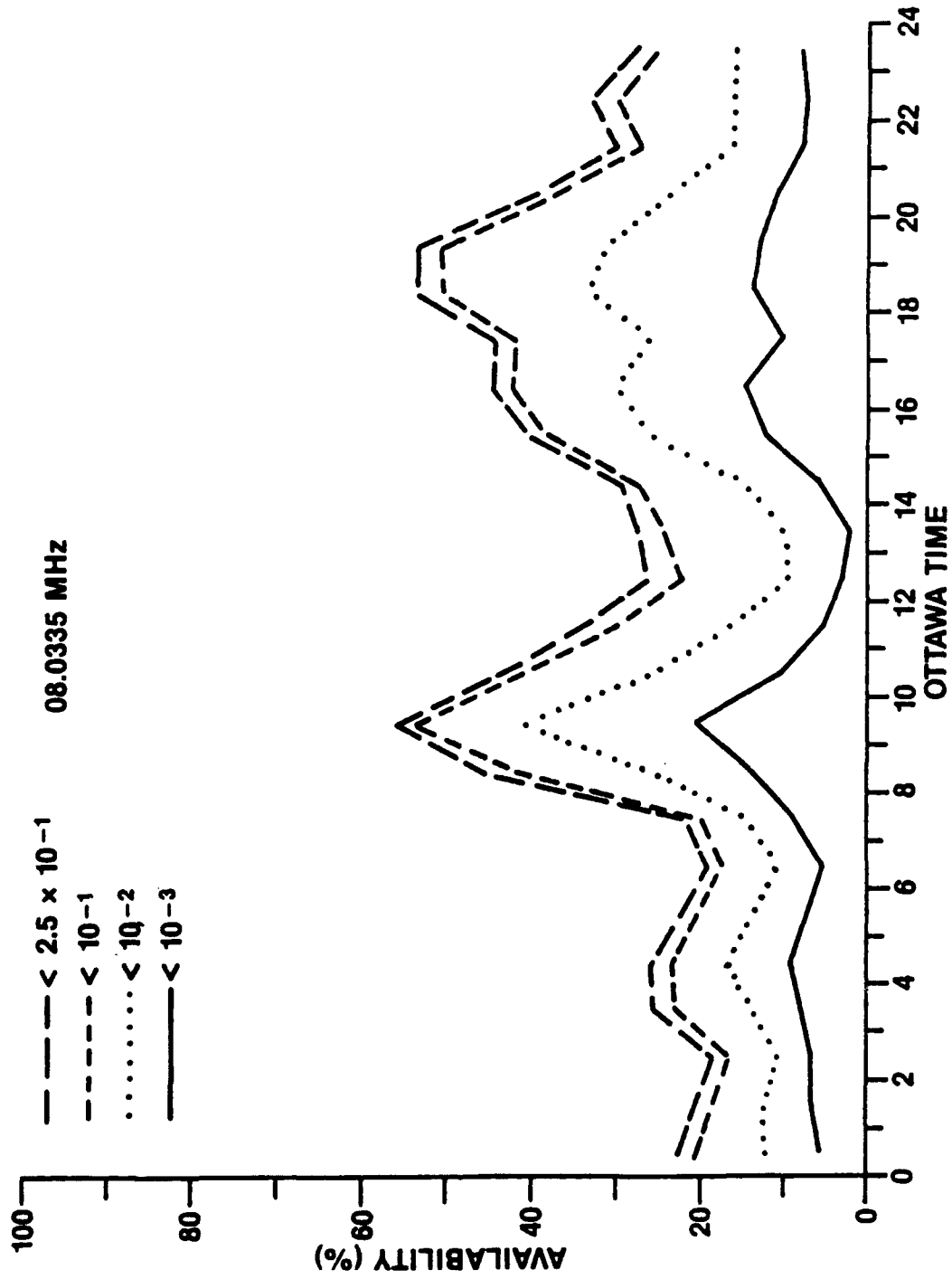

Figure 4.5: THE CARP-PENHOLD EXPERIMENT
 - CHANNEL 1 AVAILABILITY (PENHOLD)

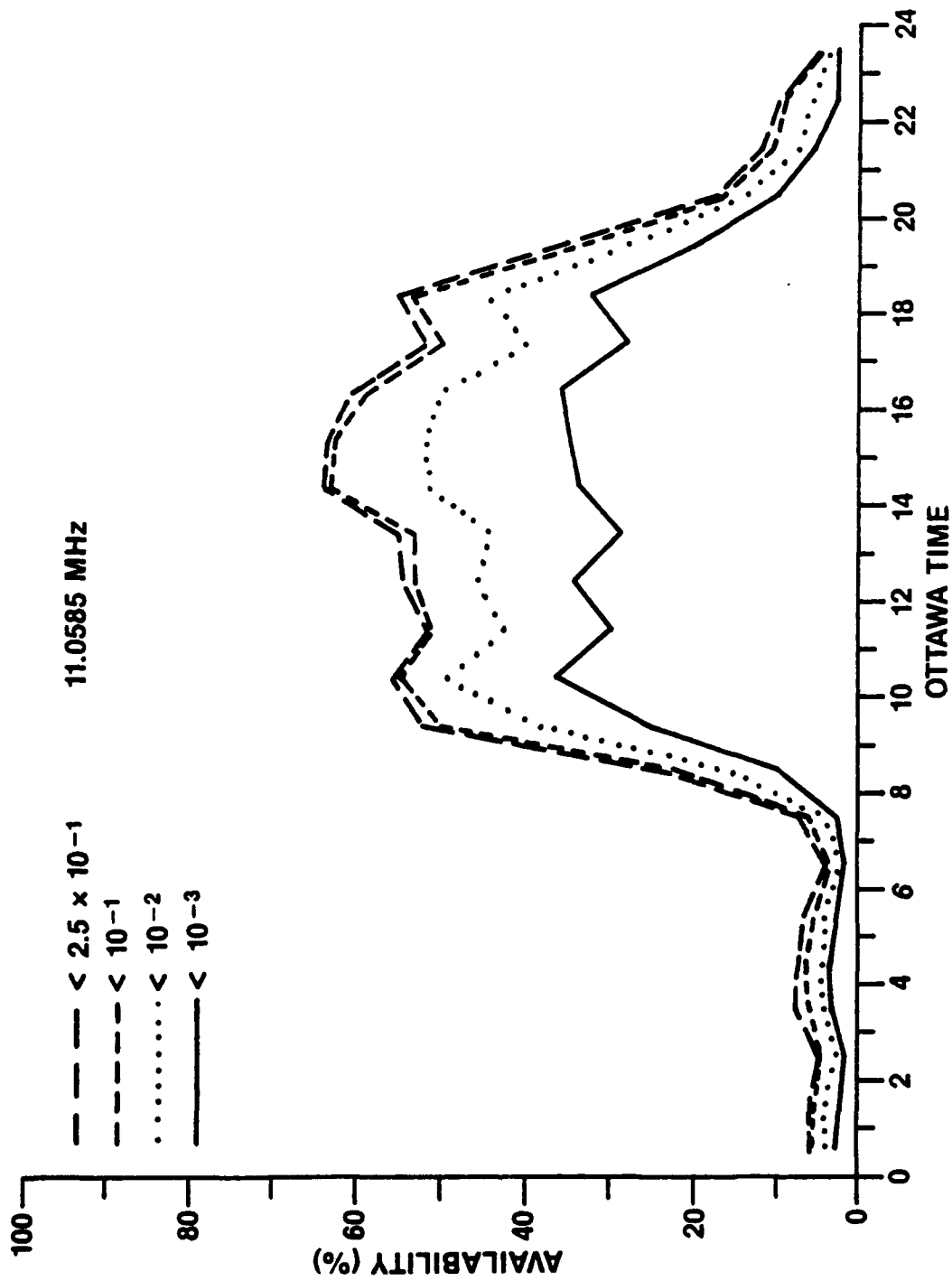

Figure 4.6: THE CARP-PENHOLD EXPERIMENT
 - CHANNEL 2 AVAILABILITY (PENHOLD)

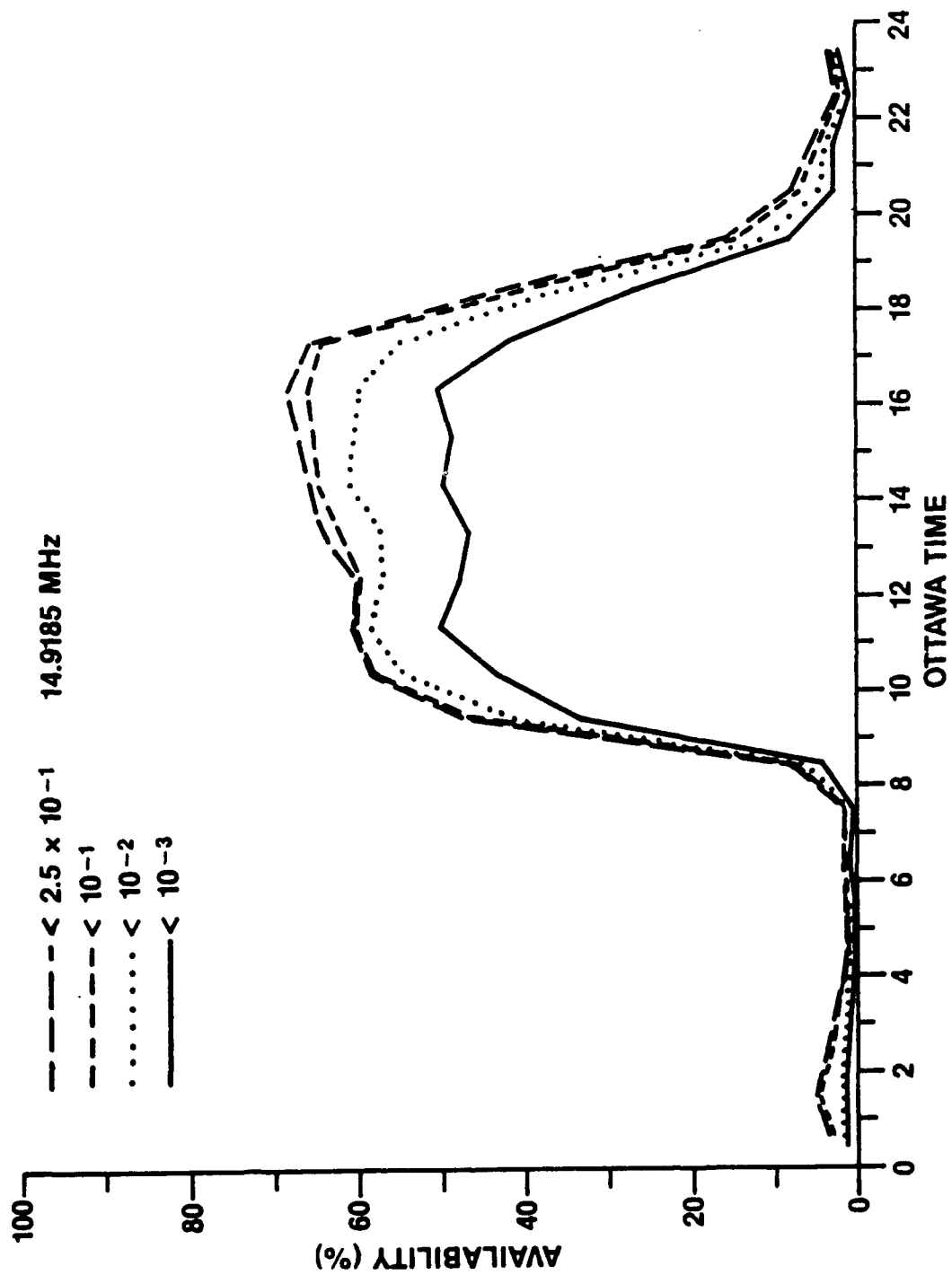

Figure 4.7: THE CARP-PENHOLD EXPERIMENT
 - CHANNEL 3 AVAILABILITY (PENHOLD)

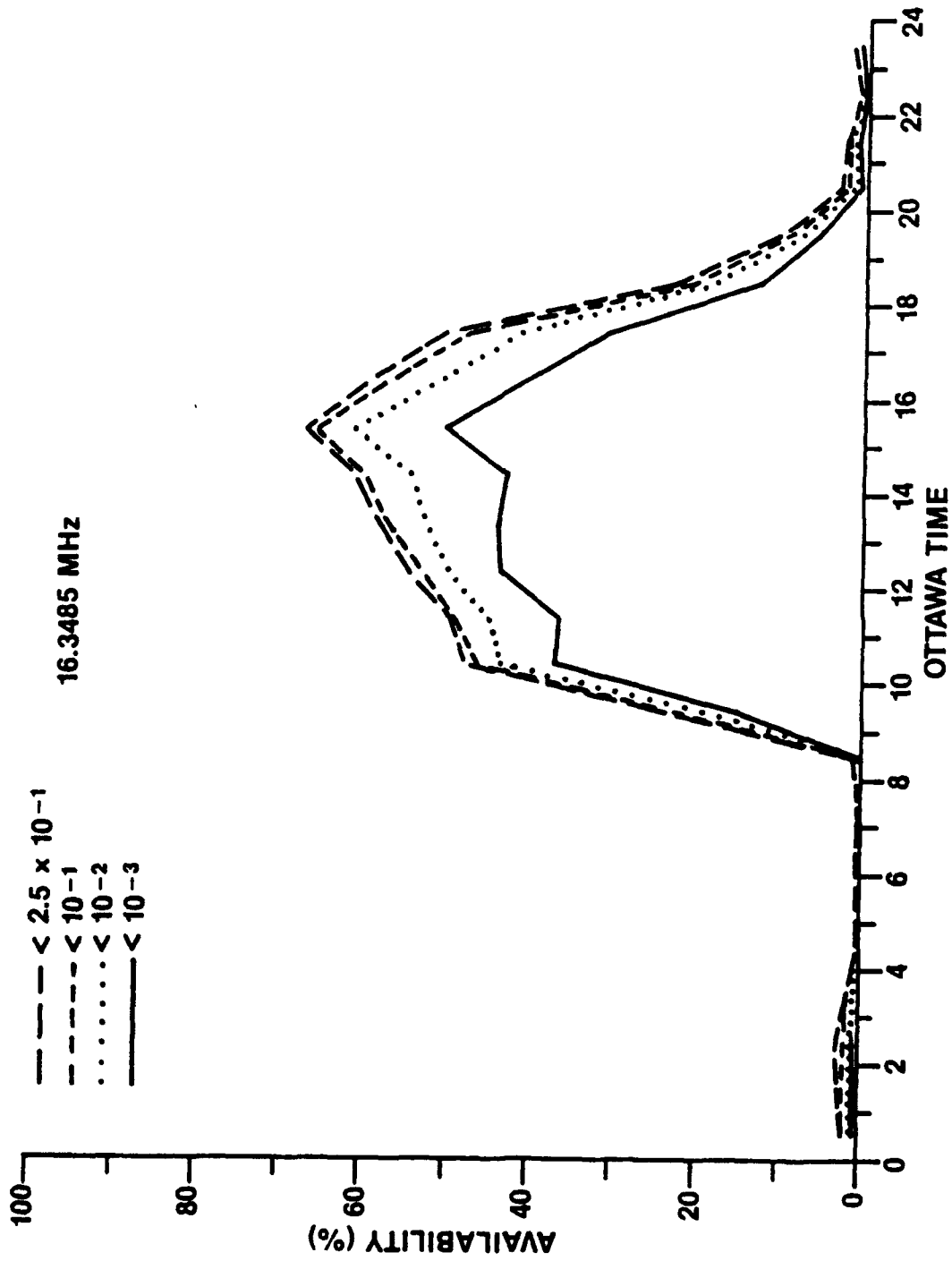

Figure 4.8: THE CARP-PENHOLD EXPERIMENT
 - CHANNEL 4 AVAILABILITY (PENHOLD)

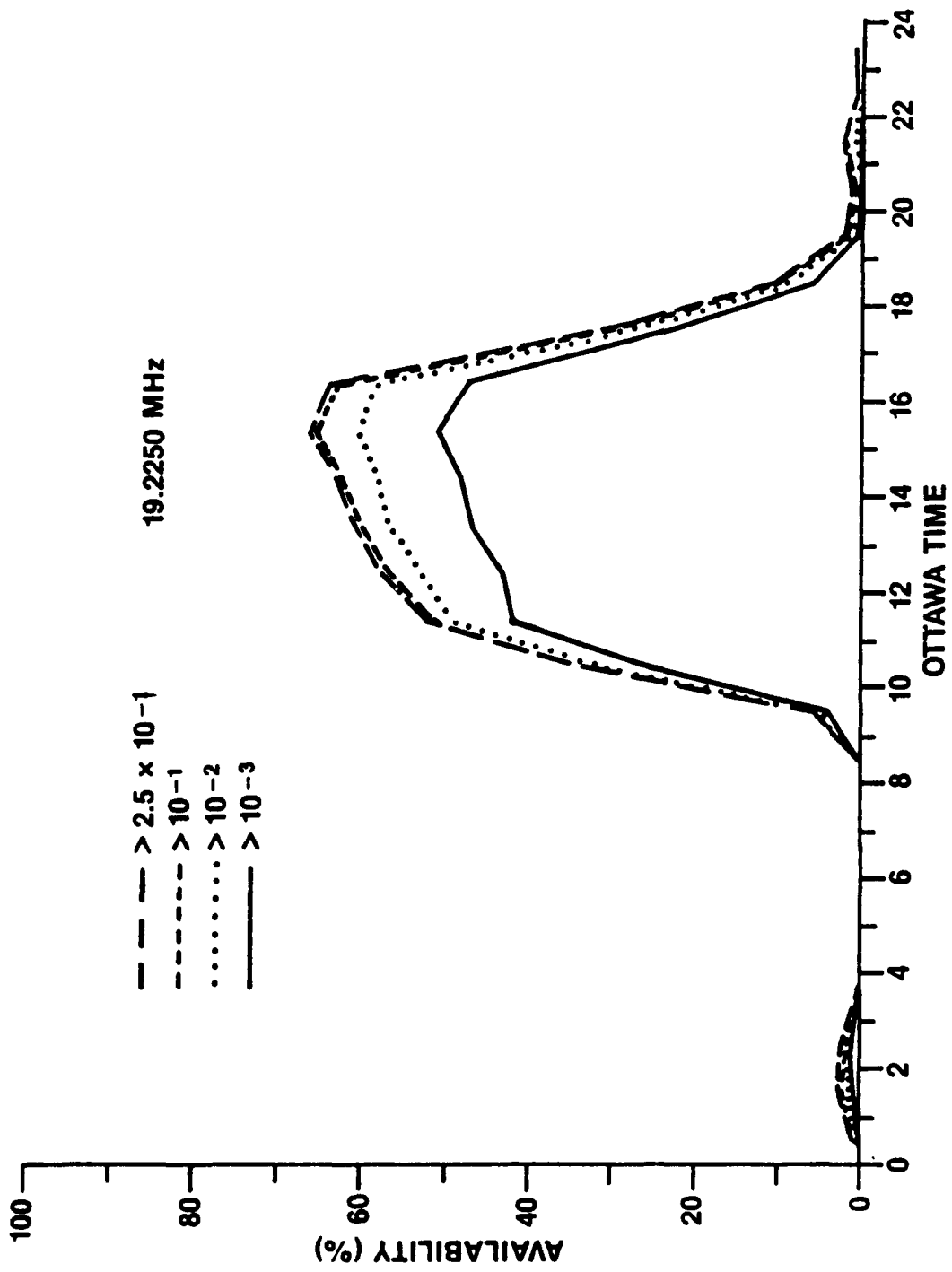

Figure 4.9: THE CARP-PENHOLD EXPERIMENT
 - CHANNEL 5 AVAILABILITY (PENHOLD)

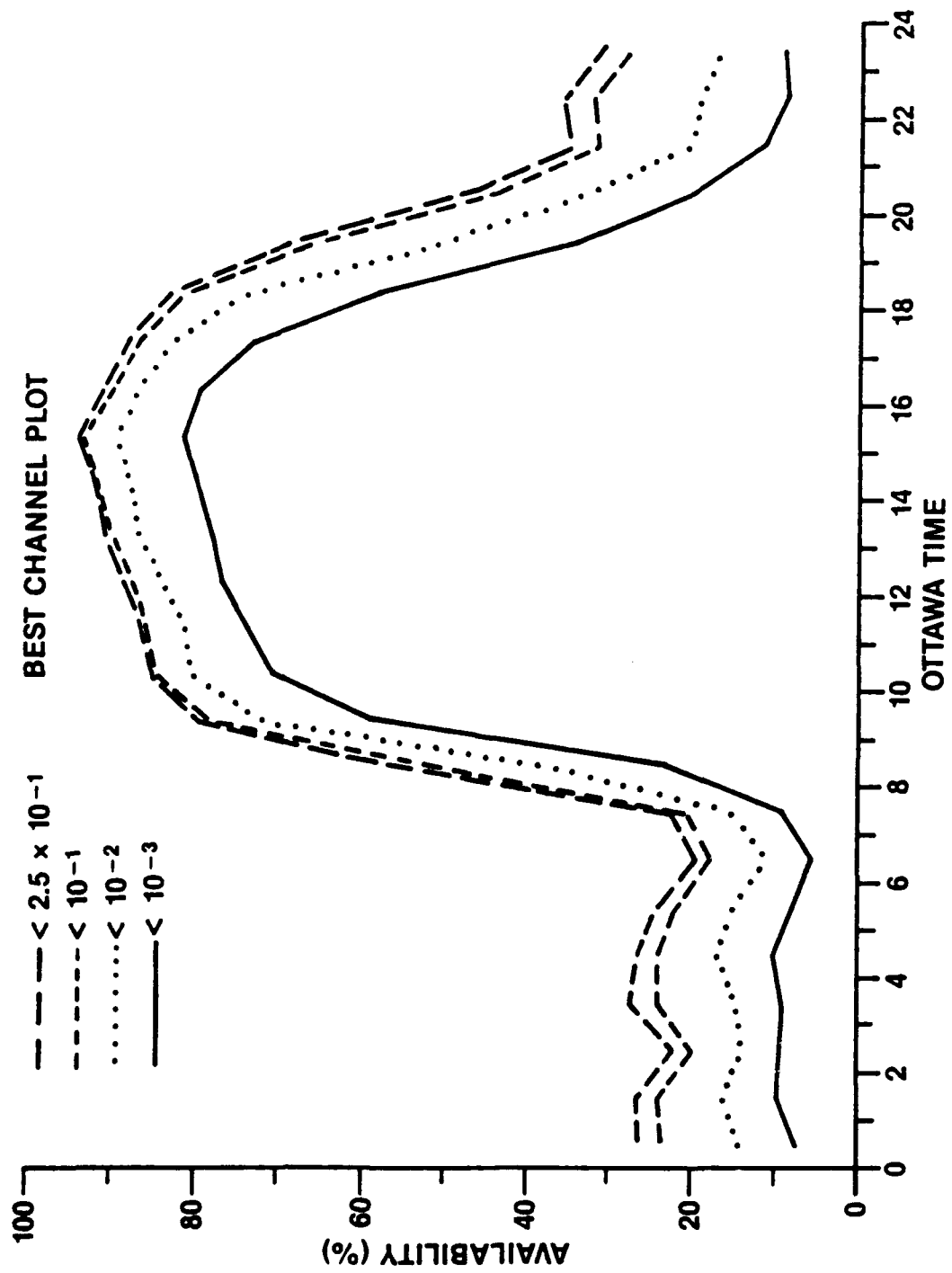

Figure 4.10: THE CARP-PENHOLD EXPERIMENT - AVAILABILITY OF BEST CHANNEL (PENHOLD)

5. FUTURE WORK

The experiments have served to demonstrate the validity of the new concepts implemented in the HF data terminal. Now that the basic concepts have been proven, the terminal can be further developed. New developments will be directed toward three general goals: to bring the terminal to the level of an operational unit, to enhance its performance and functionality, and to develop its interoperability functions with other networks.

A substantial portion of the development work toward any of these objectives will benefit the other goals as well. Rather than grouping future efforts as a function of the goal to which they apply, it is more convenient to categorize them into short-term and longer-term developments.

5.1 Short-term developments

Short-term efforts are directed to the goal of improving the system to a level where it can be put in the hands of DND operators for evaluation over an operational link, or where it can be tested over difficult links such as trans-auroral links. To this end, a number of modifications and additions will be done to the HF data terminal design. The main items are:

- migration of the current design to a multi-microprocessor design;
- integration of an adaptive HF serial modem into the HF data terminal communication system;
- development of the crypto interface;
- various system enhancements resulting from the Carp-Penhold experiments;
- inclusion of a robust frame-detection sequence.

The migration to a multi-microprocessor design is made necessary by added functionality in the terminal and by the desire to relieve the current main processor for additional link-monitoring purposes. The integration of the adaptive modem will add adaptiveness to the physical level and reduce the fixed delays experienced with other modems. The interface to a cryptographic device will provide a secure data mode, necessary for military applications.

Some of those design additions combined with various other enhancements resulting from the analysis of the experimental data, are expected to stabilize and to double, or better, the throughput of the system.

These short-term developments should take approximately six months to implement and will be paralleled by various improvements to the serial modem design such as continuous time and frequency tracking and implementation of an automatic gain control (AGC) algorithm.

5.2 Longer-term developments

The longer term includes activities envisaged to start six months from now. The longer-term developments will be finalized and prioritized after discussion with the sponsors. At the present time, it seems reasonable to direct longer-term efforts toward overall improvement of this new technology, network deployment and voice/data operation. The projected developments may include:

- addition of a digital voice mode;
- development of the link quality analysis functions of the modem;
- deployment of a network;
- development of the gateway functions to other networks;
- development of the man-machine interface;
- addition of other adaptive techniques (e.g. adaptive quality of service);
- addressing the spectrum management problem.

Most of these developments are self-explanatory. Further modem developments will make it more robust and will allow it to provide, dynamically, link-quality analysis data. The HF terminal will then be capable of dynamic, in-band, sophisticated real-time channel evaluation.

The digital voice mode will likely be provided by a vocoder incorporated in the terminal design. The vocoder would provide point-to-point voice service and, operating on its own sideband, would benefit from the channel evaluation/selection done by the terminal. With the addition of this mode, the terminal would then provide secure voice and data modes of operation.

The actual network deployment could be done in collaboration with DND or other organizations to keep costs down. A few foreign organizations and international bodies have already expressed interest in participating into such a venture. Network deployment can take place anytime after the short-term developments.

6. CONCLUSIONS

This project has used an adaptive-system approach to HF communications. It has made extensive use of adaptive techniques and of packet-switching techniques in particular. The vehicle implementing these techniques, the HF data terminal, not only includes RTCE techniques but is characterized by adaptivity throughout its design. It includes the functions for packet switching over HF and the management of a fully distributed and adaptive network. The terminal's adaptivity is implemented via a suite of robust, low-overhead, adaptive protocols that work even in low-bandwidth, error-prone environments.

A system based upon adaptive techniques improves significantly the connectivity, speed, throughput and reliability of HF communications. The experimental data has shown that high-speed (2400-bps) HF channels were available more than 90% of the time in the sub-auroral region. The HF data terminal, in its current version, already offers at least a one-order-of-magnitude improvement in error-free throughput over existing strategic HF communications systems.

The HF data terminal design, because it adapts to channel quality, is less vulnerable to errors and gracefully degrades its throughput under deteriorating channel conditions. Further, the experimental data suggest that the HF data terminal could efficiently be used at higher data rates over DND links. It would thus be worth conducting system tests at, for example, 4800 bps over CFCC links.

Packet switching over low-bandwidth, error-prone HF channels is feasible. A system using this technique improves the reliability and the survivability of HF communications. More experiments are needed to quantify this improvement.

Overall adaptive HF communication systems hold great promise now and for the future. They represent the next generation of HF communication systems. Further experimentation is required across trans-auroral and polar-cap circuits and in periods of high solar activity, to find out if such systems, in an adaptive network configuration, can meet all new HF military requirements. They are, it is believed, the most serious contender to meet these requirements

REFERENCES

1. J.S. BELROSE, Narrowband technologies suited to the transmission of voice and data for mobile radio systems. First Canadian Mobile Radio Communications User Conference, Ottawa, Ontario, May 1985.
2. J.S. BELROSE, On introduction of new technology for remote area radio communications. IEEE Wescanex '86 Conference on Transportation and Communications, Vancouver, B.C., June 1986.
3. E.E. STEVENS, The CHEC sounding system. In *Ionospheric Radio Communications* (Ed. K. Folksted), Plenum Press, New York, 1968.
4. S.M. CHOW, G.W. IRVINE, B.D. McLARNON and A.R. KAYE, Communications for small communities in developing countries. Pacific Telecommunications Conference, Honolulu, Hawaii, January 1981.
5. B.D. McLARNON, Real-time channel evaluation in an automatic HF radiotelephone system. Second Conf. on HF Communication Systems and Techniques, London, England, February 1982.
6. N.M. SERINKEN and S.M. CHOW, High-frequency data-message terminal. 15th Annual Off-Shore Technology Conference, Houston, Texas, pp. 415-420, May 1983.
7. N.M. SERINKEN and S.M. CHOW, Automatic HF radio message terminal system for sparsely populated communities. Pacific Telecommunications Council Seventh Annual Conference, Honolulu, Hawaii, 1985.
8. L.R. BODE, S.M. CHOW, N. SERINKEN, B. TEPPER and R. YAMANITO, Experimental evaluation of an HF data terminal in ship/shore mode. Department of Communications, CRC Report No. 1375, August 1984.
9. J.L. ROBINSON, An HF radio network architecture. IEEE International Conference on Communication, ICC 83, Boston, Mass, June 1983.
10. E. MARMARAS and W. BRUSH, Regency Net (RN): The communications system of the future. IEEE Military Communications Conference, MILCOM '83, 1983.
11. C.M. RUSH, H.F. propagation: what we know and what we need to know. IEE 2nd Conf. on Antennas and Propagation, Part 2 "Propagation", York, England, 1981.
12. C.C.I.R., Interim method for estimating sky wave field strength and transmission loss at frequencies between the approximate limits of 2 and 30 MHz. Report 252-2, ITU Geneva, 1970.
13. R. FLEURY and P. GOURVEZ, Influence des modèles d'ionosphère sur les calculs de propagation des ondes décimétriques. AGARD Conference Proceedings No. 263 "Special Topics in HF Propagation", AGARD-CP-263, 1979.

14. BR COMMUNICATIONS, HF propagation in the Arctic: High performance communication channels are available if you know where to look. Presentation at the AFCEA show, April 1986.
15. N.M. MASLIN, High data rate transmissions over h.f. links. The Radio and Electronic Engineer, Vol. 52, No. 2, February 1982.
16. E.V. THRANE, Problems in HF propagation. AGARD Lecture Series No. 127 "Modern HF Communications", AGARD-LS-127, 1983b.
17. AGARD-CP-382, Propagation effects on military systems in the high latitude region. AGARD Conference Proceedings No. 382, June 1985.
18. AGARD-CP-138, Non-linear effects in electromagnetic wave propagation. AGARD Conference Proceedings No. 138, 1974.
19. R.D. HUNSUCKER and H.F. BATES, Survey of polar and auroral region effects on HF propagation. Radio Science 4, 1969
20. R.D. HUNSUCKER, Morphology and phenomenology of the high latitude E- and F- regions. In Solar-Terrestrial Prediction Proceedings 2, Edited by R.F. Donnelly, 543 US Dept of Commerce, Boulder, USA, 1979.
21. P.A. BRADLEY, Propagation at medium and high frequencies, 1: Practical radio systems and modelling needs. AGARD Lecture Series No. 99, AGARD-LS-99, June 1979.

DOCUMENT CONTROL DATA

(Security classification of title, body of abstract and indexing annotation must be entered when the overall document is classified)

1. ORIGINATOR (the name and address of the organization preparing the document. Organizations for whom the document was prepared, e.g. Establishment sponsoring a contractor's report, or tasking agency, are entered in section 8.) Communications Research Centre P.O. Box 11490, Station H 3701 Carling Avenue Ottawa, ON K2H 8S2		2. SECURITY CLASSIFICATION (overall security classification of the document including special warning terms if applicable) UNCLASSIFIED	
3. TITLE (the complete document title as indicated on the title page. Its classification should be indicated by the appropriate abbreviation (S,C or U) in parentheses after the title.) AN ADAPTIVE, PACKET SWITCHED HF DATA TERMINAL - FUNCTIONAL OVERVIEW AND INITIAL PERFORMANCE (U)			
4. AUTHORS (Last name, first name, middle initial) NOURRY, GERARD R.			
5. DATE OF PUBLICATION (month and year of publication of document) July 1991	6a. NO. OF PAGES (total containing information. Include Annexes, Appendices, etc.) 50	6b. NO. OF REFS (total cited in document) 21	
7. DESCRIPTIVE NOTES (the category of the document, e.g. technical report, technical note or memorandum. If appropriate, enter the type of report, e.g. interim, progress, summary, annual or final. Give the inclusive dates when a specific reporting period is covered.) CRC TECHNICAL REPORT # 1423			
8. SPONSORING ACTIVITY (the name of the department project office or laboratory sponsoring the research and development. Include the address.) Defense Research Establishment Ottawa (DREO) Shirley's Bay, Ottawa K1A 0Z4			
9a. PROJECT OR GRANT NO. (if appropriate, the applicable research and development project or grant number under which the document was written. Please specify whether project or grant) 32B81 and 041LB		9b. CONTRACT NO. (if appropriate, the applicable number under which the document was written)	
10a. ORIGINATOR'S DOCUMENT NUMBER (the official document number by which the document is identified by the originating activity. This number must be unique to this document.) CRC Technical Note 1423		10b. OTHER DOCUMENT NOS. (Any other numbers which may be assigned this document either by the originator or by the sponsor)	
11. DOCUMENT AVAILABILITY (any limitations on further dissemination of the document, other than those imposed by security classification) <input checked="" type="checkbox"/> Unlimited distribution <input type="checkbox"/> Distribution limited to defence departments and defence contractors; further distribution only as approved <input type="checkbox"/> Distribution limited to defence departments and Canadian defence contractors; further distribution only as approved <input type="checkbox"/> Distribution limited to government departments and agencies; further distribution only as approved <input type="checkbox"/> Distribution limited to defence departments; further distribution only as approved <input type="checkbox"/> Other (please specify):			
12. DOCUMENT ANNOUNCEMENT (any limitation to the bibliographic announcement of this document. This will normally correspond to the Document Availability (11). However, where further distribution (beyond the audience specified in 11) is possible, a wider announcement audience may be selected.)			

13. ABSTRACT (a brief and factual summary of the document. It may also appear elsewhere in the body of the document itself. It is highly desirable that the abstract of classified documents be unclassified. Each paragraph of the abstract shall begin with an indication of the security classification of the information in the paragraph (unless the document itself is unclassified) represented as (S), (C), or (U). It is not necessary to include here abstracts in both official languages unless the text is bilingual).

ABSTRACT

This report describes the first-prototype version of an automatic, adaptive HF data terminal developed from 1983-1986. The terminal's main forms of adaptivity include a real-time channel evaluation and channel selection mechanism, an adaptive link protocol for channel optimization, and a fully distributed and adaptive routing algorithm for the selection of routes in an HF network. The terminal design is characterized by a suite of robust, low-overhead, adaptive protocols that work in low-bandwidth, error-prone and time-variant environments. The terminal's performance is illustrated with results from tests over short and long HF links carried out in Fall 84 and Winter 85-86.

14. KEYWORDS, DESCRIPTORS or IDENTIFIERS (technically meaningful terms or short phrases that characterize a document and could be helpful in cataloging the document. They should be selected so that no security classification is required. Identifiers, such as equipment model designation, trade name, military project code name, geographic location may also be included. If possible keywords should be selected from a published thesaurus. e.g. Thesaurus of Engineering and Scientific Terms (TEST) and that thesaurus-identified. If it is not possible to select indexing terms which are Unclassified, the classification of each should be indicated as with the title.)

HIGH FREQUENCY COMMUNICATIONS
ADAPTIVE HF COMMUNICATIONS
PACKET-SWITCHED HF COMMUNICATIONS
HF PACKET RADIO