

AD-A246 371



FINAL REPORT
FEBRUARY 1991

REPORT NO. EVT 33-90-1

OPERATION DESERT STORM

SOLAR RADIATION
SHIELDING MATERIALS FOR
AMMUNITION STORAGE

DTIC
ELECTE
FEB 21 1992
S D D

Distribution Unlimited

Handwritten marks: 'u' and a circled '1'



This document has been approved
for public release and sale; its
distribution is unlimited.

92-04319

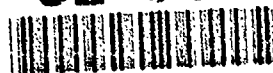

92 2 14 106

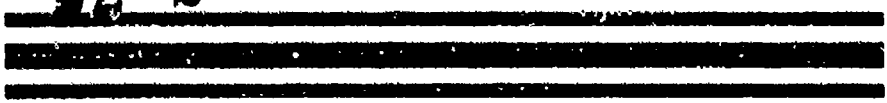

VALIDATION ENGINEERING DIVISION
SAVANNA, ILLINOIS 61074-9639

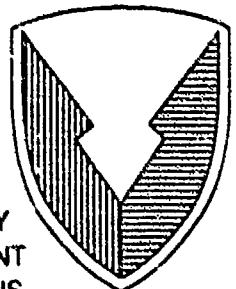

U.S. ARMY
ARMAMENT
MUNITIONS
CHEMICAL COMMAND
U.S. ARMY DEFENSE AMMUNITION
CENTER AND SCHOOL

AVAILABILITY NOTICE

A copy of this report is furnished each attendee on automatic distribution. Should additional copies be required, authority for reprinting may be obtained by written request from Director, U.S. Army Defense Ammunition Center and School, ATTN: SMCAC-DEV, Savanna, IL 61074-9639.

DISPOSITION INSTRUCTIONS

Destroy this report when no longer needed. Do not return.

* * *

Use of trade names in this report does not constitute an official endorsement.

* * *

The information contained herein will not be used for advertising purposes.

REPORT DOCUMENTATION PAGE

Form Approved
OMB No. 0704-0188

1a. REPORT SECURITY CLASSIFICATION UNCLASSIFIED		1b. RESTRICTIVE MARKINGS	
2a. SECURITY CLASSIFICATION AUTHORITY		3. DISTRIBUTION / AVAILABILITY OF REPORT UNLIMITED	
2b. DECLASSIFICATION / DOWNGRADING SCHEDULE			
4. PERFORMING ORGANIZATION REPORT NUMBER(S) EVT 33-90-1		5. MONITORING ORGANIZATION REPORT NUMBER(S)	
6a. NAME OF PERFORMING ORGANIZATION U.S. Army Defense Ammunition Center and School		6b. OFFICE SYMBOL (If applicable) SMCAC-DEV	7a. NAME OF MONITORING ORGANIZATION
6c. ADDRESS (City, State, and ZIP Code) ATTN: SMCAC-DEV Savanna, IL 61074-9639		7b. ADDRESS (City, State, and ZIP Code)	
8a. NAME OF FUNDING / SPONSORING ORGANIZATION		8b. OFFICE SYMBOL (If applicable)	9. PROCUREMENT INSTRUMENT IDENTIFICATION NUMBER
8c. ADDRESS (City, State, and ZIP Code)		10. SOURCE OF FUNDING NUMBERS	
		PROGRAM ELEMENT NO.	PROJECT NO.
		TASK NO.	WORK UNIT ACCESSION NO.
11. TITLE (Include Security Classification) Solar Radiation Shielding Materials for Ammunition Storage			
12. PERSONAL AUTHOR(S) William R. Meyer			
13a. TYPE OF REPORT Final	13b. TIME COVERED FROM _____ TO _____	14. DATE OF REPORT (Year, Month, Day) 1991 February	15. PAGE COUNT
16. SUPPLEMENTARY NOTATION			
17. COSATI CODES		18. SUBJECT TERMS (Continue on reverse if necessary and identify by block number)	
FIELD	GROUP		
19. ABSTRACT (Continue on reverse if necessary and identify by block number) The U.S. Army Defense Ammunition Center and School (USADACS), Validation Engineering Division (SMCAC-DEV), conducted engineering tests on thermal insulating materials which could be used to protect ammunition in Saudi Arabia (SA). This report contains the test results of several materials which provide excellent shielding of ammunition from direct solar radiation. → 8 / - /			
20. DISTRIBUTION / AVAILABILITY OF ABSTRACT <input checked="" type="checkbox"/> UNCLASSIFIED/UNLIMITED <input type="checkbox"/> SAME AS RPT. <input type="checkbox"/> DTIC USERS		21. ABSTRACT SECURITY CLASSIFICATION UNCLASSIFIED	
22a. NAME OF RESPONSIBLE INDIVIDUAL JEROME H. KROHN		22b. TELEPHONE (Include Area Code) 815-273-8929	22c. OFFICE SYMBOL SMCAC-DEV

U.S. ARMY DEFENSE AMMUNITION CENTER AND SCHOOL
VALIDATION ENGINEERING DIVISION
SAVANNA, IL 61074-9639

REPORT NO. EVT 33-90-1

OPERATION DESERT STORM

SOLAR RADIATION SHIELDING MATERIALS FOR
AMMUNITION STORAGE

TABLE OF CONTENTS

PART	PAGE NO.
1. INTRODUCTION	1-1
A. BACKGROUND.....	1-1
B. AUTHORITY	1-1
C. OBJECTIVE.....	1-1
2. TEST ATTENDEES.....	2-1
3. TEST PROCEDURES.....	3-1
4. TEST EQUIPMENT.....	4-1
5. TEST RESULTS.....	5-1
6. DISCUSSION.....	6-1
7. PHOTOGRAPHS	7-1
8. GRAPHS.....	8-1

PART 1

INTRODUCTION

A. BACKGROUND. Absorption of heat through high ambient temperatures and solar radiation has proven to have an adverse/detrimental effect on ammunition in open storage. As such, USADACS, during early deployment of ammunition to Saudi Arabia (SA), conducted screening tests on solar radiation materials that could be used to protect ammunition stored under desert conditions. As a result of this testing, several thermal insulating materials were identified that could be used as solar radiation protective covers in SA.

B. AUTHORITY. These tests were conducted in accordance with mission responsibilities delegated by the U.S. Army Armament, Munitions and Chemical Command (AMCCOM), Rock Island, IL.

C. OBJECTIVE. The objectives of this evaluation were to determine what effect direct solar radiation had on ammunition in open storage, in individual shipping containers, in pallets, and loaded Military Vans (MILVANS). Other objectives included the screening of synthetic materials to determine which were most suitable for thermal shields to protect the ammunition.

Accession For	
NTIS CRA&I	✓
DTIC TAB	10
Unannounced	10
Justification	
By	
Distribution /	
Availability Codes	
Dist	Avail and/or Special
A-1	

PART 2

OPERATION DESERT STORM

SOLAR RADIATION SHIELDING MATERIALS FOR
AMMUNITION STORAGE

TEST ATTENDEES

<u>NAME AND TELEPHONE NUMBER</u>	<u>ORGANIZATION</u>
William R. Meyer Test Engineer DSN 585-8090 Comm 815-273-8090	Director U.S. Army Defense Ammunition Center and School ATTN: SMCAC-DEV Savanna, IL 61074-9639
Quinn D. Hartman Test Engineer DSN 585-8992 Comm 815-273-8992	Director U.S. Army Defense Ammunition Center and School ATTN: SMCAC-DEV Savanna, IL 61074-9639
David V. Valant Electronics Technician DSN 585-8988 Comm 815-273-8988	Director U.S. Army Defense Ammunition Center and School ATTN: SMCAC-DEV Savanna, IL 61074-9639
Steven L. Von Thun Technical Illustrator DSN 585-8093 Comm 815-273-8093	Director U.S. Army Defense Ammunition Center and School ATTN: SMCAC-DEV Savanna, IL 61074-9639

PART 3

TEST PROCEDURES

A. THERMAL SHIELDING TESTS. A total of 15 thermal shielding materials were evaluated. Each material was tested with inertly-loaded 155mm propellant charge containers, with interior and exterior temperature probes placed at critical points. Temperature data were taken every 5 minutes for a period of not less than 24 hours per each test, including ambient and control (unprotected) temperature measurements. After testing, all materials were evaluated to determine which materials provided the greatest protection against solar radiation. Drawing no. 1 (see page 3-2) depicts the typical test setup used during these tests.

SOLAR RADIATION PROTECTIVE COVERING

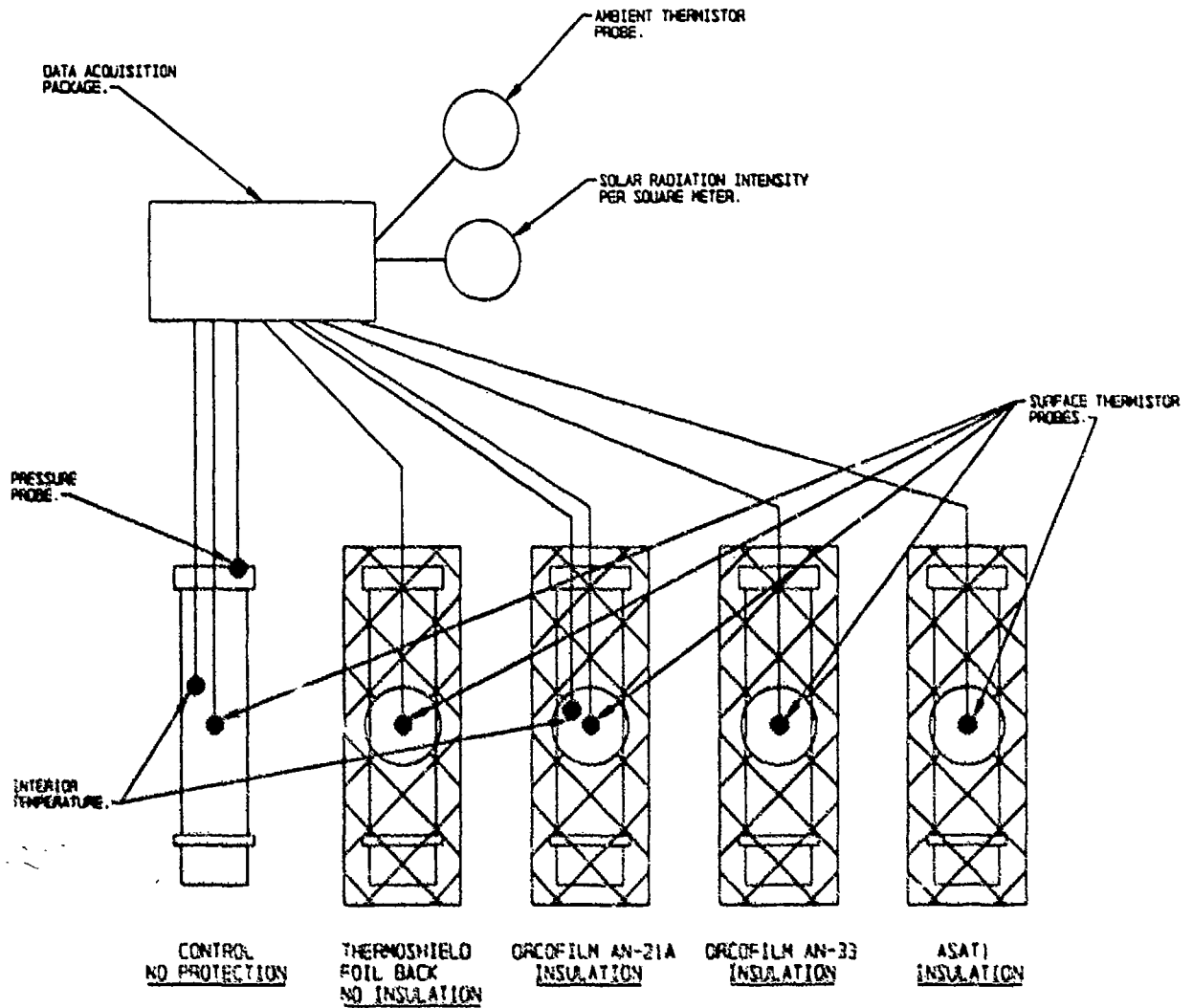

NOTES:

1. 155mm PROP CHARGES INERT FILL.

B. PALLET TESTING. Pallets containing inertly-loaded PA116 containers were instrumented with external probes both on top and between layers of the pallet. Instrumentation included at least one ambient temperature probe and a control pallet which had no protective covering. Test pallets were covered with different protective coverings both with and without air space between the covering. Additional tests were conducted with sandbag-covered pallets with no air space provided. All test pallets were compared to the control pallet to determine what level of protection was being afforded by the protective coverings. Drawing no. 2 (see page 3-4) depicts the typical test setup used during this series of tests.

SOLAR RADIATION PROTECTIVE COVERING

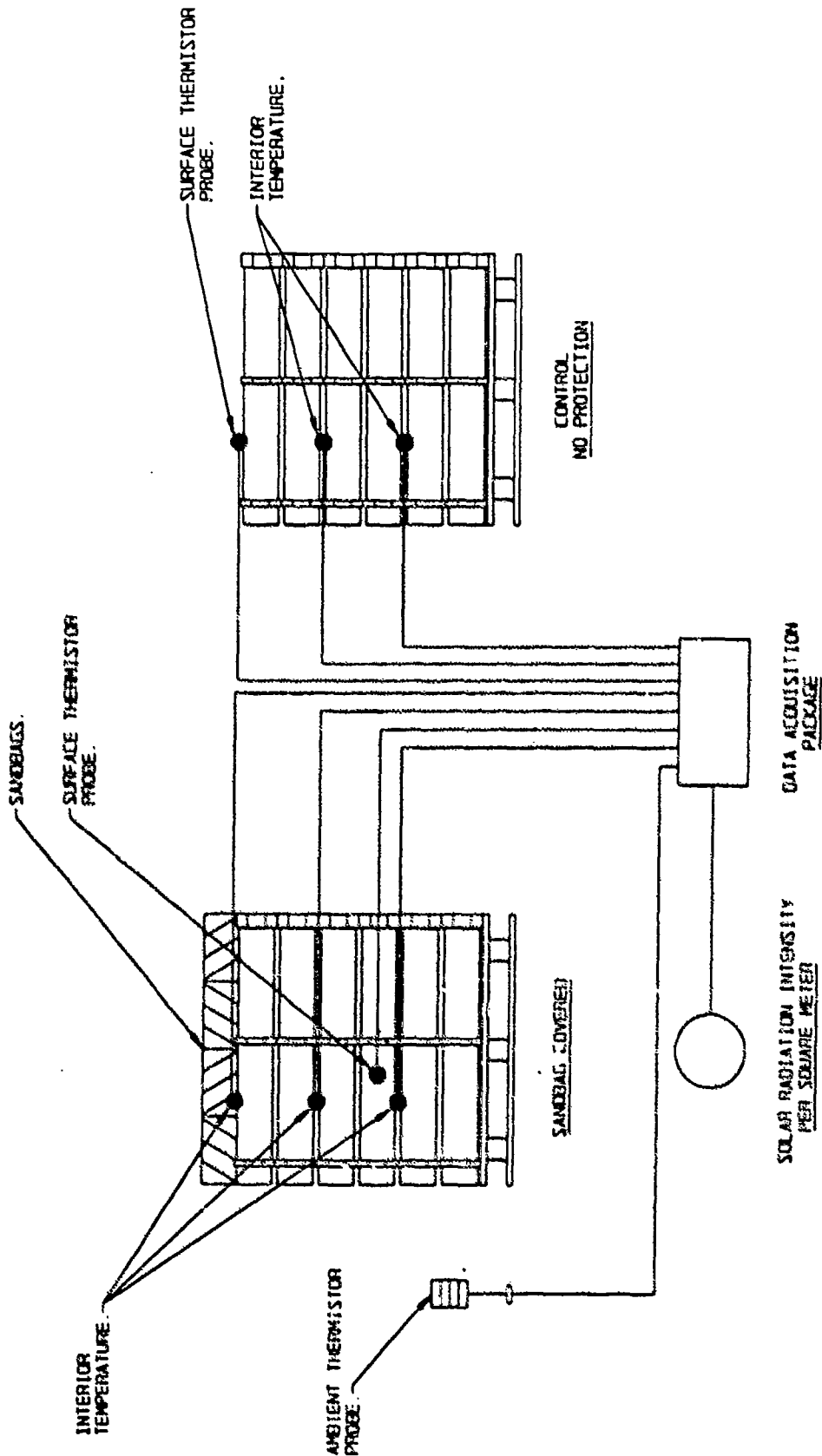

NOTES:

1. P4116 CONTAINERS INERT FILL SAND
2. P4116 CONTAINERS UNITIZED 6 HIGH X 5 WIDE

C. MILVAN TESTING. A MILVAN containing inertly-loaded 105mm boxed ammunition was instrumented at the following locations:

- (1) On the outside of the roof of the MILVAN.
- (2) At the top of the MILVAN load.
- (3) At the center of the load.
- (4) Ambient temperatures at the test site.

Tests were conducted with the MILVAN doors open and closed. Test data were taken every 5 minutes for a period of not less than 24 hours. Interior, roof, and ambient temperatures were compared to determine internal temperature gain within the MILVAN. Drawing no. 3 (see page 3-6) depicts the typical test setup during MILVAN testing.

SOLAR RADIATION PROTECTIVE COVERING

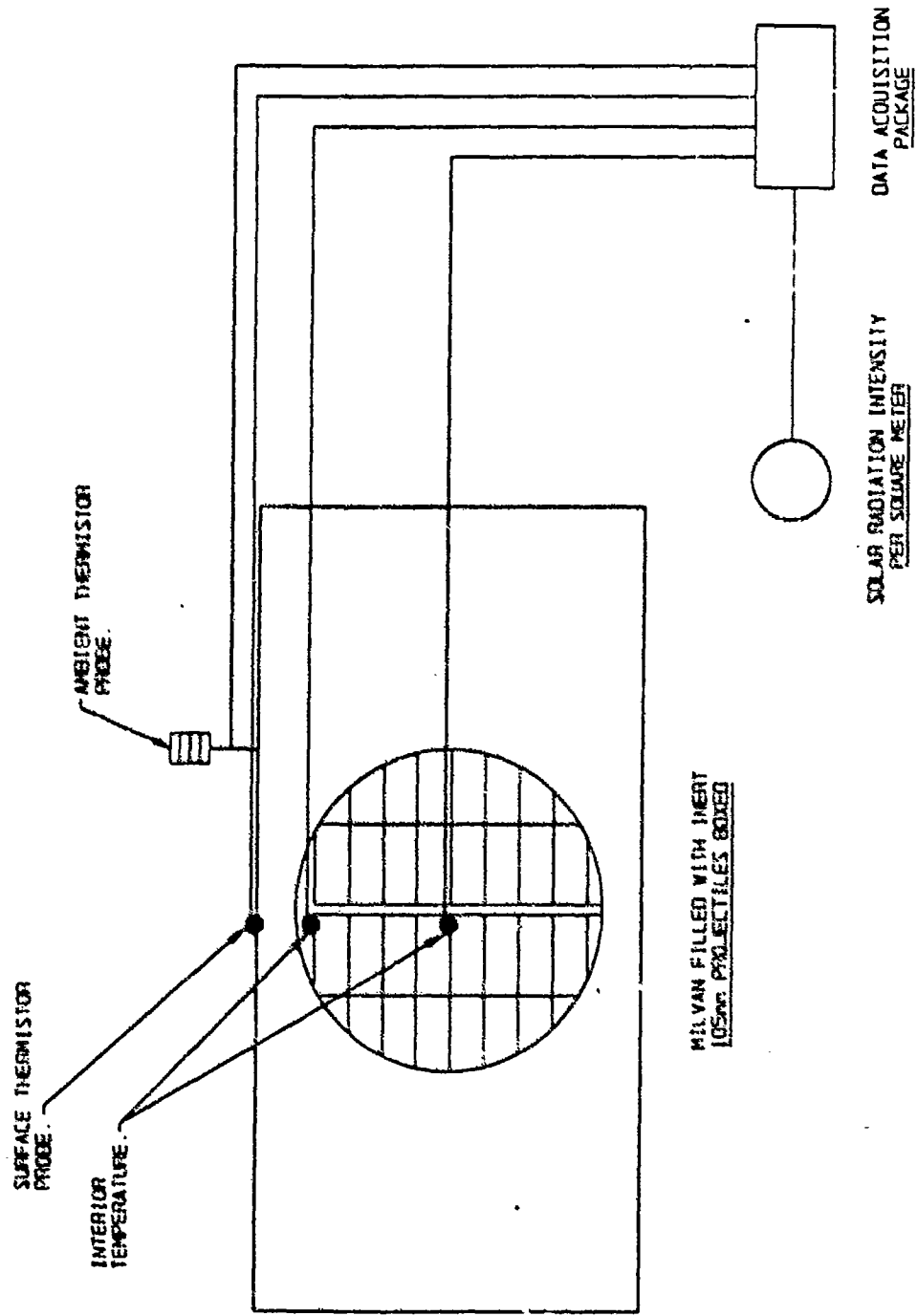

PART 4

TEST EQUIPMENT

1. TEST CONTAINERS.

- a. Item: 155mm Hol. M119 Containers (OD color)
- b. FSN: 1320-143-6847-D533
- c. Type: SPM109 A1
- d. Weight: 41 pounds
- e. Cube: 1.7 cubic feet

2. TEST PALLET.

- a. Item: PA116 Containers W/Metal Pallets (OD color)
- b. Drawing: AC200000501
- c. Width: 40 inches
- d. Length: 44-1/2 inches
- e. Height: 52-5/8 inches
- f. Weight: 2,400 pounds

3. DATA RECORDER.

- a. Manufacturer: Omega Engineering
- b. Model No.: OM-220
- c. Channels: 8
- d. Memory: 32,000 Reading

PART 5

TEST RESULTS

A. MATERIAL SCREENING TESTS:

1. Tests were conducted 17 August - 26 September 1990 on 15 thermal shielding materials. To assist in evaluation of these materials, test data has been broken down into the following four categories:

- (a) Exterior temperature of control samples.
- (b) Interior temperature of control samples.
- (c) Exterior temperature of protected (shielded) samples.
- (d) Interior temperature of protected (shielded) samples.

This approach will help assess temperature buildup on both unprotected and protected containers.

2. Table no. 1 depicts the effects of solar radiation on unprotected 155mm propellant charge containers exposed directly to sunlight. During this test, surface temperature probes were attached to the exterior skin of each container. During the nine tests, ambient temperature averaged 89 degrees Fahrenheit while the average skin temperature of unprotected containers averaged 133.2 degrees Fahrenheit, or 44.2 degrees Fahrenheit above ambient.

155mm Propellant Charge Container
Exterior Skin Temperatures
No Exterior Protection

Table 1

<u>Test Number</u>	<u>Test Date</u>	<u>Ambient Temperature</u>	<u>Skin Temperature</u>	<u>Temperature Differential</u>
1	8-23	85	120	+35
2	9-25	85	132	+47
3	8-30	85	135	+50
4	9-26	85	140	+56
5	8-24	89	125	+36
6	8-29	90	140	+50
7	8-27	93	140	+47
8	9-4	94	132	+38
9	8-17	95	135	+40

3. Of notable interest during this series of tests was the effect of solar radiation on test samples when ambient temperature remained constant. Note: test numbers 1-4 had an ambient temperature of 85 degrees Fahrenheit; however, surface skin temperatures ranged from 120 degrees to 140 degrees Fahrenheit. This 41 percent to 64 percent elevation over ambient was due to the intensity of the sun, duration of the solar radiation, cloud cover, particulate in the air, wind, etc. This is significant when determining adverse effects of solar radiation in SA; i.e., ambient temperatures of 120 degrees Fahrenheit could result in surface skin temperatures as high as 180 degrees Fahrenheit or higher.

4. A second series of tests conducted used internal proximity probes within the 155mm propellant charge metal containers to determine what thermal conductivity was taking place inside the containers. These probes were in direct contact with the inert propellant bags. During

this test average ambient temperature was 88.3 degrees Fahrenheit, while the average interior temperature was 119.0 degrees Fahrenheit, or a temperature elevation of 30.7 degrees Fahrenheit (35 percent increase). Thermal lag during this test was approximately 14 degrees lower than the outside skin temperature.

155mm Propellant Charge Metal Container
Interior Propellant Charge Temperatures
No Exterior Protection

Table 2

<u>Test Number</u>	<u>Test Date</u>	<u>Ambient Temperature</u>	<u>Skin Temperature</u>	<u>Temperature Differential</u>
1	8-23	85	105	+20
2	8-30	85	118	+33
3	9-25	85	120	+35
4	9-25	85	128	+43
5	8-24	89	110	+21
6	8-29	90	124	+34
7	8-27	93	125	+32
8	9-4	94	122	+28
9	9-26	84	129	+45

5. As noted above, internal air temperatures varied within the sealed containers while ambient temperature remained constant (as shown in tests 1 - 4, ambient temperature was 85 degrees). While interior temperatures ranged from 105 degrees Fahrenheit to 128 degrees Fahrenheit, this suggests that with ambient temperature approaching 120 degrees Fahrenheit in SA, internal temperatures could reach in excess of 165 degrees Fahrenheit.

6. Other tests were conducted on materials used for thermal shielding. All shielding materials were placed directly in contact with the surface of the container (with no air space or 3

1/2- inches above as noted), this provided a "worst case" condition for materials being tested. Due to different ambient temperatures during these tests, effectiveness of materials was determined by the temperature rise over ambient temperature. For example, shielding materials that allowed for very little temperature elevation over ambient were determined to be most effective. Table 3 summarizes the test results.

Single 155mm Propellant Charge Metal Container
Outside Skin Temperatures
Exterior Protection

Table 3

Sample Type	Test Date	Ambient Temperature	Exterior Temperature	Temperature Differential
R13 Insulated White/Foil	8-17	89	88	-1
White/Foil W/O Insulation	8-17	89	95	+6
Camouflage W/F 3.5" Space	8-24	89	95	+6
Ludlow	9-4	94	100	+6
Chase Ext	9-4	94	100	+6
ASATI	8-29	92	99	+7
AN19	9-25	85	92	+7
AN35-40	9-25	85	93	+8
12589 Ext	8-30	85	95	+10
Canvas (3.5" space ext)	8-24	91	103	+12
Champion	9-26	85	99	+14
ER-3834	8-29	90	105	+15
Camouflage White/Foil	8-23	85	105	+20
Canvas (no space ext)	8-23	85	112	+27
DeWitt Ext	9-26	85	120	+35

7. As noted above, canvas with no air space was one of the poorest solar radiation materials (this would hold true for any dark, opaque materials). When the canvas was elevated

(3.5 inches) above the container, a marked improvement in the cooling effect was noted (+12 versus +27 temperature differential). Of the 15 materials tested, 8 materials were successful at maintaining temperature elevations of less than 10 degrees Fahrenheit above ambient, with all being classified as satisfactory thermal shielding materials. Eight materials appeared to be equivalent with the exception of a product containing 3.5 inches of insulation, (Ref: R13 Insulated White/Foil). Although this material was far superior at keeping temperatures closer to ambient, it appeared to be not practical for field applications.

8. During additional tests, interior temperature probes were placed within 120mm propellant charge metal containers to determine what heat was thermally conducted through the skin of the container.

120mm Propellant Charge Metal Container
Interior Temperatures
Exterior Protection

Table 4

Sample Type	Test Date	Ambient Temperature	Interior Temperature	Temperature Differential
Canvas (3.5" Space Int)	8-27	93	105	+12
DeWitt Int	9-25	85	100	+15
DeWitt Int	9-26	85	109	+24
Chase Int	9-4	94	98	+4

9. As noted in Table 4, temperature elevations within the containers ranged from 4 degrees Fahrenheit to 24 degrees Fahrenheit above ambient, and dependent on the type of cover being used. As was apparent during this test, the interior temperature is not directly related to the ambient temperature, but indirectly related to the amount and duration of solar exposure. For example, on two separate test dates ambient temperatures were at 85 degrees, while the interior

temperatures of DeWitt Company samples ranged from 15 degrees Fahrenheit to 24 degrees Fahrenheit above ambient.

B. PALLET TESTS:

1. During this test, temperature probes were placed on top as well as on intermittent layers within the pallets (second and fourth layers). Two pallets were used during this test: control pallet with no protection, and a covered (protected) pallet with 18 inches of air space.

Pallet Solar Radiation Test
Exterior Skin Temperatures
Canvas Covered, 18-Inches Above

Table 5

Test Number	Test Date	Ambient Temperature	Control Pallet	Test Pallet (Covered)	Temperature Differential
-----Top Containers-----					
1	9-5	90	130	105	25
2	9-6	91	125	96	29
3	9-10	82	125	92	33
4	9-11	85	130	96	34
5	9-12	85	122	92	30
-----Middle Layers-----					
1	9-5	90	93	93	0
2	9-6	91	95	95	0
3	9-10	82	84	82	2
4	9-11	85	86	85	1
5	9-12	85	86	84	2

2. During the five tests conducted, the average temperature rise of the unprotected container was 39.6 degrees over ambient, or a 45.6 percent temperature increase on the exposed top container layer. The protected (canvas-covered) pallet, on the other hand, showed a 9.6 degree increase, or an 11.1 percent increase over ambient. For both pallets, temperature

increases in the middle container layers were 1-4 degrees over ambient. This clearly demonstrated that the outer containers of the pallet shielded the inner layers whether the pallet was protected or not.

3. Additional tests were conducted substituting canvas elevated above the pallet for sandbags placed directly on top of the ammunition. This test was to determine if materials readily available in SA could serve as solar radiation shields.

Exterior Skin Temperatures
Sandbag-Covered

Table 6

Test Number	Test Date	Ambient Temperature	Control Pallet	Test Pallet Covered	Temperature Differential
-----Top Containers-----					
1	9-13	85	115	88	27
2	9-15	78	105	78	28
-----Second Layer Containers-----					
1	9-13	85	86	85	1
2	9-15	78	79	79	0
-----Fourth Layer Containers-----					
1	9-13	85	85	85	0
2	9-15	78	79	78	1

4. During this test the top container layer of the unprotected pallet showed an average temperature increase of 27.5 degrees, or 34 percent over ambient (See Table 6). The sandbag-covered pallet, on the other hand, showed a 1.5 degree average temperature increase, or 2 percent over ambient. At different layers (within both pallets) there was very little difference in temperature, as noted previously.

5. Another pallet test evaluated a commercially available greenhouse shading material manufactured by DeWitt Company, Incorporated.

Pallet Solar Radiation Test
Exterior Skin Temperatures
DeWitt-Covered, 18-Inches Air Space

Table 7

Probe Location	Test Date	Ambient Temperature	Control Pallet	Test Pallet Covered	Temperature Differential
Top Layer	9-21	63	90	63	27
Second Row	9-21	63	63	63	-0

6. The unprotected pallet showed a 27 degree rise (42.8 percent increase) over ambient, while the covered pallet remained at ambient temperature, indicating a very effective thermal shield. The effectiveness was undoubtedly enhanced by the 18-inch air space between the cover and the pallet.

C. MILVAN TESTING.

1. In the final series of tests, a MILVAN loaded with inert 105mm howitzer cartridges was instrumented. Temperature probes were located in the following locations: the MILVAN roof, internal top of the load, internal center of the load, and test site ambient temperature. Tests were conducted with the doors open and closed.

Milvan Solar Radiation Test Exterior/Interior Temperatures

Table 8

Test Number	Test Date	Ambient Temperature	Milvan Roof	Interior Top	Middle
-----Doors Closed-----					
1	9-5	91	135	120	99
2	9-6	92	130	115	96
3	9-7	81	116	108	94
4	9-8	81	127	109	91
5	9-9	82	129	114	95
6	9-10	85	135	120	97
Average		85	129	114	95
-----Doors Open-----					
1	9-11	80	122	101	84
2	9-12	82	118	102	85
3	9-13	84	129	108	87
Average		82	123	104	85

2. During this test solar radiation generated an average roof temperature of 129 degrees Fahrenheit (closed door) and 123 degrees Fahrenheit (open door). Of particular interest during this test was an average 10 degree temperature drop within the MILVAN when the doors were

open versus the doors being closed and the middle probe being within 3 degrees Fahrenheit of ambient on the open door MILVAN. This test demonstrated thermal convection (cooling effect) on the open-door MILVAN with hot air leaving the top and cooler air entering the bottom of the MILVAN.

PART 6

DISCUSSION

- a. In lieu of protective covering, empty containers/boxes should be used as shielding materials both on the top and sides of the pallets to avoid solar radiation (reference inner layers remained close to ambient temperature with little heat transfer) with or without protective covering.
- b. There is no direct correlation between ammunition skin temperature and ambient temperature, it is dependent on such variables as wind speed/direction, length of exposure, cloud cover, amount of particulate in the air, color, and thermal mass of the ammunition. All of these factors have an effect on the amount of solar radiation received by the ammunition.
- c. Heat damage to ammunition cannot be determined by skin temperature probes alone, due to the thermal lag and heat transfer into the rounds. Therefore, internal thermal couples should be used on inert ammunition in the future to determine what temperature the ammunition is experiencing.
- d. Sandbags covering ammunition appear to be a very suitable solar radiation cover for ammunition. Due to the mass of sandbags, wind would have little effect on the covering. This is an inherent problem with other thermal shields on how to keep them in place during high winds.
- e. If MILVANS are used for ammunition storage, the doors should remain open with the door opening directed away from the sunlight.

PART 7

PHOTOGRAPHS



U.S. ARMY DEFENSE AMMUNITION CENTER AND
SCHOOL - SAVANNA, IL

Photo No. AO317-SPN-90-367-6383 This photo is a typical example of a solar material screening test. Note, four different materials are being evaluated during this test.

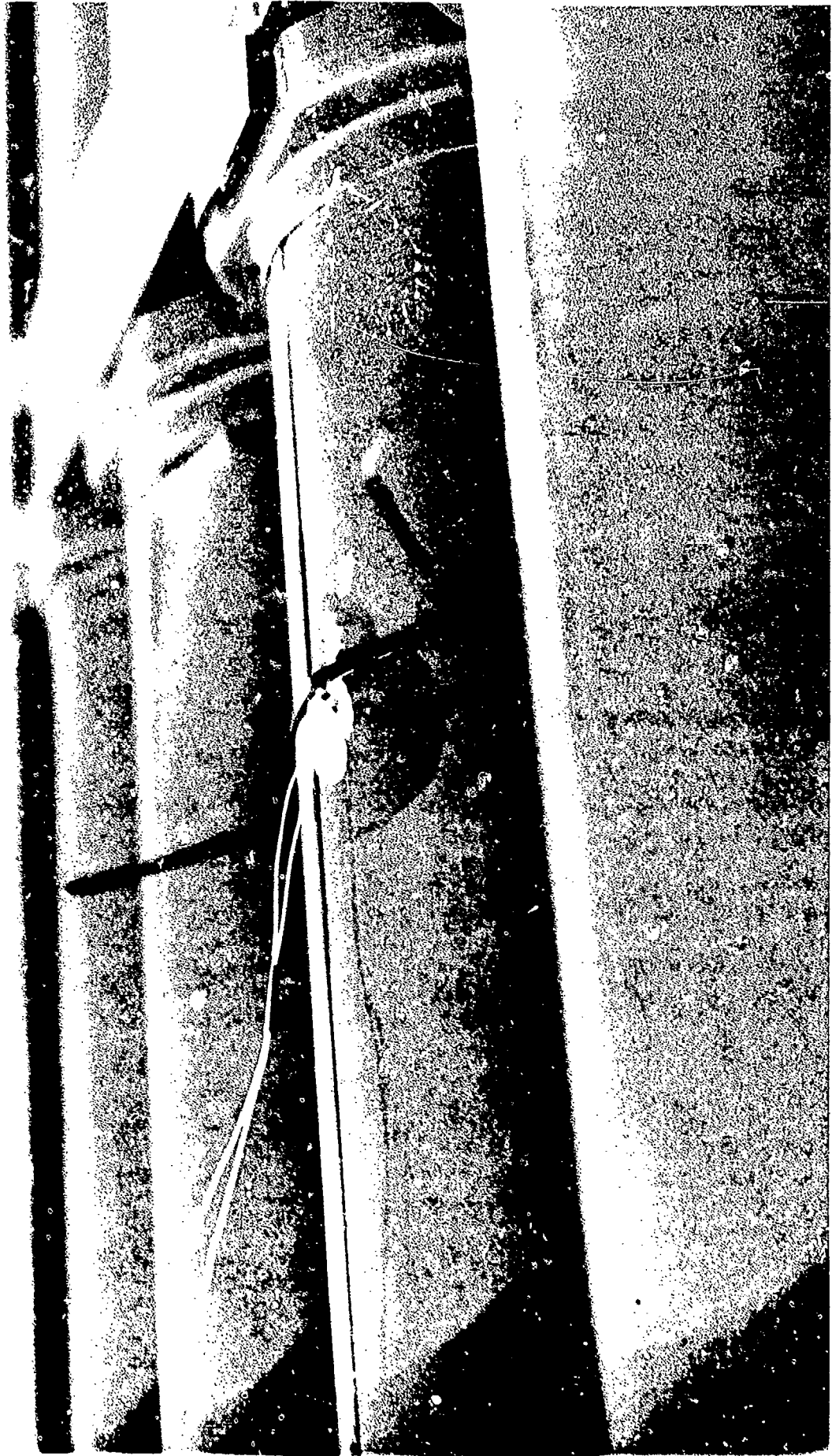

U.S. ARMY DEFENSE AMMUNITION CENTER AND SCHOOL - SAVANNA, IL

Photo No. AO317-SPN-90-367-6386. This photo is a typical application of a thermal couple to 120mm metal container during solar radiation testing.

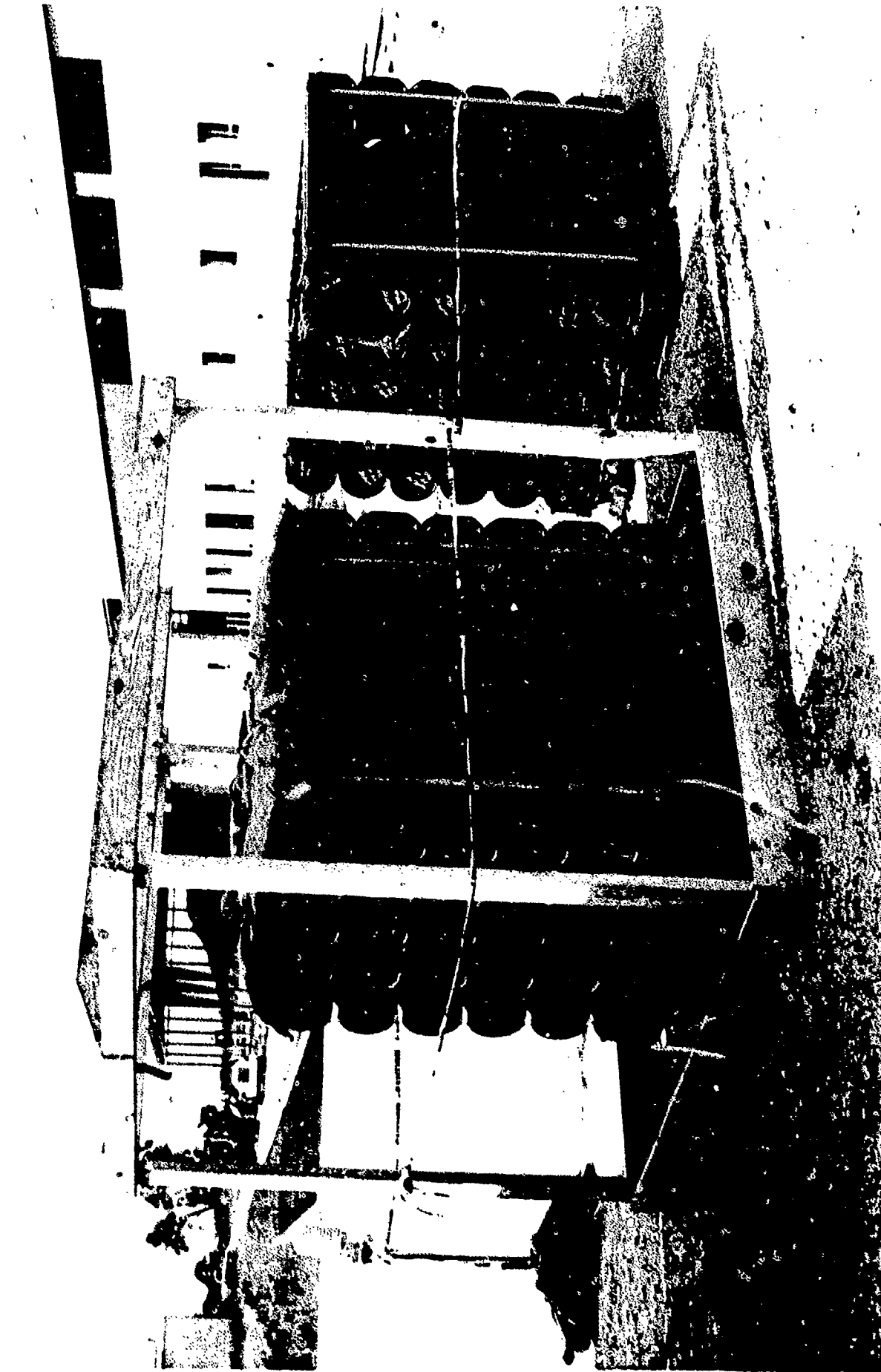

U.S. ARMY DEFENSE AMMUNITION CENTER AND SCHOOL - SAVANNA, IL

Photo No. AO317-SPN-90-367-6394. This photo is a typical test setup for pallet testing using 120mm tank rounds.
Note, sandbags being evaluated during this test.

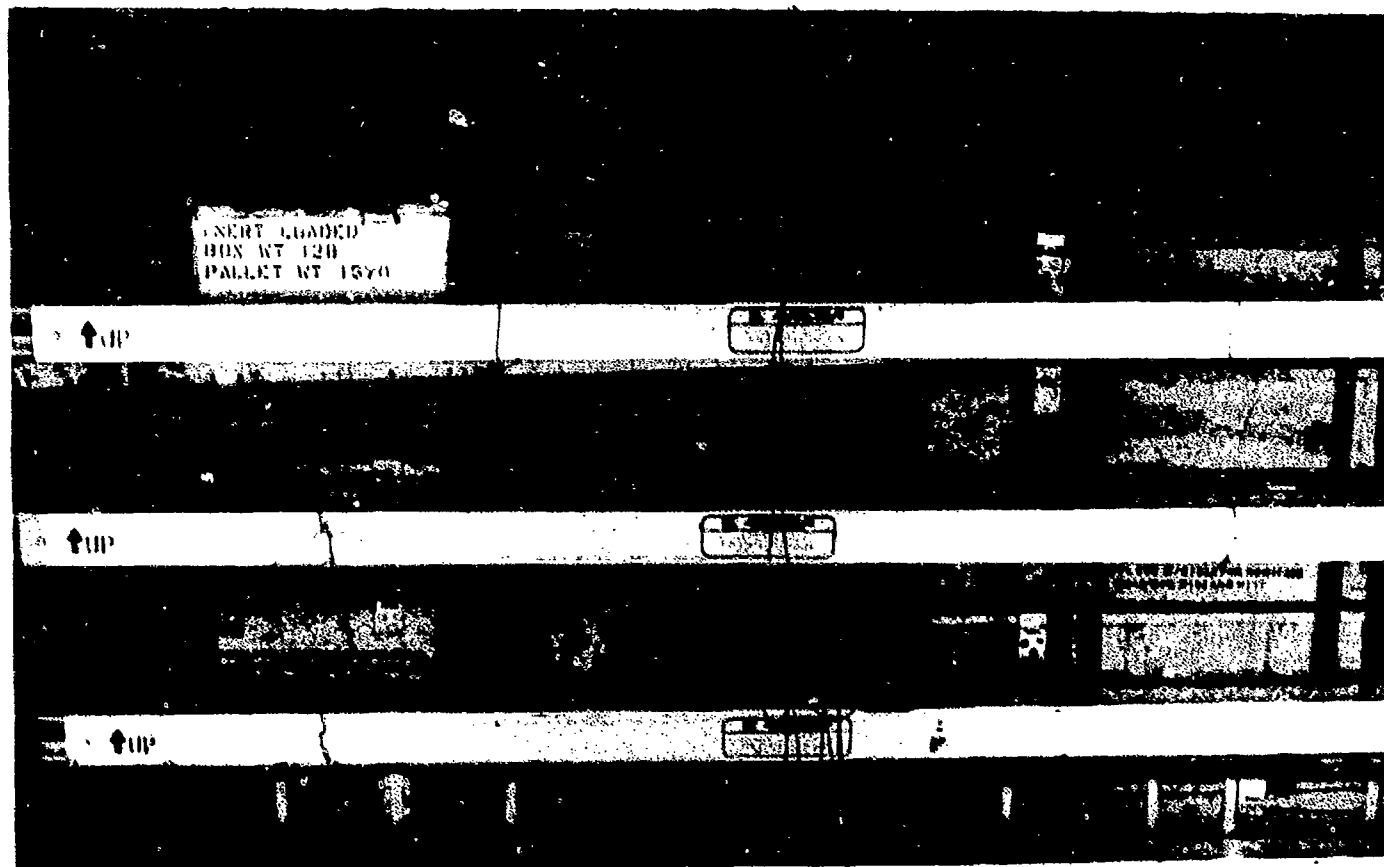
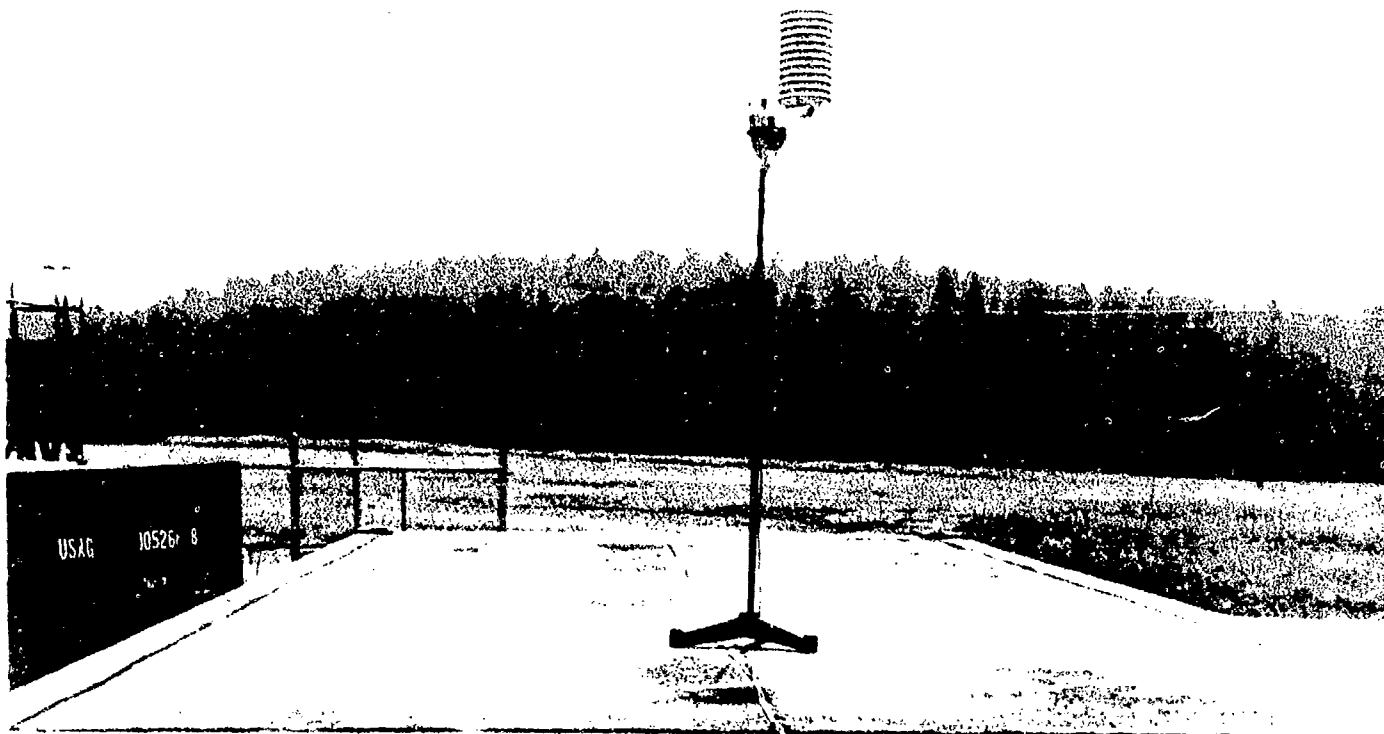

	<p align="center">U.S. ARMY DEFENSE AMMUNITION CENTER AND SCHOOL - SAVANNA, IL</p>	
<p>This photo is a typical example of MILVAN testing using inert 105mm cartridge HE. Note, ambient temperature and humidity probe on top of MILVAN during this test.</p>		

PART 8

GRAPHS

Solar Shield Test

Test Date: 08/17-20/90

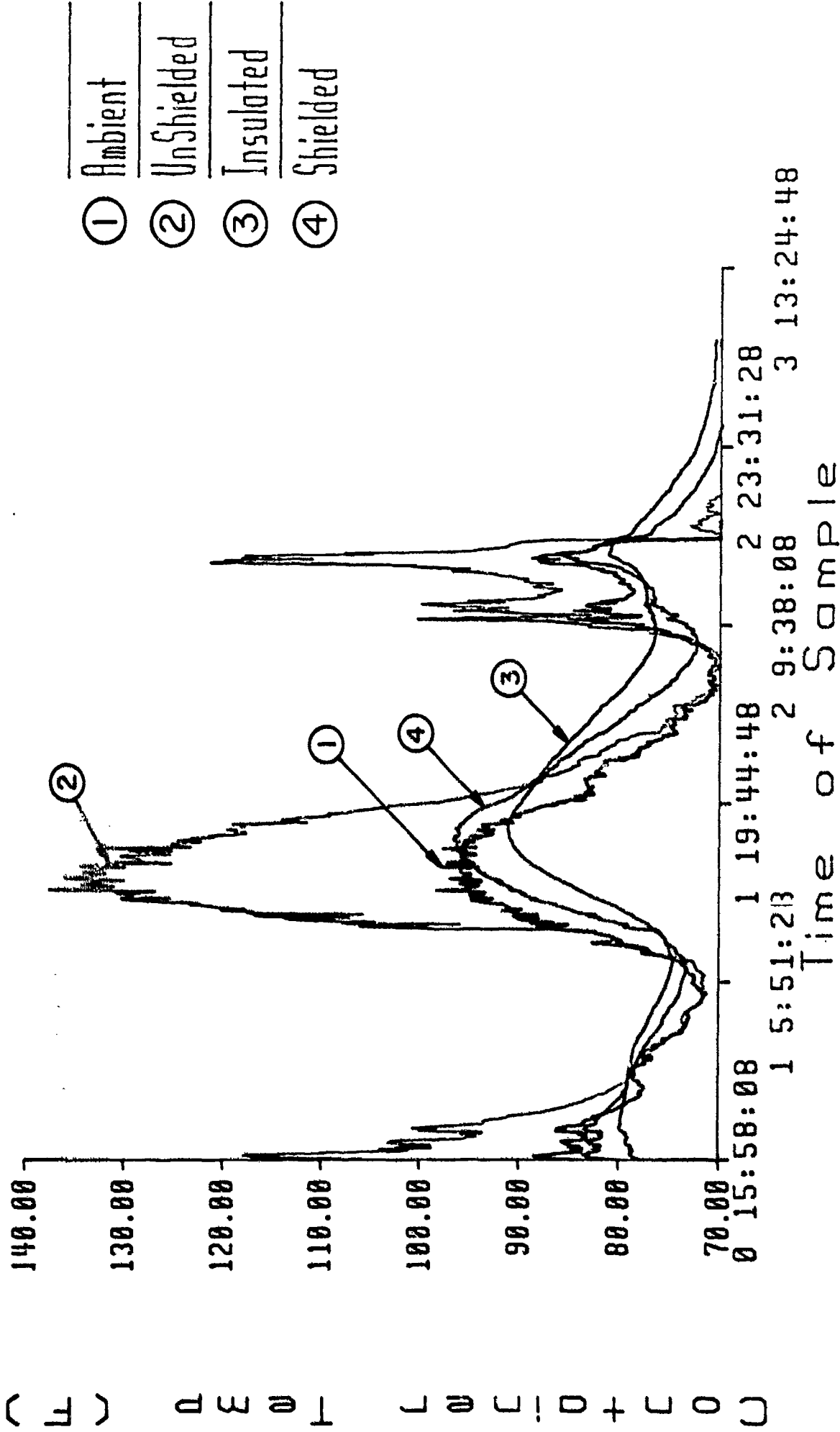

GRAPH NO. 1

Solar Shield Test

Test Date: 08/24-27/90

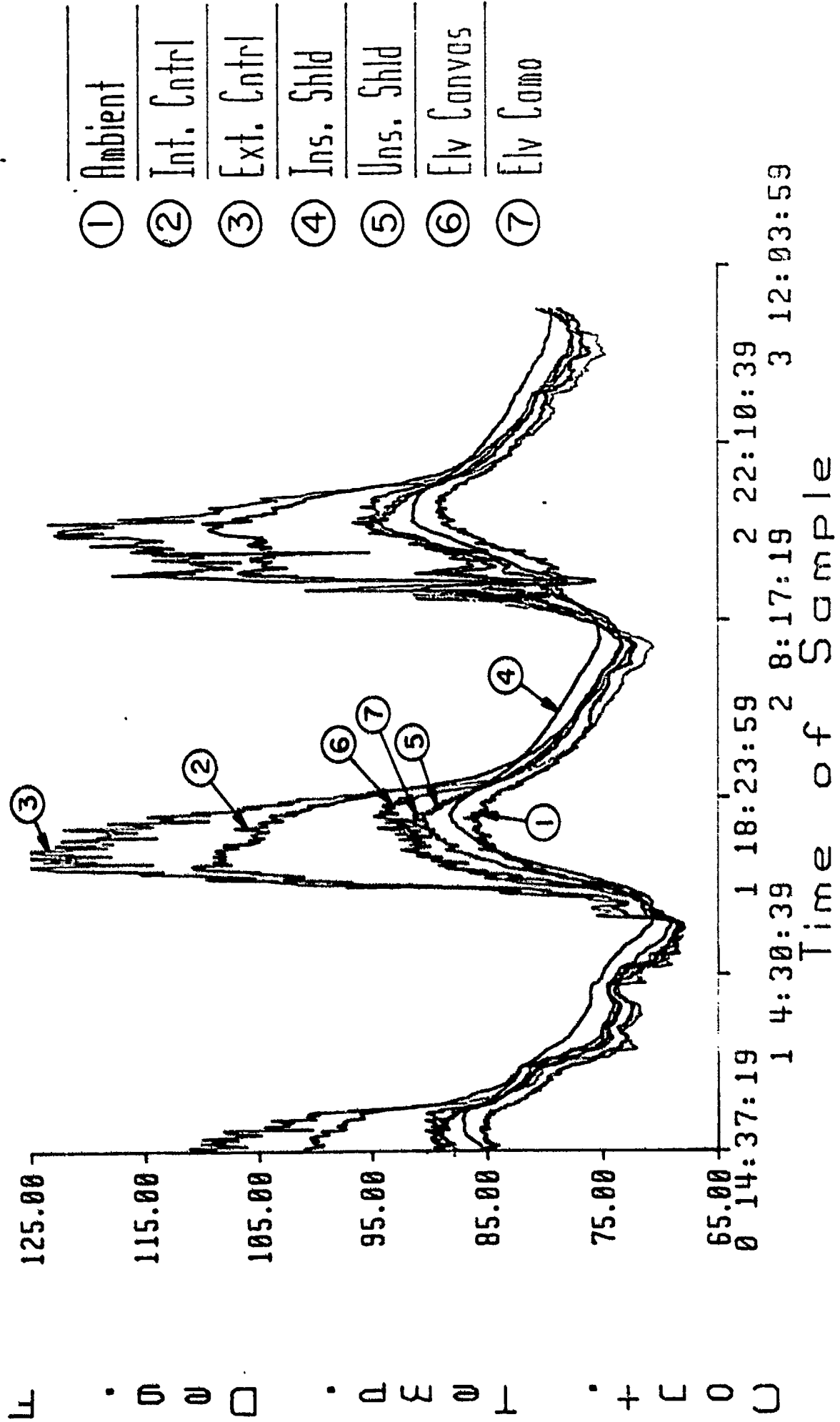

Solar Shield Test

Test Date: 08/27-29/90

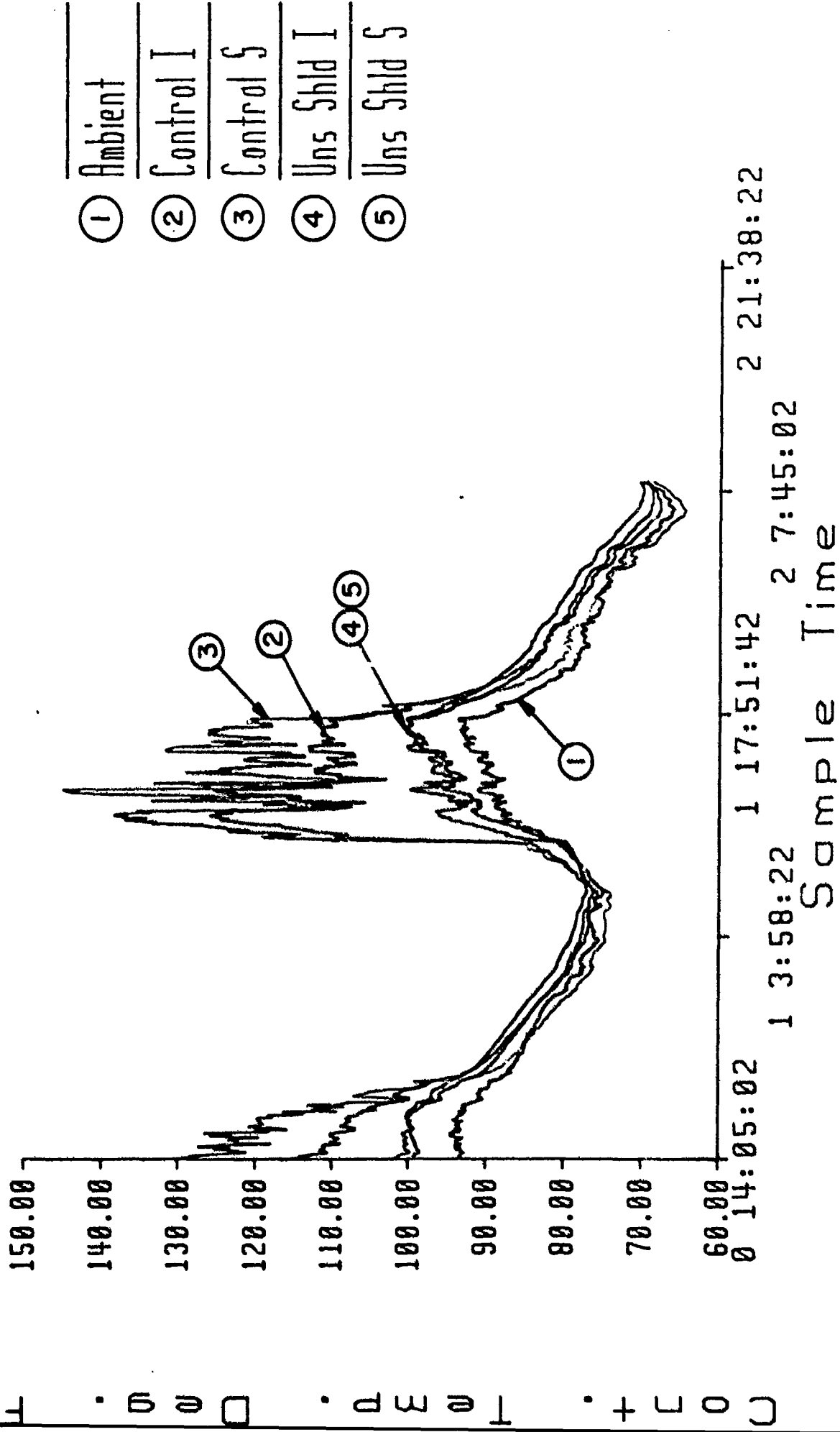

Solar Shield Test

Test Date: 08/27-29/90

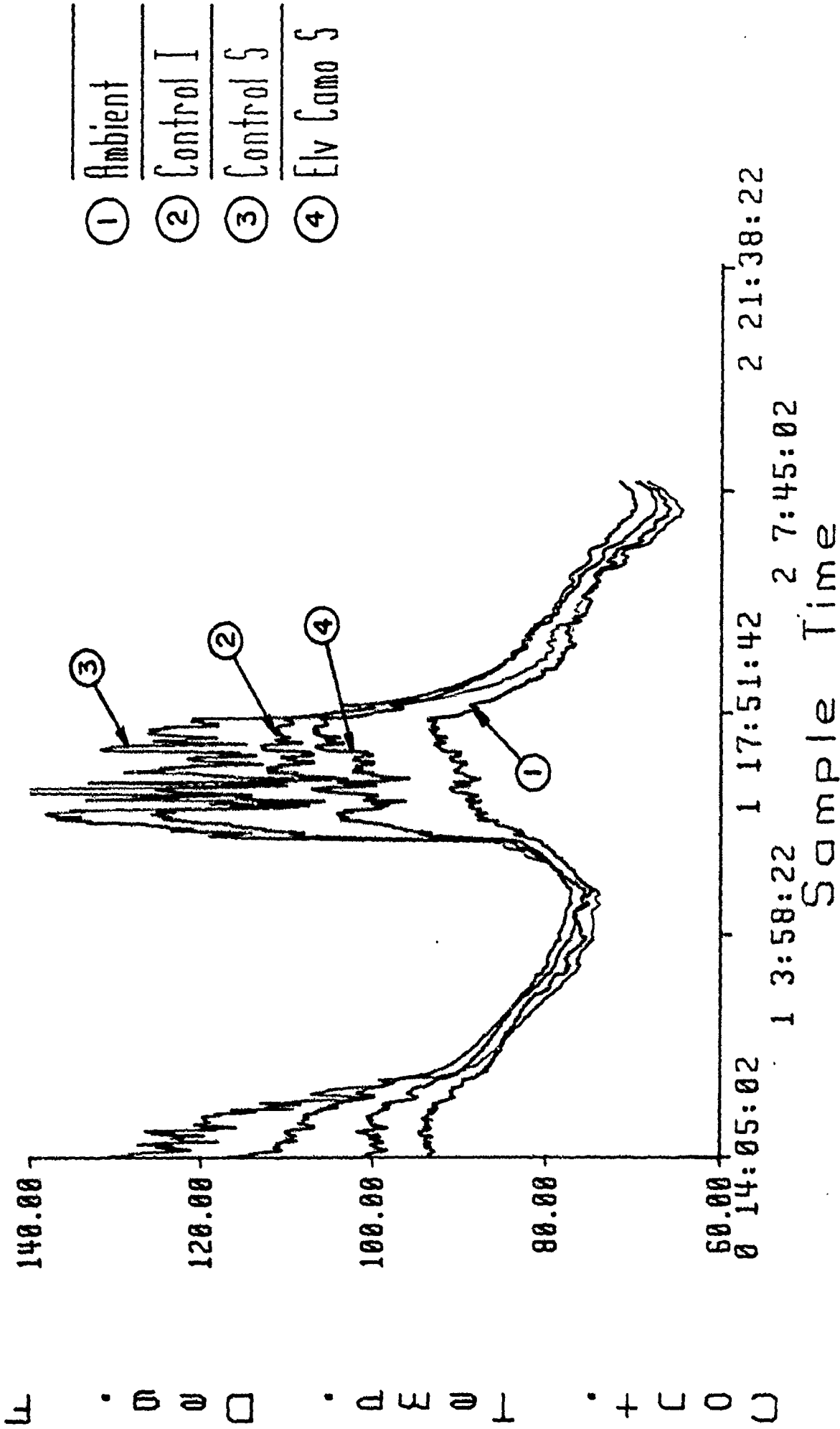

GRAPH NO. 4

Solar Shield Test

Test Date: 08/29-30/90

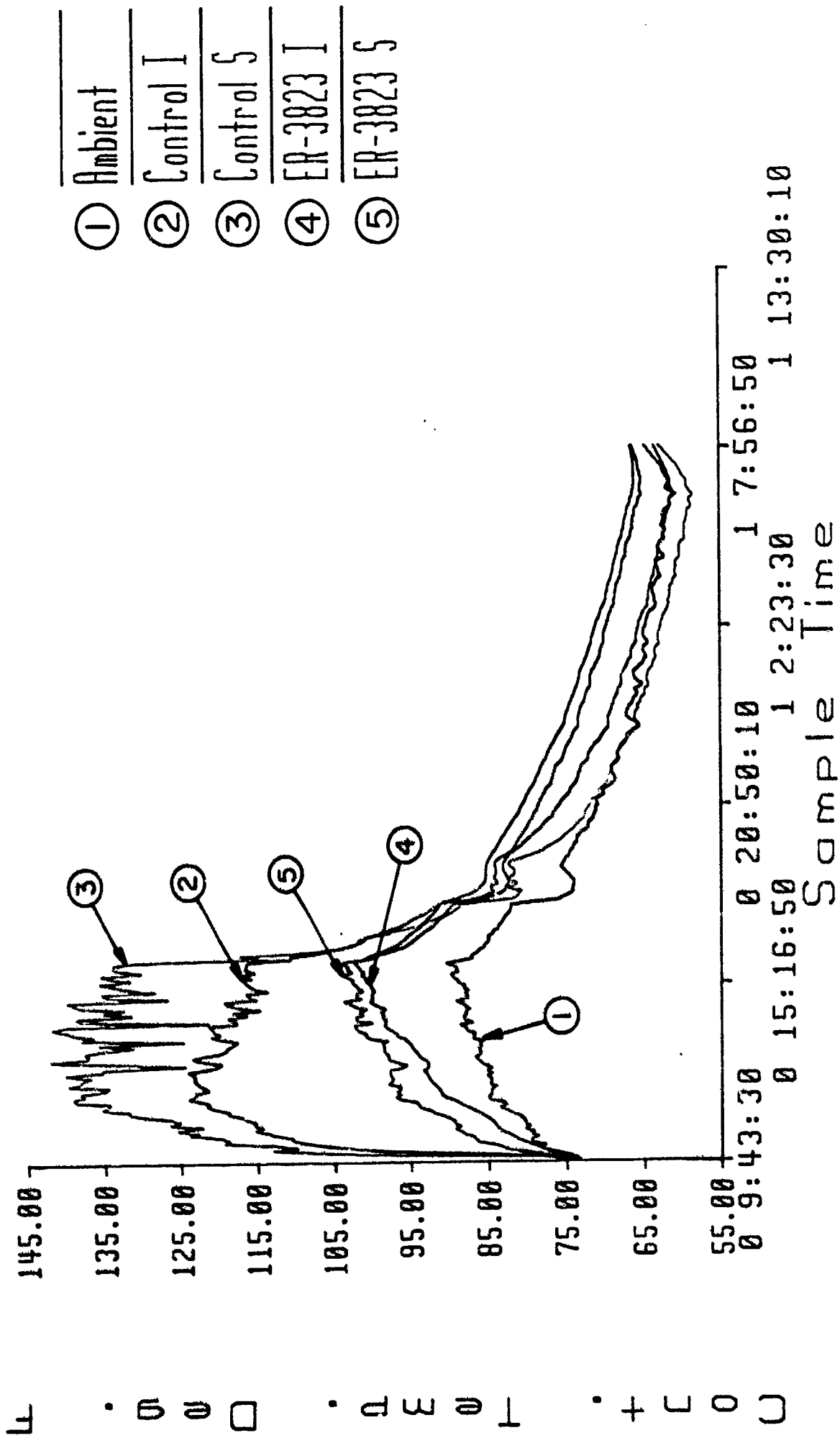

Solar Shield Test

Test Date: 08/30-31/90

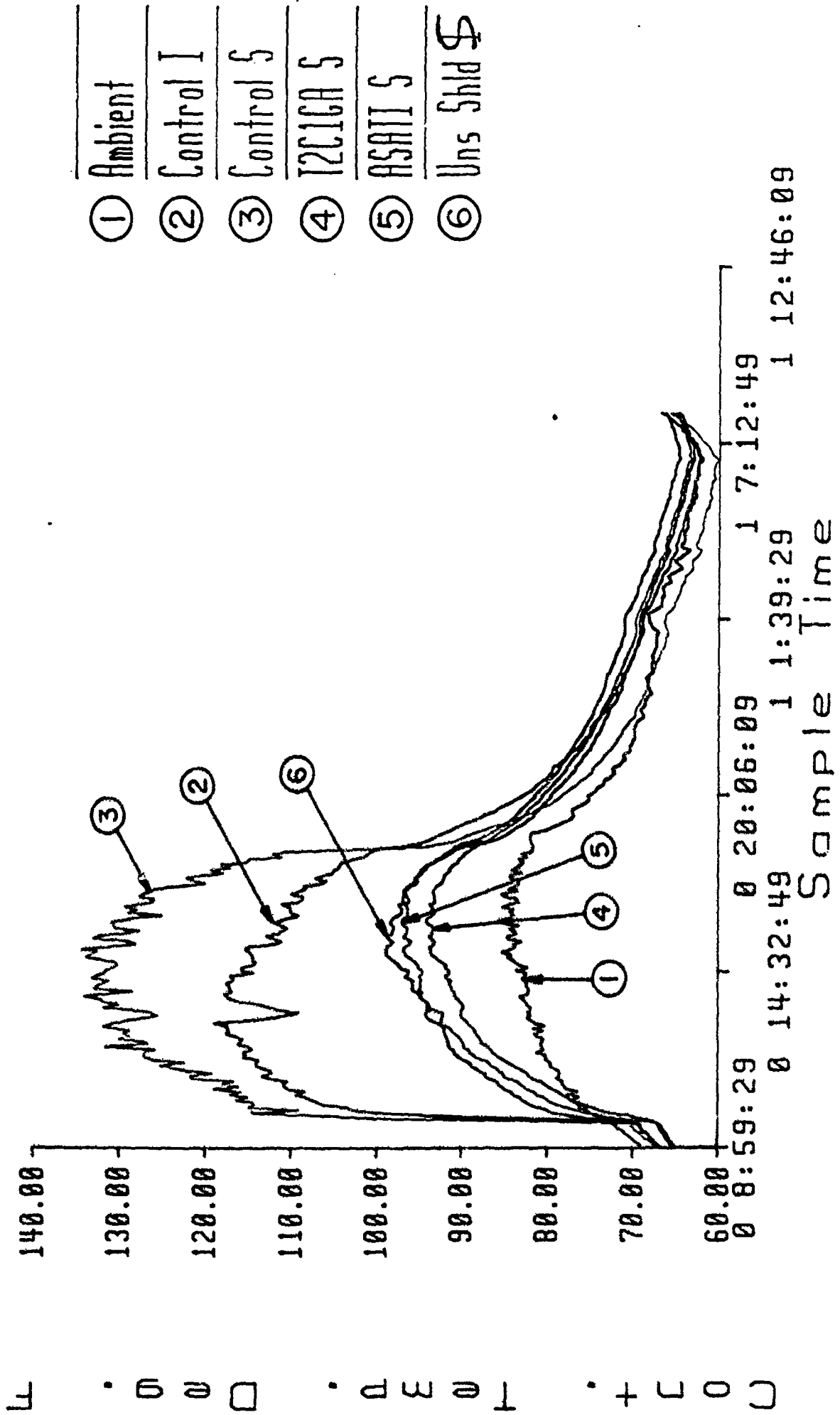

Solar Shield Test

Test Date: 08/30-31/90

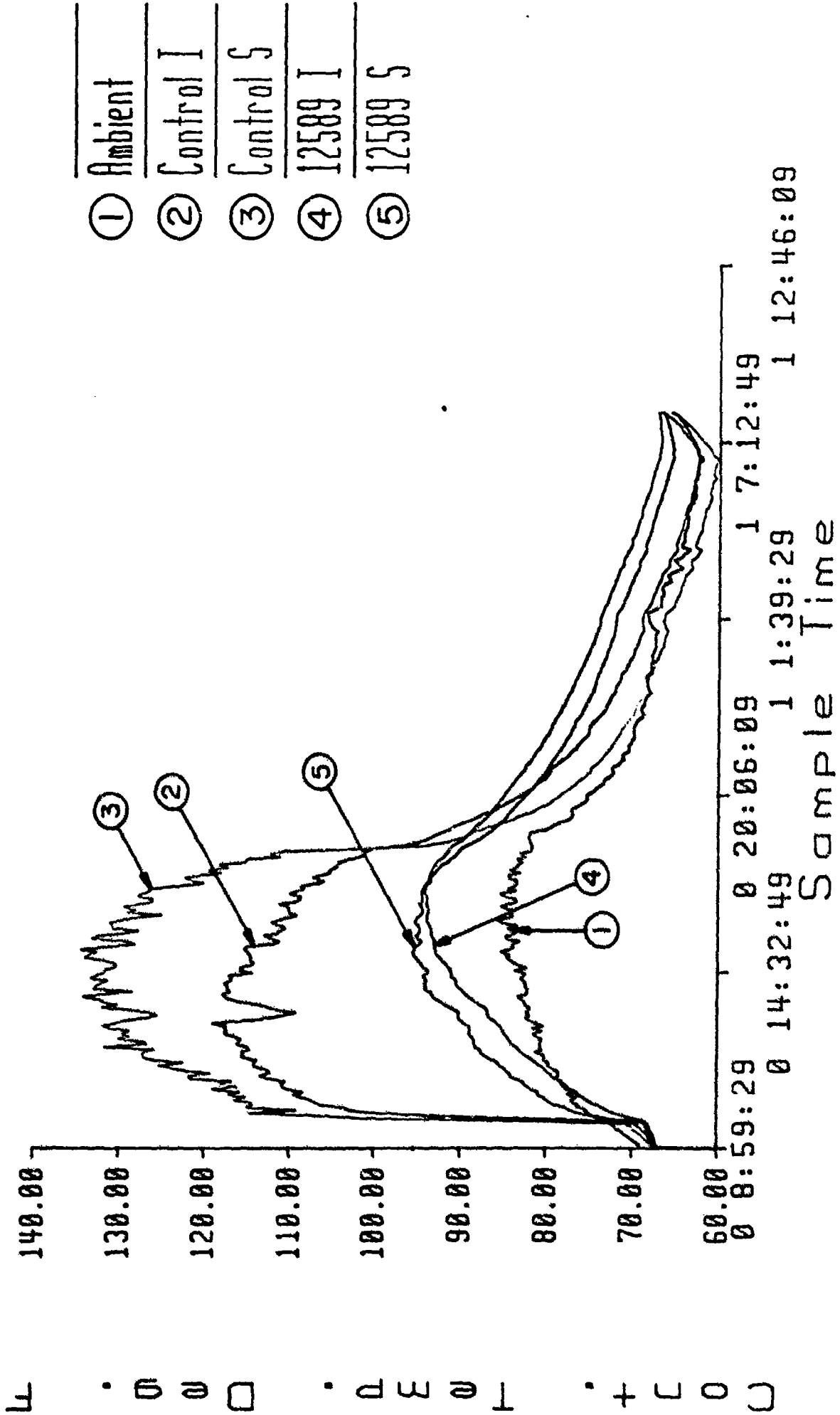

GRAPH NO. 7

Solar Shield Test

Test Date: 09/04-05/90

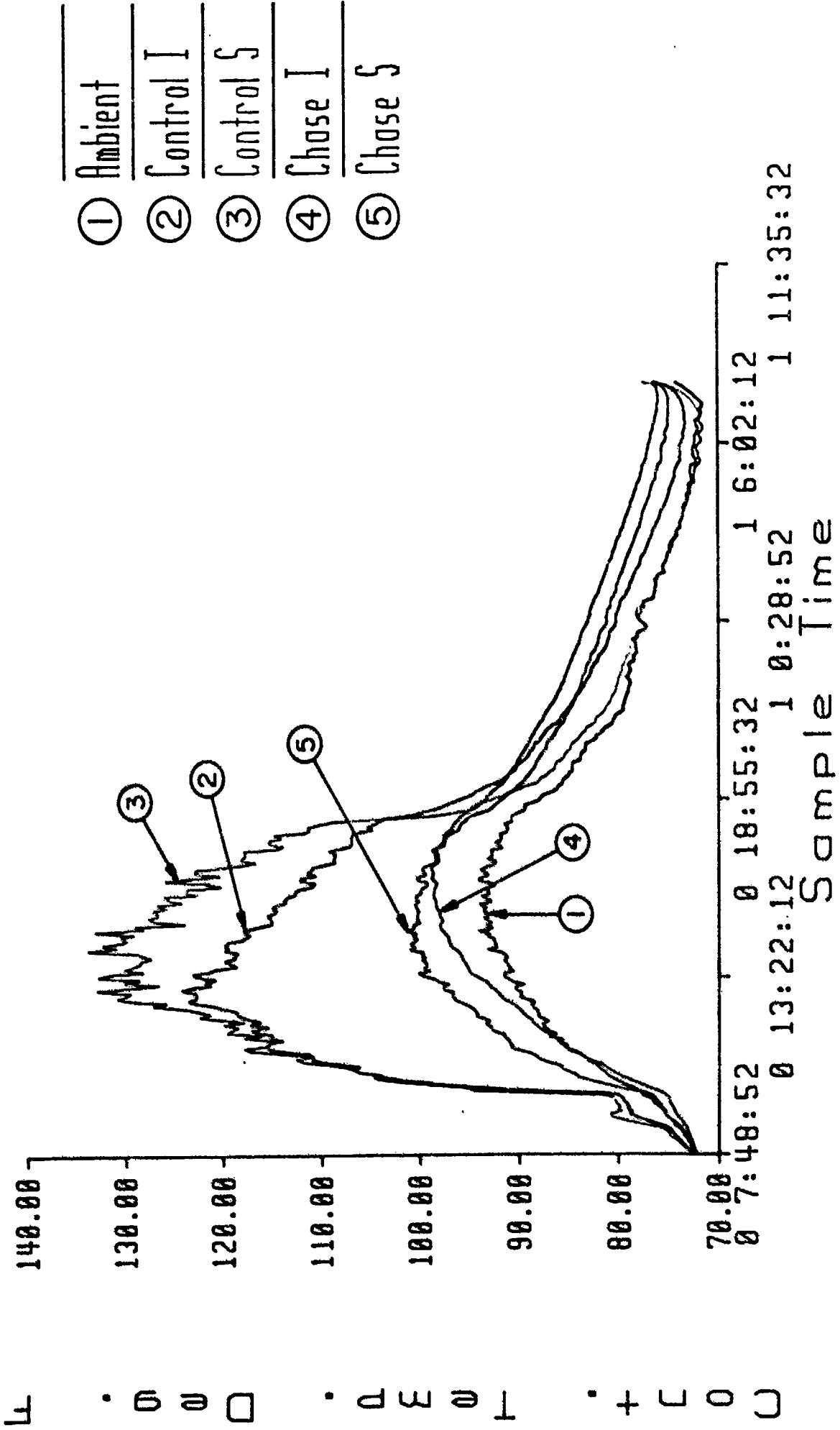

Solar Shield Test

Test Date: 09/26-28/90

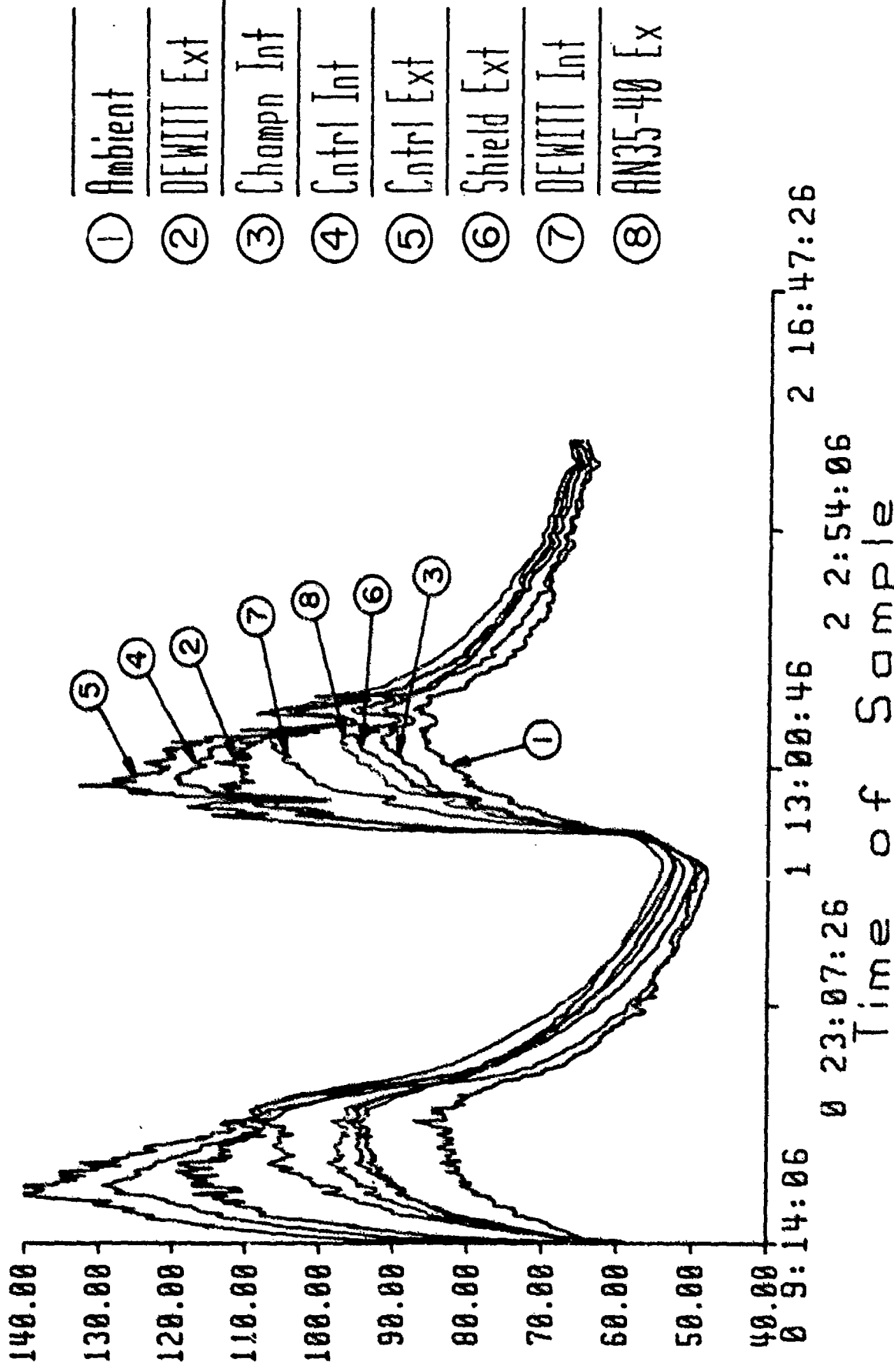

- ① Ambient
- ② DEWITT Ext
- ③ Champn Int
- ④ Cntrl Int
- ⑤ Cntrl Ext
- ⑥ Shield Ext
- ⑦ DEWITT Int
- ⑧ AN35-40 Ex

GRAPH NO. 9

Solar Shield Test

Test Date: 09/05-06/90

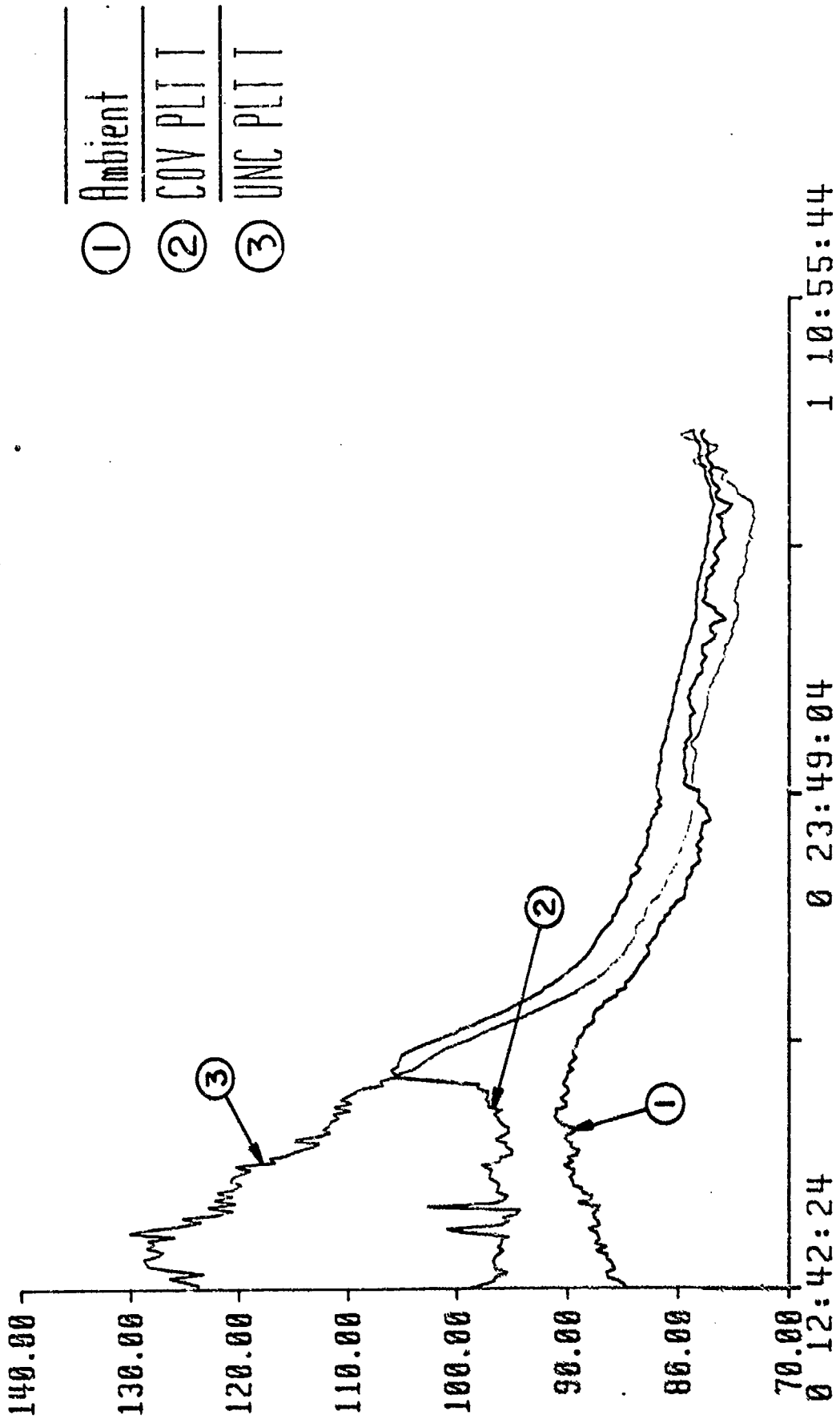

Sample Time

Solar Shield Test

Test Date: 09/05-06/90

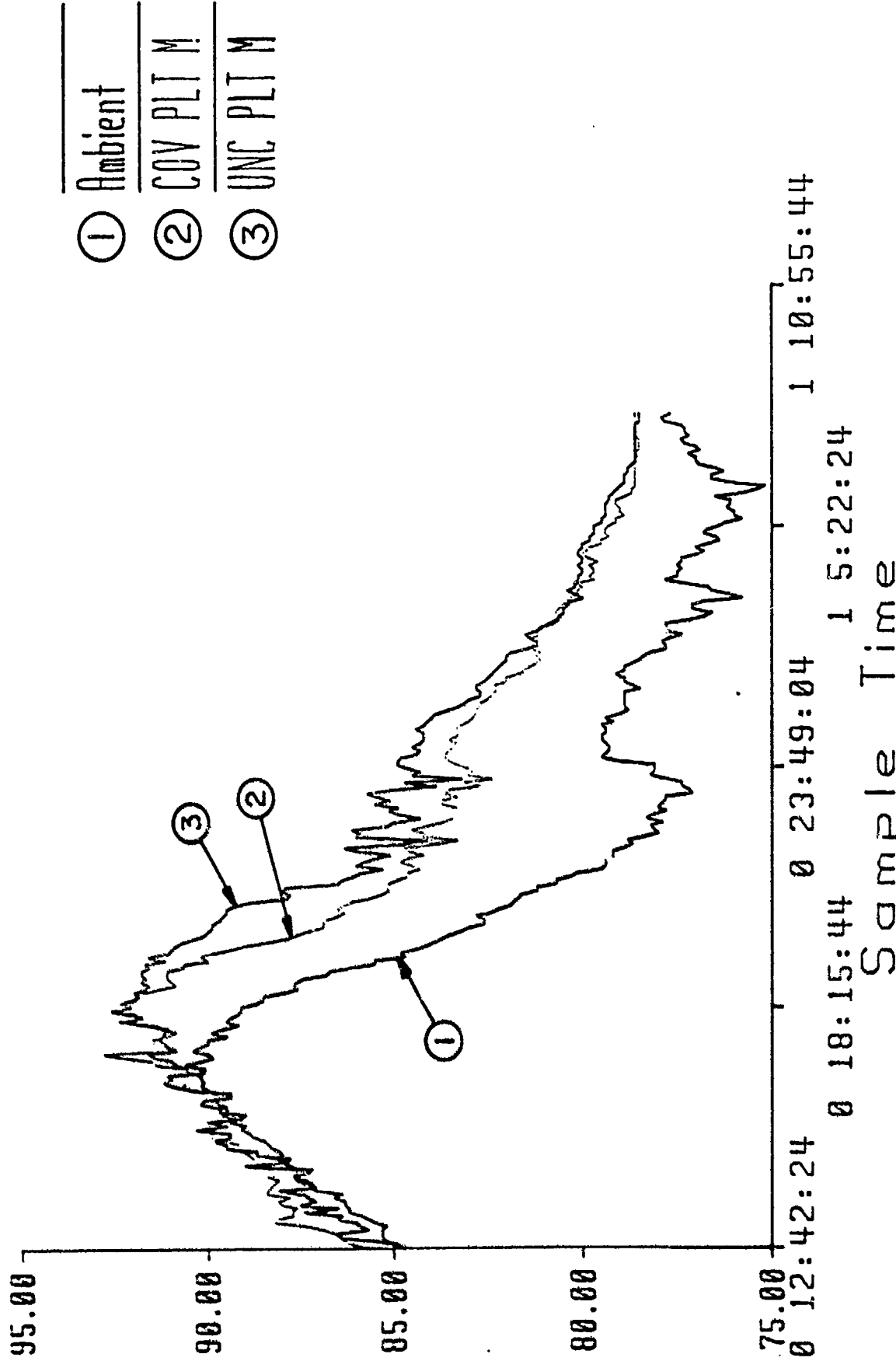

Solar Shield Test

Test Date: 09/06-07/90

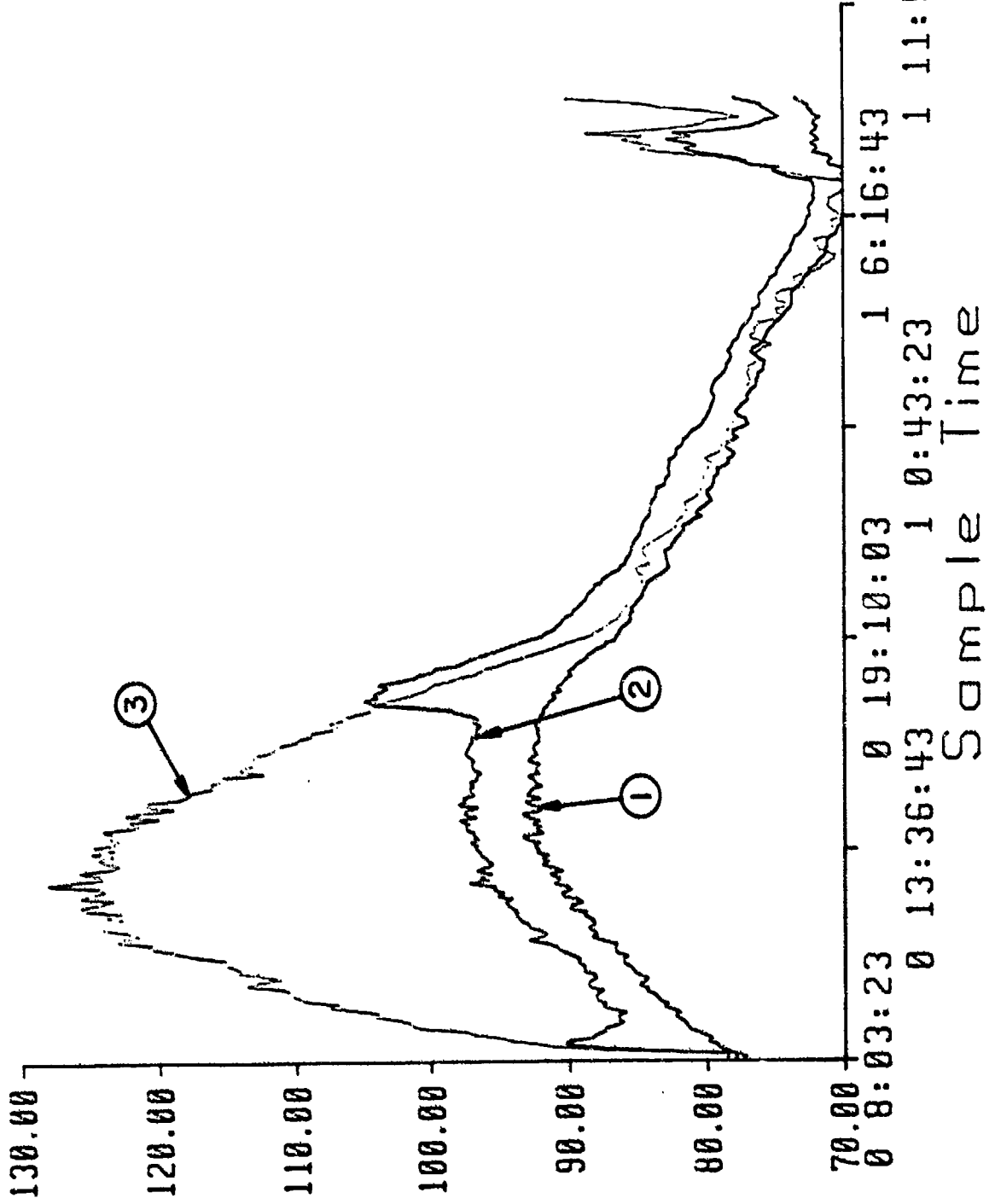

- ① Ambient
- ② COV PLT I
- ③ UNC PLT I

Solar Shield Test

Test Date: 09/07-10/90

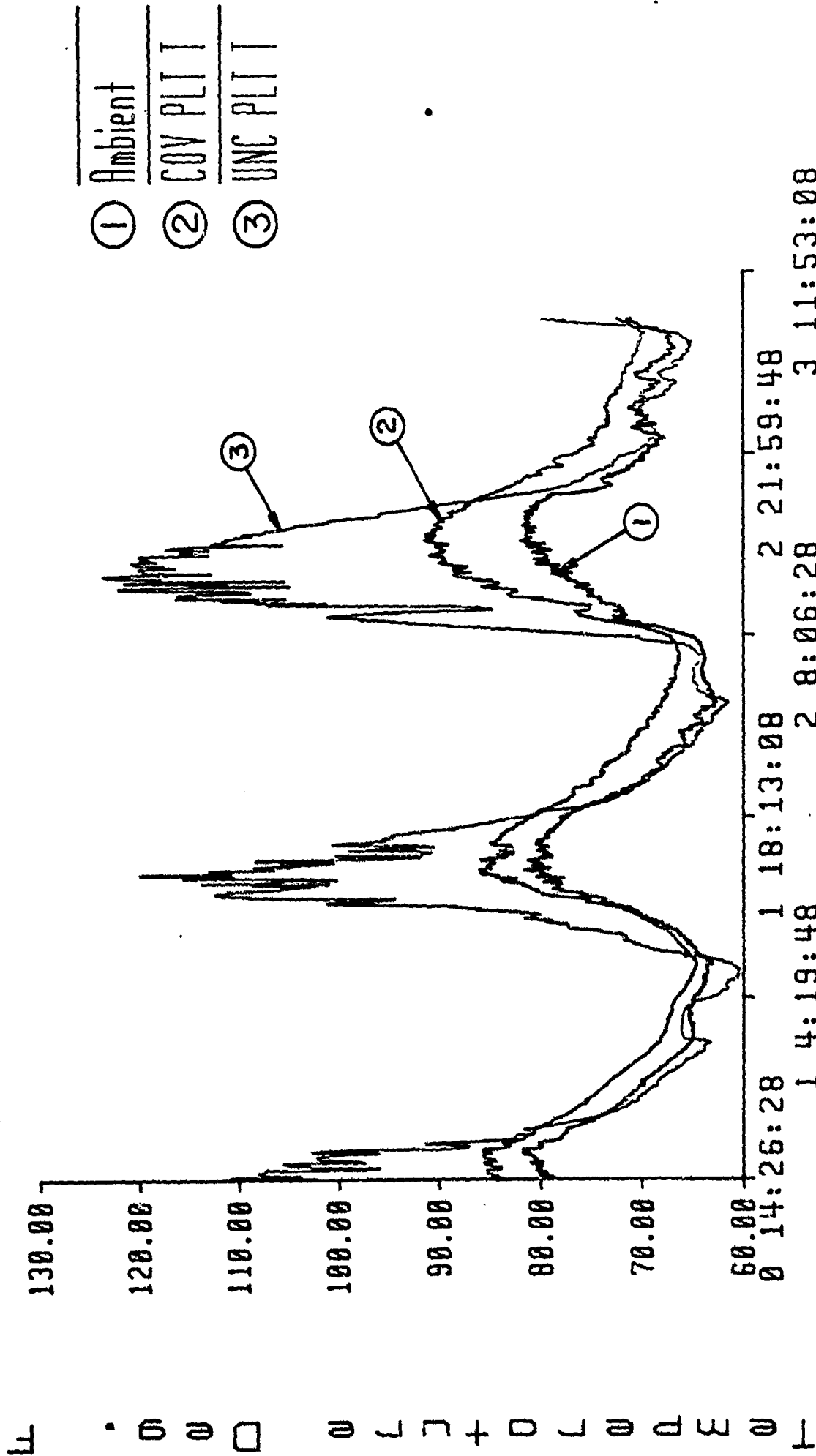

Sample Time

GRAPH NO. 13

Solar Shield Test 09/07-10/90

Test Date:

- ① Ambient
- ② COV PLT M
- ③ UNC PLT M



65.00
70.00
75.00
80.00
85.00

1 14:26:28 1 18:13:08 2 8:06:28 2 21:59:48 3 11:53:08

Sample Time

GRAPH NO. 14

Temperature

Solar Shield Test

Test Date: 09/12-13/90

W C
 . 0
 0 0
 0 0
 0
 0 L
 L 0
 J 0
 + 0
 L C
 0 0
 0 >
 E =
 0 Σ
 T V

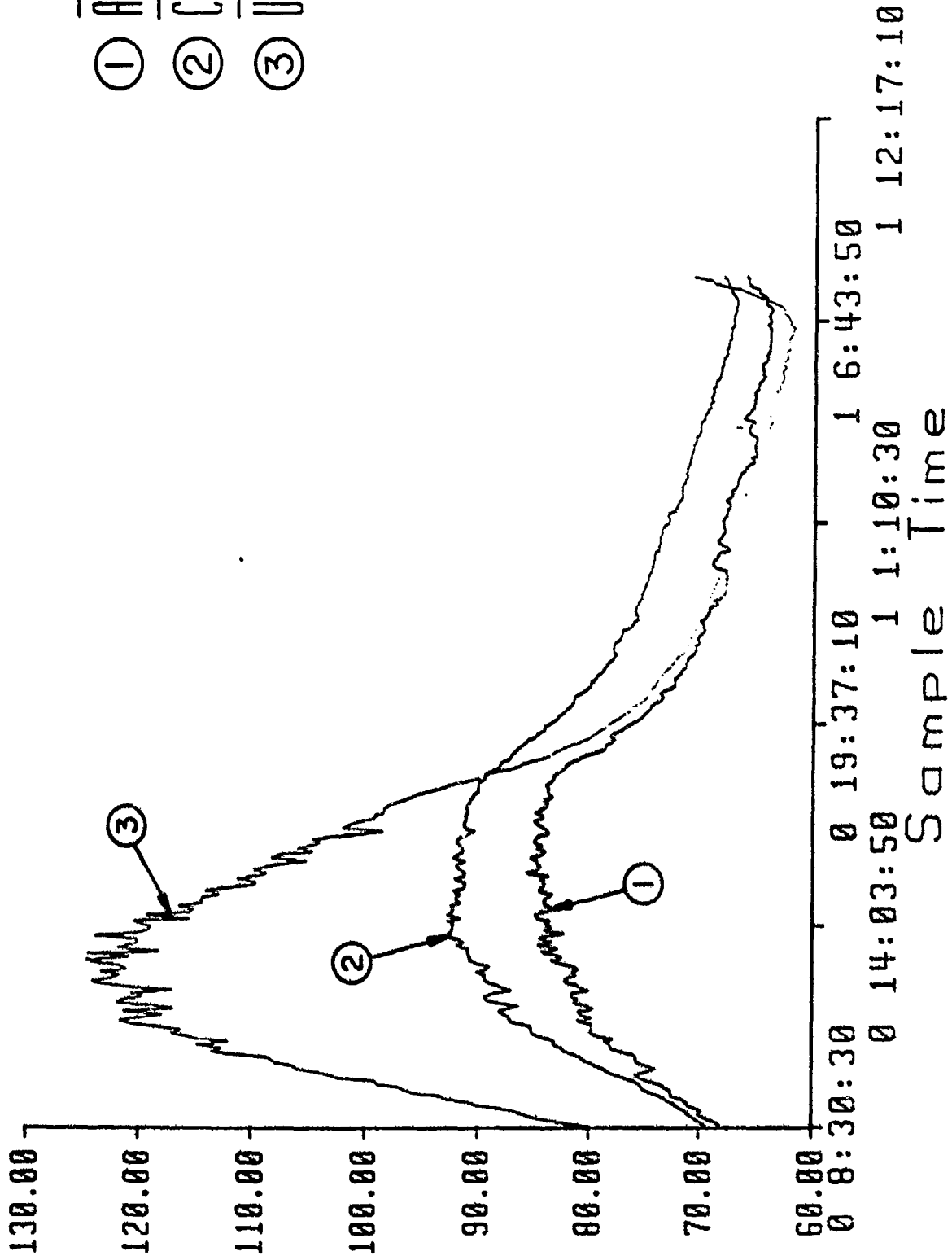

Solar Shield Test

Test Date: 09/14-17/90

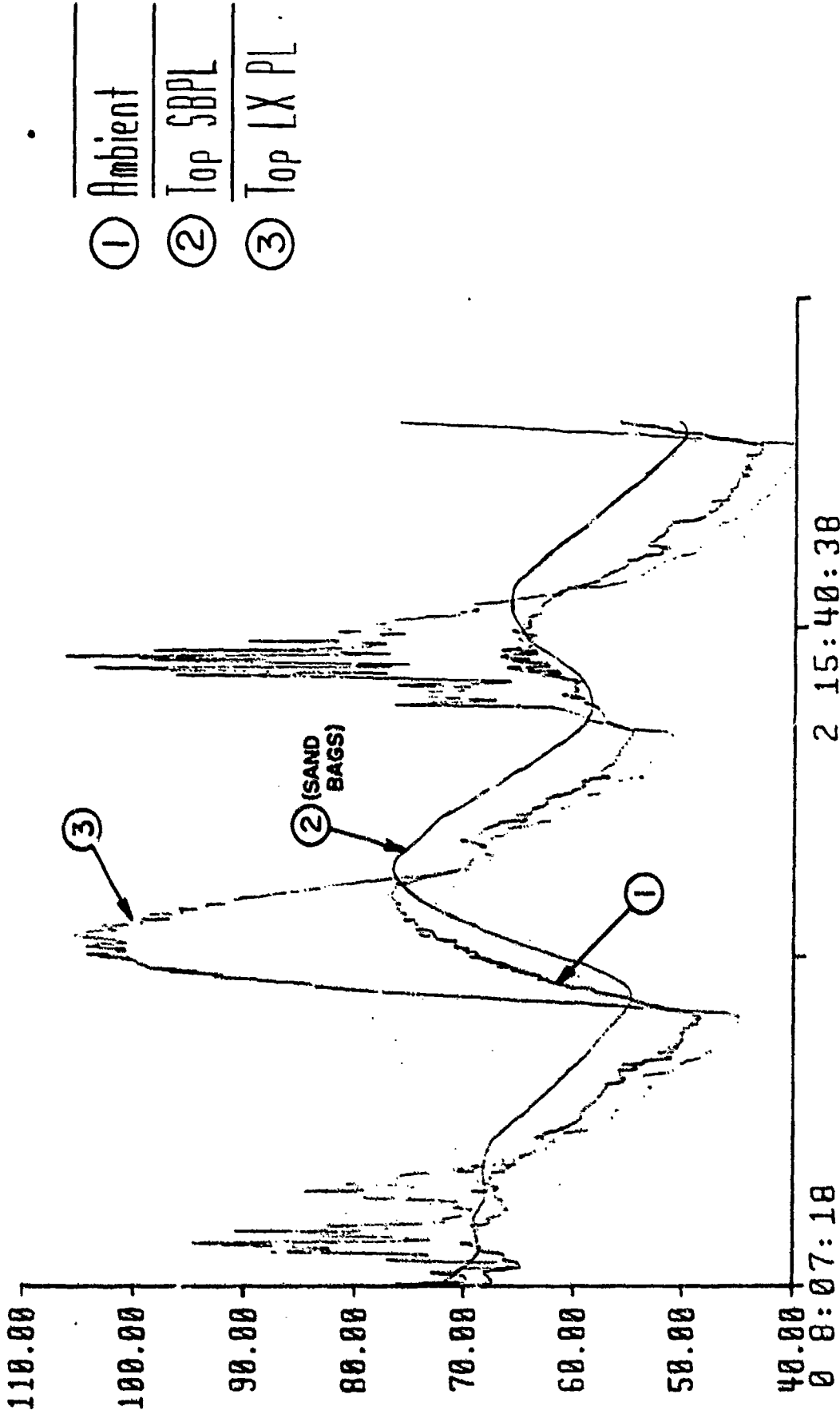

Solar Shield Test

Test Date: 09/14-17/90

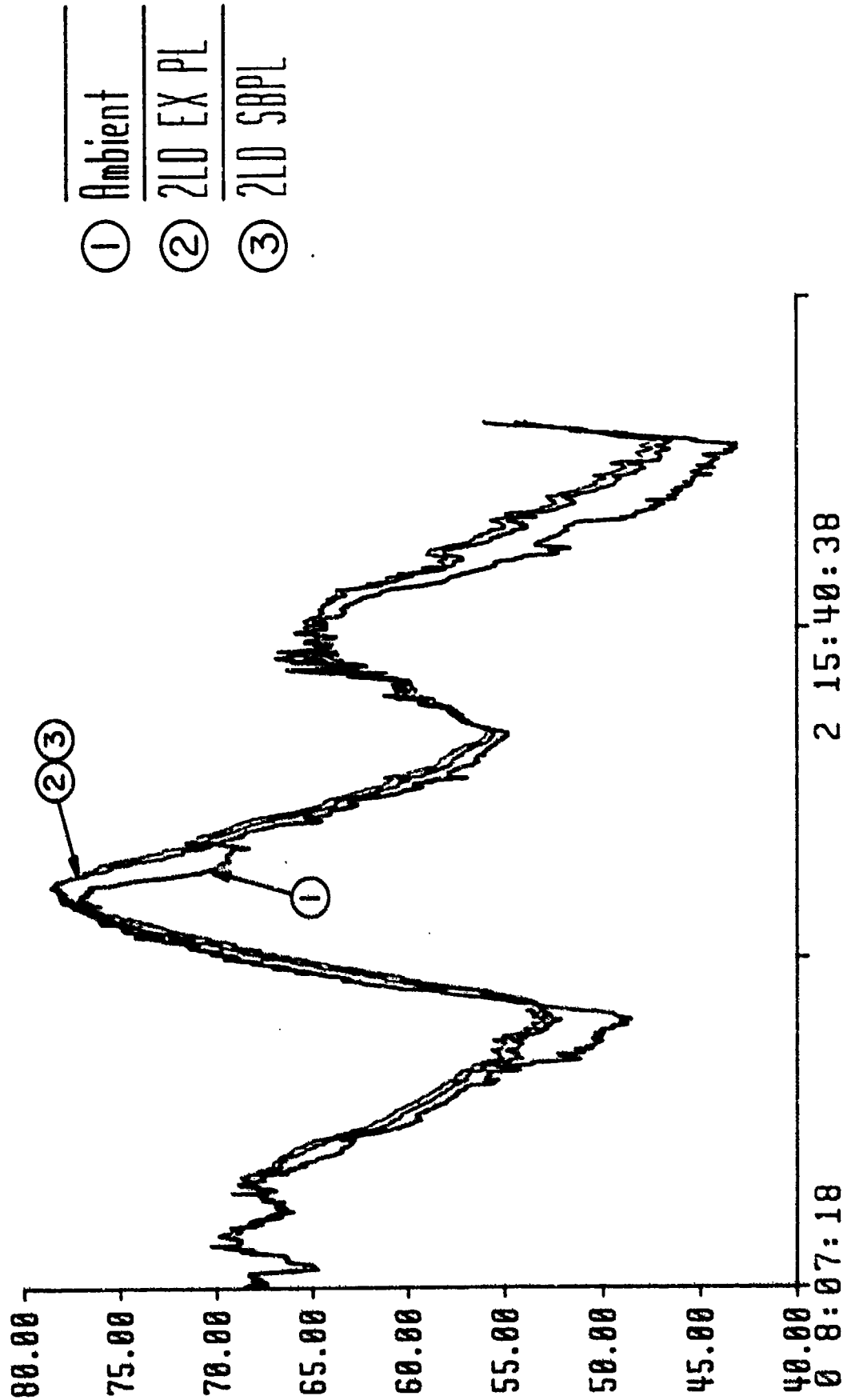

1 11:53:59
Time of Sample
2 15:40:38
3 19:27:18

GRAPH NO. 17

Solar Shield Test

Test Date: 09/05-06/90

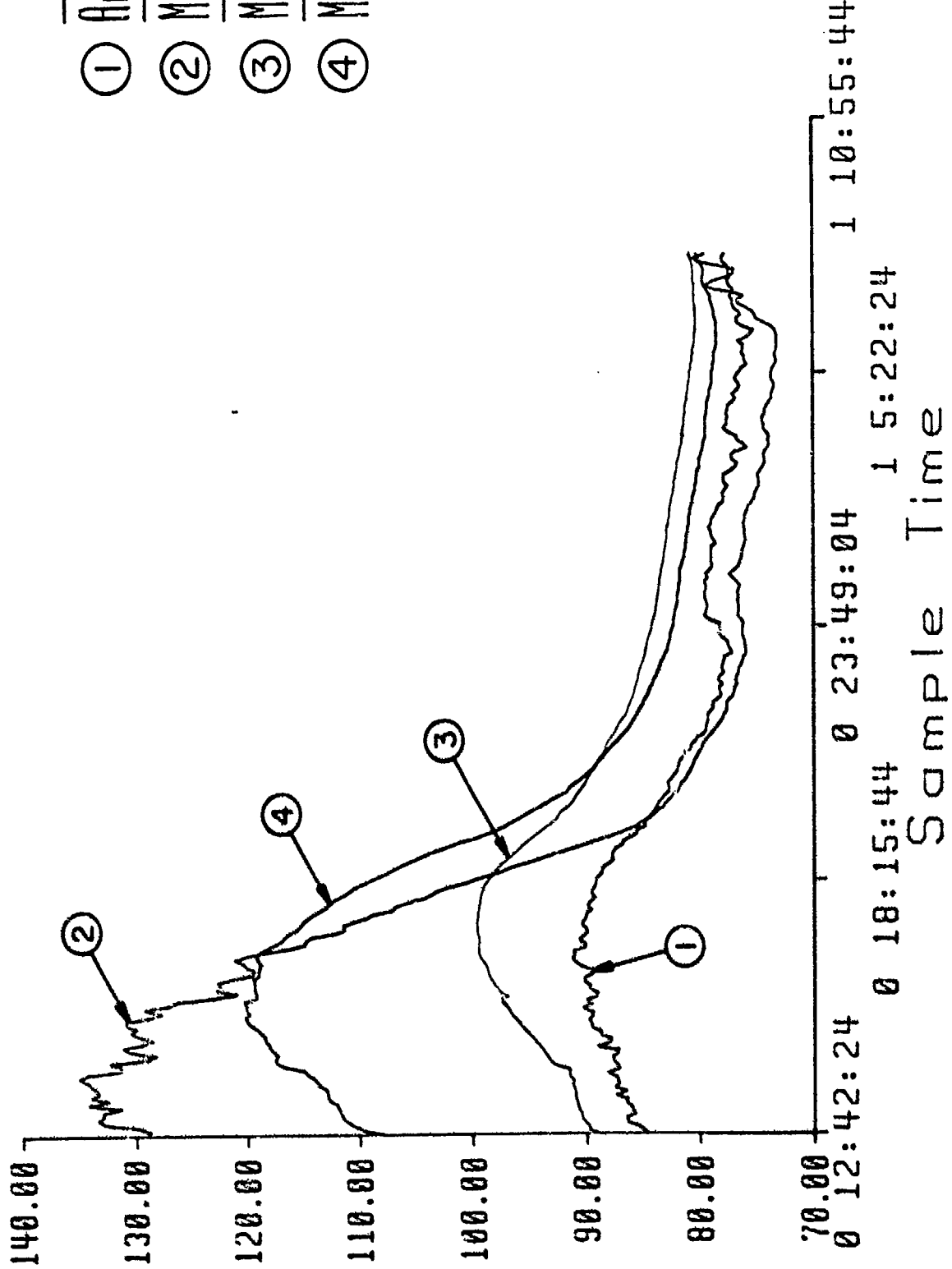

- ① Ambient
- ② Milv Roof
- ③ Milv M. I
- ④ Milv J. I

Solar Shield Test

Test Date: 09/06-07/90

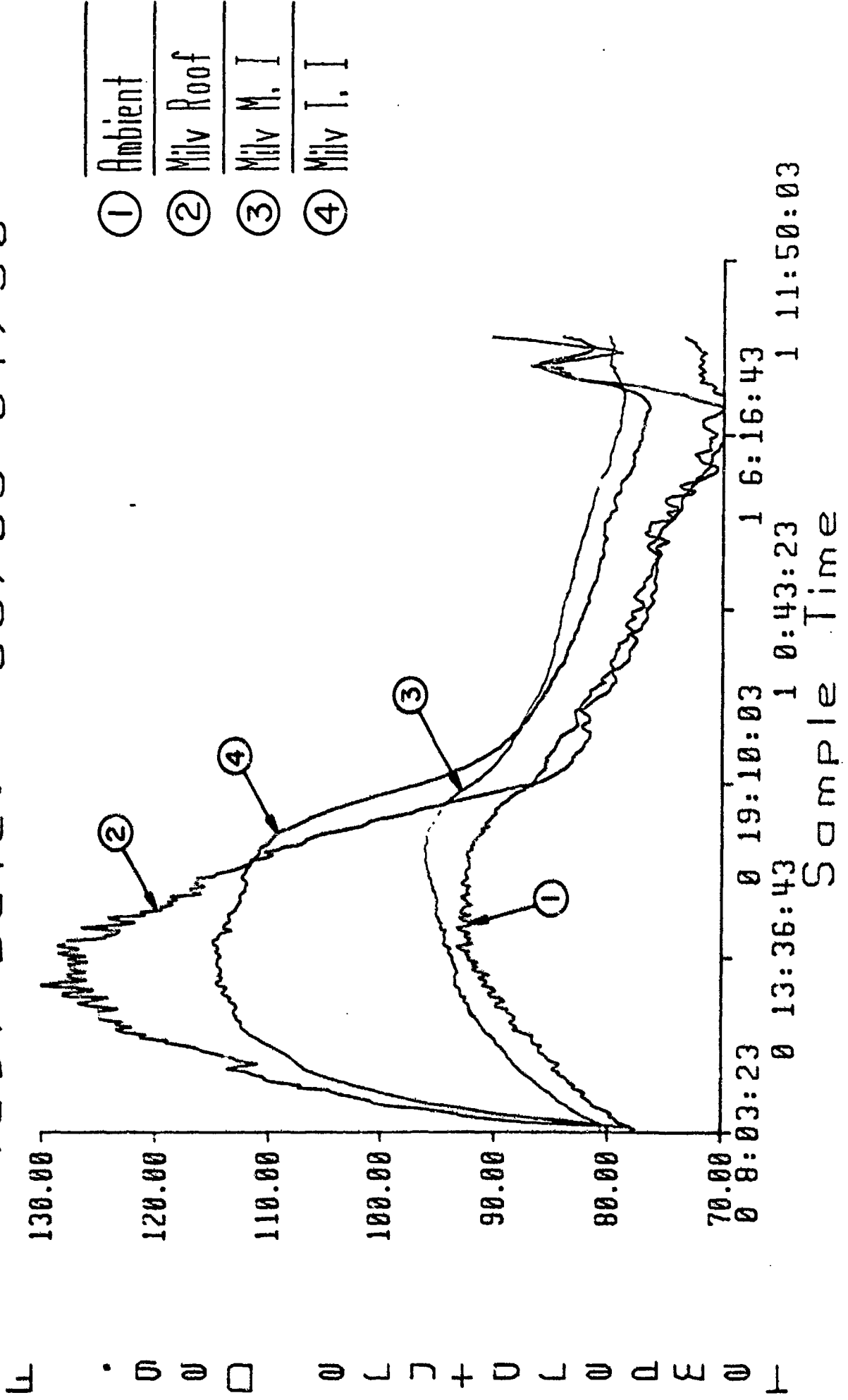

Solar Shield Test

Test Date: 09/10-11/90

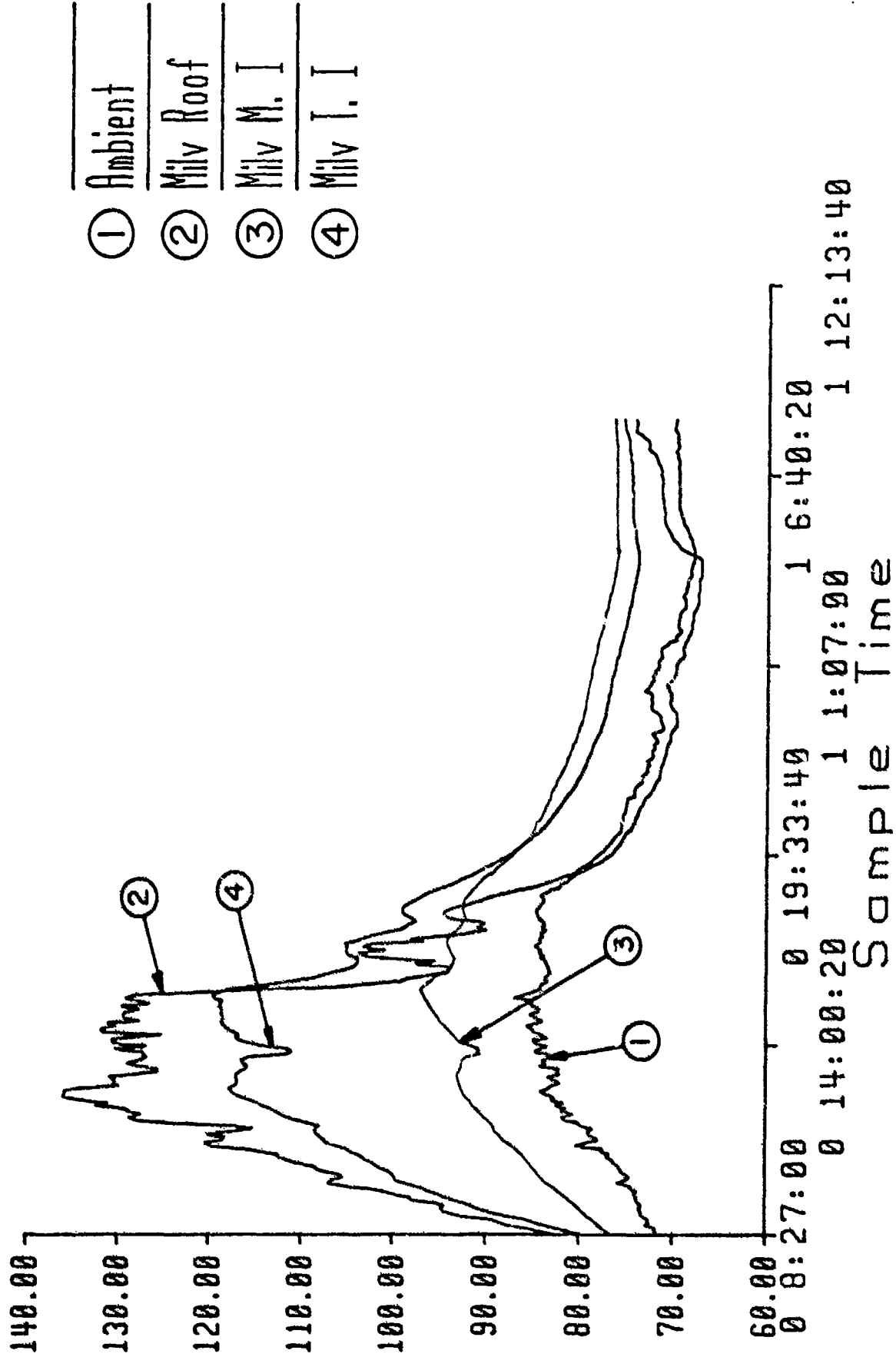

Solar Shield Test

Test Date: 09/12-13/90

U
C
·
00
00
□
0
L
L
J
+
D
L
0
0
>
Σ
0
Σ
U

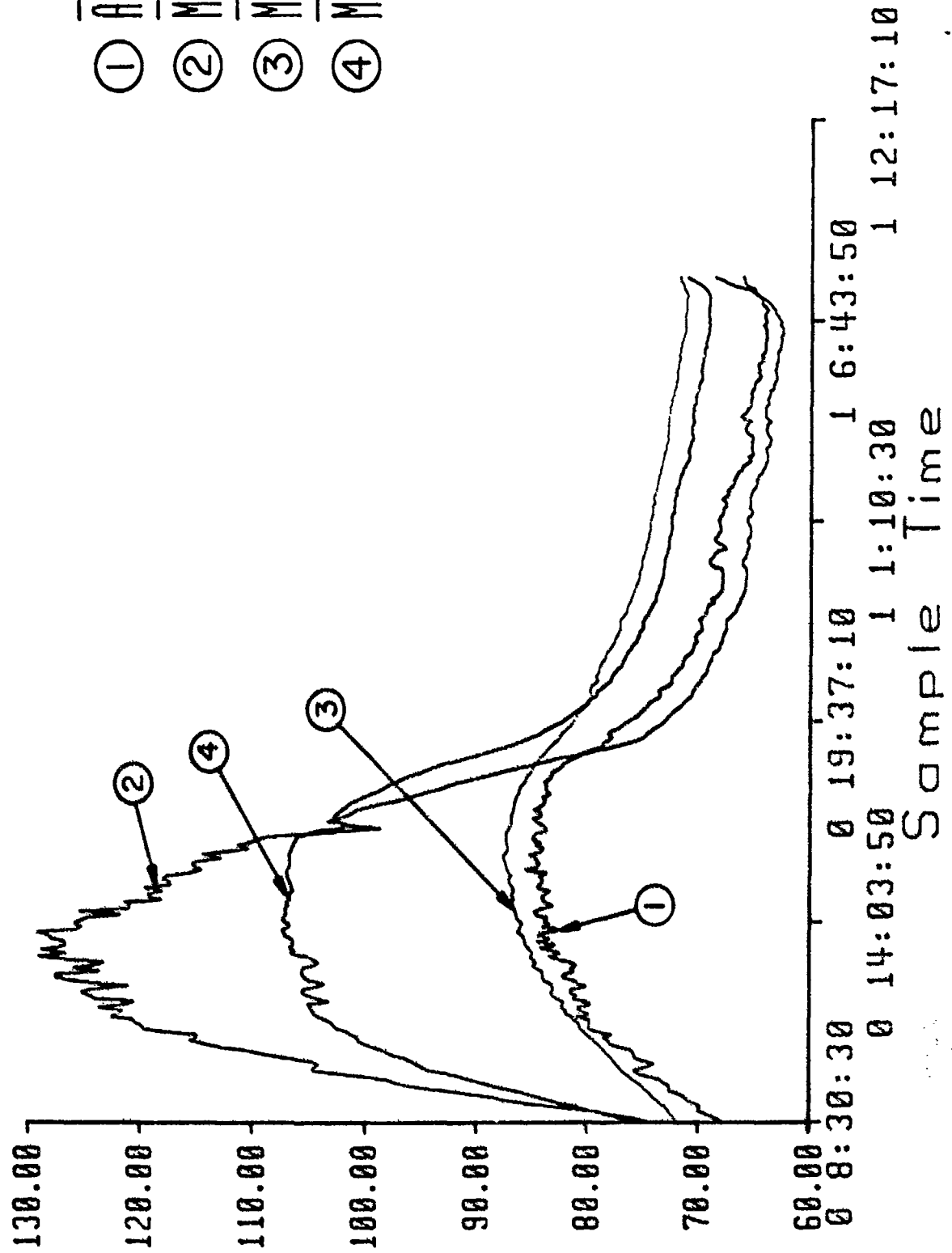

Test Solar Shield Test
Date: 08/23-24/90

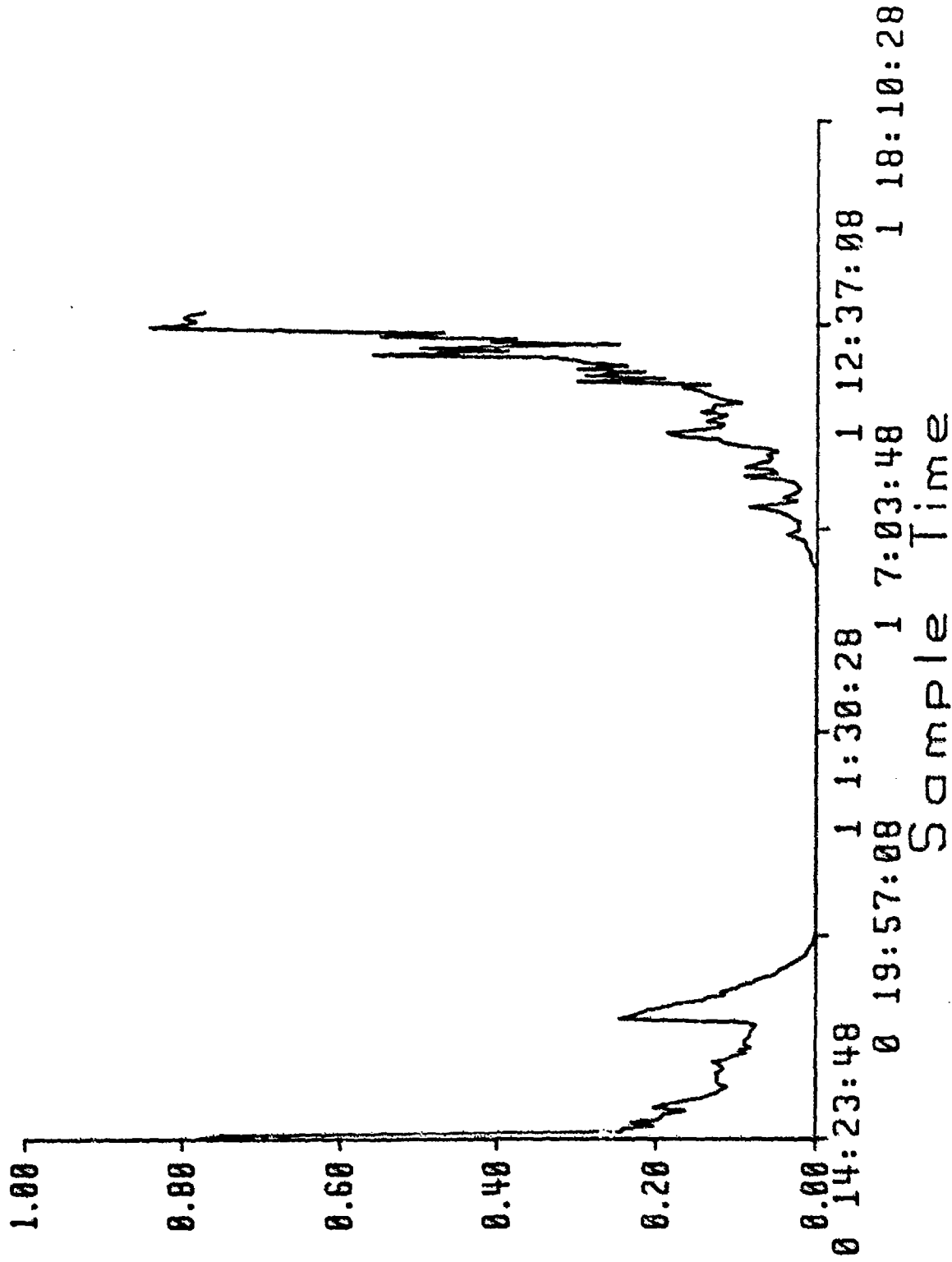

GRAPH NO. 22

Solar Shield Test

Test Date: 08/24-27/90

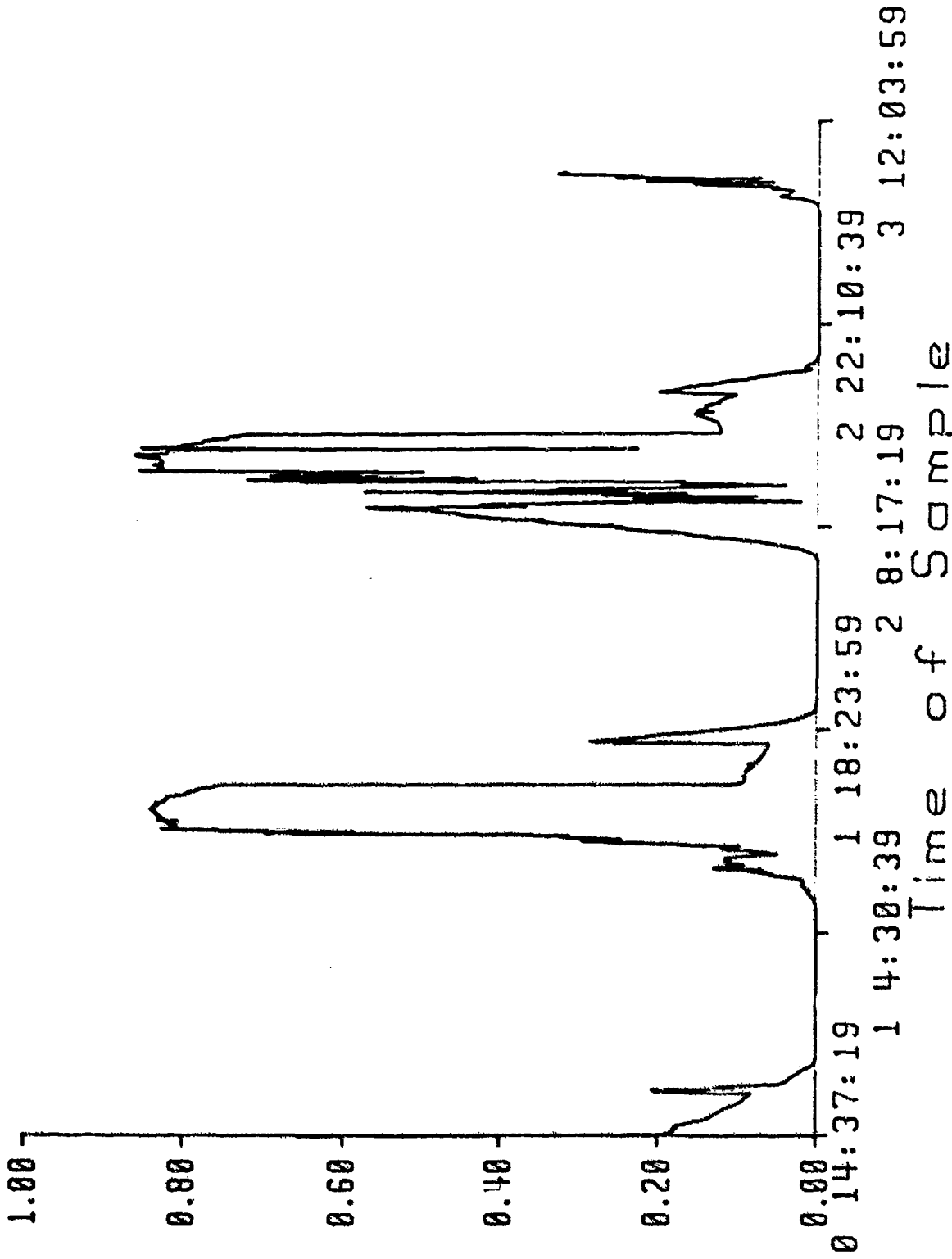

GRAPH NO. 23

Solar Shield Test
Test Date: 08/29-30/90

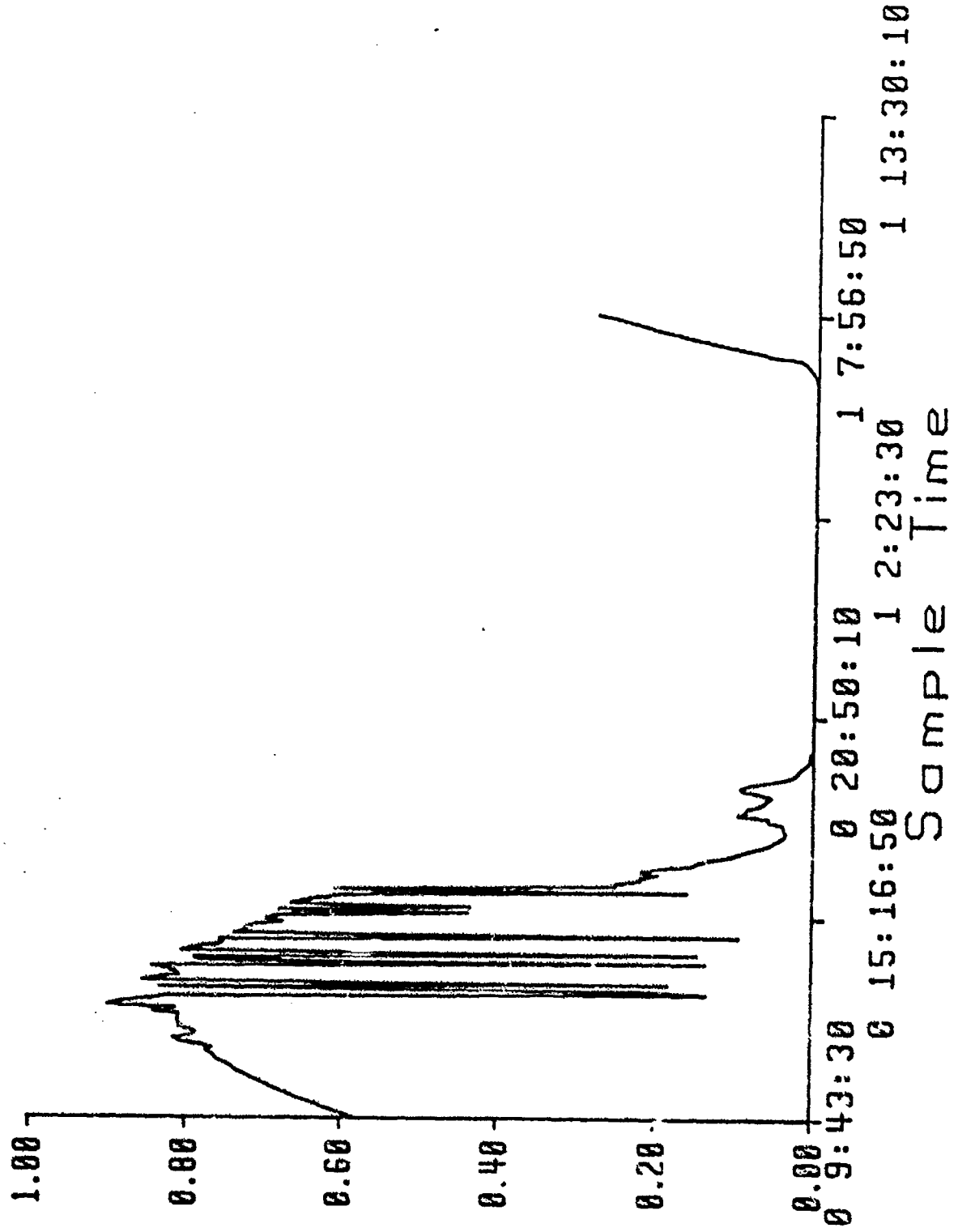

Solar Shield Test
Test Date: 08/30-31/90

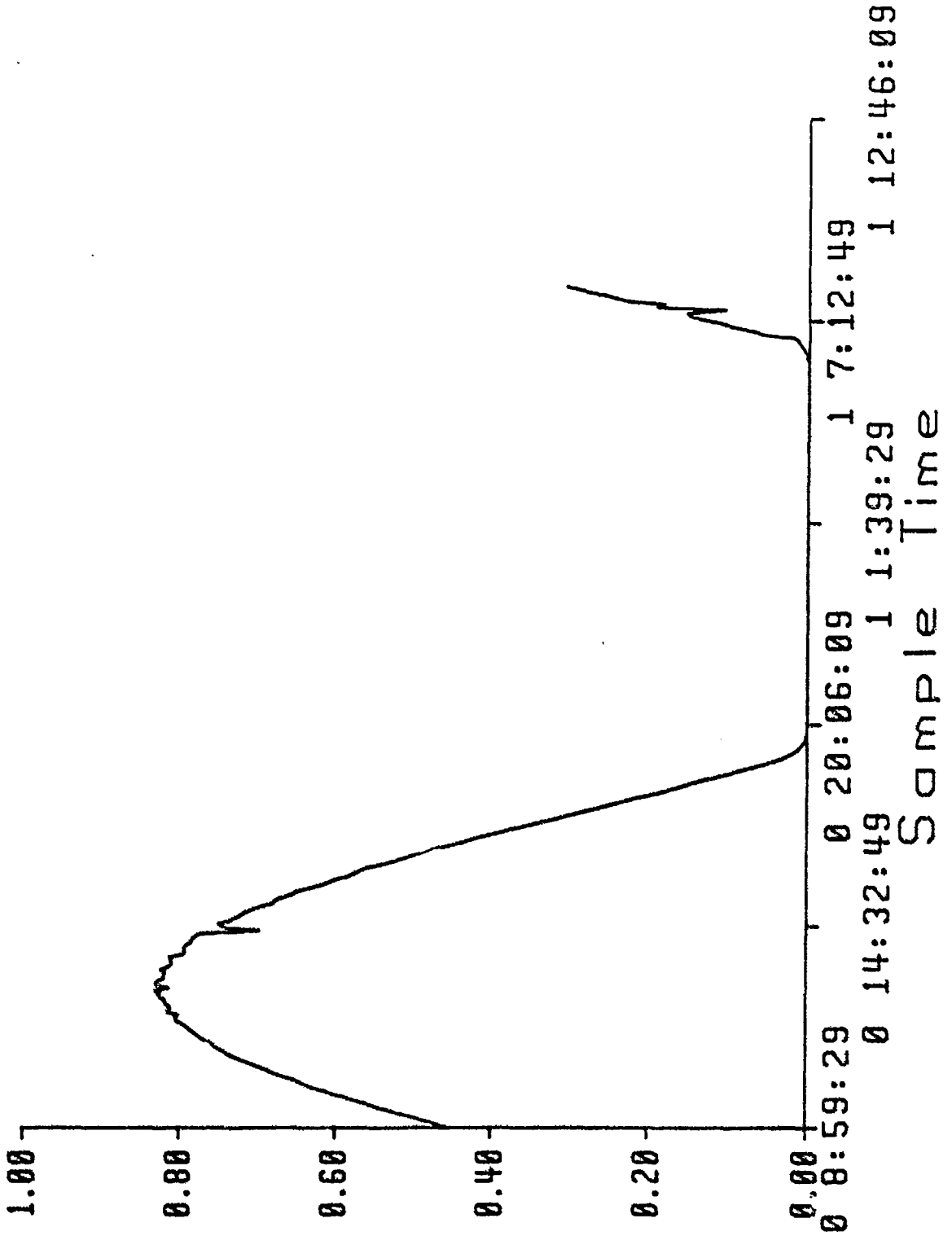

U
S
W / M
P
D
R
L
D
-
O
S

Test Solar Shield Test
Date: 09/04-05/90

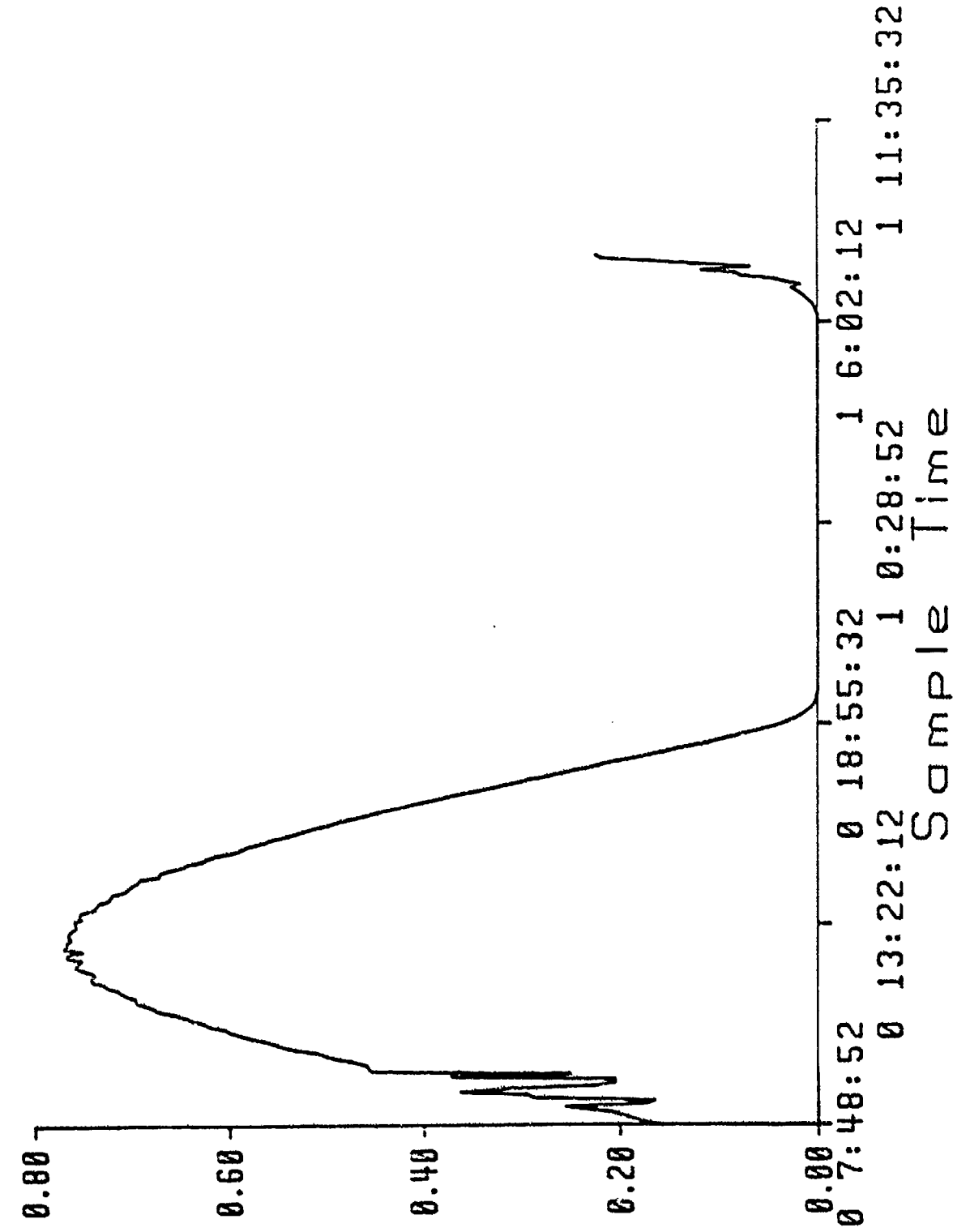

Solar Shield Test

Test Date: 09/05-06/90

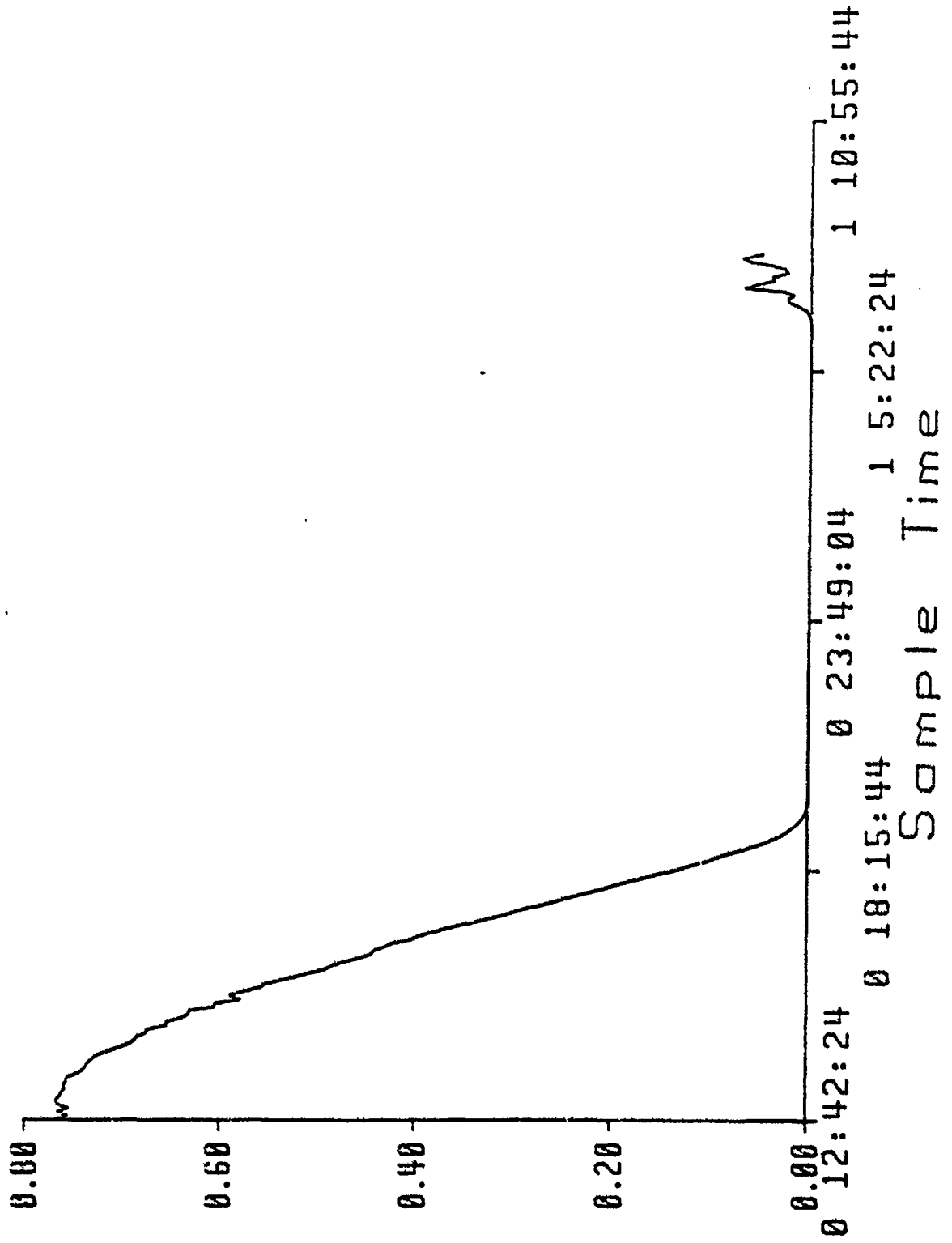

Test Solar Shield Test
Date: 09/06-07/90

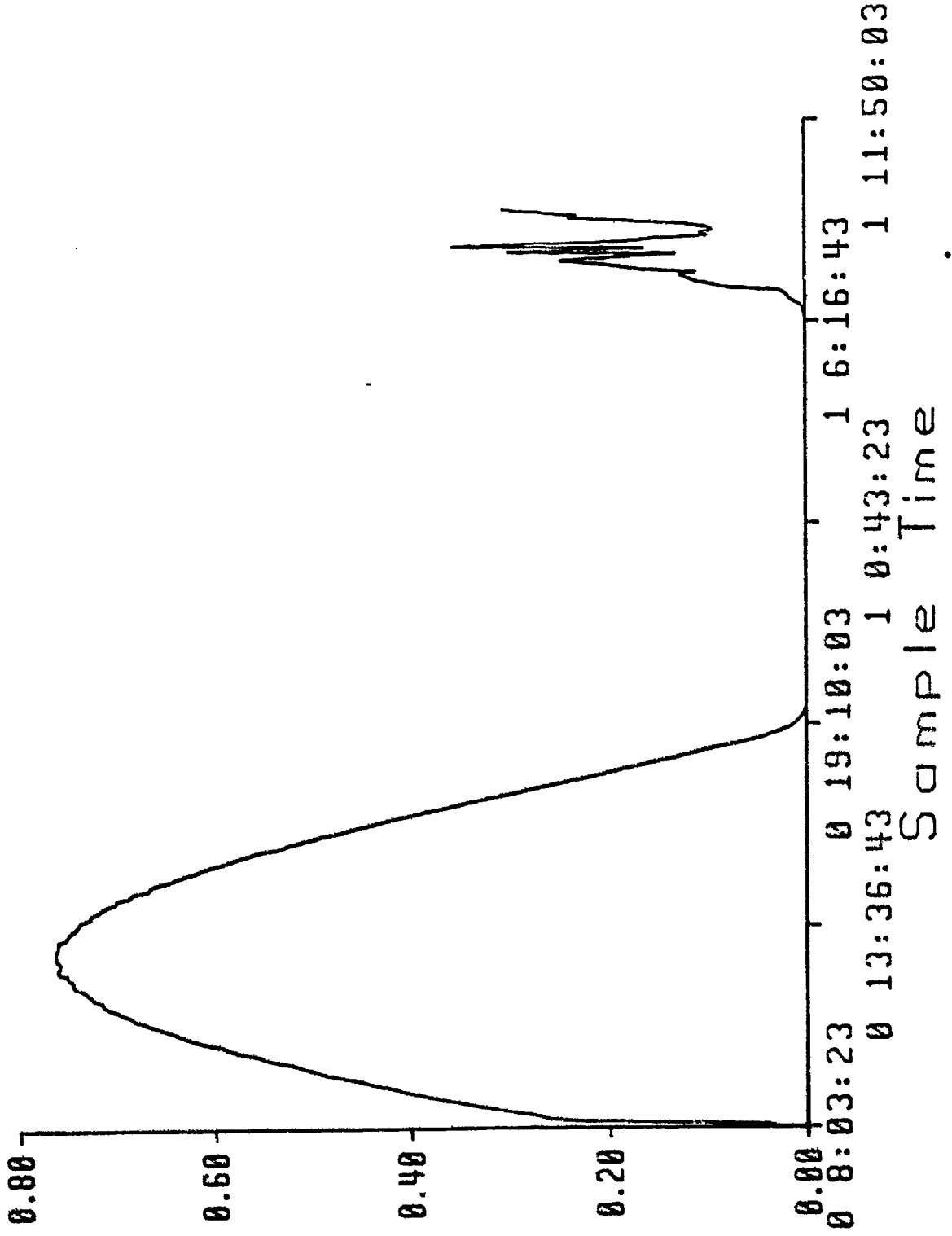

GRAPH NO. 29

Solar Shield Test
Test Date: 09/07/90

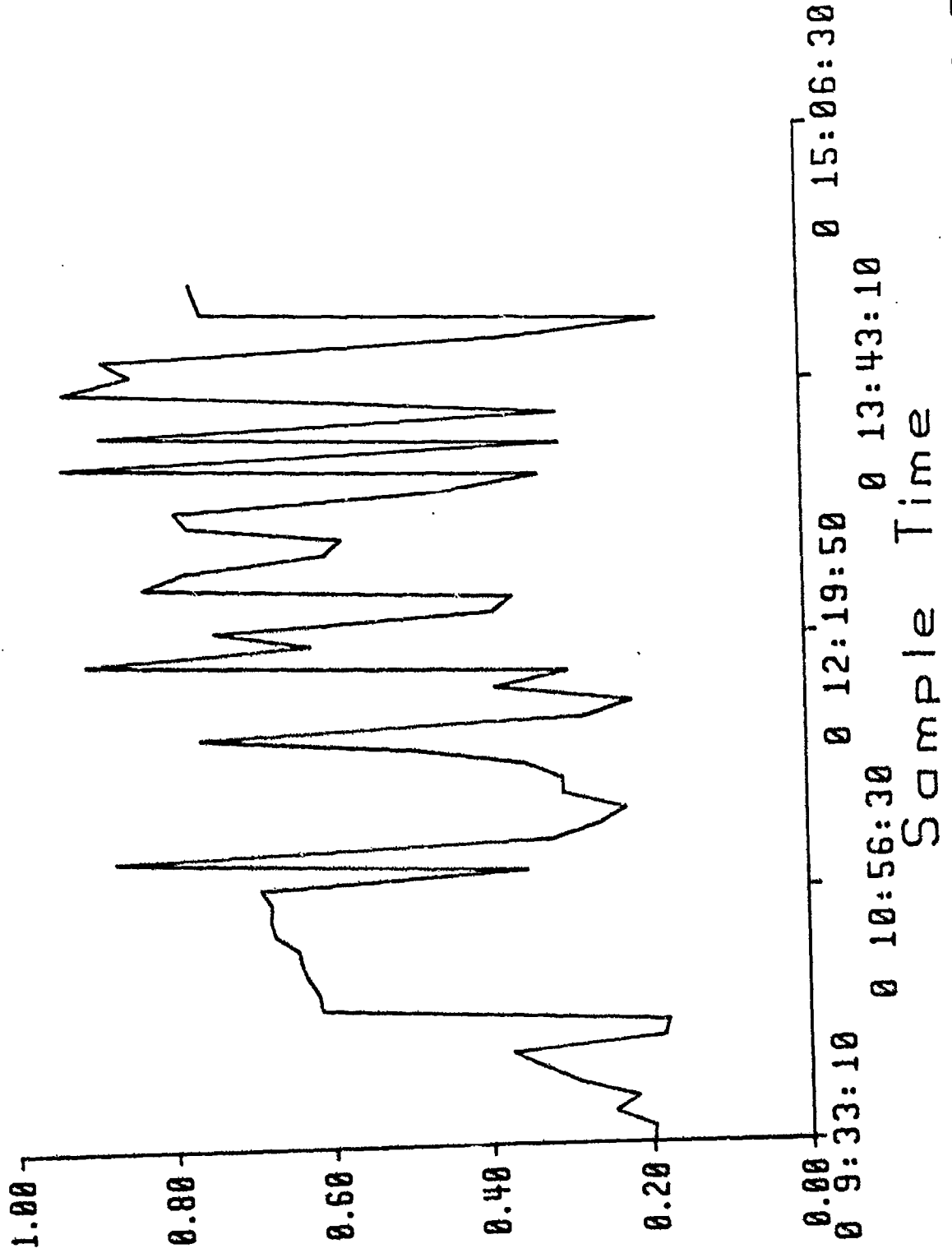

Solar Shield Test

Test Date: 09/07-10/90

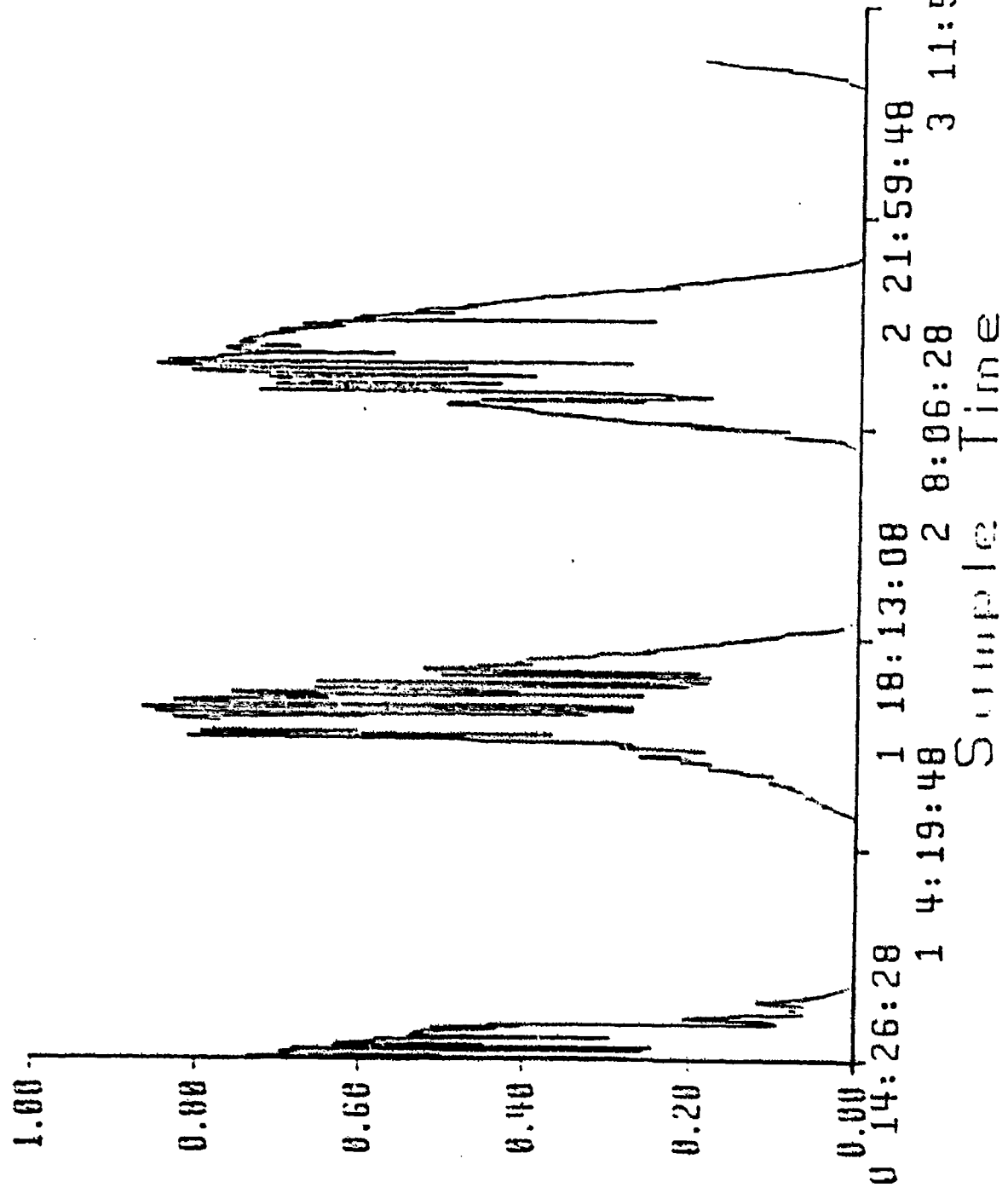

S O I O J P O R P O M / M X S .

Solar Shield Test

Test Date: 09/10-11/90

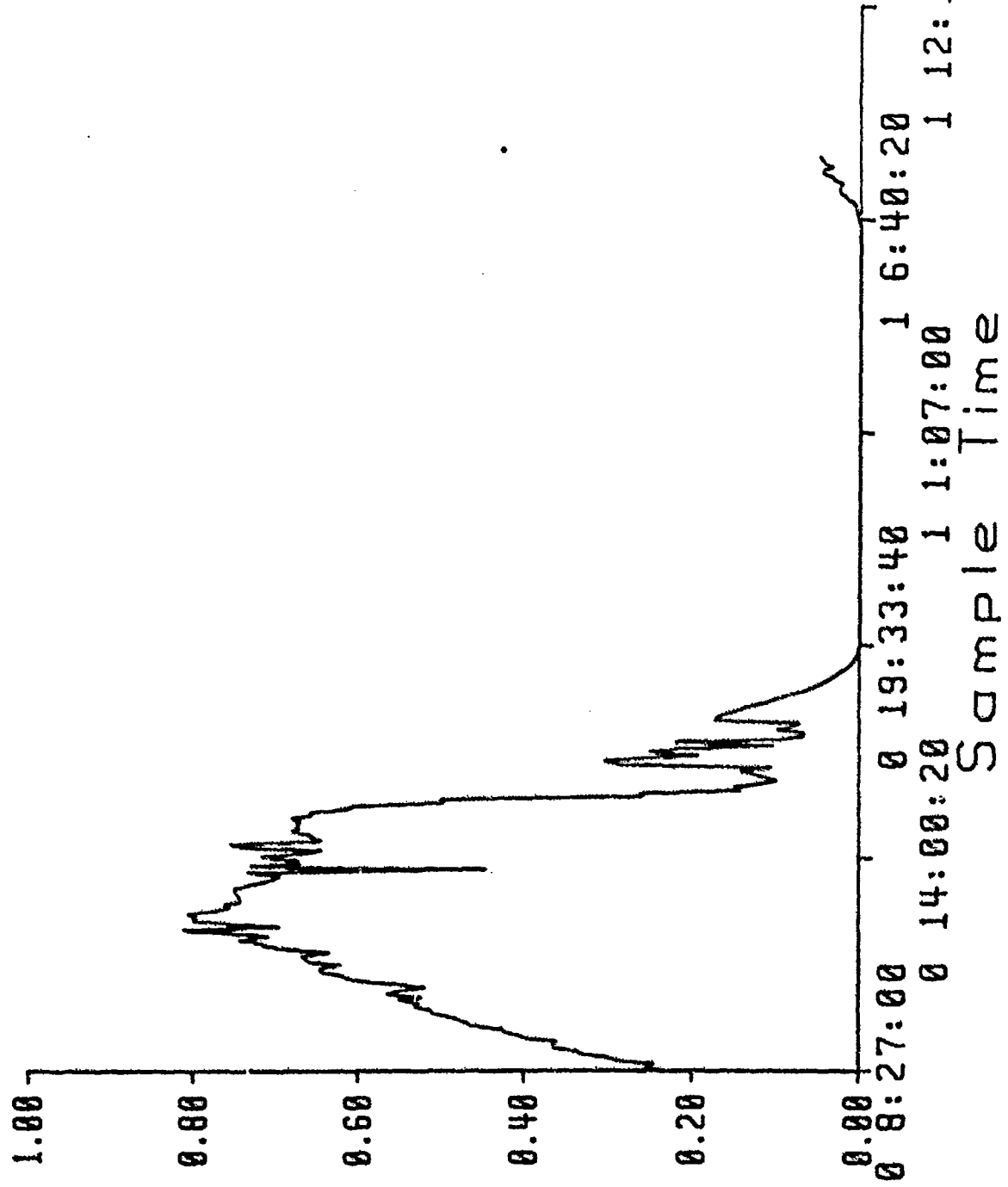

GRAPH NO. 32

Solar Shield Test
Test Date: 09/11/90

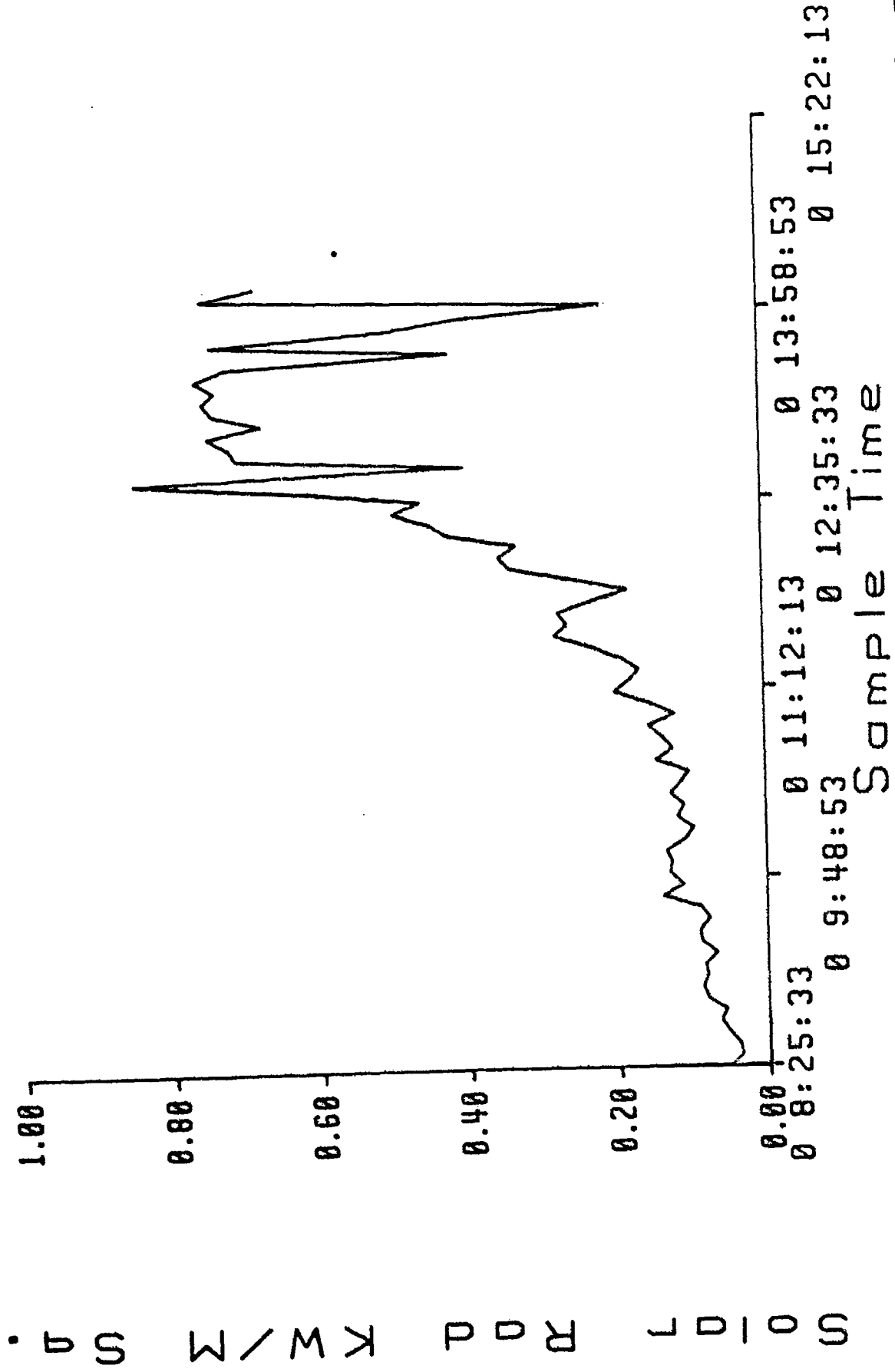

GRAPH NO. 33

Solar Shield Test

Test Date: 09/11-12/90

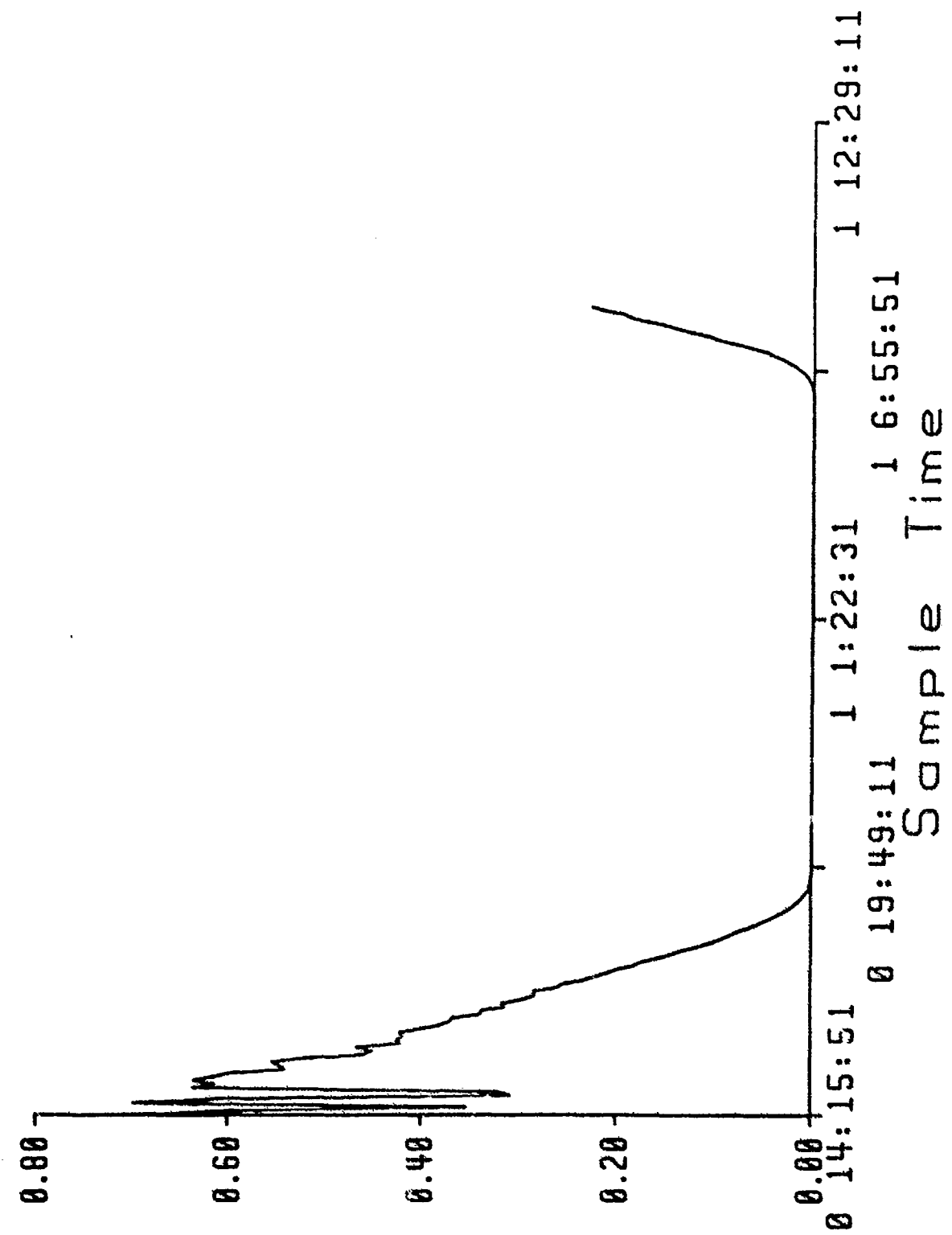

S W/M V P D R L O U

Solar Shield Test

Test Date: 09/12-13/90

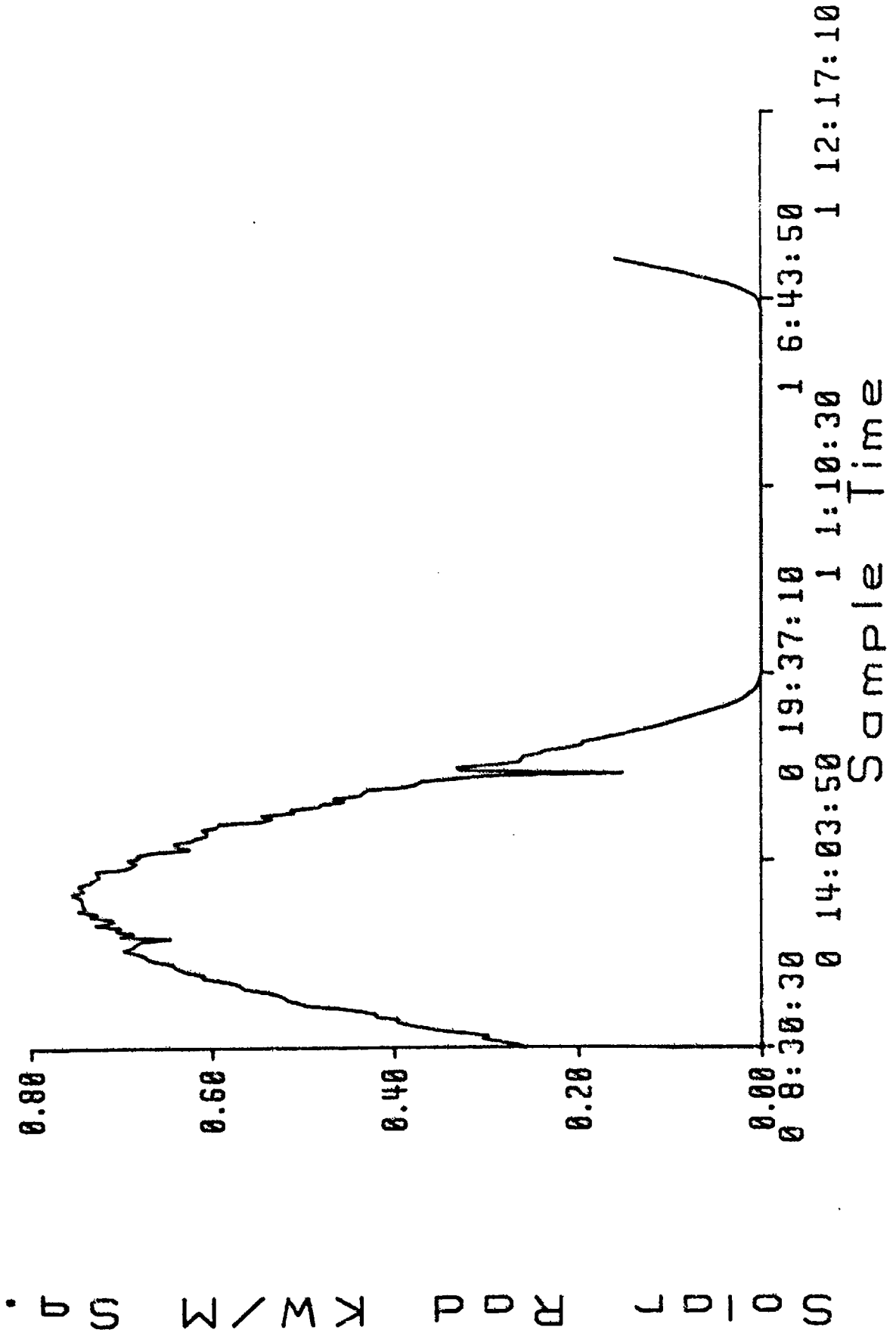

Solar Shield Test

Test Date: 09/13-14/90

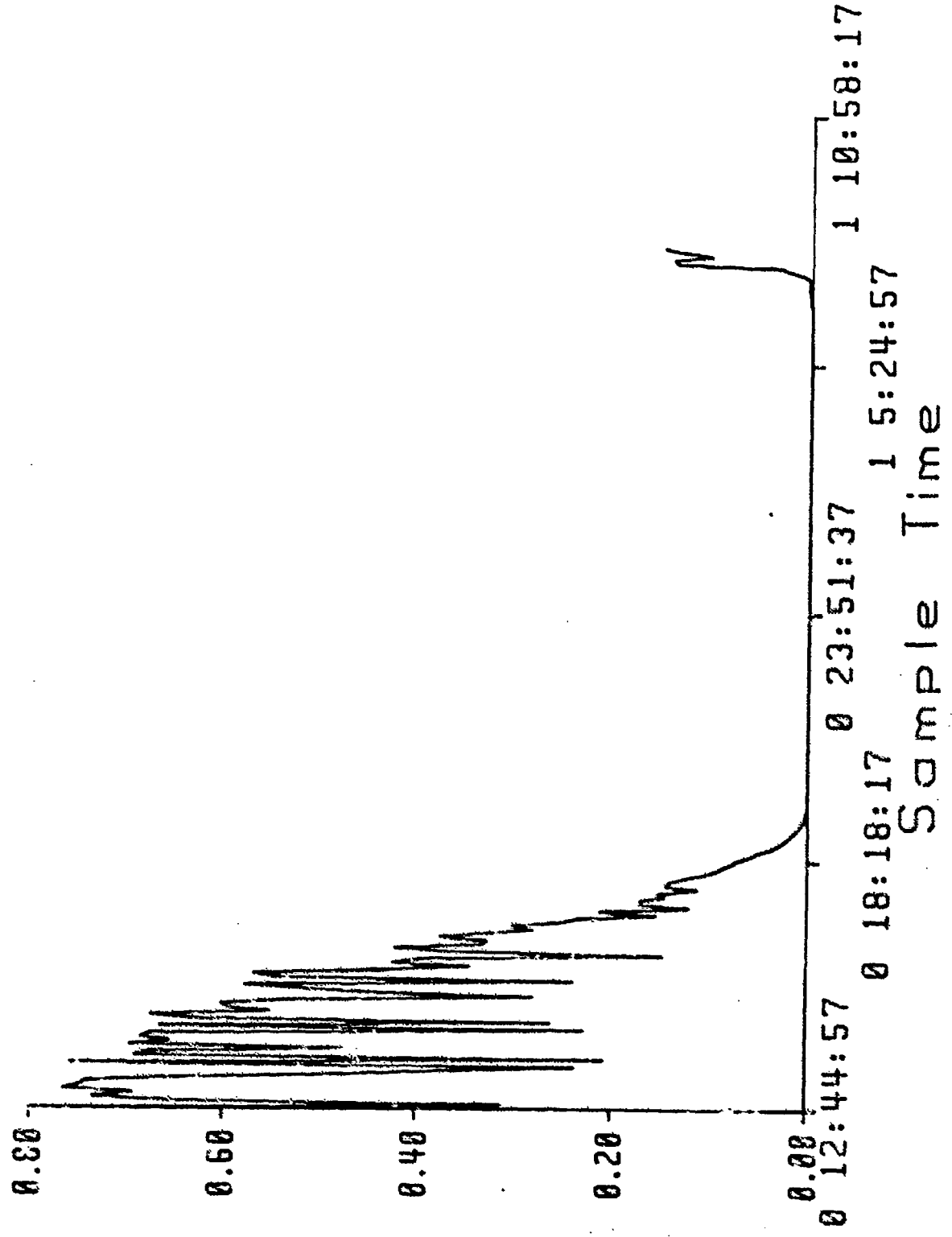

0 - 0 7
R D
P D
K W / M
S D

