

AD-A247 015



Report No. NADC-91038-60

2



HUMAN FACTORS ENGINEERING TOOL EVALUATION - TECHNICAL APPROACH & PROGRAM PLAN

Joseph Kern
Air Vehicle and Crew Systems Technology Department (Code 6022)
NAVAL AIR DEVELOPMENT CENTER
Warminster, PA 18974-5000

Judith Lind
Aircraft Weapons Integration Department
NAVAL WEAPONS CENTER
China Lake, CA 93555-6001

30 SEPTEMBER 1990

FINAL REPORT
Task No. W0542001
Work Unit No. 481706
Program Element No. 63701N
Project No. W0542

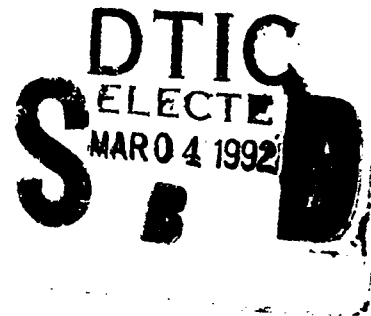

Approved for Public Release; Distribution is Unlimited

Prepared for
NAVAL AIR SYSTEMS COMMAND (AIR-933)
Washington, DC 20361-0001

92-05152



NOTICES

REPORT NUMBERING SYSTEM — The numbering of technical project reports issued by the Naval Air Development Center is arranged for specific identification purposes. Each number consists of the Center acronym, the calendar year in which the number was assigned, the sequence number of the report within the specific calendar year, and the official 2-digit correspondence code of the Command Officer or the Functional Department responsible for the report. For example: Report No. NADC-88020-60 indicates the twentieth Center report for the year 1988 and prepared by the Air Vehicle and Crew Systems Technology Department. The numerical codes are as follows:

CODE	OFFICE OR DEPARTMENT
00	Commander, Naval Air Development Center
01	Technical Director, Naval Air Development Center
05	Computer Department
10	AntiSubmarine Warfare Systems Department
20	Tactical Air Systems Department
30	Warfare Systems Analysis Department
40	Communication Navigation Technology Department
50	Mission Avionics Technology Department
60	Air Vehicle & Crew Systems Technology Department
70	Systems & Software Technology Department
80	Engineering Support Group
90	Test & Evaluation Group

PRODUCT ENDORSEMENT — The discussion or instructions concerning commercial products herein do not constitute an endorsement by the Government nor do they convey or imply the license or right to use such products.

Reviewed By: *Leann Kuppel* Date: *11/22/91*
Branch Head

Reviewed By: *S M Mitchell* Date: *11/27/91*
Division Head

Reviewed By: *J H Frae* Date: *9 Dec 91*
Director/Deputy Director

REPORT DOCUMENTATION PAGE

1a REPORT SECURITY CLASSIFICATION UNCLASSIFIED			1b RESTRICTIVE MARKINGS			
2a SECURITY CLASSIFICATION AUTHORITY			3 DISTRIBUTION AVAILABILITY OF REPORT Approved for Public Release; Distribution is Unlimited			
2b DECLASSIFICATION/DOWNGRADING SCHEDULE						
4 PERFORMING ORGANIZATION REPORT NUMBER(S) NADC-91038-60			5 MONITORING ORGANIZATION REPORT NUMBER(S)			
6a NAME OF PERFORMING ORGANIZATION Air Vehicle and Crew Systems Technology Department		6b OFFICE SYMBOL (If applicable) Code 6022	7a NAME OF MONITORING ORGANIZATION Air Vehicle and Crew Systems Technology Department (Code 60B5)			
6c ADDRESS (City, State, and ZIP Code) NAVAL AIR DEVELOPMENT CENTER Warminster, PA 18974-5000			7b ADDRESS (City, State, and ZIP Code) Naval Air Development Center Warminster, PA 18974-5000			
8a NAME OF FUNDING/SPONSORING ORGANIZATION NAVAL AIR SYSTEMS COMMAND		8b OFFICE SYMBOL (If applicable) AIR-933	9. PROCUREMENT INSTRUMENT IDENTIFICATION NUMBER			
8c ADDRESS (City, State, and ZIP Code) Washington, DC 20361-0001			10. SOURCE OF FUNDING NUMBERS			
		PROGRAM ELEMENT NO. 63701N	PROJECT NO. W0542	TASK NO. W0542001	WORK UNIT ACCESSION NO. 481706	
11 TITLE (Include Security Classification) Human Factors Engineering Tool Evaluation - Technical Approach and Program Plan						
12 PERSONAL AUTHOR(S) Kern, Joseph E.*, Lind, Judith H.**						
13a TYPE OF REPORT Final		13b TIME COVERED FROM _____ TO _____		14 DATE OF REPORT (Year, Month, Day) 1990 September 30		15 PAGE COUNT
16 SUPPLEMENTARY NOTATION * See Reverse Side						
17 COSATI CODES			18 SUBJECT TERMS (Continue on reverse if necessary and identify by block number)			
FIELD 23	GROUP 02	SUB-GROUP	Crew Stations, Design, Development, Evaluation, Human Factors, Methodologies, Procedures, Taxonomy, Techniques, Tools, Validation, Weapon System Acquisition			
19 ABSTRACT (Continue on reverse if necessary and identify by block number) This document describes the results of Phase 1 of a multi-year program intended to identify and validate tools and techniques that can be used to assist human factors engineering (HFE) practitioners during the military's normal weapon system acquisition process. Once validated, the tools will be supplied to U.S. Navy laboratories where HFE practitioners can benefit from the assistance of these tools. A detailed literature review was conducted to obtain data from previous surveys of HFE tools and information on how such tools may be evaluated and validated. A HFE Procedures Taxonomy was developed to categorize the various tools. This Taxonomy was based on: (1) five weapon system acquisition phases, (2) 115 HFE procedures or tasks commonly carried out during these phases, and (3) various attributes of the procedures and tools. Tool types recommended for further evaluation and validation are described, and the validation process is described.						
20 DISTRIBUTION AVAILABILITY OF ABSTRACT <input type="checkbox"/> UNCLASSIFIED UNLIMITED <input checked="" type="checkbox"/> SAME AS RPT <input type="checkbox"/> DTIC USERS			21 ABSTRACT SECURITY CLASSIFICATION UNCLASSIFIED			
22a NAME OF RESPONSIBLE INDIVIDUAL JOSEPH E. KERN			22b TELEPHONE (Include Area Code) (215) 441-2902		22c OFFICE SYMBOL 6022	

Block 16

Joseph Kern*
Air Vehicle and Crew Systems Technology Department (Code 6022)
NAVAL AIR DEVELOPMENT CENTER
Warminster, PA 18974-5000

Judith Lind**
Aircraft Weapons Integration Department
NAVAL WEAPONS CENTER
China Lake, CA 93555-6001

CONTENTS

	Page
FIGURES.....	ii
ABSTRACT.....	iii
INTRODUCTION.....	1
RESULTS OF THE LITERATURE REVIEW.....	8
DEVELOPMENT OF AN HFE TOOL TAXONOMY.....	19
EVALUATION AND VALIDATION OF TOOLS.....	31
SUMMARY.....	36
REFERENCES.....	38
APPENDIX	
A HFE Tools Taxonomy.....	A-1
B Tool Types And The HFE Tasks That They Support.....	B-1



Accession For	
NTIS GRA&I	<input checked="" type="checkbox"/>
DTIC TAB	<input type="checkbox"/>
Unannounced	<input type="checkbox"/>
Justification	
B:	
Distribution/	
Availability Codes	
Dist	Avail and/or Special
A-1	

FIGURES

Figure	Page
1 Human Factors Engineering Tool Evaluation.....6 Project Organization	6
2 Human Factors Engineering Tool Evaluation -7 Tasks and Milestones	7
3 Human Factors Engineering Product, Action, and.....21 Procedures Related to the Mission Analysis Phase of the Weapon System Acquisition Cycle, Prior to Milestone 0	21
4 Human Factors Engineering Product, Action, and.....21 Procedures Related to the Concept Development Phase of the Weapon System Acquisition Cycle, Prior to Milestone 1	21
5 Human Factors Engineering Product, Action, and.....22 Procedures Related to the Demonstration and Validation Phase of the Weapon System Acquisition Cycle, Prior to Milestone 2	22
6 Human Factors Engineering Product, Action, and.....22 Procedures Related to the Full-Scale Development Phase of the Weapon System Acquisition Cycle, Prior to Milestone 3	22
7 Human Factors Engineering Product, Action, and.....23 Procedures Related to the Production and Deployment Phase of the Weapon System Acquisition Cycle, Following Milestone 3	23
8 Relationship of Human Factors Engineering.....23 Procedures and Weapon System Acquisition Phases to the HFE Taxonomy	23
9 Overall Design of the HFE Tool Taxonomy Developed.....24 for this Study, Including Attributes of HFE Procedures and HFE Tools	24

ABSTRACT

This document describes the results of Phase 1 of a multi-year program intended to identify and validate tools and techniques that can be used to assist human factors engineering (HFE) practitioners during the military's normal weapon system acquisition process. Once validated, the tools will be supplied to U.S. Navy laboratories where HFE practitioners can benefit from the assistance of these tools. A detailed literature review was conducted to obtain data from previous surveys of HFE tools and information on how such tools may be evaluated and validated. A HFE Tool Taxonomy was developed to categorize the various tools. This Taxonomy was based on: (1) five weapon system acquisition phases, (2) 115 HFE procedures or tasks commonly carried out during these phases, and (3) various attributes of the procedures and tools. Tool types recommended for further evaluation and validation are described, and the validation process is described.

KEYWORDS

Cockpits
Computer aiding
Computerized tools
Crew stations
Design
Development
Evaluation
Human-computer interaction
Human factors
Man-machine interfaces
Methodologies
Procedures
Taxonomy
Techniques
Tools
Validation
Weapon system acquisition

INTRODUCTION

HUMAN FACTORS ENGINEERING FOR MILITARY SYSTEMS

The traditional methodology of Human Factors Engineering (HFE) is used during various aspects of the military aircraft/weapon system development process. From concept definition of a new system through engineering development and testing, HFE techniques can help define the evolving interface between the human element and the system. In addition, Naval Air Systems Command Instruction 3900.10 (15 January 1986) mandates that "When humans are components of any system or operate or maintain equipment covered by this instruction [all phases of all system and equipment acquisitions, improvements, production, and support], principles and practices of human engineering shall be used to define human functions and the means to accomplish them."

In the past, the use of HFE methods and procedures has not always been systematic. This is generally true for both in-house Navy efforts and for contractor efforts. In addition, few of the "tools of the trade" used for HFE analysis, design, and test have been validated in a laboratory setting or field tested. Some tools have been developed because of the personal interest of the developer rather than the appropriateness of the tool to fulfill a specific need.

For purposes of this study, the following definition has been used.

"A HFE tool is something used in performing an operation, task, or procedure necessary in the practice of Human Factors Engineering. A tool may take the form of a software program, a paper and pencil technique, or a documented procedure or method. It may be government owned or commercially available."

Categories of tools other than software are included so that other techniques (e.g., paper and pencil) with a high value to the HFE profession are not arbitrarily excluded. Valuable tools, other than software, could become candidates for computerization to make them more functional.

In order to be effective, HFE procedures and tools must be used properly and applied to an appropriate phase of the aircraft or weapon system development. Additionally, for HFE groups within the Navy to communicate effectively, a consensus should be reached on the use of tools. This consensus should include, as a minimum,

1. What tools are to be used,
2. When these tools are to be used, and
3. How the outputs of these tools are to be used.

The Navy needs an evaluation framework and a standardized methodology both for evaluating existing tools and for developing new tools. A proven method is urgently required to meet both present and future needs.

PROBLEMS WITH HFE TOOLS

Limited Use of Tools

Human Factors technology development has traditionally involved creating new methodologies to model various aspects of the human component in complex weapon systems. The human models primarily address cognitive processing, visual processing, and physical attributes. These development efforts have recently resulted in numerous software packages that use traditional data as inputs to an algorithmic process.

There has been a proliferation of software tools that have undergone extensive development efforts but have never emerged from the laboratory. Tools that have emerged and have been put to practical use have not been widely used by a substantial portion of the practitioners in the field of HFE. Fleger and others (1987) surveyed the software tools available to the Human Engineering industry during 1986 and 1987. They have reported that the use of automated aids is not widespread among Human Engineering specialists within government and industry.

Why would someone working in a highly dynamic field fail to take advantage of an automated tool? In general, HFE tools have proven to be

1. Unknown, that is, HFE practitioners do not know that the tools exist or the tools intended purpose.
2. Costly, due primarily to the hardware, software, and support personnel required.
3. Time consuming to use, requiring as much time and effort as traditional methods.
4. Training intensive, requiring specialized courses and frequent use to maintain proficiency.
5. Easy to forget, requiring frequent relearning, since HFE practitioners carry out each specific type of procedure or task (such as workload analysis) infrequently.
6. Unreliable, since the output cannot be independently verified.
7. Unavailable, since automated tools applicable throughout the Department of Defense (DOD) sometimes have remained within the province of a single service (e.g., the Air Force).

Standardization of tools would theoretically help to control the cost of tool acquisition and the cost of training. As a particular tool was used over a period of time, the repeated usage would provide a means to assess reliability. The amount of time required to use a tool would also become less of a problem as the proficiency of the users increased. A related factor, timing, is using a tool at the proper time in the development schedule. With better anticipation of the need (i.e., a scheduled time for application of the tool), valuable lead time could be

gained. The time required to use the tool effectively can be spread out on the front end of the process.

Inappropriate Use of Tools

The problem of not using potentially valuable tools is compounded when tools are used, but not used appropriately. Inappropriate uses of HFE tools can be placed in three categories.

1. Tools have been used at inappropriate times in the weapon system development process (i.e., too early or too late to affect design decisions).
2. Tools have been used at appropriate times but their outputs have been misapplied when decisions were made concerning operator or maintainer equipment.
3. Tools have been used for purposes for which they were not intended, such as for proving compliance with design requirements "by analysis" in place of a formalized demonstration or test, or for some application for which the tool was not designed.

Lack of Tool Validation

Some tools are used even though their outputs have not been validated. Properly designed and executed validation studies point out deficiencies if these exist. But validation often is considered an unacceptable expense following the cost of developing the tool. Lack of validation continues to undermine the effective use of tools by the Human Engineering profession.

ASSUMPTIONS

This investigation did not initially assume that new tools must be developed to enhance the working climate of the Human Engineering specialist. Rather, it was assumed that tools with potential value are available now or are currently under development and in a form suitable for evaluation. The potential value of a tool will be tied to Human Engineering tasks associated with the weapons system acquisition cycle. The assumptions for this project include the following.

1. Useful tools for crew station analysis, design, and evaluation are needed to achieve effective crew station integration.
2. A variety of potentially useful crew station analysis, design, and evaluation tools currently exist or are under development.
3. Assessment of specific tool utility and validation has been minimal, so far.

NADC-91038-60

GOAL AND OBJECTIVES

The goal of this study is to initiate a multi-year program that will result in a set of systematic procedures for ensuring that HFE techniques are properly applied to military systems, with emphasis on Naval aircraft crew stations. With the above assumptions in mind, this goal will be met by identifying and validating HFE tools which Navy Human Engineering practitioners can use for carrying out established HFE tasks and procedures. These tools then will be provided to the Navy Laboratories for use by HFE practitioners during the weapon system acquisition cycle.

As noted above, what tools are to be used, when to use them, and how to use the outputs must be specified. A tool validation framework and standardized methodology must be provided through this program. The end result will be tools that aid in development of military aircraft and weapon systems--systems that can be operated and maintained by military personnel rapidly, accurately, safely, with ease, and with satisfaction.

In order to meet this goal, the overall program effort has been divided into two phases. Several objectives have been identified for the first phase (6.3 Advanced Development Level).

1. Determine and document the various kinds of tasks and procedures commonly carried out by HFE practitioners at the Navy Laboratories to support crew station development.
2. Categorize these tasks and procedures according to the phase of the military weapon system acquisition cycle in which they normally are applied.
3. Identify and describe valid, existing HFE analysis, design, and evaluation tools.
4. Based on the phases of the military acquisition cycle and the HFE tasks and procedures carried out during each phase (Objective 2), develop an appropriate taxonomy that can be used to categorize and to compare the identified HFE tools.
5. Develop methodologies that can be used first to evaluate (through analysis) the utility of the identified tools and then formally to validate (through testing) the best tool candidates, for use in each of the HFE task categories.
6. Evaluate and compare the identified existing HFE tools and select the most promising for acquisition and formal validation.
7. Identify those significant HFE tasks and procedures for which no promising tool currently exists or is under development, and determine whether a tool is necessary for optimum human engineering of military systems.

NADC-91038-60

8. Determine when, where, and by whom formal validations (Objectives 5 and 6) will be carried out for existing tools identified as promising candidates.

Once the first phase is complete, the second phase (6.4 Full-Scale Development Level) will begin. Objectives for this level include the following.

1. Obtain the promising HFE tools identified in Objective 6 of Phase I, and conduct formal validations of them, using the validation methodology developed in Objective 5. Identify the one (or perhaps two or three) best tools for each of the HFE tasks or procedures.
2. Develop new HFE tools for those Human Engineering tasks identified in Objective 7 of Phase I as requiring such tools but for which tools are not now available.
3. Identify various sets of validated tools that can be included in "tool kits," each kit containing those specific kinds of HFE tools needed by Human Engineering practitioners at each of the Navy Laboratories. "Tool kit" components will be based on the Laboratory's mission and on the kinds of HFE tasks and procedures carried out (as determined in Objective 1, Phase I).
4. Provide each Navy Laboratory with the appropriate "tool kit" and the training necessary to ensure that HFE personnel learn to use the tools effectively.

APPROACH

In order to involve all of the intended Laboratory user groups on the front end of this process, a multi-Laboratory team approach has been initiated. This team consists of Human Engineering representatives from the Naval Air Development Center (NADC), the Naval Weapons Center (NWC), and the Naval Air Test Center (NATC). These representatives will be involved in the review, evaluation, and transition of tools for crew station analysis, design, and test. The team will work towards devising a common methodology to select and evaluate these tools, to ensure end user acceptance of the resulting "tool kits."

The elements of the project organization include the following.

1. Sponsors - 6.3 - NAVAIRSYSCOM (CDR S. Harris)
6.4 - NAVAIRSYSCOM (PMA 202)
2. Management - Naval Air Development Center
(Dr. N. Warner Code 60B5)
3. Performing Organizations
 - a. Naval Air Development Center (Code 6022)
 - b. Naval Weapons Center (Code 3152)
 - c. Naval Air Test Center (SY-72)

This organization is depicted by Figure 1.

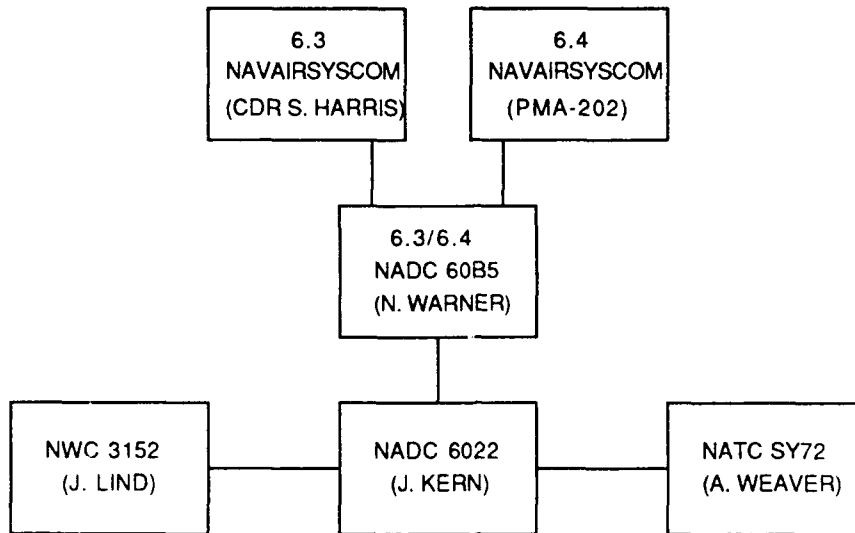

Figure 1. Human Factors Engineering Tool Evaluation Project Organization

TASKS AND MILESTONES

The major tasks associated with the initial FY-90 effort include the following.

1. Literature review. Conduct a review of current literature to ascertain how HFE tools have been developed, used, and evaluated and to learn of validation methods that may be applied to this effort.
2. Taxonomy development. Develop an organizational framework that provides for the initial assessment and selection of tools for further evaluation.
3. Validation process development. Whereas the tool taxonomy will serve for evaluating and selecting tools, a metric or experimental paradigm is needed to validate each tool or class of tools.

The overall project schedule by phase is included as Figure 2.

A related effort includes performing informal evaluations of Cockpit Automation Technology (CAT) and Army-NASA Aircrew/Aircraft Integration (A3I). These evaluations are being conducted by NADC and NATC personnel respectively.

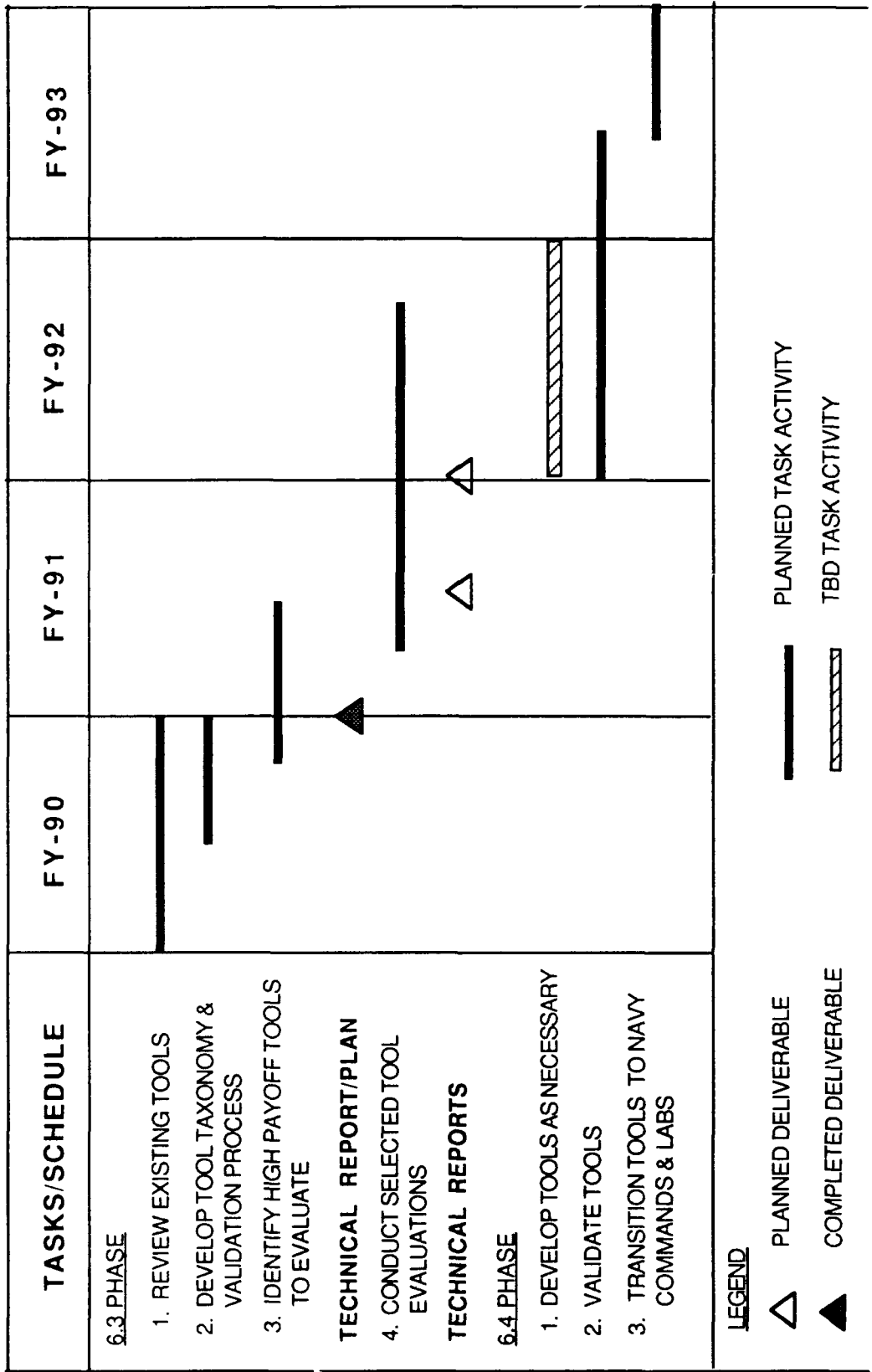

Figure 2. Human Factors Engineering Tool Evaluation - Tasks and Milestones

Evaluations of these two systems are being monitored to determine the approach and methodology being used. Both systems are in the Beta phase of testing. Lessons learned may be available that are related to the evaluation process, the metric used, and the specific evaluation technique for the tool. Technical Reports on these evaluations are expected during FY-90.

RESULTS OF THE LITERATURE REVIEW

PREVIOUS SURVEYS OF HFE TOOLS

Two major survey-type efforts have attempted to link Human Engineering technologies and tools to the Human Engineering requirements that are associated with the weapon system acquisition process. The first resulted in a report by Baker and others (1979), entitled, Human Factors Engineering for Navy Weapon System Acquisition. This report tied the Human Engineering methods, techniques, and tools that were available or emerging during the mid to late 1970s to the acquisition process. In addition, Human Engineering technology gaps were identified and recommendations made to fill in these gaps. Unfortunately, the technology gaps reported in 1979 have not yet been adequately bridged. Presently, with a more complex acquisition process and reduced funding for front-end analysis and design studies, a whole new list of shortfalls could be documented.

The most recent survey report was by Fleger and others (1987), entitled, Advanced Human Factors Engineering Tool Technologies. This effort was sponsored by the Army and also tied Human Engineering technologies to the milestones associated with the weapon system acquisition process. The survey focused on advanced, software-oriented tools rather than on traditional techniques. Advanced tools include prototype tools as well as tools currently in use.

Overall, it was found that the use of advanced tools by Human Engineering practitioners is not widespread. Many of the automated aids are considered novel alternatives and have been largely unexplored. The overwhelming consensus among respondents was that computerized tools were needed by the Human Engineering professional. Future tool development should focus on the following categories.

1. Expert systems
2. Human Factors data base compendiums
3. Workload prediction
4. Automated task analysis.

Human Engineering tools that were available for review during this industry survey were evaluated on the following points.

1. In use/in development

NADC-91038-60

2. Capability to augment/replace traditional tools
3. Effectivity/reliability
4. Transportability (hardware compatibility)
5. Versatility (useful in a variety of settings)
6. Appropriateness (when used).

A tool taxonomy was then created consisting of nine attributes.

1. Advantages
2. Disadvantages
3. Phase of system design to be used for maximum effectiveness
4. Activity area (design, analysis, test)
5. Role (how used)
6. Type (kind of tool; what the tool is)
7. Class (area of application: what it does)
8. Status (conceptual, prototype, or operational)
9. Cost.

The tools recommended for procurement by the Army all received the following ratings.

1. Currently operational and commercially available for immediate implementation
2. Good adaptability and high utility
3. Low or moderate cost.

A total of 12 tools met these criteria.

1. SIMWAM (Task Analysis/Workload)
2. ZITA (Workload/Performance/Tracking)
3. MicroSAINT (Workload/Task Modeling)
4. DART (Workload; Assembly/Manufacturing Operations)
5. WOSTAS (Task Allocation/Workload)
6. HF-ROBOTEX (Robotics/Expert System)

NADC-91038-60

7. GRASP (Robotics/Reach Analysis)
8. CAR (Reach Analysis)
9. WORG (Workstation Arrangement)
10. GEOMOD (Workstation Design)
11. CADAM/ADAM & EVE (Workstation/Reach Analysis)
12. CAPRA (Maintenance Analysis).

These were the tools recommended by Fleger and others (1987) for use by the Army.

Since the Navy is primarily interested in tools specifically for aviation related work or tools that can be applied to aviation type problems, the tools listed above were reviewed for this quality. Of the 12 tools listed above, the following tools are considered to be aviation related.

1. SIMWAM (Task Analysis/Workload)
2. ZITA (Workload/Performance/Tracking)
3. MicroSAINT (Workload/Task Modeling)
4. CAR (Reach Analysis)
5. GEOMOD (Workstation Design)
6. CADAM/ADAM & EVE (Workstation/Reach Analysis)
7. CAPRA (Maintenance Analysis).

In summary, 88 tools were surveyed and documented and 12 were recommended for use by Fleger and others (1987). However, for purposes of this report, only 7 tools can be considered as potential candidates for use on Human Engineering problems related to military aviation.

Based on the Fleger survey, advanced tools which run on a microcomputer for use by military research and development laboratories and test and evaluation activities would be most valuable to the Human Engineering practitioner.

In reviewing the Fleger report, cost was a major factor affecting the final recommendations. The criterion of low to moderate cost may have unnecessarily reduced the list of recommended tools. An overall cost rating was assigned to each tool based on (1) acquisition cost, (2) setup cost, (3) training cost, and (4) host computer cost. Except for acquisition cost, this cost rating may be somewhat arbitrary. A tool rated as high in cost was not recommended in spite of technical merit. COMBIMAN (Computerized Biomechanical Man-Model), GENSAW (Generic Systems Analysis Workstation) and the Siegal-Wolf Model are examples of tools falling into

this high cost category. All have been used extensively during actual weapon system development (COMBIMAN and GENSAW primarily within the Air Force). All have no initial acquisition cost. However, these computer based tools have a high cost rating due to significant costs associated with setup, training, and the resources needed to keep them operational.

A key finding of the Fleger report is that validation has been accomplished for only one of the recommended tools, even though all received high marks for availability, adaptability, and utility. The tool reported to have been validated is DART (Data Analysis and Retrieval Technique). DART is a task model, workload, and timeline analysis tool which has been used in the manufacturing/assembly environment of commercial and military aircraft. The report states that DART has been validated extensively through motion analysis.

The results of reviewing the 1979 and 1987 surveys linking Human Engineering technologies to Human Engineering tool requirements may be summarized as follows.

1. Numerous tools with potential HFE applicability have been proposed. Some of these have actually been developed and have been used by the military.
2. Criteria used by previous investigators to determine whether a tool will be recommended for government procurement may not be appropriate for this current study. Overemphasis on cost as an evaluation factor has eliminated several otherwise highly rated tools from consideration.
3. Currently only one of the tools recommended by other investigators has been adequately validated. There have been validation attempts on several tools in the areas of human performance and physical accommodation but these tools have not been recommended due to other factors (e.g., poor usability).
4. No standardized or even accepted technique exists for validation of the various tools that might be considered for use by the Navy.
5. Tools recommended in the 1979 and 1987 reports almost exclusively are useful for only three of the Human Engineering tasks carried out routinely: (1) task analysis/ workload analysis, (2) anthropometric evaluations, and (3) workstation design. Many tools exist in these categories, while other Human Engineering techniques definitely appear to be under-represented.

TOOL TAXONOMY CONSIDERATIONS

The literature review revealed certain issues that must be considered while constructing a taxonomy of HFE tools. These include the following.

1. The nature of the process of system design
2. Relationship of tools to the weapon system acquisition process

3. Integration level of tools intended to be exercised jointly in a stepped or layered approach
4. Quality of the user interface
5. Potential for theories and principles, such as those expressed in a model, to be considered as tools
6. Assessment of real costs
7. Measurement of the level to which HFE goals are met, using various tools.

System Design Process

Rouse and Cody (1989) have characterized the first steps of system design as information seeking, in their assessment of the criteria that design engineers use for choosing human performance models. They describe the system design procedure as a process of gathering and transforming information into a design. The information transformations occur on two levels.

1. Seeking, managing, and disseminating information
2. Formulating, associating, and evaluating information during the transformation into a system design.

Human performance models, as well as the output of other Human Engineering tools, are considered information sources. From initial mission analysis and concept formulation through full-scale development and deployment, information is sought for various design issues. These include establishing functional requirements, creating and analyzing solution alternatives, investigating solution details, and designing and developing solutions. Information needs related to Human Engineering are represented by things such as task allocation, crew performance, and workspace design.

Cody and Rouse (1989) document the three principal sources of information that a design team will access during the course of system design.

1. Human judgement (opinions of team members, domain experts, system users)
2. Archives (past designs, standard practices, scientific and technical literature)
3. Models (empirical studies using human subjects and analytical tools using simulations of the human component).

One important finding by Cody and Rouse is that the frequency of access of these information sources by system designers occurs in the order listed above (first judgement, then archives, then models). Frequency of access is determined by seven specific criteria a designer uses to evaluate

the value of an information source. Furthermore, these criteria seem to be applied as a series of gates or filters in the following sequence.

1. Applicability (can the source produce information that is directly relevant to the problem?)
2. Credibility (is the information from the source perceived to be valid?)
3. Availability (is the source commercially accessible, in a development stage or proprietary?)
4. Cost (is the cost of obtaining and using the source acceptable?)
5. Interpretability (are outputs from the source directly usable or easily transformed for the purpose at hand?)
6. Learnability (can one become proficient in producing information with the source in an acceptable period of time?)
7. Usability (once mastered, is the source easy to configure and use?).

Using these criteria, models are perceived by system designers to be weak when compared to the other alternatives of human judgement and archives (e.g., past designs). This is due to the fact that system designers can be seen as consumers who are trading off the expected benefits and costs of seeking the information needed to support design decisions. In this case, models are perceived to compare poorly with other sources in terms of a cost-benefit relationship.

Weapon System Acquisition Process

In keeping with the objectives of this current effort, a tool must relate to and support the accomplishment of a Human Engineering task associated with the weapon system acquisition process. But how do we demonstrate this connection? All Human Engineering tools could seemingly be linked in some manner to the major milestones associated with the acquisition cycle via the traditional Human Engineering tasks. However, the process of acquiring a new or modified weapon system, in practice, has many variations. Furthermore, the traditional Human Engineering tasks are often not successfully linked to these variations in the acquisition process.

Some general use tools are not directly linked to Human Engineering tasks associated with the acquisition of a weapon system. These include statistical packages, novel uses of spreadsheets, database management programs, and hypertext packages. Yet these tools should be included in the taxonomy for further review.

The number of tools available to support a particular Human Engineering task in the weapon system acquisition cycle may lead to a decision point. If there is a large number of tools available to support a specific task, it is possible to be selective. If there is a limited

number, what is available can be accepted, or a recommendation can be made to develop what is needed.

Integrated Sets of Tools

Recent developments have shown that related HFE tools can be at least physically integrated for use at a common workstation. As evaluators and users of tools a question must be posed: Does the integration of various tools, versus stand-alone tools, add to the overall value or effectiveness of the tools?

Various levels of integration are possible.

1. Single-user workstations with individual tools packaged together and selected via a common user interface shell (e.g., main menu).
2. Single-user workstations and common user interface with multiple tools that can be accessed and used interactively (e.g., Wherry's Human Engineering Tools (Wherry 1990), prototype system implemented with hypertext-type software).
3. Multiple-user workstations used to exercise multiple tools in a step-by-step approach to design; the output files created via one tool may be used independently or as inputs to another related tool (e.g., Cockpit Automation Technology (CAT) Program, Air Force Systems Command).

User Interface Quality

A critical feature or characteristic of a tool is the quality of the user interface. Is the tool useable with moderate training? First generation automated HFE tools have been characterized by poor user interfaces. This factor has limited their utility in meeting the real needs of HFE practitioners.

Models as Tools

The potential for using a model as a tool requires an in-depth assessment. Considering the definition for a HFE tool used in this report, where does a model fit in? When does a model reach a state of utility such that it can be considered as a tool?

Models have been used by researchers to demonstrate theories of human performance and have been used by Human Factors specialists to answer questions of feasibility in system design. The most promising human performance models are computational models that can be or have been implemented in a computer. Pew and others (1977) state that models can take various forms. They can be a verbal/analytic statement of principles or provide a closed-form mathematical solution.

If not computerized, a model must have certain features in order to qualify as a tool. There must be input, a transformation, and output. For purposes of this study, the output must be useful for the weapon system acquisition process.

Various authors (Pew and others, 1977) have evaluated the quality of models in terms of reliability and validity.

Reliability means that repeated applications yield the same or substantially similar results. It is difficult to judge the reliability of recent models because they have not had the benefit of repeated application.

Validity is the correlation of the results of a test with an outside criterion or independent measure. This correlation provides an index of model validity. A validity test seeks to answer the question, does the modeling tool measure what it is intended to measure?

The validation of software tools that contain embedded models (e.g., human performance models) may raise several questions.

1. Is the model logically consistent?
2. Is sufficient empirical evidence available to support the model?
3. Can we perform the Human Engineering task without the model?
4. Do we validate the model itself or accept the model and validate whether the software tool uses the model correctly?
5. Does a tool with an embedded human performance model (e.g., the Wickens Multiple Resource Model) add to its value? What added value does the model provide? An assessment of added value may take the form of a subjective evaluation, followed by a simulation study and comparison of predicted and observed results.

The problem of using models of the human component of a complex weapon system is being addressed on a large scale by the Army-NASA Aircrew/Aircraft Integration (A3I) Program. This program involves the development of a prototype of a Human Factors computer-aided engineering (CAE) facility for the design of helicopter cockpits. The A3I CAE facility is an evolving set of tools, based on models of human performance, supported by a flexible integration framework. The objectives are as follows.

1. Review current models of human performance
2. Identify those models that would be most useful for the CAE facility
3. Identify limitations of the models
4. Provide guidance for the use of these models in the CAE facility
5. Recommend research on models and modeling that might overcome existing limitations.

Details of an initial study of using human performance models for a CAE facility were reported by Elkind and others (1989). The scope of this study was limited to the visual and associated cognitive functions required of pilots in the operation of advanced helicopters, which often fly under low-visibility and low-altitude conditions.

Assessment of Costs

An assessment of the cost of an HFE tool involves costs associated with acquisition, setup, training, and resources (hardware, vendor support, etc.). For example, some tools have been documented as having a high overall cost by Fleger and others (1987) even though there is no acquisition cost. The costs associated with setup, training, and resources can add appreciably to the total cost.

For commercial products, vendor support can represent a substantial and recurring cost and must be assessed. Evaluation factors for vendor support include

1. Viability of the company supporting the tool
2. Availability and quality of documentation
3. Availability of training.

Measuring Whether HFE Goals Are Met

An evaluative process must occur in order to determine whether Human Engineering objectives are met during the course of system design. The lack of metrics that can be used for the evaluation of the design adequacy of a system is a major deficiency of current Human Engineering technology.

Measures of effectiveness and preset criteria of system adequacy are needed. A metric is required to solve the problem of what to measure and how this measurement will be made. Wherry (1990) has stated that when the metric involves a pass/fail decision, three considerations must be addressed.

1. Operationally defining a criterion variable that can be measured
2. Defining the process by which things will be measured on that variable
3. Defining where the line is to be drawn between "acceptable" and "unacceptable".

TOOL EVALUATION AND VALIDATION METHODS

Based on the literature review, methods that can be used for evaluation and validation may be categorized as follows.

1. Subjective analysis. Several techniques can be used and various kinds of questions answered.
 - a. Informal demonstration that a tool produces reasonable results (Pew and others, 1977)
 - b. Does the tool perform as advertised?
 - c. Are the results that are obtained plausible?
 - d. Is the tool widely used or seldom used?
2. Experimental studies. Compare actual human performance with the predictions of the tool. This technique can cover the range from part-task lab studies to real-time manned simulations.
3. Nonexperimental studies. Two procedures are commonly used.
 - a. Compare tool predictions with estimates of various parameters (i.e., operator efficiency) by operational personnel (Pew and others, 1977).
 - b. Compare tool predictions with results (i.e, empirical evidence) or information obtained from field experience (Pew and others, 1977).
4. Systematic violation of the assumptions on which the model or tool is based, using simulation runs. Under what conditions does the model/tool maintain validity? One approach to this method is to use one tool to validate another (Chubb and others, 1987).

For purposes of this study, evaluation and validation are considered to be two separate steps in determining the usefulness of various HFE tools. Individual tools are evaluated using subjective analysis. The goal of these evaluations is to decide if specific tools should be considered as candidates for formal validation. During the evaluation process, information about each tool is reviewed to determine whether the following criteria are met.

1. The tool is useful for some task or procedure carried out by DOD HFE practitioners during the weapon system acquisition cycle, and be consistent with existing DOD test and evaluation procedures and criteria.
2. The tool (and any related required hardware or software) is currently available, at "reasonable" cost, or will be available within a "reasonable" period of time.
3. The tool produces results that are realistic, plausible, in useful form, and similar to empirical results when these exist.
4. The tool appears to be easy enough to learn and to use that DOD HFE practitioners actually will use it.
5. The tool is one of the best for its purpose, when compared with other tools and techniques that may be used to aid HFE practitioners with a given task.

Following evaluations, promising HFE tools will be validated objectively. Methods such as experimental studies, nonexperimental studies, and assumption violation procedures (as discussed above) can be used for this more formal process. Some recent tool validation studies from the literature are provided as examples of how others have approached evaluation and validation.

Anthropometric Tool Evaluation

The goal of a study conducted by McConville and others (1989) was to assess the accuracy and reliability of the Automatic Anthropometric Data Measuring System (AADMS) in obtaining body size measurements of Navy personnel. The results from AADMS were compared to results obtained from four other measuring systems.

1. Two versions of the Integrated Anthropometric Device (IAD)
2. Techniques used for the 1964 anthropometric survey of Naval aviators
3. Techniques used in the 1988 Army anthropometric survey.

The evaluators reported that the AADMS provides a level of measurement reliability as good as or better than any of the other techniques and devices tested. AADMS permits the measurement of more relevant cockpit accommodation dimensions than does IAD. With its automatic measurement recording capability, it also can instantaneously edit and evaluate data. AADMS provides a printout of a subject's personal anthropometric data and any aircraft anthropometric restrictions for that subject. However, the present configuration of AADMS needs improvement, since it now requires skilled technicians for its maintenance (hardware and software).

Method of Tool Evaluation: Quantification of the differences between various measuring techniques by actual measurement of a series of dimensions on a sample of test subjects.

Crew Station Design Tool Evaluation

Binder and others (1988) performed an assessment of the System for Aiding Man Machine Interaction Evaluation (SAMMIE). SAMMIE is a computer model used as a crew station design tool. This study used SAMMIE to perform a crew station accommodation test. The test involved human subjects and a crew station mockup, to test both MIL-STD-1333 Zone 1 and Zone 2 reach. The results were compared with CAR-IV crew station accommodation analysis on the same crew station. Evaluators reported that agreement rates between the test subjects and the respective computer model showed that SAMMIE compared favorably with CAR-IV.

Method of Tool Evaluation: Computer model-generated reach data were compared to the results obtained experimentally using human subjects and a crew station mockup.

Workload Analysis Tool Evaluation

Chubb and others (1987) developed a model for workload analysis called Saturation of Tactical Aviator Load Limits (STALL). Model validation involved developing SAINT (Systems Analysis of Integrated Networks of Tasks) equivalents of the STALL model and verifying these against the STALL results.

Method of Tool Evaluation: SAINT models were used for systematic violation the assumptions on which STALL is based. If the assumptions are valid in a particular application, this demonstration provides an indicator of model robustness.

DEVELOPMENT OF AN HFE TOOLS TAXONOMY

HFE PROCEDURES TAXONOMY

A major goal of this project is to identify a set of HFE-related tools for use by Navy laboratories during the system acquisition process. Each tool must meet a recognized need if it is to be considered--a need related to the routine tasks carried out by Navy HFE practitioners as they define and evaluate the work of contractors.

To be considered for purchase, each tool also must be cost effective and, if possible, the best of its type. Thus tools used for similar purposes must be compared to one another. To compare various HFE tools, it is necessary first to categorize them into groups of tools that have similar purposes. Two categorization schemes have been used for this process.

1. The weapon system acquisition phases during which HFE tools might be used.
2. The established HFE tasks and procedures for which tools might be used.

Using these two categorization schemes, a Taxonomy of Human Factors Engineering Procedures has been developed to facilitate sorting the tools for comparison and evaluation (Appendix A). That is, a complete, detailed list was prepared documenting essentially all of the HFE tasks (approximately 115 procedures) commonly carried out during all of the five phases of system acquisition.

Contractor tasks are included in that list as well as tasks performed by Navy personnel to ensure that all procedures are considered. Several attributes of each procedure are included (as discussed below) and a rough, preliminary tally is provided for the number of HFE tools possibly available to aid with each task. Microsoft Windows 3.0 and the Microsoft Excel spreadsheet program were used to enter and manage the information for this HFE Procedures taxonomy.

A listing of common HFE tasks serves several functions. As noted, it can be used to place tools designed for the same task into one category, for comparison. It also helps put the HFE procedures themselves into perspective so each can be compared with the others. During the various acquisition phases, which tasks are the most important, and so justify the expense of tool acquisition? Which procedures are the most difficult, and thus truly require the assistance of tools?

Weapon System Acquisition Phases as Tools Categories

Since the HFE tools will be used to aid Navy HFE practitioners during the weapon system acquisition process, the phases of that process provide one logical set of categories: tools used during the same acquisition phase can be grouped together. The weapon system acquisition process usually is divided into five phases. Each phase includes various tasks that must be completed prior to a major program milestone.

1. Pre-Milestone 0, the mission analysis phase.
2. Pre-Milestone 1, the concept development or program initiation phase.
3. Pre-Milestone 2, the system demonstration and validation phase.
4. Pre-Milestone 3, full-scale engineering development phase.
5. Post-Milestone 3, the production and deployment phase.

HFE Procedures and Tasks as Tools Categories

The kinds of procedures and techniques that commonly are used by Human Factors personnel provide another way to separate HFE tools into reasonable categories: tools used for the same general purpose can be included in one category. Appendix A includes a comprehensive listing or taxonomy of some 115 HFE procedures which can be used to classify tools according to their functions.

For a given program, these HFE procedures often begin with a mission analysis and with planning how the HFE program will be carried out. They continue with task, workload, display and control, manpower, job, and other kinds of analyses. The procedures culminate in tests and evaluations of prototype or developmental systems, as needed to determine that HFE goals have been met.

Figures 3, 4, 5, 6, and 7 show some of the Human Factors tasks normally performed, as these relate to each of the system acquisition phases and milestones. Figure 8 illustrates how the HFE procedures and the acquisition phases relate to one another and to the placement of tools into groups, for this study.

HFE TOOLS TAXONOMY

As developed for this study, the HFE Tools Taxonomy database is built on the five weapon system acquisition cycle phases and 115 HFE tasks

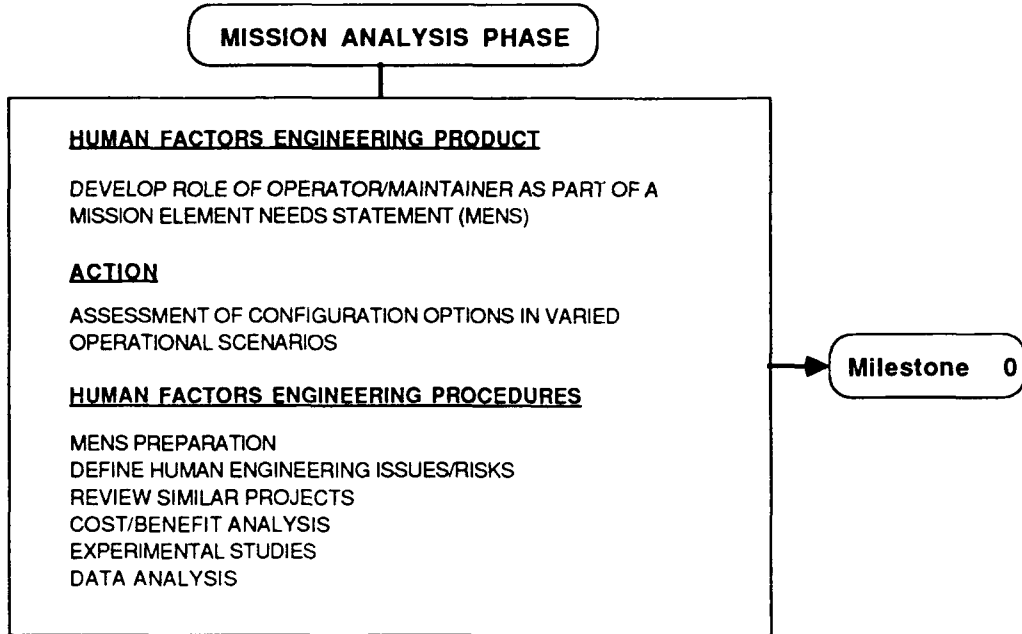

Figure 3. Human Factors Engineering Product, Action, and Procedures Related to the Mission Analysis Phase of the Weapon System Acquisition Cycle, Prior to Milestone 0.

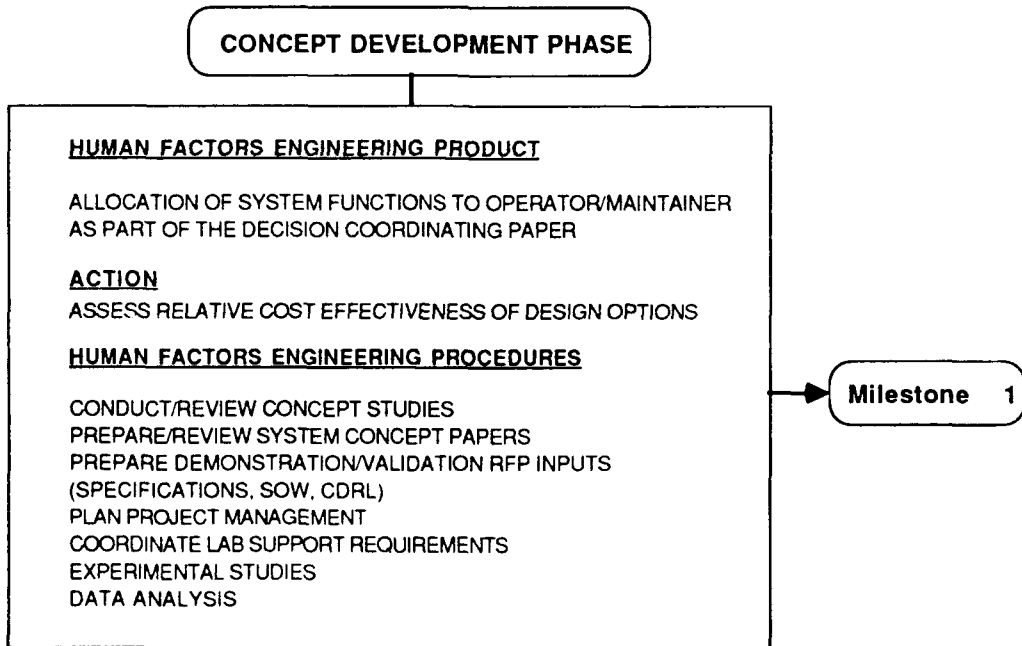

Figure 4. Human Factors Engineering Product, Action, and Procedures Related to the Concept Development Phase of the Weapon System Acquisition Cycle, Prior to Milestone 1.

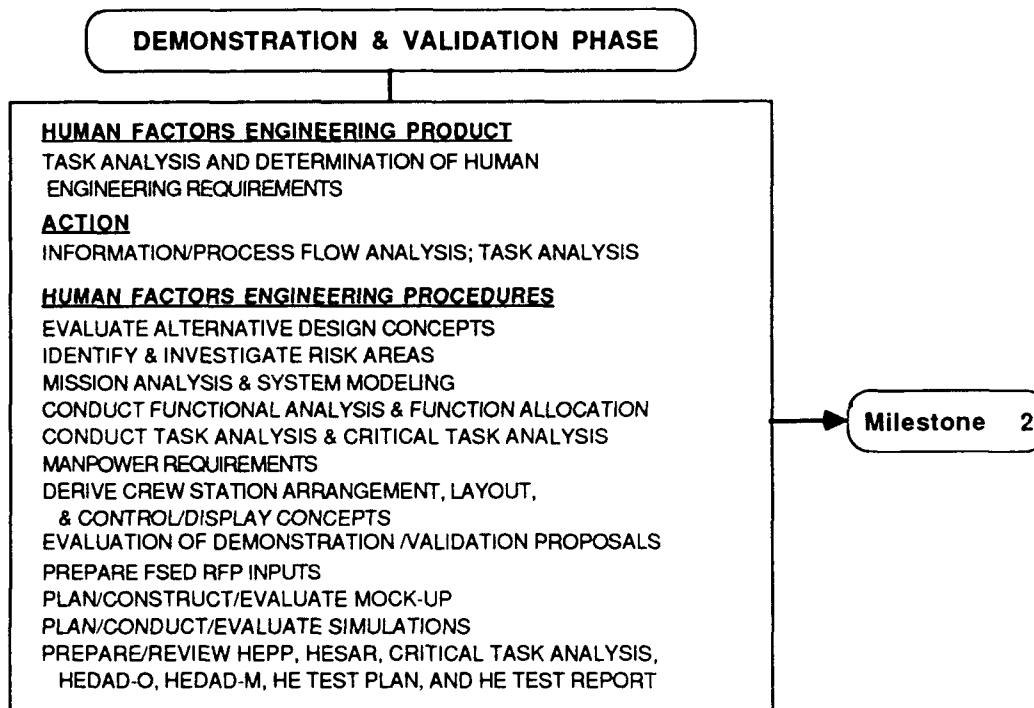

Figure 5. Human Factors Engineering Product, Action, and Procedures Related to the Demonstration and Validation Phase of the Weapon System Acquisition Cycle. Prior to Milestone 2.

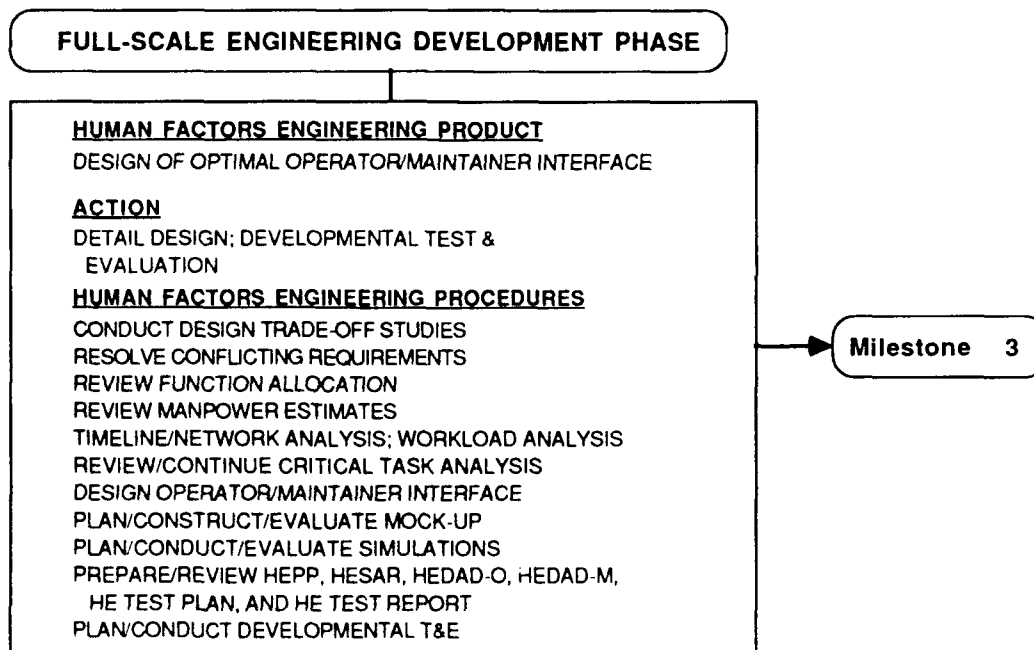

Figure 6. Human Factors Engineering Product, Action, and Procedures Related to the Full-Scale Engineering Development Phase of the Weapon System Acquisition Cycle. Prior to Milestone 3.



Figure 7. Human Factors Engineering Product, Action, and Procedures Related to the Production and Deployment Phase of the Weapon System Acquisition Cycle, Following Milestone 3.

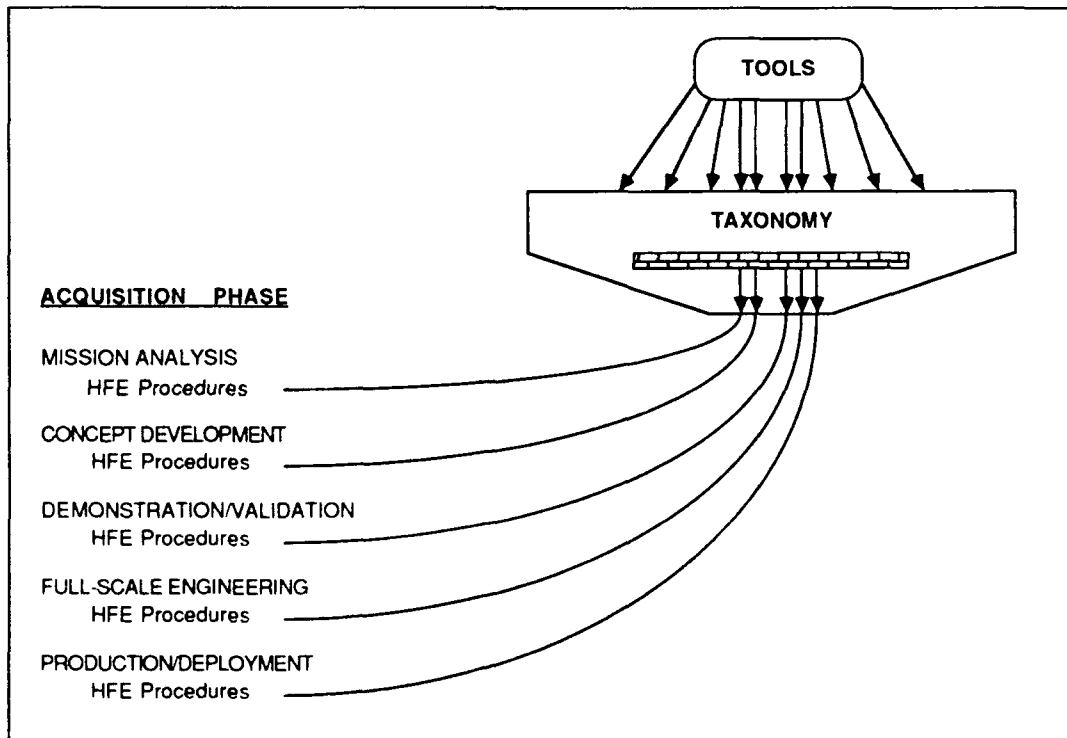

Figure 8. Relationship of Human Factors Engineering Procedures and Weapon System Acquisition Phases to the Human Factors Engineering Tools Taxonomy

documented in the Taxonomy of Human Factors Engineering Procedures spreadsheet (Appendix A). Each tool is categorized according to the procedure or procedures for which it is designed, and tools are grouped according to one or more of the phases for which each is appropriate (some procedures and tools apply to more than one phase). The HFE Tools Taxonomy has been partially implemented using Microsoft Windows 3.0 and Precision Software's Superbase 2 database management software.

Figure 9 illustrates graphically the hierarchical construction and contents of the HFE Tool Taxonomy. Various important attributes of the HFE procedures and of the tools themselves are included. These attributes are discussed below.

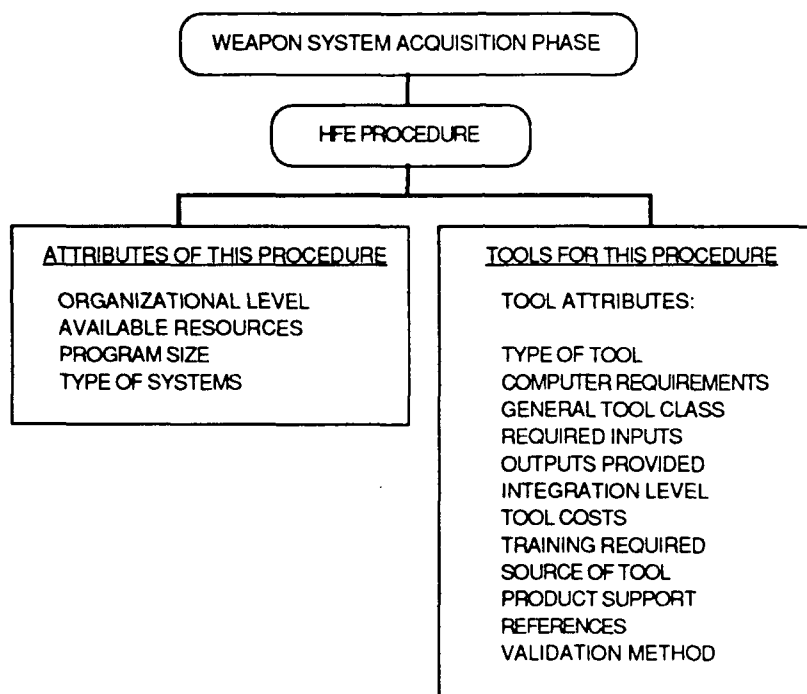

Figure 9. Overall Design of the HFE Tool Taxonomy Developed for this Study, Including Attributes of HFE Procedures and HFE Tools

TAXONOMY INFORMATION RELATED TO THE HFE PROCEDURES AND TASKS

The system acquisition phase in which each HFE procedure is carried out is important, but is only one of the items that must be considered in taxonomy development. It is useful to specify several other attributes for each HFE procedure in order to determine who in the weapon system acquisition cycle is most likely to use the procedure, under what conditions it will be used, and where it probably will be used. It is

useful also to identify existing, common resources (primarily documents) already provided by the government to aid HFE practitioners with these procedures.

All of these factors contribute to determining the priority level of each procedure, and thus also affect the priority which should be assigned to tools related to the procedure. The following four attributes of the procedures are included in the HFE Tool Taxonomy.

1. The Navy organizational level at which each of the various procedures normally is carried out.
2. The kinds of resources (military documents) that already are commonly available to assist HFE personnel with each procedure.
3. The size a program must be before it is cost effective to include a given procedure.
4. The kinds of systems (surface, air, etc.) to which each procedure applies.

Level at Which Tasks Are Carried Out

The HFE tasks and procedures carried out during system acquisition can be divided into four levels, based on which organization or organizational level usually has primary responsibility for their completion (Merriman, 1986).

1. Major milestones and events associated with weapon system acquisition that drive all other tasks. These tasks generally are the responsibility of the system Program Manager.
2. Systems Command-level tasks (NAVAIR, NAVSEA, etc.) which drive contractor and laboratory efforts. For Navy and Marine Corps crew stations, these tasks generally are the responsibility of AIR-5313.
3. Tasks usually (but not always) carried out by the contractor which is responsible for system development.
4. Tasks usually (but not always) carried out by the Navy's support Laboratories.

Existing Task Resources

HFE practitioners routinely make use of numerous military standards and specifications documents while carrying out their tasks. The following documents are primary resources for system acquisition, providing information about optimum systems designs to meet the needs of human operators and maintainers, and about how various HFE procedures (including preparation of reports) should be carried out.

1. MIL-STD-1472, Human Engineering Design Criteria for Military Systems, Equipment and Facilities

NADC-91038-60

2. MIL-H-46855, Human Engineering Requirements for Military Systems, Equipment and Facilities
 3. Data Item Descriptions (DIDs):
 - DI-HFAC-80740, Human Engineering Program Plan
 - DI-HFAC-80741, Human Engineering Progress Report
 - DI-HFAC-80742, Human Engineering Dynamic Simulation Plan
 - DI-HFAC-80743, Human Engineering Test Plan
 - DI-HFAC-80744, Human Engineering Test Report
 - DI-HFAC-80745, Human Engineering System Analysis Report
 - DI-HFAC-80746, Human Engineering Design Approach Document-Operator
 - DI-HFAC-80747, Human Engineering Design Approach Document-Maintainer
- DI-H-7055, Critical Task Analysis Report.

Program Size Effects on HFE Procedure Usage

Not all HFE procedures are necessary for each and every system obtained by the Navy. The amount of time and money spent on Human Engineering tasks is a function of the size of the project program. For convenience, programs can be divided into three size categories.

1. Large: a major program, such as development of a new aircraft or man-in-the-loop missile. Only very large projects will warrant the inclusion of most of the tasks included in the taxonomy.
2. Medium: a medium-size program, such as a major aircraft modification.
3. Small: minor projects such as an aircraft modification or the addition of a new mode to a missile.

Kinds of Systems the Procedures Are Used With

Some HFE procedures are specific to certain kinds of military systems. The need to analyze the operator's visual field, for example, normally is unique to development of aircraft systems. Dynamic simulation of the operator's mission also usually is limited to aircraft systems, since this procedure is very expensive. Thus, HFE procedures can be identified as useful for all kinds of systems, or as being primarily useful for shipboard, subsurface, aircraft, ground vehicle, or weapon systems.

TAXONOMY INFORMATION RELATED TO THE INDIVIDUAL HFE TOOLS

For a tool to be considered for inclusion in the HFE tools taxonomy, it must be related to the system acquisition cycle and must be useful for at least one of the HFE procedures enumerated in the taxonomy. Thus, in order to specify how its output will be used, each tool is assigned to the HFE procedure for which it is most useful (resulting in numerous tool listings for some procedures, and none for other procedures).

Information is needed in the taxonomy to evaluate and to compare related systems, in order to determine what tools are to be used for various procedures, that is, to select the best tool for a given function. For each tool, this information includes the type of computer assets required (if any), inputs required, outputs provided, costs, etc. A total of 12 useful tool attributes were identified and are included in the taxonomy. These tool characteristics are discussed below.

Basic Type of Tool

For purposes of this study, tools can be divided into two basic types.

1. Computer-based programs, software, databases, etc.
2. "By-hand" or manual techniques that do not require a computer for use.

Computer Assets Required

For those HFE tools that do require a computer, the type of computer system that is required is very important. For practical purposes, the HFE "tool kits" that will be developed must be operable on reasonably inexpensive, widely used systems, such as the Macintosh or an IBM-PC compatible.

Some tools may require a specific computer operating system such as UNIX (or even a specific version) for computer compatibility. Some tools are built on existing commercial computer programs (such as Turbo Pascal) or packages (such as Lotus 1-2-3). Users must purchase these products in order to use the tool. When limitations and restrictions exist, they must be clearly noted.

General Class of Tool

HFE tools can be placed into classes depending on the general types of products they represent. Approximately 10 classes were identified for this study, and are described in detail in Appendix B. Classes include the following.

1. Standards, specifications, or sets of HFE principles
2. Handbooks or textbooks
3. Databases of HFE-related data

4. Inputs to the HFE sections of Requests for Proposals (RFPs)
5. Crewstation layout tools
6. Man modeling or anthropometrics tools
7. Analytical techniques (task analysis, etc.)
8. Assessment tools (workload, etc.)
9. Hardware design tools
10. Interface (usually software) design tools
11. Simulation software
12. Prototyping tools
13. Engineering tools
14. Manufacturing tools
15. Tools for use during the formal test evaluation process

Inputs Required by the Tool

Every HFE tool requires data or information inputs in order to produce results. Inputs usually provide data about the system that is being designed or evaluated and about the intended human operators and maintainers of the system. It is critical that all required inputs be readily available and easy to enter into the system (whether using a computer or "by-hand" technique) or HFE practitioners will not use the tool.

Outputs Provided by the Tool

All HFE tools also provide outputs, the end result products after the HFE task or procedure is completed. Obviously the outputs must be those desired and needed by HFE practitioners. Outputs also must be in a readily useable form, not requiring transformations or other manipulations.

Integration Level of Tools

Some existing HFE tools have been designed for a single purpose or to meet a single need. Other tools have been designed as part of a package intended to meet several needs of HFE personnel. Outputs from the use of one such "integrated" tool often can be directly used as inputs to another procedure in the same package. All tools in a given package may be necessary for the system to work properly, but not all of the tools may be of equal quality. Thus, for the taxonomy each HFE tool is identified as belonging to one of two categories.

1. Stand-alone tools that assist with one procedure.

2. Integrated packages of tools which help with several (usually related) procedures.

Tool Costs

Some HFE tools (books and "by-hand" techniques) are relatively inexpensive and thus could be included in each "tool kit" at minimal initial cost. If computer-based software runs on a Macintosh or an IBM-PC system, it probably can be assumed that computer hardware already is available at the Laboratories and will not have to be purchased--making these systems also relatively inexpensive. On the other hand, simulation software, and prototyping and engineering tools generally are very expensive if special hardware is required.

Initial purchase is only one part of total cost; the costs of system setup and continued support and maintenance can be significant.

In general, tool costs can be categorized as follows.

1. Inexpensive and could be made available to all the Navy Laboratories: total cost under \$2,000 for one package.
2. Moderately expensive but could be made available to one or more Laboratories if the product is very good: total cost between \$2,000 and \$10,000 for one package.
3. Expensive but could be considered for one or two Laboratories if the product is very good and aids with several important, difficult tasks: total cost between \$10,000 and \$25,000 for one system.
4. Very expensive and probably practical only for one Navy Laboratory, highly involved in that HFE procedure: over \$25,000 for one system.

Training Required for Tool Use

The amount of training needed to use an HFE tool effectively is a major component of the overall cost of using it--and a major determiner of whether HFE personnel actually will use a tool. Training requirements can be categorized as follows.

1. Minimal: less than 8 hours of training required.
2. Moderate: between 8 and 40 hours of training required.
3. Considerable: more than 40 hours of training required.

Acquisition Source for Tool

Existing HFE tools may be obtained from several kinds of sources.

1. Government Laboratories and other government facilities which have developed the tool (or paid for its development) so can provide it at cost to Navy Laboratories.
2. Universities and individuals who have developed HFE tool systems and have permitted these to enter the public domain, free of cost to users (and also unsupported by developers).
3. Commercial system developers who will sell (and usually support) their HFE tools.

Level of Product Support

The level of product support available from the HFE tool's vendor, or other supplier, including documentation, training assistance, system debugging, and program updates, can be categorized as follows.

1. High: adequate support.
2. Moderate: some support; problems may arise over time.
3. Low: minimal vendor support can be expected.

References Providing Tool Information

Personal contacts, or reports or other documents describing each promising HFE tool, are necessary in order to obtain additional information needed for subjective evaluations.

Validation Procedures Appropriate for the Tool

Once selected for further consideration via the evaluation process, HFE tools that are used for different purposes will require different validation techniques. Validation techniques can be placed in several categories, as discussed earlier.

1. Subjective analysis
2. Experimental comparisons
3. Non-experimental comparisons
4. Systematic violation of the assumptions on which this tool is based.

EVALUATION AND VALIDATION OF TOOLS

The evaluation and validation of the following tool has been planned as part of the 6.4 phase of the Advanced Technology Crew Station (ATCS) Program.

Anthropometric Computer-Aided Design System (ACADS)

One of the first tools to be evaluated under this program will be the Anthropometric Computer Aided Design System (ACADS). Information about this system has been reported by Dunn (1989). The ACADS procedures are common with the evaluation procedures used in mock-ups and prototype cockpits. This creates a consistent evaluation method for use in research, development, and test and evaluation.

The object of ACADS is to create three-dimensional (3-D) computer records of actual human subjects from video recordings. By video recording the human subject in a particular ejection seat or other crew station seat, the physical position of the subject and the spatial location of specific parts of the subject's body may be accurately determined. This video record is collected under varying conditions of movement, attire, gravity forces, and restraint. The ACADS-generated 3-D computer pictorial template can be manipulated in any direction and about any axis.

The pictorial templates can interface with computer-aided design (CAD) models of aircraft crew stations. This enables a designer or evaluator to place the computerized 3-D template of an actual human subject into the CAD crew station, adjust the subject's position, and accurately assess anthropometric fit and function, including reach and visual field of view.

According to Dunn, this new capability will aid weapon system developers in evaluating the anthropometric aspects of their crew stations while in the design and development phases. It will also provide the Government with a valid evaluation tool to assess compliance with new disproportionate anthropometric matrix requirements which are now specified by the Navy and Air Force for aircraft weapon systems. Accommodation is required for a range of crew personnel, based on a "disproportionate matrix" of body dimensions. Assessment of resulting cockpit geometry while in the design and development stages is a continuing problem.

The evaluation of fit, function, and escape of the aircrew has previously relied on the use of anthropometric models. Although many of these models exist, no validated anthropometric system is available that can evaluate with sufficient accuracy crew station geometry for crew accommodation in a new weapon system. The failure of models in cockpit dimensional evaluation results in part from the inability to integrate the human within the crew station, due to the differential effects of clothing, seats, restraint systems, and personnel gear, as well as anthropometric variations. The use of calculated rather than empirical measurements in weapon system design is a source of design errors which have proven very costly in terms of restricted manpower, restricted performance and engineering changes. This tool will be validated by comparison with data derived by empirical methods.

TOOL TYPES AND TOOLS CONSIDERED FOR EVALUATION

Based on the work completed during FY-90, certain types of tools have been identified for further evaluation. These tool types primarily support the front-end analysis and planning that has been lacking during weapon system design evolutions. If evaluations indicate that the tools meet project requirements, validations may follow.

HFE Acquisition Support

DOD HFE practitioners immediate needs within this tool category include assistance with program planning and the preparation of acquisition documents. Tasks include requirements tailoring (MIL-H-46855), modifying data item descriptions (DIDs), preparing the statement of work (SOW), and the development and preparation of design criteria using documents such as MIL-STD-1472D and related specifications and standards. Candidate tools are listed below.

Human Factors Engineering Planning Aid (Merriman, 1987) is a tool that applied off-the-shelf program management software to HFE planning in the context of complex weapon system developments. Interdependencies are created between models of the military system acquisition process and a HFE program plan so that changes made in the acquisition schedule causes the HFE plan to be automatically tailored. This planning aid also supports the definition of alternative HFE plans in anticipation of possible funding constraints, schedule changes, or other contingencies. This software is currently available at the NWC and the NADC. No additional hardware must be procured prior to an evaluation.

Smart Contract Preparation Expediter (SCOPE) is an expert system with embedded knowledge of HFE considerations and military equipment design. It is being developed by the U.S. Army's Human Engineering Laboratory (HEL), Aberdeen Proving Grounds, MD. SCOPE is intended for accurate generation of system acquisition documentation, including a tailored MIL-H-46855, statement of work, and data requirements. The current prototype version of SCOPE has been tailored specifically for the U.S. Army's Missile Command, HEL Detachment at Redstone Arsenal, Huntsville, AL. However a Navy evaluation would focus on features of this tool that could be adapted for Navy use. This software is available in a prototype version with no acquisition cost. Additional hardware must be procured prior to an evaluation.

MIL-STD-1472D, Human Engineering Criteria for Military Systems, Equipment and Facilities (Hypertext format) is an efficient way of manipulating HFE design criteria for various purposes. The current version of this military standard has been prepared in a hypertext stack format which enables quick location and extraction of specific items of information. An important use is for the preparation of acquisition documents. Extraction of design criteria for application to higher level specifications (e.g., a general specification) as tier 0 requirements is becoming a standard approach to acquisition streamlining. This product is now available from the Crew System Ergonomics Information Analysis Center (CSERIAC) for a cost recovery fee of \$75.00. Additional hardware must be procured prior to an evaluation.

System Analysis

The comparison of a baseline system with several versions of an upgraded system is an activity that frequently occurs prior to major system acquisition decisions. As a participant in this type of activity, DOD HFE practitioners can perform a comparability analysis. The impact on the human component of a system is assessed in this type of analysis. One tool has been identified for evaluation.

Crew Requirements Definition System (CRDS) is a methodology designed to evaluate the effects on the performance of designated missions of varying the crew size, task start times, task sequencing, and task allocations to crewmembers or equipment (Christ and others, 1989). The CRDS has been developed by the Army Research Institute (ARI) and will be available during FY-91. A tool of this type could be used to support an internal Navy analysis of system concepts and options or to evaluate the results of an analysis by a contractor. This software is available from ARI with no acquisition cost. No additional hardware must be procured prior to an evaluation.

Crew Accommodation Analysis/Reach Assessment

The need for a method of predicting crew accommodation and assessing reach acceptability that can be used early in a design process is well accepted. Currently no tool meets these needs adequately. One candidate for evaluation has been identified.

Crewstation Assessment of Reach (CAR) is a design tool for evaluating population accommodation in a workspace and the reachability of the hardware components that make up a workspace (Harris, R. and Iavecchia, H., 1984). Numerous evaluations of CAR have been completed by interested user groups. Due to prior attempts at validation, the limitations of the model are known and well documented. If improvements for the CAR model are desired, modifications to correct the known deficiencies can be undertaken in a cost-effective manner. Also, guidance on appropriate applications (i.e., when to use) can be added as supplementary information to CAR user documentation.

A proposed "standard" application of CAR is for the evaluation of conceptual or preliminary workstation designs prior to mock-up construction. Several alternative designs can be evaluated quickly and the output can be used as an input to preliminary drawings and mock-up design.

Currently, CAR has many government and commercial users. As a modeling tool, it remains inexpensive, easy to use, transportable (i.e., IBM PC compatible) and can provide a quick turn-around of recommendations related to an important aspect of physical workstation design. This software is currently available and in use. No additional hardware must be procured prior to an evaluation.

Rapid Prototyping of Hardware and Software

The primary issue with this class of tools centers around instituting "standard" tools that can be used by both Navy activities and industry.

With common tools, the results of rapid prototyping can be more efficiently evaluated and transitioned to detail design. Standardized tools are needed for addressing hardware design issues (e.g., crew station layout and arrangement) as well as software design issues (e.g., display formats and logical flow of activities). Candidate tools are listed below.

Apple HyperCard is a hypertext (i.e., nonlinear text) software product that is useful for linking or cross referencing between related text, graphical, or combined text/graphical units. Software products falling into the hypertext family exhibit a wide range of capability in handling graphical information. The ability to link non-textual units (e.g., diagrams) has been the prime driver behind the use of HyperCard (Apple Computer, Inc., 1988) as a rapid prototyping tool. Novel applications of this product are prevalent within the HFE community. This is a standard software product that is currently available and in use at the NADC and the NATC. Additional hardware must be procured prior to an evaluation.

ProtoTymer (Miller, D. and Stone, A., 1989) is a software instrumentation package that can record human interaction (e.g., button hits) with a HyperCard (Apple Computer, Inc., 1988) application. All of the events of a user interface session can be recorded for further analysis. The information can be used to assess learning time, number of errors, and other performance indices. This is a standard software product that is currently available. Additional hardware must be procured prior to an evaluation.

VAPS (Virtual Prototypes, Inc., 1988) is a software tool that addresses three problems that are common to all control and display systems: display formats, operator interface logic and human interface with other systems. The VAPS can support the development of solutions to these design problems simultaneously through fully dynamic system evaluations. This software runs on Silicon Graphics workstations. This system is currently available and in use at both the NADC and the NATC. No additional hardware must be procured prior to an evaluation.

Hardware Specification and Design

LIGHT/CRT MODEL is an engineering and human factors analysis tool that is currently under development at the NADC (Penn, 1990). This model will be used to assess the impact of ambient light conditions on CRT luminance, shades of gray, and color contrast prior to the availability of actual hardware. Based on inputs that include actual or desired hardware characteristics and illuminance conditions, the imagery generated by the model will simulate the interaction between the CRT performance and the environment. A preliminary version of the software will be available during FY-91. Additional hardware must be procured prior to an evaluation.

VALIDATION PROCESS

Prior to any validation study, it must be determined that the tool and its output are realistic for the HFE procedure for which it is intended. The type of level of validity to be determined should be related

to the priority of the tool within the scope of the HFE tasks discussed in this report.

Thus the first step in the validation process will involve reaching agreement on what tools are to be selected for validation. This group of tools for validation can be determined by evaluating various candidates. This evaluation phase will be helpful to the decision process.

Once the tools to be validated are known, the level of validation to be pursued can be set and an appropriate method for validation can be devised. The types of validity to be considered for various tools include the following.

Content validity is how well the tool covers the domain that it was designed to cover. The tool is reviewed for completeness. This type of validity seeks to determine if the tool was constructed adequately by reviewing the rational basis for the tool and the underlying principles that went into its construction. The evidence for content validity is logical rather than statistical.

Concurrent validity is based on how well the outputs of the tool under evaluation corresponds to outputs or predictions of other tools designed to address the same domain. Concurrent validity is a type of criterion-related validity. Studies of criterion validity assess the simultaneous relationship between the tool and a criterion.

Predictive validity is how well the tool serves a predictive purpose. This type of validity is used for the purpose of forecasting. This is an important type of validation for a modeling tool. Predictive validity is also a form of criterion-related validity. The purpose of a tool may be to predict the likelihood of succeeding on the criterion.

Construct validity is a necessary step when the content of the domain of interest is not clearly defined or when a criterion is not available which is accepted as adequate for the domain of interest. This type of validity is established through a series of activities in which a hypothetical construct is defined and a tool is simultaneously developed to measure it. Construct validation is an on-going process that involves assembling evidence to support the validity of the output generated by a tool.

SUMMARY

The goal of the study reported in this document is to initiate a multi-year program that will result in a set of systematic procedures for ensuring that HFE techniques are properly applied to military systems (with emphasis on aircraft crew stations) during the weapon system acquisition process. The approach taken is to identify and validate HFE tools of various kinds, tools that DOD HFE practitioners can use to assist them throughout this process. What tools are to be used, when to use them, and how to use the outputs must be specified.

Assumptions on which this study is based include the following.

1. Useful tools for crew station analysis, design, and evaluation are needed to achieve effective crew station integration.
2. A variety of potentially useful crew station analysis, design, and evaluation tools currently exist or are under development.
3. Assessment of specific tool utility and validity has been minimal so far.

During the first phase of this study, a detailed literature review was carried out to determine (1) what previous surveys of HFE tools had been made and the results of these surveys, (2) what things should be considered in setting up a taxonomy of HFE tools, and (3) what tool evaluation and validation methods have been proposed and used for other projects.

A HFE Procedures Taxonomy was developed, based on (1) the five phases of the weapon system acquisition process in which the tools might be used, and (2) the 115 HFE procedures or tasks identified for this study that may be carried out during one or more of the acquisition phases and with which the tools might be helpful. Implemented as an EXCEL spreadsheet, the taxonomy includes 4 attributes for each of the 115 HFE procedures: (1) the organizational level at which it usually is applied, (2) resources currently available to assist with the procedure usually is included, and (4) the types of military systems for which the procedure is applicable.

A HFE Tools Taxonomy database has been partially implemented, based on the Procedures Taxonomy. This database includes 12 attributes for each tool, in addition to the 4 attributes of the procedure to which the tool applies.

During this study a number of existing or nearly-complete HFE tools have been identified as potential candidates for evaluation and validation during the next phase of this study. These tools are described in this report.

Tool evaluations and validations are critical components of this project. Tools may be evaluated to determine whether they appear to be useful. This is done through subjective analysis based on written reviews, on conversations with persons who have used them, and on personal experience, to determine general ease of use, costs, what inputs are

required, what outputs are provided, etc. This is the process being used to determine which tools to validate.

Validation is necessary to determine the extent to which the tools actually measure or do what was intended. Validation requires the use of testing techniques such as (1) experimental studies, (2) non-experimental systematic comparisons, and (3) systematic violation of the assumptions on which the tool is based. The validation process that will be used to test the tools identified as promising candidates is described.

REFERENCES

- Apple Computer, Inc. (1988). HyperCard User's Guide. Cupertino, CA
- Baker, C., Johnson, J., Malone, M., & Malone, T. (1979). Human Factors Engineering for Navy Weapon System Acquisition. Essex Corp., Alexandria, VA
- Binder, L., Wang, A., & Merriman, S. (1988). SAMMIE as a Crew Station Accommodation Design Tool. McDonnell Douglas, St. Louis. MO
- Christ, R., Conroy, J., and Robertson, R. (1989). Crew Requirements Definition System (CRDS). In Proceedings of the Twenty-eighth Army Operations Research Symposium. Alexandria, VA: US Army Operational Test and Evaluation Agency (in press)
- Chubb, G., Stodolsky, N., Fleming, W., & Hassoun, J. (1987). STALL: A Simple Model for Workload Analysis in Early System Development. In Proceedings of the Human Factors Society-31st Annual Meeting (pp. 363-367). Santa Monica, CA: The Human Factors Society
- Cody, W. & Rouse, W. (1989). A Test of Criteria Used to Select Human Performance Models. In McMillan, G., Beevis, D., Salas, E., Strub, M., Sutton, R., & Van Breda, L. (Eds.), Applications of Human Performance Models to System Design. New York: Plenum
- Dunn, R. (1989). Anthropometric Computer Aided Design System (ACADS), Phase I Report. Naval Air Test Center, Patuxent River, MD
- Elkind, J. I., Card, S. K., Hochberg, J., & Messick Huey, B. (Eds.). (1989). Human Performance Models for Computer-Aided Engineering. National Academy Press, Washington, DC
- Fleger, S., Permenter, K., & Malone, T. (1987). Advanced Human Engineering Tool Technologies. Carlow Assoc., Inc., Fairfax, VA
- Harris, R. and Iavecchia, H. (1984). Crewstation Assessment of Reach Revision IV (CAR-IV) User's Guide. Analytics Technical Report 1800.06B, Willow Grove, PA
- Merriman, S. (1986). Human Factors Engineering Automated Project Planner. Naval Air Development Center, Warminster, PA.
- McConville, J.T., Case, H.W., and Clauser, C.E. (1989). An Assessment of the Automated Anthropometric Data Measuring System (AADMS). Anthropology Research Project, Inc.
- Miller, D. and Stone, A. (1989). ProtoTymer 1.0. Sandia National Laboratories, Albuquerque, NM
- Pew, R., Baron, S., Feehrer, C., & Miller, D. (1977). Critical Review and Analysis of Performance Models Applicable to Man-Machine Systems Evaluation. Bolt, Barenek and Newman Inc., Cambridge, MA

- Rouse, W. & Cody, W. (1989). Designer's Criteria for Choosing Human Performance Models. In McMillan, G., Beevis, D., Salas, E., Strub, M., Sutton, R., & Van Breda, L. (Eds.), Applications of Human Performance Models to System Design. New York: Plenum
- U.S. Department of Defense, Aircrew Station Geometry for Military Aircraft, MIL-STD-1333B, 9 January 1987, 5-6.
- U.S. Department of Defense, Human Engineering Design Criteria for Military Systems, Equipment and Facilities, MIL-STD-1472D, 14 March 1989.
- Virtual Prototypes, Inc. (1988). VAPS Product Overview. Canada
- Wherry, R. J., Jr. (1990). Human Engineering Tools Package. (Available from The Robert J. Wherry, Jr., Company, 562 Mallard Dr., Chalfont, PA 18914)
- Wickens, C.D., (1984) Engineering Psychology and Human Performance. Columbus, OH: C. E. Merrill Publishing Co.

NADC-91038-60

APPENDIX A

HFE Procedures Table

The following Taxonomy of Human Factors Engineering Procedures tables are taken from the HFE Tools Taxonomy data files. The tables list the HFE Procedures that may be carried out during the military system acquisition process. The procedures are listed in the tables as a function of the system acquisition phase or phases during which they are most likely to be used, and in the approximate order in which they might be carried out during that acquisition phase. Not all procedures are used for all projects. The tables are part of data files prepared for this study with the Microsoft EXCEL spreadsheet program.

Notes for Table Entries

Task No.

These numbers represent the approximate sequence in which the HFE Procedures might be carried out in a normal (large-size) project. These numbers are used only for reference and for database sorting.

Acq. Phs.

The military system acquisition phase or phases during which the HFE Procedure normally is applied are identified as follows.

- P HFE Procedure carried out Pre-Milestone 0, during the Mission Element Needs Statement development and mission analysis phase.
- 0 HFE Procedure used following Milestone 0, during the concept or program initiation phase.
- 1 HFE Procedure carried out following Milestone 1, during the demonstration and validation phase.
- 2 HFE Procedure carried out following Milestone 2, during the full-scale engineering development phase.
- 3 HFE Procedure carried out following Milestone 3, during the system production and deployment phase.

Org. Level

Four organization levels are identified at which the various HFE Procedures (tasks) usually are carried out (based on Merriman, 1986):

- Acq Major milestones and events associated with weapon system acquisition that drive all other tasks. These tasks generally are the responsibility of the system Program Manager (PMA).

Mgt SYSCOM-level tasks (NAVAIR, NAVSEA, etc.) which drive contractor and laboratory efforts. For crew stations, these tasks generally are the responsibility of AIR-5313.

Cntr Tasks usually (but not always) carried out by the contractor.

Lab Tasks usually (but not always) carried out by the Navy support laboratories.

HFE Procedure

This is a standard procedure, task, or technique that may be used at some point during the acquisition process to improve the human factors engineering of the system being acquired.

HFE Resources

Resources are existing documents or other aids commonly used to carry out this HFE Procedure.

Proj. Size

The size of the project for which this HFE Procedure commonly is used (most procedures are not cost-effective for small projects) is identified as follows.

Lge A large program, such as a new aircraft or man-in-the-loop missile.

Med A medium-size program, such as a major aircraft modification (procedures identified here as appropriate for "Med" projects are also carried out for "Lge" projects).

Sml A small project such as a minor aircraft modification (procedures identified here as appropriate for "Sml" projects are also carried out for "Med" and "Lge" projects).

Milit. System

The kind of military system to which this HFE Procedure applies is identified here: shipboard, subsurface, aircraft, ground vehicle, weapon system, etc. Most of the procedures are applicable to all military platforms and systems, but a few are identified as specific to aircraft programs.

No. of Tools

Tools are systems or devices that can be used to assist a human factors researcher or engineer in carrying out this HFE Procedure. The quantity of existing tools that have been identified to date for this procedure are noted here.

NADC-91038-60

Taxonomy of Human Factors Engineering Procedures

Task No.	Acq. Phs.	Org. Level	HFE Procedure	HFE Resources	Proj. Size	Milit. System	No. of Tools
1	P	Acq	MENS Preparation		Med	All	
2	P,0	Mgt	Define HFE Issues/Risks		Med	All	
3	P,0	Mgt	Review Similar Projects		Med	All	
4	P,0	Mgt	Cost/Benefit Analysis		Med	All	
5	P,0	Lab	Experimental Studies		Sml	All	
6	P,0	Lab	Data Analysis		Sml	All	

Task No.	Acq. Phs.	Org. Level	HFE Procedure	HFE Resources	Proj. Size	Milit. System	No. of Tools
7	0	Acq	Concept Studies		Med	All	1
8	0	Mgt	Manpower Constraints		Med	All	
9	0	Acq	Dem/Val SOW	MIL-STD-962	Med	All	1
10	0	Acq	Evaluate Dem/Val Proposals		Med	All	
11	0	Acq	System Concept Paper		Med	All	
12	0	Mgt	Plan Project Management	MIL-H-46855	Sml	All	2
13	0	Mgt	Coordinate Lab Support Requirem'ts		Sml	All	1

NADC-91038-60

Taxonomy of Human Factors Engineering Procedures

Task No.	Acq. Phs.	Org. Level	HFE Procedure	HFE Resources	Proj. Size	Milit. System	No. of Tools
14	1	Lab	Prepare Task Agreements		Med	All	
15	1	Lab	Literature Reviews	CSERIAC	Med	All	
16	1	Lab	Investigate Risk Areas		Lge	All	
17	1	Lab	Concept Investigations		Med	All	
18	1	Acq	FSD SOW	MIL-STD-962	Med	All	
19	1,2	Cntr	Draft HE Program Plan	DI-HFAC-80740	Sml	All	
20	1,2	Mgt	Review HE Program Plan	DI-HFAC-80740	Sml	All	
21	1,2	Mgt	HE Program Review		Med	All	
22	1,2	Cntr	Mission Analysis	MIL-H-46855	Med	All	
23	1,2	Mgt	Mission Analysis Review	MIL-H-46855	Med	All	
24	1	Cntr	Functional Analysis	MIL-H-46855	Med	All	
25	1,2	Cntr	Function Allocation	MIL-H-46855	Med	All	
26	1	Mgt	Performance Requirements		Med	All	
27	1,2	Cntr	Manpower Requirements		Med	All	1
28	1,2	Mgt	Review Manpower Requirements		Med	All	1
29	1,2	Mgt	Multicrew Coordination Requirem'ts		Med	All	
30	1	Cntr	Dynamic Simulation Plan	DI-HFAC-80742	Lge	Aircft.	
31	1	Mgt	Review Dynamic Simulation Plan	DI-HFAC-80742	Lge	Aircft.	
32	1	Cntr	HE Test Plan	DI-HFAC-80743	Med	All	2
33	1	Mgt	Review HE Test Plan	DI-HFAC-80743	Med	All	2
34	1	Cntr	Information Analysis		Med	All	1
35	1	Cntr	Equipment Identification	MIL-STD-1472	Sml	All	
36	1,2	Cntr	Draft HESAR	DI-HFAC-80745	Lge	All	
37	1,2	Mgt	Review HESAR	DI-HFAC-80745	Lge	All	
38	1,2	Cntr	Gross Task Analysis	HEL TM 13-87	Sml	All	
39	1	Cntr	Preliminary Workstation Layout	MIL-STD-1472	Sml	All	
40	1	Cntr	Crewstation Mockups	PMTC TP-80-10	Lge	All	
41	1	Lab	Crewstation Review Procedure		Med	All	
42	1,2	Mgt	Crewstation Design, Review		Med	Aircft.	
43	1	Acq	1st Dem/Val Design Review		Med	All	
44	1,2	Cntr	Design Displays/Controls	MIL-STD-1472	Sml	All	3
45	1,2	Mgt	Review Displays/Controls	MIL-STD-1472	Sml	All	4
46	1	Acq	2nd Dem/Val Des. Review		Med	All	
47	1	Acq	Final Dem/Val Reports		Med	All	
48	1,2	Cntr	Draft HEDAD-O	DI-HFAC-80746	Med	All	
49	1,2	Mgt	Review HEDAD-O	DI-HFAC-80746	Med	All	
50	1,2	Cntr	Critical Task Analysis	DI-H-7055	Med	All	
51	1,2	Mgt	Review Critical Task Ana.	DI-H-7055	Med	All	
52	1	Mgt	Maintenance Mockup		Med	All	1
53	1,2	Cntr	Draft HEDAD-M	DI-HFAC-80747	Lge	All	
54	1,2	Mgt	Review HEDAD-M	DI-HFAC-80747	Lge	All	
55	1	Cntr	Maintainer Critical Task Analysis	DI-H-7055	Lge	All	
56	1	Mgt	Review Maint. Critical Task Analysis	DI-H-7055	Lge	All	
57	1,2	Cntr	HE Progress Report	DI-HFAC-80741	Med	All	
58	1,2	Mgt	Review HE Progress Report	DI-HFAC-80741	Med	All	

NADC-91038-60

Taxonomy of Human Factors Engineering Procedures

Task No.	Acq. Phs.	Org. Level	HFE Procedure	HFE Resources	Proj. Size	Milit. System	No. of Tools
59	2	Mgt	Design Tradeoff Studies		Lge	All	
60	2	Mgt	Resolve Conflicting Reqts.		Med	All	
61	2	Mgt	Set Up ASAP Team	NAVAIRINST 5420.3:	Lge	Aircft.	
62	2	Cntr	Job Descriptions		Med	All	
63	2	Cntr	Manpower Estimates		Med	All	5
64	2	Mgt	Review Manpower Est.		Med	All	5
65	2	Cntr	Manpower/Training Tradeoffs		Med	All	
66	2	Mgt	Review Manpower/Training Trades		Med	All	
67	2	Cntr	Time line/link analysis		Med	All	
68	2	Cntr	Workload Analysis	MIL-H-46855	Sml	All	9
69	2	Cntr	Anthropometry	MIL-STD-1472	Med	All	10
70	2	Cntr	System Modeling	MIL-STD-1472	Lge	All	
71	2	Cntr	Define Operator-System Interface	MIL-STD-1472	Med	All	1
72	2	Mgt	Review Operator-System Interface	MIL-STD-1472	Med	All	1
73	2	Cntr	Workstation Layout	MIL-STD-1472	Sml	All	4
74	2	Mgt	Review Workstation Lay.	MIL-STD-1472	Sml	All	
75	2,3	Cntr	Conduct Dynamic Simulations		Lge	Aircft.	
76	2,3	Mgt	Review Dynamic Simulations		Lge	Aircft.	
77	2	Cntr	Define Maintainer-System Interface	AD-1410	Med	All	2
78	2	Mgt	Review Maintainer-System Interface	AD-1410	Med	All	2
79	2,3	Cntr	Safety Assessment		Sml	All	
80	2,3	Mgt	Review Safety Assessment		Sml	All	
81	2,3	Cntr	Health Hazard Assesment		Sml	All	
82	2,3	Mgt	Rev.iew Health Hazard Assessment		Sml	All	
83	2	Mgt	Preliminary Design Review		Med	All	
84	2	Mgt	Critical Design Review		Med	All	
85	2	Cntr	Human Reliability Prediction		Lge	All	
86	2	Mgt	Review Human Reliability Prediction		Lge	All	
87	2	Lab	Lighting Review Procedure		Med	Aircft.	
88	2	Mgt	Crewstation Lighting Review		Med	Aircft.	
89	2	Mgt	Detail Design Review		Med	All	
90	2	Lab	Night Lighting Review Procedure		Med	Aircft.	
91	2	Mgt	Night Lighting Review		Med	Aircft.	
92	2	Cntr	System Performance Predictions		Med	All	1
93	2	Mgt	Review System Performance Predict.		Med	All	1
94	2	Mgt	Developmental Testing		Med	All	
95	2	Cntr	HE Test Report	DI-HFAC-80744	Med	All	
96	2	Mgt	Review HE Test Report	DI-HFAC-80744	Med	All	
97	2	Cntr	Operator Training Plan		Med	All	1
98	2	Mgt	Review Operator Training Plan		Med	All	1
99	2	Cntr	Prepare Users Manuals		Med	All	1
100	2	Mgt	Review Users Manuals		Med	All	1
101	2	Cntr	Maintainer Training Plan		Lge	All	1
102	2	Mgt	Review Maintainer Training Plan		Lge	All	1

NADC-91038-60

Taxonomy of Human Factors Engineering Procedures

Task No.	Acq. Phs.	Org. Level	HFE Procedure	HFE Resources	Proj. Size	Milit. System	No. of Tools
103	3	Acq	TECHEVAL		Med	All	
104	3	Acq	OPEVAL		Med	All	
105	3	Mgt	Document T&E Deficiencies		Med	All	
106	3	Lab	T&E Deficiency Corrections		Med	All	
107	3	Mgt	Define Product Improvements		Med	All	
108	3	Lab	Functional Configuration Audit		Lge	All	
109	3	Lab	Physical Configuration Audit		Lge	All	
110	3	Lab	Analyze Hardware Trouble Reports		Med	All	
111	3	Lab	Analyze Software Trouble Reports		Med	All	
112	3	Mgt	Prepare Eng. Change Proposals	MIL-STD-480	Med	All	
113	3	Lab	Review Eng. Change Proposals	MIL-STD-480	Med	All	
114	3	Acq	Production Readiness Review		Med	All	
115	3	Acq	Production SOW	MIL-STD-962	Med	All	

NAJC-91038-60

APPENDIX B

TOOL TYPES AND THE HFE TASKS THAT THEY SUPPORT

1. HFE Principles, Standards, Specifications
 - a. Apply HFE criteria & principles
2. HFE Data Base
 - a. Review/summarize the results of previous research
3. HFE Acquisition Support
 - a. Program planning
 - b. Specify design requirements
 - c. Develop work statements
 - d. Develop data requirements
 - e. Develop test requirements
4. System Analysis
 - a. Functional analysis
 - b. Function allocation
 - c. Comparability analysis
5. Task Analysis
 - a. Analyze tasks
 - b. Network analysis
6. Workload Assessment
 - a. Assess mental workload
 - b. Assess physical workload
7. Crewstation Layout
 - a. Design workspace environment (habitability)
 - b. Design crewstation parameters
 - 1) internal & external visibility
 - 2) lighting
 - 3) control/display arrangement

- 4) accessibility
- 5) life support features
- 6) escape features
- c. Prepare design mockups
- 8. Man-Modeling/Anthropometrics
 - a. Crewstation geometry
 - b. Anthropometric matrix preparation (design/test cases)
 - c. Crew accommodation assessment (crewstation mapping)
 - d. Aircrew life support systems design/user interface (e.g. oxygen mask)
 - e. Subsystem design/integration (e.g. ejection seat)
- 9. Hardware Design/Human-Equipment Interface (Operability and Maintainability)
 - a. Prepare specifications for hardware components
 - b. Develop mockups
 - c. Design of enclosure for hardware components
 - 1) weight, size
 - 2) layout of external features (control panel, indicators, handles)
 - 3) layout of internal components (remove/replace assemblies)
 - d. Rack design (location of equipment, accessibility)
 - e. Input and control device design
 - f. Display device design
 - g. Life support equipment
- 10. Software Design/Human-Computer Interface (Formats, Logic)
 - a. Prepare specifications for software
 - b. Develop prototype formats
 - c. Link formats to assess logical flow

11. Test & Evaluation

- a. Verify design conformance to specifications (design criteria checklist). Evaluation categories include:
 - 1) Design (e.g., workspace and anthropometrics)
 - 2) Performance (e.g., human error evaluation)
 - 3) Maintainability (e.g., accessibility)
 - 4) Habitability (e.g., noise measurements)
- b. Demonstrate conformance to system, equipment, and facility design criteria (specifications, drawings)
- c. Confirm compliance with performance requirements where the operator or maintainer is a significant part of such system performance
- d. Obtain quantitative measures of system performance which are a function of man-machine interaction
- e. Determine if undesirable design or procedural aspects have been introduced

DISTRIBUTION LIST
Report No. NADC-91038-60

No. of Copies

Naval Air Systems Command.....	8
Washington, D.C. 20361	
(6 for AIR-5313)	
(2 for AIR-546, CDR S. Harris)	
Naval Air Test Center.....	2
Patuxent River, MD 20670	
(2 for Code SY-724)	
Naval Weapons Center.....	5
China Lake, CA 93555	
(5 for Code 3152)	
Pacific Missile Test Center.....	2
Point Mugu, CA 93042	
(2 for Code 4004A)	
Naval Postgraduate School.....	5
Monterey, CA 93940	
(5 for Code OR/Li)	
Defense Technical Information Center.....	2
Cameron Station, Bldg. 1	
Alexandria, VA 22314	
Naval Air Development Center.....	30
Warminster, PA 18974	
(2 for Code 8131)	
(2 for Code 6021)	
(4 for Code 60B5)	
(22 for Code 6022)	