

2

NAVAL POSTGRADUATE SCHOOL

Monterey, California

AD-A247 254



DTIC
ELECTE
MAR 12 1992
S B D

THESIS

EXPERIMENTAL RESULTS FOR INDUCTIVE STRIPS
IN INHOMOGENEOUS FINLINE

by
John Muir
September 1991

Thesis Advisor: Jeffrey B. Knorr

Approved for public release; distribution is unlimited

92 3 10 149

92-06406

Unclassified

security classification of this page

REPORT DOCUMENTATION PAGE				
1a Report Security Classification Unclassified		1b Restrictive Markings		
2a Security Classification Authority		3 Distribution Availability of Report Approved for public release; distribution is unlimited.		
2b Declassification Downgrading Schedule				
4 Performing Organization Report Number(s)		5 Monitoring Organization Report Number(s)		
6a Name of Performing Organization Naval Postgraduate School		6b Office Symbol <i>(if applicable)</i> 32	7a Name of Monitoring Organization Naval Postgraduate School	
6c Address <i>(city, state, and ZIP code)</i> Monterey, CA 93943-5000		7b Address <i>(city, state, and ZIP code)</i> Monterey, CA 93943-5000		
8a Name of Funding Sponsoring Organization		8b Office Symbol <i>(if applicable)</i>	9 Procurement Instrument Identification Number	
8c Address <i>(city, state, and ZIP code)</i>		10 Source of Funding Numbers		
		Program Element No	Project No	Task No
		Work Unit Accession No		
11 Title <i>(include security classification)</i> EXPERIMENTAL RESULTS FOR INDUCTIVE STRIPS IN INHOMOGENEOUS FINLINE				
12 Personal Author(s) John P. Muir				
13a Type of Report Master's Thesis		13b Time Covered From To	14 Date of Report <i>(year, month, day)</i> September 1991	15 Page Count 66
16 Supplementary Notation The views expressed in this thesis are those of the author and do not reflect the official policy or position of the Department of Defense or the U.S. Government.				
17 Cosati Codes		18 Subject Terms <i>(continue on reverse if necessary and identify by block number)</i>		
Field	Group	Subgroup	finline, inductive strip, microwave, CAD, millimeter-wave	
19 Abstract <i>(continue on reverse if necessary and identify by block number)</i> <p>This thesis discusses some experimental results involving inductive strips in inhomogeneous finline. One resonator bandpass filters were constructed in inhomogeneous finline for $w/b = 1.0, 0.5, 0.2$ and 0.1 in X-Band waveguide. The frequency response of these filters was plotted using a scalar analyser and the resonant frequency and crossover bandwidth were measured. The results were compared to those obtained using spectral-domain programs and CAD models developed at the Naval Postgraduate School.</p>				
20 Distribution Availability of Abstract <input checked="" type="checkbox"/> unclassified unlimited <input type="checkbox"/> same as report <input type="checkbox"/> DTIC users		21 Abstract Security Classification Unclassified		
22a Name of Responsible Individual Jeffrey B. Knorr		22b Telephone <i>(include Area code)</i> (408) 646-2815	22c Office Symbol EC/Ko	

DD FORM 1473,84 MAR

83 APR edition may be used until exhausted
All other editions are obsolete

security classification of this page

Unclassified

Approved for public release; distribution is unlimited.

Experimental Results For Inductive Strips
In Inhomogeneous Finline

by

John P. Muir
Captain, Canadian Forces
BEng, Royal Military College of Canada, 1982

Submitted in partial fulfillment of the
requirements for the degree of

MASTER OF SCIENCE IN ELECTRICAL ENGINEERING

from the

NAVAL POSTGRADUATE SCHOOL
September 1991

Author:

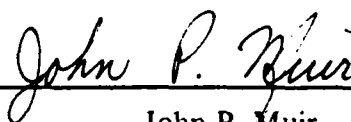

John P. Muir

Approved by:

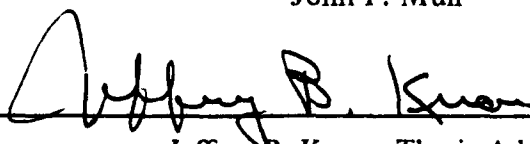

Jeffrey B. Knorr, Thesis Advisor

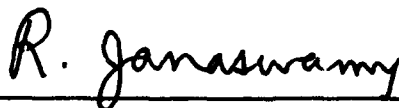

R. Janaswamy, Second Reader



Michael A. Morgan, Chairman,
Department of Electrical and Computer Engineering

ABSTRACT

This thesis discusses some experimental results involving inductive strips in inhomogeneous finline. One resonator bandpass filters were constructed in inhomogeneous finline for $w/b = 1.0, 0.5, 0.2$ and 0.1 in X-Band waveguide. The frequency response of these filters was plotted using a scalar analyser and the resonant frequency and crossover bandwidth were measured. The results were compared to those obtained using spectral-domain programs and CAD models developed at the Naval Postgraduate School.



Accession For	
NTIS GRA&I	<input checked="" type="checkbox"/>
DTIC TAB	<input type="checkbox"/>
Unannounced	<input type="checkbox"/>
Justification	
By _____	
Distribution/	
Availability Codes	
Dist	Avail and/or Special
A-1	

TABLE OF CONTENTS

I. INTRODUCTION	1
A. BACKGROUND	1
B. OBJECTIVE	2
II. FINLINE MODELS	4
A. HOMOGENEOUS FINLINE MODEL	4
B. INHOMOGENEOUS FINLINE MODEL	4
III. EXPERIMENTAL VERIFICATION	8
A. INTRODUCTION	8
B. APPARATUS	8
C. PROCEDURE	12
D. RESULTS	13
IV. DATA ANALYSIS	14
A. INTRODUCTION	14
B. MODELS	14
1. Model A and A1	14
2. Model B	15
C. FILTER RESONANT FREQUENCY	15
D. FILTER CROSSOVER BANDWIDTH	15
E. APPEARANCE OF FILTER FREQUENCY RESPONSE CURVE	16
F. ERROR ANALYSIS	17
1. Absolute Sweep Generator Error	18
2. Linear Sweep Generator Error	18
G. DIELECTRIC LOSSES	18
V. CONCLUSIONS AND RECOMMENDATIONS	21
A. CONCLUSIONS	21
B. RECOMMENDATIONS FOR FURTHER STUDY	21

APPENDIX A. MODEL A TOUCHSTONE CIRCUIT FILE	22
APPENDIX B. MODEL B TOUCHSTONE CIRCUIT FILE	25
APPENDIX C. FINLINE TAPER VALUES	29
A. W/B=0.1	29
B. W/B=0.2	29
C. W/B=0.5	30
APPENDIX D. TOUCHSTONE DATA FILES	31
A. W/B=0.1	31
1. Strip Length = 42.6 Mils	31
2. Strip Length = 46.5 mils	31
3. Strip Length = 82.1 mils	32
4. Strip Length = 83.9 mils	32
5. Strip Length = 125 mils	32
6. Strip Length = 127 mils	33
B. W/B=0.2	33
1. Strip Length = 52.7 mils	33
2. Strip Length = 54.1 mils	34
3. Strip Length = 102 mils	34
4. Strip Length = 103 mils	34
5. Strip Length = 151 mils	35
6. Strip Length = 152 mils	35
C. W/B=0.5	36
1. Strip Length = 101 mils	36
2. Strip Length = 102 mils	36
3. Strip Length = 149 mils	37
4. Strip Length = 151 mils	37
5. Strip Length = 200 mils	37
D. W/B= 1.0	38
1. Strip Length = 202 mils	38
2. Strip Length = 204 mils	38
3. Strip Length = 251 mils	39
4. Strip Length = 253 mils	39

5. Strip Length = 301 mils	39
APPENDIX E. FREQUENCY RESPONSE CURVES	41
LIST OF REFERENCES	53
INITIAL DISTRIBUTION LIST	55

LIST OF TABLES

Table 1.	FINLINE FILTER PARAMETERS	10
Table 2.	FINLINE FILTER EXPERIMENTAL RESULTS	13
Table 3.	RESONANT FREQUENCY: MODEL VERSUS EXPERIMENT	16
Table 4.	CROSSOVER BANDWIDTH: MODEL VERSUS EXPERIMENT ...	17

LIST OF FIGURES

Figure 1.	Inhomogeneous Finline with an Inductive Strip Mounted in a Shield . . .	2
Figure 2.	Finline Waveguide Fixture	9
Figure 3.	Typical Finline One Resonator Bandpass Filter	11
Figure 4.	Experimental Setup	12
Figure 5.	Dielectric Reflection and Transmission Coefficients	19
Figure 6.	Dielectric Transmission Coefficient	20
Figure 7.	Filter 1 Frequency Response from Experiment	41
Figure 8.	Filter 1 Frequency Response from Model A1	41
Figure 9.	Filter 2 Frequency Response from Experiment	42
Figure 10.	Filter 2 Frequency Response from Model A1	42
Figure 11.	Filter 3 Frequency Response from Experiment	43
Figure 12.	Filter 3 Frequency Response from Model A1	43
Figure 13.	Filter 4 Frequency Response from Experiment	44
Figure 14.	Filter 4 Frequency Response from Model B	44
Figure 15.	Filter 5 Frequency Response from Experiment	45
Figure 16.	Filter 5 Frequency Response from Model B	45
Figure 17.	Filter 6 Frequency Response from Experiment	46
Figure 18.	Filter 6 Frequency Response from Model B	46
Figure 19.	Filter 7 Frequency Response from Experiment	47
Figure 20.	Filter 7 Frequency Response from Model B	47
Figure 21.	Filter 8 Frequency Response from Experiment	48
Figure 22.	Filter 8 Frequency Response from Model B	48
Figure 23.	Filter 9 Frequency Response from Experiment	49
Figure 24.	Filter 9 Frequency Response from Model B	49
Figure 25.	Filter 10 Frequency Response from Experiment	50
Figure 26.	Filter 10 Frequency Response from Model B	50
Figure 27.	Filter 11 Frequency Response from Experiment	51
Figure 28.	Filter 11 Frequency Response from Model B	51
Figure 29.	Filter 12 Frequency Response from Experiment	52
Figure 30.	Filter 12 Frequency Response from Model B	52

ACKNOWLEDGEMENTS

I would like to thank my wife, Francyne, for her patience and understanding, my thesis advisor, Prof. Knorr, for his support and guidance, the Mechanical Engineering machine shop for manufacturing the fixture and the Naval Weapons Center at China Lake for etching the circuits.

I. INTRODUCTION

A. BACKGROUND

Finline is a transmission medium consisting of metal fins, printed on a dielectric substrate, mounted in the E -Plane of a waveguide. In this form it is called inhomogeneous finline. If the dielectric substrate is removed, it is referred to as homogeneous finline. Since it was first described by Meier in 1974 [Ref. 1], finline has become an important transmission medium at millimeter wave frequencies. An important structure in finline is the inductive strip. Inductive strips are vertical bifurcations joining the upper and lower fins together. Their principle use is as discontinuities in the construction of resonators in filters. Figure 1 on page 2 shows a typical inductive strip in finline.

The behaviour of finlines has been investigated extensively using various numerical techniques. One such technique which has been used successfully is the spectral-domain technique. Two computer programs have been developed using this technique to predict the behaviour of finline and inductive strips in finline. The computer program *IMPED* uses the spectral-domain technique to determine the wavelength and voltage-power impedance of a finline of arbitrary w/b and dielectric thickness. The program is described in Refs. 2, 3 and 4.

A computer program called *STRIP* uses the spectral-domain method to determine the scattering coefficients of an inductive strip in a finline. The final version of *STRIP* [Refs. 5 and 6] can handle inductive strips in inhomogeneous finline with $0 < w/b \leq 1.0$.

The results obtained with these programs have been used to develop models for finline, both homogeneous [Ref. 7: pp. 4-8] and inhomogeneous [Ref. 8] and for inductive strips in homogeneous finline [Ref. 7: pp. 22-28 and 9]. These models are required because although the spectral-domain programs give excellent results, they take a long time to execute. To obtain the results for one strip takes over an hour on a Sparc workstation for a simple case. As w/b decreases, the time required increases. The derived models have errors of less than 2.5 percent and execute rapidly in *Touchstone* a microwave circuit simulation package from *EEsof*.

The finline model replaces the finline by an equivalent waveguide with increased width and decreased height compared to the actual waveguide shield. The fields of the

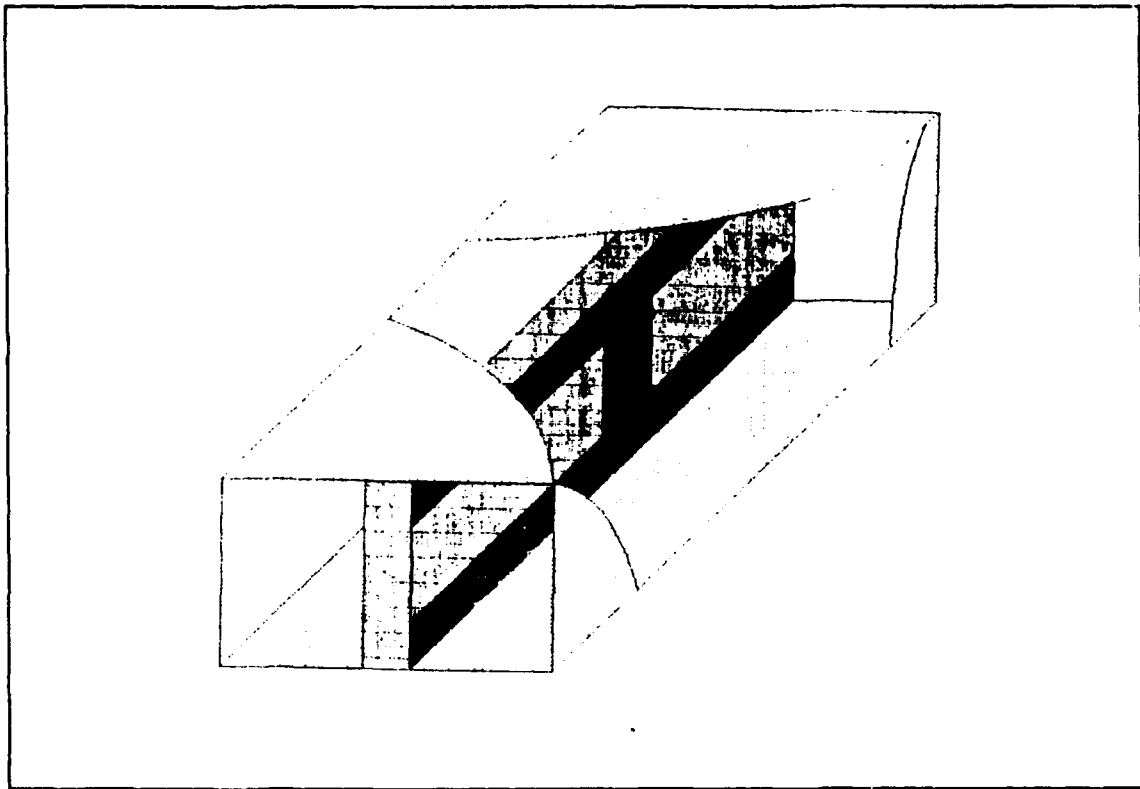

Figure 1. Inhomogeneous Finline with an Inductive Strip Mounted in a Shield: The shield is cut away to show the finline.

finline and the equivalent waveguide have the same wavelength and voltage-power impedance.

The basis of the inductive strip model is the modelling of the inductive strip as two parallel below-cutoff waveguides. This explanation has physical significance since a look at the strip discontinuity shows two side by side channels which appear like waveguides.

These models have been validated against the spectral-domain programs *IMPED* and *STRIP*. Experimental verification of actual finline circuits has been limited to the homogeneous case [Ref. 5: pp. 1014-1017] and [Ref. 10].

B. OBJECTIVE

The objective of this thesis is to describe experiments performed to confirm the validity of the spectral-domain programs which were used to develop the finline models described earlier, for the case of inductive strips in inhomogeneous finline. The model for inhomogeneous finline developed by Knorr and Grohsmeyer [Ref. 8] is used. The

successful results of the experiments will confirm the validity not only of the spectral-domain programs operating with dielectric but also the models derived from them. The data will be useful for the ongoing effort to develop a general model of an inductive strip in inhomogeneous finline.

II. FINLINE MODELS

A. HOMOGENEOUS FINLINE MODEL

Homogeneous finline contains no dielectric and can be thought of as a ridged waveguide where the ridge has infinitesimal width. This finline can be modelled using equivalent waveguides. When $w/b = 1.0$, the fin disappears and the structure becomes an ordinary waveguide. For $w/b < 1.0$ and with no dielectric present, the equivalent waveguide has dimensions a_{eq} and b_{eq} . These equivalent dimensions can be found in terms of the shield dimensions a and b and the finline width ratio w/b using:

$$\frac{a_{eq}}{a} = 2 - \sqrt{1 - \left(\frac{2b}{a}\right)^{0.77} \left(1 - \frac{w}{b}\right)^2} + 0.221 \left(\frac{2b}{a}\right)^{-3.61} \left(1 - \frac{w}{b}\right)^{28} \quad (1)$$

$$\frac{b_{eq}}{b} = 0.6 + \sqrt{0.16 - 0.1347 \left(\frac{2b}{a}\right)^{1.35} \left(1 - \frac{w}{b}\right)^2} - 0.170 \left(\frac{2b}{a}\right)^{-1.15} \left(1 - \frac{w}{b}\right)^{10} \quad (2)$$

Once the equivalent waveguide dimensions are known the wavelength within the finline can be found using:

$$\lambda' = \frac{\lambda_o}{\sqrt{1 - \left(\frac{\lambda_o}{2a_{eq}}\right)^2}} \quad (3)$$

The voltage power impedance is found using

$$Z_{ov} = \frac{\left(\frac{2b_{eq}}{a_{eq}}\right) 120\pi}{\sqrt{1 - \left(\frac{\lambda_o}{2a_{eq}}\right)^2}} \quad (4)$$

These relations have been discussed by both Knorr [Ref. 9] and Morua [Ref. 7].

B. INHOMOGENEOUS FINLINE MODEL

For the case where the finline is mounted on a dielectric substrate the finline is modelled by an equivalent waveguide homogeneously filled with some equivalent dielectric. The model for inhomogeneous finline is derived in Ref. 8. The finline wave-

length and voltage power impedance are found using similar equations as the homogeneous case except for the addition of a new parameter k_e , the effective relative permittivity of the equivalent waveguide homogeneously filled with dielectric. The formula for finline wavelength becomes:

$$\lambda' = \frac{\lambda_o}{\sqrt{k_e - \left(\frac{\lambda_o}{2a_{eq}}\right)^2}} \quad (5)$$

and the voltage power impedance is found using:

$$Z_{ov} = \frac{\left(\frac{2b_{eq}}{a_{eq}}\right) \frac{\eta_o}{\sqrt{k_e}}}{\sqrt{k_e - \left(\frac{\lambda_o}{2a_{eq}}\right)^2}} \quad (6)$$

The expressions for the equivalent waveguide dimensions are modified from those for homogeneous waveguide with $w/b < 1$. The expressions for the inhomogeneous finline equivalent dimensions are more complicated than those for homogeneous finline due to the need to include the effects of variable dielectric thickness. These new relations also include the effects of the waveguide shield height to width ratio. They are:

$$\frac{a_{eq}}{a} = 2 - \sqrt{1 - \left(\frac{b}{a} + .45\right)\left(1 - \frac{w}{b}\right)^2} + C_1\left(1 - \frac{w}{b}\right)^{.26} \quad (7)$$

where

$$C_1 = -4.9723\left(\frac{b}{a}\right)^2 + 4.7413\frac{b}{a} - .7651 \quad (8)$$

With a_{eq} known, the wavelength inside the finline can be calculated. Ref. 8 shows the error using this expression for the equivalent waveguide width to be less than two percent.

An analytic expression for b_{eq}/b proved to be more involved. The result presented in Ref. 8 is:

$$\left(\frac{b_{eq}}{b}\right)_{avg} = C_2 \left(1 - \frac{w \frac{2b}{a} C_3}{b}\right) + C_4 + C_5 \left[1 - \left(\frac{b}{a} - \frac{w}{b}\right)^2\right]^4 - 0.025 \left[1 - \left(0.925 - \frac{w}{b}\right)^2\right]^{16} \quad (9)$$

where for homogeneous finline,

$$C_2 = 0.1909 \frac{b}{a} - 0.705 \quad (10)$$

and for inhomogeneous finline

$$C_2 = \left[-115.79 \left(\frac{d}{a}\right)^2 + 27.87 \frac{d}{a} - 0.4933 \right] \frac{b}{a} + \left[87.52 \left(\frac{d}{a}\right)^2 - 22.49 \frac{d}{a} - 0.1932 \right] \quad (11)$$

The remaining constants are found using

$$C_3 = 0.29 + 0.0773e^{(1-40 \frac{d}{a})} \quad (12)$$

and

$$C_4 = \left[20.1154 \left(\frac{d}{a}\right)^2 - 3.5729 \frac{d}{a} - 0.0611 \right] \frac{b}{a} + \left[-26.1788 \left(\frac{d}{a}\right)^2 + 5.537 \frac{d}{a} + 1.0376 \right] \quad (13)$$

and

$$C_5 = \left[-13.5217 \left(\frac{d}{a}\right)^2 + 2.4017 \frac{d}{a} + 0.0411 \right] \quad (14)$$

The expression is fine tuned using

$$\frac{b_{eq}}{b} = m \left(\frac{freq}{f_c} - 1.56 \right) + \left(\frac{b_{eq}}{b} \right)_{avg} \quad (15)$$

where

$$m = C_6 \left(\frac{w}{b}\right)^2 + C_7 \left(\frac{w}{b}\right) + C_8 \quad (16)$$

and the coefficients are found using

$$C_6 = \left[-76.251 \left(\frac{d}{a} \right)^2 + 17.23 \frac{d}{a} - 0.1578 \right] \frac{b}{a} + \left[111.2 \left(\frac{d}{a} \right)^2 - 20.84 \frac{d}{a} + 0.1703 \right] \quad (17)$$

and

$$C_7 = \left[64.82 \left(\frac{d}{a} \right)^2 - 14.77 \frac{d}{a} - 0.3029 \right] \frac{b}{a} + \left[-107.1 \left(\frac{d}{a} \right)^2 + 22.85 \frac{d}{a} - 0.2936 \right] \quad (18)$$

and

$$C_8 = \left[9.696 \left(\frac{d}{a} \right)^2 - 1.449 \frac{d}{a} - 0.1431 \right] \frac{b}{a} + \left[-12.13 \left(\frac{d}{a} \right)^2 + 1.39 \frac{d}{a} + 0.1195 \right] \quad (19)$$

III. EXPERIMENTAL VERIFICATION

A. INTRODUCTION

The chief aim of this thesis is to produce experimental data for inductive strip discontinuities in inhomogeneous finline. Ideally the scattering coefficients of the inductive strips should be measured. Unfortunately, the measurement of the phase of the scattering coefficients of inductive strips mounted on a dielectric substrate is severely complicated by the need to establish a reference plane. The presence of the dielectric makes this nearly impossible. However, since the aim of the data is to verify the spectral-domain data and provide data to verify any models which are developed, it is possible to do this without directly measuring the scattering coefficients.

The approach which was selected was to develop a series of one resonator bandpass filters. These filters were fabricated on dielectric after which the dimensions were measured. The resulting dimensions are used as input into the models and programs to be tested. The frequency response of actual filters is compared to the frequency response of models of these same filters to determine the accuracy of the models, taking into account experimental error. Because a complete *Touchstone* model was not available in time to be incorporated, a partial model was used. The spectral-domain program *STRIP* is used to generate scattering coefficients for the inductive strips. These coefficients are entered directly into *Touchstone* to form part of the circuit. The inhomogeneous finline which forms the resonator and the rest of the structure is modelled using the techniques of Chapter II. Future models can be tested in a similar way by using them to develop models of the same filters and comparing their output to the experimental results.

B. APPARATUS

The use of finline requires a special fixture which is essentially a waveguide split along the *E*-Plane. To hold the finline a small groove is cut along one of the halves. The end view of the fixture is shown in Figure 2 on page 9. The groove is slightly narrower than the thickness of the dielectric plus metal so that when the two halves are joined together the dielectric will be compressed setting up good contact with the waveguide. This is the grounded version of finline, which is suitable for passive circuits such as the filters which will be used for this series of experiments. The fixture was manufactured by the machine shop from aluminium.

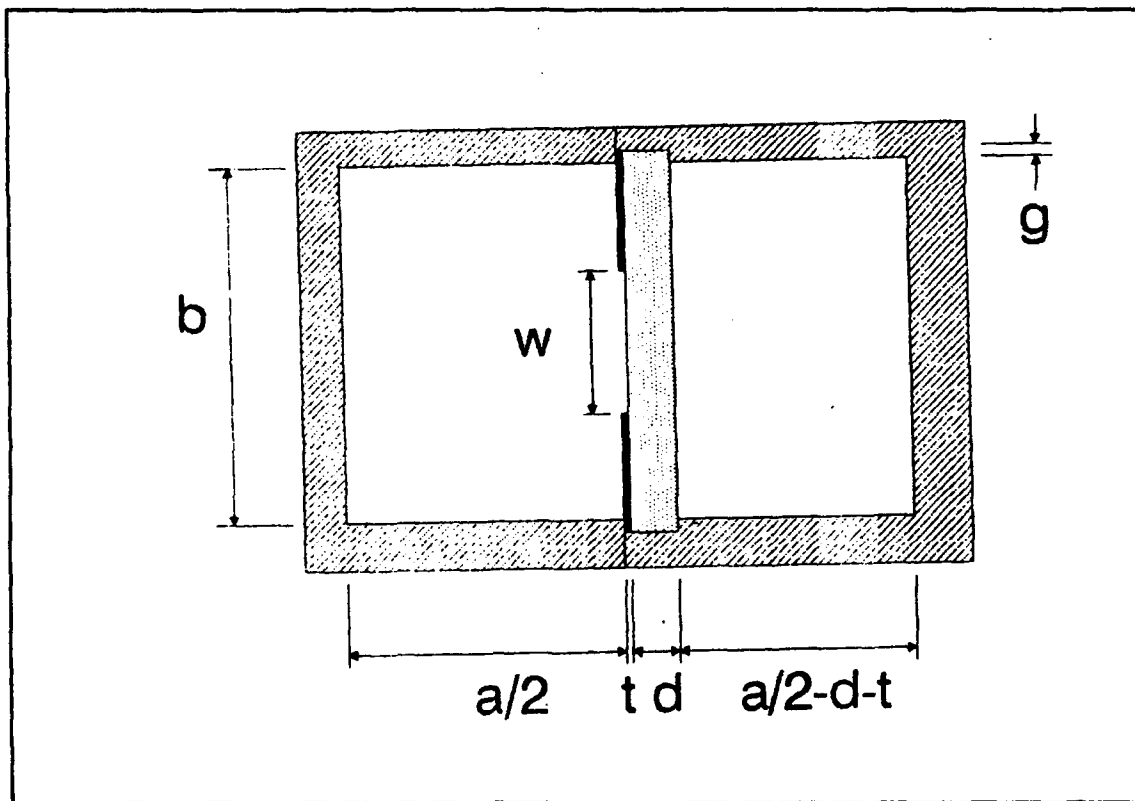

Figure 2. Finline Waveguide Fixture: The finline is inserted in the grooves as shown.

The fixture has a groove which is 29 mils wide. This was selected to hold a dielectric with a thickness of 31 mils \pm 1 mil. The metallization used is 1/2 oz. copper which corresponds to a thickness of less than one mil. With this configuration the maximum the dielectric will be compressed is four mils and the minimum is two mils. Trials with actual finline show that the material is held firmly in the fixture.

Filters were designed and built for a variety of w/b and inductive strip lengths. Experimentally it was observed that as w/b decreases, the effect of a given strip length increases, so for the smaller values of w/b shorter strip lengths were used. The minimum w/b is limited by the difficulty of fabricating the filter elements. This limitation is the result of using the *EEsof MICmask* program to cut out rubyolith using a diamond tipped cutting tool mounted in place of the pen on an HP7475A plotter. The *EEsof* documentation gives the maximum accuracy for the HP7475A plotter used in this manner as being 8 mils. The resulting rubyoliths were converted to negatives by the photo lab

and sent to the Naval Weapons Center, China Lake where they were etched on RT Duroid with $\epsilon_r = 2.22$ and a thickness of 31 mil \pm 1 mil. This material was chosen because it is commonly used for experimental work with finline and has been used in past work at the school. The programs being compared all use $\epsilon_r = 2.22$. A typical finline filter is shown in Figure 3 on page 11.

The design and measured dimensions of the filters that were manufactured are given in Table 1. The measurements were made using a travelling microscope in the Physics Department Optical Lab. The smallest microscope graduation is 0.01 mm or 0.4 mils. The actual measurements differ from the design measurements because of the limitations of the plotter. The resulting imperfections are carried over into the negative and the circuits which are manufactured by etching. The exception is for the circuits where $w/b = 0.1$. For these an attempt was made to touch up the negative because of the roughness of the edges. Despite this or perhaps because of this the edges of the finline are clearly uneven when viewed under a microscope, with irregularities up to 4 mils in size.

Table 1. FINLINE FILTER PARAMETERS

Filter #	Design Dimensions [mils]				Actual Dimensions [mils]			
	w/b	Strip 1	Resonator	Strip 2	w/b	Strip 1	Resonator	Strip 2
1	1.0	200	500	200	0.9879	204	492	202
2	1.0	250	500	250	0.9890	253	491	251
3	1.0	300	500	300	0.9820	301	493	301
4	0.5	100	500	100	0.4970	102	494	101
5	0.5	150	500	150	0.4888	151	492	149
6	0.5	200	500	200	0.4880	200	494	200
7	0.2	50	500	50	0.2027	54.1	493	52.7
8	0.2	100	500	100	0.1928	102	492	103
9	0.2	150	500	150	0.1991	152	493	151
10	0.1	40	500	40	0.0989	42.6	492	46.5
11	0.1	80	500	80	0.0876	82.1	491	83.9
12	0.1	120	500	120	0.0860	125	490	127

The experimental setup is shown in Figure 4 on page 12. The waveguide fixture is connected to the scalar analyzer via coaxial cable and coaxial line to waveguide adapters.

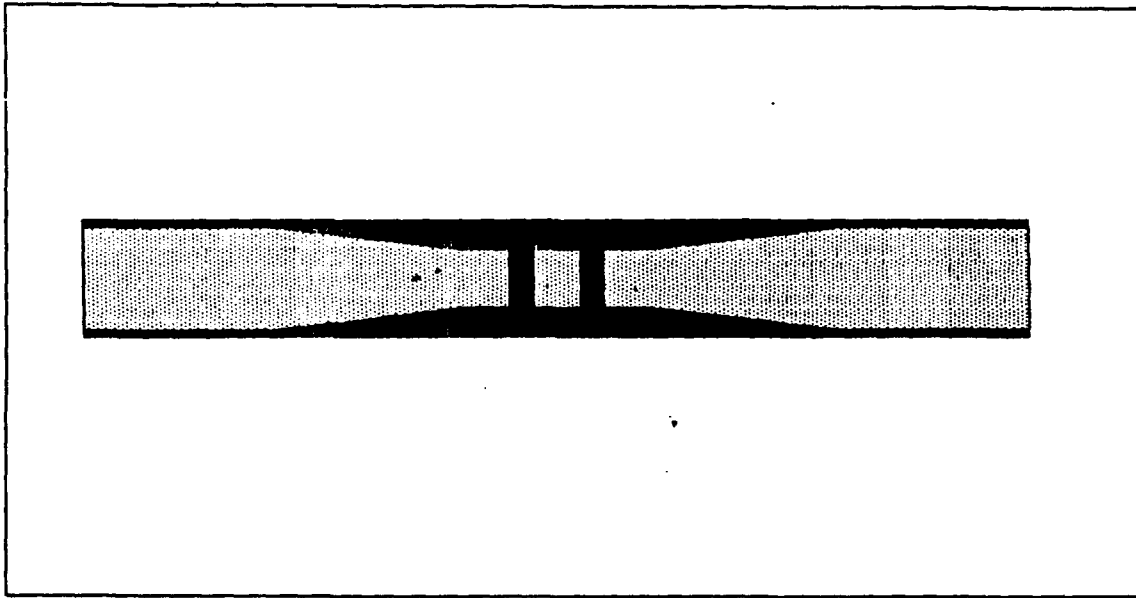

Figure 3. Typical Finline One Resonator Bandpass Filter: The width of the strips is denoted by T .

The adapters couple power in and out of the waveguide and provide impedance matching via a multi-step transformer. The scalar analyzer measures the magnitude of the insertion loss and the reflection loss by taking a sample of the input power as a reference and comparing the reflected and transmitted power to the reference to obtain the insertion and reflection loss. By employing incoherent detection of the transmitted and reflected energy, the phase information is lost, but the equipment is simplified and the experimental procedure is also simpler. In order to obtain accurate results calibration is important.

The scalar analyzer controls a sweep generator with an RF plug-in which generates the actual RF energy. The accuracy of this RF generator controls the accuracy of the frequency measurements. The scalar analyzer has 400 bins in which it can store magnitudes for the reflected and transmitted energy. The frequency increment represented by each bin depends on the total frequency sweep range. Results were obtained with the frequency swept from 8 to 12 GHz and over a one GHz range centered on the resonant frequency. The plots resulting from the four GHz sweeps are included for comparison with the model results, while the one GHz sweeps were used to make the resonant frequency and crossover bandwidth measurements.

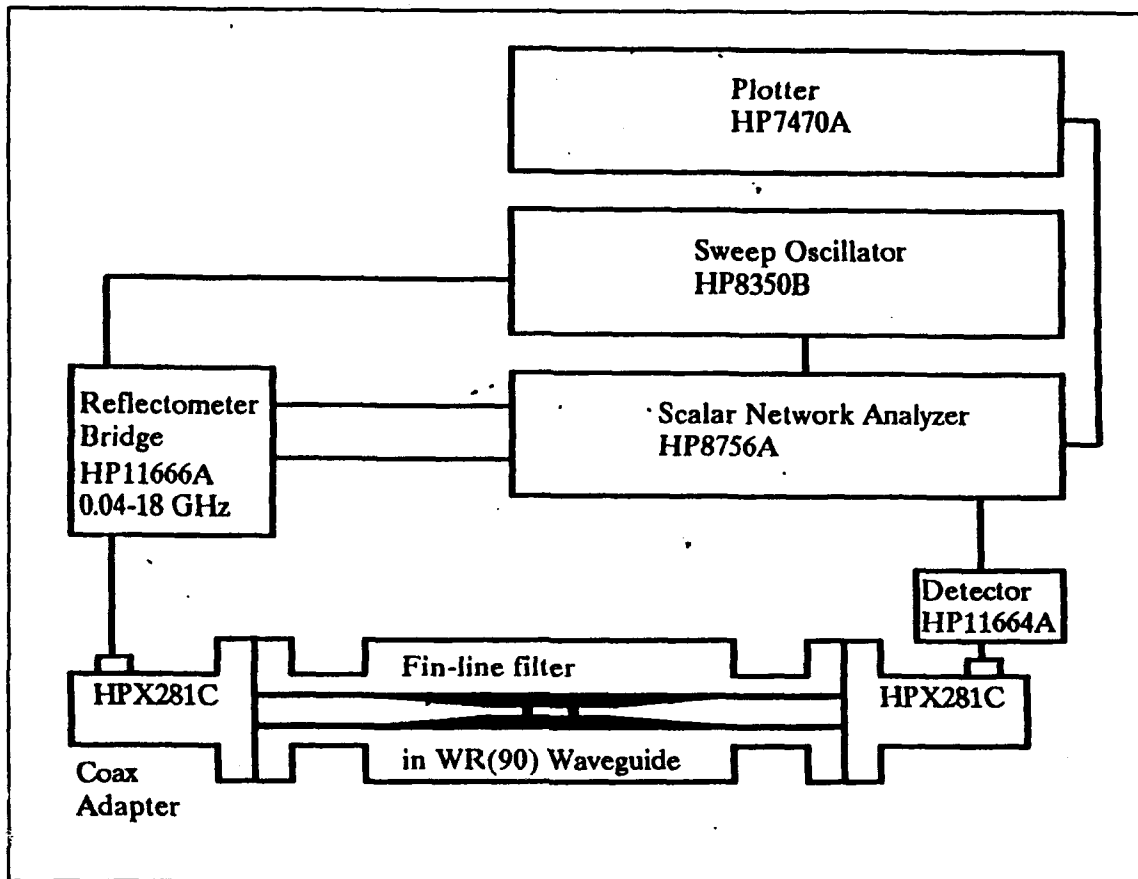

Figure 4. Experimental Setup

C. PROCEDURE

In order to measure the response of the filter and not the equipment, the analyzer must first be calibrated with the test fixture removed. Calibration is performed by finding the reflection loss for a short and for an open and storing them in memory. Since the short and open provided attach to the coaxial connector of the bridge, the response of the coaxial to waveguide adapters is not accounted for. To calibrate the insertion loss the response without the fixture is measured and stored in memory. The output measurement is the actual measurement less the stored measurement. The experimental procedure that is followed for each of the filters is:

1. Calibrate channel one of the scalar analyzer using a short and an open.
2. Calibrate channel two by connecting the input to the output without the waveguide fixture and store the result in memory.
3. Insert the fixture with the finline filter installed into the circuit.

4. Measure response of the filter from 8 to 12 GHz.
5. Set cursor on the minimum value of channel one which is considered to be the resonant frequency.
6. Plot this output.
7. Select a one GHz range which has the resonant frequency at the center.
8. Remove the fixture and recalibrate the analyzer.
9. Reinsert the fixture and measure the response.
10. Using the cursor controls measure the 3 dB bandwidth between crossover points and the resonant frequency.
11. Plot the response curve.

D. RESULTS

The values of f_0 and Δf , measured using the technique described in the previous section, are shown in Table 2. The curves themselves can be seen in Appendix E. The effects of loss are clearly apparent with all the filters having a minimum insertion loss greater than 0 dB. The minimum value varies from 0.59 dB to 1.93 dB. The possible source of some of this loss is discussed in the next chapter.

Table 2. FINLINE FILTER EXPERIMENTAL RESULTS

Filter #	Measured Results	
	f_0 [GHz]	Δf [MHz]
1	10.040	350
2	10.012	218
3	9.9975	142.50
4	9.9175	462.50
5	9.9025	295.0
6	9.8725	204.9
7	9.6724	424.99
8	9.7300	234.99
9	9.7150	132.49
10	9.5525	290
11	9.645	147.6
12	9.6824	70

IV. DATA ANALYSIS

A. INTRODUCTION

The data analysis performed consists of comparing the experimental results with various models for the finline filter. The following are compared:

1. resonant frequency f_0 ,
2. crossover bandwidth Δf and
3. appearance of the response curve.

The last is somewhat subjective and plots of the experimental results and the model results are included to permit the reader to make his own judgements.

Since the models being used for comparison do not include loss, the curves of insertion loss determined experimentally will not approach 0 dB as closely as those generated by the models. The models also generate much smaller minimums for the Return Loss at resonance.

To make the comparison as accurate as possible, the actual dimensions of the filters were used as input to the spectral-domain program *STRIP*. The resulting scattering coefficients were inserted into *Touchstone* data files. The *Touchstone* program takes the scattering coefficients contained in these data files and incorporates them into the total circuit model. The equivalent waveguide model is used for the inhomogeneous finline which forms the resonator and the remainder of the structure. The combined model is only as accurate as its two components.

B. MODELS

Two main models are being compared, Model A and Model B. The main difference between the two is that Model A uses a termination for the structure which has the same impedance as the finline while Model B attempts to use a more realistic termination.

1. Model A and A1

The *Touchstone* circuit file incorporating Model A is included as Appendix A. The model is as described above, with the termination given by the RWGT statement. For Model A this is set equal to the same values as the finline. This assumes that the finline structure is perfectly matched to the measurement apparatus, which is not true since the actual finline structure has a discontinuity where the dielectric ends abruptly at the edge of the waveguide fixture. Model A1 is a variation of Model A used only with

$w/b = 1.0$ that replaces the ideal finline termination with an air filled full height rectangular waveguide. The only line of Model A1 which differs from Model A as shown in Appendix A is the RWGT statement which has the arguments $A^A B^B ER=1 RHO=0$. There are other discontinuities such as those in the waveguide to coaxial adapter but no attempt was made to quantify or model them.

2. Model B

Model B attempts to model the finline taper which was used in the actual filters when w/b was less than one. The taper is modelled with a series of steps of steadily decreasing w/b . The waveguide termination is an air filled full height rectangular waveguide as for Model A1. Because the taper dimensions and equivalent permittivities must be computed externally, three separate *Touchstone* model files are needed. The files are identical however except for the taper values and w/b . One example of the circuit file is included as Appendix B. The three different tapers are included as Appendix C. The *Touchstone* data files which contain the scattering data used for all of these models are included as Appendix D.

C. FILTER RESONANT FREQUENCY

The experimental resonant frequency measurements are compared to the model results in Table 3 on page 16. The agreement between the experimental results and the model results is excellent with the largest error being 0.76%.

Interestingly, the results from the models with the more realistic termination do not always give the closer agreement. The differences between the models is slight however. This indicates that the phase accuracy of the models and spectral-domain programs is very good and that the effects of the model which is external to the actual filter are slight. Since the presence or absence of loss has very little effect on the phase behaviour of the models, the fact that loss is not taken into account in the models is not critical with respect to the resonant frequency obtained.

D. FILTER CROSSOVER BANDWIDTH

The bandwidth measurement being used for comparison between experiment and model is the bandwidth between the two crossover points. The crossover points are where the insertion loss curve and the return loss curve intersect. If the filter is lossless, these two points correspond to the 3 dB points of the filter frequency response curves. The crossover values for the models, which assume no loss, occur close to 3 dB. For the actual filters, which are lossy, the crossover points occur elsewhere.

Table 3. RESONANT FREQUENCY: MODEL VERSUS EXPERIMENT

Filter #	f_0 [GHz]				Error %		
	Experiment	Model A	Model A1	Model B	Model A	Model A1	Model B
1	10.040	10.0468	10.048	N/A	0.07	0.08	N/A
2	10.012	10.054	10.057	N/A	0.42	0.45	N/A
3	9.9975	10.039	10.042	N/A	0.42	0.44	N/A
4	9.9175	9.937	N/A	9.924	0.20	N/A	0.07
5	9.9025	9.967	N/A	9.959	0.65	N/A	0.57
6	9.8725	9.947	N/A	9.944	0.76	N/A	0.72
7	9.6724	9.712	N/A	9.709	0.41	N/A	0.38
8	9.7300	9.758	N/A	9.752	0.29	N/A	0.23
9	9.7150	9.748	N/A	9.744	0.34	N/A	0.30
10	9.5525	9.620	N/A	9.607	0.71	N/A	0.57
11	9.645	9.655	N/A	9.646	0.10	N/A	0.01
12	9.6824	9.6736	N/A	9.668	0.09	N/A	0.15

The experimental and model results are compared in Table 4 on page 17. The agreement in this case is not nearly as good as for the resonant frequency. The error varies from 0.00 to 17.03%. This is expected since the bandwidth depends on the various losses in the filter as well as the magnitude of the scattering coefficients. The magnitude of the scattering coefficients determined by the spectral-domain programs assumes lossless dielectrics and conductors. This is a more realistic assumption for conductors than for dielectrics. The problem is increased because in the presence of a dielectric the electric field tends to concentrate in the dielectric.

E. APPEARANCE OF FILTER FREQUENCY RESPONSE CURVE

The final criteria used to judge the success of the models is how closely the curves generated by the models resemble those obtained experimentally. To make the best possible comparison the frequency response was plotted by either Model A1 or Model B using the same axes as were used for the experimental plots. The resulting graphs have approximately the same size. There will be a difference in the plots due to the loss in the actual filters. The general form of the frequency response should however be similar between the two. A review of the frequency response curves in Appendix E shows that

Table 4. CROSSOVER BANDWIDTH: MODEL VERSUS EXPERIMENT

Filter #	Δf [MHz]				Error %		
	Experiment	Model A	Model A1	Model B	Model A	Model A1	Model B
1	350.0	329.5	307	N/A	5.86	12.29	N/A
2	218.0	209	196.6	N/A	4.13	9.82	N/A
3	142.5	133	129.5	N/A	6.67	9.12	N/A
4	462.5	507.5	N/A	526	9.73	N/A	13.73
5	295.0	302	N/A	295	2.37	N/A	0.00
6	204.9	181	N/A	170	11.66	N/A	17.03
7	425.0	398	N/A	439	6.35	N/A	3.29
8	235.0	199	N/A	213	15.32	N/A	9.36
9	132.5	111	N/A	113	16.23	N/A	14.72
10	290.0	247	N/A	277	14.83	N/A	4.48
11	147.6	135	N/A	143	8.54	N/A	3.12
12	70.0	77.6	N/A	77	10.86	N/A	10.00

the model curves have the same general form. For ease of comparison the experimental and modelled curve are shown on the same page. Both have been reduced about 50% to fit on the page.

F. ERROR ANALYSIS

The model precision is arbitrary. The curves were generated with a general precision of 0.1 GHz, with 0.01 GHz used between the crossover points and slightly beyond and 0.001 used in the vicinity of the crossover points and the resonant frequency. The results therefore give the model approximation with an accuracy of ± 1.0 MHz. The model response depends on the measurements made of the actual finline. The filter measurements are accurate to ± 0.01 mm which is the same as ± 0.4 mils. For some of the smaller w/b , the edges of the inductive strips were not straight, so best judgement was used to select the strip edge. This may have contributed some more error. The accuracy of the resonant frequency calculations indicates that generally the strip lengths were correctly measured, since the phase is most sensitive to errors in distance, particularly for the resonator length.

The experimental results have several sources of error due to measurement apparatus. The sources of experimental error are:

1. Absolute sweep generator error - ± 25 MHz,
2. Linear sweep generator error - ± 4 MHz and
3. Digitization error - ± 2.5 MHz.

1. Absolute Sweep Generator Error

The largest source of error is the absolute sweep generator error. The specified maximum for the absolute sweep generator error is ± 25 Mhz while the typical value is stated to be ± 8 MHz. Only the maximum value is guaranteed not to be exceeded. Using the maximum error and the digitization step of 2.5 MHz, the maximum possible error for the scalar analyzer is 27.5 MHz. Taking this as a percentage of the nominal resonant frequency of 10 GHz gives an error of 0.275%. Even when this error is subtracted from the errors in Table 3 on page 16 there still exists a small discrepancy for about half the resonant frequencies.

2. Linear Sweep Generator Error

The linear frequency error applies for the case where two frequency measurements are being compared. In this case the total error is the sum of the two linear frequency errors plus the two digitization errors. The total resulting error is ± 13 MHz, which is greater than the difference between model and experiment for many of the filter results given in Table 4 on page 17. The percentage errors appear so great because of the small values of the bandwidth.

G. DIELECTRIC LOSSES

The experiments were conducted with an abrupt dielectric transition between the air filled waveguide and the inhomogeneous finline. This was done because of the difficulty of accurately fabricating a dielectric taper. This transition will have contributed some loss to the structure as will the dielectric itself.

To determine the losses due to the dielectric the fixture containing only dielectric was inserted into the scalar analyzer and the reflection and transmission coefficients measured. The insertion and return loss are shown in Figure 5 on page 19. The return loss averages about 20 dB while the insertion loss is visibly below the reference 0 dB line.

Using the impedances of the air filled and finline filled waveguide sections, the expected reflection coefficient at the transition was calculated using

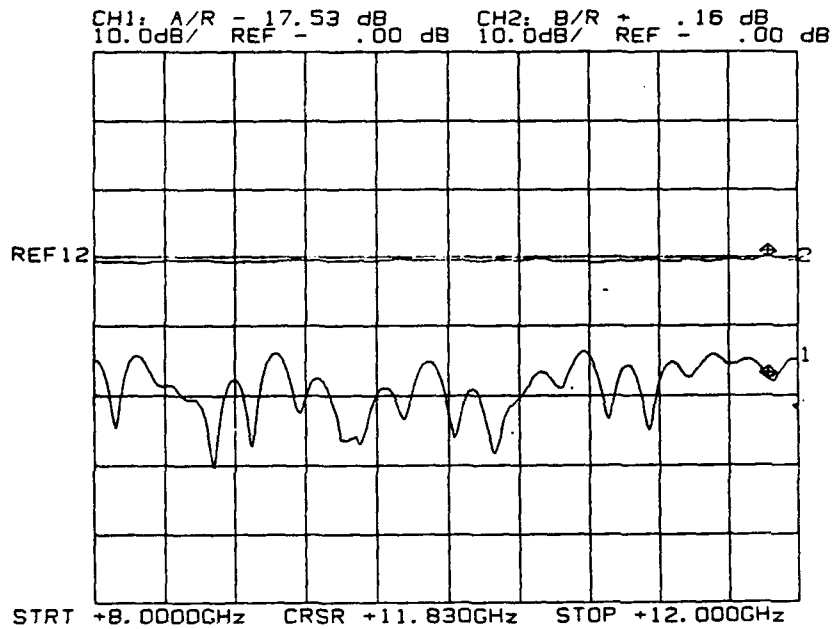

Figure 5. Dielectric Reflection and Transmission Coefficients

$$\Gamma = \frac{Z_{1V} - Z_{0V}}{Z_{1V} + Z_{0V}} \quad (20)$$

where $Z_{0V} = 444.1$, the impedance of the air filled waveguide, is found using eqn 6 and $Z_{1V} = 465.5$, the impedance of the section of waveguide containing the finline, is found using the same equation but with the appropriate equivalent dimensions. The reflection coefficient is $\Gamma = 0.0235$ which corresponds to a return loss of 32.6 dB. The actual reflection coefficient is somewhat higher than the calculated one but still much too small to account for the insertion loss.

The transmission coefficient is shown at a larger scale in Figure 6 on page 20. The transmission coefficient varies from a low of about -0.9 dB to a high of 0.16 dB. The high value of the transmission coefficient of 0.16 dB is probably due to an error in the measurement system. The average insertion loss is about 0.4 dB. From the size of the return loss it appears that most of this loss must be due to losses either in the dielectric or in the waveguide walls.

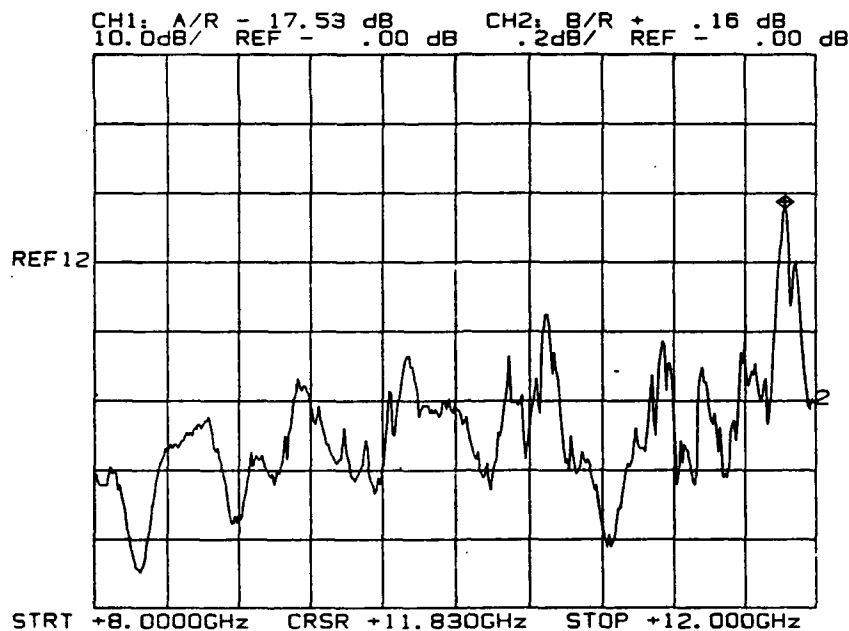

Figure 6. Dielectric Transmission Coefficient

Clearly part of the loss in the filters is due to either the dielectric or the waveguide walls. While the dielectric is the most likely culprit, the waveguide walls may be inducing losses due to irregularities introduced during machining. When the waveguide interior is observed at an angle in the light it appears dirty because of the tooling marks. When viewed directly it appears to be clean.

The presence of this loss may be affecting the crossover bandpass measurements. It has also been suggested that the discrepancy in the bandwidth measurements might be the result of mutual coupling between the two strips. The resonator lengths are less than half the wavelength. The model assumes that the two strips are independent and that there is no coupling between them. This mutual coupling could be giving an reflection coefficient which is different from that obtained assuming uncoupled strips.

It has also been suggested that loss in the dielectric around the strips may be perturbing the reflection scattering coefficient of the strips. Since the filter Q and therefore the filter bandwidth are primarily determined by the magnitude of the strip reflection coefficient, the presence of loss in the dielectric may be causing the perturbations in the filter bandwidth.

V. CONCLUSIONS AND RECOMMENDATIONS

A. CONCLUSIONS

This thesis has shown experimentally that the models and spectral-domain programs developed for inhomogeneous finline and inductive strips for inhomogeneous finline give resonant frequencies for simple bandpass filters which have less than one percent error when compared to actual experimental results. Since the CAD models were developed to have one or two percent error with respect to the spectral-domain data, errors of less than one percent in the resonant frequency indicate that the angles of the scattering coefficients have the required accuracy.

The crossover bandwidth results have an average error of nine percent. Therefore the magnitudes of the scattering coefficients cannot be considered to be accurate without further study.

B. RECOMMENDATIONS FOR FURTHER STUDY

The magnitude of the scattering coefficients of inductive strips in inhomogeneous finline needs to be measured accurately to determine if the discrepancy in the bandwidth measurements is due to loss in general, or if the magnitudes of the scattering coefficients generated by the spectral-domain program *STRIP* are inaccurate due to the assumption of a lossless dielectric.

APPENDIX A. MODEL A TOUCHSTONE CIRCUIT FILE

```

! FILE: FILMODA.CKT
! USER: J. P. MUIR
! DATE: 29 JULY 1991
! CIRCUIT: FILTER WITH 2 STRIPS AND 1 RESONATOR IN FINLINE WITH
!           ARBITRARY W/B AND DIELECTRIC THICKNESS
!
! COMMENT: Model a one resonator filter. Use the scattering
!           coefficients generated by spectral-domain program
!           STRIP for the inductive strips. Use dielectric
!           loaded waveguide for the resonator and the finline
!           before and after the filter with the equivalent
!           waveguide dimensions and the equivalent relative
!           dielectric constant found using the formulae in
!           Janeen Grohsmeyer's report dated November 1990.

```

DIM

```

FREQ GHZ
RES OH
IND NH
CAP PF
LNG MIL
TIME PS
COND /OH
ANG DEG

```

VAR

```

IN2MIL = 1000
M2CM = 100
IN2CM = 2.54
M2MIL = 39370
CO = 0.3           ! SPEED OF LIGHT [M/S]/1E9
A = 900           ! FINLINE SHIELD WIDTH [MILS]
B = 400           ! FINLINE SHIELD HEIGHT
Wovb = 0.20       ! FIN SEPARATION TO SHIELD HEIGHT
D = 31            ! FIN DIELECTRIC THICKNESS
ER=2.22          ! FIN DIELECTRIC PERMITTIVITY
L = 4651.5        ! TOTAL LENGTH OF WAVEGUIDE
R = 492           ! LENGTH OF RESONATOR 1
pi = 3.14159

```

EQN

```

DovA = D/A
DovA2 = DovA*DovA
BovA = B/A

C1=-4.9723*(BovA)**2 + 4.7413*BovA - 0.7651
Aeq=A*( 2 - SQRT(1 - (BovA + 0.45)*(1 - Wovb)**2 ) + C1*(1 - Wovb)**26 )

C2A = -115.79*DovA2 + 27.87*DovA - 0.4933
C2 = C2A*BovA + 87.52*DovA2 - 22.49*DovA - 0.1932
C3 = 0.29 + 0.0773*EXP(1 - 40*DovA)

```

$C4A = 20.1154 * DovA2 - 3.5729 * DovA - 0.0611$
 $C4 = C4A * BovA - 26.1788 * DovA2 + 5.537 * DovA + 1.0376$
 $C5 = -13.5217 * DovA2 + 2.4017 * DovA + 0.0411$
 $Beq1 = 0.025 * (1 - (0.925 - Wovb) * (0.925 - Wovb))^{**16}$
 $Beq2 = C4 + C5 * (1 - (BovA - Wovb) * (BovA - Wovb))^{**4}$
 $Beq3 = B * (C2 * (1 - Wovb^{**2} * B * C3 / A)) + Beq2 - Beq1$

$C6A = -76.251 * DovA2 + 17.23 * DovA - 0.1578$
 $C6 = C6A * BovA + 111.2 * DovA2 - 20.84 * DovA + 0.1703$
 $C7A = 64.82 * DovA2 - 14.77 * DovA - 0.3029$
 $C7 = C7A * BovA - 107.1 * DovA2 + 22.85 * DovA - 0.2936$
 $C8A = 9.696 * DovA2 - 1.449 * DovA - 0.1431$
 $C8 = C8A * BovA - 12.13 * DovA2 + 1.39 * DovA + 0.1195$
 $M = C6 * Wovb^{**2} + C7 * Wovb + C8$
 $FC = C0 * M2MIL / (2 * Aeq)$
 $Beq = B * M * (FREQ / FC - 1.56) + Beq3$

$C9 = -20.16 * DovA2 + 6.42 * DovA + 0.6494$
 $KEA = C9 * (1 - Wovb^{**2} * (1 - EXP(-10 * DovA))) + Wovb$
 $KE = KEA + 2.604 * DovA + (1 - DovA)^{**6} * (1 - Wovb)$

! FIND VOLTAGE POWER IMPEDANCE OF THE WAVEGUIDE
! WITH W/B=1.0 AND KE
 $LAMBO = C0 * M2MIL / FREQ$
 $GFAC = (KE - (LAMBO / (2 * Aeq))^{**2})^{**2} * (1/2)$
 $ZOV = (120 * pi^{**2} * Beq / Aeq) / GFAC$
 $X1 = (50 / ZOV)^{**2} * (1/2)$

CKT

! TRANSFORMER TO MATCH STRIP SCATTERING DATA AT 50 OHMS TO
! WAVEGUIDE VOLTAGE POWER IMPEDANCE ZOV
XFER 1 2 0 0 N^X1
DEF2P 1 2 TRANS

! MODEL FOR LENGTH OF FINLINE BETWEEN STRIPS
RWG 1 2 A^Aeq B^Beq L^R ER^KE RHO=0
DEF2P 1 2 RES01

! MODEL FOR LENGTH OF FINLINE OUTSIDE STRIPS
RWG 1 2 A^Aeq B^Beq L^L ER^KE RHO=0
DEF2P 1 2 FIN

! STRIP1 MODEL
S2PA 1 2 0 W020T102
DEF2P 1 2 STRIP1

! STRIP2 MODEL
S2PB 1 2 0 W020T103
DEF2P 1 2 STRIP2

! FILTER MODEL
STRIP1 1 2
TRANS 2 3
RES01 3 4
TRANS 5 4
STRIP2 5 6

DEF2P 1 6 FIL

FIN 1 2
TRANS 3 2
FIL 3 4
TRANS 4 5
FIN 5 6
DEF2P 1 6

FINFIL

RWGT 1 A^Aeq B^Beq ER^KE RHO=1
DEF1P 1 WEDGE

TERM

FINFIL WEDGE WEDGE

OUT

FINFIL DB[S11] GR1
FINFIL DB[S21] GR1
STRIP1 DB[S11] GR2
STRIP1 DB[S21] GR2
STRIP2 DB[S11] GR2
STRIP2 DB[S21] GR2
STRIP1 ANG[S11] GR3
STRIP1 ANG[S21] GR3
STRIP2 ANG[S11] GR3
STRIP2 ANG[S21] GR3

FREQ

SWEEP 8.0 12.0 0.1
SWEEP 9.41 9.99 0.01
SWEEP 9.521 9.529 0.001
SWEEP 9.705 9.715 0.001
SWEEP 9.921 9.929 0.001
! SWEEP 10.045 10.047 0.0001

GRID !SET UP GRID SCALING

RANGE 8 12 .4
GR1 -25 15 5

APPENDIX B. MODEL B TOUCHSTONE CIRCUIT FILE

```

! FILE: FILMOB5. CKT
! USER: J. P. MUIR
! DATE: 22 JULY 1991
! CIRCUIT: FILTER WITH 2 STRIPS AND 1 RESONATOR IN FINLINE
!           WITH DIELECTRIC AND FINLINE TAPER FOR W/B=0.5
!
! COMMENT: Model a one resonator filter. Use the scattering
!           coefficients generated by spectral-domain program
!           STRIP for the inductive strips. Use dielectric
!           loaded waveguide for the resonator and the finline
!           before and after the filter with the equivalent
!           waveguide dimensions and the equivalent relative
!           dielectric constant found using the formulae in
!           Janeen Grohsmeyer's report dated November 1990.
!           Simulate the finline taper with 20 equal steps.
!           The equivalent dimensions and relative dielectric
!           constant are computed externally and inserted
!           into the circuit file.

```

DIM

```

FREQ GHZ
RES OH
IND NH
CAP PF
LNG MIL
TIME PS
COND /OH
ANG DEG

```

VAR

```

IN2MIL = 1000
M2CM = 100
IN2CM = 2.54
M2MIL = 39370
CO = 0.3           ! SPEED OF LIGHT [M/S]/1E9
A = 900           ! FINLINE SHIELD WIDTH [MILS]
B = 400           ! FINLINE SHIELD HEIGHT
Wovb = 0.50      ! FIN SEPARATION TO SHIELD HEIGHT
D = 31           ! FIN DIELECTRIC THICKNESS
ER=2.22          ! FIN DIELECTRIC PERMITTIVITY
LF = 2000        ! LENGTH OF FINLINE BETWEEN TAPERS
T1 = 151         ! LENGTH OF INDUCTIVE STRIP 1
R = 492          ! LENGTH OF RESONATOR 1
T2 = 149         ! LENGTH OF INDUCTIVE STRIP 2
pi = 3.14159

```

EQN

```

DovA = D/A
DovA2 = DovA*DovA
BovA = B/A
L=(LF-T1-R-T2)/2

```

C1=-4.9723*(BovA)**2 + 4.7413*BovA - 0.7651
 Aeq=A*(2 - SQRT(1 - (BovA + 0.45)*(1 - Wovb)**2) + C1*(1 - Wovb)**26)

C2A = -115.79*DovA2 + 27.87*DovA - 0.4933
 C2 = C2A*BovA + 87.52*DovA2 - 22.49*DovA - 0.1932
 C3 = 0.29 + 0.0773*EXP(1 - 40*DovA)
 C4A = 20.1154*DovA2 - 3.5729*DovA - 0.0611
 C4 = C4A*BovA - 26.1788*DovA2 + 5.537*DovA + 1.0376
 C5 = -13.5217*DovA2 + 2.4017*DovA + 0.0411
 Beq1 = 0.025*(1 - (0.925 - Wovb)*(0.925 - Wovb))**16
 Beq2 = C4 + C5*(1 - (BovA - Wovb)*(BovA - Wovb))**4
 Beq3 = B*(C2*(1 - Wovb)**(2*B*C3/A)) + Beq2 - Beq1)

C6A = -76.251*DovA2 + 17.23*DovA - 0.1578
 C6 = C6A*BovA + 111.2*DovA2 - 20.84*DovA + 0.1703
 C7A = 64.82*DovA2 - 14.77*DovA - 0.3029
 C7 = C7A*BovA - 107.1*DovA2 + 22.85*DovA - 0.2936
 C8A = 9.696*DovA2 - 1.449*DovA - 0.1431
 C8 = C8A*BovA - 12.13*DovA2 + 1.39*DovA + 0.1195
 M = C6*Wovb**2 + C7*Wovb + C8
 FC = C0*M2MIL/(2*Aeq)
 Beq = B*M*(FREQ/FC-1.56) + Beq3

C9=-20.16*DovA2 + 6.42*DovA + 0.6494
 KEA=C9*(1-Wovb**(1-EXP(-10*DovA))) + Wovb
 KE=KEA + 2.604*DovA + (1-DovA)**6*(1-Wovb)

! FIND VOLTAGE POWER IMPEDANCE OF THE WAVEGUIDE
 ! WITH W/B=1.0 AND KE
 LAMBO=C0*M2MIL/FREQ
 GFAC=(KE-(LAMBO/(2*Aeq))**2)**(1/2)
 ZOV=(120*pi*2*Beq/Aeq)/GFAC
 X1=(50/ZOV)**(1/2)

CKT

! TRANSFORMER TO MATCH STRIP SCATTERING DATA AT 50 OHMS TO
 ! WAVEGUIDE VOLTAGE POWER IMPEDANCE ZOV
 XFER 1 2 0 0 N^X1
 DEF2P 1 2 TRANS

! MODEL FOR LENGTH OF FINLINE BETWEEN STRIPS
 RWG 1 2 A^Aeq B^Beq L^R ER^KE RHO=0
 DEF2P 1 2 RES01

! MODEL FOR LENGTH OF FINLINE OUTSIDE STRIPS
 RWG 1 2 A^Aeq B^Beq L^L ER^KE RHO=0
 DEF2P 1 2 FIN

! MODEL FOR TAPER PLUS FINLINE
 RWG 1 2 A=900.0 B=453.3 L=2000.0 ER=1.0897 RHO=0 !W/B=1.0000
 RWG 2 3 A=900.3 B=452.0 L=100.0 ER=1.0912 RHO=0 !W/B=0.9750
 RWG 3 4 A=901.0 B=451.0 L=100.0 ER=1.0928 RHO=0 !W/B=0.9500
 RWG 4 5 A=902.3 B=450.2 L=100.0 ER=1.0945 RHO=0 !W/B=0.9250
 RWG 5 6 A=904.0 B=449.6 L=100.0 ER=1.0963 RHO=0 !W/B=0.9000
 RWG 6 7 A=906.3 B=449.3 L=100.0 ER=1.0983 RHO=0 !W/B=0.8750

RWG	7	8	A=909.1	B=449.1	L=100.0	ER=1.1004	RHO=0	!W/B=0.8500	
RWG	8	9	A=912.4	B=449.0	L=100.0	ER=1.1027	RHO=0	!W/B=0.8250	
RWG	9	10	A=916.2	B=449.1	L=100.0	ER=1.1051	RHO=0	!W/B=0.8000	
RWG	10	11	A=920.6	B=449.2	L=100.0	ER=1.1076	RHO=0	!W/B=0.7750	
RWG	11	12	A=925.5	B=449.2	L=100.0	ER=1.1104	RHO=0	!W/B=0.7500	
RWG	12	13	A=931.0	B=449.2	L=100.0	ER=1.1133	RHO=0	!W/B=0.7250	
RWG	13	14	A=937.0	B=449.1	L=100.0	ER=1.1164	RHO=0	!W/B=0.7000	
RWG	14	15	A=943.6	B=448.8	L=100.0	ER=1.1197	RHO=0	!W/B=0.6750	
RWG	15	16	A=950.7	B=448.3	L=100.0	ER=1.1232	RHO=0	!W/B=0.6500	
RWG	16	17	A=958.5	B=447.5	L=100.0	ER=1.1269	RHO=0	!W/B=0.6250	
RWG	17	18	A=966.9	B=446.5	L=100.0	ER=1.1309	RHO=0	!W/B=0.6000	
RWG	18	19	A=975.9	B=445.2	L=100.0	ER=1.1352	RHO=0	!W/B=0.5750	
RWG	19	20	A=985.6	B=443.6	L=100.0	ER=1.1397	RHO=0	!W/B=0.5500	
RWG	20	21	A=995.9	B=441.7	L=100.0	ER=1.1445	RHO=0	!W/B=0.5250	
RWG	21	22	A=1007.0	B=439.4	L=100.0	ER=1.1497	RHO=0	!W/B=0.5000	
DEF2P	1	22	TPR						

```
! STRIP1 MODEL
S2PA 1 2 0 W050T151
DEF2P 1 2 STRIP1
```

```
! STRIP2 MODEL
S2PB 1 2 0 W050T149
DEF2P 1 2 STRIP2
```

```
! FILTER MODEL
STRIP1 1 2
TRANS 2 3
RES01 3 4
TRANS 5 4
STRIP2 5 6
DEF2P 1 6 FIL
```

```
! TOTAL MODEL
TPR 1 2
FIN 2 3
TRANS 4 3
FIL 4 5
TRANS 5 6
FIN 6 7
TPR 8 7
DEF2P 1 8 FINFIL
```

```
RWGT 1 A^A B^B ER=1 RHO=0
DEF1P 1 WEDGE
```

```
TERM
FINFIL WEDGE WEDGE
```

```
OUT
FINFIL DB[S11] GR1
FINFIL DB[S21] GR1
STRIP1 DB[S11] GR2
STRIP1 DB[S21] GR2
STRIP2 DB[S11] GR2
STRIP2 DB[S21] GR2
```

STRIP1 ANG[S11] GR3
STRIP1 ANG[S21] GR3
STRIP2 ANG[S11] GR3
STRIP2 ANG[S21] GR3

FREQ

SWEEP 8.0 12.0 0.1
SWEEP 9.75 10.19 0.01
SWEEP 9.821 9.829 0.001
SWEEP 9.955 9.965 0.001
SWEEP 10.121 10.129 0.001
! SWEEP 10.045 10.047 0.0001

GRID ! SET UP GRID SCALING

RANGE 8 12 .4
GR1 -25 15 5

APPENDIX C. FINLINE TAPER VALUES

A. W/B=0.1

RWG	1	2	A=900.0	B=453.3	L=2000.0	ER=1.0897	RHO=0	!W/B=1.0000	Fc=6.562
RWG	2	3	A=900.8	B=451.2	L=100.0	ER=1.0924	RHO=0	!W/B=0.9550	Fc=6.556
RWG	3	4	A=903.3	B=449.9	L=100.0	ER=1.0956	RHO=0	!W/B=0.9100	Fc=6.538
RWG	4	5	A=907.4	B=449.2	L=100.0	ER=1.0991	RHO=0	!W/B=0.8650	Fc=6.508
RWG	5	6	A=913.1	B=449.0	L=100.0	ER=1.1031	RHO=0	!W/B=0.8200	Fc=6.467
RWG	6	7	A=920.6	B=449.2	L=100.0	ER=1.1076	RHO=0	!W/B=0.7750	Fc=6.415
RWG	7	8	A=929.8	B=449.2	L=100.0	ER=1.1127	RHO=0	!W/B=0.7300	Fc=6.351
RWG	8	9	A=940.9	B=448.9	L=100.0	ER=1.1183	RHO=0	!W/B=0.6850	Fc=6.277
RWG	9	10	A=953.8	B=448.0	L=100.0	ER=1.1247	RHO=0	!W/B=0.6400	Fc=6.192
RWG	10	11	A=968.6	B=446.2	L=100.0	ER=1.1317	RHO=0	!W/B=0.5950	Fc=6.097
RWG	11	12	A=985.6	B=443.6	L=100.0	ER=1.1397	RHO=0	!W/B=0.5500	Fc=5.992
RWG	12	13	A=1004.7	B=439.9	L=100.0	ER=1.1486	RHO=0	!W/B=0.5050	Fc=5.878
RWG	13	14	A=1026.2	B=435.3	L=100.0	ER=1.1587	RHO=0	!W/B=0.4600	Fc=5.755
RWG	14	15	A=1050.3	B=429.6	L=100.0	ER=1.1701	RHO=0	!W/B=0.4150	Fc=5.623
RWG	15	16	A=1077.2	B=422.9	L=100.0	ER=1.1831	RHO=0	!W/B=0.3700	Fc=5.482
RWG	16	17	A=1107.3	B=415.1	L=100.0	ER=1.1981	RHO=0	!W/B=0.3250	Fc=5.333
RWG	17	18	A=1141.0	B=406.1	L=100.0	ER=1.2155	RHO=0	!W/B=0.2800	Fc=5.176
RWG	18	19	A=1179.0	B=395.7	L=100.0	ER=1.2360	RHO=0	!W/B=0.2350	Fc=5.009
RWG	19	20	A=1222.9	B=383.7	L=100.0	ER=1.2609	RHO=0	!W/B=0.1900	Fc=4.829
RWG	20	21	A=1276.0	B=369.7	L=100.0	ER=1.2918	RHO=0	!W/B=0.1450	Fc=4.628
RWG	21	22	A=1348.5	B=352.9	L=100.0	ER=1.3328	RHO=0	!W/B=0.1000	Fc=4.379
DEF2P	1	22	TPR						

B. W/B=0.2

RWG	1	2	A=900.0	B=453.3	L=2000.0	ER=1.0897	RHO=0	!W/B=1.0000	Fc=6.562
RWG	2	3	A=900.6	B=451.4	L=100.0	ER=1.0921	RHO=0	!W/B=0.9600	Fc=6.557
RWG	3	4	A=902.6	B=450.1	L=100.0	ER=1.0948	RHO=0	!W/B=0.9200	Fc=6.543
RWG	4	5	A=905.8	B=449.3	L=100.0	ER=1.0979	RHO=0	!W/B=0.8800	Fc=6.520
RWG	5	6	A=910.4	B=449.1	L=100.0	ER=1.1013	RHO=0	!W/B=0.8400	Fc=6.487
RWG	6	7	A=916.2	B=449.1	L=100.0	ER=1.1051	RHO=0	!W/B=0.8000	Fc=6.445
RWG	7	8	A=923.5	B=449.2	L=100.0	ER=1.1092	RHO=0	!W/B=0.7600	Fc=6.395
RWG	8	9	A=932.1	B=449.2	L=100.0	ER=1.1139	RHO=0	!W/B=0.7200	Fc=6.335
RWG	9	10	A=942.2	B=448.9	L=100.0	ER=1.1190	RHO=0	!W/B=0.6800	Fc=6.268
RWG	10	11	A=953.8	B=448.0	L=100.0	ER=1.1247	RHO=0	!W/B=0.6400	Fc=6.192
RWG	11	12	A=966.9	B=446.5	L=100.0	ER=1.1309	RHO=0	!W/B=0.6000	Fc=6.108
RWG	12	13	A=981.6	B=444.2	L=100.0	ER=1.1378	RHO=0	!W/B=0.5600	Fc=6.016
RWG	13	14	A=998.1	B=441.2	L=100.0	ER=1.1455	RHO=0	!W/B=0.5200	Fc=5.917
RWG	14	15	A=1016.4	B=437.5	L=100.0	ER=1.1541	RHO=0	!W/B=0.4800	Fc=5.810
RWG	15	16	A=1036.6	B=432.9	L=100.0	ER=1.1636	RHO=0	!W/B=0.4400	Fc=5.697
RWG	16	17	A=1058.9	B=427.5	L=100.0	ER=1.1743	RHO=0	!W/B=0.4000	Fc=5.577
RWG	17	18	A=1083.6	B=421.2	L=100.0	ER=1.1863	RHO=0	!W/B=0.3600	Fc=5.450
RWG	18	19	A=1110.8	B=414.1	L=100.0	ER=1.1999	RHO=0	!W/B=0.3200	Fc=5.316
RWG	19	20	A=1141.0	B=406.1	L=100.0	ER=1.2155	RHO=0	!W/B=0.2800	Fc=5.176
RWG	20	21	A=1174.5	B=396.9	L=100.0	ER=1.2336	RHO=0	!W/B=0.2400	Fc=5.028
RWG	21	22	A=1212.5	B=386.5	L=100.0	ER=1.2549	RHO=0	!W/B=0.2000	Fc=4.871
DEF2P	1	22	TPR						

C. W/B=0.5

RWG	1	2	A=900.0	B=453.3	L=2000.0	ER=1.0897	RHO=0	!W/B=1.0000	Fc=6.562
RWG	2	3	A=900.3	B=452.0	L=100.0	ER=1.0912	RHO=0	!W/B=0.9750	Fc=6.560
RWG	3	4	A=901.0	B=451.0	L=100.0	ER=1.0928	RHO=0	!W/B=0.9500	Fc=6.554
RWG	4	5	A=902.3	B=450.2	L=100.0	ER=1.0945	RHO=0	!W/B=0.9250	Fc=6.545
RWG	5	6	A=904.0	B=449.6	L=100.0	ER=1.0963	RHO=0	!W/B=0.9000	Fc=6.532
RWG	6	7	A=906.3	B=449.3	L=100.0	ER=1.0983	RHO=0	!W/B=0.8750	Fc=6.516
RWG	7	8	A=909.1	B=449.1	L=100.0	ER=1.1004	RHO=0	!W/B=0.8500	Fc=6.496
RWG	8	9	A=912.4	B=449.0	L=100.0	ER=1.1027	RHO=0	!W/B=0.8250	Fc=6.472
RWG	9	10	A=916.2	B=449.1	L=100.0	ER=1.1051	RHO=0	!W/B=0.8000	Fc=6.445
RWG	10	11	A=920.6	B=449.2	L=100.0	ER=1.1076	RHO=0	!W/B=0.7750	Fc=6.415
RWG	11	12	A=925.5	B=449.2	L=100.0	ER=1.1104	RHO=0	!W/B=0.7500	Fc=6.381
RWG	12	13	A=931.0	B=449.2	L=100.0	ER=1.1133	RHO=0	!W/B=0.7250	Fc=6.343
RWG	13	14	A=937.0	B=449.1	L=100.0	ER=1.1164	RHO=0	!W/B=0.7000	Fc=6.303
RWG	14	15	A=943.6	B=448.8	L=100.0	ER=1.1197	RHO=0	!W/B=0.6750	Fc=6.259
RWG	15	16	A=950.7	B=448.3	L=100.0	ER=1.1232	RHO=0	!W/B=0.6500	Fc=6.212
RWG	16	17	A=958.5	B=447.5	L=100.0	ER=1.1269	RHO=0	!W/B=0.6250	Fc=6.161
RWG	17	18	A=966.9	B=446.5	L=100.0	ER=1.1309	RHO=0	!W/B=0.6000	Fc=6.108
RWG	18	19	A=975.9	B=445.2	L=100.0	ER=1.1352	RHO=0	!W/B=0.5750	Fc=6.051
RWG	19	20	A=985.6	B=443.6	L=100.0	ER=1.1397	RHO=0	!W/B=0.5500	Fc=5.992
RWG	20	21	A=995.9	B=441.7	L=100.0	ER=1.1445	RHO=0	!W/B=0.5250	Fc=5.930
RWG	21	22	A=1007.0	B=439.4	L=100.0	ER=1.1497	RHO=0	!W/B=0.5000	Fc=5.865
DEF2P	1	22	TPR						

APPENDIX D. TOUCHSTONE DATA FILES

A. W/B=0.1

1. Strip Length = 42.6 Mils

! DIELECTRIC THICKNESS = 31 MILS
! W/B=0.1
! STRIP LENGTH = 42.6 MILS
! DATA FROM STRIP PROGRAM
! FILE NAME: W010T042.s2p
! USER: John Muir
! DATE: 15 July 1991

! S-PARAMETER DATA

GHZ S MA R 50

! SCATTERING PARAMETERS:

! FREQ /S11/ <S11 /S21/ <S21 /S12/ <S12 /S22/ <S22

7.0000	0.9786	162.4922	0.2056	72.4922	0.2056	72.4922	0.9786	162.4922
8.0000	0.9693	158.6426	0.2460	68.6426	0.2460	68.6426	0.9693	158.6426
9.0000	0.9588	155.4258	0.2841	65.4258	0.2841	65.4258	0.9588	155.4258
10.0000	0.9459	151.7344	0.3244	61.7344	0.3244	61.7344	0.9459	151.7344
11.0000	0.9303	148.9395	0.3668	58.9395	0.3668	58.9395	0.9303	148.9395
12.0000	0.9121	144.2461	0.4100	54.2461	0.4100	54.2461	0.9121	144.2461
13.0000	0.8876	141.0293	0.4605	51.0293	0.4605	51.0293	0.8876	141.0293

2. Strip Length = 46.5 mils

! DIELECTRIC THICKNESS = 31 MILS
! W/B=0.1
! STRIP LENGTH = 46.5 MILS
! DATA FROM STRIP PROGRAM
! FILE NAME: W010T046.s2p
! USER: John Muir
! DATE: 15 July 1991

! S-PARAMETER DATA

GHZ S MA R 50

! SCATTERING PARAMETERS:

! FREQ /S11/ <S11 /S21/ <S21 /S12/ <S12 /S22/ <S22

7.0000	0.9803	162.6504	0.1975	72.6504	0.1975	72.6504	0.9803	162.6504
8.0000	0.9717	158.8008	0.2361	68.8008	0.2361	68.8008	0.9717	158.8008
9.0000	0.9616	155.5840	0.2744	65.5840	0.2744	65.5840	0.9616	155.5840
10.0000	0.9494	151.8398	0.3140	61.8398	0.3140	61.8398	0.9494	151.8398
11.0000	0.9346	148.9922	0.3556	58.9922	0.3556	58.9922	0.9346	148.9922
12.0000	0.9169	144.2988	0.3991	54.2988	0.3991	54.2988	0.9169	144.2988
13.0000	0.8927	140.9238	0.4507	50.9238	0.4507	50.9238	0.8927	140.9238

3. Strip Length = 82.1 mils

! DIELECTRIC THICKNESS = 31 MILS
! W/B=0.1
! STRIP LENGTH = 82.1 MILS
! DATA FROM STRIP PROGRAM
! FILE NAME: W010T082.s2p
! USER: John Muir
! DATE: 15 July 1991

! S-PARAMETER DATA

GHZ S MA R 50

! SCATTERING PARAMETERS:

! FREQ /S11/ <S11 /S21/ <S21 /S12/ <S12 /S22/ <S22

7.0000	0.9896	163.1250	0.1440	73.1250	0.1440	73.1250	0.9896	163.1250
8.0000	0.9846	159.3281	0.1749	69.3281	0.1749	69.3281	0.9846	159.3281
9.0000	0.9786	156.0586	0.2056	66.0586	0.2056	66.0586	0.9786	156.0586
10.0000	0.9706	152.2090	0.2406	62.2090	0.2406	62.2090	0.9706	152.2090
11.0000	0.9598	149.2031	0.2806	59.2031	0.2806	59.2031	0.9598	149.2031
12.0000	0.9450	143.8770	0.3271	53.8770	0.3271	53.8770	0.9450	143.8770
13.0000	0.9213	139.6582	0.3889	49.6582	0.3889	49.6582	0.9213	139.6582

4. Strip Length = 83.9 mils

! DIELECTRIC THICKNESS = 31 MILS
! W/B=0.1
! STRIP LENGTH = 83.9 MILS
! DATA FROM STRIP PROGRAM
! FILE NAME: W010T083.s2p
! USER: John Muir
! DATE: 15 July 1991

! S-PARAMETER DATA

GHZ S MA R 50

! SCATTERING PARAMETERS:

! FREQ /S11/ <S11 /S21/ <S21 /S12/ <S12 /S22/ <S22

7.0000	0.9900	163.1777	0.1413	73.1777	0.1413	73.1777	0.9900	163.1777
8.0000	0.9852	159.3281	0.1713	69.3281	0.1713	69.3281	0.9852	159.3281
9.0000	0.9790	156.0586	0.2038	66.0586	0.2038	66.0586	0.9790	156.0586
10.0000	0.9713	152.2617	0.2379	62.2617	0.2379	62.2617	0.9713	152.2617
11.0000	0.9606	149.1504	0.2779	59.1504	0.2779	59.1504	0.9606	149.1504
12.0000	0.9456	143.8770	0.3253	53.8770	0.3253	53.8770	0.9456	143.8770
13.0000	0.9220	139.5527	0.3872	49.5527	0.3872	49.5527	0.9220	139.5527
13.0000	0.9363	138.1816	0.3513	48.1816	0.3513	48.1816	0.9363	138.1816

5. Strip Length = 125 mils

! DIELECTRIC THICKNESS = 31 MILS
! W/B=0.1
! STRIP LENGTH = 125 MILS
! DATA FROM STRIP PROGRAM
! FILE NAME: W010T125.s2p
! USER: John Muir
! DATE: 15 July 1991

```

! S-PARAMETER DATA
# GHZ S MA R 50
! SCATTERING PARAMETERS:
! FREQ /S11/ <S11 /S21/ <S21 /S12/ <S12 /S22/ <S22

7.0000 0.9947 163.3887 0.1029 73.3887 0.1029 73.3887 0.9947 163.3887
8.0000 0.9918 159.5391 0.1276 69.5391 0.1276 69.5391 0.9918 159.5391
9.0000 0.9881 156.2168 0.1540 66.2168 0.1540 66.2168 0.9881 156.2168
10.0000 0.9828 152.3145 0.1848 62.3145 0.1848 62.3145 0.9828 152.3145
11.0000 0.9747 148.9922 0.2236 58.9922 0.2236 58.9922 0.9747 148.9922
12.0000 0.9619 143.2969 0.2735 53.2969 0.2735 53.2969 0.9619 143.2969
13.0000 0.9376 137.9707 0.3478 47.9707 0.3478 47.9707 0.9376 137.9707

```

6. Strip Length = 127 mils

```

! DIELECTRIC THICKNESS = 31 MILS
! W/B=0.1
! STRIP LENGTH = 127 MILS
! DATA FROM STRIP PROGRAM
! FILE NAME: W010T127.s2p
! USER: John Muir
! DATE: 15 July 1991

```

```

! S-PARAMETER DATA
# GHZ S MA R 50
! SCATTERING PARAMETERS:
! FREQ /S11/ <S11 /S21/ <S21 /S12/ <S12 /S22/ <S22

7.0000 0.9948 163.4414 0.1020 73.4414 0.1020 73.4414 0.9948 163.4414
8.0000 0.9921 159.5391 0.1258 69.5391 0.1258 69.5391 0.9921 159.5391
9.0000 0.9884 156.2168 0.1522 66.2168 0.1522 66.2168 0.9884 156.2168
10.0000 0.9831 152.3145 0.1830 62.3145 0.1830 62.3145 0.9831 152.3145
11.0000 0.9751 148.9922 0.2218 58.9922 0.2218 58.9922 0.9751 148.9922
12.0000 0.9621 143.2441 0.2726 53.2441 0.2726 53.2441 0.9621 143.2441
13.0000 0.9379 137.9180 0.3470 47.9180 0.3470 47.9180 0.9379 137.9180

```

B. W/B=0.2

1. Strip Length = 52.7 mils

```

! DIELECTRIC THICKNESS = 31 MILS
! W/B=0.2
! STRIP LENGTH = 52.7 MILS
! DATA FROM STRIP PROGRAM
! FILE NAME: W020T052.s2p
! USER: John Muir
! DATE: 15 July 1991

```

```

! S-PARAMETER DATA
# GHZ S MA R 50
! SCATTERING PARAMETERS:
! FREQ /S11/ <S11 /S21/ <S21 /S12/ <S12 /S22/ <S22

7.0000 0.9704 159.1172 0.2415 69.1172 0.2415 69.1172 0.9704 159.1172
8.0000 0.9551 154.2656 0.2964 64.2656 0.2964 64.2656 0.9551 154.2656
9.0000 0.9372 149.3086 0.3487 59.3086 0.3487 59.3086 0.9372 149.3086
10.0000 0.9169 145.1426 0.3991 55.1426 0.3991 55.1426 0.9169 145.1426

```

11.0000 0.8935 140.1855 0.4491 50.1855 0.4491 50.1855 0.8935 140.1855
12.0000 0.8646 135.9668 0.5025 45.9668 0.5025 45.9668 0.8646 135.9668
13.0000 0.8310 130.7461 0.5563 40.7461 0.5563 40.7461 0.8310 130.7461

2. Strip Length = 54.1 mils

! DIELECTRIC THICKNESS = 31 MILS
! W/B=0.2
! STRIP LENGTH = 54.1 MILS
! DATA FROM STRIP PROGRAM
! FILE NAME: W020T054.s2p
! USER: John Muir
! DATE: 15 July 1991

! S-PARAMETER DATA

GHZ S MA R 50

! SCATTERING PARAMETERS:

! FREQ /S11/ <S11 /S21/ <S21 /S12/ <S12 /S22/ <S22

7.0000 0.9711 159.1699 0.2388 69.1699 0.2388 69.1699 0.9711 159.1699
8.0000 0.9561 154.3711 0.2929 64.3711 0.2929 64.3711 0.9561 154.3711
9.0000 0.9388 149.3613 0.3444 59.3613 0.3444 59.3613 0.9388 149.3613
10.0000 0.9184 145.1426 0.3957 55.1426 0.3957 55.1426 0.9184 145.1426
11.0000 0.8951 140.1855 0.4458 50.1855 0.4458 50.1855 0.8951 140.1855
12.0000 0.8669 135.9141 0.4985 45.9141 0.4985 45.9141 0.8669 135.9141
13.0000 0.8330 130.6406 0.5533 40.6406 0.5533 40.6406 0.8330 130.6406

3. Strip Length = 102 mils

! DIELECTRIC THICKNESS = 31 MILS
! W/B=0.2
! STRIP LENGTH = 102 MILS
! DATA FROM STRIP PROGRAM
! FILE NAME: W020T102.s2p
! USER: John Muir
! DATE: 15 July 1991

! S-PARAMETER DATA

GHZ S MA R 50

! SCATTERING PARAMETERS:

! FREQ /S11/ <S11 /S21/ <S21 /S12/ <S12 /S22/ <S22

7.0000 0.9869 160.1191 0.1613 70.1191 0.1613 70.1191 0.9869 160.1191
8.0000 0.9792 155.2676 0.2029 65.2676 0.2029 65.2676 0.9792 155.2676
9.0000 0.9695 150.2578 0.2451 60.2578 0.2451 60.2578 0.9695 150.2578
10.0000 0.9572 145.8281 0.2894 55.8281 0.2894 55.8281 0.9572 145.8281
11.0000 0.9407 140.2910 0.3392 50.2910 0.3392 50.2910 0.9407 140.2910
12.0000 0.9166 135.0703 0.3999 45.0703 0.3999 45.0703 0.9166 135.0703
13.0000 0.8821 128.3203 0.4711 38.3203 0.4711 38.3203 0.8821 128.3203

4. Strip Length = 103 mils

! DIELECTRIC THICKNESS = 31 MILS
! W/B=0.2
! STRIP LENGTH = 103 MILS
! DATA FROM STRIP PROGRAM
! FILE NAME: W020T103.s2p

! USER: John Muir
! DATE: 15 July 1991

! S-PARAMETER DATA

GHZ S MA R 50

! SCATTERING PARAMETERS:

! FREQ /S11/ <S11 /S21/ <S21 /S12/ <S12 /S22/ <S22

7.0000	0.9869	160.1191	0.1613	70.1191	0.1613	70.1191	0.9869	160.1191
8.0000	0.9796	155.2676	0.2011	65.2676	0.2011	65.2676	0.9796	155.2676
9.0000	0.9700	150.2578	0.2433	60.2578	0.2433	60.2578	0.9700	150.2578
10.0000	0.9577	145.8281	0.2876	55.8281	0.2876	55.8281	0.9577	145.8281
11.0000	0.9413	140.2910	0.3375	50.2910	0.3375	50.2910	0.9413	140.2910
12.0000	0.9173	135.0703	0.3982	45.0703	0.3982	45.0703	0.9173	135.0703
13.0000	0.8825	128.2676	0.4703	38.2676	0.4703	38.2676	0.8825	128.2676

5. Strip Length = 151 mils

! DIELECTRIC THICKNESS = 31 MILS

! W/B=0.2

! STRIP LENGTH = 151 MILS

! DATA FROM STRIP PROGRAM

! FILE NAME: W020T151.s2p

! USER: John Muir

! DATE: 15 July 1991

! S-PARAMETER DATA

GHZ S MA R 50

! SCATTERING PARAMETERS:

! FREQ /S11/ <S11 /S21/ <S21 /S12/ <S12 /S22/ <S22

7.0000	0.9935	160.4355	0.1139	70.4355	0.1139	70.4355	0.9935	160.4355
8.0000	0.9892	155.5840	0.1467	65.5840	0.1467	65.5840	0.9892	155.5840
9.0000	0.9834	150.5215	0.1812	60.5215	0.1812	60.5215	0.9834	150.5215
10.0000	0.9751	145.8281	0.2218	55.8281	0.2218	55.8281	0.9751	145.8281
11.0000	0.9626	139.9746	0.2708	49.9746	0.2708	49.9746	0.9626	139.9746
12.0000	0.9420	134.0684	0.3357	44.0684	0.3357	44.0684	0.9420	134.0684
13.0000	0.9052	125.8945	0.4251	35.8945	0.4251	35.8945	0.9052	125.8945

6. Strip Length = 152 mils

! DIELECTRIC THICKNESS = 31 MILS

! W/B=0.2

! STRIP LENGTH = 152 MILS

! DATA FROM STRIP PROGRAM

! FILE NAME: W020T152.s2p

! USER: John Muir

! DATE: 15 July 1991

! S-PARAMETER DATA

GHZ S MA R 50

! SCATTERING PARAMETERS:

! FREQ /S11/ <S11 /S21/ <S21 /S12/ <S12 /S22/ <S22

7.0000	0.9935	160.4355	0.1139	70.4355	0.1139	70.4355	0.9935	160.4355
8.0000	0.9893	155.6367	0.1458	65.6367	0.1458	65.6367	0.9893	155.6367
9.0000	0.9838	150.5215	0.1794	60.5215	0.1794	60.5215	0.9838	150.5215

10.0000	0.9755	145.8281	0.2200	55.8281	0.2200	55.8281	0.9755	145.8281
11.0000	0.9631	139.9746	0.2691	49.9746	0.2691	49.9746	0.9631	139.9746
12.0000	0.9423	134.0156	0.3349	44.0156	0.3349	44.0156	0.9423	134.0156
13.0000	0.9056	125.8418	0.4242	35.8418	0.4242	35.8418	0.9056	125.8418

C. W/B=0.5

1. Strip Length = 101 mils

```
! DIELECTRIC THICKNESS = 31 MILS
! W/B=0.5
! STRIP LENGTH = 101 MILS
! DATA FROM STRIP PROGRAM
! FILE NAME: W050T101.s2p
! USER: John Muir
! DATE: 15 July 1991
```

! S-PARAMETER DATA

GHZ S MA R 50

! SCATTERING PARAMETERS:

! FREQ /S11/ <S11 /S21/ <S21 /S12/ <S12 /S22/ <S22

7.0000	0.9730	156.2695	0.2308	66.2695	0.2308	66.2695	0.9730	156.2695
8.0000	0.9491	148.0957	0.3148	58.0957	0.3148	58.0957	0.9491	148.0957
9.0000	0.9213	140.6074	0.3889	50.6074	0.3889	50.6074	0.9213	140.6074
10.0000	0.8885	133.6465	0.4589	43.6465	0.4589	43.6465	0.8885	133.6465
11.0000	0.8499	126.4219	0.5269	36.4219	0.5269	36.4219	0.8499	126.4219
12.0000	0.8056	118.5117	0.5925	28.5117	0.5925	28.5117	0.8056	118.5117
13.0000	0.7508	111.6035	0.6606	21.6035	0.6606	21.6035	0.7508	111.6035

2. Strip Length = 102 mils

```
! DIELECTRIC THICKNESS = 31 MILS
! W/B=0.5
! STRIP LENGTH = 102 MILS
! DATA FROM STRIP PROGRAM
! FILE NAME: W050T102.s2p
! USER: John Muir
! DATE: 15 July 1991
```

! S-PARAMETER DATA

GHZ S MA R 50

! SCATTERING PARAMETERS:

! FREQ /S11/ <S11 /S21/ <S21 /S12/ <S12 /S22/ <S22

7.0000	0.9734	156.2695	0.2290	66.2695	0.2290	66.2695	0.9734	156.2695
8.0000	0.9497	148.0957	0.3131	58.0957	0.3131	58.0957	0.9497	148.0957
9.0000	0.9220	140.6074	0.3872	50.6074	0.3872	50.6074	0.9220	140.6074
10.0000	0.8897	133.6992	0.4564	43.6992	0.4564	43.6992	0.8897	133.6992
11.0000	0.8514	126.4746	0.5246	36.4746	0.5246	36.4746	0.8514	126.4746
12.0000	0.8072	118.4590	0.5903	28.4590	0.5903	28.4590	0.8072	118.4590
13.0000	0.7520	111.4980	0.6592	21.4980	0.6592	21.4980	0.7520	111.4980

3. Strip Length = 149 mils

! DIELECTRIC THICKNESS = 31 MILS
! W/B=0.5
! STRIP LENGTH = 149 MILS
! DATA FROM STRIP PROGRAM
! FILE NAME: W050T149.s2p
! USER: John Muir
! DATE: 15 July 1991

! S-PARAMETER DATA

GHZ S MA R 50

! SCATTERING PARAMETERS:

! FREQ /S11/ <S11 /S21/ <S21 /S12/ <S12 /S22/ <S22

7.0000	0.9858	157.1133	0.1676	67.1133	0.1676	67.1133	0.9858	157.1133
8.0000	0.9719	148.9395	0.2352	58.9395	0.2352	58.9395	0.9719	148.9395
9.0000	0.9545	141.2930	0.2982	51.2930	0.2982	51.2930	0.9545	141.2930
10.0000	0.9307	133.9102	0.3659	43.9102	0.3659	43.9102	0.9307	133.9102
11.0000	0.8996	125.8945	0.4367	35.8945	0.4367	35.8945	0.8996	125.8945
12.0000	0.8576	116.6133	0.5144	26.6133	0.5144	26.6133	0.8576	116.6133
13.0000	0.7979	107.8594	0.6028	17.8594	0.6028	17.8594	0.7979	107.8594

4. Strip Length = 151 mils

! DIELECTRIC THICKNESS = 31 MILS
! W/B=0.5
! STRIP LENGTH = 151 MILS
! DATA FROM STRIP PROGRAM
! FILE NAME: W050T151.s2p
! USER: John Muir
! DATE: 15 July 1991

! S-PARAMETER DATA

GHZ S MA R 50

! SCATTERING PARAMETERS:

! FREQ /S11/ <S11 /S21/ <S21 /S12/ <S12 /S22/ <S22

7.0000	0.9862	157.1133	0.1658	67.1133	0.1658	67.1133	0.9862	157.1133
8.0000	0.9728	148.9395	0.2317	58.9395	0.2317	58.9395	0.9728	148.9395
9.0000	0.9553	141.3457	0.2956	51.3457	0.2956	51.3457	0.9553	141.3457
10.0000	0.9320	133.9102	0.3625	43.9102	0.3625	43.9102	0.9320	133.9102
11.0000	0.9012	125.8945	0.4334	35.8945	0.4334	35.8945	0.9012	125.8945
12.0000	0.8590	116.5605	0.5120	26.5605	0.5120	26.5605	0.8590	116.5605
13.0000	0.7990	107.6484	0.6014	17.6484	0.6014	17.6484	0.7990	107.6484

5. Strip Length = 200 mils

! DIELECTRIC THICKNESS = 31 MILS
! W/B= 0.5
! STRIP LENGTH = 200 MILS
! DATA FROM STRIP PROGRAM
! FILE NAME: W05T200.s2p
! USER: John Muir
! DATE: 18 June 1991

```

! S-PARAMETER DATA
# GHZ S MA R 50
! SCATTERING PARAMETERS:
! FREQ /S11/ <S11 /S21/ <S21 /S12/ <S12 /S22/ <S22

7.0000 0.9925 157.5352 0.1221 67.5352 0.1221 67.5352 0.9925 157.5352
8.0000 0.9847 149.3613 0.1740 59.3613 0.1740 59.3613 0.9847 149.3613
9.0000 0.9734 141.6094 0.2290 51.6094 0.2290 51.6094 0.9734 141.6094
10.0000 0.9572 133.9102 0.2894 43.9102 0.2894 43.9102 0.9572 133.9102
11.0000 0.9320 125.2617 0.3625 35.2617 0.3625 35.2617 0.9320 125.2617
12.0000 0.8931 114.9258 0.4499 24.9258 0.4499 24.9258 0.8931 114.9258
13.0000 0.8284 104.1152 0.5602 14.1152 0.5602 14.1152 0.8284 104.1152

```

D. W/B=1.0

1. Strip Length = 202 mils

```

! DIELECTRIC THICKNESS = 31 MILS
! W/B=1.0
! STRIP LENGTH = 202 MILS
! DATA FROM STRIP PROGRAM
! FILE NAME: W10T202.s2p
! USER: John Muir
! DATE: 15 July 1991

```

```

! S-PARAMETER DATA
# GHZ S MA R 50
! SCATTERING PARAMETERS:
! FREQ /S11/ <S11 /S21/ <S21 /S12/ <S12 /S22/ <S22

7.0000 0.9915 160.0137 0.1303 70.0137 0.1303 70.0137 0.9915 160.0137
8.0000 0.9734 146.5664 0.2290 56.5664 0.2290 56.5664 0.9734 146.5664
9.0000 0.9489 134.6484 0.3157 44.6484 0.3157 44.6484 0.9489 134.6484
10.0000 0.9162 123.4160 0.4007 33.4160 0.4007 33.4160 0.9162 123.4160
11.0000 0.8719 112.1309 0.4897 22.1309 0.4897 22.1309 0.8719 112.1309
12.0000 0.8115 100.9512 0.5843 10.9512 0.5843 10.9512 0.8115 100.9512
13.0000 0.7322 88.7168 0.6811 -1.2832 0.6811 -1.2832 0.7322 88.7168

```

2. Strip Length = 204 mils

```

! DIELECTRIC THICKNESS = 31 MILS
! W/B=1.0
! STRIP LENGTH = 204 MILS
! DATA FROM STRIP PROGRAM
! FILE NAME: W10T204.s2p
! USER: John Muir
! DATE: 15 July 1991

```

```

! S-PARAMETER DATA
# GHZ S MA R 50
! SCATTERING PARAMETERS:
! FREQ /S11/ <S11 /S21/ <S21 /S12/ <S12 /S22/ <S22

7.0000 0.9918 160.0664 0.1276 70.0664 0.1276 70.0664 0.9918 160.0664
8.0000 0.9743 146.5664 0.2254 56.5664 0.2254 56.5664 0.9743 146.5664
9.0000 0.9500 134.6484 0.3122 44.6484 0.3122 44.6484 0.9500 134.6484
10.0000 0.9177 123.4160 0.3974 33.4160 0.3974 33.4160 0.9177 123.4160

```

11.0000 0.8737 112.1309 0.4865 22.1309 0.4865 22.1309 0.8737 112.1309
12.0000 0.8137 100.8457 0.5813 10.8457 0.5813 10.8457 0.8137 100.8457
13.0000 0.7341 88.5586 0.6790 -1.4414 0.6790 -1.4414 0.7341 88.5586

3. Strip Length = 251 mils

! DIELECTRIC THICKNESS = 31 MILS
! W/B=1.0
! STRIP LENGTH = 251 MILS
! DATA FROM STRIP PROGRAM
! FILE NAME: W10T251.s2p
! USER: John Muir
! DATE: 15 July 1991

! S-PARAMETER DATA

GHZ S MA R 50

! SCATTERING PARAMETERS:

! FREQ /S11/ <S11 /S21/ <S21 /S12/ <S12 /S22/ <S22

7.0000 0.9953 160.3828 0.0965 70.3828 0.0965 70.3828 0.9953 160.3828
8.0000 0.9847 147.0410 0.1740 57.0410 0.1740 57.0410 0.9847 147.0410
9.0000 0.9686 135.0703 0.2486 45.0703 0.2486 45.0703 0.9686 135.0703
10.0000 0.9450 123.4160 0.3271 33.4160 0.3271 33.4160 0.9450 123.4160
11.0000 0.9087 111.3926 0.4175 21.3926 0.4175 21.3926 0.9087 111.3926
12.0000 0.8518 98.8945 0.5238 8.8945 0.5238 8.8945 0.8518 98.8945
13.0000 0.7652 84.3926 0.6438 -5.6074 0.6438 -5.6074 0.7652 84.3926

4. Strip Length = 253 mils

! DIELECTRIC THICKNESS = 31 MILS
! W/B=1.0
! STRIP LENGTH = 253 MILS
! DATA FROM STRIP PROGRAM
! FILE NAME: W10T253.s2p
! USER: John Muir
! DATE: 15 July 1991

! S-PARAMETER DATA

GHZ S MA R 50

! SCATTERING PARAMETERS:

! FREQ /S11/ <S11 /S21/ <S21 /S12/ <S12 /S22/ <S22

7.0000 0.9954 160.3301 0.0956 70.3301 0.0956 70.3301 0.9954 160.3301
8.0000 0.9851 147.0410 0.1722 57.0410 0.1722 57.0410 0.9851 147.0410
9.0000 0.9693 135.1230 0.2460 45.1230 0.2460 45.1230 0.9693 135.1230
10.0000 0.9459 123.4688 0.3244 33.4688 0.3244 33.4688 0.9459 123.4688
11.0000 0.9098 111.4453 0.4150 21.4453 0.4150 21.4453 0.9098 111.4453
12.0000 0.8538 98.7891 0.5207 8.7891 0.5207 8.7891 0.8538 98.7891
13.0000 0.7669 84.2344 0.6417 -5.7656 0.6417 -5.7656 0.7669 84.2344

5. Strip Length = 301 mils

! DIELECTRIC THICKNESS = 31 MILS
! W/B=1.0
! STRIP LENGTH = 301 MILS
! DATA FROM STRIP PROGRAM
! FILE NAME: W10T301.s2p

! USER: John Muir
! DATE: 15 July 1991

! S-PARAMETER DATA

GHZ S MA R 50

! SCATTERING PARAMETERS:

! FREQ /S11/ <S11 /S21/ <S21 /S12/ <S12 /S22/ <S22

7.0000	0.9974	160.5410	0.0717	70.5410	0.0717	70.5410	0.9974	160.5410
8.0000	0.9911	147.3047	0.1331	57.3047	0.1331	57.3047	0.9911	147.3047
9.0000	0.9808	135.2812	0.1948	45.2812	0.1948	45.2812	0.9808	135.2812
10.0000	0.9639	123.4688	0.2664	33.4688	0.2664	33.4688	0.9639	123.4688
11.0000	0.9350	110.8652	0.3547	20.8652	0.3547	20.8652	0.9350	110.8652
12.0000	0.8829	97.1016	0.4695	7.1016	0.4695	7.1016	0.8829	97.1016
13.0000	0.7889	80.3320	0.6145	-9.6680	0.6145	-9.6680	0.7889	80.3320

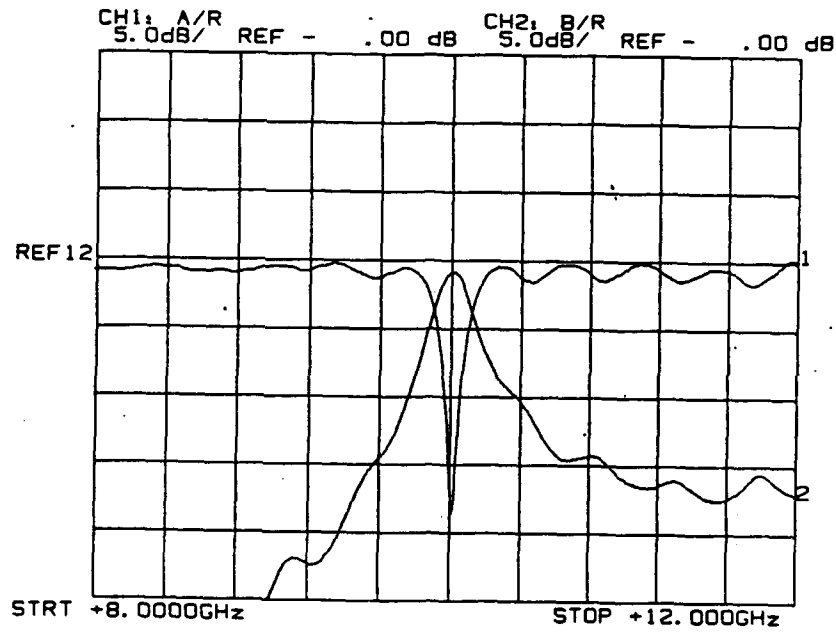

Figure 9. Filter 2 Frequency Response from Experiment: $W/B = 1.0$

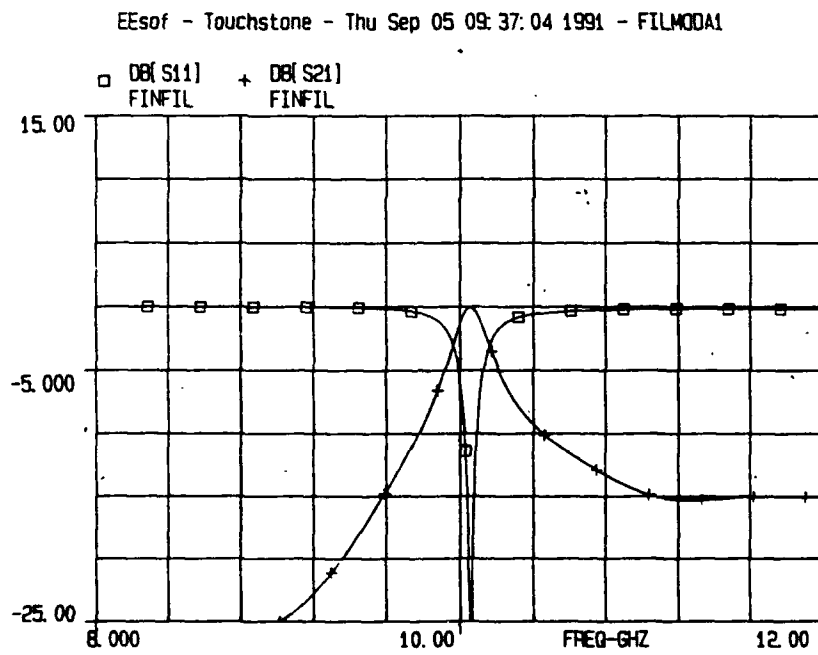

Figure 10. Filter 2 Frequency Response from Model A1: $W/B = 1.0$

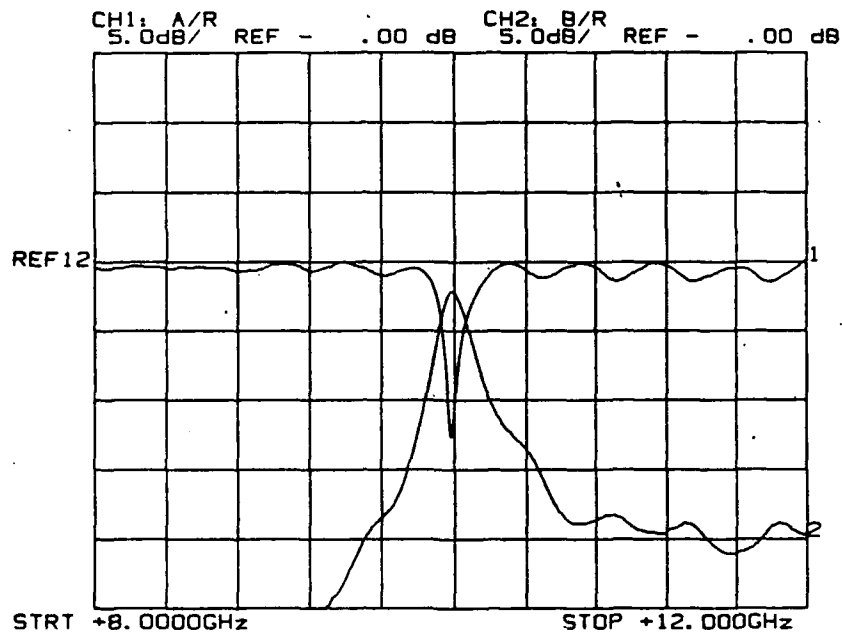

Figure 11. Filter 3 Frequency Response from Experiment: $W/B = 1.0$

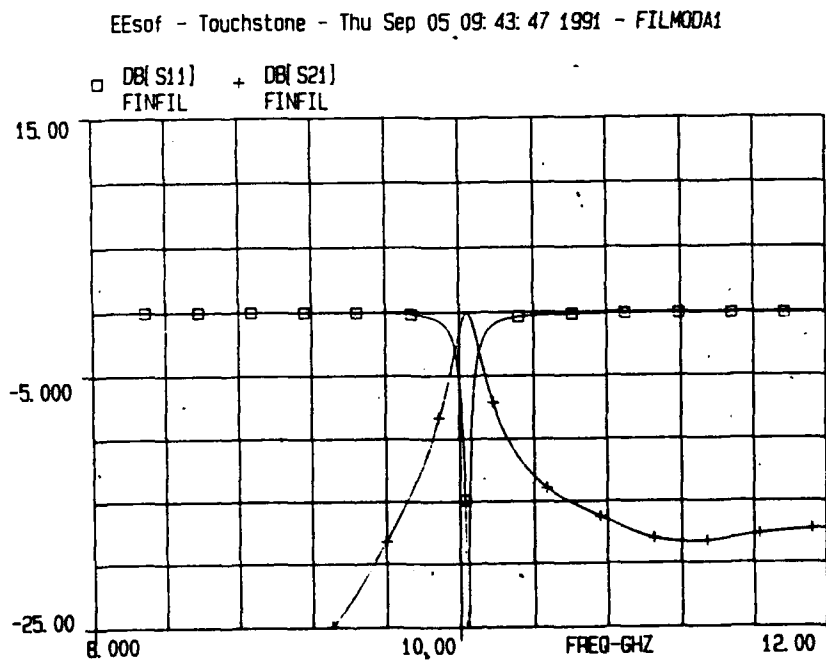

Figure 12. Filter 3 Frequency Response from Model A1: $W/B = 1.0$

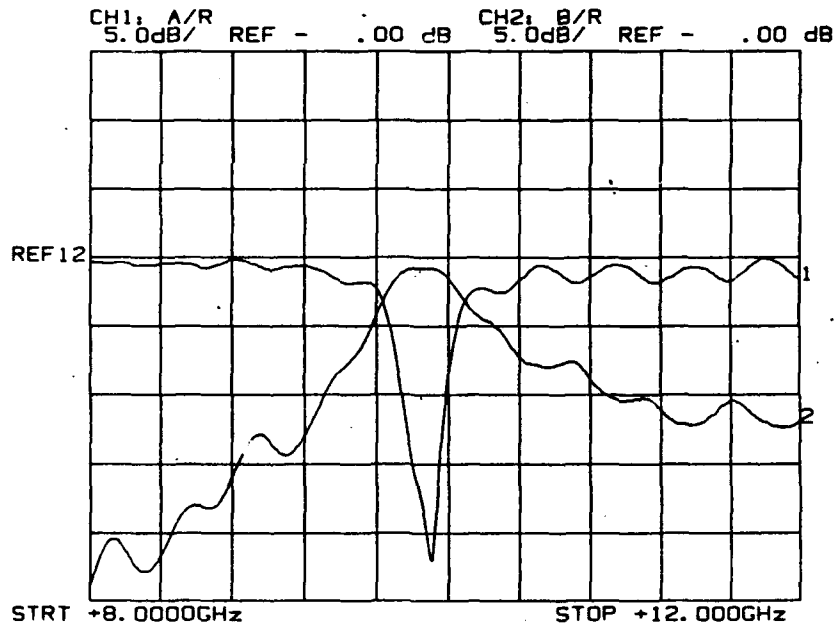

Figure 13. Filter 4 Frequency Response from Experiment: $W/B = 0.5$

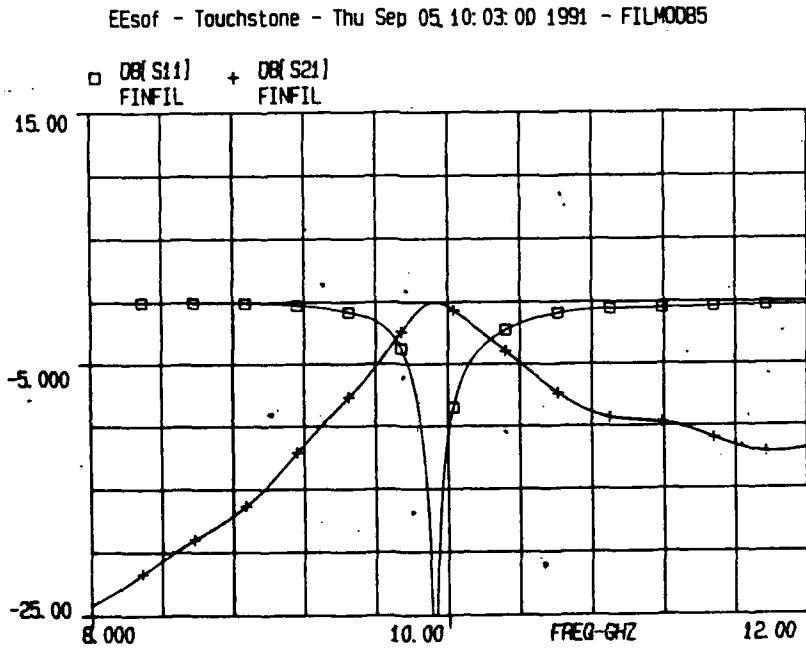

Figure 14. Filter 4 Frequency Response from Model B: $W/B = 0.5$

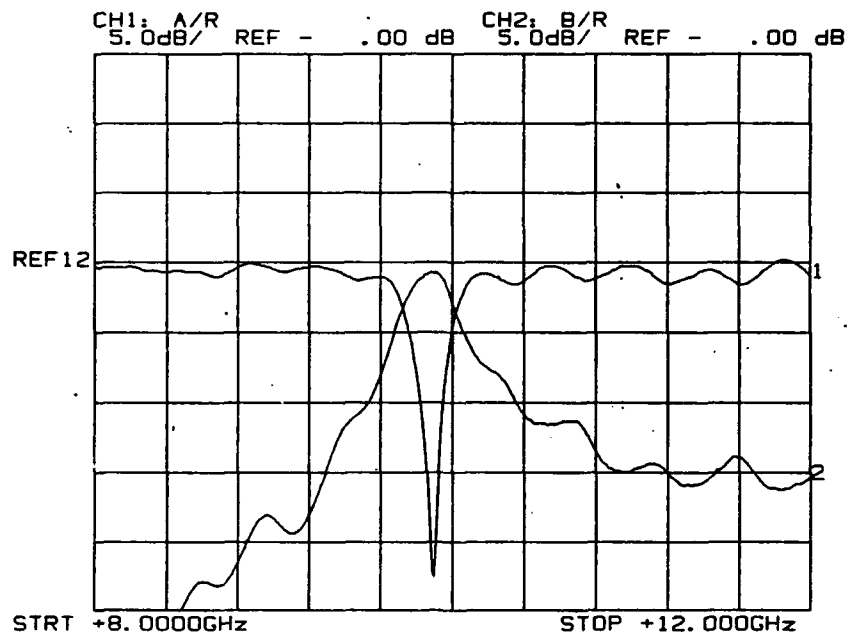

Figure 15. Filter 5 Frequency Response from Experiment: $W/B=0.5$

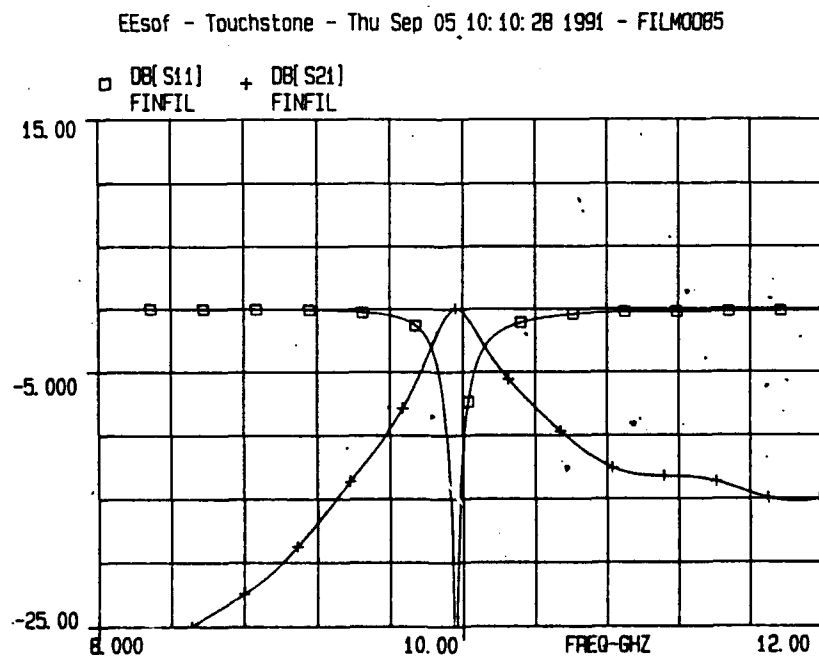

Figure 16. Filter 5 Frequency Response from Model B: $W/B=0.5$

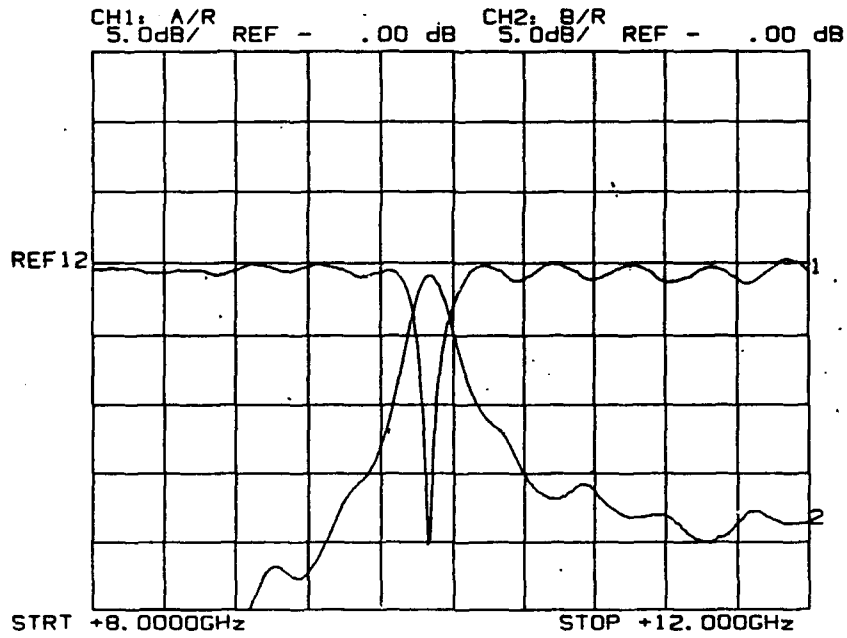

Figure 17. Filter 6 Frequency Response from Experiment: $W/B = 0.5$

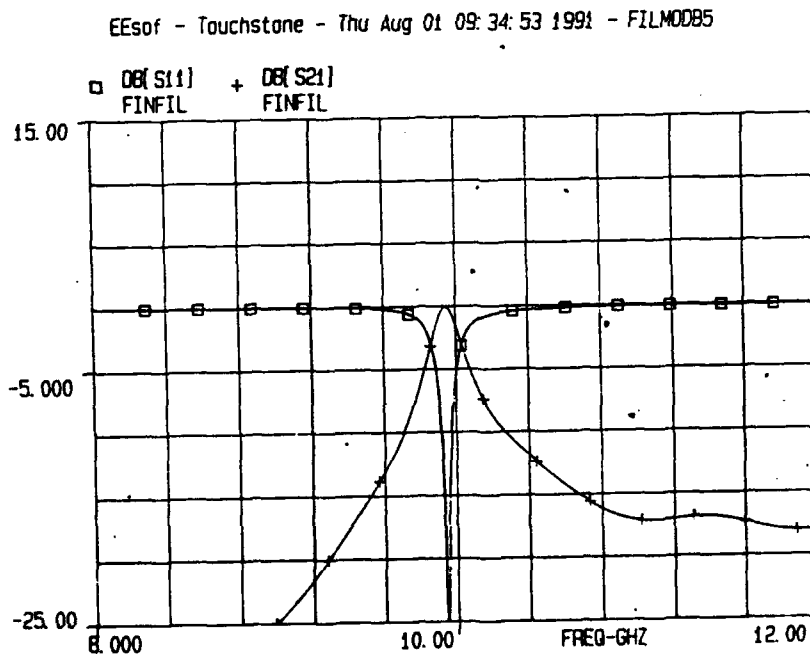

Figure 18. Filter 6 Frequency Response from Model B: $W/B = 0.5$

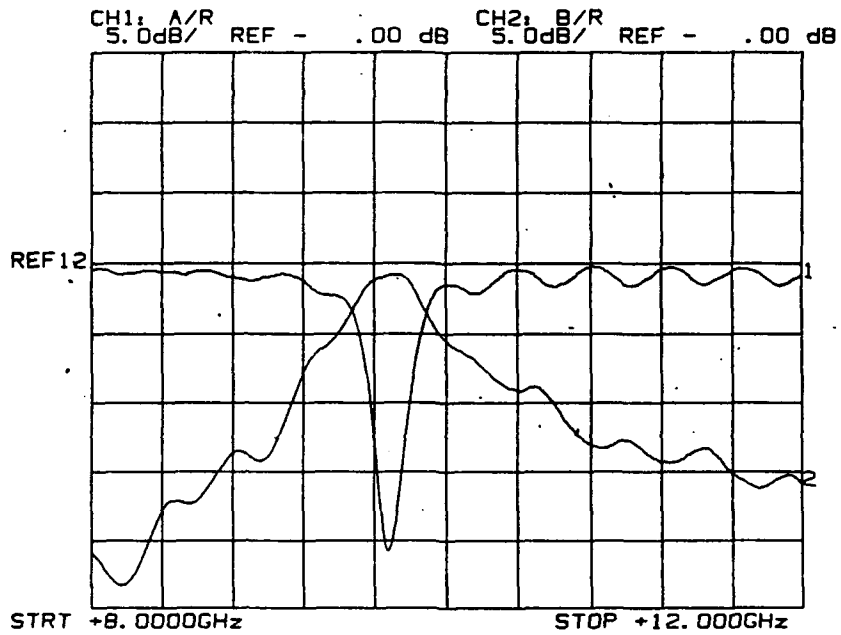

Figure 19. Filter 7 Frequency Response from Experiment: $W/B=0.2$

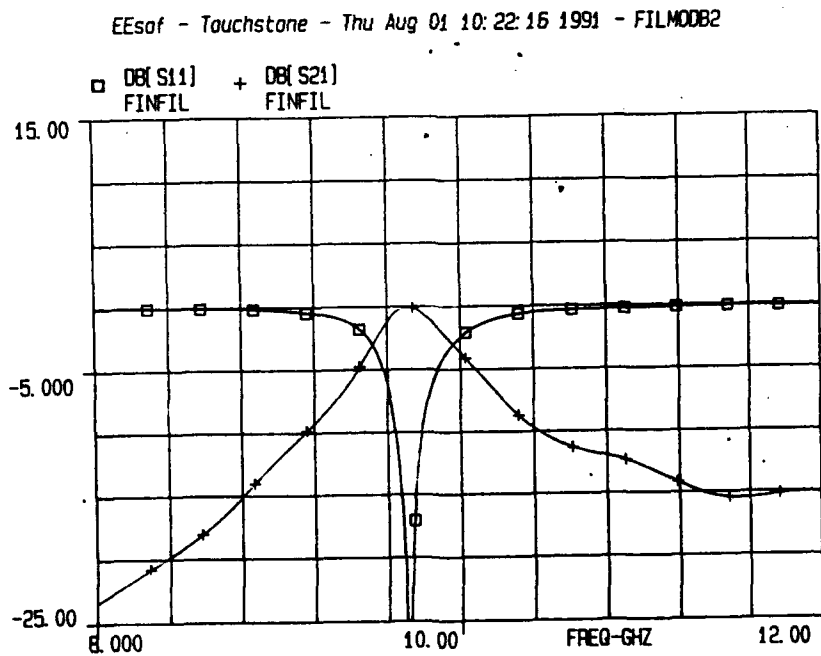

Figure 20. Filter 7 Frequency Response from Model B: $W/B=0.2$

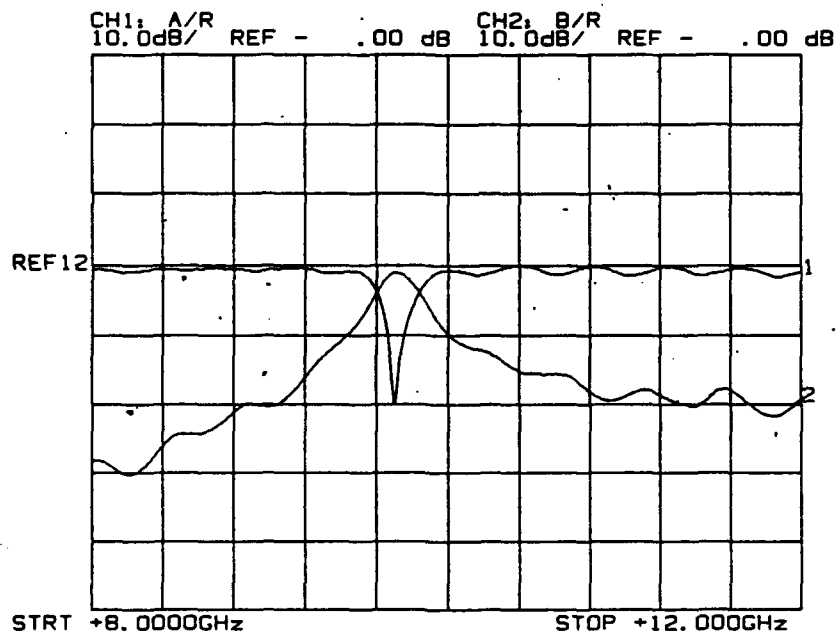

Figure 21. Filter 8 Frequency Response from Experiment: $W/B = 0.2$

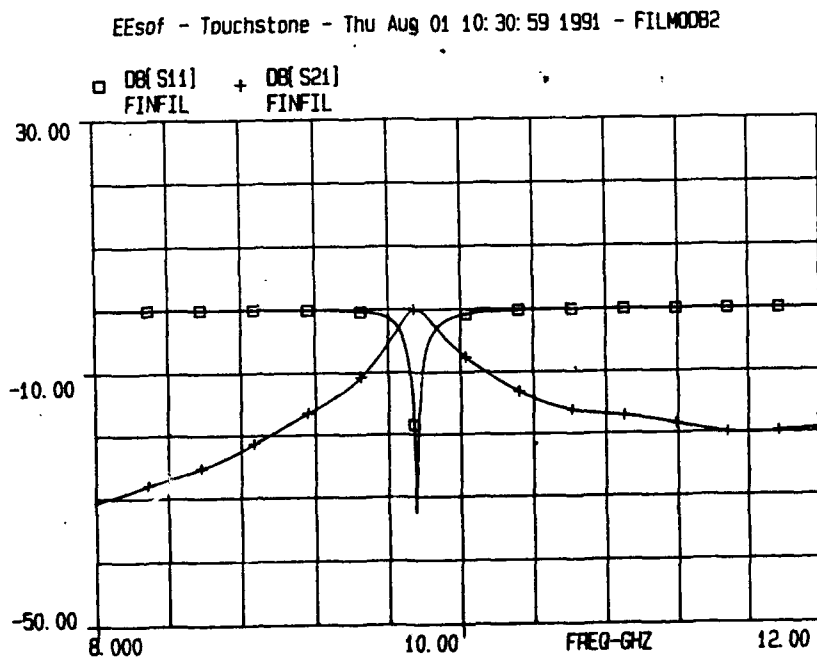

Figure 22. Filter 8 Frequency Response from Model B: $W/B = 0.2$

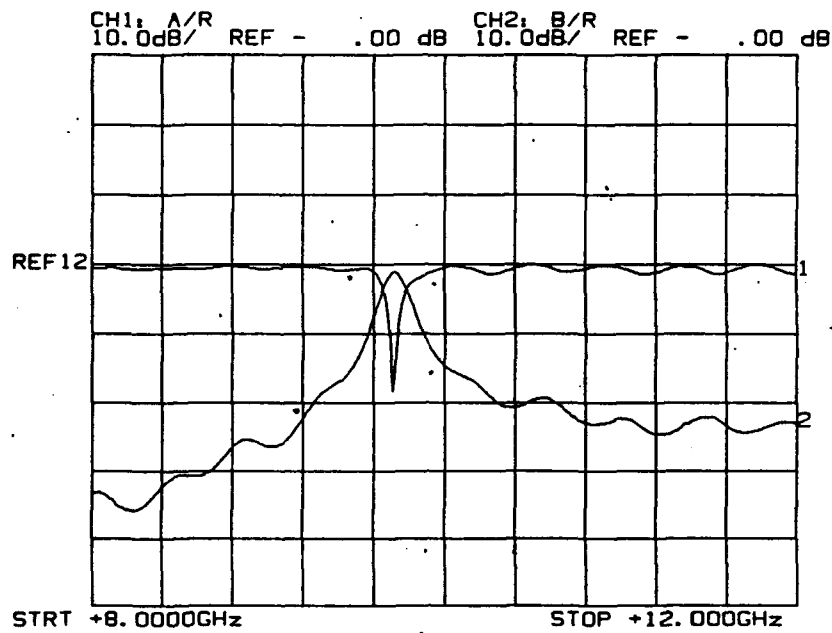

Figure 23. Filter 9 Frequency Response from Experiment: $W/B=0.2$

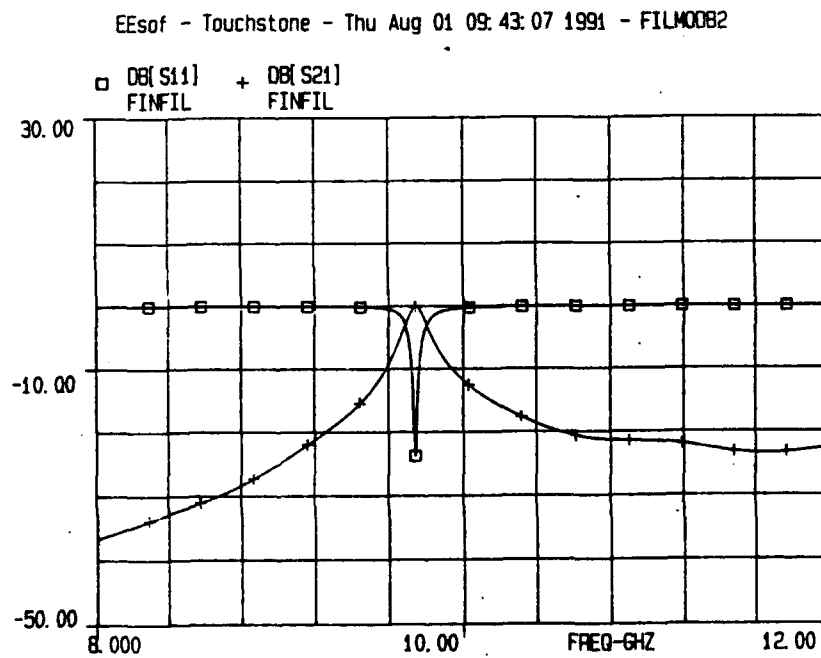

Figure 24. Filter 9 Frequency Response from Model B: $W/B=0.2$

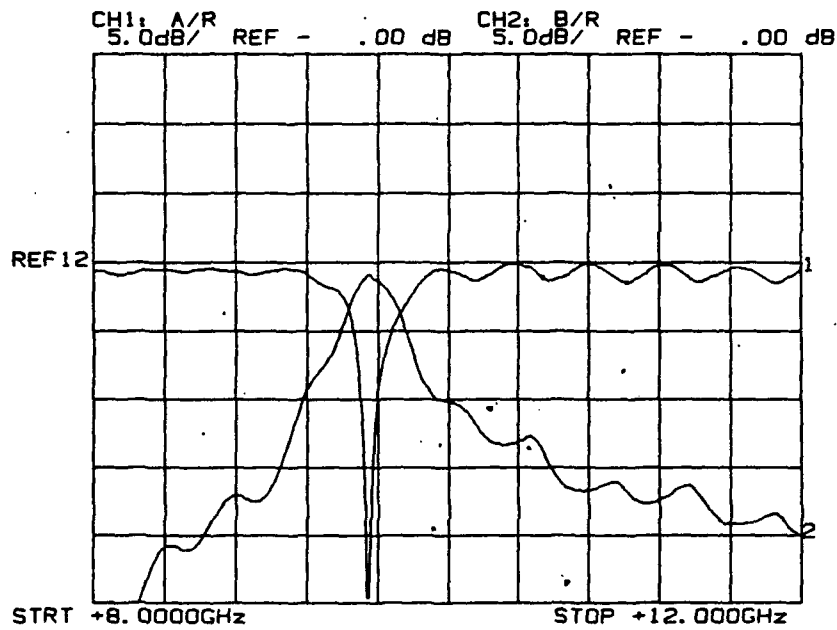

Figure 25. Filter 10 Frequency Response from Experiment: $W/B = 0.1$

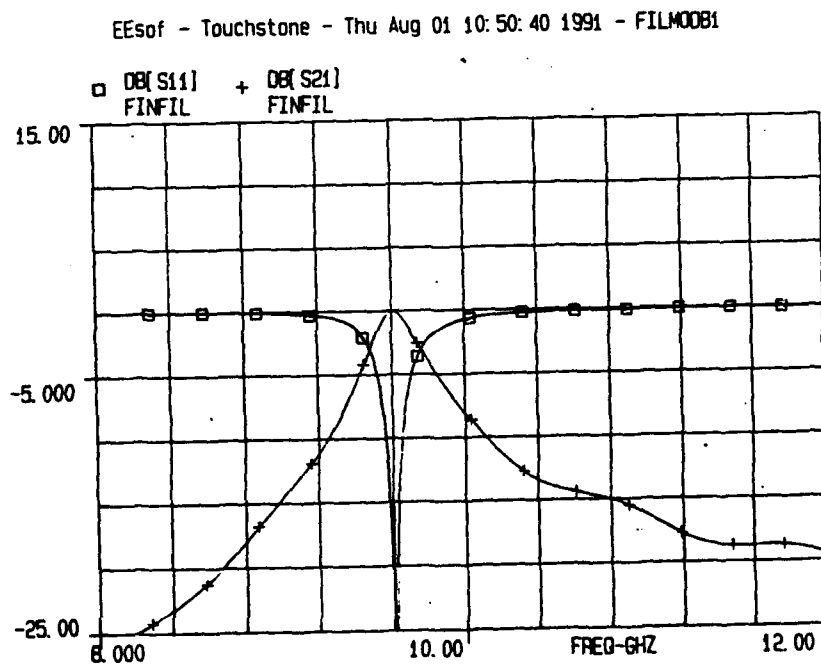

Figure 26. Filter 10 Frequency Response from Model B: $W/B = 0.1$

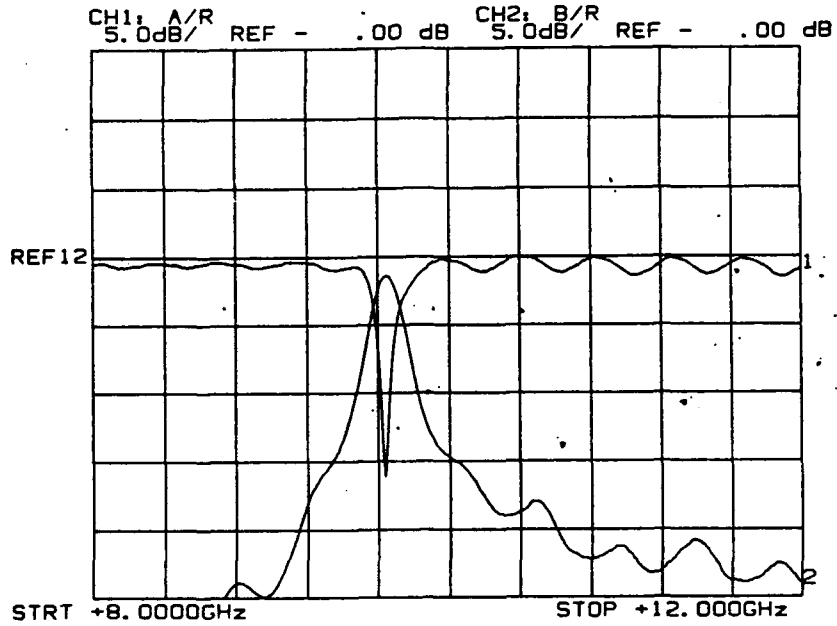

Figure 27. Filter 11 Frequency Response from Experiment: $W/B=0.1$

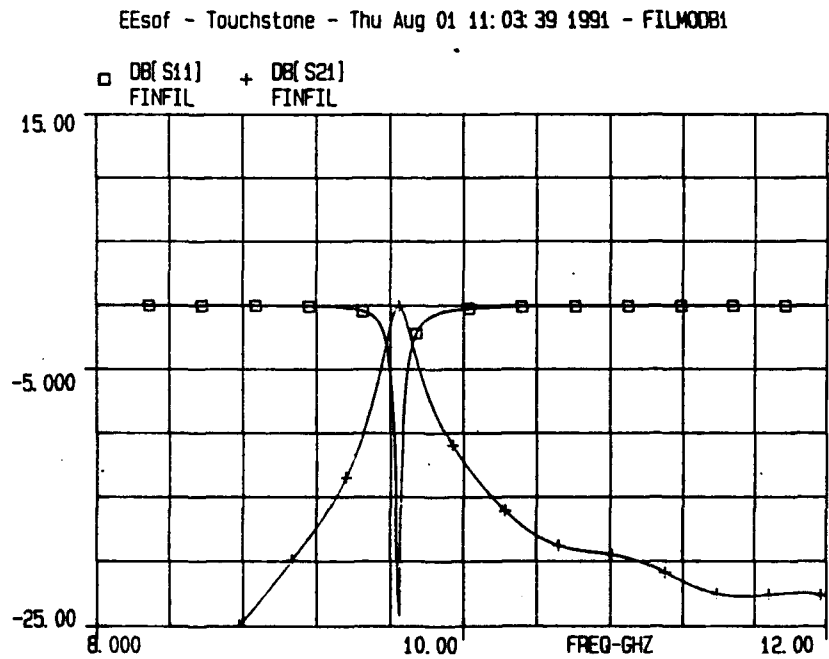

Figure 28. Filter 11 Frequency Response from Model B: $W/B=0.1$

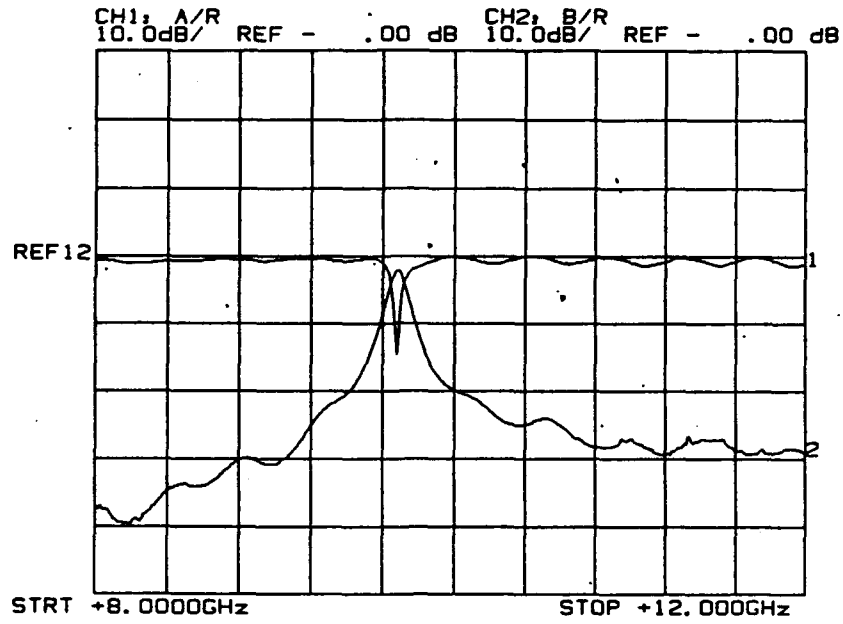

Figure 29. Filter 12 Frequency Response from Experiment: $W/B=0.1$

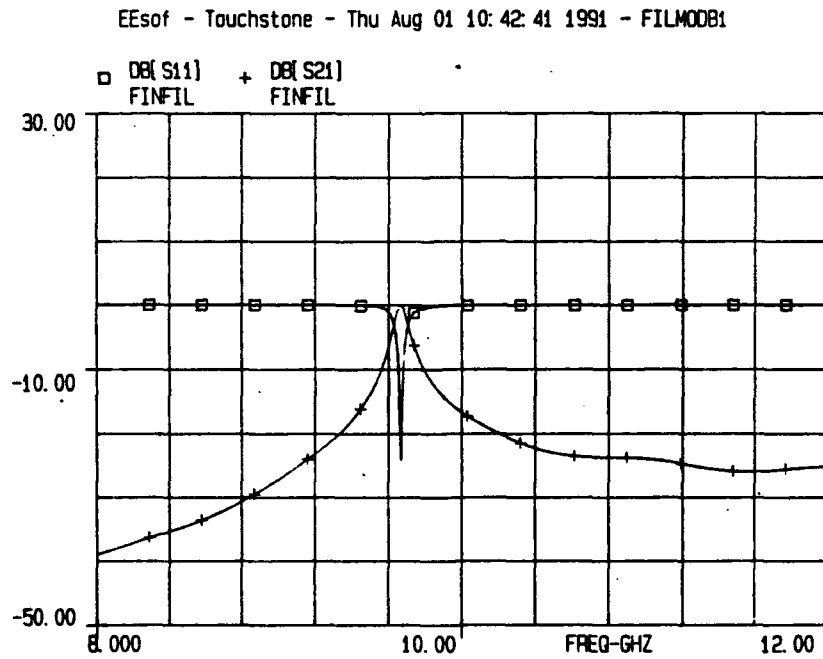

Figure 30. Filter 12 Frequency Response from Model B: $W/B=0.1$

LIST OF REFERENCES

1. Meier, P.J., "Integrated fin-line millimeter components," *IEEE Transactions on Microwave Theory and Techniques*, Vol. MTT-22, pp. 1209-1216, December 1974.
2. Shayda, P.M., *Spectral domain analysis of finline*, M.S. Thesis, Naval Postgraduate School, Monterey, CA, December 1979.
3. Knorr, J.B. and Shayda, P.M., "Millimeter-wave fin-line characteristics", *IEEE Transactions on Microwave Theory and Techniques*, vol. MTT-28, pp. 737-742, July 1980.
4. Kim, B., *A Computation of Fin-line Impedance*, M.S. Thesis, Naval Postgraduate School, Monterey, CA, December 1984.
5. Knorr, Jeffrey B. and Deal, John C., "Scattering Coefficients of an Inductive Strip in a Finline: Theory and Experiment," *IEEE Transactions on Microwave Theory and Techniques*, Vol. MTT-33, pp. 1011-1017, October 1985.
6. Deal, J. C., *Numerical Computation of the Scattering Coefficients of an Inductive Strip in Fin-line: Theory and Experiment*, M.S. Thesis, Naval Postgraduate School, Monterey, CA, March 1984.
7. Morua, Michael, L., *A Circuit Model for an Inductive Strip in Homogeneous Finline*, M.S. Thesis, Naval Postgraduate School, Monterey, CA, June 1990.
8. Grohsmeyer, Janeen, *Analytical Expressions for Impedance and Wavelength in Inhomogeneous Finline*, Unpublished Report, Naval Postgraduate School, Monterey, CA, November 1990.
9. Knorr, J. B., *CAD Models for Inductive Strips in Homogeneous Finline: the Methodology*. Technical report NPS 62-90-007, Naval Postgraduate School, Monterey, CA. March 1990.

10. Miller, Guy, Steven, *An Experimental Investigation of Several Fin-Line Discontinuities*, M.S. Thesis, Naval Postgraduate School, Monterey, CA, December 1980.

INITIAL DISTRIBUTION LIST

	No. Copies
1. Defense Technical Information Center Cameron Station Alexandria, VA 22304-6145	2
2. Library, Code 52 Naval Postgraduate School Monterey, CA 93943-5002	2
3. Chairman, Code EC Department of Electrical and Computer Engineering Naval Postgraduate School Monterey, CA 93943-5000	1
4. Professor J.B. Knorr, Code EC/Ko Department of Electrical and Computer Engineering Naval Postgraduate School Monterey, CA 93943-5000	3
5. Professor R. Janaswamy, Code EC/Js Department of Electrical and Computer Engineering Naval Postgraduate School Monterey, CA 93943-5000	1
6. Commanding Officer Microwave/Millimeter Wave Branch (Attn: Dave Rubin, Code 753) Naval Oceans Systems Center San Diego, CA 92152	1
7. Commanding Officer RF Development Section (Attn: Joe Mosko, Code 35203) Naval Weapons Center China Lake, CA 93555	1
8. DLAEEM 4-3 National Defence Headquarters Ottawa, Ontario, Canada K1A 0K2	2
9. Capt J. P. Muir, Canadian Forces PO Box 192 Thorold, Ontario, Canada L2V 3Y9	2