

2

NAVAL POSTGRADUATE SCHOOL

Monterey, California

AD-A247 479

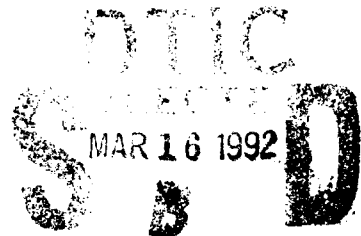

THESIS

ANALYSIS OF NAVADS SMALL PARCEL SHIPPING POLICY

by

Benedicto Librado Coloma

March, 1992

Thesis Advisor: Dan C. Boger

Approved for public release; distribution is unlimited

92-06537



025

**Best
Available
Copy**

REPORT DOCUMENTATION PAGE			
1a REPORT SECURITY CLASSIFICATION UNCLASSIFIED		1b RESTRICTIVE MARKINGS	
2a SECURITY CLASSIFICATION AUTHORITY		3 DISTRIBUTION AVAILABILITY OF REPORT Approved for public release; distribution is unlimited.	
2b DECLASSIFICATION/DOWNGRADING SCHEDULE			
4 PERFORMING ORGANIZATION REPORT NUMBER(S)		5 MONITORING ORGANIZATION REPORT NUMBER(S)	
6a NAME OF PERFORMING ORGANIZATION Naval Postgraduate School	6b OFFICE SYMBOL (if applicable) 55	7a NAME OF MONITORING ORGANIZATION Naval Postgraduate School	
6c ADDRESS (City, State, and ZIP Code) Monterey, CA 93943-5000		7b ADDRESS (City, State, and ZIP Code) Monterey, CA 93943-5000	
8a NAME OF FUNDING SPONSORING ORGANIZATION	8b OFFICE SYMBOL (if applicable)	9 PROCUREMENT INSTRUMENT IDENTIFICATION NUMBER	
8c ADDRESS (City, State, and ZIP Code)		10 SOURCE OF FUNDING NUMBERS	
		Program Element No.	Project No.
		Task No.	Work Unit/Accession Number
11 TITLE (Include Security Classification) ANALYSIS OF NAVADS SMALL PARCEL SHIPPING POLICY			
12 PERSONAL AUTHOR(S) Coloma, Benedicto Labrado			
13a TYPE OF REPORT Master's Thesis	13b TIME COVERED From To	14 DATE OF REPORT (year, month, day) 1992 March	15 PAGE COUNT 74
16 SUPPLEMENTARY NOTATION The views expressed in this thesis are those of the author and do not reflect the official policy or position of the Department of Defense or the U.S. Government			
17 COSATI CODES		18 SUBJECT TERMS (continue on reverse if necessary and identify by block number)	
FIELD	GROUP	SUBGROUP	
		Shipment policy, Modes of shipment, NISTARS, NAVADS, Navy Logistics	
19 ABSTRACT (continue on reverse if necessary and identify by block number)			
NSC San Diego stocks material and spare parts essential to support both the support activities and the operating forces. To fulfill this responsibility, NSC San Diego employs various shipping methodologies to get the required materials to customers, and it attempts to do this at the lowest possible cost. This thesis focuses on the small parcel shipping policy that governs the determination of the mode of shipment. The shipping factors analyzed are the small parcel package routing policy, the interlace of NAVADS and NISTARS in mode-of-shipment determination, and the cost savings that have occurred by manually overriding the NAVADS recommendations.			
20 DISTRIBUTION AVAILABILITY OF ABSTRACT <input checked="" type="checkbox"/> Available in AD/AS <input checked="" type="checkbox"/> Available in AD/AS <input type="checkbox"/> Available in AD/AS		21 ABSTRACT SECURITY CLASSIFICATION Unclassified	
22a NAME OF RESPONSIBLE INDIVIDUAL Professor Dan C. Beger		22b TELEPHONE (Include Area code) (408) 646-2607	22c OFFICE SYMBOL Com ASB

Approved for public release; distribution is unlimited.

Analysis of NAVADS Small Parcel Shipping Policy

by
Benedicto Librado Coloma
Lieutenant, Supply Corps, United States Navy
B.S., Hawaii Pacific College

Submitted in partial fulfillment
of the requirements for the degree of

MASTER OF SCIENCE IN MANAGEMENT

from the

NAVAL POSTGRADUATE SCHOOL
March 1992

Author:



Benedicto Librado Coloma

Approved by:

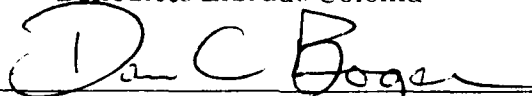

Dan C. Boger, Principal Advisor



Alan W. McMasters, Associate Advisor



David R. Whipple, Chairman
Department of Administrative Sciences

TABLE OF CONTENTS

I. INTRODUCTION	1
A. BACKGROUND	1
B. THESIS OBJECTIVE	1
C. SCOPE	2
D. METHODOLOGY	2
E. PREVIEW	2
II. NAVY LOGISTICS ORGANIZATION	4
A. NAVY LOGISTICS SYSTEM	4
1. Functions of the Navy Logistics System	4
2. Organizational responsibilities of the Naval Logistics System	5
B. MANAGEMENT OF NAVY TRANSPORTATION	7
III. SHIPPING POLICY	8
A. BACKGROUND	8
B. NAVSUP SHIPPING POLICY	8
C. NAVSUP SMALL PARCEL SHIPPING POLICY	9
1. Mode of transportation selection	10

2.	Size and weight limitation	10
D.	ROUTING OF FREIGHT	11
E.	SHIPPING NETWORK	12
1.	QUICKTRANS	12
2.	CONTRUCK	12
3.	Standing Route Orders	13
4.	Guaranteed Traffic	13
5.	Freight Forwarders	14
6.	U. S. Postal Service	14
7.	Organic Transportation	15
IV.	NISTARS AND NAVADS AT NSC SAN DIEGO	16
A.	NISTARS	16
B.	NAVADS	17
C.	NSC SAN DIEGO SMALL PARCEL POLICY	18
D.	UADPS-SP/NAVADS INTERFACE	19
E.	MODE OF SHIPMENT CHANGES	20
F.	NAVADS MODE OF SHIPMENT LOGIC FLOW	26
V.	ANALYSIS OF SMALL PARCEL SHIPMENT AT NSC SAN DIEGO	33
A.	NSC SAN DIEGO MODE OF SHIPMENT PROFILE	33
B.	COST OF TRANSPORTATION AS DETERMINED BY NAVADS ..	33

VI. MANAGERIAL ISSUES IN SMALL PARCEL SHIPMENTS	38
A. NSC SAN DIEGO INITIATIVES	38
1. Measures of Effectiveness	39
2. Management Initiative	39
B. NAVSUP ISSUES	40
1. Advantages	40
2. Disadvantages	41
VII. SUMMARY AND CONCLUSION	43
A. SUMMARY	43
B. CONCLUSIONS	44
C. RECOMMENDATIONS	44
APPENDIX A	46
APPENDIX B	47
APPENDIX C	48
LIST OF REFERENCES	66
INITIAL DISTRIBUTION LIST	67

I. INTRODUCTION

A. BACKGROUND

The Department of the Navy spends approximately an average of \$375 million annually on transportation cost. For commercial transportation costs alone, both air and surface, the Navy spends an average of \$45.5 million for first destination and about \$120.5 million for second destination shipments. [Ref. 1]

Declining budget trends and the rising cost of transportation have prompted many Navy top managers and directors including Naval Supply Systems Command (NAVSUP) to review current shipping policies to find where the Navy as a whole can reduce or avoid excessive cost.

B. THESIS OBJECTIVE

The primary objective of this thesis is to analyze NAVSUP shipping policies and how they are implemented, particularly at the stock points. Specific analysis is focused on Navy Integrated Storage, Tracking and Retrieval System (NISTARS) small parcel shipping policies to determine the cost-effectiveness of the shipping methodologies currently in place at Naval Supply Center, San Diego, and to determine the degree of management involvement in the shipping process. Secondly, analysis will also assess the interface between the Navy Automated Transportation Documentation System (NAVADS) and NISTARS.

C. SCOPE

This analysis focuses on NSC San Diego NISTARS small parcel shipping policies. NSC San Diego manages approximately 500,000 individual National Stock Numbers (NSN). Of those, 172,000 are under NISTARS control and located in the mechanized warehouse; an additional 13,000 NSNs are also under NISTARS control but are located in non-mechanized warehouses. [Ref. 2:p. 7] Over 62 percent of these stocked items is small parcel eligible if one unit of each item is requisitioned and shipped individually. This analysis examines data compiled only between March 1991 and June 1991.

D. METHODOLOGY

This analysis uses shipping document copies, DD Form 1348-1, provided by NSC San Diego Shipping Department, Code 401, and selected reports provided by the NSC San Diego Computer Center which support the NISTARS automated warehouse operation. These documents will be used to determine how NISTARS shipping policies are implemented. The DD Form 1348-1's are required because they indicate proof of shipment and specific actions employed by the Shipping Department to effect the shipment of material. Selected computer reports are required because they list all requisitions entering NSC San Diego between March 1991 and June 1991.

E. PREVIEW

Chapter II provides an overview of the Naval logistics organization and the Naval Supply System, delineating responsibilities as they apply to logistic support and transportation management. Chapter III identifies NAVSUP shipping policy and also

outlines how that policy is implemented at NSC San Diego. Chapter IV outlines NISTARS and NAVADS systems and operations, and discusses the interface of the two systems in the determination of shipment modes. Chapter V analyzes the small parcel shipments at NSC San Diego and shows the impact of shipment mode changes in terms of transportation cost avoidance. Chapter VI outlines managerial issues at NSC San Diego, and it discusses some of the advantages and disadvantages of the current small parcel shipping policy. Chapter VII provides conclusions and recommendations.

II. NAVY LOGISTICS ORGANIZATION

The purpose of this chapter is to provide an overview of the functions and organizational responsibilities of the Navy logistics system, the Navy Transportation System, and the Navy Supply System. The first section will describe the functions of the Navy logistics system and responsibilities within the Navy logistics organization. The second section will focus on management of Navy transportation. The last section will describe the functions of the Navy supply system.

A. NAVY LOGISTICS SYSTEM

The Navy logistics system is tasked with the planning, programming, budgeting and execution of the movement and in-service support logistics requirements of the operating forces. [Ref. 3:p 2]

1. Functions of the Navy Logistics System

The responsibilities of the Navy Logistics System cover a broad range of actions including design, development, acquisition, storage, movement, distribution and disposition of materials. Design, maintenance and disposal of facilities and determination of training requirements for personnel also fall within the purview of naval logistics. These activities can be divided into three primary interactive functions which include acquisition logistics, in-service support and operational logistics. These functions are described as follows [Ref 4]:

a. Acquisition logistics represents the Navy investment in logistic support resources and services. It is this function which provides the basic corner pillars of operational force readiness and sustainability.

b. In-service support is the distribution of the necessary supplies and equipments, and proper maintenance of weapons and related support systems. This function integrates the mission of the Naval Supply System to provide supplies and services with responsibilities of the Navy maintenance and base operating support.

c. Operational logistics is the allocation of logistic support and service resources to all levels of the operating forces.

2. Organizational responsibilities of the Naval Logistics System

The Chief of Naval Operations (CNO) retains overall responsibility for both supplier and user of logistics in the Navy. [Ref. 4:p. 4-1] Organizational responsibilities of the Naval logistic systems are divided between three separate organizations under the CNO: (1) the Office of the Chief of Naval Operations, (2) the shore establishment consisting of Systems Commands and CONUS shore commands, and (3) operating forces commanders-in-chiefs. [Ref. 3:p. 2-3]

Within the Office of the Chief of Naval Operations, responsibilities are divided between program sponsors, the Deputy Chief of Naval Operations for Logistics (OP-04), the Director of Navy Program Planning, and the Deputy Chief of Naval Operations (Plans, Policy and Operations). Program sponsors are primarily responsible for conducting Planning, Programming and Budgeting System (PPBS) activities and ensuring integration of logistics considerations in the PPBS process. The DCNO for Logistics, OP-04, is the

logistics program sponsor and is responsible for assessing force logistics requirements and developing the Navy acquisition and operational logistic policy. The Director of Navy Program Planning supervises and evaluates policy and is responsible for programming and budgeting of Navy logistics system resources. The DCNO for Plans, Policy and Operations provides strategic planning guidance for mobilization requirements in time of war. [Ref. 4:p. 2-3]

The shore establishment is made up of the System Commands (SYSCOMS) and Manpower, Personnel, Training, Medical and shore commands. There are five systems commands under the CNO: the Naval Air System Command (NAVAIR), the Naval Sea System Command (NAVSEA), the Naval Supply System Command (NAVSUP), the Space and Naval Warfare Command (SPAWAR), and the Naval Facilities Engineering Command (NAVFAC). The SYSCOMS are responsible for developing in-service support logistics policy relative to the Navy Supply System, facilities engineering, and maintenance of activities under their cognizance. The Manpower, Personnel, Training, Medical and shore commands implement logistic programs as directed by the program sponsors. [Ref. 4:p3]

Operating forces, Fleet commanders-in-chief (CINC) and other Navy component commanders are responsible for identifying acquisition and in-service support logistics requirements and forwarding these requirements to their cognizant shore activities. [Ref. 4.p. 7]

B. MANAGEMENT OF NAVY TRANSPORTATION

Overall responsibility for the management of Navy-wide transportation resides with the Chief of Naval Operations. As in the logistics organization, responsibilities for day-to-day management of Navy transportation are shared. The Deputy Chief of Naval Operations (Logistics) OP-04 is responsible for Navy transportation management within the naval operations organization. Under OP-04, the Director of the Material Division (OP-41) controls Navy transportation functions within the Defense Transportation System (DTS). The Director also acts as the program coordinator, issues policy guidance and evaluates transportation services. Also under OP-04, the Director of the Strategic Sealift Division (OP-42) is responsible for the planning, programming and budgeting cycle and is the Navy program sponsor for Military Sealift Command. [Ref. 5:pp. 1-5] Additionally, the Bureau of Military Personnel has the primary responsibility as manager of Navy Passenger Transportation.

The Commander, Navy Supply System Command (NAVSUP), is designated as the manager of Navy Material Transportation. NAVSUP's primary responsibility is to provide effective transportation support at the lowest cost possible. NAVSUP is specifically tasked with recommending policy changes and financial management of servicewide transportation (SWT) which is comprised of First Destination Transportation (FDT) and Second Destination Transportation (SDT) funds. [Ref. 5:p. 5]

III. SHIPPING POLICY

This chapter identifies NAVSUP shipping policy which underscores the shipping methodologies employed in the Navy supply system in general, and the small parcel methodologies in particular. It explores the various stages of NAVSUP shipping policy implementation and also assesses how such policy permeates the various shipping processes affecting the movement of freight.

A. BACKGROUND

NAVSUP is tasked by the CNO to develop and execute transportation policies for the movement of Navy material. A corollary to this task is the development of detailed guidance to shippers of how to execute such policies. As far as the Navy is concerned, however, there is no separate regulation or directive that is specific to the Navy. What the Navy has is a shared ownership of uniform procedures and guidance regarding the movement and management of freight. The Navy shares with the other services and agencies this publication which is commonly known as the Military Traffic Management Regulation (MTMR). For the Navy, the MTMR is designated as NAVSUPINST 4600.70; for the Army, it is AR 55-355; for the Air Force, it is AFM 75-2.

B. NAVSUP SHIPPING POLICY

The broad guidance regarding traffic management is contained in the DoD Directive 4500.9 which states that:

It is DoD policy to procure safe, secure, reliable, and quality commercial transportation services that shall meet DoD requirements at the lowest overall cost. To support this policy, the DoD transportation single managers and the shipper services shall promote a viable commercial transportation network capable of meeting wartime and peacetime transportation requirements. [Ref. 9]

NAVSUP shipping policy is therefore explicit and is so expressed in NAVSUPINST 4600.70. This instruction enforces the general guidance from DoD Directive 4500.9 which dictates that the services shall (1) develop negotiation plans and strategies to ensure short-term and long-term transportation needs are met, (2) develop acceptable standards of service based on objective criteria, and determine carriers qualified to be used by DoD. To achieve the intent of these guidelines, the services, therefore, must work closely with the procurement community in material acquisition to ensure that transportability factors and transportation costs and constraints are considered. Moreover, Navy shippers must take advantage of the benefits and economies to be achieved by consolidating shipments and by adjusting schedules where movement requirements permit. It is also necessary to limit the use of premium methods and modes of transportation to shipments that clearly require such service requirements.

C. NAVSUP SMALL PARCEL SHIPPING POLICY

The overall governing instruction on small parcel shipment is contained in the MTMR where cargo routing authority is specified. NAVSUPINST 4600.70 states:

The transportation officers are authorized to select the mode(s) of commercial transportation, the origin carrier within each mode, and the connecting carrier(s) when it is to the advantage of the Government to name such carrier(s) in the bill of lading ...for shipments of general commodities less than 10,000 pounds. [Ref. 10]

NAVSUP policy on small parcel shipment does not go into anymore detail except where it suggests in Chapter 206 of the MTMR that appropriate carriers, i.e., Federal Express and United Parcel Service, be utilized where they are advantageous to the government.

1. Mode of transportation selection

Whereas DoD Directive 4500.9 generally outlines and tasks the services to choose the means in meeting DoD transportation requirements at the lowest overall cost, the services have translated this into more specific guidance. NAVSUPINST 4600.70 states in paragraph 102003:

The means of transportation selected will be that which will meet DoD requirements satisfactorily at the lowest overall cost from origin to the final destination. [Ref. 10]

The mode of transportation selection for general commodities less than 10,000 pounds is left to the discretion of the installation transportation officer. [Ref. 11:p. c-10]

2. Size and weight limitation

The definition of small parcel shipment is set by the carrier(s). For example, for UPS, small parcel shipment is described as 108 inches in length and girth combined, while the weight of each package is limited to 50 pounds. Additionally, the aggregate weight of all packages from one consignor to one consignee at one location, in one day, must not exceed 100 pounds. For Federal Express, small parcel shipment is described as 108 inches in length and girth combined. The weight of each package is limited to 70 pounds. And the aggregate weight of packages and articles from one consignor to one consignee, at a single location, in one day is limited to 300 pounds. [Ref. 11:p. A-11/12].

For NAVSUP purposes, small parcel shipment is described as having a total cube of 4.2 cubic feet, and the weight of each package is not to exceed 70 pounds.

D. ROUTING OF FREIGHT

For small parcels shipped overseas, the shipment decision logic primarily uses the weight, cube and requisition priority criteria and recommends a mode of shipment to be used consistent with those criteria as if the shipment destination is in CONUS. The reason for this is that all fragmented shipments, such as small parcel items for overseas, are sent to consolidation points. In the case of overseas shipments destined to the Pacific theater and Southeast Asia, the Military Ocean Terminal Bay Area in Oakland is the consolidation point for surface shipments, and Travis Air Force Base is the consolidation point for air eligible shipments. Some of the small parcel shipments also go by the U. S. Postal Service whereby shipments are sent through the APO/FPO pipeline. For shipments destined to the Atlantic theater and the Mediterranean area, the consolidation point is the Military Ocean Terminal in Bayonne, New Jersey.

Routing and selecting the mode of shipment to be used to ship small parcel shipments to their CONUS final destination or to their designated consolidation points for overseas shipments depend significantly on the priority of the shipment. As a general rule, all Issue Priority Group (IPG) I shipments are done on a free flow basis. This means that as the IPG I shipment has completed the packing process, it does not wait for more freight to build up before it is shipped out. Only the IPG II and III requisitions are

afforded consolidation considerations. This is done to comply with the UMMIPS¹ [Ref. 11] time standards.

E. SHIPPING NETWORK

NSC San Diego's ability to move freight in compliance with UMMIPS standards is dependent upon the transportation network that it utilizes. The network comprises the various arrangements with the transportation industry based on what is economically available in the commercial sector. The following are descriptions of the frequently used methods of freight routing and modes of shipments:

1. QUICKTRANS

QUICKTRANS is a dedicated air mode that uses chartered commercial air carriers which operate along established lines of operating authority. Freight that moves through the QUICKTRANS system is fed through the air consolidation points either through CONTRUCK (discussed below) or other appropriate mode of transportation.

2. CONTRUCK

CONTRUCK stands for Contract Truck Carriers which are motor carriers that transport freight between points of their line-haul authority. Freight that moves through this arrangement can either be on a truckload or less-than-truckload basis.

¹ UMMIPS stands for Uniform Material Movement and Issue Priority System. UMMIPS prescribes guidance for the proper ranking of material requirements, considering mission importance of the requiring activity and the urgency of need for the material, and provides incremental time standards for requisition processing and material movement. [Ref. 11]

3. Standing Route Orders

Standing Route Orders (SRO) is a program utilized by local Installation Transportation Officers (ITO) to move freight. This program is designed to help meet the repetitive freight movement generated by the Navy shipping activities. Truckload and less-than-truckload shipments move through this program. Carriers that do business with the Navy shipping points through this arrangement accept freight on a demand basis. These carriers have freight rate tenders to operate between designated points. The carriers that serve under the SRO program have proven track records. They are reliable, responsive, responsible, and low-cost carriers. The carriers on the SRO list are screened and selected by the Military Traffic Management Command (MTMC). Updates of the SRO list are also published by MTMC.

4. Guaranteed Traffic

The guaranteed traffic program is administered by MTMC. Carriers that are selected to move freight for the Navy under the guaranteed traffic program are selected based on a negotiated rate in addition to standard factors such as reliability, responsiveness, responsibility, and operating authority and tenders. Under the guaranteed traffic program, the transportation officers at field installations and activities furnish MTMC with information such as the class of commodities and the approximate volume of freight that is anticipated to be moved between activities within a certain geographical area for a certain period. These factors are guaranteed by the government to exist or to occur as conditions for the guaranteed program. It is this guarantee that gets carriers interested in participating in the program. The rates are negotiated between MTMC and

the carriers. The negotiated rate is usually advantageous to the government compared with tariff rates.

5. Freight Forwarders

Freight forwarders are carriers that collect small shipments from shippers, consolidate the small shipments and use an aggregated line-haul mode to transport these consolidated shipments to a destination where the freight forwarder delivers the shipment to the consignee. Federal Express, United Parcel Service, and Roadway Package Service fall under this category. Although their arrangement with the government is similar to the SRO program, freight forwarders are different in the sense that their tenders are set up differently. They generally cater to small parcel shipments and consolidate them. The consolidated freight is then moved as a full load or truckload to its destination where it is then broken down for delivery. Freight forwarders do have CONUS and overseas networks, but Navy shippers, in general, have been prohibited from using the overseas leg of the freight forwarders because of customs delays at destination.

6. U. S. Postal Service

A significant amount of small parcel items moves via the postal system for both CONUS and overseas destinations. The overseas destinations operate under the APO/FPO concept. The APO/FPO destinations; i.e., APOs/FPOs San Francisco, Seattle, Miami and New York, are consolidation points for mailable small parcel items. The small items that are shipped via the postal service are almost all IPGs II and III.

7. Organic Transportation

The organic transportation system consists of government-owned transportation assets to move freight between the shipper and the consignee. Examples of organic government transportation assets are straddle trucks and open flatbed trucks. Organic assets are normally used for local delivery. In the case of NSC San Diego, use of organic assets is significant because 84 percent of materials issued from the supply center is for local customers such as the fleet activities on the waterfront.

There are 33 modes of shipments available to NSC San Diego to move freight and are listed in Appendix A. These modes are potential modes by which small parcels can be shipped. Use of any one of these modes is significantly dependent on the equipment availability of the carrier at the time of demand and also the overall cost of a contemplated freight shipment. The modes which are usually used to ship small parcel items are modes B (motor, less than truckload), G (surface parcel post), H (air parcel post), and 5 (surface small package carrier).

IV. NISTARS AND NAVADS AT NSC SAN DIEGO

This chapter outlines NISTARS and NAVADS systems and operations. It also discusses the interface between the two systems. This is followed by a discussion of NSC San Diego small parcel policy and changes which can occur in the mode of shipment recommended by NISTARS and NAVADS. The last section of this chapter deals with the NAVADS mode of shipment logic flow.

A. NISTARS

NISTARS is a storage, tracking and receiving system that provides state-of-the-art process control of physical distribution activities at the Naval Supply Centers in San Diego, Oakland, and Norfolk. The automated part of NISTARS at San Diego is a computer-controlled 235,000 square-foot distribution processing facility. Material is held in 40-foot high storage racks and, depending on the size and weight of the item, is stored in bins, directly on the racks, or on pallets. Small fast-moving binnable items are stored and retrieved by robotic mini-load systems in the ministacker complex. Slower moving binnable items, rackable items, and palletized items are stored and retrieved by people onboard specially configured manned storage and retrieval machines. Outside of the racks, movement of material throughout the warehouse is done by conveyors or automated guided vehicles.

NISTARS computer software is structured as a transaction processing system. It is driven by transactions that must be responded to in batch system process as will be

explained later in subsection D. The NISTARS computer hardware consists of a number of control processors, mirrored random access disc files, and tape drives. The computer system, hardware and software, is collectively identified as the NISTARS Central Controller. Intelligent Remote Terminals (IRTs) are located at each warehouse workstation. The workstation IRT provides a video display to communicate with and guide the warehouse worker. Information transfers between IRTs and the Central Controller computer provide rapid feedback of information to integrate the processes of receiving, stowing, issuing, inventorying, consolidating and shipment packing. [Ref. 2]

B. NAVADS

NAVADS is an automated management control, planning and documentation system. It is designed to facilitate shipment unit consolidation and multi-modal movement of material issued and transhipped by the Naval Supply Centers. The system provides the capability to make advanced decisions relative to modal selection and shipment consolidation, and generate transportation documentation such as Government Bills of Lading, Transportation Control and Movement Documents, and shipping labels. Additionally, selected management information reports are generated.

NAVADS has three subsystems: (1) the Basic Data Package Subsystem, (2) the Management Control Subsystem, and (3) the Automated Documentation Subsystem. The Basic Data Package Subsystem, usually called Subsystem I, is designed to mechanize many previously manual shipment functions. This subsystem accepts inputs from various sources, including other activities such as the Defense Logistic Service Center, Defense

Automatic Addressing System Office, and most ADP media, including card, tape, disk and CRT. The Management Control Subsystem, usually called Subsystem II, is designed to provide the user with the capability to control routine workload and to expedite high priority workload by accessing applicable data from Subsystem I and using this data to determine the mode of shipment. The Automated Documentation Subsystem, usually called Subsystem III, is designed to provide proof of shipment. The Automated Documentation Subsystem tracks material through packing, staging, and shipping to provide constant visibility of all issued stock.

C. NSC SAN DIEGO SMALL PARCEL POLICY

The criteria implemented at NSC San Diego for small parcel shipment are determined by the factors loaded in NAVADS System Constants Area File. It is this program file against which the automated processes compare the requisition to determine the mode of shipment. These criteria are applied automatically in the shipment logic when materials are issued from the supply center.

There are cases when certain shipments are not shipped as recommended by NAVADS. When this occurs, the criteria used by NSC San Diego to determine the mode of shipment is basically determined by in-house direction (see Appendix B), and restrictions imposed by the individual carrier tender, and the availability of an appropriate carrier.

NAVADS does not recognize repairable items and therefore it recommends a mode of shipment based only on factors loaded in the NAVADS System Constants Area File.

When this occurs, a shipment is pulled out after the issue process and sent to Code 400 for further evaluation. This process may result in either a mode of shipment change or no mode of shipment change at all.

D. UADPS-SP/NAVADS INTERFACE

The programs used in NAVADS are designed to work in tandem with the UADPS-SP computer system employed at NSCs along with NISTARS. The Automated Documentation Subsystem operates by accepting input data from Subsystem II, from NISTARS and from CRTs within the Subsystem III network. As transactions are processed through the network, records are updated on-line. The outputs consist of shipping documents, management reports, and transactions produced in support of the required interface with other systems. [Ref. 7:Vol. III] Subsystem II receives requisition records from UADPS-SP. If the requisition is received from one of the real-time UADPS-SP issue programs, it would be processed through NAVADS as a real-time issue. If the requisition is received via one of the UADPS-SP batch issue programs, the requisition would either be passed back to real-time, processed in the next cycle, or written to the NAVADS Issue File (NIF) for consolidation. This decision is accomplished by activity options loaded into program control cards. Issues are released from the NIF by input of a program card or a CRT input. [Ref. 7:Vol. II] Subsystem III, on the other hand, receives cancellations, requisitions and shipment unit records from Subsystem II. Subsystem II also receives updated transactions from NISTARS. Once records are established on the Perkin Elmer mini-computer, requisitions and shipment units are

processed and shipping documentations are prepared by transactions which are initiated by CRT input. [Ref. 7:Vol III]

NAVADS, as a management control, planning and documentation system, is the focal element in the determination of the mode of shipment for all requisitions processed by NISTARS at NSC San Diego. NAVADS programs use information contained in the NAVADS Name and Address File (NNF), the NAVADS Freight/Hazardous Classification File (NFF), System Constants Area tables and the Program Control Cards to determine the best mode of shipment to be used for a particular shipment.

E. MODE OF SHIPMENT CHANGES

The mode of shipment is the mode of transportation by which a particular shipment is transported from the shipment origin to its destination. An example of shipment mode as shown in Appendix A is mode B: motor, less than truckload. This means that the transportation mode dictated by the shipment is the use of a motor carrier and the shipment is tendered as less-than-truckload. Mode of shipment changes occur when the NAVADS-recommended mode of shipment, mode B, is changed to another mode such as mode G, which is surface parcel post.

As general guidance, mode of shipment changes are authorized only when such change is advantageous to the government. Reasons such as "to meet operational commitment" or "urgently required" are no longer acceptable. Previously, such phraseology could suffice to get urgently needed material shipped via air or priority lift and also to get an expedited movement order. Recently, there has been a shift of

mentality because of perceived inefficiencies in the system. The Navy Material Transportation Office (NAVMTO), which is the clearance authority for Navy shippers, has tightened up Navy shipment parameters.

When an item is issued and leaves the issue process, a DD Form 1348-1 is produced for that item. In that shipping document, a mode of shipment is already printed as decided from NAVADS shipment decision logic. Exhibit IV-1 illustrates this by the "Mode: G surface parcel post" at the bottom left corner of the document. As the shipment is moved to packing, the material is packed and shipped according to the mode of shipment coded on the shipping document.

There are instances when a shipment is not packed as per the shipping document generated by NAVADS. For instance, if a material is repairable, if the requisition has a project code of 999, or if the destination is overseas, the packers are alerted by these factors that cause the requisition to be sent to Code 400 for further evaluation. Additionally, not packing the item for the mode as recommended by NAVADS is also done for other reasons such as: (1) the material needs a special packing requirement, (2) the shipment is a repairable item which must be shipped via traceable means, (3) the shipment is a CASREP item, (4) special request from higher authority and/or the customer, and (5) NAVADS failing to automatically post proof of shipment.

NSC San Diego receives a large number of requisitions per month as depicted in Exhibit IV-2. Exhibit IV-2 also illustrates the number of small parcels shipped, the number of small parcel shipments deferred to Code 400 and the number of requisitions for which Code 400 changed the mode of shipment.

REQUISITIONS

NSC SAN DIEGO

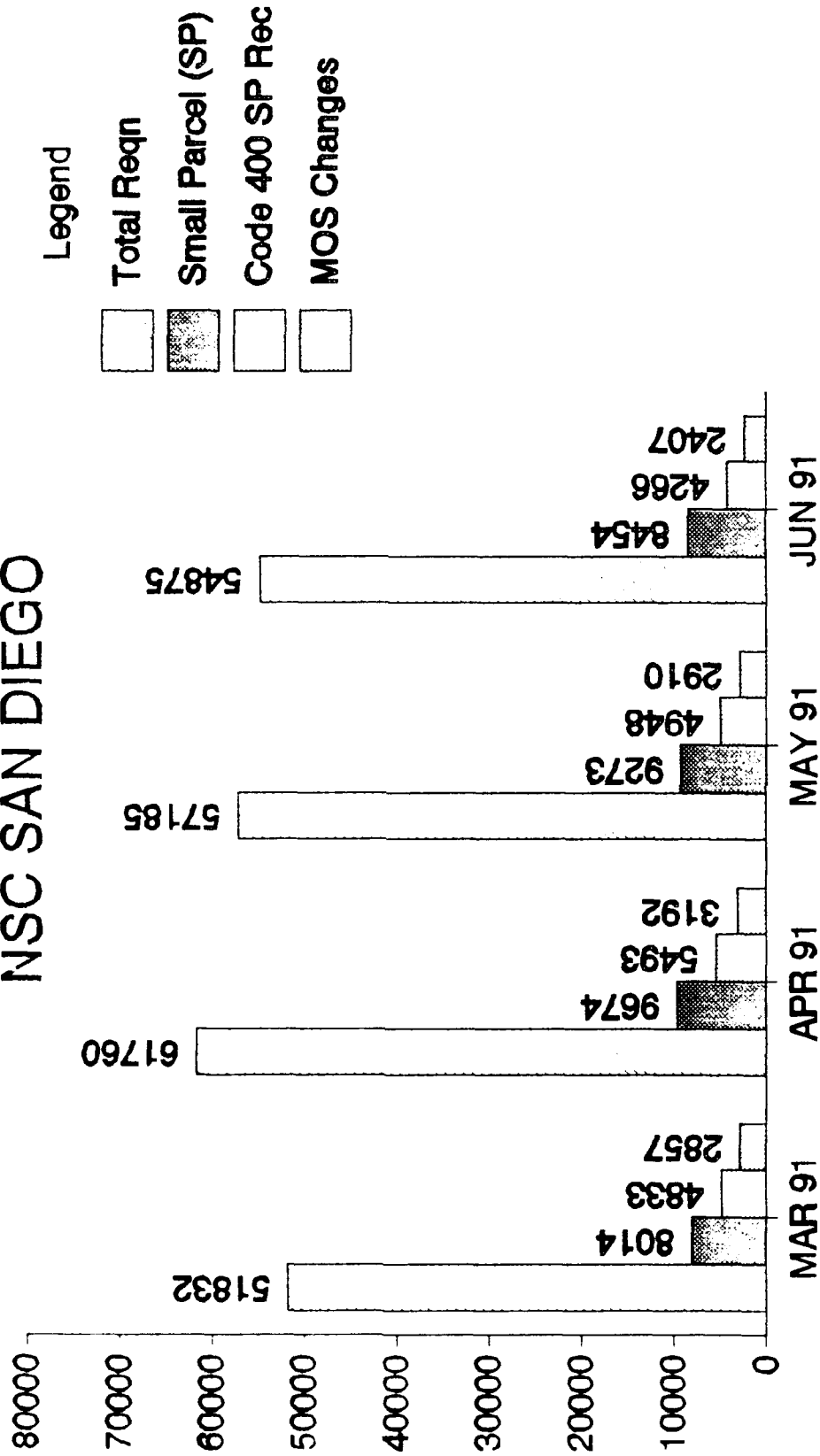

NSC San Diego Code 400 uses Appendix A in determining the mode of shipment for an item. In addition, Code 400 looks at the following factors in determining which mode of shipment is appropriate for the particular requisition in question:

1. Current location of the requisitioner. The NAVADS-recommended mode of shipment may be affected when the current location of the requisitioner is not where NAVADS thinks the unit is located. This is especially true when units deploy or leave port to conduct exercises for an extended period of time. Update of a unit's location, which is done by the unit itself through NAVMTO, does not happen instantaneously. Material requirements are submitted to the supply center routinely and the shipments of these requisitioned materials can happen before the unit locator file is updated in the supply system.

2. Special guidance from higher authority. Requisitions may be intercepted anywhere in NISTARS. A requisition can be intercepted prior to issue or after issue has been made and the material is being packed for shipment. The mode of shipment changes that occur in this case happen when the material has been issued or pulled from the storage bin and already on its way to be packed. At this stage, shipping documents have been cut by NISTARS/NAVADS processes. In most cases, the mode of shipment is affected here because special guidance from the interested party can usually mean shipping the material by the mode desired by the interested party. Messages sent to Code 400 usually request changes in the NAVADS recommended mode of shipment.

3. Most economical mode of shipment considering the urgency of need of the material. When the priority of the requisition is upgraded by the requesting activity, the

priority upgrade usually means changing also the mode of shipment to meet the need of the requesting activity. This can also happen while the requisition is still being packed for shipment.

4. Special tracking requirements of the item as required by higher authority; i.e., repairable items must be shipped via traceable means [Ref. 9]. There are cases where the NAVADS does not recognize a repairable item and, therefore, it recommends a mode of shipment based on factors loaded in the NAVADS System Constant Area File. When this occurs, a requisition is pulled out after the issue process and sent to Code 400 for further evaluation. This process may either result in a mode of shipment or no mode of shipment change at all.

F. NAVADS MODE OF SHIPMENT LOGIC FLOW

The process of NAVADS selecting the correct mode of shipment has its significance in various stages of the shipping process. On the one hand, NISTARS automatically posts all proofs of shipment for various modes such as mode H (air parcel post), Mode G (surface parcel post), and Mode 5 (surface small package carriers), when acknowledgement during the picking process has been transmitted or when acknowledgement has been transmitted that packing for the item has been completed. At this point of the shipping process, operator intervention is required if other than the recommended mode of shipment is going to be used. When this mode change occurs, the customer can receive shipping status other than what is actually used to transport the

material. On the other hand, when NISTARS does not automatically post the proof of shipment, the requisition remains in an open BA² status.

The requisitions that do not automatically post proofs of shipment are sent to Code 400 for further determination. Any requisition that does not automatically post proof of shipment requires human intervention or exception processing. Although the requisitions sent to Code 400 eventually get shipped within the UMMIPS time standard, the requisition status at NISTARS remains an open BA until Code 400 has manually input the correct mode of shipment. Due to heavy workload, Code 400 sometimes experiences delay in posting proofs of shipments. This is why the requisition remains an open BA at NISTARS while the correct mode of shipment is waiting to be fed into the system. This also explains why customers sometimes receive material even when status cards indicate that they haven't yet. An interesting problem can occur when a customer requests an updated status of its requisition. Because NSC San Diego customer service provides status obtained from NISTARS on-line data, the customer gets a BA status even if the requisition actually has been shipped. If the material requisitioned is urgently needed, the customer can request an off-line issue and shipment of the same material. As a result, double shipment occurs.

Exhibit IV-3 is a flowchart of the logic NAVADS follows when recommending a mode. It illustrates the various conditions a shipment transaction passes through to arrive

² BA status means that the item requisitioned is being processed for issue and shipment. [Ref. 13] NSC San Diego has defined BA status to mean that NISTARS recognizes the item as carried at the supply center and that there is sufficient quantity in stock to fill the requirement

Exhibit IV - 3

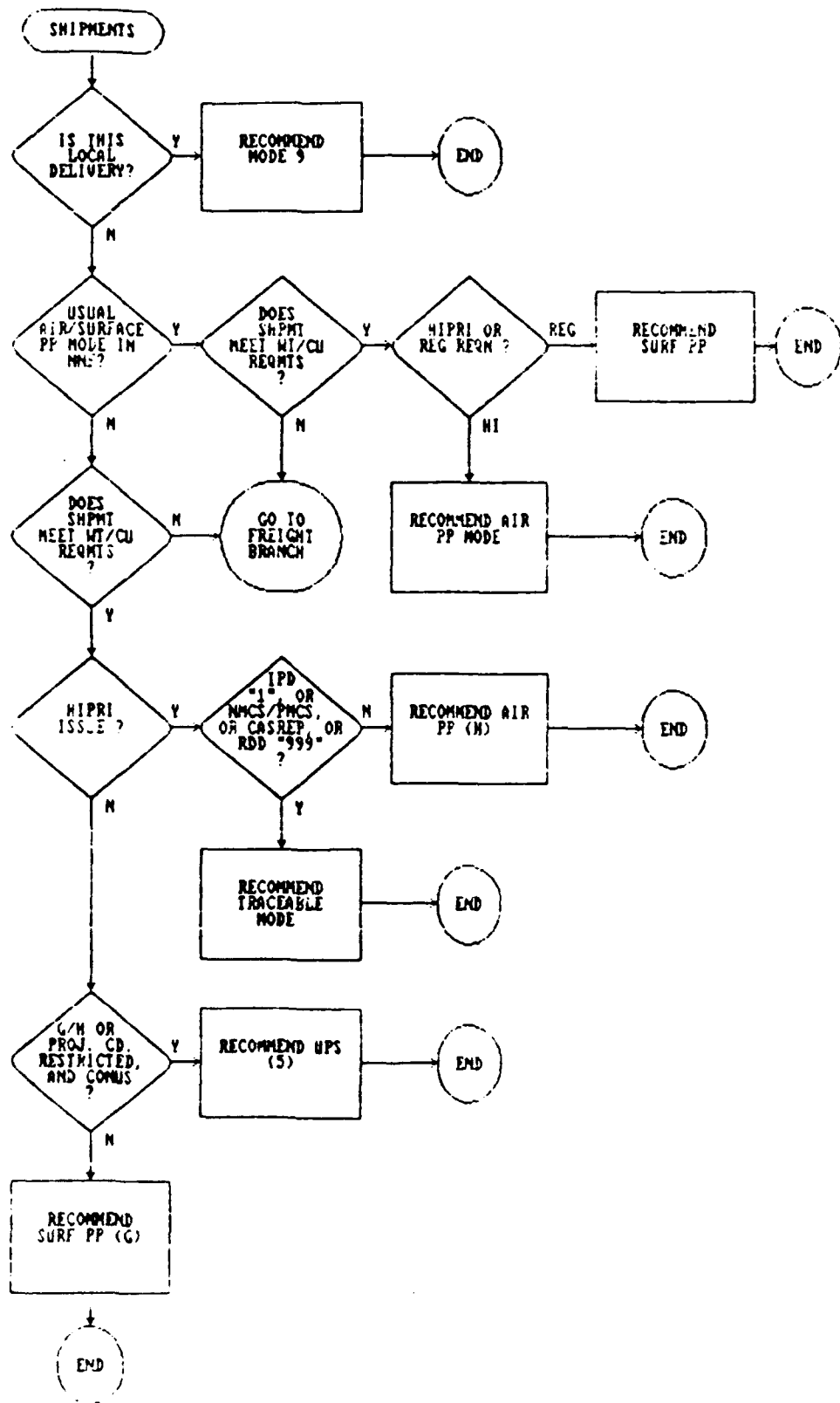

at a recommended mode. The various information coded on the requisition documents are bounced against this decision logic until a fit is made whereby a mode is assigned. For illustration, Exhibit IV-4 and other shipping documents were reviewed against the flowchart to determine if the program logic and NAVADS file were consistent. As illustrated, Exhibit VI-4 contains the surface mode which is motor, less than truckload (Mode B) as the recommended mode of shipment (see lower left-hand corner box). However, the actual mode of shipment used was surface parcel post (Mode G) as annotated at the lower right hand side of the document in the block "Shipped By". The annotation 2/G is a local code used by Code 400. The 2 means the shipment is under IPG 2, and G, surface parcel post, is the shipment mode. The mode of shipment in this case was changed because the material is under IPG II.

In order to determine whether NAVADS consistently translates the information from the requisition as would be expected, query retrievals were made to the NAVADS Freight/Hazardous Classification File. Exhibit IV-5 is presented for illustration. As indicated in the weight and cube blocks, the shipment weighs four pounds and has a cube of one cubic foot. The response from the NAVADS Freight/Hazardous Classification File showed the weight and cube information that makes the shipment eligible for air parcel post. The queries were made also to the NAVADS Name and Address File. In comparison, the NAVADS Name and Address File retrieval, Exhibit IV-6, does contain the air small parcel or surface parcel modes loaded for the particular requisition in Exhibit IV-4. The bottom left corner of the exhibit shows that air small parcel mode is loaded.

1. TOTAL PRICE DOLLARS 2. SHIP FROM MOD244 MSC SAN DIEGO SAN DIEGO, CA 92132 3. SHIP TO N20122 4. M/F USS KANSAS CITY AOR 3 5. DOC DATE 1148 6. INVOICE NO 100120 7. PART DATE Q 8. TYP CARGO 29 U 9. TO DIV REC'D 001 10. UNIT WEIGHT 11. UNIT CU 12. UNIT CU 13. UNIT CU 14. UNIT CU 15. ST 16. FREIGHT CLASSIFICATION HOSE, RUBBER, REINFORCED W FABRIC 17. ITEM NOMENCLATURE HOSE ASSEMB 18. TV CONT 19. NO CONT 20. TARI WT 21. TARI CU 22. RECEIVED BY 23. DATE RECEIVED 24. RECEIVED BY 25. RECEIVED BY 26. RECEIVED BY 27. ADDITIONAL DATA 28. RECEIVED BY 29. RECEIVED BY 30. RECEIVED BY 31. RECEIVED BY 32. RECEIVED BY 33. RECEIVED BY 34. RECEIVED BY 35. RECEIVED BY 36. RECEIVED BY 37. RECEIVED BY 38. RECEIVED BY 39. RECEIVED BY 40. RECEIVED BY 41. RECEIVED BY 42. RECEIVED BY 43. RECEIVED BY 44. RECEIVED BY 45. RECEIVED BY 46. RECEIVED BY 47. RECEIVED BY 48. RECEIVED BY 49. RECEIVED BY 50. RECEIVED BY 51. RECEIVED BY 52. RECEIVED BY 53. RECEIVED BY 54. RECEIVED BY 55. RECEIVED BY 56. RECEIVED BY 57. RECEIVED BY 58. RECEIVED BY 59. RECEIVED BY 60. RECEIVED BY 61. RECEIVED BY 62. RECEIVED BY 63. RECEIVED BY 64. RECEIVED BY 65. RECEIVED BY 66. RECEIVED BY 67. RECEIVED BY 68. RECEIVED BY 69. RECEIVED BY 70. RECEIVED BY 71. RECEIVED BY 72. RECEIVED BY 73. RECEIVED BY 74. RECEIVED BY 75. RECEIVED BY 76. RECEIVED BY 77. RECEIVED BY 78. RECEIVED BY 79. RECEIVED BY 80. RECEIVED BY 81. RECEIVED BY 82. RECEIVED BY 83. RECEIVED BY 84. RECEIVED BY 85. RECEIVED BY 86. RECEIVED BY 87. RECEIVED BY 88. RECEIVED BY 89. RECEIVED BY 90. RECEIVED BY 91. RECEIVED BY 92. RECEIVED BY 93. RECEIVED BY 94. RECEIVED BY 95. RECEIVED BY 96. RECEIVED BY 97. RECEIVED BY 98. RECEIVED BY 99. RECEIVED BY 100. RECEIVED BY											
A41NDZS EA0001 151HRLAVV IRAK105 NDN32AAJM0002550 N20122 1134 AY46 4720 01 237 9485 WK NDZ EA 00001 A 1R 0002550 PRINT DT: 01148 06:107 SERIALIZED RESTART NR: 00071 ORIG NSN: APDE: SUU APOD: HIK PARCEL POST PACK LOC: 9999 SHIP LOC: 0001 MODE: B LTL TRAILER DATA: TAC: N101 ACDN: BZ PHINC: GE0 AREA: AAC9 UNCLASSIFIED 27 ADDITIONAL DATA POS POS 28 RECEIVED BY 29 RECEIVED BY 30 RECEIVED BY 31 RECEIVED BY 32 RECEIVED BY 33 RECEIVED BY 34 RECEIVED BY 35 RECEIVED BY 36 RECEIVED BY 37 RECEIVED BY 38 RECEIVED BY 39 RECEIVED BY 40 RECEIVED BY 41 RECEIVED BY 42 RECEIVED BY 43 RECEIVED BY 44 RECEIVED BY 45 RECEIVED BY 46 RECEIVED BY 47 RECEIVED BY 48 RECEIVED BY 49 RECEIVED BY 50 RECEIVED BY 51 RECEIVED BY 52 RECEIVED BY 53 RECEIVED BY 54 RECEIVED BY 55 RECEIVED BY 56 RECEIVED BY 57 RECEIVED BY 58 RECEIVED BY 59 RECEIVED BY 60 RECEIVED BY 61 RECEIVED BY 62 RECEIVED BY 63 RECEIVED BY 64 RECEIVED BY 65 RECEIVED BY 66 RECEIVED BY 67 RECEIVED BY 68 RECEIVED BY 69 RECEIVED BY 70 RECEIVED BY 71 RECEIVED BY 72 RECEIVED BY 73 RECEIVED BY 74 RECEIVED BY 75 RECEIVED BY 76 RECEIVED BY 77 RECEIVED BY 78 RECEIVED BY 79 RECEIVED BY 80 RECEIVED BY 81 RECEIVED BY 82 RECEIVED BY 83 RECEIVED BY 84 RECEIVED BY 85 RECEIVED BY 86 RECEIVED BY 87 RECEIVED BY 88 RECEIVED BY 89 RECEIVED BY 90 RECEIVED BY 91 RECEIVED BY 92 RECEIVED BY 93 RECEIVED BY 94 RECEIVED BY 95 RECEIVED BY 96 RECEIVED BY 97 RECEIVED BY 98 RECEIVED BY 99 RECEIVED BY 100 RECEIVED BY											
1. TOTAL PRICE DOLLARS 2. SHIP FROM MOD244 MSC SAN DIEGO SAN DIEGO, CA 92132 3. SHIP TO N20122 4. M/F USS KANSAS CITY AOR 3 5. DOC DATE 1148 6. INVOICE NO 100120 7. PART DATE Q 8. TYP CARGO 29 U 9. TO DIV REC'D 001 10. UNIT WEIGHT 11. UNIT CU 12. UNIT CU 13. UNIT CU 14. UNIT CU 15. ST 16. FREIGHT CLASSIFICATION HOSE, RUBBER, REINFORCED W FABRIC 17. ITEM NOMENCLATURE HOSE ASSEMB 18. TV CONT 19. NO CONT 20. TARI WT 21. TARI CU 22. RECEIVED BY 23. DATE RECEIVED 24. RECEIVED BY 25. RECEIVED BY 26. RECEIVED BY 27. ADDITIONAL DATA 28. RECEIVED BY 29. RECEIVED BY 30. RECEIVED BY 31. RECEIVED BY 32. RECEIVED BY 33. RECEIVED BY 34. RECEIVED BY 35. RECEIVED BY 36. RECEIVED BY 37. RECEIVED BY 38. RECEIVED BY 39. RECEIVED BY 40. RECEIVED BY 41. RECEIVED BY 42. RECEIVED BY 43. RECEIVED BY 44. RECEIVED BY 45. RECEIVED BY 46. RECEIVED BY 47. RECEIVED BY 48. RECEIVED BY 49. RECEIVED BY 50. RECEIVED BY 51. RECEIVED BY 52. RECEIVED BY 53. RECEIVED BY 54. RECEIVED BY 55. RECEIVED BY 56. RECEIVED BY 57. RECEIVED BY 58. RECEIVED BY 59. RECEIVED BY 60. RECEIVED BY 61. RECEIVED BY 62. RECEIVED BY 63. RECEIVED BY 64. RECEIVED BY 65. RECEIVED BY 66. RECEIVED BY 67. RECEIVED BY 68. RECEIVED BY 69. RECEIVED BY 70. RECEIVED BY 71. RECEIVED BY 72. RECEIVED BY 73. RECEIVED BY 74. RECEIVED BY 75. RECEIVED BY 76. RECEIVED BY 77. RECEIVED BY 78. RECEIVED BY 79. RECEIVED BY 80. RECEIVED BY 81. RECEIVED BY 82. RECEIVED BY 83. RECEIVED BY 84. RECEIVED BY 85. RECEIVED BY 86. RECEIVED BY 87. RECEIVED BY 88. RECEIVED BY 89. RECEIVED BY 90. RECEIVED BY 91. RECEIVED BY 92. RECEIVED BY 93. RECEIVED BY 94. RECEIVED BY 95. RECEIVED BY 96. RECEIVED BY 97. RECEIVED BY 98. RECEIVED BY 99. RECEIVED BY 100. RECEIVED BY											



REOSCN
 85684731
 LINE 001 OF 001

2

ISSUED BY
 156 PMS
 SHIPPED BY
 2/16

F-LOC 688-161-20-B
 NSN 4720-01-237-9485 WK
 QTY 00001 UJ EA CC A
 SU SEN 85684731

MARK FOR
 N20122
 DIMENSIONS

26 RIC 4-8
 25 RECEIVED BY
 24 RECEIVED BY
 23 RECEIVED BY
 22 RECEIVED BY
 21 RECEIVED BY
 20 RECEIVED BY
 19 RECEIVED BY
 18 RECEIVED BY
 17 RECEIVED BY
 16 RECEIVED BY
 15 RECEIVED BY
 14 RECEIVED BY
 13 RECEIVED BY
 12 RECEIVED BY
 11 RECEIVED BY
 10 RECEIVED BY
 9 RECEIVED BY
 8 RECEIVED BY
 7 RECEIVED BY
 6 RECEIVED BY
 5 RECEIVED BY
 4 RECEIVED BY
 3 RECEIVED BY
 2 RECEIVED BY
 1 RECEIVED BY

Exhibit IV-5

NAVADS NFF FREIGHT DATA UPDATE/RETRIEVAL

KWH - XV9 XWH NIIN 012379485 FSC 4720

FUNCTION

FREIGHT DESCRIPTION HOSE, RUBBER, REINFORCED NOI

NMFC CODE 133390 WEIGHT 000004 CUBE 000001

SUBMITTING ACTY INTEGRITY CODE NMFC SUB ITEM NO. Z

UNFM FRT CLS HZRD CARGO CD LTL CODE W

AIR DIM CODE A AIR COM/SP HD VZ WATER COM CODE 592

TYPE CARGO CODE Z SPEC HANDLING 9 OVERSIZE DIM IND

EXCEPTION RESPONSES

Exhibit IV-6

NAVADS NNF ALL DATA UPDATE/ RETRIEVAL

XV2 - ZE1 - XV1 XV2 SERVICE/UIC N20122 FUNCTION LAST ACCESS 9212
TAC 1 OR TAC M ADDRESS 5 LINES TYPE 1 USS KANSAS CITY (AOR-3)
FPO SAN FRANCISCO 96601

TAC 2 OR TAC 3 ADDRESS 5 LINES TYPE 2 USS KANSAS CITY (AOR-3)
FPO SAN FRANCISCO 96601

USUAL AIR H USUAL SURFACE G CONUS GEOG AREA K CON SUB-AREA KT1
APOE SUU APOD WAM WPOE 3KD WPOD TA2

STATE CODE SPLC GBLOC SHPTO/BBPT
PP ZONE 7 MODE RESTRICT SPEC INST IND UPS ZONE

LC CODE LD INSTRUCTIONS
AIR SMALL PARCEL MODE SURFACE SMALL PARCEL MODE
EXCEPTION RESPONSES

--XMT--

MESSAGE SENT

However, for the illustrated DD Form 1348-1 in Exhibit IV-4, when following the program logic in the flowchart, NAVADS recommends surface parcel post (Mode G).

NAVADS inconsistency in recommending the proper mode is partly to blame for NISTARS high rate of requisitions not automatically posting proofs of shipment. The rate of requisitions not having proofs of shipment automatically posted is determined from the total number of small parcels shipped by NSC San Diego divided by the number of small parcel shipments which were to sent Code 400 for further determination. Many of the requisitions sent to Code 400 have retained their NAVADS-recommended mode of shipment, but as previously illustrated in Exhibit IV-2, the mode-of-shipment changes are about 4.9 percent of the total requisitions processed by NSC San Diego.

The above analysis suggests a review of information loaded in the System Constants Area File is needed to ensure that correct information and parameters are loaded and properly defined. It is also suspected that the non-loading of Modes G, H, U, and B in the NAVADS Name and Address File for all activities (CONUS and overseas) may be the problem. As a possible solution, it appears that loading the NNF with Modes G, H, U, and B with further distinction of ships in port, ships deployed, local customers and overseas customers can minimize the mode of shipment inconsistencies.

V. ANALYSIS OF SMALL PARCEL SHIPMENT AT NSC SAN DIEGO

This chapter analyzes a sample of small parcel shipments at NSC San Diego and shows how cost may be avoided by judicious manual changes in shipping mode.

A. NSC SAN DIEGO MODE OF SHIPMENT PROFILE

As shown in Exhibit V-1, NSC San Diego ships the majority of its freight locally. About 84 percent of all material issued from the supply center is delivered locally to allot units on the waterfront and neighboring shore activities by way of organic equipments. This is because NSC San Diego's NISTARS facility, which holds the majority of its inventory, is located on the waterfront. The remaining 16 percent of freight is divided into various other modes, including parcel post.

B. COST OF TRANSPORTATION AS DETERMINED BY NAVADS

Appendix C lists 328 requisitions sampled from DD Form 1348-1's sent to Code 400 between 01 March and 30 June 1991. In order to get a fair sample of the population of requisitions sent to Code 400, it was necessary to preserve the principle of randomness in the sample selection procedure. Because it was unworkable to list all the requisitions (about 19500), a sampling procedure was employed. Since the DD Form 1348-1's were batched and separated by the week they were processed, it was manageable to set up a procedure to pick requisitions at random. In fact, the documents were stored in bundles. Approximately two bundles comprised the requisitions processed in a particular week.

MODE DISTRIBUTION

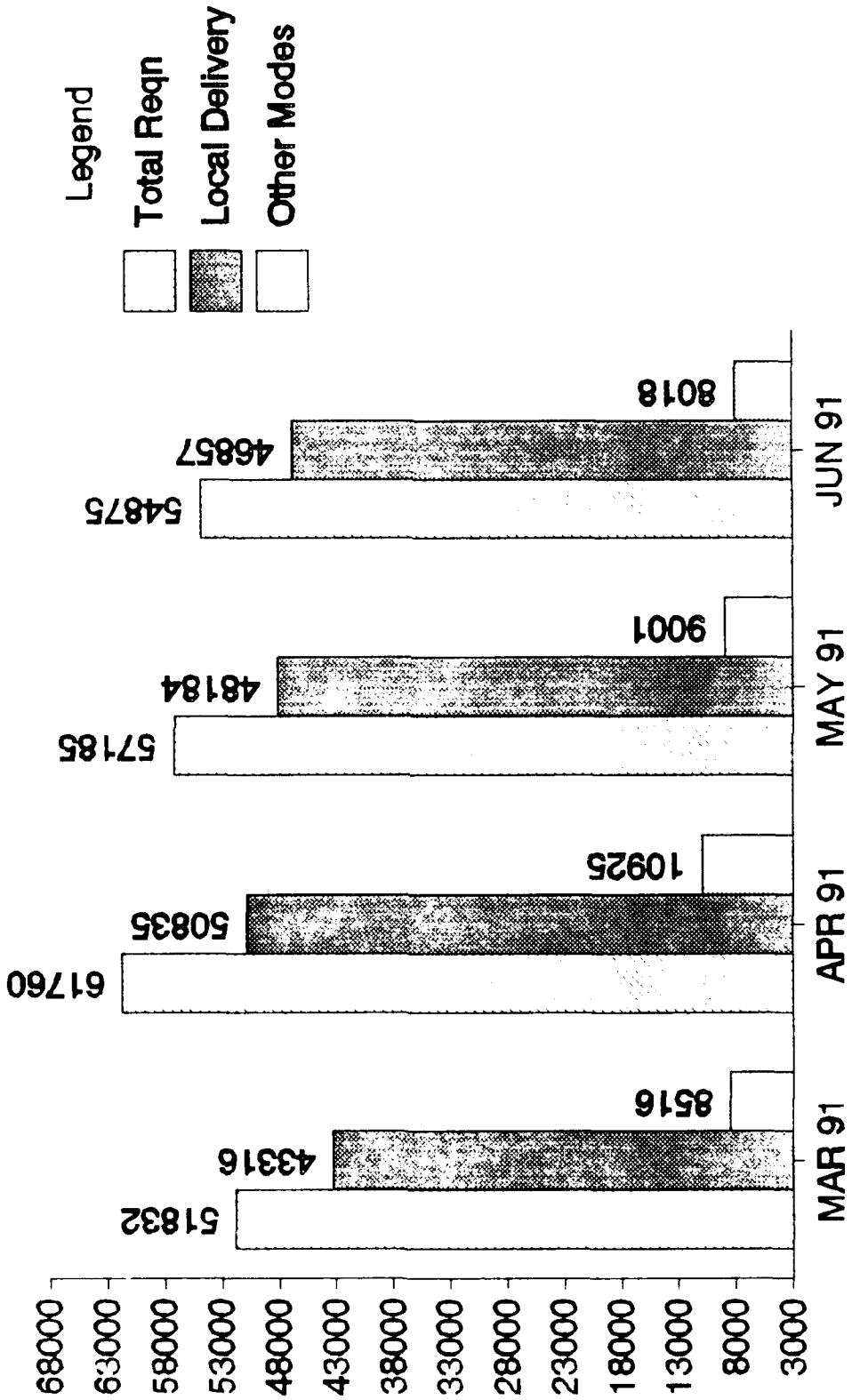

There were 41 bundles covering the time period examined; each bundle had an average of 482 requisitions in it. Each bundle was neither arranged in any particular order or sequence, nor was there any attempt made to do so. The only evident arrangement, if it can be called at that, is that they were separated by the week during which they were processed by Code 400. From each bundle, eight documents were picked. The picking started with the 45th document in each bundle. The subsequent documents were picked at an interval of 44 documents until eight documents were picked from the bundle. This procedure was repeated for each of the 41 bundles, yielding 328 sampled documents.

A discussion of the format of Appendix C is useful here (see headings on the first page of Appendix C). The first three blocks comprise the requisition numbers. Blocks 4, 5, and 6 are the number of units, weight in pounds and cube in cubic feet, respectively. Block 7 is the NAVADS-recommended mode of shipment for the corresponding requisition. Block 8 is the actual mode of shipment used for the corresponding requisition. Block 9 is the Standard Point Location Code (SPLC) for the destination of the requisition. The originating SPLC is 889593290, a specific code that designates the NSC San Diego Annex. Block 10 is the issue priority group to which that particular requisition is assigned. Block 11 is the total cost per pound to ship the material to its destination based on the mode of shipment recommended by NAVADS. This transportation cost is computed based on the weight and cube of the shipment using the lowest-cost carrier tender as determined by the Conus Freight Movement System

(CFMS)³. Block 12 is the actual total transportation cost obtained from the government bill of lading. The last column is simply the cost difference between the shipping cost of the NAVADS-recommended mode of shipment and the cost of transportation based on what actually was charged to the government to move the particular freight and/or requisition.

In order to discuss the information in Appendix C, it is necessary to aggregate the results of the data. Table V-1 summarizes the totals of the blocks 4, 5, 6, 11, 12, and 13 in Appendix C.

TABLE V-1

	PIECES (REQN)	WEIGHT (LBS)	CUBE (FT)	NAVADS COST (\$)	ACTUAL COST (\$)	COST DIFF (\$)
TOTALS	328	3089	513	4171.3	2184.5	1986.8

The above table is self-explanatory. To proceed with the calculation of some cost measures, this data can be approached in two different ways. For the first case, the weight and the cost difference are used. In this case, the average cost avoidance is \$0.64 for every pound of freight shipped. This means that the government has avoided

³CFMS is an automated system that is maintained by the Military Traffic Management Command. It stores tenders and tariff rates of all approved operating motor and rail carriers in CONUS. The CFMS is used by Freight Rate Specialists to determine the lowest cost carriers that operate between given points in CONUS. When used, the CFMS provides a list of potential carriers, a minimum of 6 carriers, in priority order from the lowest to the highest.

an additional cost of \$0.64 for every pound of freight shipped by judiciously selecting the appropriate mode of shipment.

Looking at it in another way, the cost difference can also be used to determine the average cost savings to ship each of the 328 requisitions. The result is a \$6.06 transportation cost avoidance for each requisition. If this sample is truly representative of the population of approximately 19,500 requisitions sent to Code 400 during the four-month period, this means that $19,500 \times \$6.06 = \$118,170$ in transportation costs were avoided by not using the NAVADS-recommended mode of shipment. At an annual rate, this is more than \$350,000 of transportation costs avoided. In addition to providing these savings, a reduction in the Code 400 workload could lead to a saving in the labor costs currently being expended to identify these savings. Clearly, it is important that these manual procedures be programmed into NAVADS.

VI. MANAGERIAL ISSUES IN SMALL PARCEL SHIPMENTS

This chapter outlines management issues at NSC San Diego, and it also discusses specific management initiatives implemented at the supply center. The last section of this chapter deals with the advantages and disadvantages of the current NAVSUP small parcel shipment policy.

A. NSC SAN DIEGO INITIATIVES

Management involvement in the shipment of small parcel items is constrained by various factors. Code 41, a part of the NSC San Diego organizational structure, is responsible for analyzing recommended changes to the NAVADS program. Although Code 41 is resident at NSC San Diego and can process changes in NAVADS program files, the changes cannot be implemented until the change notice has gone through various levels of NAVSUP approvals. The delay created by this process limits management ability to challenge every inconsistency in the shipping process and see an immediate result. This is especially felt by the managers at the NISTARS site.

Code 41 is located at the NSC San Diego main building located in downtown San Diego at Harbor Drive. The day-to-day management involvement is limited to those items sent to Code 400 for further mode-of-shipment determination. About 55 percent of all small parcel shipments are not challenged because they are determined by the NAVADS shipment decision logic. Of the other 45 percent of small shipments that is sent to Code 400 for packing and shipping, over 58 percent have historically been

changed from the NAVADS-recommended mode of shipment to a mode of shipment as deemed appropriate by Code 400 based on local operating guidelines.

1. Measures of Effectiveness

Measuring the effectiveness of NAVSUP small parcel shipping policy can be done in various ways. This thesis, however, focuses only on the decisions of NSC San Diego. In as much as the criteria (decision logic) for shipping small parcel items are already loaded in the NAVADS system, the important part of measuring the effectiveness of the policy relies heavily on the number of mode of shipment changes that occur after the shipping documentation, the DD Form 1348-1s, have been generated with the NISTARS interface process.

Management involvement of NSC San Diego is also measured by other factors, such as goals established by NAVSUP. For example, NSC San Diego is evaluated based on its performance against UMMIPS shipping time standards, and the number of warehouse refusals. However, these measures of effectiveness are beyond the scope of this thesis.

2. Management Initiative

NSC San Diego is currently refining an initiative it has implemented early this year. This initiative is called the SERVSMART initiative. This initiative is different from the widely known Navy SERVSMART⁴ [Ref. 12] concept used as outlets for selected

⁴ SERVSMART is a self-service store which is operated by an ashore supply activity to provide a ready supply of relatively low-cost items frequently required by customers. SERVSMART enables customers to obtain material expeditiously without having to prepare and submit a separate requisition for each item required.

repair parts and consumables. The SERVMART initiative focuses on the idea of shipment consolidations. For instance, if one customer has 75 or more requisitions in the queue, the NISTARS Central Controller will direct consolidated packing to send the materials to the SERVMART line. This area consolidates shipments to the 50 largest customers in San Diego and Long Beach. The initiative also provides better use of space which is limited at the supply center site. Because cost is an important issue, this initiative attempts to save numerous man-hours for shipment via local delivery because the items for a particular customer are consolidated at a place where workers travel shorter distances to group materials together. The consolidated items are assembled in one area and subsequently transferred to the customers' designated bays.

B. NAVSUP ISSUES

There are advantages and disadvantages of NAVSUP small parcel shipping policy. As outlined in the following subsections, NAVSUP must decide and weigh the circumstances that provide the best output in relation to its shipping policy.

1. Advantages

a. Because the determination of small parcel shipments and the decision criteria still rest largely on the local activity Installation Transportation Officer, NAVSUP is able to relieve itself of the procedural modes of management and can then focus on policy issues regarding physical distribution of Navy material.

b. More flexibility is provided to local ITOs in responding to fleet requirements for small shipments. The shipping ITO does not have to go through a long

chain of shipping approvals. This process of obtaining shipping approval from NAVMTO is obtained only on a case-by-case basis. Since there are many cases where the ITO is put into a situation where his authority to ship special cases of small parcel shipment is exercised, the ITO can best judge the situation based on what is readily available at his disposal to effect a small parcel shipment.

c. The system encourages management by exception. The NAVADS' System Constants File allows management by exception in that it can ignore some shipping features, i.e., project codes, that automatically direct a requisition to be processed in a different manner. However, entry of exceptions in the NAVADS System Constants Area file is difficult.

2. Disadvantages

a. There is always the danger of collusion between the shipper and the carrier. The supply system is replete with cases that have arisen from such relationships. Collusion can arise because, after a long period of time, the ITO has established good rapport with a carrier. When this happens, it becomes much more difficult to maintain the appearance of unbiasedness. Favors are sometimes exchanged. For example, a favored carrier may be given more business than he should be.

b. There is a limited use of volume movement tenders. Because volume of small parcel shipments on any one day and location is limited by the tender or the carrier set-up, the chances for consolidation are limited. Although meeting UMMIPS time standards is a significant factor in the movement of freight, some delay for consolidation purposes is not serious. The serious delays are often due to the shipping activity not

doing a good job of prioritizing its workload. In such instances, by the time the shipment is packed, it has already eaten up the number of days that the UMMIPS standard allows for the requisition to reach the customer. More efficient workload scheduling or hiring more personnel should allow the opportunity to use volume movement tenders or truckload tenders.

c. The CFMS, which the freight rate specialists at MTMC use to route the freight, has not incorporated tender and rate information from the U. S. Postal Service, Federal Express, or similar freight forwarders. Cost comparisons between the potential carriers and modes of shipments are limited. In addition, the CFMS is not readily accessible to local ITOs because the CFMS is only installed at the MTMC area commands. The local ITOs maintain their own file of carrier tenders in binders. For urgent shipments, this may mean using the most accessible carrier regardless of cost. Hence, cost considerations are not weighed against other shipment factors.

VII. SUMMARY AND CONCLUSION

A. SUMMARY

Chapter II provided an overview of the Navy logistics system, the Navy transportation system and the Navy supply system. It described the Navy logistic system emphasizing broad responsibilities within the organization. In addition, it identified organizational responsibilities for the transportation of Navy material.

Chapter III explored the transportation policy of the Department of the Navy and how such policy is translated by the Navy shippers.

Chapter IV described the systems and operations known as NISTARS and NAVADS at NSC San Diego. It also discussed the interface of these two systems. Finally, it discussed the manual process required to change the NAVADS recommended shipping mode.

Chapter V analyzed NSC San Diego small parcel shipments. It also discussed the potential transportation cost avoidance as a result of the comparison between the NAVADS-recommended mode of shipment and the actual transportation cost incurred by the government as a result of Code 400 manual override of NAVADS-recommended modes.

Chapter VI reviewed some managerial initiatives at NSC San Diego and also discussed the advantages and disadvantages of the small parcel shipment policy.

B. CONCLUSIONS

In conclusion, this study examined NAVSUP small package shipping procedures at NSC San Diego's NISTARS site. The study found that NAVADS sometimes fails to recommend the proper shipment mode. When Code 400 performed manual mode selection, there was a cost avoidance in the amount of \$0.64 for every pound of freight shipped or \$6.06 for every requisition shipped. This savings suggests that management involvement can play an important role in the shipment process. It provides some measure of effectiveness in the fulfillment of material supply and the transportation process. The study also suggests that the the implementation of the NAVSUP shipping policy at the NISTARS site in San Diego is limited in that only 45 percent of small parcel shipments is challenged.

C. RECOMMENDATIONS

1. A program trouble report must be initiated by NSC San Diego to alert FMSO for program analysis. The analysis recommendation should specifically focus on the area where: (1) NAVADS fails to choose the expected correct mode loaded in the NNF, (2) NAVADS' inability to recognize repairable shipments which are required to be shipped via traceable means, and (3) NAVADS not selecting surface modes for non-CASREF/NMCS/PMCS with project code 999.

2. An alternative solution is to explore the possibilities of replacing NAVADS with the Defense Warehousing and Storage System (DWAS). The DWAS system is an automated and integrated management control and shipment planning system used by

Defense Logistics Agency. Currently, NISTARS at NSC Oakland is part of DDRW and is operated by DLA. NAVADS has been replaced at Oakland by the DWAS concept. Material requirements orders (MROs) enter the DWAS system through the IBM computer at McClellan AFB. The DWAS system processes the MROs and feeds them through the Defense Distribution System (DDS), a subset of DWAS. The DDS interfaces with the UADPS-SP and NISTARS at NSC Oakland in processing the MRO transactions. Under the DWAS system, the rating, routing and offering of freight remain under the procedures established in the MTMR. However, the DWAS system seems to be a good potential alternative in correcting the mode-of-shipment problems. Three areas are particularly enticing in terms of what the DWAS can provide. These three areas are also in consonance with the general guidelines of DoD Directive 4500.9 where it suggests (1) maximum use of negotiated and guaranteed traffic tenders for volume and repetitive shipments, (2) shipment of material direct from vendors to users, and (3) the extension of UMMIPS transit times to permit use of lower cost transportation services and shipment consolidation.

It appears that NISTARS and DWAS can interface, as is currently being demonstrated at NSC Oakland. In September 1992, NSC San Diego will become a part of DDRW. Currently, there is no plan at NSC San Diego to replace NAVADS with DWAS immediately upon becoming part of DDRW. It is recommended that NSC San Diego should wait for the results of NAVADS and DWAS evaluations from Sharpe Army Depot before taking any action to replace NAVADS.

APPENDIX A

UM-XJ02C CHG 17
24 June 1988

MODE OF SHIPMENT CODES

1. Number of characters: One
2. Type of Code: Alphabetic/Numeric/Special Character
3. Explanation: The MILSTRIP/MILSTRAP code identifying the mode a shipment is planned to be shipped or is actually shipped.
4. The codes assigned are:

<u>MODE. SHIP</u>	<u>DESCRIPTION</u>
A	Motor, truckload
B	Motor, less than truckload
C	Van (unpacked, uncrated personal or government property)
D	Driveaway, truckaway, towaway
E	Bus
F	Military Airlift Command
G	Surface parcel post
H	Air parcel post
I	Government truck outside local delivery area
J	Air small parcel carrier
K	Rail, carload
L	Rail, less than carload
M	Surface freight forwarder
N	LOGAIR
O	Organic Military Air
P	Transportation Government Bills of Lading
Q	Commercial Air Freight (to include regular and expedited service, charters and air taxi)
R	Contractor Consolidated Small Parcel
S	Scheduled truck service (applies to contract carriage, guaranteed traffic routings and/or scheduled service)
T	Air Freight Forwarder
U	QUICKTRANS
V	SEAVAN
W	Water, river, lake, coastal (Commercial)
X	Bearer walkthrough
Z	MSC (controlled contract or arranged space) (Break bulk)
#	CONTRUCK
\$	ALCO
2	Government watercraft, barge
3	RORO (Roll-on Roll-off) Service
5	Surface Small Package Carriers
6	Military official mail (MOM)
7	Express mail
8	Pipeline

APPENDIX B

Code 401
01 JAN 91

PARCEL POST SHIPMENT CRITERIA

U.S.P.S. Parcel Post -70 lbs 108 inches length and girth MAX L-6'
U.P.S. -70 lbs 130 inches length and girth MAX L-9'
Roadway Package Service-100 lbs 130 inches length & girth MAX L-9'

1. CASREP
 - A. CONUS - UPS-AIR
 - B. OVERSEAS - Q-TRANS
 - C. CALIF. - UPS SURFACE
 - D. HAWAII - RPS
2. DLR (COG'S 2, 4, 6, 7, and 8)
 - A. FPO/APO - CERTIFIED PARCEL POST
 - B. CONUS - RPS (IF ZIP CODE QUALIFIES)
 - C. CALIF. - UPS-SURFACE
 - D. HAWAII - RPS
3. FMS
 - A. CONUS - RPS (IF ZIP CODE QUALIFIES)
 - 1.) UPS IF CAN'T GO RPS
4. WITHIN 300 MILE RADIUS (CALIF/ARIZONA)
 - A. 25 LBS AND BELOW - UPS-SURFACE
 - B. OVER 25 LBS TO 70 LBS - PARCEL POST
5. ROUTINE MATERIAL - ALL PRIORITIES
 - A. CONUS - RPS (IF ZIP CODE QUALIFIES)
 - B. OVERSEAS - PARCEL POST
 - C. CALIF. - OVER 25 LBS - PARCEL POST
 - D. CALIF. - PP - UNDER 25 LBS - UPS SURFACE
 - E. HAWAII - RPS
6. FBM/TRIDENT MATERIAL - GROUP I & II
 - A. CONUS - RPS (IF ZIP CODE QUALIFIES)
 - 1.) UPS IF CAN'T GO RPS
 - B. OVERSEAS - QUICKTRANS
 - C. FBM MATERIAL IS IDENTIFIED BY THE LETTER -F- IN THE FIRST POSITION OF THE PROJECT CODE
 - D. TRIDENT MATERIAL IS IDENTIFIED BY THE LETTER -X- IN THE FIRST POSITION OF THE PROJECT CODE

APPENDIX C

UNIT	DATE	SER#	P	W	C	NAV	MOS	SPLC	P	NAVAD	PAID	COST
ID						MOS	USE	DEST		SHPNG	SHPNG	DIFF
										COST	COST	
D20586	1122	3481	1	1	1	G	G	NA	3	NA	NA	NA
FB4678	1172	0026	1	4	0	G	G	NA	3	NA	NA	NA
FB4814	1067	0074	1	6	1	G	G	NA	3	NA	NA	NA
FB5240	1115	4035	1	1	1	G	G	NA	3	NA	NA	NA
FB5250	1158	3063	1	6	1	G	G	NA	1	NA	NA	NA
FB5270	1178	0950	1	1	1	B	G	876430291	1	29.4	3.79	25.6
FB5573	1164	0443	2	48	2	B	G	191470000	1	51.8	33.1	18.7
FB5573	1177	0927	1	1	1	B	G	191470000	3	51.8	13.8	38
FB5579	1080	0127	1	6	1	G	G	NA	2	NA	NA	NA
FB5606	1061	0137	1	49	2	Q	G	191470000	2	35.5	33.7	1.78
FB5621	1156	0515	2	65	9	B	G	191470000	1	51.8	43.4	8.44
FB6241	1065	0435	1	1	1	B	G	191470000	3	51.8	13.8	38
M67399	1123	2022	1	1	1	B	G	886148000	3	18	8.62	9.38
M95450	1065	6117	1	1	0	G	G	NA	3	NA	NA	NA
N00188	1169	A485	1	4	0	H	G	261000290	3	4.8	23.7	-19

N00189	1077	LN00	1	1	1	G	G	NA	3	NA	NA	NA
N00228	1177	0601	1	6	1	B	G	876430291	3	29.4	6.3	23.1
N00311	1086	A581	1	1	1	J	G	876430205	2	3.99	3.79	0.2
N00311	1170	0025	1	1	1	H	G	876430205	2	3.99	3.79	0.2
N00311	1086	A628	1	15	1	J	G	876430205	2	13.7	16.1	-2.4
N00311	1074	C161	1	5	1	H	G	876430205	3	5.61	6.3	0.69
N00311	1084	6105	1	15	1	H	G	876430205	1	13.7	16.1	-2.4
N00311	1086	A630	1	6	1	J	G	876430205	1	6.42	6.3	0.12
N00314	1170	2229	1	1	1	B	G	876430205	1	3.99	3.79	0.2
N00334	1157	DA50	1	1	1	J	G	876430205	1	3.99	3.79	0.2
N00334	1129	0520	1	1	0	G	G	NA	3	NA	NA	NA
N00383	1150	VK98	1	1	1	9	G	207800000	3	0.1	13.8	-14
N00389	1137	2112	1	1	1	B	G	191470000	3	51.8	13.8	38
N00406	1094	0484	7	63	3	G	G	NA	3	NA	NA	NA
N00406	1164	0170	1	3	1	5	G	845450290	2	41.8	17.6	24.2
N00406	1064	0821	1	3	0	G	G	NA	3	NA	NA	NA
N00604	1128	B047	1	1	1	B	G	876430205	2	29.4	3.79	25.6
N00612	1118	0858	1	13	1	5	G	417500000	3	48.3	29.6	18.7
N00620	1116	0184	1	2	1	H	G	844910000	2	3.99	17.6	-14

N00651	1115	0103	1	1	0	B	G	876430205	3	29.4	3.79	25.6
N00651	1087	0149	9	9	3	B	G	876430205	3	29.4	13.4	16
N00651	1176	F035	1	2	1	H	G	876430205	2	3.99	3.79	0.2
N00651	1112	0131	1	26	2	B	G	876430205	3	29.4	23.6	5.78
N00651	1094	0169	1	1	2	B	G	876430205	3	29.4	3.79	25.6
N03193	9161	1993	1	16	2	G	G	NA	3	NA	NA	NA
N05849	1138	0076	1	1	1	G	G	NA	1	NA	NA	NA
N05849	1138	D156	1	1	1	B	G	876447291	1	29.4	3.79	25.6
N08392	1120	3496	1	2	1	G	G	NA	3	NA	NA	NA
N09061	1084	6625	1	16	5	H	G	876447291	2	14.4	14.3	0.03
N09136	1131	8105	1	18	6	V	G	876430205	3	45.4	25	20.4
N20122	1134	AY46	1	4	1	B	G	876430291	3	29.4	6.3	23.1
N20682	1074	E400	1	1	0	9	G	876447291	3	0.1	3.79	-3.7
N20807	1074	E575	1	1	0	B	G	876447291	3	0.1	3.79	-3.7
N20883	1152	0311	1	42	1	9	G	876430205	1	4.2	29.8	-26
N20883	118	1783	1	1	1	9	G	876430205	3	0.1	3.79	-3.7
N20883	1181	1288	1	2	1	9	G	876430205	2	0.2	3.79	-3.6
N20883	1173	0113	1	1	1	9	G	876430205	2	0.1	3.79	-3.7
N20883	1152	0056	1	1	0	U	G	876430205	3	29.4	3.79	25.6

N20883	1181	0336	1	1	1	9	G	876430205	2	0.1	3.79	-3.7
N20883	1152	0449	1	2	0	9	G	876430205	3	0.2	3.79	-3.6
N20883	1152	0188	1	2	1	9	G	876430205	2	0.2	3.79	-3.6
N20883	1173	0031	1	1	0	H	G	876430205	3	3.99	3.79	0.2
N20887	1103	C542	1	1	0	Z	G	876430205	3	35.8	3.79	32
N20887	1103	C543	1	1	0	Z	G	876430205	3	35.8	3.79	32
N21037	1147	F042	1	1	0	B	G	845450290	3	41.8	8.6	33.2
N21038	1179	C001	1	1	0	B	G	845450290	3	41.8	8.6	33.2
N21297	1141	DE03	1	1	0	G	G	NA	3	NA	NA	NA
N21375	1144	0887	1	1	1	G	G	NA	1	NA	NA	NA
N21419	1083	1966	1	12	1	G	G	NA	2	NA	NA	NA
N30129	1171	A129	1	1	0	G	G	NA	3	NA	NA	NA
N35594	1135	A312	1	1	0	G	G	NA	2	NA	NA	NA
N35949	1135	A307	1	1	1	G	G	NA	2	NA	NA	NA
N35949	1135	A302	1	1	1	G	G	NA	2	NA	NA	NA
N35949	1135	A303	1	1	1	G	G	NA	2	NA	NA	NA
N41389	1113	9227	1	1	0	G	G	NA	3	NA	NA	NA
N45598	1138	7536	1	1	0	G	G	NA	3	NA	NA	NA
N48759	1089	0019	1	15	3	G	G	NA	3	NA	NA	NA

N48759	1151	0007	1	2	1	G	G	NA	2	NA	NA	NA
N52699	1124	0675	1	57	1	G	G	NA	3	NA	NA	NA
N52707	1132	0040	1	17	1	G	G	NA	3	NA	NA	NA
N53812	1114	FX16	2	6	3	G	G	NA	3	NA	NA	NA
N53852	1127	A769	1	9	1	G	G	NA	3	NA	NA	NA
N60042	1098	5405	1	1	1	G	G	NA	3	NA	NA	NA
N60050	1126	1279	1	1	1	G	G	NA	3	NA	NA	NA
N60050	1140	0378	1	2	1	G	G	NA	3	NA	NA	NA
N60050	1140	1325	1	41	1	V	G	887150000	3	98.5	23.6	74.9
N60087	1135	0081	1	9	1	G	G	NA	3	NA	NA	NA
N60462	1158	7109	1	40	2	G	G	NA	2	NA	NA	NA
N60462	1113	X035	1	2	0	V	G	845450290	3	45.4	8.6	36.8
N60462	1157	B309	1	1	1	V	G	845450290	1	45.4	8.6	36.8
N60495	1098	C040	1	10	1	G	G	NA	2	NA	NA	NA
N60701	1098	8775	1	45	9	H	G	887189290	2	32.9	23.6	9.31
N61119	1086	0040	1	5	0	B	G	876430205	3	29.4	6.3	23.1
N61119	1155	A543	1	1	0	B	G	876430205	3	29.4	3.79	25.6
N61119	1086	0080	1	1	1	B	G	876430205	3	29.4	3.79	25.6
N61119	1127	A547	1	13	2	X	G	876430205	3	NA	12.8	-13

N61119	1116	A561	1	20	1	G	G	NA	3	NA	NA	NA
N61119	1119	0019	2	32	5	B	G	876430205	3	29.4	24.7	4.75
N61119	1134	A417	1	58	1	H	G	876430205	3	41.2	31.8	9.43
N61119	1081	A422	1	3	1	G	G	NA	3	NA	NA	NA
N61577	1095	0942	1	14	7	B	G	876430205	3	29.4	13.7	15.7
N62383	1066	1003	2	2	1	H	G	876430205	3	3.99	3.79	0.2
N62481	1126	AE21	1	2	0	U	G	191470000	3	3.99	13.8	-9.8
N62507	1080	9305	1	1	0	G	G	NA	3	NA	NA	NA
N62507	1151	0669	1	4	1	G	G	NA	3	NA	NA	NA
N62507	1151	0679	3	70	2	H	G	876430205	2	48.9	36.7	12.2
N62507	1093	7851	1	1	0	G	G	NA	3	NA	NA	NA
N62507	1129	7800	1	30	9	H	G	876430205	2	23.3	24.3	-1
N62507	1093	7889	1	1	1	G	G	NA	2	NA	NA	NA
N62613	1101	0945	1	1	1	B	G	876430205	3	29.4	3.79	25.6
N62649	1140	0718	4	4	2	G	G	NA	3	NA	NA	NA
N62649	1064	0413	1	6	1	B	G	876430205	3	29.4	6.3	23.1
N62649	1106	0016	1	23	9	B	G	876430205	3	29.4	18.5	10.9
N62649	1175	0096	1	7	0	G	G	NA	1	NA	NA	NA
N62649	1121	0075	1	3	1	G	G	NA	3	NA	NA	NA

N62649	1119	0417	1	6	0	G	G	NA	3	NA	NA	NA
N62649	1140	0520	1	19	1	G	G	NA	3	NA	NA	NA
N62688	1129	1028	2	19	7	G	G	NA	3	NA	NA	NA
N62758	1108	4660	1	3	1	G	G	NA	1	NA	NA	NA
N62758	1077	4012	1	6	1	G	G	NA	3	NA	NA	NA
N62758	1107	F260	1	1	0	H	G	876430205	3	3.99	3.79	0.2
N62758	1105	4027	1	9	0	B	G	876430205	3	29.4	8.8	20.6
N62758	1084	4074	1	2	1	G	G	NA	3	NA	NA	NA
N62758	1148	4010	1	1	0	B	G	876430205	3	29.4	3.79	25.6
N62758	1144	4096	1	2	1	G	G	NA	3	NA	NA	NA
N62758	1131	4552	1	30	1	U	G	876430205	2	23.3	23.1	0.17
N62758	1077	A107	1	11	1	H	G	876430205	2	10.5	3.79	6.68
N62813	1170	3738	1	1	1	B	G	876430205	2	29.4	3.79	25.6
N62863	1066	7637	1	1	0	H	G	191470000	3	3.99	13.8	-9.8
N62863	1165	4069	2	2	1	U	G	191470000	2	3.99	13.8	-9.8
N62974	1155	1265	1	1	0	G	G	NA	3	NA	NA	NA
N62995	1148	FP76	1	1	1	V	G	798190280	1	45.4	8.6	36.8
N62995	1100	9034	1	12	2	H	G	798190280	3	11.3	16.3	-5
N62995	1165	FP64	1	3	0	G	G	NA	3	NA	NA	NA

N62995	1099	9064	2	20	9	H	G	798190280	3	16.9	22.7	-5.8
N63032	1120	2876	1	1	1	H	G	191470000	2	8.99	13.8	-4.8
N63042	1154	7794	1	2	1	H	G	879585290	3	3.99	13.8	-9.8
N63042	1154	7793	1	2	1	H	G	879585290	3	3.99	3.79	0.2
N63126	1128	1950	1	45	9	G	G	NA	2	NA	NA	NA
N63126	1161	GJNP	1	1	0	5	G	884170290	3	3.99	3.79	0.2
N63126	1168	0700	1	1	1	H	G	884170290	2	3.99	3.79	0.2
N63126	1079	FHNP	1	1	1	G	G	NA	2	NA	NA	NA
N63154	1140	0746	1	1	0	G	G	NA	3	NA	NA	NA
N63427	1095	4590	1	32	3	G	G	NA	3	NA	NA	NA
N63821	1140	2215	1	29	3	G	G	NA	3	NA	NA	NA
N63886	1141	4312	1	3	9	B	G	845450290	3	41.8	9.8	32
N63886	1175	2526	1	1	0	B	G	845450290	3	41.8	8.6	33.2
N63913	1070	7561	1	4	0	G	G	NA	3	NA	NA	NA
N65114	1063	1065	1	28	1	H	G	494970000	2	22	8.6	13.4
N65886	1156	3257	1	29	2	G	G	NA	3	NA	NA	NA
N65907	1078	3065	1	1	0	Z	G	844910000	3	35.8	3.79	32
N65923	1122	1878	1	1	1	G	G	NA	2	NA	NA	NA
N65951	1121	2676	1	1	0	Z	G	876430205	2	35.8	3.79	32

N66687	1171	THDA	1	1	1	H	G	876430205	2	8.99	3.79	5.2
N66965	1148	9312	1	1	1	B	G	884170290	3	18	3.79	14.2
N68308	1113	9850	1	17	1	G	G	NA	3	NA	NA	NA
N68445	1150	7601	1	42	3	G	G	NA	3	NA	NA	NA
N80015	1141	0311	1	11	1	G	G	NA	3	NA	NA	NA
R0118A	1178	CD33	1	27	1	9	G	889000294	3	2.79	12.9	-10
R0118A	1098	CD93	1	8	0	9	G	889000294	3	0.8	6.79	-6
R0118A	1098	CD94	2	6	1	9	G	889000294	2	0.6	7.4	-6.8
R03341	1077	0710	1	8	0	G	G	NA	3	NA	NA	NA
R03368	1147	0755	1	23	1	B	G	845450290	2	41.8	18.8	23
R03651	1098	0533	1	4	1	9	G	876430205	3	0.4	4.2	-3.8
R04620	1112	2204	1	2	0	9	G	883699000	3	0.2	13.2	-13
R04629	1127	1339	1	1	0	G	G	NA	3	NA	NA	NA
R04678	1155	1014	1	4	0	9	G	876430205	3	0.4	4.2	-3.8
R04678	1112	9907	1	1	1	9	G	876430205	3	0.1	3.79	-3.7
R04678	1127	C701	1	1	0	G	G	NA	3	NA	NA	NA
R04686	1061	3251	1	2	0	9	G	876430205	2	0.2	3.79	-3.6
R04686	1172	5988	1	19	1	9	G	876430205	2	1.9	12.4	-11
R04686	1072	3514	1	1	0	G	G	NA	3	NA	NA	NA

R04686	1135	4797	1	13	2	9	G	876430205	3	1.3	11.1	-9.8
R04686	1070	3474	1	1	0	9	G	876430205	3	0.1	3.79	-3.7
R04686	1128	4548	1	1	0	9	G	876430205	3	0.1	3.79	-3.7
R04686	1106	4206	1	1	0	G	G	NA	3	NA	NA	NA
R04686	1072	3541	2	4	3	G	G	NA	3	NA	NA	NA
R04688	1113	3307	1	1	0	9	G	876430205	3	0.1	3.79	-3.7
R04688	1087	2692	1	1	1	G	G	NA	3	NA	NA	NA
R04688	1102	2985	1	1	0	B	G	876430205	3	29.4	3.79	25.6
R04688	1113	3248	1	1	0	9	G	876430205	3	0.1	3.79	-3.7
R05834	1083	0018	1	54	2	B	G	876430205	3	29.4	32.6	-3.2
R05840	1150	0149	1	1	0	B	G	876430205	3	29.4	3.79	25.6
R05847	1180	3453	1	17	3	G	G	NA	3	NA	NA	NA
R05849	1135	3740	1	3	0	G	G	NA	3	NA	NA	NA
R05849	1135	3740	1	3	0	G	G	NA	3	NA	NA	NA
R07198	1124	1854	1	1	0	G	G	NA	3	NA	NA	NA
R07198	1124	1810	1	1	0	B	G	876430205	3	29.4	3.79	25.6
R07202	1133	RK09	1	1	0	B	H	876430205	3	29.4	3.79	25.6
R08810	1109	A682	1	9	0	G	G	NA	3	NA	NA	NA
R09112	1091	1473	1	1	1	B	G	876430205	3	29.4	3.79	25.6

R09112	1065	AR14	1	1	1	B	G	876430205	1	29.4	3.79	25.6
R09112	1105	0119	1	1	0	G	G	NA	3	NA	NA	NA
R09124	1125	0351	1	8	1	U	G	876430205	3	3.99	7.2	-3.2
R09124	1119	3616	1	1	1	Z	G	876430205	2	35.8	3.79	32
R09136	1079	1832	1	1	1	Z	G	876430205	2	35.8	3.79	32
R09136	1160	1885	1	1	1	B	G	876430205	3	29.4	3.79	25.6
R09136	1075	BA00	1	1	1	Z	G	876430205	3	35.8	3.79	32
R09463	1077	F710	1	1	1	9	G	876430205	1	0.1	3.79	-3.7
R09644	1134	F062	1	1	1	5	G	876430205	2	3.99	3.79	0.2
R09793	1081	F858	1	1	1	Z	G	876430205	3	35.8	3.79	32
R09808	1085	1598	1	1	0	U	G	889513000	3	3.99	3.79	0.2
R09930	1177	F900	1	10	2	G	G	NA	3	NA	NA	NA
R20043	1086	1697	1	8	4	9	G	845450290	3	0.8	7.2	-6.4
R20066	1149	3453	1	2	1	9	G	876430205	3	0.2	3.79	-3.6
R20221	1164	4604	1	1	0	G	G	NA	3	NA	NA	NA
R20224	1126	2161	1	2	2	9	G	876430205	2	0.2	3.79	-3.6
R20224	1123	2005	1	6	1	9	G	876430205	3	0.2	6.3	-6.1
R20248	1134	3313	1	13	3	9	G	883699000	3	0.6	6.3	-5.7
R20248	1133	3278	1	1	0	X	G	883699000	2	NA	11.9	-12

R20586	1068	2642	1	30	9	9	G	876430205	3	3	31.4	-28
R20598	1133	3871	1	1	1	9	G	876430205	3	0.1	3.79	-3.7
R20598	1102	3504	1	1	1	9	G	876430205	3	0.1	4.2	-4.1
R20598	1155	4095	1	1	1	9	G	876430205	2	0.1	3.79	-3.7
R20602	1115	3975	1	5	2	9	G	876430205	3	0.5	5.15	-4.7
R20616	1156	5460	1	45	4	G	G	NA	3	NA	NA	NA
R20616	1061	4689	1	5	0	V	G	876430205	3	45.4	5.15	40.2
R20682	1064	4484	1	5	1	V	H	876447291	2	45.4	5.15	40.2
R20682	1181	D513	1	2	0	B	H	876447291	2	29.4	4.59	24.8
R20807	1089	4285	1	2	1	9	G	876447291	2	0.2	4.59	-4.4
R20807	1094	4469	1	1	1	X	G	876447291	3	NA	3.79	-3.8
R20993	1119	6501	1	22	1	G	G	NA	3	NA	NA	NA
R21052	1120	3109	1	9	3	B	G	876430205	3	29.4	8.2	21.2
R21063	1107	3120	1	21	2	G	G	NA	3	NA	NA	NA
R21063	1174	0774	1	8	2	B	G	876430205	3	29.4	7.8	21.6
R21063	1174	0308	1	3	0	G	G	NA	3	NA	NA	NA
R21108	1155	3358	1	1	1	B	G	876430205	2	29.4	3.79	25.6
R21108	1108	2419	1	1	1	B	G	876430205	3	29.4	4.59	24.8
R21110	1064	1296	1	1	1	G	G	NA	3	NA	NA	NA

R21198	1060	1862	1	1	0	9	G	876430205	3	0.1	3.79	-3.7
R21232	1136	2908	1	1	1	9	G	883699000	3	0.1	3.79	-3.7
R21428	1112	3416	1	12	9	B	G	876430205	3	29.4	21.6	7.8
R21430	1125	3156	1	2	0	9	G	876430205	3	0.2	4.59	-4.4
R21430	1100	2822	1	6	6	9	G	876430205	3	0.6	6.3	-5.7
R21447	1134	5504	1	7	0	H	G	883699000	3	7.23	8.4	-1.2
R21452	1148	0210	1	1	1	B	G	876430205	3	29.4	3.79	25.6
R21452	1123	5665	1	1	0	B	G	876430205	3	29.4	3.79	25.6
R52689	1155	2961	1	6	1	V	G	876430205	3	45.4	7.3	38.1
R52692	1072	5652	1	1	0	5	G	876430205	3	3.89	3.79	0.1
R52692	1074	0873	1	2	0	G	G	NA	3	NA	NA	NA
R52693	1131	8527	1	1	0	9	G	876430205	3	0.1	3.79	-3.7
R52705	1096	3065	1	1	0	B	G	876430205	3	29.4	3.79	25.6
R52705	1104	3293	1	14	1	G	G	NA	3	NA	NA	NA
R52705	1138	3828	1	8	0	G	G	NA	3	NA	NA	NA
R52705	1100	3184	2	43	5	B	G	876430205	2	29.4	35.6	-6.2
R52705	1138	3827	1	7	0	G	G	NA	3	NA	NA	NA
R52712	1162	0694	1	25	1	H	G	845450290	2	20.1	22.5	-2.4
R52712	1101	4457	1	1	0	F	G	845450290	3	41.8	8.6	33.2

R52712	1101	4458	1	1	1	B	G	845450290	2	41.8	8.6	33.2
R52712	1165	0901	1	1	0	B	G	845450290	3	41.8	8.8	33
R52962	1171	6210	1	1	0	G	G	NA	2	NA	NA	NA
R54048	1154	2262	1	1	1	9	G	876500290	3	0.1	4.59	-4.5
R54052	1128	3215	1	33	7	B	G	876430205	3	29.4	30.9	-1.5
R54052	1134	3398	1	3	0	H	G	876430205	3	3.99	4.2	-0.2
R54052	1143	3527	1	1	0	9	G	876430205	3	0.1	3.79	-3.7
R54052	1143	3529	1	10	1	9	G	876430205	3	1	9.8	8.8
R54060	1168	3856	1	6	0	G	G	NA	3	NA	NA	NA
R54060	1170	4001	1	1	0	B	G	876430205	3	29.4	3.79	25.6
R54065	1101	2610	1	2	1	9	G	876430205	3	0.2	4.59	-4.4
R54066	1163	AD06	1	2	0	G	G	NA	3	NA	NA	NA
R55306	1066	0129	1	1	1	Z	G	876500290	3	35.8	4.59	31.2
R55418	1053	1533	1	4	1	G	G	NA	3	NA	NA	NA
R55418	1163	2417	1	41	1	G	G	NA	3	NA	NA	NA
R55418	1070	1731	1	19	2	G	G	NA	3	NA	NA	NA
R55418	1064	1712	2	9	2	G	G	NA	3	NA	NA	NA
R63923	1084	F383	1	1	0	U	G	876430205	3	3.99	3.79	0.2
R65185	1093	F017	1	8	0	9	G	876430205	3	0.8	7.2	-6.4

R65918	1063	1340	1	45	1	G	G	NA	3	NA	NA	NA
R65918	1178	0184	1	1	0	9	G	876430205	1	0.1	3.79	-3.7
R68251	1135	0056	2	2	2	G	G	NA	2	NA	NA	NA
R68251	1157	2067	1	1	1	G	G	NA	1	NA	NA	NA
R68251	1086	4994	1	3	3	G	G	NA	1	NA	NA	NA
R68828	1176	7894	1	17	1	9	G	883699000	3	1.7	15.3	-14
R68847	1085	F026	1	1	1	5	G	865185290	3	3.79	8.9	-5.1
R81457	1116	0166	1	9	0	G	G	NA	3	NA	NA	NA
V03359	1103	D438	1	1	0	G	G	NA	3	NA	NA	NA
V03359	1126	1782	2	58	4	G	G	NA	2	NA	NA	NA
V03359	1073	4284	1	10	1	G	G	NA	2	NA	NA	NA
V03363	1109	0504	2	5	2	G	G	NA	3	NA	NA	NA
V03363	1109	0480	1	13	1	H	G	207800000	3	12.9	38.6	-26
V04628	1166	K360	1	18	1	H	G	191470000	1	15.6	21.7	-6.1
V04638	1102	6646	1	1	1	G	G	NA	3	NA	NA	NA
V04639	1139	FD17	1	1	1	G	G	NA	3	NA	NA	NA
V04639	1126	C926	1	7	1	G	G	NA	3	NA	NA	NA
V04639	1127	C961	1	11	2	G	G	NA	3	NA	NA	NA
V04639	1152	0302	1	1	0	G	G	NA	3	NA	NA	NA

V04696	1154	0517	1	20	2	Z	G	417500000	3	35.8	23.9	11.9
V05150	1130	6085	1	9	1	B	G	261000290	2	51.8	18.8	33
V05154	1154	2072	1	60	7	B	G	261000290	2	51.8	42.8	8.99
V05154	1154	2372	1	3	1	B	G	261000290	2	51.8	11.4	40.4
V05851	1151	0883	1	1	0	B	G	261000290	3	51.8	7.8	44
V05851	1121	0994	1	7	1	U	G	261000290	3	51.8	16.2	35.6
V07175	1155	B670	1	1	1	B	G	261000290	3	51.8	7.8	44
V07350	1065	0252	1	1	1	B	G	261000290	2	51.8	7.8	44
V07352	1100	0749	2	10	1	G	G	NA	2	NA	NA	NA
V09167	1135	7519	1	1	0	G	G	NA	3	NA	NA	NA
V20033	1143	A591	1	4	1	H	G	261000290	2	4.8	13.6	-8.8
V20042	1136	2812	1	49	3	G	G	NA	2	NA	NA	NA
V20042	1119	2523	1	60	7	B	G	261000290	2	51.8	46.8	499
V20044	1163	2346	1	12	1	G	G	NA	2	NA	NA	NA
V20223	1153	B341	1	33	1	H	G	261000290	2	25.2	34.9	-9.6
V20223	1134	B233	1	1	1	B	G	261000290	3	51.8	7.8	44
V20589	1163	B341	1	70	1	B	G	261000290	3	51.8	46.6	5.2
V20604	1129	B843	1	18	1	G	G	NA	2	NA	NA	NA
V20613	1131	0952	1	40	1	G	G	NA	3	NA	NA	NA

V20615	1065	B248	1	1	1	Z	G	417500000	2	35.8	13.6	22.2
V20624	1134	C696	1	2	0	G	G	NA	3	NA	NA	NA
V20632	1060	6477	1	1	1	H	G	261000290	2	3.99	7.8	-3.8
V20632	1152	0472	1	1	1	H	G	261000290	2	3.99	7.8	-3.8
V20632	1152	0836	1	10	3	G	G	NA	2	NA	NA	NA
V20632	1152	0468	1	7	3	G	G	NA	2	NA	NA	NA
V20632	1088	0190	1	1	1	H	G	261000290	2	3.99	7.8	-3.8
V20635	1145	0084	1	37	1	G	G	NA	2	NA	NA	NA
V20635	1154	0405	1	6	0	B	G	261000290	3	51.8	11.1	40.7
V20834	1125	C230	1	20	4	U	G	417500000	2	16.9	13.6	3.27
V20834	1123	1364	1	10	1	G	G	NA	2	NA	NA	NA
V20834	1125	C238	1	4	0	B	G	417500000	3	48.3	15.3	33
V20835	1135	C744	1	1	0	B	G	417500000	3	48.3	13.6	34.7
V20865	1117	0160	1	11	2	H	G	417500000	3	10.5	16.4	-6
V21098	1074	0064	1	10	1	H	G	261000290	2	9.66	19.1	-9.5
V21236	1138	B959	1	1	1	B	G	417500000	3	48.3	13.6	34.7
V21247	1150	6097	1	1	0	G	G	NA	3	NA	NA	NA
V21247	1110	1423	1	12	1	H	G	261000290	3	11.3	21.6	-10
V21344	1164	C476	1	1	1	B	G	261000290	2	51.8	7.8	44

V45515	1172	0093	1	19	1	G	G	NA	3	NA	NA	NA
V46649	1081	0314	4	39	4	G	G	NA	3	NA	NA	NA
V52701	1114	A193	1	1	1	H	G	191470000	1	3.99	7.8	-3.8
V52709	1130	C369	1	1	1	H	G	261000290	1	3.99	7.8	-3.8
V58179	1110	B785	1	5	1	G	G	NA	3	NA	NA	NA
W34UUS	1064	3299	1	1	0	G	G	NA	3	NA	NA	NA
W68EVQ	1122	AADU	1	5	0	G	G	NA	3	NA	NA	NA
WF6J64	1137	0008	1	1	0	G	G	NA	3	NA	NA	NA
WK0FPY	1123	0908	1	60	2	B	G	191470000	3	51.8	44.9	6.94

LIST OF REFERENCES

1. NAVSUP, NAVSUP Management Handbook, 11 January 1991.
2. Marcinek, Carol, NISTARS, 29 November 1990.
3. OPNAV Instruction 4000.85, Navy Logistic System, 18 September 1986.
4. NAVSUP Instruction 4400.78C, Department of Defense Management Reference Book, 1 January 1985.
5. OPNAV Instruction 4600.24C, Responsibilities For Management of Navy Transportation, 14 June 1989.
6. NAVSUP Instruction 5450.86D, Mission And Functions of Navy Fleet Material Support Office, 8 April 1982.
7. FMSO, Navy Automated Transportation Documentation System, 2 November 1990.
8. NAVSUP Instruction 4400.89, Navy Repairables Management Manual, 09 April 1990.
9. DoD Directive, 4500.9, Transportation and Traffic Management, 26 January 1989.
10. NAVSUP Instruction 4600.70, Military Traffic Management Regulations, April 1990.
11. DoD Directive 4410.6, Uniform Material Movement and Issue Priority System, 30 October 1980.
12. NAVSUP Manual, Supply Ashore, Vol. II, 22 September 1982.
13. NAVSUP Manual, Supply Afloat, Vol. I, 12 November 1989.

INITIAL DISTRIBUTION LIST

1. Defense Technical Information Center 2
Cameron Station
Alexandria, Virginia 22304-6145
2. Dudley Knox Library Code 052 2
Naval Postgraduate School
Monterey, California 93943-5002
3. Defense Logistics Studies Information Exchange 1
U. S. Army Logistics Management Center
Fort Lee, Virginia 23801
4. Naval Supply Systems Command 1
Attn Code SUP 054
Washington, D. C. 20376-5000
5. Commanding Officer 1
Naval Supply Center, Code 00
San Diego, California 96132
6. Miss Carol Mott 1
Naval Supply Center, Code 301
San Diego, California 96132
7. Professor Dan C. Boger, Code AS/Bo 1
Department of Administrative Sciences
Naval Postgraduate School
Monterey, California 93943-5008
8. Professor Alan W. McMasters, Code AS/Mg 1
Department of Administrative Sciences
Naval Postgraduate School
Monterey, California 93943-5008
9. LT Benedicto L. Coloma 1
231 Spinney Way
Suisun City, California 94585