

NPS-ME-91-05

NAVAL POSTGRADUATE SCHOOL

Monterey, California



AN EVALUATION OF ^{^^^}EHD ENHANCEMENT
AND THERMOACOUSTIC REFRIGERATION
FOR NAVAL APPLICATIONS

S. B. MEMORY

DECEMBER 1991

Approved for public release; distribution unlimited

ed for:

Taylor Research Center, Annapolis, MD

FedDocs
D 208.14/2
NPS-ME-91-05

202.10/2:
RS-116-91-06, P. 2

NAVAL POSTGRADUATE SCHOOL
Monterey, California

Rear Admiral R. W. West, Jr
Superintendent

H. Shull
Provost

This report was prepared for and funded by the David Taylor Research Center,
Annapolis, MD 21402-5067.

Reproduction of all or part of this document is authorized.

This paper was prepared by:

11 1 11

A. J. HEALEY
Chairman,
Department of Mechanical
Engineering

PAUL J. MARTO
Dean of Research

REPORT DOCUMENTATION PAGE

Form Approved
OMB No 0704-0188

1a REPORT SECURITY CLASSIFICATION unclassified			1b RESTRICTIVE MARKINGS			
2a SECURITY CLASSIFICATION AUTHORITY			3 DISTRIBUTION AVAILABILITY OF REPORT approved for public release, distribution unlimited			
2b DECLASSIFICATION/DOWNGRADING SCHEDULE						
4 PERFORMING ORGANIZATION REPORT NUMBER(S) NPS-ME-91-05			5 MONITORING ORGANIZATION REPORT NUMBER(S)			
6a NAME OF PERFORMING ORGANIZATION Naval Postgraduate School		6b OFFICE SYMBOL (If applicable) ME	7a NAME OF MONITORING ORGANIZATION David Taylor Research Center			
6c ADDRESS (City, State, and ZIP Code) Mechanical Engineering Department (Code ME) Monterey, CA 93943-5000			7b ADDRESS (City, State, and ZIP Code) Annapolis, MD 21402-5067			
8a NAME OF FUNDING/SPONSORING ORGANIZATION David Taylor Research Center		8b OFFICE SYMBOL (If applicable) DTRC	9 PROCUREMENT INSTRUMENT IDENTIFICATION NUMBER N0016791WR10357			
8c ADDRESS (City, State, and ZIP Code) Annapolis, MD 21402-5067			10 SOURCE OF FUNDING NUMBERS			
		PROGRAM ELEMENT NO	PROJECT NO	TASK NO	WORK UNIT ACCESSION NO	
11 TITLE (Include Security Classification) An Evaluation of EHD Enhancement and Thermoacoustic Refrigeration for Naval Applications						
12 PERSONAL AUTHOR(S) S. B. Memory						
13a TYPE OF REPORT Technical		13b TIME COVERED FROM Jul 91 TO Sept 91		14 DATE OF REPORT (Year, Month, Day) 30 Dec 91		15 PAGE COUNT 46
16 SUPPLEMENTARY NOTATION						
17 COSATI CODES			18 SUBJECT TERMS (Continue on reverse if necessary and identify by block number)			
FIELD	GROUP	SUB-GROUP	Electrohydrodynamic Enhancement, Boiling and Condensation, Thermoacoustic Refrigeration			
19 ABSTRACT (Continue on reverse if necessary and identify by block number)						
An evaluation has been made of two different techniques which could prove valuable for Naval refrigeration needs in the future. The first is electrohydrodynamic (EHD) enhancement of pool boiling and condensation heat transfer; this has been shown to provide significant enhancements for both modes of heat transfer under certain conditions and could provide increases in efficiency of present vapor-compression systems. EHD techniques are quite advanced and prototype condenser and evaporator bundles are currently being tested. The second technique is an alternative refrigeration technology called thermoacoustic refrigeration; alternative technologies have become increasingly attractive over recent years due to environmental concerns over CFCs. Thermoacoustic refrigeration uses acoustic power to pump heat from a low temperature source to a high temperature sink. It is still in the early stages of development and can presently accomodate only small thermal loads. However, its general principles of operation have been proven and its present capacity and efficiency limitations are not seen as a problem in the long term.						
20 DISTRIBUTION AVAILABILITY OF ABSTRACT <input checked="" type="checkbox"/> UNCLASSIFIED UNLIMITED <input type="checkbox"/> SAME AS RPT <input type="checkbox"/> DTIC USERS				21 ABSTRACT SECURITY CLASSIFICATION unclassified		
22a NAME OF RESPONSIBLE INDIVIDUAL S. B. Memory			22b TELEPHONE (Include Area Code) 408-646-3428		22c OFFICE SYMBOL ME	

LIST OF CONTENTS

	<u>Page</u>
1. GENERAL INTRODUCTION	2
2. ELECTROHYDRODYNAMIC ENHANCEMENT (EHD)	6
2.1 Introduction	6
2.2 Force Components in EHD Coupling Equations	6
2.3 EHD Enhancement Applied to Phase Change	8
2.3.1 Boiling	8
2.3.2 Condensation	13
2.4 Feasibility of EHD Enhancement for Naval Applications	15
3. THERMOACOUSTIC REFRIGERATION	19
3.1 Introduction	19
3.2 Basic Thermodynamic Concepts	19
3.2.1 Heat Engines	19
3.2.2 Thermoacoustic Engines	21
3.3 Thermoacoustic Refrigerator	24
3.4 Feasibility of Thermoacoustic Refrigeration for Naval Applications	26
4. ACKNOWLEDGEMENTS	27
5. REFERENCES	28

1. GENERAL INTRODUCTION

The US Navy today operates a wide variety of refrigeration and air-conditioning plants aboard its ships and submarines. These vapor compression plants use chlorofluorocarbons (CFCs) as the working fluid. Developed almost 60 years ago, CFCs are unique in that they are low in toxicity, nonflammable, noncorrosive, compatible with many other materials and extremely stable. However, it is this extreme stability which causes CFC compounds to break down only in the stratosphere when subjected to intense ultraviolet radiation. This breakdown produces chlorine which has been linked to possible depletion of the earth's protective ozone layer. Because of these serious environmental consequences, the Montreal Protocol, signed by 24 countries in 1987 (and revised in 1990), limited the production of CFCs in the short term and called for a cessation of their production by the year 2000.

The Navy is taking steps to comply with the Montreal Protocol including:

- prohibiting the direct release of Ozone Depleting Substances (ODSs) by 1993
- phasing out non-essential and non-military uses of ODSs as soon as possible
- implementing conservation and recycling

It is also actively involved in R&D programs not only to find other environmentally acceptable fluids for use in existing and future vapor compression plants but also to help develop alternative refrigeration technologies (eliminating the vapor compression cycle completely) in the longer term.

Most of the fluids that could be used to replace the existing refrigerants fall into two categories, hydrofluorocarbons (HFCs) which contain no chlorine and therefore have zero Ozone Depletion Potential (ODP) and hydrochlorofluorocarbons (HCFCs). HCFCs do contain chlorine, but the addition of hydrogen to the CFC structure allows virtually all the chlorine to be dissipated in the lower atmosphere before it can reach the ozone layer. HCFCs therefore have much lower values of ODP, ranging from 2 to 10% that of CFCs. The hydrogen also causes these HCFCs to be less stable in the atmosphere than CFCs, thus greatly reducing atmospheric lifetime - from 2 to 25 years compared with about 100 years or longer for CFCs.

The Navy currently uses four different CFCs for a variety of tasks: CFC-12 and CFC-114 are used solely as refrigerants, CFC-113 is used solely as a solvent/cleaner and CFC-11 is used for both purposes. Existing shipboard air-conditioning (AC) systems, are one of two types depending on the required capacity: for plants of less than 100 tons, CFC-12 is used in an in-tube evaporator using a reciprocating compressor (CFC-11 still exists in some plants but this is being phased out due to its unfavorable operating pressure). For plants in excess of 100 tons capacity, CFC-114 is used in a flooded evaporator with a centrifugal compressor. For these existing plants, there are no direct 'drop-in' replacements. Rather the Navy has identified alternative fluids which have the closest comparable operating conditions with existing systems, limiting any changes to equipment modifications such as compressor size. With this in mind, the Navy has focused attention on HFC-134a as a replacement for CFC-12 and HCFC-124 as a replacement for CFC-114 in its on-board chillers and heat exchangers. As an example, HCFC-124 can be used at a relatively low operating pressure (about 2 atmospheres absolute) compared with 1 atmosphere for CFC-114; this is of prime importance in shipboard applications. Furthermore, the ODP of HCFC-124 is only about 3% that of CFC-114, the global warming potential (GWP) is less than 2% that of CFC-114 and the atmospheric lifetime is estimated to be 1/25th (i.e. about 8 years) that of CFC-114. However, for these larger centrifugal AC systems, the equipment modifications that would need to be made are quite extensive.

The Navy is also considering an ether-based alternative (E-134) which contains no chlorine as a drop-in replacement for CFC-114. From preliminary thermodynamic data developed by NIST (National Institute of Standards and Technology), the required operating conditions for E-134 are even more compatible with those presently used with CFC-114, with an operating pressure of just under 1 atmosphere. This, coupled with the fact that the ODP is zero, makes E-134 look very attractive for future use. However, its present availability is questionable and it is looked upon as a possible longer-term 'drop-in' replacement for CFC-114 (i.e. for existing plants that will be around for another 20 years). For future AC designs, HFC-134a has been proposed for use in both large and small capacity systems, together with the use of a quieter, more efficient twin-screw compressor for systems under 100 tons.

Simply identifying a replacement fluid for use in vapor compression systems is only part of the problem. Unfortunately, the heat-transfer characteristics of these alternative fluids are as yet unknown: furthermore, their cost will be considerably

more than existing CFCs. Consequently, the Navy is looking at ways of enhancing the heat transfer characteristics in both the evaporator and condenser with a view to reducing the size of existing systems. One promising area here is the use of enhanced boiling and condensing surfaces; this is currently being studied at the Naval Postgraduate School using CFC-113 and CFC-114 on single tubes and small bundles (Memory et al (1992a, 1992b, 1992c, 1992d)) and will continue with HCFC-124 during 1992.

The use of enhanced surfaces is a passive way of increasing the heat transfer i.e. no external forces are applied. An alternative method of enhancing the heat transfer is electrohydrodynamic (EHD) enhancement which utilizes an intense electric field, applied to the heat-transfer surface, to modify the hydrodynamics of the flow. Due to the application of this external force, EHD is considered an active enhancement technique. The actual EHD mechanism causing enhancement depends on the heat transfer process involved (i.e. single phase convection or two-phase). Much recent work has focused on change-of-phase heat-transfer enhancement using EHD techniques and early results promise larger enhancements than those found with single phase convection heat transfer. However, it is unknown whether EHD, or a combination of EHD with enhanced tubing, would be a feasible enhancement technique for Naval applications.

The Navy is also considering alternative refrigeration technologies that do not use the vapor compression cycle. A good review of such technologies and their suitability for Naval applications is given by Gilmour (1990). One such technology is thermoacoustic refrigeration which uses sound waves to compress and expand harmless gas molecules (such as helium) inside a tube. As the molecules expand at one end of the tube (due to a sound pulse passing through), they cool down and take heat from the tube walls. These molecules then compress at the other end of the tube (having passed through a heat exchanger in the center), further warming up, giving up their heat as they collide with the walls. The net effect is to heat one end and cool the other end of the tube. Necessary refrigeration could then be obtained by passing some suitable fluid past the cooled end. This technique has been developed into a cryocooler for space purposes by the Department of Physics at the Naval Postgraduate School, and may have significant potential for Naval applications.

The purpose of this report is to review the recent work done on both EHD enhancement and thermoacoustic refrigeration and evaluate whether either technology has long-term potential for the Navy based on limitations imposed by shipboard application.

2. ELECTROHYDRODYNAMIC ENHANCEMENT (EHD)

2.1 Introduction

Electrohydrodynamic (EHD) means the coupling of a flow field with a high voltage, low current electric field in a low electrical conductivity medium. Over 40 years ago, Kronig and Ahsmann (1949) demonstrated that heat transfer in liquids could be enhanced by the action of an electric field by destabilizing the thermal boundary-layer near the wall. This increased mixing of the bulk liquid can lead to significant heat-transfer enhancement. However, the specific enhancement mechanism depends strongly on both the heat transfer process involved and the type of fluid used and it is therefore useful to study the individual force components that affect a dielectric medium of permittivity ϵ when subjected to an electric field vector \mathbf{E} . For an excellent summary of EHD behavior (with a summary of research carried out until 1978), the reader is referred to Jones (1978).

2.2 Force Components in EHD Coupling Equations

The only modification to the hydrodynamic equations is a body force term, \bar{f}_e , which represents the fluid response to the electric field vector:

$$\rho \left(\frac{d\bar{V}}{dt} \right) = -\nabla p + \rho \bar{g} + \bar{f}_e - \mu \nabla^2 \bar{V} \quad (1)$$

This body force term, derived by Landau and Lifshitz (1963), is generally expressed as:

$$\bar{f}_e = \rho_e \bar{E} - \frac{1}{2} \bar{E}^2 \nabla \epsilon - \nabla \left[\frac{1}{2} \rho \bar{E}^2 \left(\frac{\partial \epsilon}{\partial \rho} \right)_T \right] \quad (2)$$

The first term on the right hand side of equation (2) represents the electrophoretic component which results from the Coulomb force exerted by an electric field upon net free electric charge in a fluid. Anything that results in free charge build up (such as non-uniformities in the electrical conductivity due to convective heating) can be acted on by the electric field and cause the electrophoretic component to be

significant. An example of this is corona wind (which may be thought of as a free jet that is discharged into a fluid of the same type) that accompanies a corona discharge in gases and liquids; indeed, in gases, the corona discharge is the primary driving force behind the heat-transfer enhancement due to interaction between the discharge and bulk fluid. It is the strongest EHD force term and usually dominates in both conducting and insulating liquids.

The second term in equation (2) represents the dielectrophoretic component resulting from the spatial change of dielectric permittivity ϵ (often termed the polarization force since it arises from the polarization of the host medium). It is usually weaker than the electrophoretic component, but can dominate in cases where an a.c. field is imposed on an insulating dielectric. In a homogeneous single phase flow, significant dielectrophoretic forces can only exist when there is a temperature gradient maintained i.e. heat transfer applications where $\epsilon = \epsilon(T)$; however, for two-phase applications, due to large interfacial changes in permittivity, dielectrophoretic forces may also exist for adiabatic applications. The third term in equation (2) represents the electrostrictive component caused by inhomogeneity of the electric field strength. Together with the second term, it represents the force on dielectric materials; however, in a bounded hydrodynamic problem, it produces no net circulatory force and consequently plays no significant part in the enhancement process.

For convection heat transfer, if both electrical conductivity and dielectric permittivity vary spatially (as is usually the case with nonisothermal insulating dielectrics), it is uncertain as to whether the electrophoretic or dielectrophoretic component dominates in a given situation. An important parameter associated with which component dominates is the charge relaxation time, which is the rate at which free charge relaxes from the bulk to the boundary of a dielectric mass; it is defined as the ratio of dielectric permittivity to electrical conductivity. If the frequency of an a.c. electric field is much greater than the reciprocal of the charge relaxation time, then no free electric charge can build up in the fluid and the dielectrophoretic component is the dominant term; this can lead to significant motion of the fluid elements to regions of stronger electric field intensity. This also makes the dielectrophoretic component especially important for EHD phenomena associated with phase change where there can be significant difference between liquid and vapor permittivity. For all other cases where the dielectric permittivity

of a medium is constant, the dielectrophoretic component is negligible and the electrophoretic term usually dominates.

2.3 EHD Enhancement Applied to Phase-Change

In recent years, EHD research has concentrated more on phase-change heat transfer applications. Early results indicate large enhancements for both boiling and condensation heat transfer for certain flow conditions and geometries since significant dielectrophoretic forces can exist due to differences in permittivity of the liquid and vapor. With regard to Naval applications, possible interest in EHD is the enhancement of both boiling and condensation heat transfer when applied to refrigerants, which are dielectrics. These fluids typically exhibit low heat conduction and hence low heat transfer and any augmentation technique needs to be looked at carefully.

2.3.1 Boiling

In boiling, dielectrophoretic forces will tend to move fluids of low permittivity (i.e. vapor bubbles) to areas of low field strength. The electric field strength is weakest in the superheated region close to the heated surface due to an increase in electrical conductivity when compared to the colder saturated bulk fluid. For the case of pool boiling from a horizontal tube with cylindrical electrodes (i.e. using the evaporator shell as one electrode and a smaller concentric wire mesh placed around the heated tube as the other), a vapor bubble will experience a force pushing it toward the tube, causing the bottom to spread out over the heated surface; this induces bubble site activation (incipience) to occur at a lower wall superheat and thereby reduces (and can eliminate completely) the effects of temperature overshoot¹. In addition, instabilities that occur at the vapor/liquid interface due to the electric field cause the bubbles to break up into smaller bubbles; this has the effect of simulating new bubble formation from the heated surface and can lead to significant heat transfer augmentation.

¹ Temperature overshoot is defined as the large reduction in wall superheat that occurs when boiling from a surface is first initiated. It makes up the characteristic shape of the well-known boiling hysteresis loop.

There has been a large amount of recent work done on EHD enhancement of nucleate pool boiling from various geometries using different fluids. For a comprehensive review of the published experimental work on EHD augmented pool boiling heat transfer, the reader is referred to Karayiannis and Allen (1991). This brief summary will concentrate on horizontal smooth and enhanced single tubes and tube bundles using refrigerants (and refrigerant/oil mixtures) as the working medium.

An important consideration in EHD enhancement is the choice of electrode design. In studies concerning pool boiling from horizontal tubes, the favored choice seems to be cylindrical electrodes, such as that used by Winer (1967), Allen and Cooper (1987), Karayiannis et al (1989) and Cooper (1990) (Figure 1). It essentially comprises a copper wire-mesh cylinder placed concentrically around the enhanced tube, insulated from the evaporator shell by 'Tufnol' inserts. For tube bundles, Allen and Cooper (1985) developed the electrode geometry shown in Figure 2. It is made up from a combination of rod and perforated plane electrodes, giving a close approximation (see Figure 3) to the 'ideal' case of the above-mentioned wire-mesh concentric cylinder.

Figure 4 shows data taken by Karayiannis et al (1989) during pool boiling of CFC-114 from a smooth brass tube with water heating on the tube side (tube OD of 19.1 mm, tube length of 0.5 m) using a concentric electrode design with an electrode-to-tube diameter ratio of 2. For zero field potential, they found strong evidence of boiling hysteresis; however, the application of a sufficiently strong d.c. electric field (> 20 kV) completely eliminated any hysteresis effects (even at lower intensity fields (10 kV), the wall superheat at which boiling started was significantly reduced). Their results, however, show minimal enhancement over zero field potential in the nucleate boiling region except at the lowest heat fluxes where about a 20% improvement is seen at a similar wall superheat. These results are in close agreement² to those of Winer (1967) who also found no significant enhancement in the nucleate boiling region for CFC-114. Winer (1967) used a smooth tube of 5.6 mm outside diameter and 25.4 mm in length; he also used a concentric wire-mesh electrode system with an electrode-to-tube diameter ratio of 9.15, significantly higher

² Karayiannis et al (1989) report that there is a significant enhancement shown in Figure 2; however, the present author does not agree with this.

than that of Karayiannis et al (1989). However, this results in only a 5% higher³ electric field strength which may explain the similar results (a higher electric field strength would tend to increase the dielectrophoretic force 'bonding' the bubble to the heated surface, thereby enhancing the heat transfer due to increased agitation of the thermal boundary-layer). In the convection region, Winer (1967) did find that the temperature overshoot decreased as applied field potential was increased, but even at the highest field potential of 25 kV, this overshoot was not completely eliminated. The enhancement in the natural convection region for an applied field strength of 25 kV was about 100%, probably resulting mainly from the electrophoretic component of the body force term due to the single phase nature of the liquid. For the tube in a vertical orientation, Winer (1967) found similar results in both the natural convection and nucleate boiling regions as he did for the tube in a horizontal position.

Allen and Cooper (1987) and Cooper (1990) used the same facility as Karayiannis et al (1989) to study EHD enhancement on a horizontal low integral-fin brass tube (called 'lo-fin') in a pool of CFC-114. Figure 5 shows the data obtained for applied electrode potentials of 0, 10 kV and 27 kV. For zero field potential, a significant temperature overshoot is seen. For either applied electrode potential, complete elimination of boiling hysteresis was obtained; for a smooth tube, Karayiannis et al (1989) only obtained *complete* elimination of hysteresis at the highest applied potential of 20 kV. Cooper (1990) further found that if a sufficiently intense electric field (> 10 kV) was applied to the finned tube in the natural convection region for only a very short duration (< 1 second), then boiling was initiated and remained even when the potential was removed.

In the nucleate boiling region at the highest potential of 27 kV, Allen and Cooper (1987) found an order of magnitude enhancement over zero field potential. This was attributed to modified bubble dynamics of the boiling process yielding significantly smaller bubble departure diameters than for a zero potential field (also noted for a smooth tube). More importantly, the enhancement obtained by applying an electric field to a finned tube was attributed to the strong electric field inhomogeneities at the surface and, in particular, between the fins. This interfin

³ Karayiannis et al (1989) report a 60% higher electric field strength due to an error in their calculation.

region has the lowest field intensity and the largest number of active nucleation sites due to the larger wall superheat. Consequently, the strong dielectrophoretic forces in this region tend to trap the vapor bubbles in the interfin spaces. Forced to eventually rise by buoyancy forces, the bubbles slide around the heated surface and promote turbulent mixing leading to further substantial enhancement; this is similar to the effect of enhanced tube surfaces such as GEWA-T and GEWA-Y which trap vapor in the interfin channels, resulting in a bubble pumping action. This may also help to explain why little or no enhancement was obtained for a smooth tube where any electric field inhomogeneities at the surface are significantly less than those on a finned tube. It should be noted that the heat flux range covered in these experiments was relatively low (200 W/m^2 to 4000 W/m^2), well below the operating heat flux of a typical CFC-114 air-conditioning plant. At a similar heat flux in pure CFC-114, Memory et al (1992c) report a factor of 3 enhancement⁴ in the boiling region for an integrally finned copper tube (26 fpi GEWA-K) when compared to a smooth copper tube with zero field potential; in addition, Memory et al (1992c) reported significant temperature overshoot in this low heat flux region.

Cooper (1990) further investigated the heat-transfer performance of CFC-114/oil mixtures when subjected to an electric field. Figure 6 shows the EHD enhancement of CFC-114 with 10% (by weight) of a miscible mineral oil (Shell Clavus 68). For zero field potential, significant degradation in the heat-transfer coefficient (up to 50%) can be seen (compared with Figure 5). Also, significant foaming was seen, similar to that reported by Wanniarachchi et al (1987) for a mixture of CFC-114 and York-C oil (similarly a miscible mineral oil). At a potential of 23.5 kV (the highest that could be attained due to the reduced insulation properties of the CFC/oil mixture), the heat transfer enhancement due to the electric field with 10% oil reduced to a factor of around 5. However, boiling hysteresis was again eliminated and there was a dramatic reduction in the amount of foaming, the reason for which is not entirely clear. At these low heat fluxes, Memory et al (1992c) reported no significant reduction in boiling enhancement (i.e. still a factor of about 3) at 10% oil concentration when comparing a GEWA-K (26 fpi) copper tube with a smooth copper tube with zero field potential; however, significant foaming was also observed.

⁴ This enhancement is based on using root diameter in the heat flux calculation; it is therefore reduced somewhat if actual finned surface area is used.

In the work of Cooper (1990), the dielectric permittivity of the oil and CFC-114 was (by chance) of similar magnitude. If an oil of significantly different permittivity had been used, further enhancement may have been obtained due to the increased dielectrophoretic mixing that would exist in regions of inhomogeneous oil concentration. It should be noted that all EHD phenomena reported by Cooper (1990) were equally effective for both a.c. and d.c. fields.

Damianidis et al (1992) studied EHD enhancement from a single Thermoexcel-C tube using CFC-114. Thermoexcel-C was designed as a condenser tube and comprises a large number of saw-tooth fins, manufactured quite easily from a low integral-fin tube. Damianidis et al (1992) speculated that the use of such a tube for boiling applications may be advantageous due to the high electric field strength expected at the sharp fin tips. Figure 7 shows a comparison of a single smooth, low integral-fin and Thermoexcel-C tube. For all three tubes, hysteresis effects are completely eliminated for the application of an electric field potential greater than 20 kV. It is also evident that the Thermoexcel-C tube has the highest heat-transfer coefficient at the highest applied field potential, supporting the idea proposed above. Interestingly, for zero applied field, the Thermoexcel-C tube (a *condenser* tube) has a similar boiling performance as the low integral-fin tube and significantly higher than the smooth tube when the latter has a field applied or not.

Recently, Ohadi et al (1992) looked at EHD nucleate boiling augmentation from a smooth copper tube using HCFC-123 and HCFC-123/oil mixtures (HCFC-123 is a proposed replacement refrigerant for CFC-11). Six copper wires, placed 3 mm from the heated surface along the length of the tube (at 60° intervals around the tube) were used as the high voltage electrodes. At a practical heat flux of 27 kW/m² for pure HCFC-123, they reported an enhancement of up to 170% (over zero potential) at the highest applied field of 19 kV. This dropped to about 100% at an oil concentration of 5%. Extensive flow visualization was also carried out and showed that with increases in voltage (above the threshold voltage of 3 kV), the bubble departure diameter decreased while the bubble departure speed increased.

Damianidis et al (1991, 1992) present data for a small horizontal bundle of smooth and low integral-fin tubes in a pool of CFC-114. The bundle contained 9 tubes (heated using hot water) in a 3 x 3 square array and used the electrode system

developed by Allen and Cooper (1985) (Figure 3). The outside diameters of the smooth and low integral-fin tubes were 19.1 mm and 18.6 mm (to the tips of the fins) respectively. Figure 8 shows the data for the smooth tube bundle for applied potentials of 0 and 30 kV. It can be seen that no enhancement is evident, agreeing well with the single smooth tube data of Winer (1967) and Karayiannis et al (1989). Furthermore, hysteresis effects are not eliminated even at the highest applied potential of 30 kV; this is also in agreement with the results of Winer (1967) for a single smooth tube, but in contradiction to those of Karayiannis et al (1989) who reported complete elimination of hysteresis for a single smooth tube at an applied potential of 20 kV.

In contrast, Figure 8 also shows that any applied field potential considerably enhances the mean heat-transfer coefficient for the low integral-fin tube bundle when compared to zero field potential. At a potential of 30 kV, the enhancement is an order of magnitude, similar to that found for a single low integral-fin tube by Allen and Cooper (1987) and Cooper (1990). Furthermore, complete elimination of any temperature overshoot occurs even at the lowest reported potential of 10 kV, again very similar to that found for a single low integral-fin tube. Allen and Cooper (1987) attributed these effects to strong electric field inhomogeneities at the surface of the finned tubes tending to trap the vapor bubbles between the fins and modifying the bubble dynamics.

2.3.2 Condensation

In condensation, the dielectrophoretic forces tend to destabilize the liquid/vapor interface when a nonuniform electric field is applied between the outside condensing surface and a concentric wire-mesh electrode (similar to that used above in boiling studies) placed around it. This can lead to heat transfer augmentation in two ways. Firstly there is a liquid extraction phenomenon from the condensate film, i.e. condensate is 'attracted' to the outer electrode thereby thinning the condensate film. The second occurs on a sufficiently thin condensate film where the destabilization can lead to dry patches on the condensate surface. It has been explained as a *surface granulation* phenomenon with an appearance similar to normal dropwise condensation and, as a consequence, is termed "pseudo-dropwise" condensation although the mechanisms which cause it are quite different. Whereas normal dropwise condensation occurs with fluids of relatively high surface tension,

pseudo-dropwise condensation has also been seen to occur with fluids of low surface tension, i.e. refrigerants. The second augmentation effect is somewhat dependent on the first, which thins the condensate film sufficiently for pseudo-dropwise condensation to occur.

The majority of work done on EHD enhancement with condensation has dealt with flat plates and vertical tubes. Again the reader is referred to Karayiannis and Allen (1991) for a review of published experimental work on EHD augmented condensation heat transfer. This report will concentrate on vertical and horizontal tube configurations which are of most interest to the Navy.

The design of the electrode system for condensation EHD enhancement tends to be more complex than with boiling and there have been numerous designs proposed. The reason for this comes back to the fact that as the electrode attracts the condensate, it must also act as an efficient condensate 'drain'; in a bank of condenser tubes, condensate, once formed, can be a significant problem leading to a significant drop-off in overall performance. For condensation outside vertical tubes, Yabe et al (1987) present a number of different electrode configurations (Figure 9) that have been tried.

Typical enhancements of up to 5 have been obtained by Yabe et al (1986) for condensation of CFC-113 (when compared to a similar situation without an electric field) for a single vertical tube with helical wire electrodes. Yamashita et al (1991) tested a bundle of 102 smooth, vertical, stainless-steel tubes condensing CFC-114. Much work went into the optimisation of the electrode design which resulted in a combination of a helical electrode system (similar to that used by Yabe et al (1986)) to extract most of the condensate from the film and a lattice electrode to disturb the remaining thinned film and 'promote' pseudo-dropwise condensation. Each tube had its own set of electrodes, making the overall design of the condenser very complex. At the highest tested potential of 18 kV, Figure 10 shows that the bundle enhancement over zero field potential was about 6.

There has been limited work done on refrigerant condensation on horizontal tubes. Trommelmans and Berghmans (1986) took condensation data on a smooth horizontal copper tube (OD of 18 mm and length of 1.1 m) using CFC-11, CFC-113 and CFC-114 as the working fluids. A copper wire electrode was wound spirally and

placed concentrically around the test tube at a diameter of 38 mm. It was isolated from the grounded tube by PTFE rings. Voltage potentials of 0, 20, 25 and 30 kV were used. The wall temperature was determined by measuring the electric resistance of the test tube. Figure 11 shows the data for CFC-114 giving the measured value of the heat-transfer coefficient (with associated error bands) for each potential. It can be seen that the enhancement obtained is only about 10%, indicating that the liquid extraction phenomenon, found to be so important in vertical condenser augmentation (where it can run off down the electrodes leaving the heated surface with a thinner film), is of less significance with a horizontal tube.

Damianidis et al (1991) tested a horizontal 3×3 smooth tube bundle using the same electrode system developed by Allen and Cooper (1985) and used for the boiling bundle mentioned above. Figure 12 shows that at a potential of 25 kV, the bundle enhancement over zero applied field is only about 10%, i.e. similar to that found by Trommelmans and Berghmans (1986) for a single tube. Damianidis et al (1991) inferred that there was no 'spraying-off' of the condensate film and that flooding of the lower tubes nullified any advantage gained from destabilization of the condensate film caused by the electric field.

2.4 Feasibility of EHD Enhancement for Naval Applications

Ohadi (1991) gives a number of general advantages and limitations of the EHD technique. These will now be discussed with phase-change applications in mind with particular emphasis as to whether EHD enhancement is a practical technique for use by the Navy.

Present shipboard evaporators and condensers use enhanced surfaces as a passive heat-transfer augmentation technique. Evaporators have recently progressed from using low integral-fin tubes to porous coated tubes to increase the nucleation site density, whereas condensers still use finned tubing. EHD is an added augmentation process, applying an extra force in the governing hydrodynamical equations. Consequently, there is no doubt that the required heat load could be handled by this technique. Of more importance here are the practical, economic and safety related considerations.

One of the first questions that should be asked is one of reliability. EHD enhancement is an active technique and will therefore be less reliable than a passive technique, such as an enhanced tube surface. However, if this method is to be applied in conjunction with an enhanced surface (as has been done with pool boiling from a low integral-fin tube by Cooper (1990)), then a failure of the electrode system would simply reduce the boiling/condensing coefficients back to their original passive values. However, one of the reasons for using any enhancement technique is that it allows a reduction in the size and weight of present systems. Thus if an evaporator were designed with EHD enhancement in mind, then it would presumably be a smaller system; if the enhancement technique failed, there is no guarantee that there would then be sufficient cooling capacity.

Compared with other active techniques (such as rotation, vibration etc), Ohadi (1991) claims that EHD is mechanically less complex, requiring only a small transformer and simple wire or plate electrodes. Furthermore, the increase in pressure drop due to the presence of the electrodes (often only a fine wire) is claimed to be smaller than other active and/or passive techniques. For phase-change applications on single tubes, a simple electrode system may well be sufficient with little pressure drop penalty. However, for large multi-tube evaporators and condensers, it seems that a separate electrode would be needed for each tube, making the system complex and, more importantly, very expensive. For example, the vertical condenser tube bundle tested by Yamashita et al (1991) has a very complex electrode system. In addition, the shell-side pressure drop might now become a significant factor.

The energy requirements with active augmentation techniques are often a significant fraction of the total power used in pumping the fluid. In contrast, even though the voltages involved are very high (order of kV), the power consumed by the EHD technique is only a few watts due to the very small currents involved (1 mA or less). Of course, safety aspects must also be considered with high voltages in a seawater environment. However, due to these small currents, Ohadi (1991) indicates that the hazard from EHD fields is, in fact, smaller than that of normal, low voltage, household supplies. In addition, the risk of electric shock is minimal because all live parts are either completely immersed in the dielectric fluid (and consequently out of reach) or easily insulated. Indeed, with the Navy actively

pursuing a broad-based R & D program⁵ based on electric ship propulsion, integrated electrical and control systems and a systems-engineered approach to development of auxiliary systems, EHD enhanced refrigeration might well be compatible with the developing architecture and represent a desirable element of the program.

One of the most useful advantages of using electric fields as an enhancement technique is their rapid control response i.e. the magnitude of the enhancement can be quickly and effectively controlled (within milliseconds) by adjusting the applied electric field. Furthermore, installation and maintenance would be no more difficult than any other active technique; however, since present shipboard condensers and evaporators use only passive enhancement mechanisms, introduction of such an active technique may lead to increased maintenance and installation costs.

No researchers have reported any adverse effects of the electric field on the chemical composition of the working fluid i.e. the technique appears to be chemically inert. Furthermore, no increased fouling characteristics of the heat transfer surface have been reported. Regarding the alternative refrigerants being considered by the HVAC industry, recent data by Sunada et al (1991) for condensation of HCFC-123 and Ohadi et al (1992) for pool boiling of HCFC-123 indicate enhancements of similar magnitude to those obtained with CFCs. No data have been reported for HCFC-124. It should be mentioned that for fluids with high electrical conductivity (such as water), the power consumption and manufacturing costs required to obtain similar enhancements as that obtained with dielectrics are significantly higher and may limit the use of the EHD technique to refrigeration systems.

In summary, it appears that there are certain advantages to be gained from applying the EHD principle to refrigerant evaporators and condensers. Apart from the significant increases reported in the heat-transfer coefficient, one of the biggest advantages may well be the rapid control of the enhancement by varying the electric field strength. Obviously more research is needed, especially in applying the technique to evaporator and condenser bundles and the electrode systems that would be needed. Limited research on a vertical condenser bundle has led to

⁵ Advanced Ship Machinery Systems (ASMS) Program, formerly the Integrated Electric Drive Program.

significant enhancements (up to a factor of 6 for CFC-114 - Yamashita et al (1991)). However, limited data taken on a horizontal condenser bundle, indicate that EHD techniques do not enhance the heat transfer by any significant amount, probably due to condensate that is expelled from one tube dripping from the electrodes onto lower tubes, resulting in a similar detrimental effect as that obtained with condensate inundation. Of course, shipboard refrigerant condensers, although horizontal at present, could be oriented in a vertical or inclined position in future designs.

In an evaporator bundle, research needs to be done on applying an electric field to a porous surface. It is not clear whether the large enhancements, already obtained with a porous tube with zero potential, can be further improved by application of an electric field. If not, then there will be little benefit to be had if the enhancement obtained on a finned tube with an electric field is still below the enhancement obtained with a porous surface with no field applied. It should be noted that a finned surface lends itself to large enhancements with an electric field due to regions of weak field intensity in the interfin spaces. On a porous tube, such 'interfin' regions do not exist and such large enhancements might not be obtainable. Indeed, a porous surface is more akin to a smooth surface, results from which have indicated little or no enhancement in the presence of an electric field.

From a practical standpoint, therefore, EHD enhancement is certainly feasible for Naval applications and could lead to significant increases in the efficiency of present refrigerant evaporators/condensers. Preliminary research also indicates that such a technique would be just as effective with the alternative refrigerants being proposed for use by the Navy. Areas of uncertainty that need to be researched further include bundle operation (both evaporators and condensers) and the added enhancement (if any) on already highly enhanced surfaces. In addition, effective electrode systems need to be designed for both evaporator and condenser bundles. For the vertical condenser of Yamashita et al (1991), the electrode system seems very complex and this is certainly an area that needs careful consideration in the future. From an economic standpoint, however, EHD enhancement is more uncertain as it is unclear what the cost of this needed research will be.

3. THERMOACOUSTIC REFRIGERATION

3.1 Introduction

With regard to the problems introduced by the use of CFCs, chemical companies have not completely abandoned the vapor-compression cycle as a means of refrigeration. Some have reconsidered fluids that were in use before the age of CFCs such as ammonia, carbon dioxide and even water. There has also been a rush to develop alternative fluids which are more friendly to the ozone, such as HCFCs and HFCs. However, the testing of these fluids and their long-term effects are still in the early stages; indeed, some have already exhibited compatibility problems with lubricants and some (HCFC-123 to name one) have recently been found to be potentially carcinogenic.

As well as alternative refrigerant research, there are also a number of alternative refrigeration technologies that are now being considered (i.e. moving away from the vapor-compression cycle completely). Some of these alternative technologies, and their possible impact on Navy applications, have been covered in a report by Gilmour (1990). They include such concepts as absorption, air cycle, magnetic, Malone cycle, Stirling cycle, thermoacoustic and thermoelectric. Whilst some of these units are commercially available (e.g. absorption plants), the remainder are either only available for specialized applications or still in the laboratory development stage; thermoacoustic refrigeration is still in this latter stage. This report explains the principles behind thermoacoustic refrigeration in more detail, gives up-to-date research information and details the work needed to bring this technology to practical use within the Navy.

3.2 Basic Thermodynamic Concepts

3.2.1 Heat Engines

There are two basic types of heat engine, a prime mover, where heat flows from a high to low temperature and the engine converts a portion of that heat to work (such as an internal combustion engine) and a heat pump, where the flows of work and heat are reversed (i.e. work done on the engine causes it to pump heat from a low to high temperature, such as a household refrigerator). The first and second

laws of thermodynamics place an upper limit on the efficiency of a prime mover (the fraction of heat converted to work) and the coefficient of performance (COP) of a heat pump (the amount of heat rejected at the higher temperature per unit of work). For a thermodynamically reversible cycle (i.e. one in which all parts of the system are always in thermodynamic equilibrium), the efficiency and COP are equal to this upper limit, which depends only on the temperatures involved.

The Carnot cycle is the most fundamental engine cycle operating across a temperature differential. It is thermodynamically reversible, consisting of alternating adiabatic (i.e. no heat flow occurs) and isothermal (i.e. the temperature remains constant) steps. Over a complete cycle, no entropy is generated and the Carnot cycle therefore represents the theoretical upper efficiency limit of a heat engine, usually called the Carnot efficiency.

The differences between an ideal cycle of a heat engine and those found in reality are due to irreversible processes caused by temperature and pressure gradients. These generate entropy and cause a loss of efficiency. One may approach near equilibrium conditions by obviously designing the engine so as to reduce these gradients. However, the result is a very slow cycling of the engine and a very low power output. Real high-speed reciprocating engines cannot approach Carnot efficiency.

To give an example, the household refrigerator is based on the vapor-compression or Rankine cycle which duplicates a portion of the Carnot cycle by having one adiabatic step (compression) and two isothermal steps (evaporation and condensation); the 4th step in an isenthalpic expansion through a throttling valve. The two isothermal steps involve phase change of the working fluid, which is forced around a closed loop as a continuous flow rather than by reciprocation. The cycle, however, has intrinsic irreversibilities associated with the free expansion of the liquid (from the condenser) and the cooling of the vapor to the temperature at which condensation occurs. There are also losses due to temperature differences in the heat exchangers and motor/compressor inefficiencies which lead to a COP less than Carnot. Gilmour (1990) states that for shipboard air conditioning plants, where chilled water is required at 44 °F and heat rejection is to seawater at 88 °F, the ideal Carnot COP is 11.45. Due to the irreversibilities mentioned above, shipboard plants operate at a COP of 4.7, i.e. only 41% of Carnot efficiency at the specified temperatures. Despite this, Rankine engines remain the design of choice in many

applications as they are simple, relatively cheap, reliable and powerful. When designing real heat engines, therefore, whether they be prime movers or heat pumps, the aim is not necessarily to reduce these irreversibilities, but to balance cost, efficiency, size, power, reliability and simplicity to the needs of a particular application.

3.2.2 Thermoacoustic Engines

Although in practical heat engines, irreversibilities are often deliberately introduced to increase power, simplify design and reduce cost (at the expense of efficiency), ideal heat engine cycles are intrinsically reversible (i.e. irreversibilities are minimized because they generate entropy and decrease efficiency). On the other hand, natural engines (i.e. those which have no moving parts and are therefore very simple) are intrinsically irreversible (i.e. they cannot work if irreversibilities are eliminated). A thermoacoustic engine is an example of a natural engine; it can be both a prime mover, where heat flow from a high-temperature source to a low-temperature sink (room temperature) generates acoustic power (which may be converted to electric power using a transducer), or a heat pump, where acoustic power is used to pump heat from a low-temperature source to a high temperature sink (refrigeration). Combining the two leads to the idea of a heat-driven thermoacoustic refrigerator.

One of the first demonstration machines built to demonstrate the simplicity of a heat-driven refrigerator was by Swift (1988) at the Los Alamos National Laboratory (Figure 13). Known as the 'beer cooler', it was comprised of a long tube, closed at one end and opening into a large spherical bulb at the other end, containing helium at 3 bar. Near the closed end (the prime mover), there was a stack of stainless-steel plates aligned parallel to the tube axis and two sets of heat exchange strips, one made of nickel and kept at a hot temperature (by heating) and the other made of copper and kept at room temperature by cooling water. When the temperature difference across the stack is large enough, the helium gas oscillates at about 580 Hz. Thus this upper stack operates as a prime mover and produces acoustic work from applied heat. Below the prime mover there is another identical stack of parallel plates with a pair of heat exchangers, both made of copper. The upper heat exchanger is maintained at room temperature; when the temperature of the hot (prime mover) heat exchanger is high enough, the helium gas oscillates and the cold heat exchanger cools to below 0 °C. These, then, operate as a heat pump, driven by the

acoustic work generated by the prime mover stack. The whole system operates as a refrigerator with no moving parts, powered by heat delivered at high temperature.

The heart of a thermoacoustic engine is the stack of plates. To illustrate the basic mechanisms occurring within the stack more clearly, it is worthwhile to study the simpler case of a fluid supporting a plane standing wave⁶ passing parallel to a single solid plate where the acoustic and thermodynamic effects are nearly distinct. It should be noted here that an acoustic standing wave on its own has no interesting thermodynamic phenomena apart from the adiabatic temperature oscillations that accompany the pressure oscillations at the nodes and antinodes of the wave. However, the introduction of a stationary plate, which imposes an isothermal boundary on the fluid, changes this dramatically. Essentially, the thermal interaction of the wave and the plate stimulates not only a heat flux along the plate (about a thermal penetration depth away from the plate⁷), but also a generation or absorption of acoustic power by the fluid near the plate. These two interactions constitute the timed phasing of the thermodynamic processes (performed by the precise timing of pistons and valves in a traditional internal combustion engine), and yield the desired thermodynamic cycle of a heat engine. It is the temperature gradient of the plate, therefore, which determines whether the heat engine is a prime mover or heat pump.

The basic thermodynamic cycle consists of two reversible adiabatic steps (compression and expansion of the gas) and two irreversible constant pressure steps (transfer of heat to or from the plate); this cycle is identical to the Brayton cycle. As the fluid oscillates along the plate, it experiences changes in temperature due not only to the adiabatic expansion or compression of the fluid by the sound pressure but also to the local temperature of the plate itself. It is the fact that the flow of heat between the two media (fluid and plate) has an inherent time delay and is not instantaneous that creates the time phasing needed to drive the fluid through the thermodynamic cycle. Thus a simple, but irreversible process (flow across a temperature gradient) is intrinsic to the operation of thermoacoustic engines. In

⁶ A standing wave is one which is fixed in position longitudinally with a fluctuating amplitude. Its nodes always remain at rest whereas the antinodes (midway between the nodes) have maximum fluctuation.

⁷ The thermal penetration depth represents the distance over which heat will diffuse during a time which is of the order of an acoustic period ($T = 1/f$), where f is the acoustic frequency.

other words, a parcel of fluid within the thermal penetration depth of the plate⁸ has good enough thermal contact to exchange some heat with the plate, but at the same time has poor enough contact to produce the time delay required for proper phasing of the temperature oscillations of the working fluid.

Figure 14 shows the four steps of the thermoacoustic cycle. During the compressional part of the acoustic standing wave (step 1) a gas parcel (initially at T) is both warmed (by an amount T_1) and displaced along the plate (by a distance x_1) towards the pressure antinode of the wave. The temperature of the plate at the location of the displaced gas parcel ($T + x_1\Delta T$) depends on the temperature gradient (ΔT) applied to the plate. Therefore, whether heat passes from gas to plate or vice-versa depends on the size of the applied temperature gradient. If this applied gradient is low, then the compressed gas parcel temperature is higher than the plate temperature and heat is transferred from parcel to plate by an amount δT (step 2); this is the mode of operation for a heat pump, and the reverse is true for a prime mover. Therefore, the operation of the thermoacoustic engine as a prime mover or heat pump is simply due to the temperature gradient applied, which can be maintained by heat sinks and sources (heat exchangers) placed at either end of the plate. Note that if the temperature gradient along the plate just matches the temperature change due to the adiabatic compression, then no heat would flow. This temperature gradient which separates the two modes of operation is called the critical temperature gradient.

The expansion part of the cycle (step 3) causes a cooling and equal displacement back along the plate. The gas parcel is now colder than the adjoining wall by an amount δT (the expansion and compression steps are reversible) and therefore an amount of heat equal to δT passes from the wall to the gas parcel (step 4). The cycle is then repeated. The acoustic engine can therefore be thought of as having a long train of adjacent gas parcels, all within a thermal penetration depth of the plate, that each draw heat from the plate at one extreme of their oscillatory motion and deposit heat at the other extreme. The net result is that an amount of heat is passed from one end of the plate to the other in the direction of the pressure antinode (Figure 15); the plate itself is used only as a temporary storage of heat. However, at the ends of the

⁸ At greater distances than a thermal penetration depth from the plate, the gas parcels have no thermal contact with the plate and are simply compressed or expanded by the standing wave.

plate, thermodynamic symmetry is broken and the gas parcels idle through part of their cycle (the part that takes them more than a thermal penetration depth away from the plate) resulting in a net heating or cooling of the plate at either end. This flow of heat from one end to the other can be taken advantage of by bringing heat exchangers into contact with both ends of the plate.

3.3 Thermoacoustic Refrigerator

The above discussion describes the basic principles behind thermoacoustic engines and the differences between prime movers and heat pumps. We now concentrate on the latter and give details of how acoustic work (provided from a loudspeaker) has been used to pump heat from a low temperature to a high temperature i.e. thermoacoustic refrigeration. Hofler (1986) designed and tested a thermoacoustic refrigerator (called a cryocooler - Figure 16) which consisted of a helium filled resonator at 10 bar, driven by a loudspeaker, containing a stack of plates with one end at room temperature. The shape of the cryocooler was such that losses in the cold part of the resonator were minimized, thus reducing any unnecessary thermal loads on the refrigerator.

The stack was made from plastic sheet spirally wound around a plastic rod giving a 3.8 cm diameter stack 8 cm long. The individual layers of plastic were kept approximately four thermal penetration depths apart by well-spaced segments of nylon fish line glued to the sheet along the direction of acoustic oscillation. The two heat exchangers at either end of the stack were made of copper strips reaching across the diameter of the stack and making excellent thermal contact with the resonator walls. The 'hot' heat exchanger was kept at room temperature by water cooled coils attached to the outside of the resonator. The cold heat exchanger was thinner than the hot end due to the greater acoustic velocities in this region (being closer to a velocity antinode and pressure node), thus reducing the viscous losses.

The measured performance of the thermoacoustic refrigerator is shown in Figure 17 where the cold temperature (normalized by room temperature) and the COP (normalized by Carnot COP) are plotted against the thermal load applied to the cold end for various pressure amplitudes. COP here is given by the thermal load applied divided by the power delivered by the loudspeaker. It can be seen that the thermal loads applied and the Carnot efficiencies obtained are relatively small. However,

these low values, together with the fact that there are no moving parts, make the thermoacoustic refrigerator ideal for certain tasks where heat loads are small and maintenance is limited e.g. space applications.

The first attempt to commercially exploit the advantages of the thermoacoustic heat engine for space applications was a cryocooler called the space thermoacoustic refrigerator (STAR), where the requirements are very little heat pumping power (a few Watts) over a very large temperature span (100 to 200 K). It was very similar in size and shape to the thermoacoustic refrigerator designed by Hofler (1986). The performance of the STAR provided a maximum Carnot COP of 16% with a 3 W thermal load applied to the cooled end. However, Garrett and Hofler (1991) indicate that improvements to the design (and especially the stack) could lead to a significant reduction in the viscous losses and a consequent increase in the Carnot COP.

The STAR is only the first in a series of similar cryocoolers now under development at the Naval Postgraduate School. Unfortunately, requirements for shipboard air conditioning systems are directly opposite to those for space applications, requiring modest temperature spans (25 to 45 K) at much higher heat pumping powers (kilowatts). Garrett and Hofler (1991) admit that several design modifications would be needed to adapt from a space cryocooler to a commercial AC system, but state that none of these modifications should present substantial technological barriers. Indeed, they show a schematic of a proposed half-ton capacity thermoacoustic chiller (Figure 18) with a $1/2$ wavelength resonator (as opposed to a $1/4$ wavelength resonator used in the STAR) operating at 60 Hz and powered by a single double-acting electrodynamic driver. Using two stacks instead of one would reduce the required heat pumping capacity of each individual stack. The stacks shown in Figure 18 have diameters of 18 cm, and the whole device is 90 cm wide, 60 cm tall and 20 cm thick. Garrett and Hofler (1991) claim that it should be capable of pumping about 2 kW of heat across a 30 K temperature span with a COP of 3-4 (about 30% of Carnot). They go on to say that the greatest uncertainty in the use of thermoacoustic engines in high power cooling applications is the design of the heat exchangers.

3.4 Feasibility of Thermoacoustic Refrigeration for Naval Applications

Gilmour (1990) lists eight criteria that new shipboard AC systems must meet:

- More efficient than existing plants (0.75 kW/ton)
- Lower weight/ton than existing plants (86 lb/ton wet weight)
- Less volume/ton than existing plants (1.75 ft³/ton volume)
- Cost effective
- Lower noise and vibration than existing plants
- Simple operation and maintenance
- No ozone depleting chemicals
- Safe in a shipboard environment

At present, the first three of these clearly cannot be met (once installed, the operating cost would probably be significantly lower than existing plants). However, great advances have been made in the past decade in our understanding of thermoacoustic engines such that in the future (maybe within the next 10 years), it should be feasible to design a thermoacoustic chiller with a capacity of kilowatts such that it meets criteria 1-3; the remaining criteria are already met by present low power systems and apart from possible increases in noise and vibration, the author sees no reason why future high power systems shouldn't also meet the above criteria. Based on knowledge gained from present low power systems (which typically use gas Mach numbers of around 0.1), noise and vibration is very low, which may seem surprising since it is an acoustic system. A unit of a few kilowatts would need gas Mach numbers approaching 0.3, thereby increasing the noise and vibration levels; however, at this stage it is not known how this would compare with noise and vibration levels of present chiller units.

In summary, therefore, it is clear that the thermoacoustic refrigerator is still in the very early developmental stages. However, its general principles of operation have been proven for small thermal loads. The largest ships can require chiller units with up to 360 tons capacity. However, due to the probable small size of the thermoacoustic chiller, it is not unreasonable to think of independent thermoacoustic chillers throughout the ship, each one providing a few tons of cooling for specific areas or applications on the ship. If this were the case, then thermoacoustic refrigeration might also be compatible with the goals of the

Advanced Ship Machinery Systems Program. The present capacity and efficiency limitations of the thermoacoustic chiller are not seen as a problem in the long term. The biggest problems that face development of such a unit, therefore, are not technological, but financial, i.e. is interest high enough to provide the necessary funds to carry out the required research.

4. ACKNOWLEDGEMENTS

The author would like to thank Professor Paul Marto, Professor Charles Calvano and Dr. Tom Hofler for making many useful suggestions throughout the writing of this report.

5. REFERENCES

- Allen, P.H.G. and Cooper, P. (1985), "Improvements in or Relating to Heat Exchangers", UK Patent No. 8522680.
- Allen, P.H.G. and Cooper, P. (1987), "The Potential of Electrically Enhanced Evaporators", Proc. 3rd Int. Symp. on the Large Scale Application of Heat Pumps, pp. 221-229.
- Cooper, P. (1990), "EHD Enhancement of Nucleate Boiling", J. Heat Transfer, Vol 112, pp. 458-464.
- Damianidis, C., Collins, M. W., Karayiannis, T. G. and Allen, P.H.G. (1991), "EHD Enhancement of Heat Transfer in Evaporators and Condensers", 11th Symposium of Heating, Refrigerating and Air Conditioning, Interklima 91, Zagreb, Yugoslavia, pp. 10-26.
- Damianidis, C., Karayiannis, T. G., Al-Dadah, R. K., James, R. W., Collins, M. W. and Allen, P.H.G. (1992), "EHD Boiling Enhancement in Shell and Tube Evaporators and Its Application in Refrigeration Plants", Int. Symp. on Recent Advances in Augmentation of Single-Phase and Phase-Change Heat Transfer, ASHRAE Summer Annual Meeting, Baltimore.
- Garrett, S. L. and Hofler, T. J. (1991), "Thermoacoustic Refrigeration", Technology 2001: The Second National Technology Transfer Conference and Exposition, San Jose, CA.
- Gilmour, T. A. (1990), "Alternative Non-Vapor Compression Air Conditioning Concepts", DTRC Report No. DTRC-PAS-90/32.
- Hofler, T. (1986), "Thermoacoustic Refrigerator Design and Performance", Ph.D., University of California at San Diego.
- Jones, T. B. (1978), "Electrohydrodynamically Enhanced Heat Transfer in Liquids - A Review", Advances in Heat Transfer, Vol. 14, pp. 107-148.
- Karayiannis, T. G., Collins, M. W. and Allen, P. H. G. (1989), "Electrohydrodynamic Enhancement of Nucleate Boiling Heat Transfer in Heat Exchangers", Heat and Technology, Vol. 7, No. 2, pp. 36-41.

Karayiannis, T. G. and Allen, P. H. G. (1991), "Electrohydrodynamic Enhancement of Two-Phase Heat Transfer", Eurotech Direct, Paper No. C413/036, Birmingham, UK.

Kronig, R. and Ahsmann, G., (1949), "the Influence of an Electric Field on the Convective Heat Transfer in Liquids", Appl. Sci. Res. Sect., A2, pp31-32.

Landau, L.D. and Lifshitz, E. M. (1963), *Electrodynamics in Continuous Media*, Pergamon, New York, p. 68.

Memory, S. B., Mazzone, R. W. and Marto, P. J. (1992a), "Enhanced Laminar Film Condensation of R-113 Using Wire-Wrap on a Horizontal Roped Tube Bundle", submitted to the 3rd UK National and 1st European Heat Transfer Conference, Birmingham, UK.

Memory, S. B., Chilman, S. V. and Marto, P. J. (1992b), "Nucleate Boiling Characteristics of a Small Enhanced Tube Bundle in a Pool of R-113", submitted to the National Heat Transfer Conference, San Diego.

Memory, S. B., Sugiyama, D. C. and Marto, P. J. (1992c), "Nucleate Pool Boiling of R-114 and R-114/Oil Mixtures From Smooth and Commercial Enhanced Surfaces: Part I - Single Tubes", to be submitted to the Journal of Heat Transfer.

Memory, S. B., Akcasayar, N., Eraydin, H. and Marto, P. J. (1992d), "Nucleate Pool Boiling of R-114 and R-114/Oil Mixtures From Smooth and Commercial Enhanced Surfaces: Part II - Small Tube Bundles", to be submitted to the Journal of Heat Transfer.

Ohadi, M. M. (1991), "Heat Transfer Enhancement in Heat Exchangers", ASHRAE Journal, December.

Ohadi, M. M., Papar, R.A., Ansari, A.I. and Kumar, A. (1992), "Some Observations on EHD-Enhanced Boiling of R-123 in the Presence of Oil Contamination", Presented at 'Pool and External Flow Boiling', Mar 23-27, Santa Barbara.

Sunada, K., Yabe, A., Taketani, T. and Yoshizawa, Y. (1991), "Experimental Study of EHD Pseudo-Dropwise Condensation", Proc. 3rd ASME/JSME Thermal Engineering Joint Conference, Reno, Vol. 3, pp. 47-53.

Swift, G. W. (1988), "Thermoacoustic Engines", *J. Acoust. Soc. Am.*, Vol. 84, No. 4, pp. 1145-1180.

Trommelmans, J. and Berghmans, J. (1986), "Influence of Electric Fields on Condensation Heat Transfer of Nonconducting Fluids on Horizontal Tubes", *Proc. 8th Int. Heat Transfer Conf.*, San Francisco, Vol. 6, pp. 2969-2974.

Wanniarachchi, A. S., Sawyer, L. M. and Marto, P. J. (1987), "Effect of Oil on Pool Boiling Performance of R-114 From Enhanced Surfaces", *Proc. 2nd ASME/JSME Thermal Engineering Joint Conference*, Honolulu, Hawaii, Vol. 1, pp. 531-537.

Wheatley, J. C., Swift, G. W. and Migliori, A. (1986), "The Natural Heat Engine", *Los Alamos Science*, No. 14, pp. 2-29.

Winer, M. (1967), "An Experimental Study of the Influence of a Nonuniform Electric Field on Heat Transfer in a Dielectric Fluid", *TRW Systems Report*, Report No. EM17-14

Yabe, A., Taketani, T., Kikuchi, K., Mori, Y. and Maki, H. (1986), "Augmentation of Condensation Heat Transfer by Applying Electro-Hydro-Dynamical Pseudo-Dropwise Condensation", *Proc. 8th Int. Heat Transfer Conf.*, San Francisco, Vol. 6, pp. 2957-2962.

Yabe, A., Taketani, T., Kikuchi, K., Mori, Y. and Hijikata, K. (1987), "Augmentation of Condensation Heat Transfer Around Vertical Cooled Tubes Provided With Helical Wire Electrodes by Applying Nonuniform Electric Fields", *Heat Transfer Science and Technology*, Bu-Xuan Wang, ed., Washington D.C., Hemisphere, pp. 812-819.

Yamashita, K., Kumagai, M., Sekita, S., Yabe, A., Taketani, T. and Kikuchi, K. (1991), "Heat Transfer Characteristics on an EHD Condenser", *Proc. 3rd ASME/JSME Thermal Engineering Joint Conference*, Reno, Vol. 3, pp. 61-67.

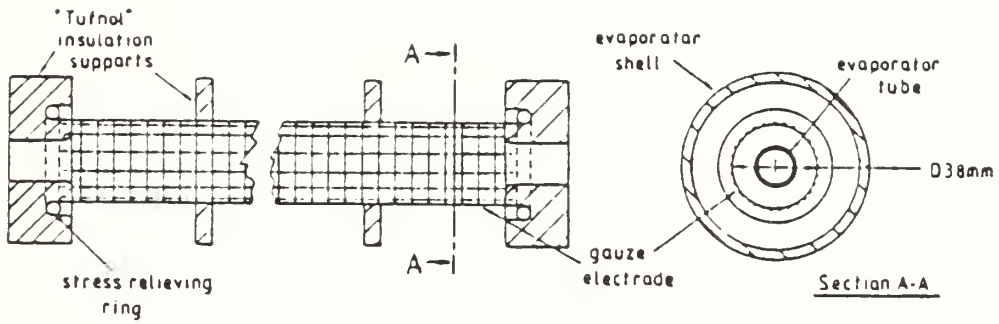

Figure 1: Cylindrical Electrode System (from Cooper et al (1990))

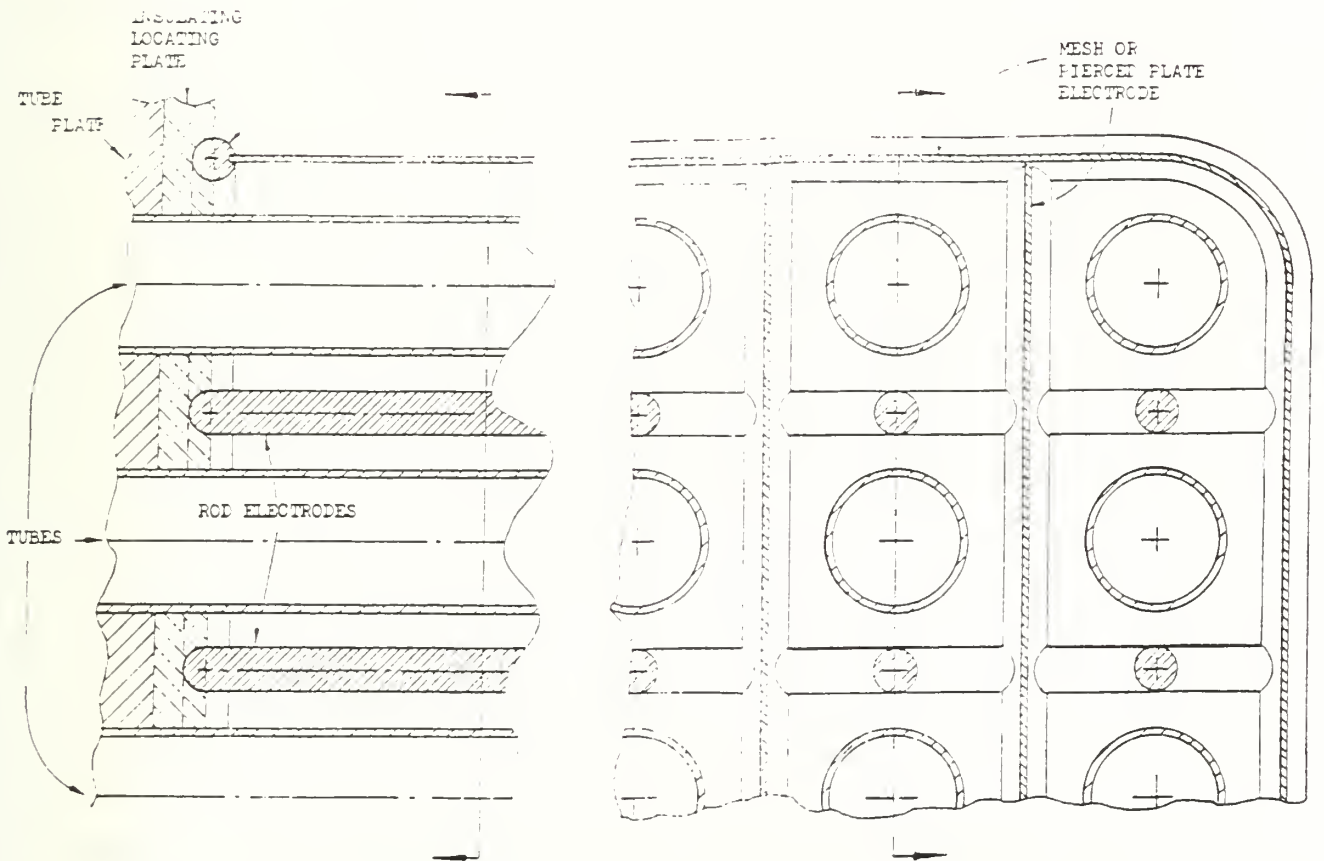

Figure 2: Electrode System for Evaporator/Condenser Tube Bundle (3 x 3) (from Allen and Cooper (1985))

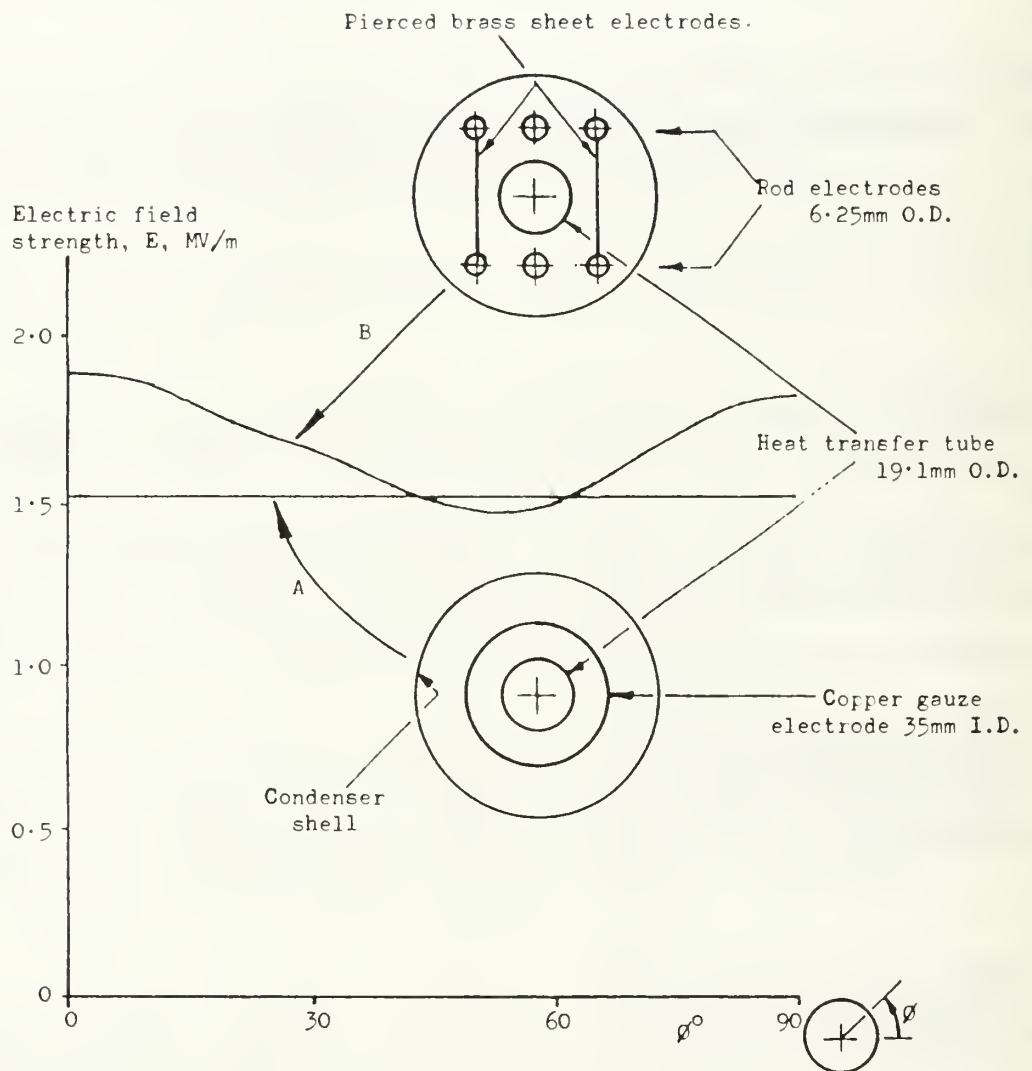

Figure 3: Distribution of Electric Field Strength Normal to Heat Transfer Surface for 'Ideal' Coaxial Cylindrical Electrode and Optimised Rod and Plane Electrode (from Karayiannis and Allen (1991))

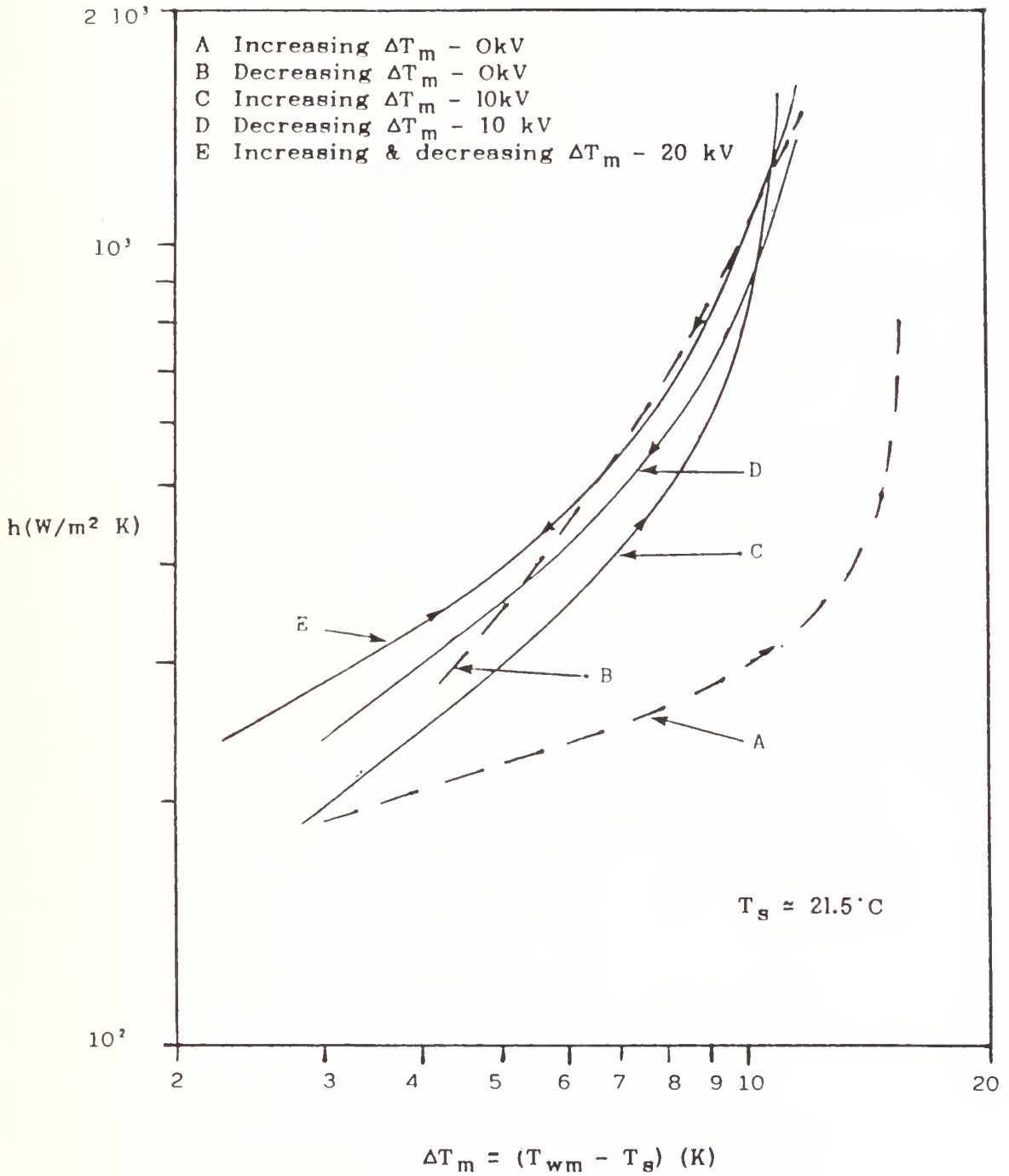

Figure 4: EHD Enhancement for Boiling Heat Transfer from a Single Smooth Tube in a Pool of CFC-114 (from Karayiannis et al (1989))

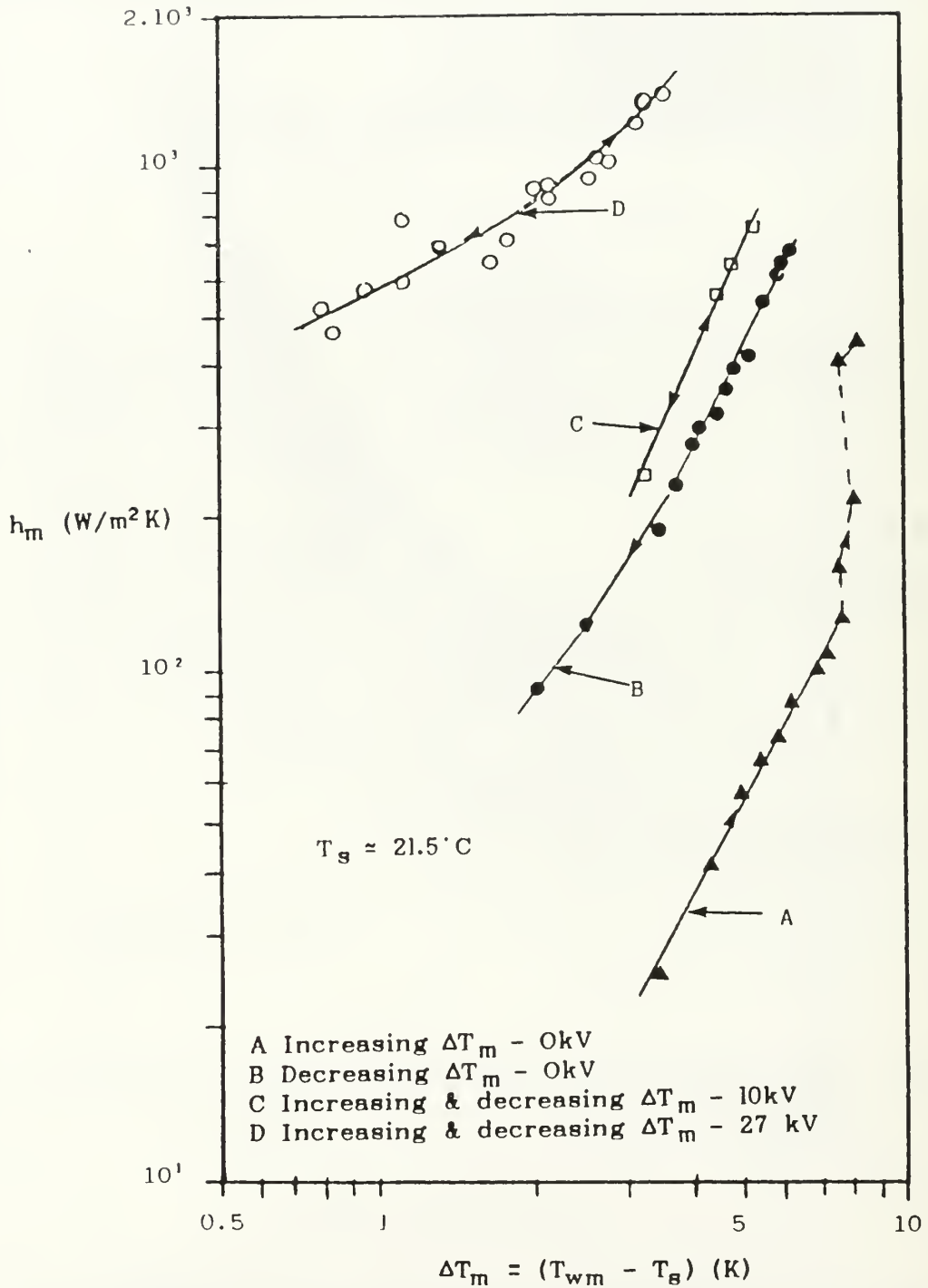

Figure 5: EHD Enhancement for Boiling Heat Transfer from a Single Low Integral-Fin Tube in a Pool of CFC-114 (from Allen and Cooper (1987))

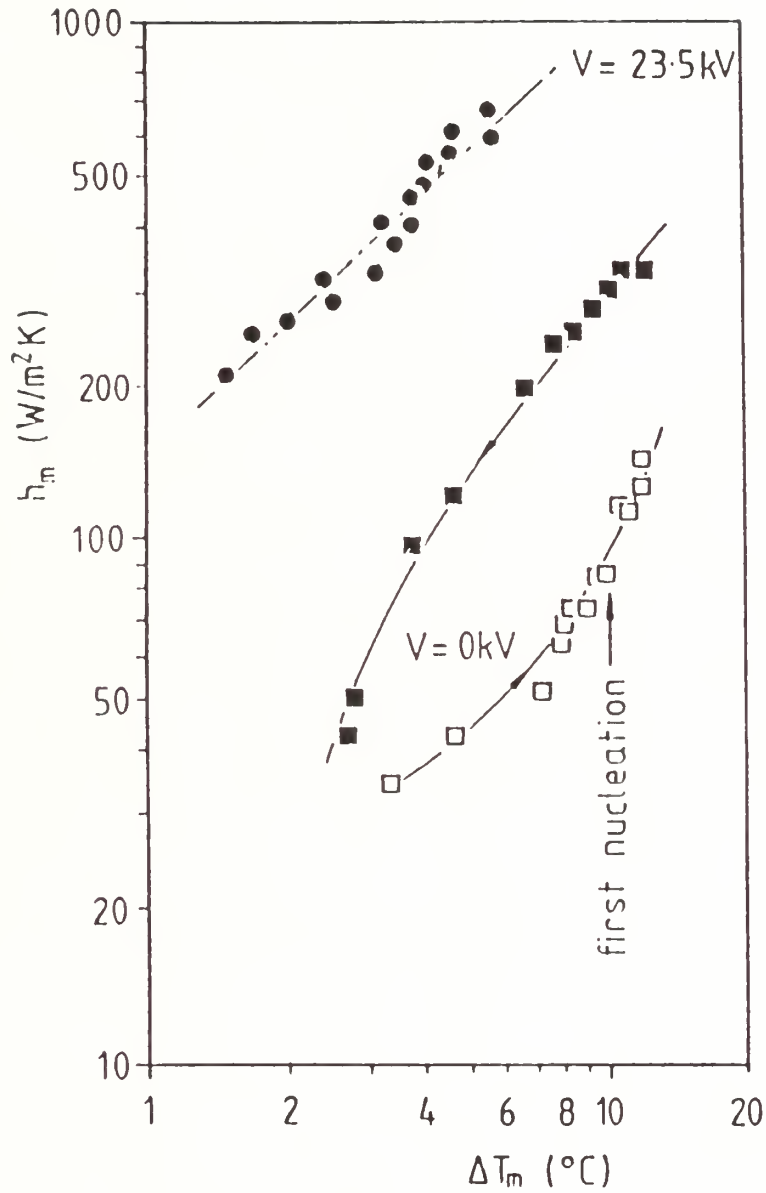

Figure 6: EHD Enhancement for Boiling Heat Transfer from a Low Integral-Fin Tube in a Pool of CFC-114/Oil (10%) Mixture (from Cooper (1990))

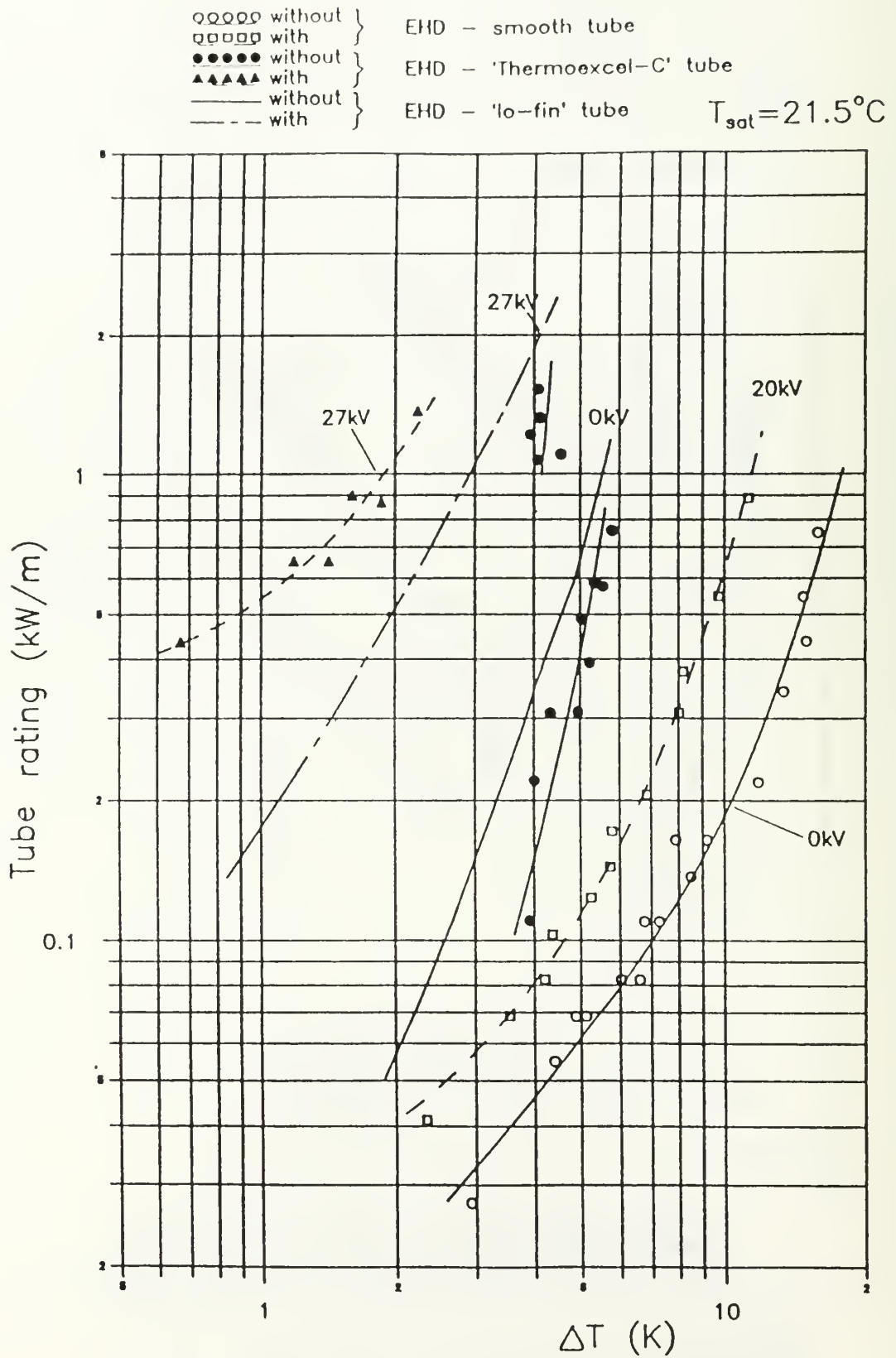

Figure 7: Comparison of EHD Enhancements for Boiling Heat Transfer from a Single Smooth, Low Integral-Fin and Thermoexcel-C Tube in a Pool of CFC-114 (from Damianidis et al (1992))

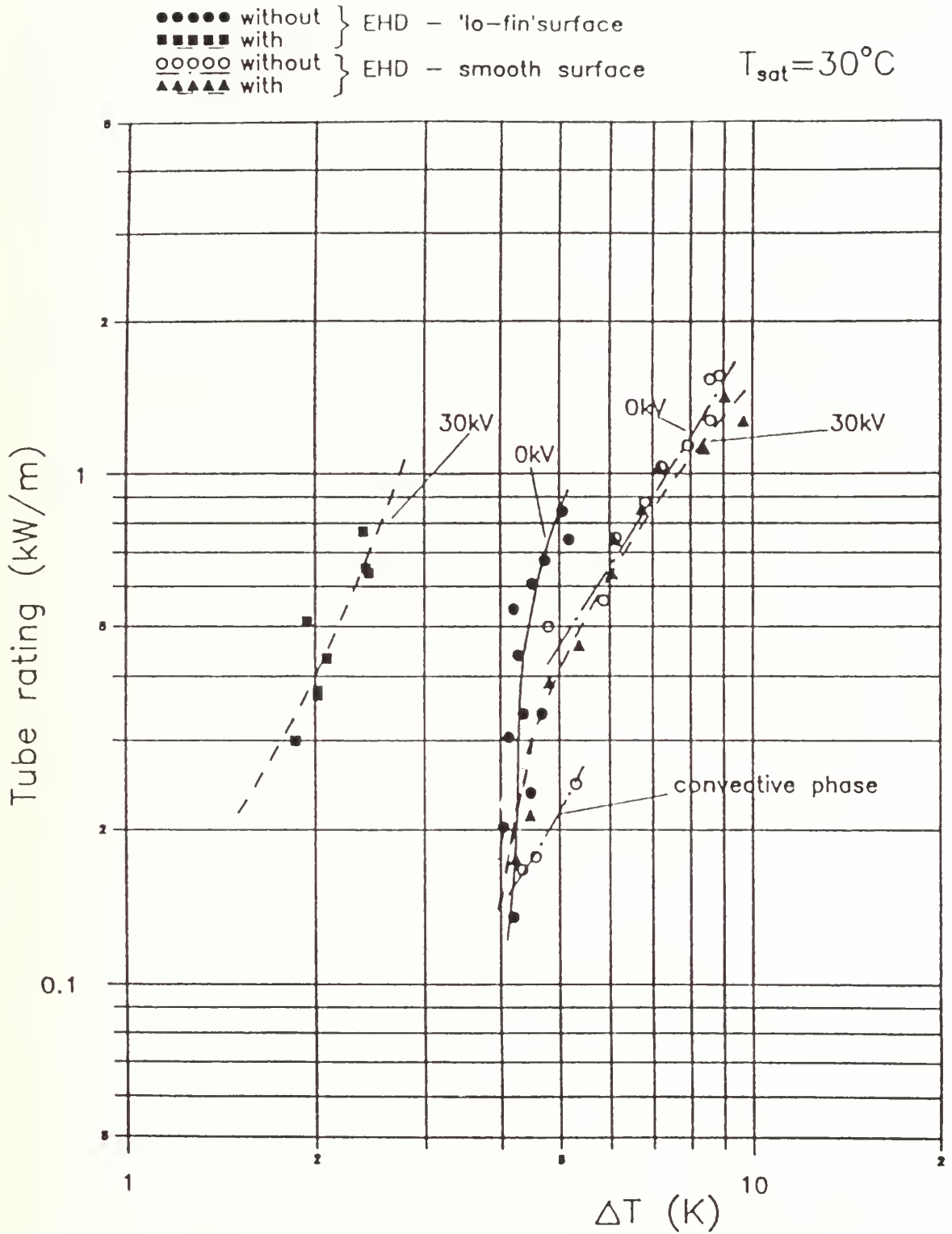

Figure 8: Comparison of EHD Enhancements for Boiling Heat Transfer from a Smooth and Low Integral-Fin Tube (3 x 3) Bundle in a Pool of CFC-114 (from Damianidis et al (1992))

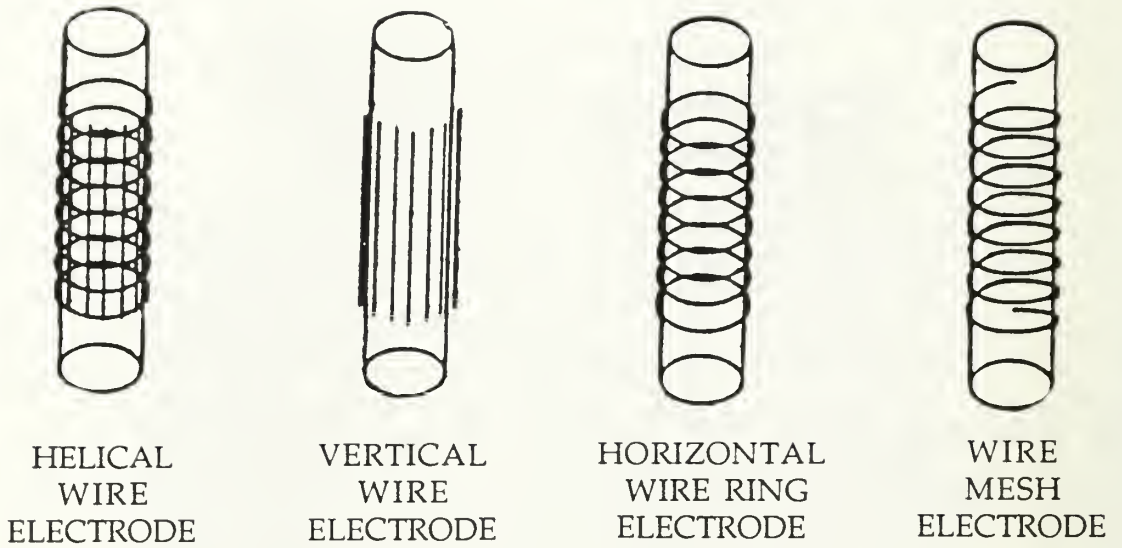

Figure 9: Electrode Design Configurations (from Yabe et al (1987))

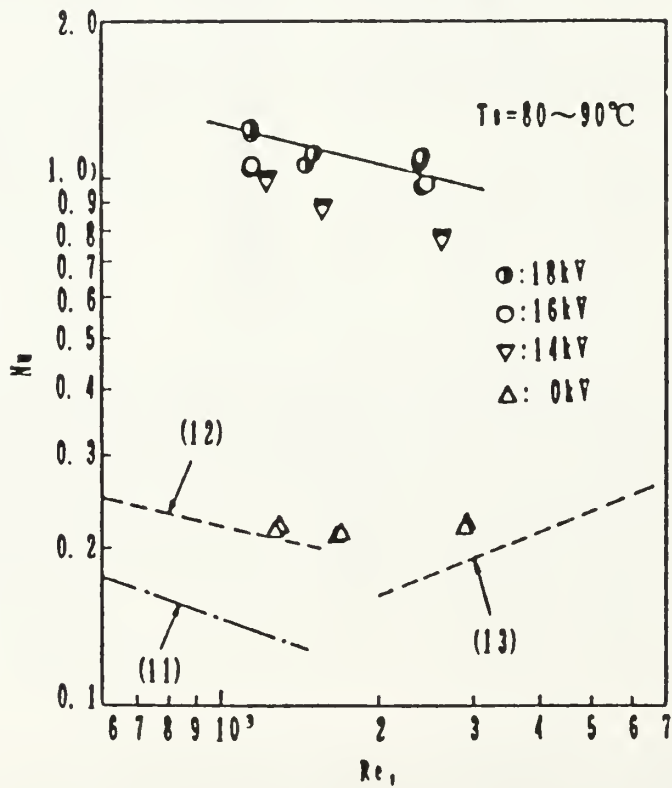

Figure 10: EHD Enhancement for Condensation Heat Transfer from a Vertical Smooth Tube Bundle (102 Tubes) in a Pool of CFC-114 (from Yamashita et al (1991))

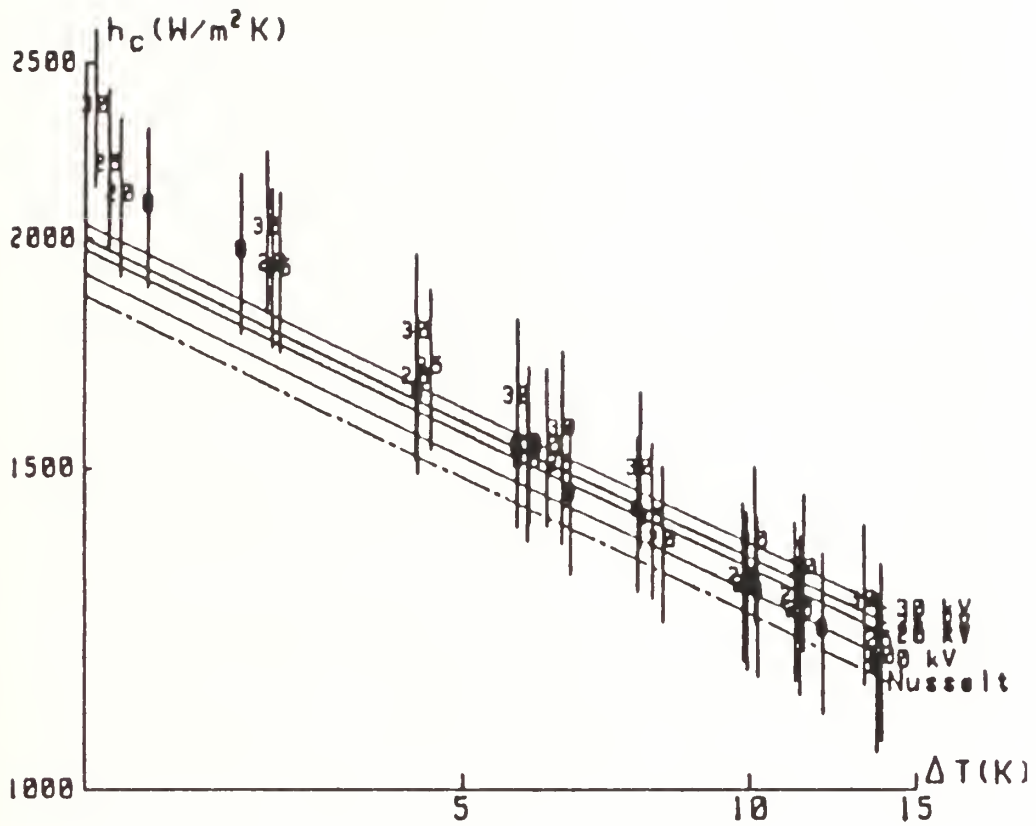

Figure 11: EHD Enhancement for Condensation Heat Transfer from a Horizontal Single Smooth Tube in a Pool of CFC-114 (from Trommelmans and Berghmans (1986))

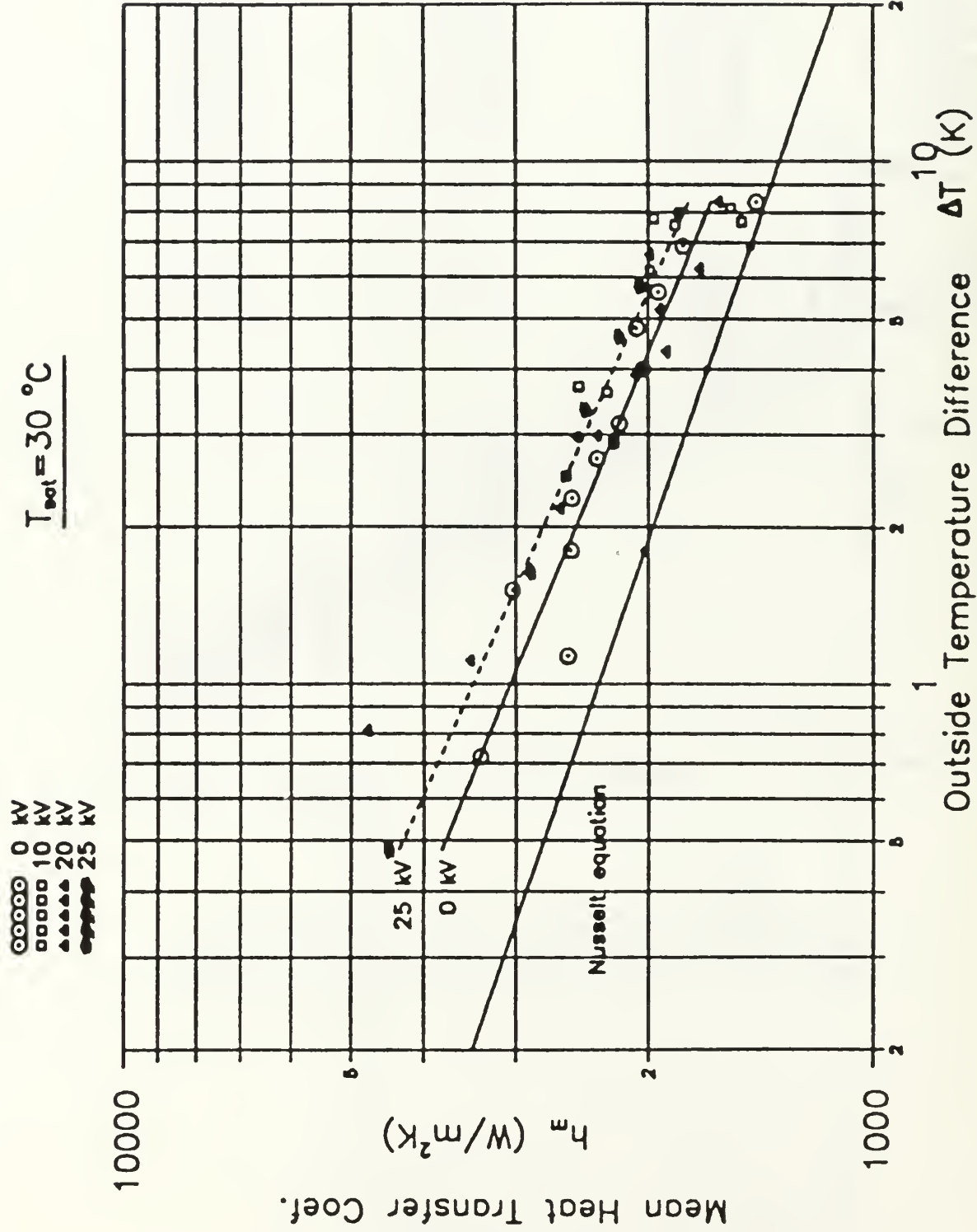

Figure 12: EHD Enhancement for Condensation Heat Transfer from a Horizontal Smooth Tube (3 x 3) Bundle in a Pool of CFC-114 (from Damianidis et al (1991))

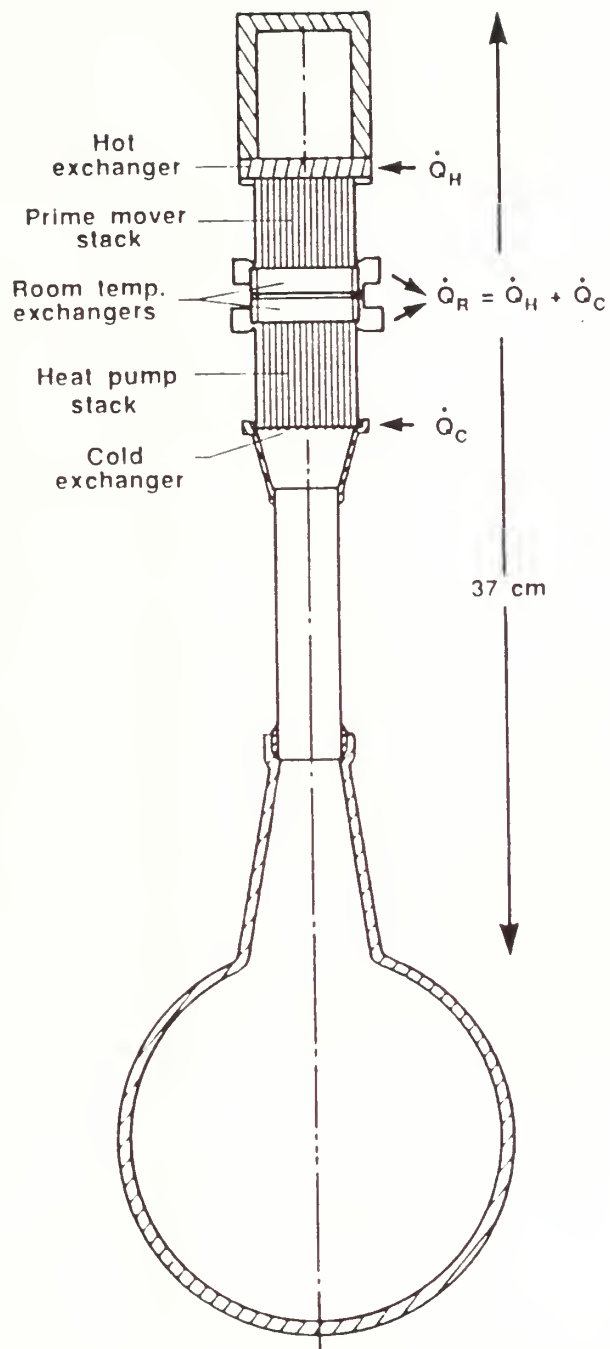
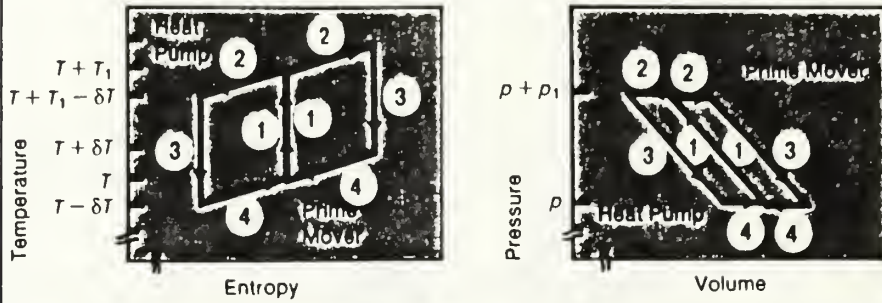

Figure 13: Schematic of a Heat Driven Refrigerator ('Beer Cooler') (from Swift (1988))

ACOUSTIC HEAT ENGINE CYCLE



Heat Pump
Small ∇T

Prime Mover
Large ∇T

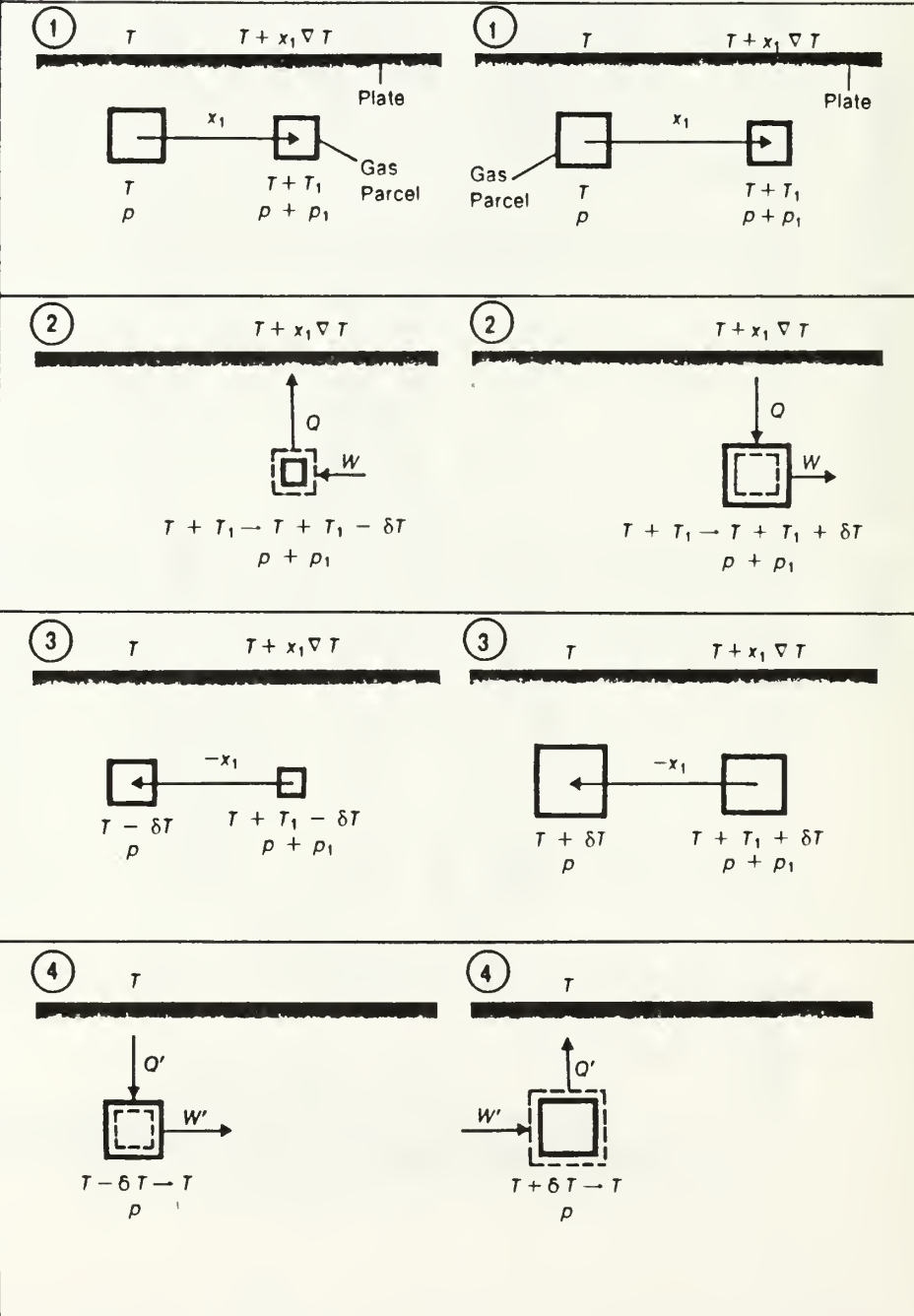

Figure 14: Schematic of the Acoustic Heat Engine Cycle (from Wheatley et al (1986))

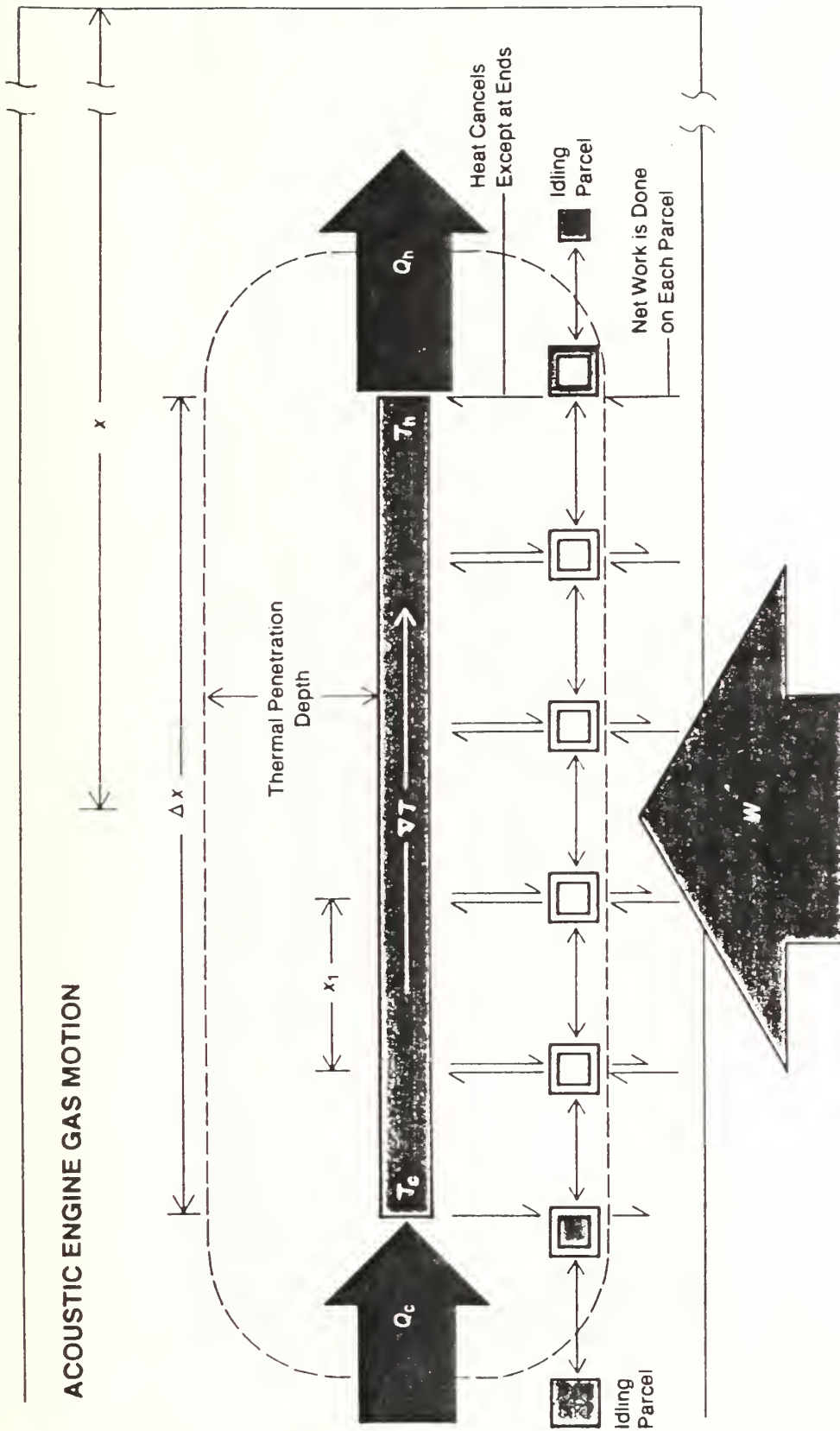

Figure 15: Schematic of the Acoustic Engine Gas Motion (from Wheatley et al (1986))

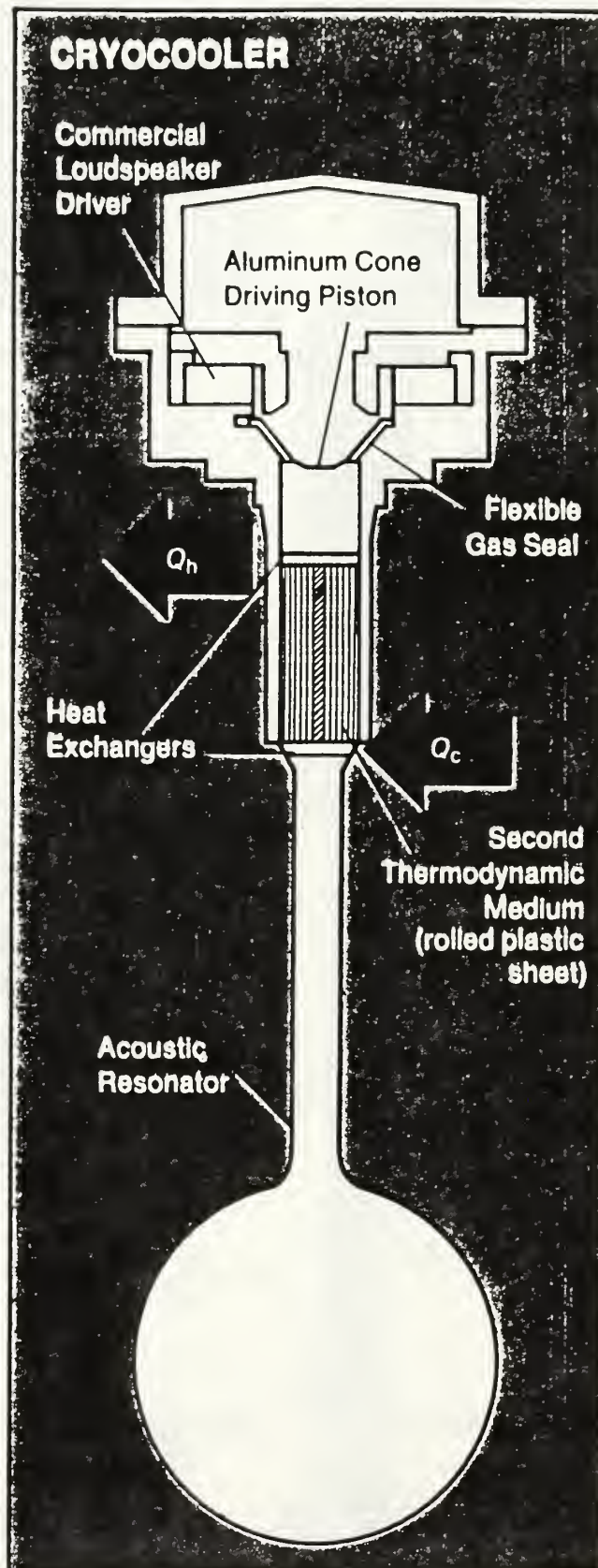

Figure 16: Schematic of the Thermoacoustic Refrigerator or Cryocooler (from Wheatley et al (1986))

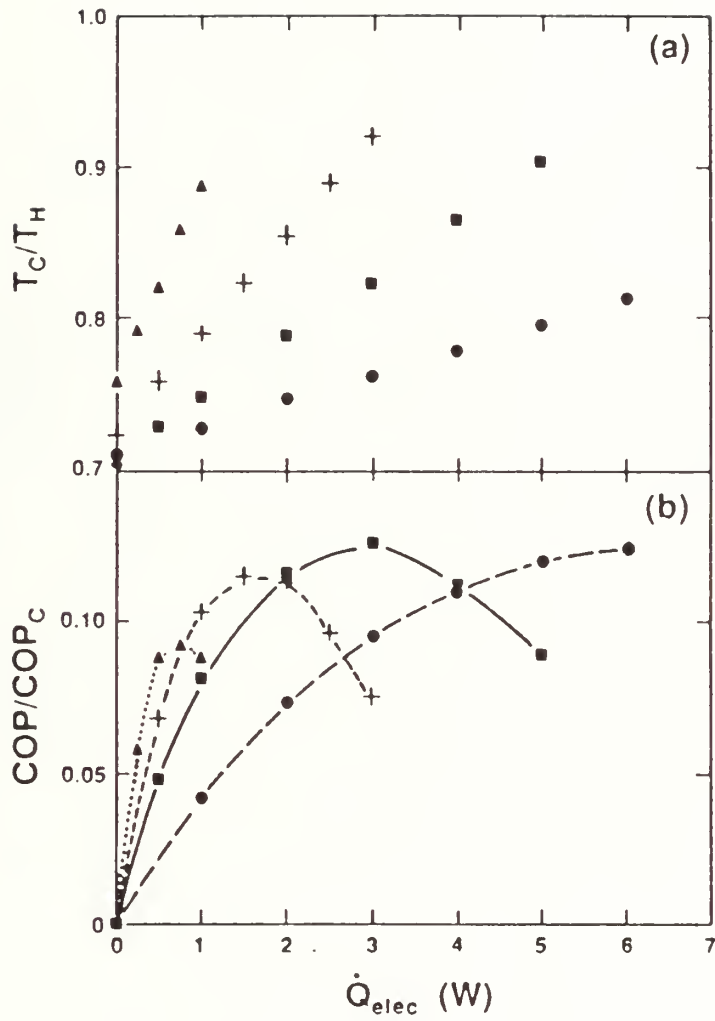

Figure 17: Measured Performance of the Thermoacoustic Refrigerator (from Swift (1988))

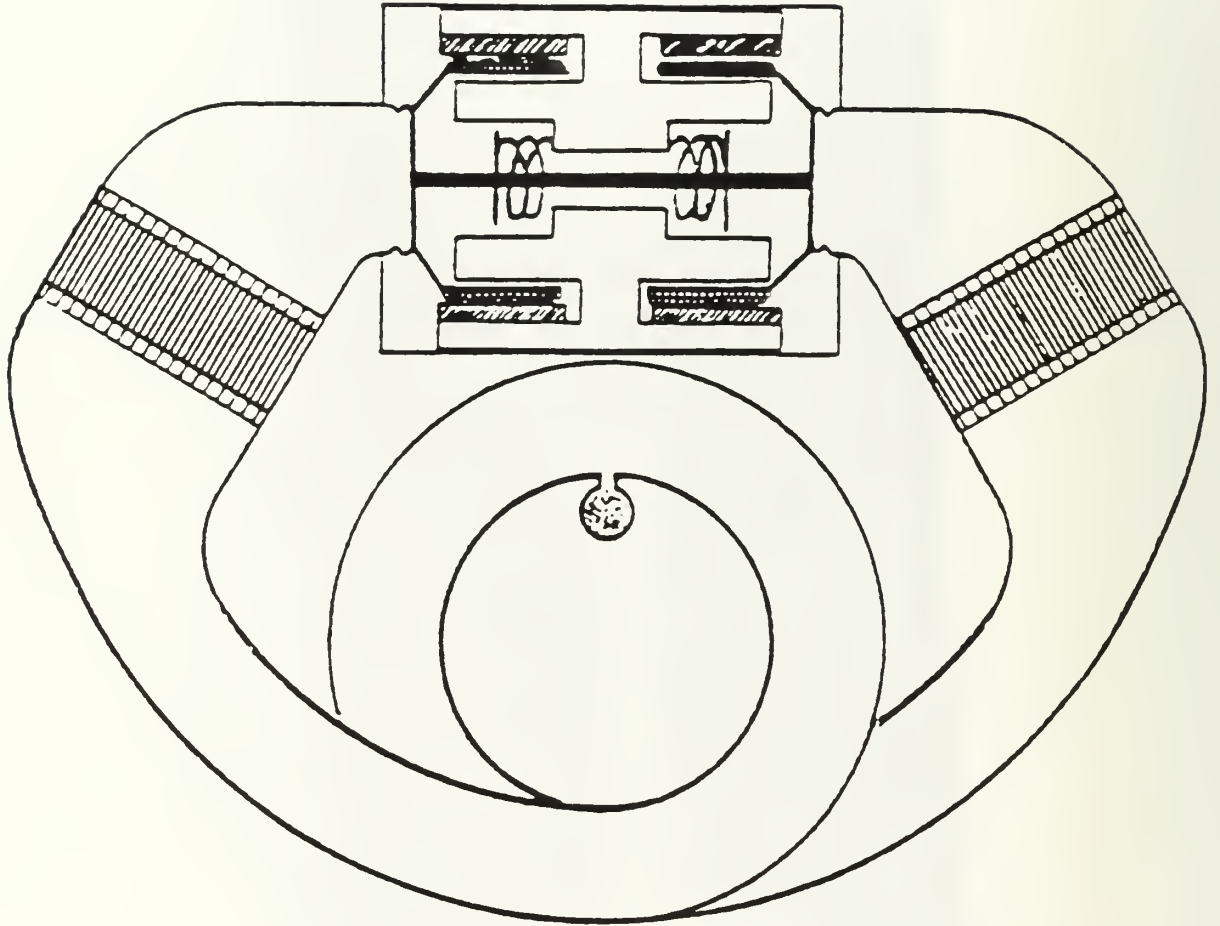

Figure 18: Schematic of a Half-Ton (2 kW) Capacity Thermoacoustic Chiller (from Garrett and Hofler (1991))

DISTRIBUTION LIST

	No. Copies
1. Defense Technical Information Center Cameron Station Alexandria, Virginia, 22304-6145	2
2. Library, Code 52 Naval Postgraduate School Monterey, California 93943-5000	2
3. Professor P. J. Marto, Code ME/Mx Department of Mechanical Engineering Naval Postgraduate School Monterey, California 93943-5000	2
4. Professor S. B. Memory, Code ME/Mr Department of Mechanical Engineering Naval Postgraduate School Monterey, California 93943-5000	3
5. Department Chairman, Code ME Department of Mechanical Engineering Naval Postgraduate School Monterey, California 93943-5000	1
6. Mr R. Helmick David Taylor Research Center Annapolis, Maryland 21402-5067	3
7. Mr B. G. Unkel NAVSEA (Code 56Y15) Department of the Navy Washington, D. C. 20362-5101	1



DUDLEY KNOX LIBRARY

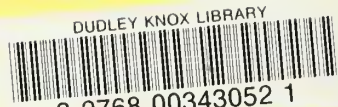

3 2768 00343052 1

0255014