

**AD-A251 595**



2

PL-TR-91-2290 (II)

**SENTRAN7: The Sensitivity Analysis Package  
for LOWTRAN7 and MODTRAN**

D. R. Longtin  
N. L. DePiero  
F. P. Pagliughi  
J. R. Hummel

SPARTA, Inc.  
24 Hartwell Avenue  
Lexington, MA 02173

27 November 1991

**DTIC  
ELECTE  
MAY 20 1992  
S B D**

Final Report (Volume II)  
September 1990 - July 1991

Approved for Public Release; Distribution Unlimited



**PHILLIPS LABORATORY  
AIR FORCE SYSTEMS COMMAND  
HANSCOM AIR FORCE BASE, MASSACHUSETTS 01731-5000**

**92-13349**



92 5 19 019

"This technical report has been reviewed and is approved for publication"

  
ROBERT R. BELAND  
CONTRACT MANAGER

  
DONALD E. BEDO  
BRANCH CHIEF

  
ALAN D. BLACKBURN, Col., USAF  
DIVISION DIRECTOR

This report has been reviewed by the ESD Public Affairs Office (PA) and is releasable to the National Technical Information Service (NTIS).

Qualified requestors may obtain additional copies from the Defense Technical Information Center. All others should apply to the National Technical Information Service.

If your address has changed, or if you wish to be removed from the mailing list, or if the addressee is no longer employed by your organization, please notify PL/IMA, Hanscom AFB, MA 01731-5000. This will assist us in maintaining a current mailing list.

Do not return copies of this report unless contractual obligations or notices on a specific document requires that it be returned.

# REPORT DOCUMENTATION PAGE

*Form Approved*  
OMB No. 0704-0188

Public reporting burden for this collection of information is estimated to average 1 hour per response, including the time for reviewing instructions, searching existing data sources, gathering and maintaining the data needed, and completing and reviewing the collection of information. Send comments regarding this burden estimate or any other aspect of this collection of information, including suggestions for reducing this burden, to Washington Headquarters Services, Directorate for Information Operations and Reports, 1215 Jefferson Davis Highway, Suite 1204, Arlington, VA 22202-4302, and to the Office of Management and Budget, Paperwork Reduction Project (0704-0188), Washington, DC 20503.

|  |   |  |  |
|--|---|--|--|
| 1. AGENCY USE ONLY (Leave blank)   | 2. REPORT DATE<br>27 NOV 1991                           | 3. REPORT TYPE AND DATES COVERED<br>FINAL REPORT, VOL II, SEP 1990 - JUL 1991  |  |
| 4. TITLE AND SUBTITLE<br>SENTRAN7: THE SENSITIVITY PACKAGE FOR LOWTRAN7 AND MODTRAN  |   | 5. FUNDING NUMBERS<br>PE 62101F<br>PR 7670 TA 15 WUAP<br>Contract- F19629-88-C-0038  |  |
| 6. AUTHOR(S)<br>D. R. LONGTIN, N. L. DEPIERO, F. M. PAGLIUGHI, AND J. R. HUMMEL  |   | 8. PERFORMING ORGANIZATION REPORT NUMBER<br><br>LTR91-013  |  |
| 7. PERFORMING ORGANIZATION NAME(S) AND ADDRESS(ES)<br>SPARTA, Inc.<br>24 Hartwell Avenue<br>Lexington, MA 02173  |   | 9. SPONSORING / MONITORING AGENCY NAME(S) AND ADDRESS(ES)<br>PHILLIPS LABORATORY<br>HANSCOM AFB, MA 01731-5000<br>CONTRACT MANAGER: ROBERT BELAND/GPOA |  |
| 9. SPONSORING / MONITORING AGENCY NAME(S) AND ADDRESS(ES)  |   | 10. SPONSORING / MONITORING AGENCY REPORT NUMBER<br><br>PL-TR-91-2290 (II)   |  |
| 11. SUPPLEMENTARY NOTES  |   |  |  |
| 12a. DISTRIBUTION / AVAILABILITY STATEMENT<br><br>APPROVED FOR PUBLIC RELEASE; DISTRIBUTION UNLIMITED  |   | 12b. DISTRIBUTION CODE   |  |
| 13. ABSTRACT (Maximum 200 words)<br><br>The computer code SENTRAN, originally developed by researchers at the Pennsylvania State University, permits users to rapidly evaluate transmittances and radiances from LOWTRAN in response to perturbations of input atmospheric conditions. The code provides a friendly and efficient interface to create multiple LOWTRAN input decks as well as graphical representation of the output in both 2D and 3D formats.<br>The main thrust of this effort was to upgrade the original SENTRAN code for use with LOWTRAN7. The new sensitivity analysis package has been named SENTRAN7. SENTRAN7 contains all of the features of the original SENTRAN code including: (1) interactive entry of LOWTRAN7 input parameters and directives for their perturbation, (2) intelligent generation of LOWTRAN7 input deck images, (3) autonomous post-processing of LOWTRAN7 outputs for data extraction, analysis, and graphical display, and (4) a help utility. Additionally, a number of new features are available in SENTRAN7 such as (1) compatibility with the moderate resolution code MODTRAN, (2) an on-line run feature, (3) screen display of available methodology and other input files, (4) safeguards to prevent existing files from being overwritten, (5) increased portability across hardware platforms, (6) on-line help within the Edit module, (7) tick marks on plots, and (8) a plot option for trace gas profiles.<br>In a parallel effort, a beta version of a sensitivity package for FACODE3 was developed and named SENCODE. Although this package is not available for public release, initial testing suggests that such a package is possible. |   |  |  |
| 14. SUBJECT TERMS<br><br>LOWTRAN7, MODTRAN, SENSITIVITY STUDIES, USER'S GUIDE  |   | 15. NUMBER OF PAGES<br>124   |  |
| 17. SECURITY CLASSIFICATION OF REPORT<br>UNCLASSIFIED  |   | 16. PRICE CODE   |  |
| 18. SECURITY CLASSIFICATION OF THIS PAGE<br>UNCLASSIFIED   | 19. SECURITY CLASSIFICATION OF ABSTRACT<br>UNCLASSIFIED | 20. LIMITATION OF ABSTRACT<br>SAR  |  |

## Contents

|       |   |    |
|-------|---|----|
| 1     | INTRODUCTION  | 1  |
| 1.1   | Background and Purpose of Study                             | 1  |
| 1.2   | Organization of the Report                                  | 2  |
| 2     | WORK PERFORMED ON SENTRAN7                                  | 4  |
| 2.1   | Notations Used in This Report                               | 4  |
| 2.2   | Brief Overview of SENTRAN7                                  | 4  |
| 2.3   | Upgrade of the Original SENTRAN Code                        | 5  |
| 2.4   | Improvements to the Original SENTRAN Code                   | 5  |
| 2.4.1 | Smarter Editing Restrictions                                | 7  |
| 2.4.2 | Improved Error Checking on User Inputs                      | 7  |
| 2.4.3 | Refined Identification of Major Molecular Absorbers         | 8  |
| 2.4.4 | Additional Plotting Capabilities                            | 8  |
| 2.5   | New Features in SENTRAN7                                    | 12 |
| 2.5.1 | Compatibility with MODTRAN                                  | 12 |
| 2.5.2 | Addition Of An On-Line Run Module                           | 13 |
| 2.5.3 | Displaying Available Methodology and Other Input Files      | 13 |
| 2.5.4 | Safeguards to Prevent Existing Files From Being Overwritten | 14 |
| 2.5.5 | Increased Portability Across Hardware Platforms             | 15 |
| 2.5.6 | On-line Help Within the Edit Module                         | 15 |
| 2.5.7 | Tick Marks and Labeling of Plots                            | 16 |
| 2.5.8 | Plot Option for Trace Gas Profiles                          | 16 |
| 3     | INSTALLING AND RUNNING SENTRAN7                             | 18 |
| 3.1   | Overview of Software  | 18 |
| 3.2   | Installing the Program                                      | 18 |

|         |  |    |
|---------|--|----|
| 3.3     | LOWTRAN7 and MODTRAN Requirements                    | 20 |
| 3.4     | Using the <i>DIRECTORY</i> File                      | 20 |
| 4       | USERS GUIDE FOR SENTRAN 7                            | 21 |
| 4.1     | Overview of SENTRAN7                                 | 21 |
| 4.1.1   | Code Philosophy                                      | 21 |
| 4.1.2   | Design Criteria                                      | 21 |
| 4.2     | Program Structure                                    | 23 |
| 4.2.1   | Help Module  | 23 |
| 4.2.2   | Load/Save Module                                     | 23 |
| 4.2.3   | Edit Module  | 26 |
| 4.2.3.1 | Using the Edit Module                                | 26 |
| 4.2.3.2 | Movement Through the Edit Module                     | 26 |
| 4.2.3.3 | Data Entry in the Edit Module                        | 29 |
| 4.2.3.4 | Perturbing Data in the Edit Module                   | 30 |
| 4.2.3.5 | On-line Help Utility Within the Edit Module          | 32 |
| 4.2.3.6 | Notes About the Edit Module                          | 33 |
| 4.2.4   | Compile Module                                       | 34 |
| 4.2.4.1 | Invoking the Compile Module                          | 34 |
| 4.2.4.2 | MESH and NOMESH Compiler Options                     | 35 |
| 4.2.4.3 | Error File Option                                    | 36 |
| 4.2.5   | Select Module  | 37 |
| 4.2.6   | Run Module   | 37 |
| 4.2.7   | Graph and Analyze Module                             | 38 |
| 4.2.7.1 | Types of Plots Available                             | 39 |
| 4.2.7.2 | Invoking the Graph and Analyze Module                | 39 |
| 4.2.7.3 | Specifying the Plotting Parameters                   | 41 |
| 4.2.7.4 | Restrictions Imposed by the Graph and Analyze Module | 41 |
| 4.2.7.5 | Commands Available With the Graph and Analyze Module | 41 |
| 4.2.8   | Plotting Trace Gas Input Profiles                    | 47 |
| 4.2.9   | Miscellaneous  | 49 |
| 5       | SENTRAN7 TUTORIAL                                    | 54 |
| 5.1     | Basic Concepts of the User Interface                 | 54 |
| 5.2     | Conventions Used in the Tutorials                    | 54 |
| 5.3     | SENTRAN7 Tutorial #1                                 | 55 |
| 5.3.1   | Getting Started                                      | 55 |
| 5.3.2   | Using the Load and Save Module                       | 55 |
| 5.3.3   | Using the Edit Module                                | 59 |
| 5.3.4   | Using the Run Module                                 | 67 |
| 5.3.5   | Using the Graph and Analyze Module For Tutorial #1   | 69 |
| 5.4     | SENTRAN7 Tutorial #2                                 | 80 |
| 5.4.1   | Using the Edit Module                                | 80 |
| 5.4.2   | Using the Compile and Run Modules                    | 83 |

|  |     |
|--|-----|
| 5.4.3 Using the Graph and Analyze Module for Tutorial #2 | 83  |
| 6 PROTOTYPE SENSITIVITY PACKAGE FOR FASCODE3, SENCODE    | 87  |
| 6.1 Framework of SENCODE                                 | 87  |
| 6.2 Input Restrictions                                   | 87  |
| 6.3 Additional Comments                                  | 88  |
| 7 SUMMARY AND RECOMMENDATIONS FOR FUTURE STUDIES         | 91  |
| 7.1 Summary  | 91  |
| 7.2 Recommendations for Future Studies                   | 91  |
| 7.2.1 Future Work on SENTRAN7                            | 91  |
| 7.2.2 Future Work on SENCODE                             | 92  |
| REFERENCES   | 94  |
| APPENDIX A: File Structure                               | 95  |
| APPENDIX B: Code Changes to LOWTRAN7 and MODTRAN         | 100 |
| APPENDIX C: Quick Reference Guide for SENTRAN7           | 104 |
| APPENDIX D: Flow Chart for the Graph and Analyze Module  | 112 |

|                           |                                     |
|---------------------------|-------------------------------------|
| <b>Accession For</b>      |                                     |
| NTIS GRA&I                | <input checked="" type="checkbox"/> |
| DTIC TAB                  | <input type="checkbox"/>            |
| Unannounced               | <input type="checkbox"/>            |
| Justification             |                                     |
| By _____                  |                                     |
| Distribution/             |                                     |
| <b>Availability Codes</b> |                                     |
| Dist                      | Avail and/or<br>Special             |
| A-1                       |                                     |



## Figures

|    |  |    |
|----|--|----|
| 1  | Contents of the File <i>MAJABS.DAT</i> Which Is Used To Display Regions of Active Molecular Absorption                       | 10 |
| 2  | Representative Display of the Major Molecular Absorbers Used in a Given SENTRAN7 Calculation                                 | 11 |
| 3  | A Sample SENTRAN7 Screen Displaying the Available Methodology Files  | 14 |
| 4  | A Sample SENTRAN7 Screen Message to Warn Users Against Writing Over Files  | 15 |
| 5  | Example of a 3-D Plot Created by the Graph and Analyze Module of SENTRAN7  | 17 |
| 6  | SENTRAN7 Main Menu   | 24 |
| 7  | The Introductory Help Screen in the Help Module  | 25 |
| 8  | An Example of a Screen from SENTRAN7 Editing Module  | 27 |
| 9  | Prompt to Check the Variables on a Given LOWTRAN7 Input Card   | 29 |
| 10 | On-line Help Screen Within Editing Module of SENTRAN7  | 33 |
| 11 | SENTRAN7 Screen Displaying the Choices of Model Programs to Execute  | 38 |
| 12 | Example of an Initial Screen in the Graph and Analyze Module   | 39 |
| 13 | An Example of a Command Screen from the SENTRAN7 Graph and Analyze Module  | 42 |
| 14 | An Example of a 3-D Plot from the SENTRAN7 Graph and Analyze Module  | 43 |
| 15 | An Example of an On-Line Help Screen Within Graph and Analyze Module of SENTRAN7   | 47 |
| 16 | An Example of the Command Used to Perturb the O <sub>3</sub> Input Profile on the LOWTRAN7 Input Card 2C by 20%              | 49 |
| 17 | Example of the Command to Move the Cursor Up One Line to the O <sub>3</sub> Parameter on the LOWTRAN7 Input Card 2C Sequence | 50 |

|    |   |    |
|----|---|----|
| 18 | Example of the Command to Write the O <sub>3</sub> Input Profile Specified by the LOWTRAN7 Input Card 2C to a Data File | 50 |
| 19 | Example of the Screen Displayed After the Perturbed O <sub>3</sub> Input Profile Has Been Written to a File             | 51 |
| 20 | Sample of a Trace Gas Input Profile Data File ( <i>O3.3D</i> ) as Created Using a 20% Perturbation                      | 52 |
| 21 | An Example of a 2-D Plot of an O <sub>3</sub> Input Profile with ± 20% Perturbations Assumed                            | 53 |
| 22 | SENTRAN7 Screen Displayed When the <i>LAST.MTH</i> Methodology File is not Found to Exist                               | 56 |
| 23 | The Main Menu of SENTRAN7   | 56 |
| 24 | Screen Prompt for Specifying Use of the Load or Save Options  | 57 |
| 25 | Example of the SENTRAN7 Screen Listing the Available Methodology Files to Load Into SENTRAN7                            | 57 |
| 26 | Example of the Screen Displayed to Edit Card 1  | 60 |
| 27 | Example of How to Implement the On-Line Help Utility Within the SENTRAN7 Edit Module                                    | 60 |
| 28 | Example of the On-Line Help Information in the SENTRAN7 Edit Module   | 62 |
| 29 | Example of the Final Screen Displayed After Editing the LOWTRAN7 Input Card 1   | 62 |
| 30 | Example of the Initial Screen Displayed to Edit the LOWTRAN7 Card 2   | 63 |
| 31 | Example of the Initial Screen Displayed to Edit the LOWTRAN7 Input Card 3   | 63 |
| 32 | Example of the Final Screen Displayed After Editing Card 3  | 64 |
| 33 | Example of the Initial Screen Displayed to Edit Card 4  | 64 |
| 34 | Final Screen Displayed After Editing Card 4   | 66 |
| 35 | Example of the Screen Displaying the Compile Option After All Cards Have Been Set                                       | 66 |
| 36 | SENTRAN7 Prompt for the Input File Name and Compiler Options  | 66 |
| 37 | Example of the On-Line Feedback Provided While SENTRAN7 Compiles the User Specified Input Cards                         | 67 |
| 38 | Example of the Screen Displaying the Programs Available   | 68 |
| 39 | Example of the Prompt Requesting the Name of the Input File   | 68 |
| 40 | Example of the Screen Displaying the Completion of a LOWTRAN7 Calculation   | 69 |
| 41 | Initial Screen Display for SENTRAN7's Graph and Analyze Module  | 70 |
| 42 | Example of the Screen Prompt Displayed Asking for the X Axis Parameter  | 71 |
| 43 | Example of the Screen Prompt Displayed for the y Axis Parameter   | 72 |
| 44 | Example of the G&A Screen Prompting for the Wavenumber  | 72 |
| 45 | Example of the G&A Screen Prompting for the Units to Use in Plotting  | 73 |
| 46 | Example of the G&A Screen Prompting for the Selection of the Z Axis Parameter   | 74 |
| 47 | Example of the G&A Screen Prompting for the Name of the Data File to Plot   | 74 |

|    |   |    |
|----|---|----|
| 48 | Example of the Screen Displaying the "Help" Options Available for Graph and Analyze Commands  | 76 |
| 49 | Example of the G&A Screen Showing a Request for "Help" on the PLOT Command  | 76 |
| 50 | Example of the Screen Showing "Help" Information About the PLOT Command   | 77 |
| 51 | Example of the G&A Screen Prompting for Rotation Angles to be Used While Plotting   | 77 |
| 52 | Example of Plot 1, a 3-D Plot of Total Transmittance as a Function of H1 and RANGE for a 45° Rotation of Both Axes  | 78 |
| 53 | Example of the G&A Screen Displayed When the Requested Graph Has Been Plotted to a File   | 79 |
| 54 | Example of Plot 2, a 3-D Plot of Derivative of Total Transmittance With Respect to RANGE as a Function of RANGE and H1 for a 45° Rotation of Both Axes                              | 79 |
| 55 | Example of Plot 3, a 3-D Plot of Optical Depth as a Function of RANGE and H1 for a 45° Rotation of Both Axes  | 80 |
| 56 | Summary of Input Parameters for Tutorial #2   | 81 |
| 57 | Example of Plot 1, a 3-D Plot of Total Transmittance as a Function of Wavenumber and Model Atmosphere Number for Viewing Angles of -11.25° and 11.25°                               | 85 |
| 58 | Example of Plot 2, a 3-D Plot of Differential Transmittance as a Function of Layer Number and Wavenumber, for a Midlatitude Winter Atmosphere and Viewing Angles of -45° and 11.25° | 85 |
| 59 | Example of the Initial Screen for SENTRAN7 Graph and Analyze Features for Tutorial #2   | 86 |

## Tables

|    |  |    |
|----|--|----|
| 1  | LOWTRAN7 Input Parameters That Cannot Be Perturbed in SENTRAN7   | 6  |
| 2  | LOWTRAN7 Card Series That are Read as External Data Files  | 6  |
| 3  | List of Molecules For Which Regions of Absorption Are Displayed by the SENTRAN7 Compiler                               | 9  |
| 4  | Plots Available From SENTRAN7's Graph and Analyze Module   | 12 |
| 5  | Files Included with the SENTRAN7 Package   | 19 |
| 6  | List of SENTRAN7 Modules   | 24 |
| 7  | List of Cursor Control Commands in the Edit Module of SENTRAN7   | 27 |
| 8  | List of SENTRAN7 Perturbation Directive Syntaxes in the Edit Module  | 30 |
| 9  | Examples of Perturbation Directives  | 31 |
| 10 | Allowable Compiler Commands As Typed From the Main Menu  | 34 |
| 11 | Examples of Compiler Commands as Typed From the Main Menu  | 35 |
| 12 | An Example of Combinations of LOWTRAN7 Runs for the MESH and NOMESH Compiler Options When Two Parameters Are Perturbed | 36 |
| 13 | Type of Plots Available in the SENTRAN7 Graph and Analyze Module   | 40 |
| 14 | List of Numerical Commands in the SENTRAN7 Graph and Analyze Module  | 44 |
| 15 | List of Plotting Commands in the SENTRAN7 Graph and Analyze Module   | 45 |
| 16 | List of I/O and Control Commands in the SENTRAN7 Graph and Analyze Module  | 45 |
| 17 | Perturbation Options in the Beta Version of SENCODE  | 89 |
| 18 | External Data Files Used By the Beta Version of SENCODE to Represent Long FASCODE Card Series                          | 90 |

## **Acknowledgements**

We wish to thank Ms. Gail Anderson, Mr. Francis Kneizys, Mr. Leonard Abreu and Mr. James Chetwynd of the Optical Environment Division of the Geophysics Directorate of the Phillips Laboratory for their suggestions and support in developing SENTRAN7. We also wish to thank Drs. Charles Randall and Ian Robertson of The Aerospace Corporation and Dr. Charles Lo Presti of The Battelle Pacific Northwest Laboratory for their efforts in testing of preliminary versions of SENTRAN7. Drs. Ken Tomiyama and Michael Hogan of the Pennsylvania State University also deserve recognition as the developers of the original SENTRAN code. Finally, we wish to thank Capt. Leslie Belsma of the US Air Force Space Division, the sponsor of the study.

## **SENTRAN7: The Sensitivity Analysis Package for LOWTRAN7 and MODTRAN**

### **1 INTRODUCTION**

#### **1.1 Background and Purpose of Study**

The Optical Environment Division of the Geophysics Directorate of the Phillips Laboratory (PL/GPO) has developed a number of computer codes to evaluate atmospheric transmittance and background radiance for a given atmospheric path and frequency region. The LOWTRAN7<sup>1</sup> model, and its predecessor LOWTRAN6<sup>2</sup>, have been recognized by the DoD community as the standard for calculating atmospheric transmission and radiance at low spectral resolution. The LOWTRAN series has been widely used for studies of atmospheric propagation of electromagnetic waves in the visible and infrared.

An important key to a successful utilization of LOWTRAN is the accuracy of the input atmospheric data. In order for the LOWTRAN output to be useful, the

---

<sup>1</sup> Kneizys, F.X., Shettle, E.P., Abreu, L.W., Chetwynd, J.H., Anderson, G.P., Gallery, W.O., Selby, J.E.A., and Clough, S.A. (1988) *Users Guide to LOWTRAN7*, Air Force Geophysics Laboratory, Hanscom AFB, MA, AFGL-TR-88-0177, ADA206773.

<sup>2</sup> Kneizys, F.X., Shettle, E.P., Gallery, W.O., Chetwynd, J.H., Abreu, L.W., Selby, J.E.A., Clough, S.A., and Fenn, R.W. (1983) *Atmospheric Transmittance/Radiance: Computer Code LOWTRAN 6*, Air Force Geophysics Laboratory, Hanscom AFB, MA, AFGL-TR-83-0187, ADA137796.

corresponding input must be accurate. However, some atmospheric variables are inherently difficult to obtain or to predict accurately due to their natural variation. Unavoidable uncertainties occur in these variables regardless of how they are obtained. The effects of these uncertainties on LOWTRAN computations must be critically evaluated if the LOWTRAN results are to be meaningful and reliable.

In response to these needs, a systematic sensitivity analysis plan was developed for LOWTRAN6. The plan was to quantitatively, as well as qualitatively, evaluate variations in transmittances and radiances from LOWTRAN6 against perturbations in input atmospheric conditions. The plan eventually evolved into a computer software package, called SENTRAN<sup>3</sup> (SENSitivity analysis plan for lowTRAN). The capability of SENTRAN greatly exceeded the originally conceived specifications for the plan, in that its usefulness was not limited to sensitivity analyses. It became apparent that SENTRAN could revolutionize the way in which LOWTRAN6 was used and the scope of analyses that could be performed.

Since the development of the SENTRAN code, the Geophysics Directorate released LOWTRAN7 which contains revised formats for the input card images and additional parameters to characterize the atmospheric path. Therefore, the main purpose of this effort has been to make SENTRAN compatible with LOWTRAN7. The new computer code is called SENTRAN7. At the same time, the scope of SENTRAN7 was broadened to include sensitivity studies for MODTRAN.<sup>4</sup> The decision to include MODTRAN is reasonable because the format of the input card images for MODTRAN is essentially the same as LOWTRAN7. With the addition of MODTRAN, users can now perform sensitivity studies for spectral resolutions down to  $2 \text{ cm}^{-1}$ , instead of  $20 \text{ cm}^{-1}$  as with LOWTRAN7.

## 1.2 Organization of the Report

This report consists of seven chapters and four appendices. The report is complete in itself, although much of the material is taken from the original SENTRAN final report.<sup>3</sup> Chapter 2 describes the work performed in this effort, including the upgrade to LOWTRAN7 and new features which have been added. Chapter 3 describes the steps required to install and run SENTRAN7 on a user's computer system. Chapter 4 contains a Users Guide which gives a general overview of SENTRAN7, along with a detailed description of how to use SENTRAN7. Chapter 5 is a Tutorial which leads the user through a series of brief exercises with SENTRAN7. Chapter 6 describes initial efforts to develop an alternate sensitivity package for

<sup>3</sup> Tomiyama, K. and Hogan, M. (1988) *Sensitivity Evaluation Plan for LOWTRAN*, Department of Electrical Engineering, The Pennsylvania State University.

<sup>4</sup> Berk, A., Bernstein, L.S., and Robertson, D.C. (1989) *MODTRAN: A Moderate Resolution Model for LOWTRAN7*, Air Force Geophysics Laboratory, Hanscom AFB, MA, AFGL-TR-89-0122, ADA214337.

FASCOD3.<sup>5</sup> Conclusions and suggestions for further research are summarized in Chapter 7. Appendix A describes the input and output files used by SENTRAN7. Appendix B contains the source code changes made to LOWTRAN7 and MODTRAN. Appendix C is a Quick Reference Guide which contains brief summaries of SENTRAN7 commands and files that make up the SENTRAN7 package. Finally, Appendix D contains a flow chart of SENTRAN7's Graph and Analyze Module's program flow.

Familiarity with LOWTRAN7 and MODTRAN is presumed throughout this report. Therefore, the LOWTRAN7 Users Guide<sup>1</sup> and the MODTRAN Users Guide<sup>4</sup> should be used as companion guides for learning the SENTRAN7 system.

---

<sup>5</sup> Clough, S.A., Kneizys, F.X., Anderson, G.P., Shettle, E.P., Chetwynd, J.H., Abreu, L.W., Hall, L.A., and Worsham, R.D. (1989) *FASCOD3: Spectral Simulation in IRS'88: Current Problems in Atmospheric Radiation*, J. Lenoble and J.F. GeLeyn (Eds.), A. Deepak Publishing, Hampton, VA, pp. 372-375.

## 2 WORK PERFORMED ON SENTRAN7

This chapter describes specific tasks performed on SENTRAN7 during the current effort. The tasks are subdivided into three categories: coding changes required to upgrade the original SENTRAN code, improvements made to the original SENTRAN code, and new features included in SENTRAN7. The decision to include various new features in SENTRAN7 was based on feedback from prospective users, as well as time constraints.

### 2.1 Notations Used in This Report

Throughout this report, the following notations are used:

- Commands that must be entered by the user are set off by single quotation marks and appear in boldface in lower case print, (*e.g.*, **'help'**). (The '' delimiters are not entered as part of the command.) Note that SENTRAN7 is case insensitive and, therefore, users can enter all commands in lower or upper case.
- File names used by SENTRAN 7 appear in italics (*e.g.*, *TAPE7.OUT*). The file names are written in either upper or lower case, exactly as they would appear on a UNIX computer system, which is case sensitive. Note that if the user is operating SENTRAN7 on a UNIX computer system, all input and output files created by SENTRAN7 are in upper case. This is because SENTRAN7 internally converts all commands entered by the user to upper case and, therefore, accesses all file names within these commands as upper case file names. UNIX system users only need to be concerned with the file name case when accessing these files from outside of SENTRAN7. If running SENTRAN7 on a VAX/VMS computer system, all file names are in upper case.
- The word, RETURN, implies hitting the return (or enter) key on the user's keyboard.

### 2.2 Brief Overview of SENTRAN7

SENTRAN7 is structured into a number of subprograms called modules. Each module performs a specific task to aid users in their sensitivity studies. These modules include:

- A **Load/Save Module** for loading and saving SENTRAN7 methodology files
- An **Edit Module** for specifying the values of parameters on LOWTRAN7 card images, along with directions for their perturbation

- A **Compile Module** for creating LOWTRAN7 input files
- A **Select Module** for selecting which transmission model to execute
- A **Run Module** for executing the selected transmission model
- A **Graph and Analyze Module (G & A)** for extracting output data for data analysis and plotting
- A **Help Module** for providing on-line help for SENTRAN7 users

### 2.3 Upgrade of the Original SENTRAN Code

The Edit and Compile Modules in the original SENTRAN code were updated to mimic the flow through LOWTRAN7. As with the original code, some of LOWTRAN7's input parameters cannot be perturbed because their perturbation creates different flows through the input card images. Table 1 shows the input parameters in LOWTRAN7 that are restricted to one value (*i.e.*, no perturbation directives allowed) in SENTRAN7.

Data for some LOWTRAN7 input cards cannot be entered easily within SENTRAN7 because it involves excessive amounts of terminal input. For these card series, SENTRAN7 reads the input data from external files with default extensions. These files must be created off-line by the user. During an editing session, SENTRAN7 prompts users for the names of these files. For reference, Table 2 lists the LOWTRAN card series that are read as external files and their default extensions. Appendix A gives a detailed description of each of these files. The format of the external files should match the format of the LOWTRAN7 input cards that they represent.

After specifying an external data file, SENTRAN7 allows users to perturb input variables in the file by means of a percent perturbation. For the Card 2C series, the percent perturbation is only applied to the layers of the minor and trace gas profile where the units control variable, JCHAR, is not set to a model atmosphere between 1 and 6. For the Card 2D series, the percent perturbation is applied to all (47) wavelengths of aerosol attenuation data for a particular altitude region. It is noted that the Card 3B series for aerosol phase functions cannot be perturbed in the current version of SENTRAN7. (Note: the notation in this paragraph demonstrates the need to be familiar with LOWTRAN7 and MODTRAN.)

### 2.4 Improvements to the Original SENTRAN Code

The upgrade of the original SENTRAN code to LOWTRAN7 constituted a large portion of the current effort. During the upgrade however, a number of existing features in the original code were improved. These additional improvements are described below.

Table 1. LOWTRAN7 Input Parameters That Cannot Be Perturbed in SENTRAN7

| INPUT<br>PARAMETER | CARD | COMMENT                      |
|--------------------|------|------------------------------|
| MODEL              | 1    | Restricted when MODEL=0 or 7 |
| ITYPE              | 1    |                              |
| IEMSCT             | 1    |                              |
| IMULT              | 1    |                              |
| IM                 | 1    | Internally set by SENTRAN7   |
| NOPRT              | 1    |                              |
| IHAZE              | 2    | Restricted when IHAZE=7      |
| ICLD               | 2    |                              |
| IVSA               | 2    |                              |
| IPARM              | 3A1  |                              |
| IPH                | 3A1  |                              |
| ISOURC             | 3A1  |                              |
| V1, V2, DV         | 4    |                              |

Table 2. LOWTRAN7 Card Series That are Read as External Data Files

| CARD<br>SERIES          | FILE<br>EXTENSION | CONTENTS  |
|-------------------------|-------------------|---|
| 2C<br>2C1<br>2C2<br>2C3 | <i>.PRO</i>       | User defined minor and trace profiles. Repeat 2C1 through 2C3 to describe complete vertical profile |
| 2D<br>2D1<br>2D2        | <i>.AER</i>       | Aerosol or cloud scaling factors versus wavelength. Repeat 2D2 as necessary for 47 wavelengths      |
| 3B1<br>3B2              | <i>.PHS</i>       | Aerosol phase function. Repeat 3B2 as necessary to describe entire phase function                   |

### 2.4.1 Smarter Editing Restrictions

In a few instances, the original SENTRAN code allowed users to specify LOWTRAN6 input parameters that did not pertain to the particular problem being simulated. For example, users were always able to set the wind speed on Card 2, even though it was only used with the Navy maritime aerosol model (IHAZE=3). Early in the upgrade process, it became clear that this shortfall could lead to confusion among users of LOWTRAN7.

Given the complicated nature of the LOWTRAN7 input card images, SENTRAN7 contains "smarter" editing restrictions that allow users to specify only the required LOWTRAN7 input parameters. That is, some LOWTRAN7 input cards or individual variables are only required if other variables are specified. For example, LOWTRAN7's multiple scattering option can only be invoked if radiances are being calculated. The SENTRAN7 editor has been designed to take these kinds of restrictions into account, thereby trying to simplify the input process (and frequent referrals to the LOWTRAN7 technical manual) for the user. At the same time, the SENTRAN7 editor internally "hardwires" the values of some input parameters (or resets them to zero), based on previous user inputs. Users will encounter this enhanced feature of SENTRAN7 primarily while editing Cards 1, 2, 3, and 3A2.

### 2.4.2 Improved Error Checking on User Inputs

During an editing session, the original SENTRAN code performed error checking on a LOWTRAN6 parameter by comparing the user input with numerical limits internally set within the code. This is an extremely useful feature; however, some of the limits did not adequately represent the LOWTRAN6 parameters. Consequently, a subsequent LOWTRAN6 run could automatically reset some input parameters and produce confusion. Therefore, considerable attention was devoted to providing error checking on user inputs. Improved limits on LOWTRAN7 inputs are based on those from the Users Guide for LOWTRAN7<sup>1</sup>, common sense, and personal experience.

The user is urged to note, however, that the current version of SENTRAN7 **does not** check input data from external files for physical consistency. Although this feature would be extremely valuable for user-defined atmospheres on Card 2C, a complete and thorough treatment of the problem was beyond the current effort. Therefore, users must recognize that certain perturbations of pressure, temperature, and/or water vapor can lead to physical inconsistencies, such as relative humidities exceeding 100%. (Note: Both LOWTRAN & MODTRAN reset relative humidities greater than 100% to 100% during calculations.) Also, physical inconsistencies are possible in the Card 2D series when users perturb aerosol extinction, absorption, and asymmetry parameters. Future versions of SENTRAN7 will hopefully include

an error checking feature that warns users about physical inconsistencies created by their perturbation studies.

### 2.4.3 Refined Identification of Major Molecular Absorbers

When compiling an input file, the original SENTRAN code provided information about active molecular absorbers in the spectral region of the LOWTRAN6 calculation. However, this information was spectrally incomplete and limited to five of the twelve molecules for which absorption data are internally stored in LOWTRAN7.

For SENTRAN7, the regions of molecular absorption were refined using line parameters in MODTRAN's *BMTAPE.DAT* data file because this file provided a "quick access" to the molecular absorption data internally stored in LOWTRAN7. (The *BMTAPE.DAT* data file is an input file that accompanies the standard MODTRAN program.) Absorption data from *BMTAPE.DAT* were then condensed in an external data file called *MAJABS.DAT*. (This file is included in the SENTRAN7 package and must reside in the SENTRAN7 executable directory.)

For reference, Table 3 lists the twelve molecules for which absorption data are available in *MAJABS.DAT*. Figure 1 shows the contents of *MAJABS.DAT*. After one line of header material, the file contains three columns of data that identify the molecule, and the beginning and end integer wavenumber of its absorption band. Gaps between absorption bands of less than  $25 \text{ cm}^{-1}$  have been ignored in order to show general regions of molecular absorption, as well as reduce the size of *MAJABS.DAT*.

Regions of absorption are always displayed on the terminal during compilation, and the output can be optionally directed to a file called *SEN.ERR* (see Section 4.2.4.3). For large spectral regions, the process of displaying active molecular absorbers often exceeds the number of available lines on the screen. To compensate for this, the SENTRAN7 compiler contains a scrolling feature that allows users to view a portion of the output in a window on the terminal. Subsequent output is then displayed by hitting RETURN. Figure 2 shows how the major molecular absorbers are displayed by the SENTRAN7 compiler.

### 2.4.4 Additional Plotting Capabilities

Additional plotting capabilities have been added to SENTRAN7. Specifically, data can now be plotted from the *tape8* output files produced by LOWTRAN7. All of the currently available plots are listed in Table 4. Along with additional transmittance plots, SENTRAN7 is capable of plotting differential transmittance, black body functions, plus upward and downward fluxes. These plotting options will automatically be displayed to the user in the Graph and Analyze Module of

Table 3. List of Molecules For Which Regions of Absorption Are Displayed by the SENTRAN7 Compiler. The molecules listed here represent all of those molecules internally stored in LOWTRAN7 and MODTRAN

| NUMBER | MOLECULAR SPECIES                   |
|--------|-------------------------------------|
| 1      | Water vapor (H <sub>2</sub> O)      |
| 2      | Carbon dioxide (CO <sub>2</sub> )   |
| 3      | Ozone (O <sub>3</sub> )             |
| 4      | Nitrous oxide (N <sub>2</sub> O)    |
| 5      | Carbon monoxide (CO)                |
| 6      | Methane (CH <sub>4</sub> )          |
| 7      | Oxygen (O <sub>2</sub> )            |
| 8      | Nitric oxide (NO)                   |
| 9      | Sulphur dioxide (SO <sub>2</sub> )  |
| 10     | Nitrogen dioxide (NO <sub>2</sub> ) |
| 11     | Ammonia (NH <sub>3</sub> )          |
| 12     | Nitric acid (HNO <sub>3</sub> )     |

SENTRAN7 when choosing a plot type, if the values of IEMSCT, IMULT, and NOPRT on Card 1 are set appropriately within the Edit Module of SENTRAN7.

| 8 | 9     | 16 | 28    | 32   | 37 | 47 | 50 | 54 | 58 | 59 | 62 |
|---|-------|----|-------|------|----|----|----|----|----|----|----|
| 1 |       | 0  |       | 9508 |    |    |    |    |    |    |    |
| 1 | 9534  |    | 9625  |      |    |    |    |    |    |    |    |
| 1 | 9652  |    | 11528 |      |    |    |    |    |    |    |    |
| 1 | 11577 |    | 12938 |      |    |    |    |    |    |    |    |
| 1 | 13274 |    | 14733 |      |    |    |    |    |    |    |    |
| 1 | 14776 |    | 14776 |      |    |    |    |    |    |    |    |
| 1 | 14908 |    | 15964 |      |    |    |    |    |    |    |    |
| 1 | 16466 |    | 17880 |      |    |    |    |    |    |    |    |
| 2 |       | 1  | 9999  |      |    |    |    |    |    |    |    |
| 3 |       | 0  | 190   |      |    |    |    |    |    |    |    |
| 3 | 561   |    | 1270  |      |    |    |    |    |    |    |    |
| 3 | 1657  |    | 2269  |      |    |    |    |    |    |    |    |
| 3 | 2736  |    | 2806  |      |    |    |    |    |    |    |    |
| 3 | 2963  |    | 3056  |      |    |    |    |    |    |    |    |
| 3 | 13000 |    | 24200 |      |    |    |    |    |    |    |    |
| 3 | 27370 |    | 50000 |      |    |    |    |    |    |    |    |
| 4 |       | 1  | 70    |      |    |    |    |    |    |    |    |
| 4 | 523   |    | 752   |      |    |    |    |    |    |    |    |
| 4 | 857   |    | 1426  |      |    |    |    |    |    |    |    |
| 4 | 1580  |    | 2629  |      |    |    |    |    |    |    |    |
| 4 | 2711  |    | 2836  |      |    |    |    |    |    |    |    |
| 4 | 3293  |    | 3514  |      |    |    |    |    |    |    |    |
| 4 | 3580  |    | 3660  |      |    |    |    |    |    |    |    |
| 4 | 3691  |    | 3888  |      |    |    |    |    |    |    |    |
| 4 | 4033  |    | 4084  |      |    |    |    |    |    |    |    |
| 4 | 4309  |    | 4442  |      |    |    |    |    |    |    |    |
| 4 | 4579  |    | 4756  |      |    |    |    |    |    |    |    |
| 4 | 4952  |    | 5131  |      |    |    |    |    |    |    |    |
| 5 |       | 0  | 159   |      |    |    |    |    |    |    |    |
| 5 | 1958  |    | 2267  |      |    |    |    |    |    |    |    |
| 5 | 4041  |    | 4372  |      |    |    |    |    |    |    |    |
| 5 | 6254  |    | 6410  |      |    |    |    |    |    |    |    |
| 6 |       | 1  | 100   |      |    |    |    |    |    |    |    |
| 6 | 1043  |    | 1956  |      |    |    |    |    |    |    |    |
| 6 | 2063  |    | 3278  |      |    |    |    |    |    |    |    |
| 6 | 3876  |    | 4692  |      |    |    |    |    |    |    |    |
| 6 | 5891  |    | 6106  |      |    |    |    |    |    |    |    |
| 7 |       | 0  | 275   |      |    |    |    |    |    |    |    |
| 7 | 1407  |    | 1731  |      |    |    |    |    |    |    |    |
| 7 | 6259  |    | 6434  |      |    |    |    |    |    |    |    |
| 7 | 7665  |    | 8064  |      |    |    |    |    |    |    |    |
| 7 | 9264  |    | 9468  |      |    |    |    |    |    |    |    |
| 7 | 11459 |    | 11641 |      |    |    |    |    |    |    |    |
| 7 | 12822 |    | 13165 |      |    |    |    |    |    |    |    |
| 7 | 14293 |    | 14583 |      |    |    |    |    |    |    |    |
| 7 | 15695 |    | 15953 |      |    |    |    |    |    |    |    |
| 7 | 36000 |    | 50000 |      |    |    |    |    |    |    |    |

Figure 1. Contents of the File *MAJABS.DAT* Which Is Used To Display Regions of Active Molecular Absorption. The first record identifies the last record of absorption data for each molecule. The three columns of subsequent records represent a molecule identification number (see Table 3), and the beginning and ending frequency of a molecular absorption region.

|    |      |      |
|----|------|------|
| 8  | 0    | 98   |
| 8  | 1515 | 2141 |
| 8  | 3260 | 3991 |
| 9  | 0    | 281  |
| 9  | 433  | 617  |
| 9  | 1023 | 1419 |
| 9  | 2463 | 2526 |
| 10 | 1    | 125  |
| 10 | 585  | 986  |
| 10 | 1525 | 1682 |
| 10 | 2803 | 2938 |
| 11 | 0    | 2166 |
| 12 | 0    | 68   |
| 12 | 815  | 920  |
| 12 | 1645 | 1775 |

Figure 1. (Cont.)

```

SENTRAN7      SUN4/Unix Version      SPARTA  Inc
      DEVELOPING INPUT DECK
      BASED ON LAST EDITING SESSION

      COMPILING TEST.INP AS MESH  ERRLOG

      LIST OF ACTIVE MOLECULAR ABSORBERS (V1= 1300.0 V2= 1305.0)

      H2O  ACTIVE REGIONS:  1300.0 TO  1305.0 CM-1
      CO2  ACTIVE REGIONS:  1300.0 TO  1305.0 CM-1
      H2O  ACTIVE REGIONS:  1300.0 TO  1305.0 CM-1
      CH4  ACTIVE REGIONS:  1300.0 TO  1305.0 CM-1
      SO2  ACTIVE REGIONS:  1300.0 TO  1305.0 CM-1
      NH3  ACTIVE REGIONS:  1300.0 TO  1305.0 CM-1
      ...MORE... HIT <RETURN> TO CONTINUE

```

Figure 2. Representative Display of the Major Molecular Absorbers Used in a Given SENTRAN7 Calculation

Table 4. Plots Available From SENTRAN7's Graph and Analyze Module

| PLOT CATEGORY*                                     | SPECIFIC PLOTS  |
|--|---|
| Raw-XYZ  |   |
| Transmittance                                      | Transmittance: total, log of total, uniform mixed gases, trace gases, molecular scattering, H <sub>2</sub> O, H <sub>2</sub> O continuum, O <sub>3</sub> , N <sub>2</sub> continuum, aerosol and hydrometeor, CO <sub>2</sub> , CO, CH <sub>4</sub> , N <sub>2</sub> O, O <sub>2</sub> , NH <sub>3</sub> , NO, NO <sub>2</sub> , SO <sub>2</sub> , HNO <sub>3</sub><br>Aerosol and Hydrometeor Absorption |
| Thermal Radiance                                   | Transmittance: total, log of total<br>Atmospheric Radiance  |
| Differential Transmittance and Black Body Function | Differential Transmittance (DTAU), DTAU/layer thickness<br>DTAU×black body function,<br>DTAU×black body function/layer thickness  |
| Fluxes/Irradiance                                  | Fluxes: upward total, upward solar, downward total, downward solar<br>Direct Solar Irradiance   |
| Solar/Lunar Radiance                               | Transmittance: total, log of total<br>Radiance: total, atmospheric, path scattered, single scattered, total ground reflected, direct reflected  |
| Direct Solar Radiance                              | Transmittance: total, log of total, solar irradiance<br>Incident Solar Irradiance   |

\* Determined By Values of IEMSCT, IMULT, NOPRT on Card 1

## 2.5 New Features in SENTRAN7

### 2.5.1 Compatibility with MODTRAN

As mentioned in Chapter 1, a new feature of SENTRAN7 is the option to perform sensitivity analyses with MODTRAN. MODTRAN is an "enhanced" version of LOWTRAN7 that can compute atmospheric transmission and background radiance at resolutions between 2 and 50 cm<sup>-1</sup> Full-Width-at-Half-Maximum (FWHM). This improved spectral resolution required developing a completely new two-parameter band model algorithm; while MODTRAN and LOWTRAN share common I/O, geometry specifications, aerosol modules, etc., the two codes are **not** sequentially derivative. (see MODTRAN documentation) The input data sequence for MODTRAN is nearly identical to LOWTRAN7, although an additional input parameter on Card 4, IFWHM, defines the FWHM used to degrade MODTRAN calculations to the desired spectral resolution. Also, a logical variable, MODTRN, has been added at the beginning of Card 1 which allows MODTRAN to operate as LOWTRAN7. The format of the output files *tape7* and *tape8* from MODTRAN

is the same as that from LOWTRAN7. The MODTRAN package also requires an external data file called *BMTAPE.DAT* which contains molecular absorption parameters (see Section 2.3.3).

The ability to use MODTRAN is integrated into SENTRAN7 without compromising flexibility or power. The methodology files developed for LOWTRAN7 can be used with MODTRAN, and vice versa. Users only need to specify which code to use, and SENTRAN7 then internally keeps track of any file manipulation. When going from LOWTRAN7 to MODTRAN, however, users are reminded to define the IFWHM parameter on Card 4. The value of IFWHM is ignored when the user selects LOWTRAN7. Since SENTRAN7 uses the standard input and output format from LOWTRAN7, minor changes to MODTRAN's input format are required. For reference, the coding changes required in MODTRAN are given in Appendix B.

### 2.5.2 Addition Of An On-Line Run Module

The On-line Run Module is a new feature designed to speed up a SENTRAN7 session. In the original SENTRAN code, users had to exit the code after compiling an input file, run LOWTRAN externally, restart SENTRAN, and then enter the Graph and Analyze Module.

The On-line Run option in SENTRAN7 is achieved using a system-dependent Fortran command that "spawns" a subprocess to the computer's operating system. On VAX/VMS systems, for example, LOWTRAN7 can be executed with the command:

```
STATUS = LIB$SPAWN('run lowtran7.exe').
```

Control is returned to SENTRAN7 when the subprocess is completed. Additionally, SENTRAN7 has included an option that allows users to specify the directory where the executable LOWTRAN7 and/or MODTRAN codes reside. To do this, the users can manually edit the SENTRAN7 file called *DIRECT.ORY* which contains the directory and names of the executable codes, as well as the location of the *UFTAPE.DAT* file for MODTRAN. If *DIRECT.ORY* does not exist, SENTRAN7 searches its own directory for the appropriate files. An example *DIRECT.ORY* file has been included with the SENTRAN7 package (see Section 3.4).

### 2.5.3 Displaying Available Methodology and Other Input Files

Another new feature in SENTRAN7 is the ability to display available methodology and other input files on the screen. Effectively, the screen display is accomplished by spawning a subprocess that performs a "directory" command on all files with a common extension. SENTRAN7 displays a list of available files when users do not enter a filename (*i.e.*, pressing RETURN with no default filename)

or when a filename that does not exist is entered. After SENTRAN7 displays the available files, users can type the file they want at the bottom of the screen and then press RETURN. This feature is included in the Load/Save and Edit Modules where users must specify external input files for the Card 2C, 2D, and 3B series. An example of SENTRAN7 displaying methodology files is shown in Figure 3.

```
SENTRAN7      SUN4/Unix Version      SPARTA, Inc
                CHOOSE ONE OF THE FOLLOWING. HIT <ENTER> TO ESCAPE.
                    *.MTH

CASE0.MTH      CASE4A.MTH      DTAU.MTH      MODEL1.MTH
CASE00.MTH     CASE5.MTH      DTAU3.MTH     TEST.MTH
CASE0A.MTH     CASE5A.MTH     LAST.MTH      TUTOR1.MTH
CASE4.MTH      DEFAULT.MTH    MODEL.MTH     TUTOR2.MTH

FILE NAME : 
```

Figure 3. A Sample SENTRAN7 Screen Displaying the Available Methodology Files

### 2.5.4 Safeguards to Prevent Existing Files From Being Overwritten

SENTRAN7 includes new safeguards to prevent existing methodology files and LOWTRAN7 input files from being overwritten. The feature is operational in the Load/Save and Compile Modules when users are prompted for a filename. Before creating a methodology file (any file with the *.MTH* extension) or a LOWTRAN 7 input file (a file with a *.INP* extension), SENTRAN7 checks the current directory to see if the specified file exists. When the file is found to be present, a screen message will appear asking the user if the file can be replaced. If the user types 'n', then the user is asked to specify a different filename. An example of this new safeguard feature is given in Figure 4.

```
SENTRAN7 : SUN4/Unix Version          SPARTA, Inc
      DEVELOPING INPUT DECK
      BASED ON LAST EDITING SESSION

      ENTER FILE NAME FOR INPUT DECK [.INP]
      AND SENTRAN7 COMPILE OPTIONS

      TEST.INP

      FILE NAME EXISTS, REPLACE ? [Y]
```

Figure 4. A Sample SENTRAN7 Screen Message to Warn Users Against Writing Over Files. In this case, the user is reminded that the file, *TEST.INP*, already exists

### 2.5.5 Increased Portability Across Hardware Platforms

A new feature of SENTRAN7 is the capability to run the code on SUN Microsystems<sup>TM</sup> computers, as well as VAX/VMS computer systems. Because some new features in SENTRAN7 require system calls, the system dependent subroutines were removed from the main SENTRAN7 code and placed in separate files. Thus the SENTRAN7 package contains two files called *senvms.for* and *senunix.f*. The *senvms.for* is used when compiling and linking on VAX/VMS systems and *senunix.f* on SUN systems. Also, the current file organization readily allows for SENTRAN7 to be adapted to other operating systems, such as DOS and NOS. That is, users need only develop system dependent subroutines that perform the same actions as those in *senvms.for* and *senunix.f*.

### 2.5.6 On-line Help Within the Edit Module

An on-line help facility has been added to SENTRAN7's Edit Module. This help facility provides the user with a simple and fast method for obtaining general information about a parameter on any of the LOWTRAN7 input cards. While in the Edit Module, the user simply types 'help' on the line being edited, and a screen containing a brief description of that particular parameter will appear.

Specific examples are given in the Users Guide in Chapter 4. It should be stressed that this on-line help facility is meant only to be a quick reference into parameter definitions and possible values, and should not be used as an all-encompassing reference to the LOWTRAN7/MODTRAN variables. The user is instead referred to the appropriate manuals for LOWTRAN7<sup>1</sup> and MODTRAN.<sup>4</sup>

### **2.5.7 Tick Marks and Labeling of Plots**

The graphics produced by SENTRAN7 have been improved with the addition of tick marks on both the 2D and 3D plots, and new axis labeling at the bottom of the screen. An example of a new 3D plot is shown in Figure 5. Along with the axis tick marks, note the different format for labeling the  $x$ ,  $y$ , and  $z$  axes. The axis letter ( $x$ ,  $y$ , or  $z$ ) is given first, followed by the parameter plotted on that axis. The axis range is then displayed along with the delta value of each tick mark. If a perturbation list was used for a parameter, the list is displayed rather than the axis range, and the delta value of each tick mark is not displayed.

### **2.5.8 Plot Option for Trace Gas Profiles**

SENTRAN7 now has the ability to plot trace gas profiles from Card 2C and their perturbations. This option has been implemented in a two-step process. The user first stores the trace gas profile, and its perturbation values, if any, from within the Edit Module of SENTRAN7. Second, the user plots these data from within the Graph and Analyze Module of SENTRAN7 by choosing to plot a raw  $x$ ,  $y$ ,  $z$  data file and entering the name of the file created within the Edit Module. A more detailed description of this feature, along with an example, is given in the Users Guide in Chapters 4 of this report.

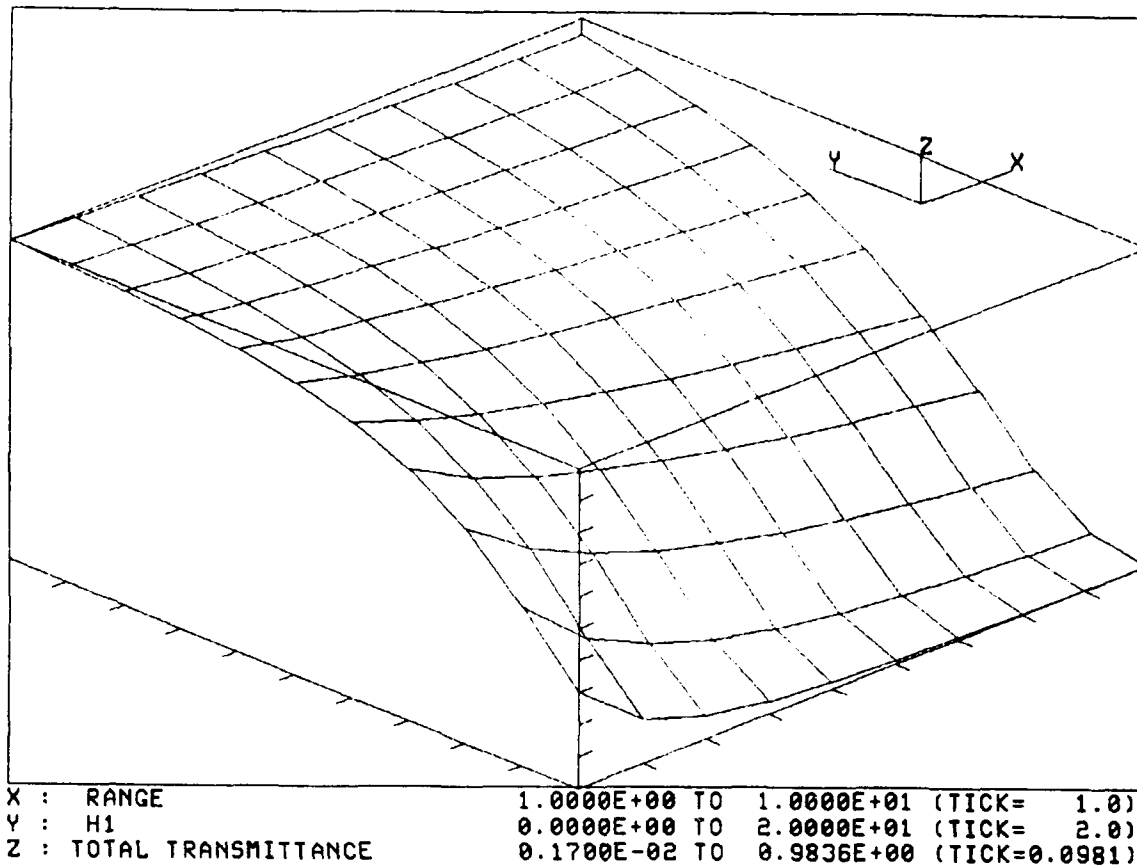

Figure 5. Example of a 3-D Plot Created by the Graph and Analyze Module of SENTRAN7

## 3 INSTALLING AND RUNNING SENTRAN7

### 3.1 Overview of Software

SENTRAN7 is designed to be highly portable, while maintaining a reasonably high level of performance. These goals dictate the use of highly portable code and common standards for graphics and terminal control. Given these requirements, SENTRAN7 is coded in Fortran-77. The code utilizes the Tektronix 4010/4014 format standards for graphics<sup>6</sup> and the American National Standards Institute (ANSI) standard for terminal control.<sup>7</sup> Tektronix 4010/4014 was selected because it is probably the most popular graphics format to be emulated. Moreover, graphics and terminal control kernels in SENTRAN7 are completely self contained, obviating the need for external software libraries. Digital Equipment Corporation's VT240 terminal (along with several VT240 compatibles available from other manufacturers) supports both the ANSI and TEK4010 standards, so it is an ideal terminal for interactive viewing of SENTRAN7 graphics. It is noted that the VT240 is, in fact, one of the industry standard graphics terminals.

### 3.2 Installing the Program

Table 5 lists the files included with the SENTRAN7 package. To install the code, first create a subdirectory to contain the programs and data files. Once this has been completed, copy the files from the distribution media into the target subdirectory.

SENTRAN7 can be compiled to run on either a VAX/VMS<sup>TM</sup> system or Sun Microsystems<sup>TM</sup> computer. The following instructions explain how to compile and link SENTRAN7:

- For a VAX/VMS system, type '@makefile'. This creates the executable file *sentran.exe*.
- For a Sun Microsystems computer, type 'make'. This creates the executable file *sentran*. Note that some Sun Microsystems computers will generate a series of warning messages during compilation which can be ignored by the user.

To start the program, the user simply types 'r *sentran*' if on a VAX/VMS system, or '*sentran*' if operating on a Sun Microsystems computer.

<sup>6</sup> Tektronix, Inc. (1977) *Users Guide and Service Manual for 4014, 4014-1 Terminals*, Tek Part No. 070-1647-00, Beaverton, OR.

<sup>7</sup> ANSI Standard X3.64 (1979) *Additional Controls for Use With ASCII*, Secretariat: CBEMA, 1828 L St., N.W., Washington, DC.

Table 5. Files Included with the SENTRAN7 Package

| FILE NAME           | CONTENTS  |
|---------------------|---|
| <i>senmain.for</i>  | Source code for SENTRAN7 (main program only)  |
| <i>sensubs.for</i>  | Source code for SENTRAN7 (other routines)   |
| <i>sennew.for</i>   | Source code for SENTRAN7 (routines created by SPARTA)   |
| <i>senvms.for</i>   | Source code for SENTRAN7 (VAX computer systems only)  |
| <i>senunix.f</i>    | Source code for SENTRAN7 (UNIX computer systems only)   |
| <i>MAJABS.DAT</i>   | Data file defining regions of molecular absorption  |
| <i>DIRECT.ORY</i>   | Configuration file containing directory and name of LOWTRAN7 and MODTRAN executables and the <i>UFTAPE.DAT</i> file. Current directory is assumed when <i>DIRECT.ORY</i> does not exist |
| <i>SETRAN.HLP</i>   | SETRAN7 on-line help utility file   |
| <i>MODEL1.PRO</i>   | Tropical atmosphere profile ( <i>i.e.</i> , Card 2C series)   |
| <i>MODEL2.PRO</i>   | Midlatitude summer profile  |
| <i>MODEL3.PRO</i>   | Midlatitude winter profile  |
| <i>MODEL4.PRO</i>   | Subarctic summer profile  |
| <i>MODEL5.PRO</i>   | Subarctic winter profile  |
| <i>MODEL6.PRO</i>   | U.S. standard profile   |
| <i>SAMPLE.AER</i>   | Sample Card 2D series: normalized aerosol extinction versus wavelength for four aerosol regions   |
| <i>SAMPLE.PHS</i>   | Sample Card 3B series: aerosol phase functions for four aerosol regions   |
| <i>DEFAULT.MTH</i>  | Sample methodology file (used in Tutorial #1)   |
| <i>lowtran7.for</i> | Source code for LOWTRAN7  |
| <i>modtran.for</i>  | Source code for MODTRAN   |
| <i>mkbin.for</i>    | Program creates <i>UFTAPE.DAT</i> from <i>BMTAPE.DAT</i>  |
| <i>makefile.com</i> | Command file for compiling and linking SENTRAN7 on VAX/VMS systems. Type '@makefile' to execute   |
| <i>makefile</i>     | Unix command file for compiling and linking SENTRAN7 on SUN systems. Type 'make' to execute   |

### 3.3 LOWTRAN7 and MODTRAN Requirements

Source codes for both LOWTRAN7 and MODTRAN have been included with this distribution. Slight modifications have been made to both source codes in order to run with SENTRAN7. The user is referred to Appendix B for a discussion of the changes. Other than the modifications specified here, no other modifications to either LOWTRAN7 or MODTRAN are allowed if they are to work with SENTRAN7.

LOWTRAN7 has been modified to continue layer-by-layer calculations even when the differential transmittance (DTAU) has become very small. In the standard version of LOWTRAN7, the program would jump out of the calculation loop when DTAU was less than  $10^{-5}$ . For SENTRAN7, however, the complete array of DTAU and flux data must be included in *tape8* to avoid empty regions or "gaps" in the 3D plots of DTAU and flux data. For reference, these code changes are given in Appendix B. The code changes to LOWTRAN7 are included with this distribution. Note that, the changes made to LOWTRAN7 are recommended changes, but are not required to run LOWTRAN7 with SENTRAN7.

MODTRAN has been similarly modified in order to continue layer-by-layer calculations even when DTAU has become very small. In addition, because the input structure for MODTRAN is slightly different from LOWTRAN7, MODTRAN must be modified slightly to work with SENTRAN7. For reference, these code changes are also given in Appendix C. The modified version of MODTRAN is included as part of the SENTRAN7 package (*modtran.for*). Note that, the changes made to MODTRAN are required in order for MODTRAN to work with SENTRAN7.

### 3.4 Using the *DIRECT.ORY* File

The *DIRECT.ORY* file allows users to specify the directory where the executable codes for LOWTRAN7 and MODTRAN reside. A sample *DIRECT.ORY* file has been included with the SENTRAN7 package. SENTRAN7 uses this file to locate the executable code for the transmission model chosen by the user. The file, *DIRECT.ORY*, should be edited with a standard text editor on the user's computer system to indicate the directories and names of the executable codes for LOWTRAN7 and MODTRAN, as well as the location of MODTRAN's molecular absorption data file called *UFTAPE.DAT*. Note that if *DIRECT.ORY* does not exist, SENTRAN7 searches the current directory for the appropriate files.

## **4 USERS GUIDE FOR SENTRAN 7**

This users guide is targeted at both novice and experienced SENTRAN7 users, and provides an overview of SENTRAN7's structure and usage. Details of command usage in a quick reference format, may be found in Appendix C. Recall that SENTRAN7 can execute either LOWTRAN7 or MODTRAN. Unless explicitly stated, the use of the term LOWTRAN7 will imply reference to both LOWTRAN7 and MODTRAN.

### **4.1 Overview of SENTRAN7**

A brief overview of SENTRAN7 is given in this section for users who are not familiar with the original SENTRAN code. Users who are familiar with the features of the original SENTRAN may skip this section and proceed to Section 4.2.

#### **4.1.1 Code Philosophy**

SENRAN7 is a general purpose computer code that facilitates the analysis of LOWTRAN7's response to the perturbation of its input parameters. SENTRAN7 is primarily designed as a comfortable, interactive interface to LOWTRAN7 with special provisions for perturbation analysis. Using SENTRAN7, one can easily extract, analyze, reduce, and plot LOWTRAN7 data. These features permit users to rapidly perform analyses that would be difficult or impossible through brute-force techniques. The process is highly automated and requires little effort on the part of the user because SENTRAN7 is "intelligent" enough to keep track of the details of parameter variation. Also, SENTRAN7 contains many useful analysis tools such as evaluating partial derivatives of a variable represented by the  $z$  axis with respect to two independent variables given by the  $x$  and  $y$  axes. Using these capabilities, users can rapidly determine those regions where LOWTRAN7's calculations are most sensitive.

SENRAN7 makes extensive use of graphics to display results. The human eye possesses strong abilities with respect to trend analysis and can identify complicated patterns at a glance. These capabilities are fully exploited in SENTRAN7 via the use of 3D surface plots, enabling users to visualize LOWTRAN7's response to the simultaneous variation of two parameters. These plots can be archived as files for hard-copy generation and/or later perusal on a graphics terminal.

#### **4.1.2 Design Criteria**

The design of SENTRAN7 was based on the following general criteria:

1. User friendliness
2. Framework for sensitivity analyses
3. High portability

4. Quick turnaround time for interactive analyses
5. Extensive use of graphics for data presentation
6. Provisions for data analysis and reduction tools.

User friendliness is one of the single greatest considerations in SENTRAN7's design. Most of SENTRAN7 is devoted to providing users with a comfortable working environment, without compromising flexibility or power. User friendliness is implemented in a number of ways, including:

1. The code is virtually crash proof, using character oriented input for command strings and numerical values. Before being accepted, numerical inputs are examined to make sure they are physically meaningful.
2. Commands can be entered in upper, lower, or mixed case.
3. Abundant feedback is provided, including step-by-step prompts and ample information when the code cannot properly read user-specified input files.
4. The command interpreter can resolve the component parts of complicated input strings, bypassing input prompts, thus permitting veteran users to use the code with increased speed.
5. Sensible defaults are provided wherever possible, reducing the chance of erroneous input.
6. On-line help is available, minimizing the amount of time required to learn how to use SENTRAN7. The help feature also provides information on LOWTRAN7 inputs.

While this list is by no means complete, it provides an idea of the user friendly features of SENTRAN7. Collectively, these features eliminate the need to concentrate on file and data manipulation so users can focus on the scientific aspects of their LOWTRAN7 analysis problems.

Another important requirement is the ease and speed of post-processing of LOWTRAN7 outputs. SENTRAN7 tries to isolate LOWTRAN7 from the user as much as possible so that the user need not be aggravated by bookkeeping. It can extract transmittance and/or radiance data from LOWTRAN7's *tape7* and *tape8* output files. Also, SENTRAN7 is intelligent enough to prompt the user with the list of input parameters that can be chosen as independent variables for plotting and derivative computation.

Data analysis and reduction tools are provided along with graphics in an interactive module. The analysis tools include common data manipulations such as logarithmic transformation of data and partial derivatives of first and second order with respect to the independent axes. Furthermore, SENTRAN7 can read and

plot raw data files as well as output the reduced data as raw data files for use in commercial plotting packages.

## **4.2 Program Structure**

SENTRAN7 is structured into a number of subprograms called modules. Each module performs a specific task to aid users in their sensitivity studies. The modules are ordered according to the way users would typically conduct a sensitivity study. The seven main modules of SENTRAN7 are listed in Table 6. The SENTRAN7 Main Menu is shown in Figure 6. The following sections provide specific details on how to use each of the SENTRAN7 modules.

### **4.2.1 Help Module**

On-line help is available at almost all locations within the SENTRAN7 program. Specifically, help information is available at the Main Menu, within the Edit Module, and within the Graph & Analyze Module of SENTRAN7. At the Main Menu, users can obtain general information about most of SENTRAN7's modules listed in Table 6. To access this information, the user enters the command '**help**' followed by a module name when at the Main Menu screen. For example, the user could enter '**help load**' for a description of the LOAD command. In the absence of a module name, an introductory help screen appears which displays a list of help topics (see Figure 7). Users can then enter the name of a selected topic, whereupon they will receive help on that particular topic. If the user does not select a topic, or selects an invalid topic, control will return to the Main Menu. This general Help Module has not been updated yet to supply information on the new Select and Run Modules of SENTRAN7. On-line help is also available in the Edit Module and the Graph and Analyze Module of SENTRAN7. These on-line help capabilities are described in greater detail in Sections 4.2.3.5 and 4.2.7.5, respectively.

### **4.2.2 Load/Save Module**

In SENTRAN7, images of LOWTRAN7 input parameters and commands for their perturbation are contained in files known as "methodology" files. These files are stored on the host computer with *.MTH* extensions. Methodology files enable users to store various methodologies and use them as starting points for new experiments. A more detailed description of a methodology file is given in Appendix A.

The Load/Save Module is where users can load and save selected methodology files. To load a methodology file, the user enters '**1**' or '**load**' at the Main Menu prompt. If the user enters '**1**', SENTRAN7 will ask the user whether they want to load or save a methodology file. The user then enters '**load**' or simply '**1**', in order to load a file. The program will then display a list of all files with a

Table 6. List of SENTRAN7 Modules

| MODULE            | MAIN FUNCTION   |
|-------------------|---|
| Help              | Provides help for SENTRAN7 users  |
| Load/Save         | Loads and saves SENTRAN7 methodology files  |
| Edit              | Permits users to define their LOWTRAN7 problems, including atmospheric inputs and commands for their perturbation |
| Compile           | Creates LOWTRAN7 input file based on editing session and displays major molecular absorbers                       |
| Select            | Selects code to be used: LOWTRAN7, MODTRAN or MODTRAN run as LOWTRAN7   |
| Run               | Executes selected code, and creates LOWTRAN7's <i>tape7</i> and <i>tape8</i> files                                |
| Graph and Analyze | Extracts output data, analyzes and graphs, and reduces data I/O   |

```

SENTRAN7      SUN4/Unix Version      SPARTA  Inc
                WELCOME TO SENTRAN7
                THE SENSITIVITY ANALYSIS PROGRAM FOR LOWTRAN7/MODTRAN

                1 - LOAD/SAVE
                2 - EDIT
                3 - COMPILE
                4 - SELECT LOWTRAN7/MODTRAN
                5 - RUN LOWTRAN7
                6 - GRAPH & ANALYZE
                7 - HELP
                8 - QUIT
    
```

Figure 6. SENTRAN7 Main Menu

```
SENTRAN7      SUN4/Unix Version      SPARTA, Inc
SENTRAN7 ONLINE HELP UTILITY

HELP IS AVAILABLE ON THE FOLLOWING TOPICS :

      LOAD      SAVE      EDIT
      COMPILE   GRAPH   ANALYZE
      SEARCH    ZAP      LOG

ENTER THE NAME OF THE SUBJECT FOR WHICH YOU NEED HELP
OR PRESS <RETURN> TO RETURN TO MAIN PROGRAM

NOTE:   THE HELP COMMAND ACCEPTS THE ABOVE ITEMS AS
        ARGUMENTS, BYPASSING THIS SCREEN
        EXAMPLE: HELP EDIT

HELP 
```

Figure 7. The Introductory Help Screen in the Help Module

*.MTH* extension present in the current directory and will prompt the user for the file name to load. If the user knows which methodology file they wish to load at the Main Menu, several steps can be saved by simply entering 'load *filename*' at the Main Menu prompt, where *filename* is the methodology file name to load into SENTRAN7. Recall that a *.MTH* extension is presumed on methodology files unless the user specifies a different extension. For example, typing 'load example' will load a file named *EXAMPLE.MTH*, while typing 'load wierd.ext' will load a file named *WIIRD.EXT*.

Similarly, if the user wishes to save the current values of all the parameters set within the Edit Module, to a methodology file, the user enters '1' or 'save' at the Main Menu prompt. If the user enters '1', save option must be selected. The user is then prompted for the name of the methodology file to save the current parameter values in. This file is also given a *.MTH* default extension unless a different extension is specified by the user. If the file already exists, the user must confirm that the file is to be overwritten. If the user enters 'n', program control will be returned to the Main Menu and the methodology file will not be overwritten. Saving methodology files allows the user to easily restore the parameters used for a given simulation.

It is worth noting that the current values of the parameters set within the Edit

Module are saved to a special file, *LAST.MTH*, after every completed editing session (*i.e.*, an editing session in which the user does not proceed to the Main Menu via the END command) and after every compilation. This file is loaded into SENTRAN7 at the beginning of the next SENTRAN7 session and provides a default methodology for the session. Therefore, users are cautioned against saving methodology files named *LAST.MTH*, or tampering with the *LAST.MTH* file in any way.

### 4.2.3 Edit Module

The Edit Module of SENTRAN7 provides a flexible means of defining LOWTRAN7 input cards. The SENTRAN7 editor permits the entry of atmospheric data and commands for data perturbation. The user is reminded that LOWTRAN7's input philosophy is based on "cards" of data. Each "card" relates to data or operating conditions of a specific type. SENTRAN7 retains the LOWTRAN7 input card philosophy and SENTRAN7's editor emulates LOWTRAN7's logical flow through the input card images.

#### 4.2.3.1 Using the Edit Module

To enter the editor, the user should enter '2' or 'edit' at the Main Menu prompt. The SENTRAN7 Edit Module then provides the user with a series of screens from which the user can set up or edit the simulation conditions. Figure 8 provides an example of a screen displayed while editing a LOWTRAN7 "card." The example is for Card 1 of the LOWTRAN7 input cards. The name of the current card image appears at the top of the editing screen, while the name of the LOWTRAN7 input variables appear along the left hand column. Values for each of the LOWTRAN7 inputs appear to the immediate right of the list of names, along with any perturbation instructions. The terminal's cursor will appear to the left of the variable which is currently being edited, and data entry is accomplished by typing over the current field. In Figure 8, MODEL is the parameter currently being edited. Variables that are marked with an "\*" are subject to certain restrictions. As discussed in Section 2.2, the input parameters marked with an "\*" in the Edit Module, cannot be perturbed in some cases because their perturbation creates different flows through the input card images. These input parameters have been previously listed in Table 1.

#### 4.2.3.2 Movement Through the Edit Module

In the Edit Module, the user hits RETURN to move down the current card image, line-by-line. In addition, there are several input strings that SENTRAN7 reserves for cursor control. These commands are listed in Table 8. Note in Table 8, that the "n" values are optional, and their absence implies  $n=1$ .

```

SENTRAN7      SUN4/Unix Version      SPARTA, Inc
                SENTRAN7 EDITING UTILITY
                EDITING CARD 1

FOLLOWING PARAMS. USE A PERTURBATION LIST (* IMPLIES PERTURBATION RESTRICTIONS)

MODEL *  6 3 2 1
ITYPE * 1
ITEMSCT* 0
IMULT * 0
M1 ... 0
M2 ... 0
M3 ... 0
M4 ... 0
M5 ... 0
M6 ... 0
MDEF... 0
IM ... * 0
NOPRT * 0

FOLLOWING PARAMS. USE A PERTURBATION VALUE
TBOUND      0.000
SALB        0.000

```

Figure 8. An Example of a Screen from SENTRAN7 Editing Module

Table 7. List of Cursor Control Commands in the Edit Module of SENTRAN7

| COMMAND         | ACTION   |
|-----------------|--|
| <b>up</b> $n^1$ | Move cursor up $n$ lines                                 |
| <b>dn</b> $n$   | Move cursor down $n$ lines                               |
| <b>pu</b>       | Move to previous major <sup>2</sup> card image (PAGE UP) |
| <b>pd</b>       | Move to next major card image (PAGE DOWN)                |
| <b>end</b>      | End editing session, goto Main Menu                      |

<sup>1</sup>  $n$  is optional; its absence means  $n = 1$

<sup>2</sup> Major cards are Card 1, 2, 3, 4

While in the Edit Module, the user can use the "UP" command to go back to a previous parameter. Simply typing 'up' and RETURN will move the cursor up one line. To move back more than one line, the user should enter 'up' and the number of lines to move. For example, the command, 'up 2', will move the cursor back two lines. Similarly, to move ahead, the user should enter the "down" command, 'dn', and the number of lines to move down (if greater than one).

If the user has made all the necessary changes to a card and wants to move quickly to the next card image, the "PAGE DOWN" command, 'pd', is used. Before proceeding to the next card image, the user will be prompted to check that all the parameters on the current card have been set as desired. Similarly, if the user wants to move back to the previous card image, the PAGE UP command, 'pu', is used. This command will move the user to the previous major card image. Note that the major cards are Cards 1, 2, 3, and 4. To quickly end the editing session, the user enters 'end' and RETURN. The user is then returned to the Main Menu.

As editing is taking place, the user will notice that some LOWTRAN7 input cards and some variables within a card will not be made available for editing. Instead, the cursor will skip over certain parameters or certain input cards will not be displayed. This is because SENTRAN7's editor emulates LOWTRAN7's flow through input cards. Specifically, some LOWTRAN7 parameters are not available unless certain other conditions have already been set. For example, on Card 1, if the execution mode parameter (IEMSCT) is set for transmittance mode (IEMSCT=0) or directly transmitted solar irradiance (IEMSCT=3), then multiple scattering is not allowed. Therefore, the IMULT parameter, which specifies multiple scattering, is set to zero and SENTRAN7 does not let the user edit this parameter. This feature aids the user by eliminating unnecessary and potentially misleading inputs. In addition, the user is not asked to edit certain cards unless they are needed. For example, Card 2C is not edited unless the model parameter is set for meteorological data (MODEL=0) or a new model atmosphere (MODEL=7) and radiosonde data are to be read in at execution time (IM=1). This again eliminates unnecessary input and serves as a form of debugging tool, in that the user who wants to edit a certain card image is first forced to set the appropriate flag on a previous card image as required by LOWTRAN7.

It is important to note that if the user tries to move up or down via the 'up' and 'dn' commands to a line that cannot be edited, the cursor will not move from the current line. The user must enter a number of lines to move with the 'up' and 'dn' commands so that the cursor will be placed on a line that can be edited.

After each card has been edited, the user is prompted to check that all the parameters for that card have been set as desired, as shown in Figure 9. Before

proceeding to the next card image, the user should check the values set for the current card. If the user wants to change a value, the user can enter 'n' to return to the top of the card being edited. If the user accepts the default 'y', the screen is updated to display the next card image to be edited.

```

SENTRAN7 : SUN4/Unix Version                               SPARTA, Inc
                SENTRAN7 EDITING UTILITY
                EDITING CARD 1

FOLLOWING PARAMS. USE A PERTURBATION LIST (* IMPLIES PERTURBATION RESTRICTIONS)

MODEL *        6
ITYPE *        1
IEMSCT*        0
IMULT *        0
M1 ...         0
M2 ...         0
M3 ...         0
M4 ...         0
M5 ...         0
M6 ...         0
MDEF ..        0
IM ... *       0
NOPRT *        0

FOLLOWING PARAMS. USE A PERTURBATION VALUE
TBOUND         0.000
SALB           0.000
ALL PARAMETERS FOR CARD 1 O.K. (Y/N) [Y]

```

Figure 9. Prompt to Check the Variables on a Given LOWTRAN7 Input Card. The example given is for Card 1

#### 4.2.3.3 Data Entry in the Edit Module

Entry at each line of a card image consists of two elements. The first is known as the nominal value, while the second is known as a perturbation directive. The nominal value, in the absence of a perturbation directive, is the value which SENTRAN7 passes to LOWTRAN7 upon execution. The perturbation directive is a statement which is interpreted by SENTRAN7's Compiler Module to produce a sequence of values to use for that particular parameter during a LOWTRAN7 run. The nominal value, in the presence of a perturbation directive, is the value perturbed.

Data entry is accomplished by simply typing over the current field. Note that SENTRAN7 is case insensitive and, therefore, data entry can be accomplished in either lower or upper case. After the input line is entered, SENTRAN7 internally converts the string to upper case and displays the line in a special format, insuring an organized appearance for the editing screens.

#### 4.2.3.4 Perturbing Data in the Edit Module

SENTRAN7 permits symbolic manipulation of input card variables through a simple interpreted language data entry format. Five basic perturbation syntaxes are supported, each possessing a different physical interpretation, allowing the user to select the syntax which best fits the user's needs. The syntaxes supported are shown in Table 8. The nominal value is the first value entered in the command. Terms appearing in square brackets "[ ]" in Table 8 are optional. The '%', '+/-', 'TO', and '\*' terms are actual elements within the command string. Type these commands exactly as they appear. Examples of the perturbation commands and how they can be used, are shown in Table 9. (Note that these perturbations are not limited to the parameters shown in Table 9. These parameters were chosen only to give specific examples of how each of the perturbation commands can be used.)

Table 8. List of SENTRAN7 Perturbation Directive Syntaxes in the Edit Module

| TYPE OF PERTURBATION | SYNTAX FORMAT  |
|----------------------|--|
| % <sup>1</sup>       | <i>nominal value %value</i>                                |
| +/-                  | <i>nominal value +/- value</i>                             |
| Iteration            | <i>nominal value [start]<sup>2</sup> TO final [STEP n]</i> |
| List                 | <i>nominal value value2 value3 ...</i>                     |
| Use Previous         | <i>nominal value *</i>                                     |

<sup>1</sup> On Card 2C and 2D, a nominal value is not allowed with a percent perturbation

<sup>2</sup> Terms in "[ ]" are optional

To produce a percent perturbation of a parameter, the user first types a nominal value followed by a '%' sign and the amount of the percent perturbation. For example, to perturb the parameter H1 on Card 3, with a nominal value of 5.0 by 20 percent, the user would enter the command '5.0 %20', as shown in the first example in Table 9. When compiled, the input file contains LOWTRAN7 input conditions for the H1 parameter at 4.0, 5.0, and 6.0 km. Note that for Cards 2C and 2D, where only percent perturbations are allowed, the user does not enter a nominal value. Instead, the user need only enter '%' followed by the amount of the desired percent perturbation. The nominal values are read from the input files provided for Cards 2C and 2D, the trace gas and aerosol attenuation profiles, respectively.

Table 9. Examples of Perturbation Directives

| SAMPLE<br>PARAMETER | PERTUBATION<br>DIRECTIVE | SEQUENCE<br>PRODUCED |
|---------------------|--------------------------|----------------------|
| H1                  | 5.0 %20                  | 4.0, 5.0, 6.0        |
| H2                  | 8.0 +/- 2                | 6.0, 8.0, 10.0       |
| ANGLE               | 45.0 TO 47               | 45.0, 46.0, 47.0     |
| RANGE               | 10.0 TO 20 STEP 5        | 10.0, 15.0, 20.0     |
| VIS                 | 5.0 0 TO 10 STEP 5       | 0.0, 5.0, 10.0       |
| MODEL               | 4 3 6                    | 4, 3, 6              |

The second perturbation type allows the user to explicitly specify an offset to the nominal value. In this case, the user enters the nominal value and then '+/-' followed by the offset value. For example, to perturb the parameter H2 on Card 3 with a nominal value of 8.0 by  $\pm 2$ , the user would enter '8.0 +/- 2', as shown in the example in Table 9. This command would produce the sequence "6.0, 8.0, 10.0" for the H2 parameter.

The user can also specify an iterative perturbation by entering a start and final value and a step size, with the default step size being equal to one. One example of this type of perturbation is shown in Table 9 for the ANGLE parameter on Card 3. For example, if the user enters the command '45.0 TO 47' for the ANGLE parameter, LOWTRAN7 will perform calculations with the parameter ANGLE set at 45.0, 46.0, and 47.0 degrees. The user can also explicitly specify a step size for the iterative perturbation, as shown in the example in Table 9 for the RANGE parameter on Card 3. In this example, the user would enter '10.0 TO 20 STEP 5', to produce the sequence "10.0, 15.0, 20.0". Note that the nominal value for the iterative perturbation, can be different than the start value of the iteration. An example of this is shown for the VIS parameter in Table 9. In this example, the user would specify a nominal value of 5.0km for the visibility (the VIS parameter on Card 2), and then perturbs the parameter from 0 to 10km, in steps of five. The command the user enters is '5.0 0 TO 10 STEP 5'. The benefits of specifying a different nominal value will become clear when the compiler options are explained in Section 4.2.4.2. Briefly, the NOMESH option of the SENTRAN7 compiler, perturbs one parameter at a time, holding all other parameters fixed at their nominal values. In the example given here, the VIS parameter will be held constant at 5.0 while other parameters are perturbed. If the user had entered '0 TO 10 STEP 5'

for the VIS parameter, with no nominal value specified, then the VIS parameter would be held constant at 0.0 while other parameters were perturbed, if compiled with the NOMESH option. Thus, the user may want the nominal value to be different than the starting value of the iteration.

The fourth type of perturbation is to enter a specific list of values. In this case, the user would simply type in the values to use, separated by spaces. This is shown in an example in Table 9 for specifying different model atmospheres using the MODEL parameter from Card 1.

The last type of perturbation listed in Table 8 allows the user to change the nominal value of a parameter, but keep the old perturbation for that parameter. The user should enter the new nominal value followed by a '\*'. For example, to change the nominal value of a particular parameter to 5.0, but keep the previously specified perturbation directive, the user should enter '5 \*'. An example of this command is not shown in Table 9 because the sequence produced with this type of perturbation depends on the previously set perturbation directive.

It should be noted that the Edit Module checks that the nominal value entered by the user is within the allowable range for that particular parameter. This is done after the user presses return. If the value entered by the user is out of range, SENTRAN7 sets the nominal value to the nearest value within range. The user is cautioned that no warning message is given, therefore it is important that the user verify each line after it has been entered. Although the Edit Module checks the nominal value, it does **not** check that the perturbed values for a particular parameter are physically meaningful and within range. The perturbation values will, instead, be checked within the Compiler Module which will issue a warning to the user at that time.

#### **4.2.3.5 On-line Help Utility Within the Edit Module**

A help utility has been added to the Edit Module of SENTRAN7. This help facility provides the user with a simple and fast method for obtaining general information about a parameter on any of the LOWTRAN7 input cards. While in the Edit Module, the user simply types 'help' on the line being edited, and a screen containing a brief description of that particular parameter will appear. Figure 10 shows an example, when the user types 'help' while editing the MODEL parameter on Card 1. It should be stressed that this on-line help facility is meant only to be a quick reference into parameter definitions and possible values and should not be used to understand the overall meaning of the LOWTRAN7 variables. The user is, instead, referenced to the appropriate user guides for LOWTRAN7<sup>1</sup> and MODTRAN.<sup>4</sup>

```

SENTRAN7 : SUN4/Unix Version          SPARTA, Inc
SENTRAN7 EDITING UTILITY
EDITING CARD 1

FOLLOWING PARAMS. USE A PERTURBATION LIST (* IMPLIES PERTURBATION RESTRICTIONS)

MODEL * help0
ITYPE *      1
IEMSC*      0
IMULT *      ^

M1 .. SENTRAN7 : SUN4/Unix Version          SPARTA, Inc
M2 .. SENTRAN HELP UTILITY
M3 ..
M4 .. 'MODEL'                                CARD 1
M5 ..
M6 ..
MDEF .. SELECTS ONE OF THE SIX GEOGRAPHICAL-SEASONAL MODEL ATMOSPHERES OR
IM .. SPECIFIES THAT USER-DEFINED METEOROLOGICAL DATA ARE TO BE USED:
NOPR ..
        = 0 METEOROLOGICAL DATA (HORIZONTAL PATH ONLY)
        1 TROPICAL ATMOSPHERE
        2 MIDLATITUDE SUMMER
        3 MIDLATITUDE WINTER
        4 SUBARCTIC SUMMER
        5 SUBARCTIC WINTER
        6 1976 U.S. STANDARD ATMOSPHERE
        7 NEW MODEL ATMOSPHERE (OR RADIOSONDE DATA)

FOLLK
TBOU
SALB

HIT <RETURN> TO CONTINUE

```

Figure 10. On-line Help Screen Within Editing Module of SENTRAN7. (Note that the help screen does not appear as a partial overlay during execution as shown in this figure, but rather covers the entire screen)

#### 4.2.3.6 Notes About the Edit Module

It is important to note that SENTRAN7 often rounds off numbers incorrectly when displaying nominal values in the Edit Module. This is due to the rounding procedure used in the Edit Module's output format routine. That is, SENTRAN7 utilizes internal character manipulation routines which mimic Fortran format statements, permitting flexible reformatting and mixing of character and numerical data. Often, SENTRAN7 will display a number incorrectly, terminating the number with a set of trailing 9's. For example the value 70 may be displayed as 69.99. While this problem may be disconcerting (*i.e.*, the number typed is not the number observed) the internal representation of the number is correct and the bug can safely be ignored. An example of this is shown in the tutorials in Chapter 5.

#### 4.2.4 Compile Module

Once data have been entered or edited, it must be compiled, or prepared for assembly as an input file for LOWTRAN7. This is accomplished by SENTRAN7's Compile Module. The SENTRAN7 compiler performs four distinct functions:

1. It generates LOWTRAN7 input files by interpreting edited input according to a special data generation syntax
2. It provides a list of active molecular absorbers within the spectral region of the LOWTRAN7 calculation
3. It automatically generates a methodology file with the same first name as the input file generated (example: typing the command '**compile example**' produces two files, *EXAMPLE.INP* and *EXAMPLE.MTH*, as a LOWTRAN7 input file and methodology file, respectively)
4. It optionally generates a special debug file called *SEN.ERR*.

##### 4.2.4.1 Invoking the Compile Module

Like most of SENTRAN7's main functions, the SENTRAN7 compiler is invoked from the Main Menu, either by typing '3', or any sub-string of the word '**compile**', such as 'c'. The user has the option of imbedding compiler arguments (*i.e.*, the input file name and compiler options) within the initial command string, or of being prompted for them on a step-by-step basis. Table 10 shows the allowable compiler commands as typed from the Main Menu and Table 11 gives examples of compiler commands and their effect.

Table 10. Allowable Compiler Commands As Typed From the Main Menu

|   |
|---|
| <b>compile</b> [ <i>input file name</i> ] [/MESH /NOMESH /ERROR]                      |
| or  |
| <b>3</b> [ <i>carriage return</i> ] [ <i>input file name</i> ] [/MESH /NOMESH /ERROR] |

**/MESH** Generates All Possible Combinations of Perturbed Input Parameters

**/NOMESH** Perturbs One Parameter at a Time, Holding All Others Fixed

**/ERROR** Creates *SEN.ERR* Containing Compile Errors and List of Active Molecular Absorbers

Table 11. Examples of Compiler Commands as Typed From the Main Menu

| COMMAND                             | EFFECT  |
|-------------------------------------|---|
| <b>compile test /m /e</b>           | Compiles input file named <i>TEST.INP</i> as MESH and generates the error file <i>SEN.ERR</i>   |
| <b>3 &lt;RETURN&gt;<br/>test /n</b> | Compiles input file named <i>TEST.INP</i> as NOMESH with no error file  |
| <b>com test.wow</b>                 | Compiles input file named <i>TEST.WOW</i> using last mode (MESH or NOMESH) as default, no error file generated  |
| <b>c test.dumb /m /n /e</b>         | Compiles input file named <i>TEST.DUMB</i> as NOMESH, demonstrating that MESH and NOMESH are exclusive, with NOMESH taking precedence. An error file is created |

#### 4.2.4.2 MESH and NOMESH Compiler Options

SENTRAN7's compiler supports two options which control how many separate LOWTRAN7 runs are created in the input file. These are the MESH and NOMESH options. To include the MESH option, the user enters '/mesh', or simply '/m', after the name of the input file to be created by the SENTRAN7 compiler. Similarly, to include the NOMESH option, the user enters '/nomesh', or simply '/n', after the input file name. Note that the MESH and NOMESH options are exclusive, that is, only one can be used for compiling an input file. If both options are specified, the NOMESH option takes precedence and the input file will be compiled as NOMESH. Another fact worth noting is that the SENTRAN7 compiler "remembers" the last compilation mode selected and utilizes this as the default mode for subsequent compilation if neither the MESH or NOMESH options are specified.

The MESH option generates all possible combinations of all perturbed input parameters while the NOMESH option perturbs one parameter at a time, holding all other parameters fixed at their nominal values. The difference between the MESH and NOMESH options can be demonstrated in Table 12 which shows the combinations of LOWTRAN7 runs that will be generated by SENTRAN7 when two parameters are simultaneously perturbed. In this example, both parameters are given a nominal value and three perturbation values. A 'M/N' means both the MESH and NOMESH options generate this combination for a LOWTRAN7 run. An 'M' means only the MESH option will compile this combination. The MESH option is most useful for studying synergistic effects arising from the simultaneous perturbation of several parameters, while the NOMESH option generates a smaller data set if more than one parameter is perturbed. If only one parameter is perturbed,

Table 12. An Example of Combinations of LOWTRAN7 Runs for the MESH and NOMESH Compiler Options When Two Parameters Are Perturbed. In this example, both parameters have a nominal value and three perturbations

| FIRST<br>PARAMETER | SECOND PARAMETER |                |                |                |
|--------------------|------------------|----------------|----------------|----------------|
|                    | Nominal Value    | Perturbation 1 | Perturbation 2 | Perturbation 3 |
| Nominal Value      | M/N <sup>1</sup> | M/N            | M/N            | M/N            |
| Perturbation 1     | M/N              | M <sup>2</sup> | M              | M              |
| Perturbation 2     | M/N              | M              | M              | M              |
| Perturbation 3     | M/N              | M              | M              | M              |

<sup>1</sup> 'M/N' indicates both the MESH and NOMESH options generate this LOWTRAN7 run

<sup>2</sup> 'M' indicates the MESH option only will generate this LOWTRAN7 run

or no parameters are perturbed, the MESH and NOMESH options are equivalent.

SENTRAN7 places few restrictions on the number of parameters that may be perturbed, although the compiler insures that perturbed values for a particular parameter are physically meaningful. Up to 10 simultaneous perturbations may be realized for each compilation, with each perturbation assuming as many as 100 distinct values (more than 100 distinct values can be generated for each variable in NOMESH form). This feature permits extremely rapid exploration of the sensitivity of different LOWTRAN7 parameters, with the unfortunate side effect of generating enormous quantities of output. In fact, SENTRAN7's capability to generate multiple runs of LOWTRAN7 far outweigh its analysis capabilities, since SENTRAN7 can only graph and analyze the effects of two simultaneous perturbations at a time.

#### 4.2.4.3 Error File Option

Another option supported by SENTRAN7's compiler is the ability to write SENTRAN7 compiler error messages and information on major absorbers within the current spectral interval to a special file. This is the ERROR option in the SENTRAN7 Compiler Module. To include the ERROR option, the user enters '/error', or simply '/e', after the name of the input file to be created by the SENTRAN7 compiler. The ERROR option can be used in combination with the MESH or NOMESH options, or alone.

Selection of the ERROR option causes a list of active absorbers and their spectral range of activity to be written to a file called *SEN.ERR*, along with any compile time errors. As mentioned previously, the SENTRAN7 Compiler Module checks

that the perturbed values of each parameter are within range for that particular parameter. If there are values that are not within range, the Compiler Module will issue a warning to the user on the screen indicating the parameter and the value out of range. These error messages can also be written to the file, *SEN.ERR*, by indicating the '/error' option when entering the input file name and compiler options. Thus, the ERROR option serves as a crude analysis tool, as well as a potentially useful debugging aid.

#### 4.2.5 Select Module

The Main Menu Select Module is a new feature in SENTRAN7 which allows the user to specify which transmission model to be used in their sensitivity analyses. The user can select from LOWTRAN7, MODTRAN, or MODTRAN run as LOWTRAN7. SENTRAN7 methodology files will work with any of these options. In order to enter the Select Module the user types '4' or 'select' at the Main Menu command line. A submenu will appear, as shown in Figure 11, for choosing which model to run. Enter '1', '2' or '3' in order to run LOWTRAN7, MODTRAN or MODTRAN AS LOWTRAN7, respectively. Note that this option does not actually execute the model code, but instead simply chooses which model will be executed from the Run Module (see Section 4.2.6). After a selection is made, SENTRAN7 internally confirms that the specified executable code exists. To do this, SENTRAN7 checks the configuration file, *DIRECT.ORY*, which contains the directory and names of the LOWTRAN7 and MODTRAN executable codes, as well as the location of MODTRAN's molecular absorption data file called *UF-TAPE.DAT*. (Refer to Section 3.4 for more information about the *DIRECT.ORY* file.) SENTRAN7 warns the user if the executable file cannot be found. The user must then exit SENTRAN7 and edit the file *DIRECT.ORY* to correctly indicate where the transmission model executable file is located. If *DIRECT.ORY* does not exist, SENTRAN7 searches the current directory for the appropriate files. Once a model code has been correctly selected, SENTRAN7 returns to the Main Menu.

#### 4.2.6 Run Module

The Run Module, a new feature in SENTRAN7, executes the transmission model as specified in the Select Module. The default calculations are performed using the most recent input file to be compiled, although users can specify any input file upon entering the Run Module. The Run Module produces the standard LOWTRAN7 output files named *tape7* and *tape8* which can then be interrogated in the Graph and Analyze Module.

To select the Run Module, the user simply types in '5' or 'run' at the main command line prompt. SENTRAN7 will then prompt the user for the input file to use, with the default being the last input file compiled. To return to the Main Menu,

```
SENTRAN7  SUN4/Unix Version  SPARTA, Inc
                SELECT LOWTRAN7/MODTRAN
                CURRENT MODE OF EXECUTION :  LOWTRAN7

                1 - LOWTRAN7
                2 - MODTRAN
                3 - MODTRAN AS LOWTRAN7

                ? 
```

Figure 11. SENTRAN7 Screen Displaying the Choices of Model Programs to Execute

without executing LOWTRAN7 or MODTRAN, type in 'pu' for "page up" at the prompt for an input file name. This will return the user to the Main Menu. To accept the default input file name, the user simply hits RETURN. To enter a new input file, type in the new file name and then hit RETURN. A default extension of *.INP* is appended to the file name if no extension is given. Once the user has chosen an input file, SENTRAN7 will execute the selected model code and ask the user to please wait until execution is completed. The time required to complete a run will depend on many factors, such as the speed of the host computer and the type of calculation. Once the calculations are completed, the user hits RETURN to continue and is returned to the Main Menu.

#### 4.2.7 Graph and Analyze Module

The Graph and Analyze (G&A) Module in SENTRAN7 provides the user with a powerful tool for analyzing results from a LOWTRAN7 simulation. The options available with the G&A Module allow the user to display and manipulate the output from a given simulation. In particular, the G&A Module provides:

1. Flexible options for extracting and displaying output from LOWTRAN7 calculations and various input files.
2. Tools for data manipulation, analysis, and archiving.
3. Commands for generating graphical plots of data and special graphics files for archival, hard copy, and exporting to commercial graphics and analysis packages.

#### 4.2.7.1 Types of Plots Available

A SENTRAN7 plot of results from a LOWTRAN7 calculation consists of a dependent parameter (such as transmittance, radiance, differential transmittance, etc.) in terms of one or two independent parameters. The dependent parameter is always the z axis. Table 13 lists the type of plots available from the G&A Module and the specific choices for the z axis. As will be discussed further in Section 4.2.7.4, SENTRAN7 imposes restrictions on the choices of the x and y axes among the two independent variables. For this reason, the user is urged to note that SENTRAN7's G&A Module is intended to represent a tool for use in analyzing results from a LOWTRAN7 simulation, but is not intended as the only tool to use.

#### 4.2.7.2 Invoking the Graph and Analyze Module

The Graph and Analyze Module extracts its data from LOWTRAN7's output files based on the current information specified in the Edit Module. Therefore, users are encouraged to use the Graph and Analyze Module immediately after running LOWTRAN7, and avoid changing any parameters in the Edit Module.

To enter the G&A Module, the user types '6' or 'graph', or any sub-string of the word 'graph', such as 'g', at the Main Menu prompt. The initial G&A screen will then appear. An example of this screen is shown in Figure 12.

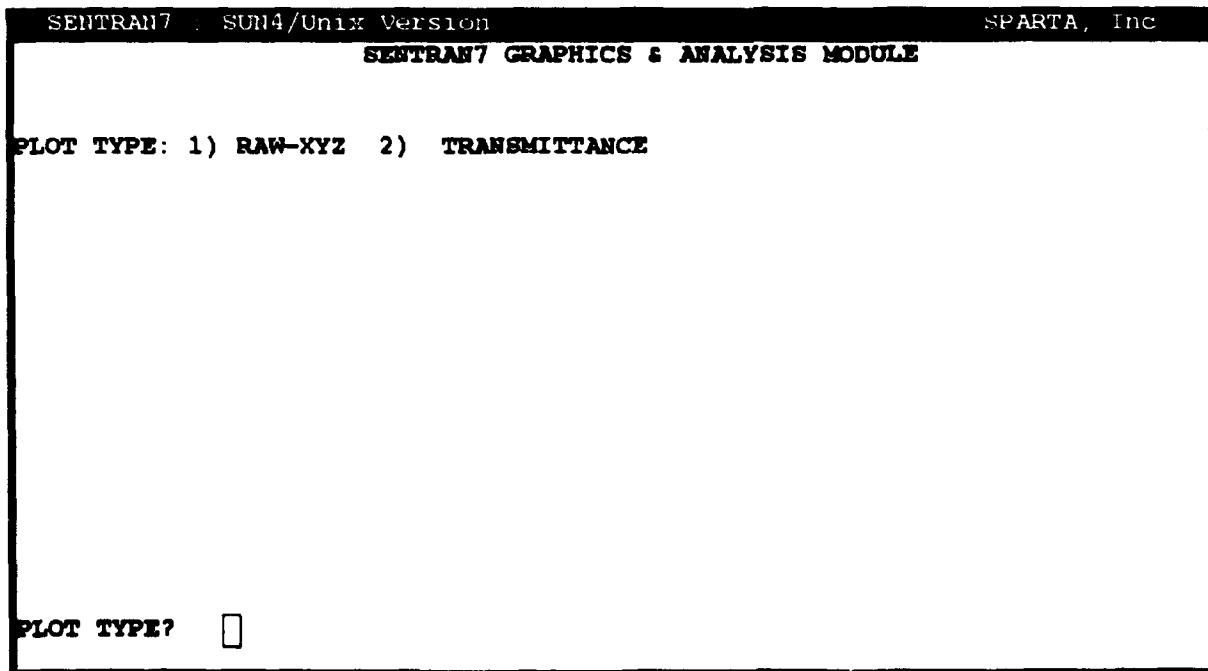

Figure 12. Example of an Initial Screen in the Graph and Analyze Module

Table 13. Type of Plots Available in the SENTRAN7 Graph and Analyze Module

| PLOT TYPE                         | z AXIS PARAMETER CHOICES   |
|-----------------------------------|--|
| <b>Raw <math>x, y, z</math></b>   | None needed  |
| <b>Transmittance</b>              | Total Transmittance<br>Log of Total Transmittance<br>Uniform Mixed Gases<br>Trace Gases<br>Molecular Scattering<br>H <sub>2</sub> O<br>H <sub>2</sub> O Continuum<br>Ozone (O <sub>3</sub> )<br>N <sub>2</sub> Continuum<br>Aerosol and Hydrometeor<br>CO <sub>2</sub><br>CO<br>CH <sub>4</sub><br>N <sub>2</sub> O<br>O <sub>2</sub><br>NH <sub>3</sub><br>NO<br>NO <sub>2</sub><br>SO <sub>2</sub><br>HNO <sub>3</sub><br>Aerosol and Hydrometeor Absorption |
| <b>Atmospheric Radiance</b>       | Total Transmittance<br>Radiance<br>Log of Total Transmittance  |
| <b>Differential Transmittance</b> | DTAU<br>DTAU / Layer Thickness   |
| <b>Black Body Function</b>        | DTAU * Black Body Function<br>(DTAU * Black Body Function) /<br>Layer Thickness  |
| <b>Fluxes/Irradiance</b>          | Upward Total FLUX<br>Upward Solar FLUX<br>Downward Total FLUX<br>Downward Solar FLUX<br>Direct Solar Irradiance  |
| <b>Solar/Lunar Radiance</b>       | Total Transmittance<br>Radiance<br>Path Scattered<br>Single Scattered<br>Total Ground Reflectance<br>Direct Reflected<br>Total Radiance<br>Log of Total Transmittance  |
| <b>Direct Solar Radiance</b>      | Total Transmittance<br>Transmitted Solar<br>Incident Solar<br>Log of Total Transmittance   |

### 4.2.7.3 Specifying the Plotting Parameters

Upon entry into the G&A Module, the user will be prompted for a number of options regarding the sources of data to be plotted. These selections control how SENTRAN7 extracts data from various sources, although from the user's point of view the choices will appear to relate to the selection of two independent axes ( $x$  and  $y$ ) and one dependent axis ( $z$ ).

For all plot types, the user is prompted for the output file in which to find the data. For all cases except when plotting a raw  $x, y, z$  data file, SENTRAN7 will provide a default file name (*TAPE7.OUT* or *TAPE8.OUT*). The default file name given corresponds to the last LOWTRAN7 or MODTRAN output file produced. Whether the default file name is *TAPE7.OUT* or *TAPE8.OUT* will depend on the  $z$  axis parameter chosen to plot. To accept the default file name, should simply hit RETURN. To plot data from a previous LOWTRAN7 or MODTRAN run, enter the output file name and then hit RETURN.

### 4.2.7.4 Restrictions Imposed by the Graph and Analyze Module

When selecting the plotting parameters, the Graph and Analyze Module of SENTRAN7 imposes some restrictions on the choices available. For example, if the user selects the differential transmittance plot type, DTAU, the G&A Module **automatically** sets the  $x$  axis to atmospheric layer number and the  $y$  axis to wavenumber or wavelength. These axes choices are "hardwired" into the code and **cannot** be changed by the user. Other graphing restrictions are imposed based on the number of parameters being perturbed and the choice of MESH or NOMESH options. Appendix D contains a more detailed description of the logic flow of the plotting options and how and when these restrictions are established.

It is recognized that these restrictions may be frustrating to the user and may represent choices the user did not want to make. These restrictions were established in the original version of SENTRAN developed for LOWTRAN6 and resources were not available to change them under this effort. It is hoped that in future revisions to SENTRAN7 these restrictions can be lessened or eliminated.

### 4.2.7.5 Commands Available With the Graph and Analyze Module

Once the user has responded to the questions regarding data sources, the G&A Module enters a special loop that interprets single line commands and immediately executes them in order to manipulate and plot the data set. Commands are always issued from a text screen known as the command screen, while plots are displayed on a special graphics screen. Figure 13 shows a typical G&A command screen and Figure 14 shows a representative 3-D plot. Note that commands need not be typed in their entirety, provided the shortened command matches the first several letters of the desired command and does not match any other command. The commands in

the G&A Module can be divided into three main groups: 1) numerical commands, 2) plotting commands, and 3) I/O and control commands.

```
SENTRAN7      SUN4 Unix Version      SPARTA, Inc
SENTRAN7 GRAPHICS & ANALYSIS MODULE

PLOT TYPE: TRANSMITTANCE      FILE NAME : TAPE7.OUT
X-AXIS   : RANGE
Y-AXIS   : H1
WAVENUM. : 1300
UNITS OF : CM-1
Z-AXIS   : TOTAL TRANSMITTANCE

COMMAND ? 
```

Figure 13. An Example of a Command Screen from the SENTRAN7 Graph and Analyze Module

The numerical commands perform common arithmetic manipulations on the data set. Table 14 lists all of the numerical commands that enable the user to analyze and manipulate the data. These commands permit numerical differentiation and common numerical conversions to be carried out. When a numerical operation or conversion is applied to an axis, the axis' label is modified accordingly. For example, if the z axis label is "TRANSMITTANCE", and the user performs a log conversion on the z axis, then the z axis label will be "LOG TRANSMITTANCE". This change is reflected both on the plots and on the command screen.

The plotting commands provide the user with a means to control certain aspects of the graphical presentation of the data set. Table 15 lists the plotting commands available in the G&A Module of SENTRAN7. The main plotting command is the PLOT command. The PLOT command initiates plotting of the data set. The user must provide an argument consisting of a file name to which graphics data will be written and/or the reserved argument 'VT240', which will cause the plot to be sent to the terminal screen. The plot file is automatically given a .TEK extension if no

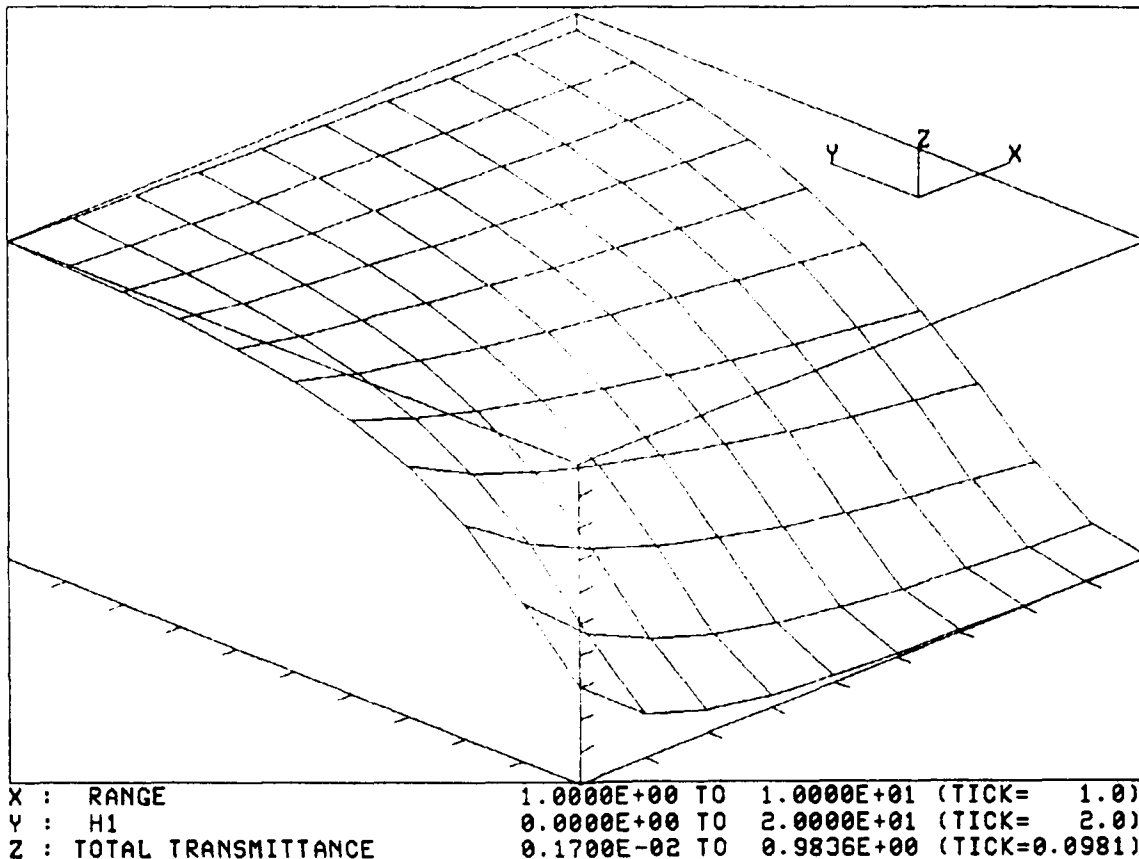

Figure 14. An Example of a 3-D Plot from the SENTRAN7 Graph and Analyze Module

extension is supplied by the user. Note that the user can specify both a file name and the reserved argument 'VT240' in order to have the graph written to both a file and the screen. If the graph is a 3-D plot, the user will also be prompted for rotation angles for the axes. The user may enter these values in free format or press the RETURN key to accept the values which are currently displayed in the field. The first angle is a counterclockwise rotation about the original z axis, while the second angle is a counterclockwise rotation about the x axis (*i.e.*, tilt out of the screen). (Note that these rotation angles are often adjusted slightly by the G&A Module before plotting.) After entering these parameters, the G&A Module will plot the data, either to the file specified, the screen or both. If the plot is to the screen, hitting RETURN will return the user to the command screen.

The other commands shown in Table 15 provide a means for controlling the graphical presentation of the data. These commands include the TITLE command for placing a title at the top of the graph, and labeling commands for the x, y and z axes: XLABEL, YLABEL and ZLABEL, respectively. With all four of these

Table 14. List of Numerical Commands in the SENTRAN7 Graph and Analyze Module

| COMMAND        | ARGUMENTS | DESCRIPTION  |
|----------------|-----------|--|
| <b>A2T</b>     | NONE      | Optical Depth to Transmittance Transformation<br>Transform $z$ axis according to $z=\exp(-z)$  |
| <b>DX</b>      | NONE      | Compute partial derivative of the data set<br>with respect to the $x$ axis                     |
| <b>DY</b>      | NONE      | Compute partial derivative of the data set<br>with respect to the $y$ axis                     |
| <b>DDX</b>     | NONE      | Compute second partial derivative of the data set<br>with respect to the $x$ axis              |
| <b>DDY</b>     | NONE      | Compute second partial derivative of the data set<br>with respect to the $y$ axis              |
| <b>DYDX</b>    | NONE      | Compute cross derivative of the data set<br>with respect to the $y$ axis and then the $x$ axis |
| <b>DXDY</b>    | NONE      | Compute cross derivative of the data set<br>with respect to the $x$ axis and then the $y$ axis |
| <b>LOG</b>     | [X][Y][Z] | Transform all coordinates of the named axis<br>to their log values (Example: 'log x')          |
| <b>MAXIMUM</b> | NONE      | Write the maximal $z$ values on the screen along<br>with their $x,y$ coordinates               |
| <b>MEAN</b>    | NONE      | Compute and displays the mean $z$ axis value   |
| <b>MINIMUM</b> | NONE      | Write the minimal $z$ values on the screen along<br>with their $x,y$ coordinates               |
| <b>NOSORT</b>  | [X][Y]    | Suppress SENTRAN's tendency to sort data into<br>increasing order (Example: 'nosort x')        |
| <b>SWAP</b>    | NONE      | Swap the $x$ and $y$ axes  |
| <b>T2A</b>     | NONE      | Transmittance to Optical Depth Transformation<br>Transform $z$ axis according to $z=\log(1/z)$ |

commands, the text entered by the user following the command is treated as the title or axis label, respectively.

Table 16 lists the I/O and control commands of the G&A Module. There are currently five general control commands: WRITE, COSMETIC, NEW, EXIT, HELP and REFRESH.

In order to conveniently store the  $x$ ,  $y$ , and  $z$  data currently being plotted, SENTRAN7 provides a WRITE command in the G&A Module for writing the

Table 15. List of Plotting Commands in the SENTRAN7 Graph and Analyze Module

| COMMAND | ARGUMENTS          | DESCRIPTION   |
|---------|--------------------|---|
| PLOT    | [file name][VT240] | Plot the data set to the specified file name (*.TEK) or to the screen [VT240 argument] (NOTE: Both arguments may be specified and the program will plot the data to the file and to the screen) |
| TITLE   | [plot title]       | Treat all following text as title for next plot, and center this text at the top of the plot  |
| XLABEL  | [x axis Label]     | Treat all following text as the x axis label (up to 30 characters)  |
| YLABEL  | [y axis Label]     | Treat all following text as the y axis label (up to 30 characters)  |
| ZLABEL  | [z axis Label]     | Treat all following text as the z axis label (up to 30 characters)  |

Table 16. List of I/O and Control Commands in the SENTRAN7 Graph and Analyze Module

| COMMAND  | ARGUMENTS           | DESCRIPTION   |
|----------|---------------------|---|
| WRITE    | [x, y, z file name] | Write the current data set to the named file as raw x, y, z data (default extension is .3D)   |
| COSMETIC | [file name]         | Screendump of current G&A command screen to the named file  |
| NEW      | NONE                | Restart the G&A Module  |
| EXIT     | NONE                | Exit the G&A Module, return to Main Menu  |
| HELP     | [command name]      | Accesses the G&A on-line help utility. If a valid G&A command is supplied as an argument, then help on the selected command is provided. If no argument is supplied, then a special introductory HELP screen is presented, listing all of the G&A commands. |
| REFRESH  | NONE                | Redraw the G&A command screen   |

data to a file. The user simply types '**write filename**' at the command line prompt and the current  $x$ ,  $y$ , and  $z$  data are written in three columns to that file. No header information is stored in the file. The filename is automatically given a *.3D* extension if none is specified. For example, if the user enters '**write test**', the data are written to the file *TEST.3D*. If the user enters '**write test.dat**', the data are stored to the file *TEST.DAT*. These files can be used to save specific results the user is interested in, rather than saving the sometimes large *tape7* and *tape8* files that LOWTRAN7 and MODTRAN can produce. They can easily be plotted again at a later time by choosing the raw  $x$ ,  $y$ ,  $z$  plot type in the G&A Module. In addition, these data files can easily be used by other commercial graphics programs to create more detailed plots.

The COSMETIC command of the G&A Module provides a quick method for storing what data has been plotted or written to a raw  $x$ ,  $y$ ,  $z$  file. This command, writes a screen dump of the G&A command screen to a file specified by the user. A default extension of *.COS* is attached to the filename if none is specified.

In order to restore altered data or to select an alternative data set, the user must restart the G&A Module by using the NEW command. This places the user at the initial G&A menu for choosing the plot type. The user will need to specify the plotting parameters again before resuming command mode. The NEW command must also be used to "refresh" the data set if, for example, the user wants to look at the derivative of the original data, after having already taken the LOG of the data.

If for some reason the G&A command screen becomes corrupted (by a system message from another user, for example), the user can enter the REFRESH command to restore the G&A screen. This command simply redraws the command screen.

The HELP command accesses the G&A on-line help utility. This command is especially useful for recalling what commands are available within the G&A Module of SENTRAN7, and also what each of these commands do. If the user enters '**help**' with no argument supplied, a special introductory help screen is presented, listing all the available G&A commands. The user can also obtain specific information about each of these commands by entering '**help command**', where *command* is the command name the user needs a description of. For example, to obtain information about the PLOT command, the user enters '**help plot**' at the command line. A help screen containing a description of the PLOT command will appear as shown in Figure 15. The user hits RETURN or ENTER to return to the G&A module command screen.

```

SENTRAN7 : SUN4/Unix Version          SPARTA, Inc
                SENTRAN7 GRAPHICS & ANALYSIS MODULE

PLOT TYPE: TRANSMITTANCE          FILE NAME : TAPE7.OUT
X-AXIS   : WAVENUMBER
Y-AXIS   : RANGE

SENTRAN7 : SUN4/Unix Version          SPARTA, Inc
                SENTRAN HELP UTILITY

UNITE
Z-AXI
COMMJ

The PLOT command initiates the plotting sequence. PLOT requires
at least one argument. The argument will generally be a .TEK
output file. However, the name VT240 is a reserved argument
which will send graphical output to the terminal. An output
file name and the VT240 argument can both be provided, causing
output to be directed to the screen and the .TEK file simultaneously.

EXAMPLE :

PLOT TEST VT240

Will form a graphics file TEST.TEK and display the plot on the user's
terminal. After the PLOT command is entered, the user is prompted for
rotation angles. PLOT then proceeds and returns to COMMAND input when
finished.

                HIT <RETURN> TO CONTINUE

```

Figure 15. An Example of an On-Line Help Screen Within Graph and Analyze Module of SENTRAN7. (Note that the help screen does not appear as a partial overlay during execution as shown in this figure, but rather covers the entire screen.)

#### 4.2.8 Plotting Trace Gas Input Profiles

A new feature of SENTRAN7 is the ability to plot trace gas profiles and their perturbations. This option has been implemented in a two-step process. The user first stores the trace gas profile, and its perturbation values, if any, by typing the command 'write' when editing the particular molecular species on the LOWTRAN input card Card 2C. Second, the user plots these data from within the G&A Module of SENTRAN7 by choosing the option to plot a raw  $x, y, z$  data file and entering the filename created within the Edit Module.

When the user types 'write' while editing Card 2C, the input profile data for the molecular species the user is currently editing is written to a raw data file. If the molecular species has been perturbed by the user, the perturbation values

are also written to the data file. The data files are automatically named by the program with the first part of the filename being set to the parameter name (*i.e.*, P, T, O<sub>3</sub>, etc.), with the default extension *.3D* added. The data file consists of five columns. The first column consists of the data values for the unperturbed molecular species. The second column, which represents the y axis data, will always be zero because this is a 2D plot. The third column contains the altitude data to be plotted on the z axis. The fourth and fifth columns contain the minus and plus percent perturbations, respectively, of the original molecular species data values. If no percent perturbation was entered by the user, these columns are set to -999.0.

At this point, it must be mentioned that the **write** command creates a *.3D* data file based on numerical values in the specified *.PRO* file, but it does not consider the values of JCHAR. This is an important footnote to remember because LOWTRAN7 uses model atmosphere amounts for layers where JCHAR is set to 1-6, even if numerical values are specified. For these scenarios, the trace gas profiles plotted by SENTRAN7 do not represent the actual profiles used by LOWTRAN7. Future versions of SENTRAN7 will hopefully address this dilemma.

Figures 16-20 provide the user with a specific example of how to perturb a parameter on the LOWTRAN input Card 2C and write the input profile of this parameter, along with its perturbation values, to a file. This example perturbs the O<sub>3</sub> parameter on Card 2C by 20% and writes the input profile to the default file, *O3.3D*. In this example, it is assumed that the user is editing the LOWTRAN input Card 2C and presses RETURN until the cursor is positioned on the line containing the O<sub>3</sub> parameter. The user then enters '**%20**' for the perturbation value for the O<sub>3</sub> parameter, as shown in Figure 16, and hits RETURN. The cursor is now located on the N<sub>2</sub>O parameter on Card 2C. To move the cursor back to the O<sub>3</sub> parameter, the user enters the '**up**' command, as shown in Figure 17. The '**up**' command moves the cursor back to the line containing the O<sub>3</sub> parameter. The user then types in '**write**' while on the line containing the O<sub>3</sub> parameter in order to write the O<sub>3</sub> input profile and its perturbation values to the file *O3.3D*. This is shown in Figure 18. Once the file has been written, the name of the file is displayed in the lower right hand corner of the screen, as shown in Figure 19. The contents of the file *O3.3D* are shown in Figure 20. Recall that the first column is the original O<sub>3</sub> input profile and the third column is the altitude. The fourth column is a -20% perturbation and the fifth column is a +20% perturbation of the first column.

Note that the above example was a specific example involving the O<sub>3</sub> parameter on the LOWTRAN Card 2C. The user can perturb any of the parameters on Card 2C and write that parameter's input profile and perturbation values to a file, using a similar method. Also note that it is not necessary to perturb the input profile before writing that profile to an output file. If the user wishes to write the input profile of a parameter on Card 2C to a file, without perturbing that parameter, the user

```

SENTRAN7 : SUN4/Unix Version                               SPARTA, Inc.
SENTRAN7 EDITING UTILITY

EDITING CARD 2C

FOLLOWING PARAMS ACCEPT ONLY % PERTURBATIONS

ZMDL                N2O                AHAZE
P...                CO                 EQLWCZ
T...                CH4                RRATZ
H2O                 O2                 IHA1
CO2                 NO                 CLD1
O3                  %20       SO2                IVUL1
                   NO2                ISEAL
                   NH3                ICHR1
                   HNO3

```

Figure 16. An Example of the Command Used to Perturb the O<sub>3</sub> Input Profile on the LOWTRAN Input Card 2C by 20%

need simply enter the 'write' command when the cursor is located at the desired parameter, without entering a percent perturbation.

Once the input profiles on Card 2C have been written to an output file, they can be plotted within the G&A Module by choosing the raw *x, y, z* plot type and entering the output filename (\*.3D) saved within the Edit Module. The graphical output of the O<sub>3</sub> input profile saved in the example above, is shown in Figure 21. The O<sub>3</sub> input profile is plotted along with ±20% perturbations. This plot is created by choosing the raw *x, y, z* plot type within the G&A Module and entering the filename *O3.3D*. The user must label the axes by using the XLABEL and ZLABEL commands before plotting the data. The LOG command within the G&A Module can also be used on the input profile plots. However, the derivative commands are not available when plotting trace gas input profiles.

#### 4.2.9 Miscellaneous

There are three simple commands accessible from the Main Menu, which are not displayed as Main Menu choices. These are the LOG, NOPROMPT, and ZAP commands.

The LOG command turns on SENTRAN7's logging capability. When this command is entered, SENTRAN7 will proceed to write all user input to a file named *SEN.LOG*. SENTRAN7 automatically adds comments to this file that help the user to determine the logical flow taken through SENTRAN7, aiding the user in interactive development and the debugging of files for batch made submission.

```

SENTRAM7  SUN4/Unix Version  SPARTA  Inc
SENTRAM7 EDITING UTILITY
EDITING CARD 2C
FOLLOWING PARAMS ACCEPT ONLY & PERTURBATIONS
ZMDL      N20      up
P...      CO
T...      CH4
H2O       O2
CO2       NO
O3        420     SO2
           NO2
           NH3
           HNO3
           AHAZE
           EQLWCZ
           RRATZ
           IHA1
           CLD1
           IVUL1
           ISEAL
           ICHRI

```

Figure 17. Example of the Command to Move the Cursor Up One Line to the O<sub>3</sub> Parameter on the LOWTRAN Input Card 2C Sequence

```

SENTRAM7  SUN4/Unix Version  SPARTA  Inc
SENTRAM7 EDITING UTILITY
EDITING CARD 2C
FOLLOWING PARAMS ACCEPT ONLY & PERTURBATIONS
ZMDL      N20      AHAZE
P...      CO      EQLWCZ
T...      CH4     RRATZ
H2O       O2      IHA1
CO2       NO      CLD1
O3        write   SO2
           IVUL1
           NO2     ISEAL
           NH3     ICHRI
           HNO3

```

Figure 18. Example of the Command to Write the O<sub>3</sub> Input Profile Specified by the LOWTRAN Input Card 2C to a Data File

```

SENTRAN7   SUN4/Unix Version   SPARTA, INC.
          SENTRAN7 EDITING UTILITY
          EDITING CARD 2C
          FOLLOWING PARAMS ACCEPT ONLY & PERTURBATIONS

ZMDL      N2O      AHAZE
P...      CO       EQLWCZ
T...      CH4      RRATZ
H2O       O2       IHA1
CO2       NO       CLD1
O3        SO2      IVOL1
           NO2      ISEAL
           NH3      ICHR1
           HNO3

          .3D FILE : O3.3D

```

Figure 19. Example of the Screen Displayed After the Perturbed O<sub>3</sub> Input Profile Has Been Written to a File

The user may replace these automatic comments with comments of his or her own when entering commands into SENTRAN7. Comments consist of all text within the input string following an apostrophe. For example, in the string, **edit 'invoke editor function**, "invoke editor function" is a comment and will be ignored by the program. SENTRAN7 will then display the word "LOG" in the extreme upper left of the screen when the LOG feature is active.

The NOPROMPT command suppresses all writing to the screen. This feature is useful for batch submissions since screen output is unnecessary in such situations. NOPROMPT also functions as a toggle. Therefore, if screen output is inadvertently disabled, it may be re-enabled by typing **'noprompt'** a second time.

The ZAP command resets all LOWTRAN7 variables to their default values and eliminates all perturbation directives. (The default values are "hardwired" into the SENTRAN7 code and cannot be changed.) The ZAP command is useful when the user wishes to make extensive revisions to LOWTRAN7 input cards; revisions so extensive that starting from the default values of the LOWTRAN7 variables, with no perturbations, is simpler than editing all of the necessary variables and removing perturbation commands that have already been entered by the user.

|         |         |           |         |          |
|---------|---------|-----------|---------|----------|
| 0.02869 | 0.00000 | 0.00000   | 0.02295 | 0.03443  |
| 0.03150 | 0.00000 | 1.00000   | 0.02520 | 0.03780  |
| 0.03342 | 0.00000 | 2.00000   | 0.02674 | 0.04010  |
| 0.03504 | 0.00000 | 3.00000   | 0.02803 | 0.04205  |
| 0.03561 | 0.00000 | 4.00000   | 0.02849 | 0.04273  |
| 0.03767 | 0.00000 | 5.00000   | 0.03014 | 0.04520  |
| 0.03989 | 0.00000 | 6.00000   | 0.03191 | 0.04787  |
| 0.04223 | 0.00000 | 7.00000   | 0.03378 | 0.05068  |
| 0.04471 | 0.00000 | 8.00000   | 0.03577 | 0.05365  |
| 0.05000 | 0.00000 | 9.00000   | 0.04000 | 0.06000  |
| 0.05595 | 0.00000 | 10.00000  | 0.04476 | 0.06714  |
| 0.06613 | 0.00000 | 11.00000  | 0.05290 | 0.07936  |
| 0.07815 | 0.00000 | 12.00000  | 0.06252 | 0.09378  |
| 0.09289 | 0.00000 | 13.00000  | 0.07431 | 0.11147  |
| 0.10500 | 0.00000 | 14.00000  | 0.08400 | 0.12600  |
| 0.12560 | 0.00000 | 15.00000  | 0.10048 | 0.15072  |
| 0.14440 | 0.00000 | 16.00000  | 0.11552 | 0.17328  |
| 0.25000 | 0.00000 | 17.00000  | 0.20000 | 0.30000  |
| 0.50000 | 0.00000 | 18.00000  | 0.40000 | 0.60000  |
| 0.95000 | 0.00000 | 19.00000  | 0.76000 | 1.14000  |
| 1.40000 | 0.00000 | 20.00000  | 1.12000 | 1.68000  |
| 1.80000 | 0.00000 | 21.00000  | 1.44000 | 2.16000  |
| 2.40000 | 0.00000 | 22.00000  | 1.92000 | 2.88000  |
| 3.40000 | 0.00000 | 23.00000  | 2.72000 | 4.08000  |
| 4.30000 | 0.00000 | 24.00000  | 3.44000 | 5.16000  |
| 5.40000 | 0.00000 | 25.00000  | 4.32000 | 6.48000  |
| 9.30000 | 0.00000 | 30.00000  | 7.44000 | 11.16000 |
| 9.70000 | 0.00000 | 35.00000  | 7.76000 | 11.64000 |
| 7.50000 | 0.00000 | 40.00000  | 6.00000 | 9.00000  |
| 4.50000 | 0.00000 | 45.00000  | 3.60000 | 5.40000  |
| 2.80000 | 0.00000 | 50.00000  | 2.24000 | 3.36000  |
| 0.30000 | 0.00000 | 70.00000  | 0.24000 | 0.36000  |
| 0.40000 | 0.00000 | 100.00000 | 0.32000 | 0.48000  |

Figure 20. Sample of a Trace Gas Input Profile Data File (O3.3D) as Created Using a 20% Perturbation

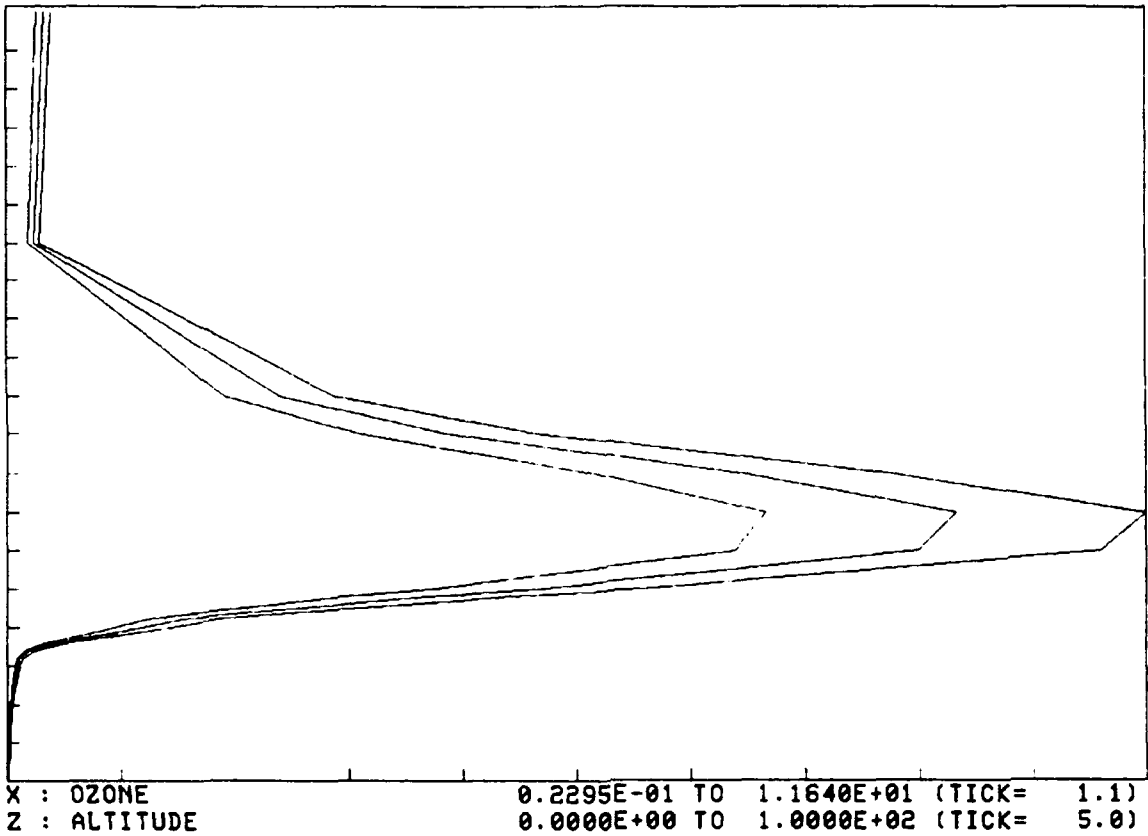

Figure 21. An Example of a 2-D Plot of an O<sub>3</sub> Input Profile with ± 20% Perturbations Assumed

## 5 SENTRAN7 TUTORIAL

While the previous chapters provided a fairly general description of SENTRAN7 from a functional point of view, it does little in the way of teaching the user how to actually use SENTRAN7. This chapter will guide the user through a series of brief exercises which should make the user reasonably comfortable with using SENTRAN7. It is encouraged that the user actually use the program while proceeding through these tutorials.

### 5.1 Basic Concepts of the User Interface

One of the chief features of SENTRAN7 is its flexible user interface, which permits users to perform the exact same task in a number of different ways. This allows the program to accommodate differences in personal preference with respect to data entry and makes it more comfortable for users who have differing levels of skill in using the program. For example, novice users can proceed in a step-by-step manner, providing simple responses to a series of prompts, while advanced users may prefer to type in complete command strings, bypassing the majority of input prompts. This command parsing feature can dramatically reduce the time required to perform routine tasks. The following tutorials will demonstrate both step-by-step and command driven syntax. Again, we stress that it is worth the time investment required to use the software while learning the command driven syntax.

### 5.2 Conventions Used in the Tutorials

As the user proceeds through the following tutorials, please keep the following conventions in mind:

- The text which must be entered will appear in '**boldface**', and single quotes. Note also that when running SENTRAN7 you may use either lower or upper case.
- You must press the RETURN (or ENTER) key after every command.
- Often, the only input required will be the pressing of the RETURN key (*i.e.*, when accepting a default, or acknowledging an error message). Therefore RETURN means "press the return or enter key". Note that the term "RETURN key" is equivalent to "ENTER key" in these tutorials.

## 5.3 SENTRAN7 Tutorial #1

### 5.3.1 Getting Started

Begin by executing the SENTRAN7 executable file on your system. The file *LAST.MTH* is loaded into SENTRAN7 immediately upon execution, provided that it exists, and provides a default methodology. A methodology file, such as *LAST.MTH*, contains images of LOWTRAN7 or MODTRAN input parameters (the standard input "cards") and control parameters for their perturbation. (When running SENTRAN7, the most recent methodology file generated is always copied into a special file named *LAST.MTH*, which as mentioned above is used by SENTRAN7 at start-up.) When SENTRAN7 is executed for the first time, a *LAST.MTH* methodology file may not yet exist. If this is the case the initial screen will look like Figure 22. The program displays an error message in reading the last methodology file. Don't panic! The program will continue with the default parameters set within the software code. Once you hit RETURN, the SENTRAN7 Main Menu will appear, as shown in Figure 23.

### 5.3.2 Using the Load and Save Module

The Load and Save Module permits you to retrieve and store LOWTRAN7 input parameters and directives for parameter variation. In the following tutorial, we will load one of the methodology files that is supplied with the distribution tape named *DEFAULT.MTH*, and save it under the name *FIRST.MTH*, using both step-by-step and command driven techniques.

#### Step 1:

Type '1' at the Main Menu shown in Figure 23 in order to load a methodology file.

#### Step 2:

SENRAN7 will prompt you to specify if you want to load or save a methodology file, as shown in Figure 24. In response to this prompt, enter 'load'.

The program will then display a list of all the files in the current directory that have the extension *.MTH*, which is the default extension for methodology files, and will prompt you for the file name to load. An example of the displayed screen is shown in Figure 25. (Note that your screen may not look exactly like this example because you will not have the same methodology files in your current directory.)

#### Step 3:

In response to the prompt for a methodology file name, enter 'default'. SENTRAN7 will load *DEFAULT.MTH* and return to the Main Menu.

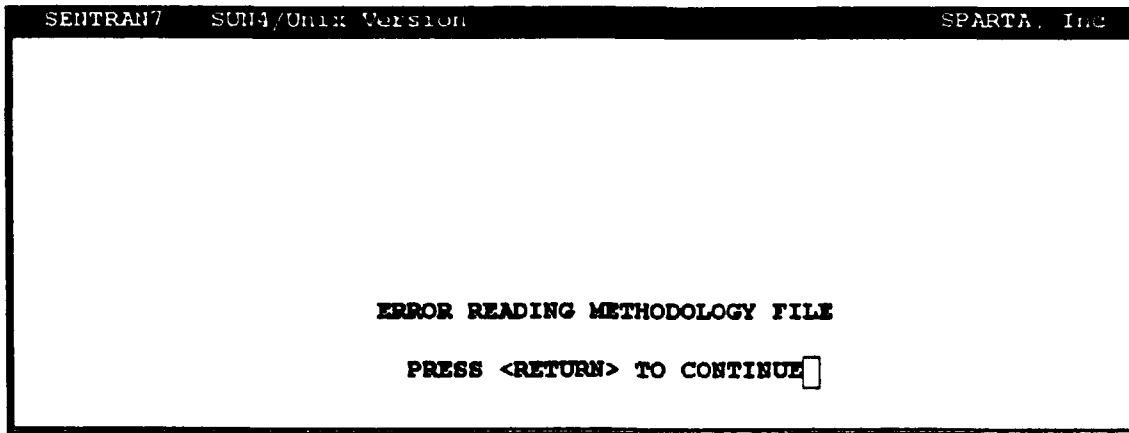

Figure 22. SENTRAN7 Screen Displayed When the *LAST.MTH* Methodology File is not Found to Exist

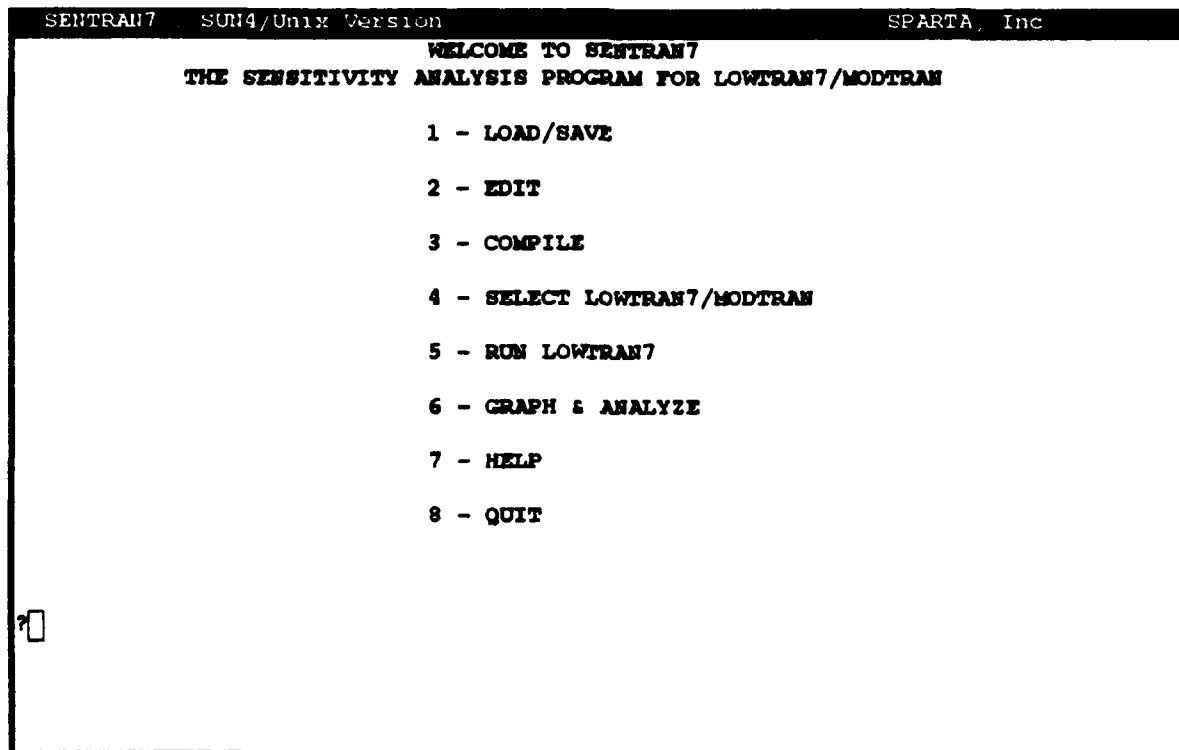

Figure 23. The Main Menu of SENTRAN7

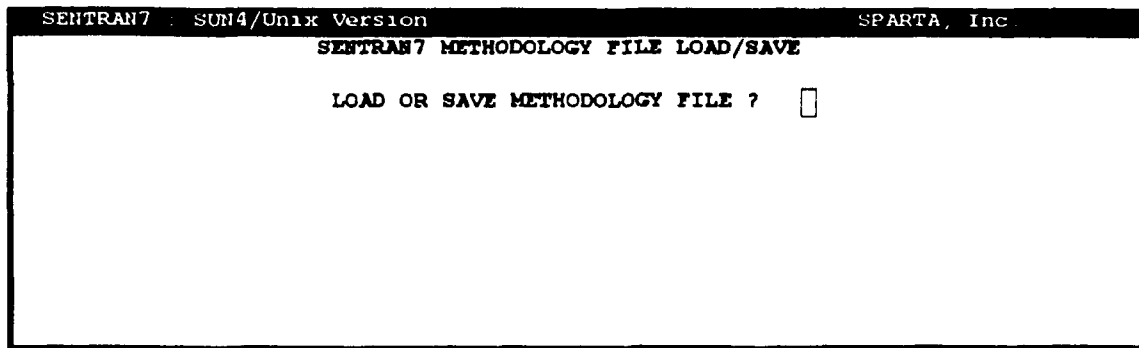

Figure 24. Screen Prompt for Specifying Use of the Load or Save Options

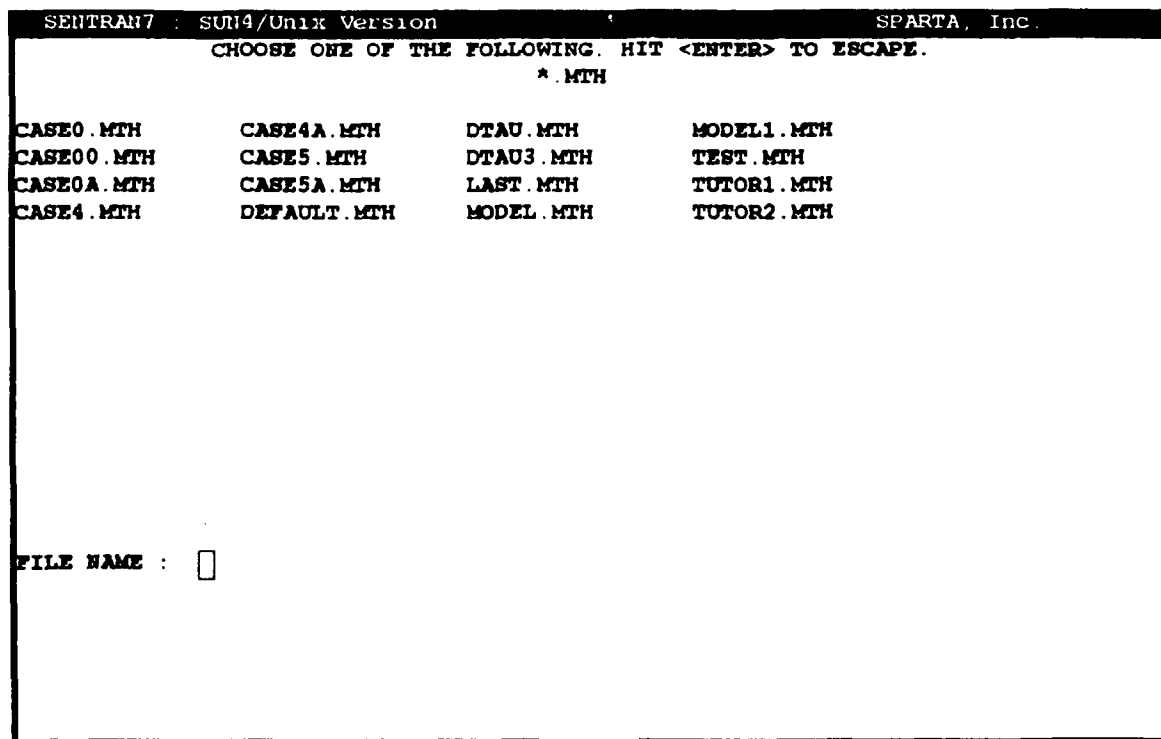

Figure 25. Example of the SENTRAN7 Screen Listing the Available Methodology Files to Load Into SENTRAN7

**Step 4:**

Now, repeat Step 1 and type 'load default' at Step 2. Note that this accomplishes the same task as Steps 1, 2 and 3 in one less step.

**Step 5:**

At the Main Menu type 'load default'. Note that we have accomplished the task of loading *DEFAULT.MTH* in a single step!

Now that we have loaded *DEFAULT.MTH*, its contents are stored in the appropriate parameters in the Edit Module. The following steps will save the values of the parameters in the Edit Module, to a file named *FIRST.MTH*.

**Step 6:**

Enter '1' at the Main Menu prompt to again invoke the Load/Save Module.

**Step 7:**

In response to the prompt for "LOAD OR SAVE METHODOLOGY FILE", as shown in Figure 24, type 'save'. SENTRAN7 will prompt you for the name of the methodology file to create.

**Step 8:**

In response to the prompt for a methodology file name, type 'first'. SENTRAN7 will then create a new methodology file named *FIRST.MTH* which is identical to *DEFAULT.MTH*. You may wish to verify this fact.

**Step 9:**

We can reduce the number of steps required to save *FIRST.MTH* by performing Step 6 and typing 'save first' at Step 7.

**Step 10:**

We may reduce the number of steps further by entering 'save first' at the Main Menu prompt. This will accomplish the same task as Steps 6, 7 and 8 in a single step.

Since we have just generated a file named *FIRST.MTH*, the values stored in this methodology file are still set to the parameters in the Edit Module. If you have not performed the above steps, please do so now, since it is important that the screens which SENTRAN7 presents are identical to those in this tutorial. Our next goal is to modify *FIRST.MTH* in order to generate the following test case:

*Transmittance for horizontal paths with various optical ranges (1 to 10 km) at several altitudes (0 to 20 km) for a selected wavenumber of 1300 cm<sup>-1</sup> with MODEL=6 and IHAZE=1*

We will accomplish this task by first editing the necessary input cards as described in the following section.

### 5.3.3 Using the Edit Module

Before we begin, it is important to remind you of the basic methods for moving around in the Edit Module of SENTRAN7 and what to do if you make a mistake. If you enter an incorrect value at a line or inadvertently skip past a line, don't panic. You can move up and down within the card image by using the 'up' and 'dn' commands. For example, if you need to move back to a previous parameter on a card, type 'up' and the number of lines to move back, and press RETURN. The cursor will move back to that parameter, provided that line of the input card is editable. Use these commands then to move the cursor back to the line which is in error and type over your mistake. Note that if the last parameter edited was two up from the current parameter you must type 'up 2' to move backward. (See Section 4.2.3 for greater detail on the Edit Module's capabilities.)

Complete the following steps in order to generate the test case described earlier. You will be providing the values for the standard LOWTRAN7 input parameters. If you are unfamiliar with their meaning, please refer to the LOWTRAN7 manual<sup>1</sup>.

#### Step 1:

Type either '2' or 'edit' or some substring of edit (such as 'ed') at the Main Menu prompt (see Figure 23) in order to execute the Edit Module of SENTRAN7. The screen for editing Card 1 will appear as shown in Figure 26.

#### Step 2:

The cursor will presently be located on the line MODEL. Note that at any time, the user can type 'help' to display a brief description of the current parameter being entered. For example, type 'help' now, as shown in Figure 27.

The program will display information about the MODEL parameter, as shown in Figure 28.

#### Step 3:

Once you have returned from the help utility, the cursor is returned to the line containing the MODEL parameter. In this tutorial, we would like to use the U.S. Standard Atmosphere model, so type '6' and press RETURN. After this value is entered, the line will reformat itself to reflect the change in the value of the MODEL parameter, while the cursor will move to the next line.

#### Step 4:

We have completed our job of editing Card 1, so type 'pd' (for "page down").

```

SENTRAN7 : SUN4/Unix Version                               SPARTA, Inc
SENTRAN7 EDITING UTILITY
EDITING CARD 1

FOLLOWING PARAMS. USE A PERTURBATION LIST (* IMPLIES PERTURBATION RESTRICTIONS)

MODEL *  1
ITYPE * 1
IEMSCT* 2
IMULT * 0
M1 ... 0
M2 ... 0
M3 ... 0
M4 ... 0
M5 ... 0
M6 ... 0
MDEF.. 0
IM ... * 0
NOPRT * 0

FOLLOWING PARAMS. USE A PERTURBATION VALUE
TBOUND 0.000
SALB   0.000

```

Figure 26. Example of the Screen Displayed to Edit Card 1

```

SENTRAN7 : SUN4/Unix Version                               SPARTA, Inc
SENTRAN7 EDITING UTILITY
EDITING CARD 1

FOLLOWING PARAMS. USE A PERTURBATION LIST (* IMPLIES PERTURBATION RESTRICTIONS)

MODEL * help0
ITYPE * 1
IEMSCT* 0
IMULT * 0
M1 ... 0
M2 ... 0
M3 ... 0
M4 ... 0
M5 ... 0
M6 ... 0
MDEF.. 0
IM ... * 1
NOPRT * 0

FOLLOWING PARAMS. USE A PERTURBATION VALUE
TBOUND 0.000
SALB   0.000

```

Figure 27. Example of How to Implement the On-Line Help Utility Within the SENTRAN7 Edit Module

Note that the program asks us if the current card is acceptable. Take this opportunity to check that your Card 1 screen looks like Figure 29.

**Step 5:**

If the card is correct, accept the default (yes) by pressing the RETURN key. Otherwise enter 'n' meaning, "No, the card is not acceptable, I would like to fix it". When you enter 'n', the program returns to the first parameter on the card. Go back to Step 3 of this example and make the appropriate modifications to the card at this point.

**Step 6:**

Completion of Card 1 and acceptance of its contents will move us to the LOW-TRAN7 Card 2 screen, as shown in Figure 30.

**Step 7:**

IHAZE will be the active line. We will use the Rural Extinction model, so enter '1'.

**Step 8:**

We will not need any further changes in Card 2, so type 'pd' to move to the next card image. Once we have accepted the contents of Card 2, the Card 3 screen will appear, as shown in Figure 31.

**Step 9:**

H1 will be the first line in Card 3. We would like to perturb this variable to represent calculations performed at altitudes ranging from 0 to 20 km in steps of 2. To do this, type '0 to 20 step 2'.

**Step 10:**

Note that the program will automatically skip the next two parameters (H2 and ANGLE), since we are computing a horizontal path.

**Step 11:**

RANGE will now be the active variable. Since we would like RANGE to assume all values from 1 to 10 km inclusive, type '1 to 10' (we will use the default step size of 1).

**Step 12:**

Our work on Card 3 is complete and we can proceed to Card 4 by typing 'pd'. Compare your Card 3 image with Figure 32 before proceeding.

**Step 13:**

Once Card 3 has been accepted, Card 4 will appear as shown in Figure 33. Our

```

SENTRAN7      SUN4/Unix Version      SPARTA, Inc
                SENTRAN HELP UTILITY

'MODEL'                                CARD 1

SELECTS ONE OF THE SIX GEOGRAPHICAL-SEASONAL MODEL ATMOSPHERES OR
SPECIFIES THAT USER-DEFINED METEOROLOGICAL DATA ARE TO BE USED:

= 0 METEOROLOGICAL DATA (HORIZONTAL PATH ONLY)
  1 TROPICAL ATMOSPHERE
  2 MIDLATITUDE SUMMER
  3 MIDLATITUDE WINTER
  4 SUBARCTIC SUMMER
  5 SUBARCTIC WINTER
  6 1976 U.S. STANDARD ATMOSPHERE
  7 NEW MODEL ATMOSPHERE (OR RADIOSONDE DATA)

HIT <RETURN> TO CONTINUE

```

Figure 28. Example of the On-Line Help Information in the SENTRAN7 Edit Module

```

SENTRAN7      SUN4/Unix Version      SPARTA, Inc
                SENTRAN7 EDITING UTILITY
                EDITING CARD 1

FOLLOWING PARAMS. USE A PERTURBATION LIST (* IMPLIES PERTURBATION RESTRICTIONS)

MODEL *      6
ITYPE *      1
IEMBCT*      0
IMULT *      0
M1 ...      0
M2 ...      0
M3 ...      0
M4 ...      0
M5 ...      0
M6 ...      0
MDEF ...     0
IM ... *     0
MOPRT *      0

FOLLOWING PARAMS. USE A PERTURBATION VALUE
TBOUND      0.000
SALE        0.000
ALL PARAMETERS FOR CARD 1 O.K. (Y/N) [Y]

```

Figure 29. Example of the Final Screen Displayed After Editing the LOWTRAN7 Input Card 1

```

SENTRAN7 : SUN4/Unix Version          SPARTA, Inc.
                SENTERAN7 EDITING UTILITY
                EDITING CARD 2

FOLLOWING PARAMS. USE A PERTURBATION LIST (* IMPLIES PERTURBATION RESTRICTIONS)

IHAZE *  0
ISEASH 0
IVULCN 0
ICSTL 0
ICLD * 0
IVSA * 0

FOLLOWING PARAMS. USE A PERTURBATION VALUE

VIS ... 0.000
WSS ... 0.000
WHH ... 0.000
RAINRT 0.000
GNDALT 0.000

```

Figure 30. Example of the Initial Screen Displayed to Edit the LOWTRAN7 Card 2

```

SENTRAN7 SUN4/Unix Version          SPARTA, Inc.
                SENTERAN7 EDITING UTILITY
                EDITING CARD 3

FOLLOWING PARAMS. USE A PERTURBATION VALUE

H1 ...  0.000
H2 ... 0.000
ANGLE 0.000
RANGE 1.000
BETA 0.000
RO ... 0.000

FOLLOWING PARAM. USES A PERTURBATION LIST (* IMPLIES PERTURBATION RESTRICTIONS)

LEN * 0

```

Figure 31. Example of the Initial Screen Displayed to Edit the LOWTRAN Input Card 3

```

SENTRAN7  SUN4/Unix Version  SPARTA, Inc
SENTRAN7 EDITING UTILITY

          EDITING CARD 3

FOLLOWING PARAMS. USE A PERTURBATION VALUE

H1 ...      0.000   TO 20 STEP 2
H2 ...      0.000
ANGLE       0.000
RANGE       1.000   TO 10
BETA        0.000
RO ...      0.000

FOLLOWING PARAM. USES A PERTURBATION LIST (* IMPLIES PERTURBATION RESTRICTIONS)
LEN *      0

ALL PARAMETERS FOR CARD 3 O.K. (Y/N) []

```

Figure 32. Example of the Final Screen Displayed After Editing Card 3

```

SENTRAN7  SUN4/Unix Version  SPARTA, Inc
SENTRAN7 EDITING UTILITY

          EDITING CARD 4

THE FOLLOWING PARAMS. CANNOT BE PERTURBED

V1 ....       0.000
V2 ....      20.000
DV ....      5.000
IFWHM      1          (REQUIRED FOR MODTRAN ONLY)

```

Figure 33. Example of the Initial Screen Displayed to Edit Card 4

calculation is concerned only with a single frequency ( $1300\text{ cm}^{-1}$ ). Therefore, we can limit our spectral interval and realize a substantial savings in execution time. V1 will be the current variable, so type '1300'. SENTRAN7 will reformat the line and present V1 in terms of  $\text{cm}^{-1}$  and microns.

**Step 14:**

For V2, enter '1305'. Note that even though we are only concerned with the single frequency,  $1300\text{ cm}^{-1}$ , LOWTRAN7 cannot calculate spectral intervals with a span of 0, therefore we must enter a V2 of  $1305\text{ cm}^{-1}$ .

**Step 15:**

For DV, type '5'.

**Step 16:**

Your card should look like the one shown in Figure 34. If it does, accept its contents by hitting RETURN and accepting the default 'y'. If it does not, take the time now to fix it by entering 'n' and repeating Steps 13 through 15.

**Step 17:**

SENTRAN7 will now ask if you would like to compile the current input cards, as shown in Figure 35. We want to compile the cards, therefore we should press RETURN, accepting the default (yes). Answering 'y' to this prompt has the same effect as choosing the Compile Module from the Main Menu.

**Step 18:**

The program will now prompt you for the name of the input file (\*.INP) to create, as shown in Figure 36. In response to the prompt for an input file name and compile options, type 'test /m/e', meaning "compile a LOWTRAN7/MODTRAN input file named *TEST.INP* in MESH form with ERROR logging and automatically generate a *.MTH* file named *TEST.MTH*". Recall that the MESH (/m) option generates all possible combinations of all perturbed input parameters and the ERROR (/e) option causes a list of active absorbers and their spectral range of activity to be written to a file called *SEN.ERR*, along with any compile time errors.

**Step 19:**

SENTRAN7 then displays a screen similar to the one shown in Figure 37, while it compiles the input cards. The active molecular absorbers in the selected spectral range will be displayed. If the list of absorbers fills more than one screen, the message displayed at the bottom of Figure 37 will be shown.

**Step 20:**

Press RETURN to exit the screen and complete the compile option. At this point, we are back at the Main Menu. We will now want to run the appropriate transmission model.

```

SENTRAN7  SUN4/Unix Version  SPARTA, Inc
                SENTRAN7 EDITING UTILITY
                EDITING CARD 4

THE FOLLOWING PARAMS. CANNOT BE PERTURBED

V1 .....      1299.999   CM-1      7.692 MICRONS
V2 .....      1304.999   CM-1      7.662 MICRONS
DV .....           5.000
IFWHM          1      (REQUIRED FOR MODTRAN ONLY)

ALL PARAMETERS FOR CARD 4 O.K. (Y/N) [Y]

```

Figure 34. Final Screen Displayed After Editing Card 4. Note that SENTRAN7's output format routine causes the spectral frequencies to be rounded off incorrectly. The internal representation of the numbers is still correct

```

SENTRAN7  SUN4/Unix Version  SPARTA, Inc
                SENTRAN7 EDITING UTILITY
                EDITING CARD 4

THE FOLLOWING PARAMS. CANNOT BE PERTURBED

V1 .....      1299.999   CM-1      7.692 MICRONS
V2 .....      1304.999   CM-1      7.662 MICRONS
DV .....           5.000
IFWHM          1      (REQUIRED FOR MODTRAN ONLY)

ALL PARAMETERS FOR CARD 4 O.K. (Y/N) [Y]

COMPILE INPUT DECK? [Y]

```

Figure 35. Example of the Screen Displaying the Compile Option After All Cards Have Been Set

```

SENTRAN7  SUN4/Unix Version  SPARTA, Inc
                DEVELOPING INPUT DECK
                BASED ON LAST EDITING SESSION

                ENTER FILE NAME FOR INPUT DECK [.INP]
                AND SENTRAN7 COMPILE OPTIONS

                ? test/m/e

```

Figure 36. SENTRAN7 Prompt for the Input File Name and Compiler Options

```
SENTRAN7   SUN4/Unix Version                               SPARTA, Inc
              DEVELOPING INPUT DECK
              BASED ON LAST EDITING SESSION

              COMPILING TEST.INP AS MESH  ERSLOG

LIST OF ACTIVE MOLECULAR ABSORBERS (V1= 1300.0 V2= 1305.0)

H2O ACTIVE REGIONS:  1300.0 TO  1305.0 CM-1
CO2 ACTIVE REGIONS:  1300.0 TO  1305.0 CM-1
N2O ACTIVE REGIONS:  1300.0 TO  1305.0 CM-1
CH4 ACTIVE REGIONS:  1300.0 TO  1305.0 CM-1
SO2 ACTIVE REGIONS:  1300.0 TO  1305.0 CM-1
NH3 ACTIVE REGIONS:  1300.0 TO  1305.0 CM-1
...MORE... HIT <RETURN> TO CONTINUE]
```

Figure 37. Example of the On-Line Feedback Provided While SENTRAN7 Compiles the User Specified Input Cards

### 5.3.4 Using the Run Module

SENTRAN7 offers the capability of running LOWTRAN7 or MODTRAN from within the menu interface. (Note that it is the user's responsibility to make sure the desired model is present, although SENTRAN7 will notify the user if it cannot find the desired code.) Follow the next steps in order to run the calculations.

#### Step 1:

The user first selects which code to execute, either LOWTRAN7, MODTRAN or MODTRAN run as LOWTRAN7 by entering '4' at the Main Menu (see Figure 23). The submenu for choosing which code to run will appear as shown in Figure 38. For this case we will run LOWTRAN7, so we will enter '1'. (NOTE: If you only have the code for MODTRAN, then choose option 3 to run MODTRAN as LOWTRAN7).

#### Step 2:

We are now back at the Main Menu. Notice that option 5 to run the code will reflect which option was chosen in the previous submenu (either LOWTRAN7, MODTRAN, or MODTRAN AS LOWTRAN7).

```
SENTRAN7  SUN4/Unix Version  SPARTA, Inc.
SELECT LOWTRAN7/MODTRAN

CURRENT MODE OF EXECUTION :  LOWTRAN7

1 - LOWTRAN7
2 - MODTRAN
3 - MODTRAN AS LOWTRAN7

? 
```

Figure 38. Example of the Screen Displaying the Programs Available

**Step 3:**

We now wish to run LOWTRAN7, therefore we enter '5' or 'run' at the Main Menu prompt.

**Step 4:**

The program will now prompt you for the name of the input file to use for this run, as shown in Figure 39, with the default being the last input file that was compiled (the file created in Section 5.3.3). We will accept the default file (*TEST.INP*) by pressing RETURN.

```
SENTRAN7  SUN4/Unix Version  SPARTA, Inc.
PROGRAM TO BE EXECUTED :  LOWTRAN7

ENTER FILE NAME FOR INPUT DECK [.INP] ?  TEST.INP
```

Figure 39. Example of the Prompt Requesting the Name of the Input File

**Step 5:**

We now wait for the program execution to complete, at which time we will see the screen shown in Figure 40. The time required to complete a run will depend on many factors, such as the speed of the host computer and the type of calculation.

```
SENTRAN7   SUN4/Unix Version   SPARTA, Inc

RUNNING LOWTRAN7 FOR TEST.INP

... PLEASE WAIT ...

EXECUTION COMPLETED

PRESS <RETURN> TO CONTINUE
```

Figure 40. Example of the Screen Displaying the Completion of a LOWTRAN7 Calculation

**Step 6:**

The standard LOWTRAN7 *tape7* and *tape8* have now been created as *TAPE7.OUT* and *TAPE8.OUT*, respectively, and contain the output data for the above case. We can now proceed to the Graph and Analyze Module of SENTRAN7.

**5.3.5 Using the Graph and Analyze Module For Tutorial #1**

Now that we have generated some LOWTRAN7 data, we can proceed to graph and analyze it. Be sure that you have performed the preceding steps of this tutorial and executed LOWTRAN7 so that your results will be consistent with those of this tutorial. Since the G&A Module in SENTRAN7 is fairly versatile, this tutorial is a cursory overview at best. The best way to master the G&A option is by utilizing the on-line help utility and “playing” with LOWTRAN7/MODTRAN data sets. In this section, we will create three plots from the data stored in the *TAPE7.OUT* file from the LOWTRAN7 run just completed.

**Plot 1**

A 3-D plot of the total transmittance as a function of the perturbed parameters RANGE and H1 for a wavenumber of  $1300\text{ cm}^{-1}$ , plotted at a  $45^\circ$  rotation of both axes

## Plot 2

A 3-D plot of the derivative of total transmittance with respect to the RANGE (the  $x$  axis) as a function of the perturbed parameters RANGE and H1 for a wavenumber of  $1300\text{ cm}^{-1}$ , plotted at  $45^\circ$  rotation of both axes

## Plot 3

A 3-D plot of the optical depth (total absorbance) as a function of the perturbed parameters RANGE and H1 for a wavenumber of  $1300\text{ cm}^{-1}$ , plotted at a  $45^\circ$  rotation of both axes

We will begin by creating Plot 1 described above. Follow Steps 1 through 12 to create this plot:

### Step 1:

Type '4' or 'graph' (or some sub-string of the word 'graph', such as 'g') at the Main Menu prompt (see Figure 23). The initial screen displaying the available plots for the input cards defined in the Edit Module will appear, as shown in Figure 41.

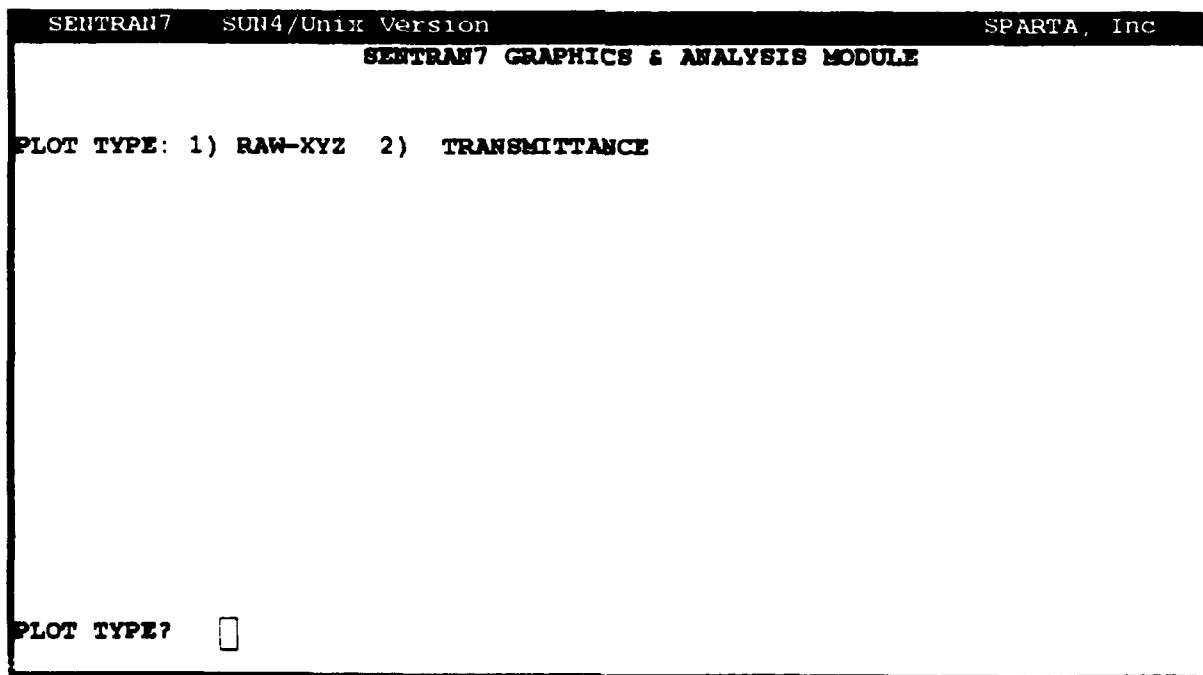

Figure 41. Initial Screen Display for SENTRAN7's Graph and Analyze Module

### Step 2:

We would like to plot a transmittance profile (specifically total transmittance), so in response to the prompt for a plot type, enter a '2'. Figure 42 shows the following screen that will appear. This screen prompts the user for the  $x$  axis parameter.

```
SENTRAN7 : SUN4/Unix Version          SPARTA, Inc
                SENTRAN7 GRAPHICS & ANALYSIS MODULE

PLOT TYPE: TRANSMITTANCE
X-AXIS      : 1) WAVENUMBER  2) RANGE

X-AXIS      
```

Figure 42. Example of the Screen Prompt Displayed Asking for the X Axis Parameter

### Step 3:

We would like the  $x$  axis to be the perturbed parameter RANGE, so enter a '2' in response to the  $x$  axis prompt. The program will now prompt you for the  $y$  axis parameter, as shown in Figure 43.

### Step 4:

We would like the  $y$  axis to be the perturbed parameter H1, so enter a '2' in response to the  $y$  axis prompt. Figure 44 shows the subsequent screen to appear.

### Step 5:

Since we have already used two independent axes for our plot, we must select a fixed wavenumber for our data set. In response to the prompt for wavenumber, type '1300'. The G&A option will then prompt you for the units in which frequency dependent data should be expressed ( $\text{cm}^{-1}$  or microns), as shown in

```
SENTRAN7 . SUN4/Unix Version SPARTA, Inc
SENTRAN7 GRAPHICS & ANALYSIS MODULE

PLOT TYPE: TRANSMITTANCE
X-AXIS : RANGE
Y-AXIS : 1) WAVENUMBER 2) H1

Y-AXIS 
```

Figure 43. Example of the Screen Prompt Displayed for the y Axis Parameter

```
SENTRAN7 . SUN4/Unix Version SPARTA, Inc
SENTRAN7 GRAPHICS & ANALYSIS MODULE

PLOT TYPE: TRANSMITTANCE
X-AXIS : RANGE
Y-AXIS : H1
WAVENUM. : 1300 TO 1305

WHICH WAVENUMBER ? 
```

Figure 44. Example of the G&A Screen Prompting for the Wavenumber

```
SENTRAN7 : SUN4/Unix Version          SPARTA, Inc.
                SENTRAN7 GRAPHICS & ANALYSIS MODULE

PLOT TYPE: TRANSMITTANCE
X-AXIS      : RANGE
Y-AXIS      : H1
WAVENUM.    : 1300
UNITS OF    : 1) CM-1  2) MICRONS

UNITS ?    
```

Figure 45. Example of the G&A Screen Prompting for the Units to Use in Plotting

Figure 45.

**Step 6:**

Select '1', for  $\text{cm}^{-1}$ .

**Step 7:**

You will now be presented with a number of items which may be plotted on the z axis, as shown in Figure 46. The actual choices presented will vary according to the type of calculation which you are performing (based on IEMSCCT's value). Recall that we want to plot total transmittance as a function of RANGE and H1, so select item '1' to plot TOTAL TRANSMITTANCE.

**Step 8:**

The final step in the data selection process involves choosing the file from which to read the LOWTRAN7 output data, as shown in Figure 47. In almost all cases the user just needs to accept the default file, either *TAPE7.OUT* or *TAPE8.OUT*. In this case we will accept the default *TAPE7.OUT* by pressing RETURN. You have completed the data selection portion of the G&A option, and the program will now enter the G&A command mode.

**Step 9:**

At the command line, you can obtain a list of available G&A commands by

```

SENTRAN7      SUN4/Unix Version      SPARTA, Inc
SENTRAN7 GRAPHICS & ANALYSIS MODULE

PLOT TYPE: TRANSMITTANCE
X-AXIS   : RANGE
Y-AXIS   : H1
WAVENUM. : 1300
UNITS OF : CM-1
Z-AXIS   :  1) TOTAL    2) H2O      3) UNIF    4) O3      5) TRACE
           6) N2 CONT  7) H2O CONT  8) MOL SCAT 9) AER HYD 10) HNO3
           11) AER ABS 12) LOG TOTAL 13) CO2     14) CO     15) CH4
           16) N2O    17) O2      18) NH3    19) NO     20) NO2
           21) SO2

WHICH TRANSMITTANCE ? 

```

Figure 46. Example of the G&A Screen Prompting for the Selection of the Z Axis Parameter

```

SENTRAN7      SUN4/Unix Version      SPARTA, Inc
SENTRAN7 GRAPHICS & ANALYSIS MODULE

PLOT TYPE: TRANSMITTANCE      FILE NAME :  TAPE7.OUT
X-AXIS   : RANGE
Y-AXIS   : H1
WAVENUM. : 1300
UNITS OF : CM-1
Z-AXIS   : TOTAL TRANSMITTANCE

```

Figure 47. Example of the G&A Screen Prompting for the Name of the Data File to Plot

typing 'help'. Figure 48 shows the help screen that will appear.

**Step 10:**

To obtain specific information on any of the G&A commands, you type 'help' and the command you wish information on. For example, type 'help plot' as shown in Figure 49. The program will display the available help for the PLOT command, as shown in Figure 50.

**Step 11:**

If you have a VT240 type terminal, try plotting the data by entering 'plot VT240'. If you do not have a VT240 compatible terminal, plot the graph to a file first by typing 'plot test', this will create the Tektronix file *TEST.TEK*. In either case, the cursor will move to a new field and request rotation angles, as shown in Figure 51. Enter '45,45' meaning "first rotate the data counterclockwise about the z axis and then rotate the data counterclockwise around the original x axis (*i.e.*, tilt out of screen)". Your plot should look like Figure 52.

**Step 12:**

If you were able to plot the graph to the screen using the VT240 command, press the RETURN key when you are done looking at the plot. If you plotted the graph to a file (*TEST.TEK*), you know the plot has been completed when the comment ".TEK FILE : TEST.TEK" appears on the left of the screen and you return to the G&A command line, as shown in Figure 53.

We will now graph Plot 2, a 3D plot of the derivative of total transmittance with respect to the RANGE (the x axis) versus the perturbed parameters RANGE and H1 for a wavenumber of  $1300\text{ cm}^{-1}$ , plotted at  $45^\circ$  rotation of both axes. Step 13 accomplishes this task:

**Step 13:**

Differentiate with respect to the x axis by entering 'dx' at the command line. Note that the program modifies the z axis label to reflect this manipulation. Let's plot the data set by typing 'plot VT240' (or 'plot testdx' if plotting to a file). Press the RETURN key to accept the default rotation arguments, which should be '45,45'. The resultant plot should look like Figure 54.

We will now graph Plot 3, a 3-D plot of the optical depth (total absorptance) versus the perturbed parameters RANGE and H1 for a wavenumber of  $1300\text{ cm}^{-1}$ , plotted at  $45^\circ$  rotation of both axes. Follow Steps 14 and 15 to create this plot:

**Step 14:**

Recall that to obtain the optical depth data we use the T2A command to trans-

```

SENTRAN7  SUR14, Unix Version  SPARTA, Inc
SENTRAN HELP UTILITY

Help is available on the following commands :
    A2T      DXDY      MINIMUM  TITLE
    COSMETIC DYDX      NEW       T2A
    DX       EXIT      NOSORT    WRITE
    DY       LOG       PLOT      XLABEL
    DDX      MAXIMUM   REFRESH   YLABEL
    DDY      MEAN      SWAP      ZLABEL

Enter HELP [command you want help on] at the COMMAND prompt

EXAMPLE:  HELP T2A

                HIT <RETURN> TO CONTINUE

```

Figure 48. Example of the Screen Displaying the "Help" Options Available for Graph and Analyze Commands

```

SENTRAN7  SUR14, Unix Version  SPARTA, Inc
SENTRAN7 GRAPHICS & ANALYSIS MODULE

PLOT TYPE: TRANSMITTANCE      FILE NAME : TAPE7.OUT
X-AXIS   : WAVENUMBER
Y-AXIS   : RANGE

UNITS OF : CM-1
Z-AXIS   : TOTAL TRANSMITTANCE

COMMAND ? help plot

```

Figure 49. Example of the G&A Screen Showing a Request for "Help" on the PLOT Command

```
SENTRAN7  SUN4/Unix Version  SPARTA, Inc
SENTRAN HELP UTILITY

The PLOT command initiates the plotting sequence. PLOT requires
at least one argument. The argument will generally be a .TEK
output file. However, the name VT240 is a reserved argument
which will send graphical output to the terminal. An output
file name and the VT240 argument can both be provided, causing
output to be directed to the screen and the .TEK file simultaneously.

EXAMPLE :

PLOT TEST VT240

Will form a graphics file TEST.TEK and display the plot on the user's
terminal. After the PLOT command is entered, the user is prompted for
rotation angles. PLOT then proceeds and returns to COMMAND input when
finished.

HIT <RETURN> TO CONTINUE
```

Figure 50. Example of the Screen Showing "Help" Information About the PLOT Command

```
SENTRAN7  SUN4/Unix Version  SPARTA, Inc
SENTRAN7 GRAPHICS & ANALYSIS MODULE

PLOT TYPE: TRANSMITTANCE          FILE NAME : TAPE7.OUT
X-AXIS   : RANGE
Y-AXIS   : H1                     ROTATION  : 45, 45
WAVENUM. : 1300
UNITS OF : CM-1
Z-AXIS   : TOTAL TRANSMITTANCE

COMMAND ? plot test
```

Figure 51. Example of the G&A Screen Prompting for Rotation Angles to be Used While Plotting

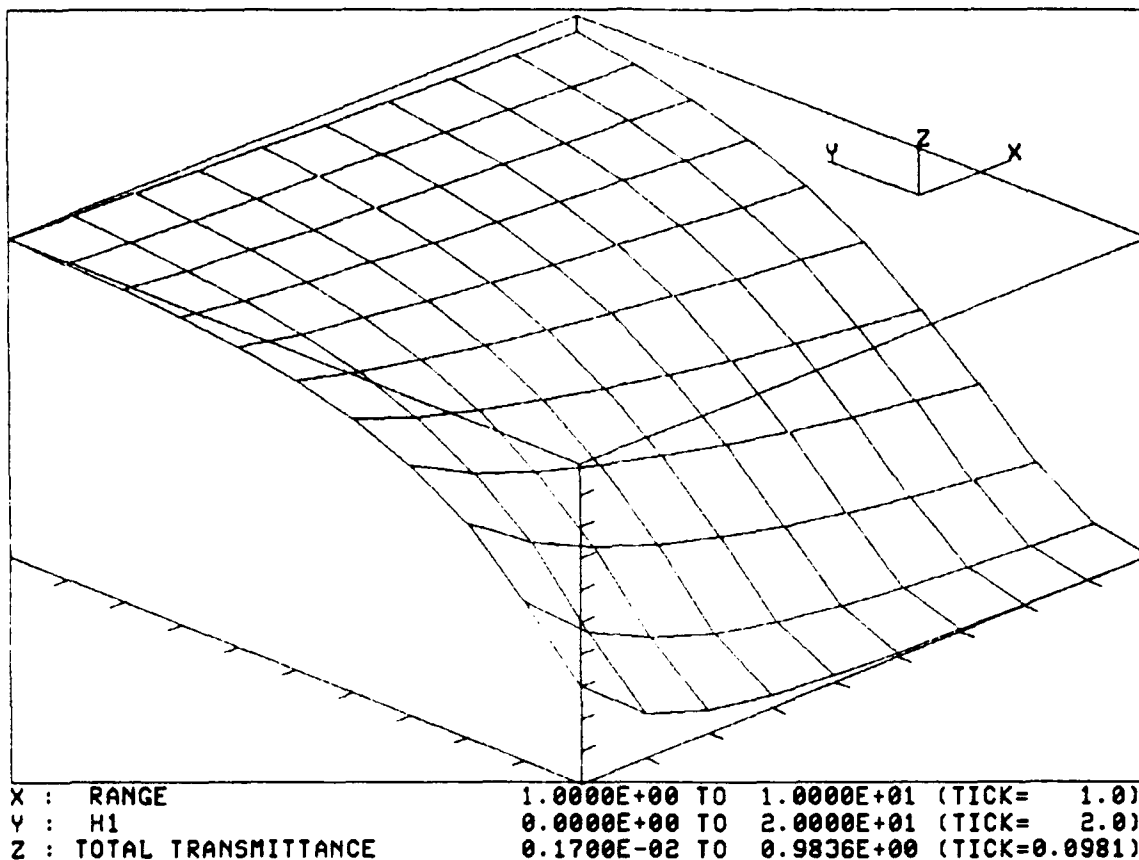

Figure 52. Example of Plot 1, a 3-D Plot of Total Transmittance as a Function of H1 and RANGE for a 45° Rotation of Both Axes

form the z axis transmittance data to optical depth. Since our z axis is currently the derivative of transmittance, we first need to refresh the data so that we have total transmittance on the z axis again. This can be done by first typing 'new' at the command line prompt. The initial G&A screen will appear (see Figure 41). Re-answer all of the data input options (*i.e.*, Repeat Steps 2 through 8 of the G&A Module for Tutorial #1) so that you have the perturbed parameters RANGE and H1 for the x and y axes, respectively, and TOTAL TRANSMITTANCE on the z axis.

**Step 15:**

Type 't2a' to convert the z axis transmittance values to optical depth values. Type 'plot VT240' and then '45,45' to see the results shown in Figure 55.

Again, try seeing which commands are available by typing 'help'. Experiment with the data set by trying as many of these commands as you can, using the on-line help whenever you have difficulties.

```

SENTRAN7  SUN4/Unix Version  SPARTA, Inc
SENTRAN7 GRAPHICS & ANALYSIS MODULE

PLOT TYPE: TRANSMITTANCE          FILE NAME : TAPE7.OUT
X-AXIS   : RANGE                  .TEK FILE  : TEST.TEK
Y-AXIS   : H1                     ROTATION  : 45.00  45.00
WAVEENUM : 1300
UNITS OF : CM-1
Z-AXIS   : TOTAL TRANSMITTANCE

COMMAND ? 

```

Figure 53. Example of the G&A Screen Displayed When the Requested Graph Has Been Plotted to a File

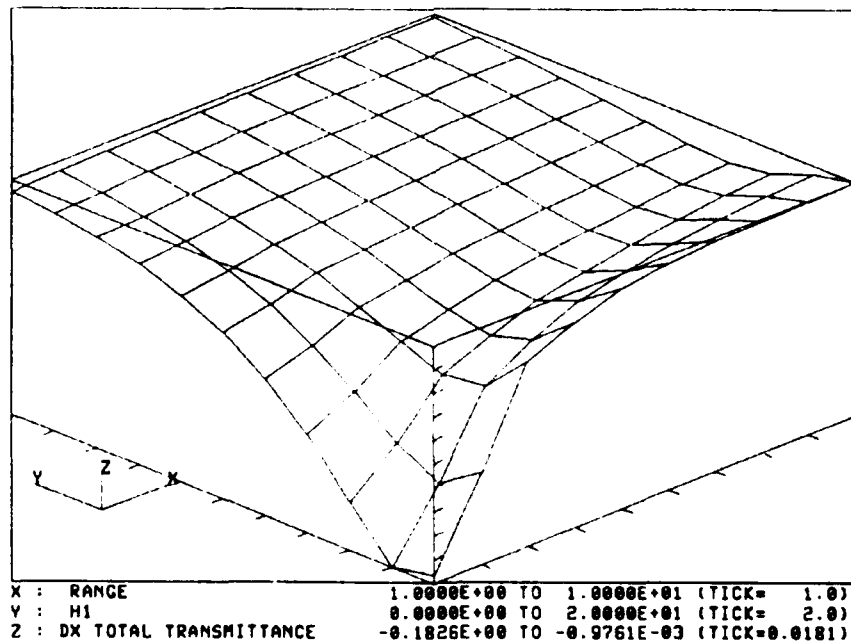

Figure 54. Example of Plot 2, a 3-D Plot of Derivative of Total Transmittance With Respect to RANGE as a Function of RANGE and H1 for a 45° Rotation of Both Axes

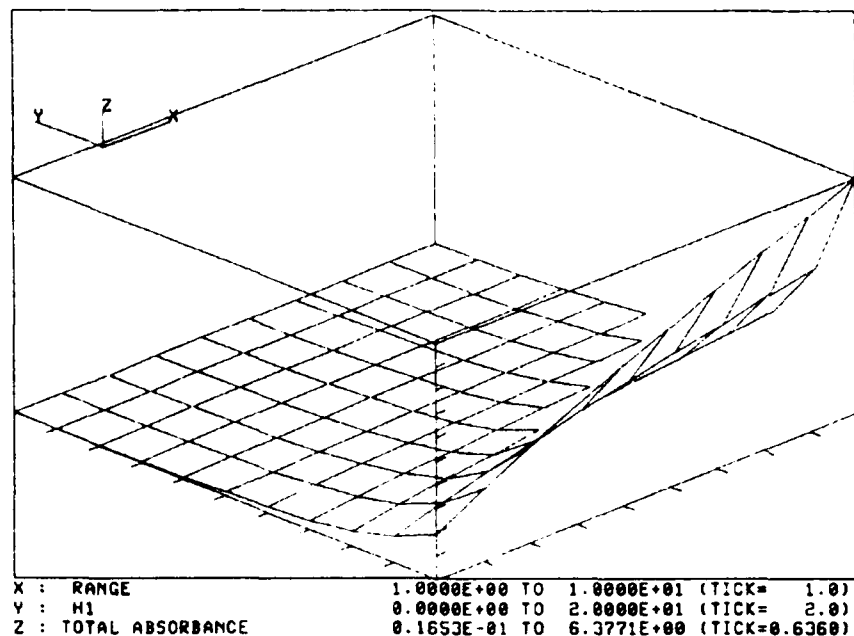

Figure 55. Example of Plot 3, a 3-D Plot of Optical Depth as a Function of RANGE and H1 for a 45° Rotation of Both Axes

#### 5.4 SENTRAN7 Tutorial #2

The following tutorial is not in as much depth as the first tutorial given in that a step-by-step discussion will not be given as with the first tutorial. Instead, the input parameters for this tutorial are specified for you to enter with SENTRAN7's Edit Module. Examples of the G&A features and some of the possible plots are shown.

##### 5.4.1 Using the Edit Module

We will begin by editing the input cards to generate the following test case:

*Thermal Radiance with single scattering for models 6 (U.S. Standard), 3 (Midlatitude Winter) and 1 (Tropical Atmosphere) and a vertical path from 0 to 32 km with IHAZE = 1, over 400 to 2000  $\text{cm}^{-1}$  spectral region at 5  $\text{cm}^{-1}$  intervals*

Figure 56 summarizes the input parameters for this test case. The steps that follow briefly outline the instructions for editing the input cards in SENTRAN7 in order to generate the test case described above.

##### Step 1:

Type either '2' or 'edit' at the Main Menu (see Figure 23) in order to enter the Edit Module of SENTRAN7. The screen for editing Card 1 will appear (see Figure 24).

|  |   |
|--|---|
| <p><b>CARD 1</b><br/>-----<br/>MODEL = 6 3 1<br/>ITYPE = 2<br/>IEMSCT = 1<br/>IMULT = 0<br/>M1=M2=M3=M4=M5=M6=MDEF=0<br/>IN = 0<br/>NOPRT = -1<br/>TBOUND = SALB = 0.0</p> <p><b>CARD 3</b><br/>-----<br/>H1 = 0.0<br/>H2 = 32.0<br/>ANGLE = 0.0<br/>RANGE = 0.0<br/>BETA = RD = 0.0<br/>LEN = 0</p> | <p><b>CARD 2</b><br/>-----<br/>IHAZE = 1<br/>ISEASN = 1<br/>IVULCN = 1<br/>ICSTL = ICLD = IVSA = 0<br/>VIS = WSS = WHH = 0.0<br/>RAINRT = 0.0<br/>GNDALT = 0.0</p> <p><b>CARD 4</b><br/>-----<br/>V1 = 400.0<br/>V2 = 2000.0<br/>DV = 5.0<br/>IFWHM = 1</p> |
|--|---|

Figure 56. Summary of Input Parameters for Tutorial #2

**Step 2:**

For the MODEL parameter we wish to use three different models, U.S. Standard, Midlatitude Winter and Tropical Atmosphere, so enter '6 3 1' on the first line of Card 1.

**Step 3:**

ITYPE will now be the active line. Enter '2' to indicate a vertical path between two altitudes.

**Step 4:**

For IEMSCT, enter '1' to execute the program in radiance mode.

**Step 5:**

Set IMULT equal to '0' for single scattering.

**Step 6:**

Hit RETURN until you reach the line containing the NOPRT parameter. Enter '-1' so that data will be written to *TAPE8.OUT* as well as *TAPE7.OUT*. *TAPE8.OUT* will contain data for the differential transmittance (DTAU) and the Black Body Function.

**Step 7:**

We are now done editing Card 1. Enter 'pd' to advance to Card 2. Verify that the parameters on Card 1 match those summarized in Figure 56 for Card 1. If they do, accept Card 1 by hitting RETURN. If they do not, enter 'n' and repeat Steps 2 through 7 of this tutorial.

**Step 8:**

We will now be editing Card 2. IHAZE will be the active line in Card 2. We will use the Rural Extinction aerosol model, so enter '1' for IHAZE.

**Step 9:**

ISEASN will be the active line; enter '1' for a Spring - Summer aerosol profile season.

**Step 10:**

Enter '1' for IVULCN to select a background stratospheric profile and extinction.

**Step 11:**

The rest of the parameters on Card 2 should be set to '0'. If they are, enter 'pd' to advance to Card 3. If they are not, continue editing Card 2 and set these variables to '0'. Again check the contents of your Card 2 with the summary of input parameters in Figure 56 for Card 2. If they are correct, accept the contents of Card 2 by hitting RETURN. If they do not, enter 'n' and repeat Steps 8 through 11.

**Step 12:**

We will now be editing Card 3, with H1 being the active line. We wish to use a vertical path from 0 to 32 km, so enter '0' for H1.

**Step 13:**

Then enter '32' for H2.

**Step 14:**

The rest of the parameters on Card 3 should be set to '0'. If they are, enter 'pd' and accept Card 3 after comparing the contents of your card to the summary given in Figure 56 for Card 3.

**Step 15:**

This will advance us to Card 4. We wish to perform calculations over a 400 to 2000  $\text{cm}^{-1}$  spectral region at 5  $\text{cm}^{-1}$  intervals. So for the initial frequency V1, enter '400'. The program will automatically reformat the line and display V1 in  $\text{cm}^{-1}$  and microns.

**Step 16:**

For the final frequency V2, enter '2000'.

**Step 17:**

For the frequency increment DV, enter '5'.

**Step 18:**

We are done editing Card 4. Enter 'pd' and accept the contents of Card 4. Note that we are not concerned with the value of IFWHM since we will be running LOWTRAN7 and not MODTRAN.

**Step 19:**

Once we have accepted Card 4, SENTRAN7 will prompt you if you want to compile the input parameters. Accept the default 'y' by hitting RETURN so that we now enter the Compile Module of SENTRAN7.

**5.4.2 Using the Compile and Run Modules****Step 20:**

The program now prompts you for the name of the input file (\*.INP) to create and for the compiler options. Compile the input parameters to produce the file TEST2.INP in NOMESH form without ERROR logging by entering 'test2 /nomesh'.

**Step 21:**

After the program finishes compiling the input file, SENTRAN7 returns to the Main Menu. We can now run LOWTRAN7 for the test case we have just created. Make sure that Option 5 on the Main Menu says *RUN LOWTRAN7* (or *RUN MODTRAN as LOWTRAN7*). If it does not, first choose Option 4 to *SELECT LOWTRAN7/MODTRAN* and select LOWTRAN7 (or MODTRAN as LOWTRAN7) from the subsequent submenu.

**Step 22:**

We are now ready to execute LOWTRAN7, so enter '5' or 'run' at the Main Menu prompt. Wait for the program to notify you that execution has completed before hitting RETURN and returning to the Main Menu (see Figure 40).

**5.4.3 Using the Graph and Analyze Module for Tutorial #2**

We wish to create two plots from the data created from Tutorial #2:

**Plot 1**

A 3-D plot of the total transmittance as a function of wavenumber and the perturbed parameter MODEL, plotted at viewing angles of  $-11.25^\circ$  and  $11.25^\circ$

**Plot 2**

A 3-D plot of the differential transmittance (DTAU) as a function of layer and wavenumber for a Midlatitude Winter atmosphere, plotted at viewing angles of  $-45^\circ$  and  $11.25^\circ$

Follow these steps to create these plots and compare your results with Figures 57 and 58.

**Step 23:**

Enter the G&A Module by entering '6' or 'graph' at the Main Menu. The initial screen and types of plots available for this case are shown in Figure 59.

**Step 24:**

We first want to create Plot 1. The option to plot total transmittance can be found under the ATM RADIANCE plot type, so enter '2' for this plot type at the command prompt. Let the x axis be the wavenumber in units of  $\text{cm}^{-1}$  and the y axis be the different model numbers. Then let the z axis be total transmittance. Read in the *TAPE7.OUT* file and plot the data with rotation angles of  $-11.25^\circ$  and  $11.25^\circ$ . This plot is shown in Figure 60.

**Step 25:**

We next want to create Plot 2. We first need to refresh the data set by typing 'new' at the G&A command prompt to return to the initial G&A menu. Now choose the plot type to plot DTAU by entering a '3'. Note that the x axis parameter is automatically set to LAYER # and the y axis parameter is set to WAVENUMBER. Choose the  $\text{cm}^{-1}$  units at the prompt for the units. For the z axis we can choose to plot DTAU or DTAU/LAYER THICKNESS. We want to plot DTAU, so enter '1' at the prompt for the z axis parameter. Read in *TAPE8.OUT* and plot the graph with rotation angles of  $-11.25^\circ$  and  $11.25^\circ$ . This plot is shown in Figure 61. Note that the x axis increases into the foreground. Also note that the program can ONLY plot the first group of data in the output file (MODEL = 3), and does not plot the cases for MODEL = 6 or 1. Any time DTAU, the Black Body Function or the Flux plots (IEMSCT = 2) are plotted, only the first perturbation case in the output file is plotted. Which perturbation case is first in the output file depends on if the input file was compiled as NOMESH or MESH. To plot these other cases you must edit the input cards so that the desired perturbation to plot is first and then compile the input cards as MESH. For best results when plotting layerwise plots such as this, the user should not use any perturbations but simply edit the input cards for one particular case to plot.

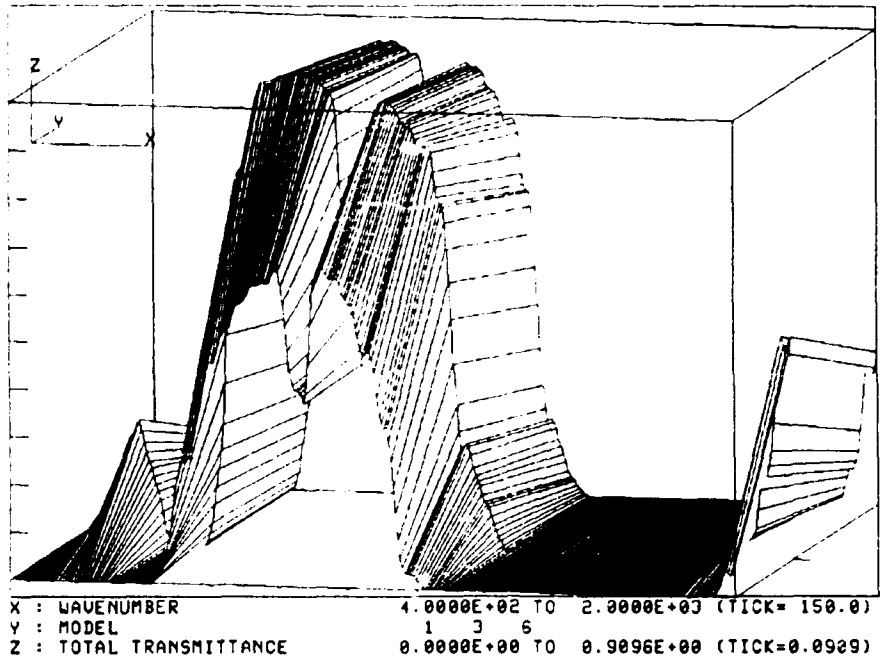

Figure 57. Example of Plot 1, a 3-D Plot of Total Transmittance as a Function of Wavenumber and Model Atmosphere Number for Viewing Angles of  $-11.25^\circ$  and  $11.25^\circ$

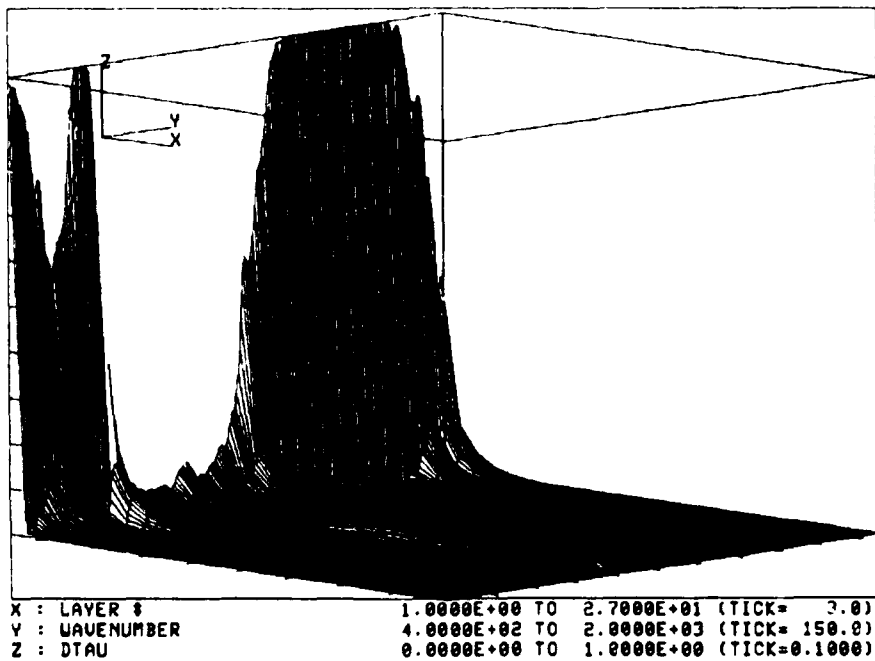

Figure 58. Example of Plot 2, a 3-D Plot of Differential Transmittance as a Function of Layer Number and Wavenumber, for a Midlatitude Winter Atmosphere and Viewing Angles of  $-45^\circ$  and  $11.25^\circ$

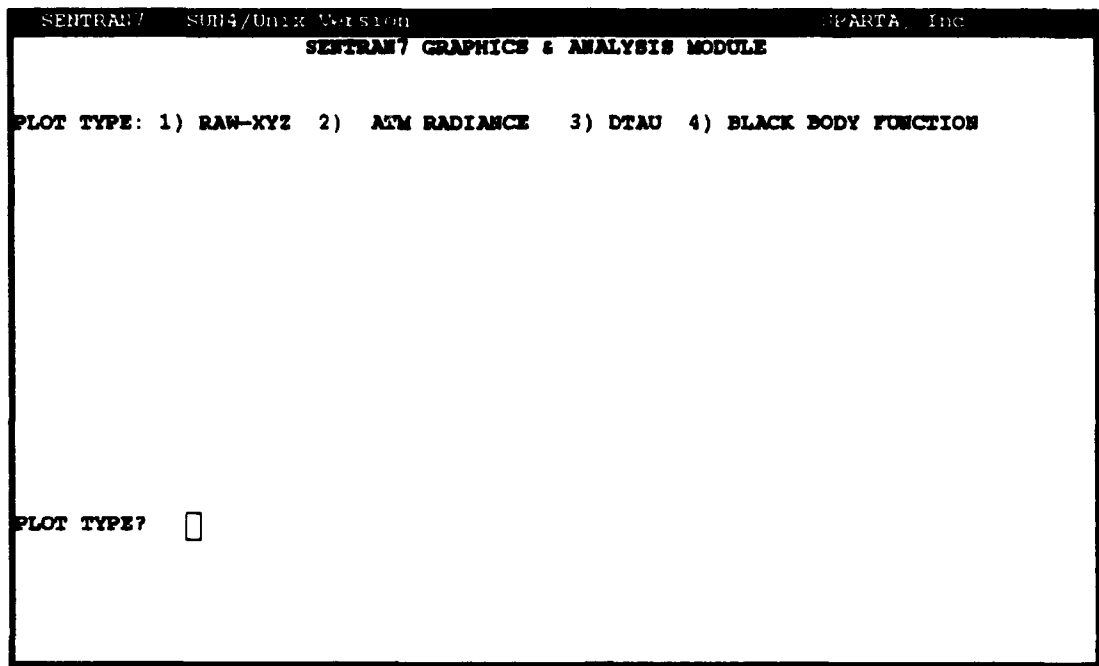

Figure 59. Example of the Initial Screen for SENTRAN7 Graph and Analyze Features for Tutorial #2

## 6 PROTOTYPE SENSITIVITY PACKAGE FOR FASCOD3, SENCODE

In a parallel effort, a "beta" version of a sensitivity package for FASCOD3<sup>5</sup> has been developed. This package, which is not part of SENTRAN7, has been named SENCODE (SENSitivity analysis for fasCODE). The purpose of the effort was to demonstrate that such a package is possible and to provide a cornerstone for future work and upgrades. Due to time and resource constraints, only some of the features of SENTRAN7 have been included in SENCODE. Also, the card sequence in the Edit Module was developed before FASCOD3's input stream was finalized, so some new options in FASCOD3 are not available in SENCODE, such as the cross section feature. This chapter briefly describes the features of SENCODE, although a public release version is not available. Furthermore, readers are reminded that only a preliminary version of FASCOD3, FASCOD3P, is currently available and the complete Users Guide for FASCOD3 has not yet been released. Explanation of the FASCOD3 variables and card options discussed below is available only as part of the Users instructions.

### 6.1 Framework of SENCODE

The framework for SENCODE is analogous to SENTRAN7. Users are able to develop, load, save, and compile methodology files. These methodology files are **not** compatible with SENTRAN7 methodology files. The Run Module and the Graph and Analyze Module in SENTRAN7 are not included in the beta version of SENCODE. The Run Module was removed because FASCOD3 often executes slowly, which defeats the purpose of an on-line run feature. Also, a well-conceived Run Module should initially confirm that a user-supplied *TAPE3* linefile covers the frequency interval of the FASCOD3 calculation, which was beyond the scope of this effort. (The *TAPE3* linefile contains high resolution molecular absorption data used by FASCOD3.) The Graph and Analyze Module was also not included. Specifically, the FASCOD3 output file scheme is far more complicated than the output generated by LOWTRAN7, so the existing Graph and Analyze Module would require considerable code modification. Additionally, the output from FASCOD3 may exceed the internal plotting capabilities developed for SENTRAN7. Effectively then, the current version of SENCODE only permits users to perturb certain input parameters and then set up an input file for multiple runs of FASCOD3.

### 6.2 Input Restrictions

The SENCODE Edit Module mimics the flow through the FASCOD3 input card images. Given the complicated nature of FASCOD3 input cards, this can be an extremely useful tool in itself. However, the FASCOD3 input cards are far more lengthy than LOWTRAN7 input cards. Therefore, the current version of SENCODE only permits input parameters on some cards to be perturbed. Table 17 lists

the perturbation options available in SENCODE. Some of these restrictions arise from time constraints and, hopefully, can be relaxed in future efforts. Other input parameters, especially on Card 1.2, cannot be perturbed because their perturbation creates different flows through the FASCOD3 input card images.

Data for some FASCOD3 input cards, such as the trace gas profiles, cannot be entered easily within SENCODE because they involve excessive amounts of terminal input. For these card series, data are read from external files with default extensions. These files must be created off-line by the user. For reference, Table 18 gives the card series read from external files and their default extensions. The format of the external files should match the format of the FASCOD3 input cards that they are meant to represent. As part of the initial testing of SENCODE, the code was able to read sample external files for each long card series and then create "readable" input cards for FASCOD3.

### 6.3 Additional Comments

A fair amount of time was spent insuring that SENCODE properly creates input card images for FASCOD3. To do this, numerous FASCOD3 options were exercised via SENCODE's Edit and Compile Modules. In all cases, FASCOD3 was able to read the input file created by SENCODE, and produce (what appears to be) meaningful output in *TAPE6.DAT*. However, SENCODE should not be viewed as an interface for producing crash-proof FASCOD3 runs. Users can go astray in their analyses because:

1. Meaningful limits on some input parameters depend on the precise path geometry, which is difficult to check for.
2. For some input parameters, only FASCOD3 can determine if the specified value is "proper". FASCOD3 users often have to run the code a few times to make sure everything is okay, especially for the atmospheric layering.
3. Some variable names, such as NPTS, appear on more than one input card, but take on different meanings.
4. Input parameters on some FASCOD3 cards are inheritly related to those on other cards. SENCODE performs limited checking between cards for internal consistency.

Thus, it's quite possible that SENCODE users can cause FASCOD3 to bomb during execution. The point here is that users still need to know a great deal about FASCOD3 when using SENCODE.

Table 17. Perturbation Options in the Beta Version of SENCODE. Recall that SENCODE was developed from a more preliminary version of FASCOD3P, so some FASCOD3 options are not available and some card numbers may need to be updated

| CARD NUMBER     | PERTURBATION PERMITTED | COMMENT                                 |                            |
|-----------------|------------------------|---|----------------------------|
| 1.1             | No                     | Character data                          |                            |
| 1.2             | No                     |   |                            |
| 1.2.1           | No                     |   |                            |
| 1.3             | No                     |   |                            |
| 1.4             | No                     |   |                            |
| 1.5             | No                     |   |                            |
| 1.5.1           | No                     |   |                            |
| 1.5.2           | No                     |   |                            |
| 1.5.3           | No                     |   |                            |
| 2.1             | Yes                    | MODEL parameter only                    |                            |
| 2.2 (ITYPE=1)   | Yes                    | All parameters except LEN               |                            |
| 2.2 (ITYPE=2,3) | Yes                    |   |                            |
| 2.3A            | Yes                    |   |                            |
| 2.3B            | No                     |   |                            |
| 2.4             | No                     |   | Not meaningful to perturb  |
| 2.5             | Yes                    |   | Percent perturbations only |
| 2.6.1 .. 2.6.N  | Yes                    |   | Percent perturbations only |
| 3.1             | Yes                    | Some restrictions on IHAZE, ICLD, IVSA  |                            |
| 3.2             | Yes                    |   |                            |
| 3.3             | Yes                    |   |                            |
| 3.4             | No                     |   | Character data             |
| 3.5.1 .. 3.5.N  | Yes                    |   |                            |
| 3.6             | Yes                    |   |                            |
| 4.1 .. 4.N      | Yes                    | Nominal value must equal V1 on CARD 1.3 |                            |
| 5               | No                     |   |                            |
| 6.1             | No                     |   |                            |
| 6.2             | No                     |   |                            |
| 6.3 .. 6.N      | No                     |   |                            |
| 7.1             | No                     | Only one 7.1 is permitted               |                            |
| 8.1             | No                     | Only one 8.1 is permitted               |                            |
| 9.1             | No                     | Only one 9.1 is permitted               |                            |
| 9.2             | No                     |   |                            |
| 9.3 .. 9.N      | No                     |   |                            |
| 10.1            | No                     | Not available in SENCODE                |                            |

Table 18. External Data Files Used By the Beta Version of SENCODE to Represent Long FASCODE Card Series

| <b>CARD SERIES</b>                        | <b>FILE EXTENSION</b> | <b>CONTENTS</b>  |
|---|-----------------------|--|
| 1.5<br>1.5.1<br>1.5.2<br>1.5.3            | <i>LAY</i>            | Layer input data for molecules<br><i>i.e.</i> , column densities |
| 2.3B                                      | <i>BMX</i>            | Altitudes for FSCATM layer boundaries                            |
| 2.4<br>2.5<br>2.6.1 .. 2.6.N              | <i>PRO</i>            | User defined atmospheric profiles                                |
| 3.4, 3.5.1 .. 3.5.N                       | <i>HAZ</i>            | Aerosol or cloud profiles  |
| 3.6                                       | <i>AER</i>            | Aerosol wavelength scaling factors                               |
| 6.2, 6.3 .. 6.N<br>and<br>9.2, 9.3 .. 9.N | <i>FLT</i>            | Filter function data   |

## **7 SUMMARY AND RECOMMENDATIONS FOR FUTURE STUDIES**

### **7.1 Summary**

The main thrust of this effort was to upgrade the original SENTRAN code for use with LOWTRAN7. The new sensitivity analysis package has been named SENTRAN7. SENTRAN7 contains all of the features of the original SENTRAN code including:

1. Interactive entry of LOWTRAN7 input parameters and directives for their perturbations.
2. Intelligent generation of LOWTRAN7 input card images.
3. Autonomous post-processing of LOWTRAN7 outputs for data extraction, analysis and graphical display.
4. An on-line help utility.

Additionally, a number of new features are available in SENTRAN7 such as:

1. Compatibility with the moderate resolution code MODTRAN.
2. An on-line run feature for LOWTRAN7 and MODTRAN.
3. Screen display of available methodology and other input files.
4. Safeguards to prevent existing files from being overwritten.
5. Increased portability across hardware platforms.
6. An on-line help feature within the Edit Module.
7. Tick marks on plots.
8. A plot option for trace gas profiles.

In a parallel effort, a beta version of a sensitivity package for FASCOD3 was developed and named SENCODE. Although this package is not available for public release, initial testing suggests that the full development of such a package is possible.

### **7.2 Recommendations for Future Studies**

#### **7.2.1 Future Work on SENTRAN7**

The current version of SENTRAN7 can adequately serve as a sensitivity analysis tool for LOWTRAN7 and MODTRAN, but a number of enhancements to the program are possible. These changes would provide users with an improved user interface system and additional analysis capabilities. Some of the action items should include

1. Developing routines that check user-defined atmospheres (Card 2C series) for physical consistency, especially when pressure, temperature, and/or water vapor are perturbed.

2. Developing a procedure for specifying random or uncorrelated perturbations from layer to layer in the atmosphere.
3. Providing additional help information in the Edit Module to inform users which LOWTRAN7 input parameters are required for a given problem.
4. Providing warning messages of illegal perturbation values, such as %900 for temperature, upon data entry. Currently, erroneous values are only rejected during compilation.
5. Adding the capability to determine the numerical values at various locations on SENTRAN7 plots.
6. Extend the analysis capabilities, such as curve fitting and mathematical manipulation (*e.g.*, linear operations) of the LOWTRAN7 output data.

Finally, SENTRAN7 should be made available to more researchers in the scientific community so they can provide constructive feedback. That is, improvements to SENTRAN7, especially in the Graph and Analyze Module, should be designed to satisfy the needs of the maximum number of prospective users.

### **7.2.2 Future Work on SENCODE**

The beta version of SENCODE is incomplete and additional work must be performed on it. The goal of future studies should be to get SENCODE to the point where it performs like SENTRAN7. Specifically, future studies should include the following items:

1. Making SENCODE compatible with all FASCOD3 options.
2. Adding an on-line help option in the Edit Module.
3. Providing a Graph and Analyze Module for viewing FASCOD3 sensitivity analyses.

The last item is a formidable task because it involves reading FASCOD3 output files. For simplicity, the Graph and Analyze Module should initially be able to interpret the laser line option because these results are always written to FASCOD3's *TAPE6* file as formatted output. To interpret standard FASCOD3 output, one possible route is through FASCOD3's internal plot option. Specifically, the input parameter JOUT on Card 10.3A can be hard-wired such that FASCOD3 writes plot values to a file as formatted output. In turn, these formatted files could be read by SENCODE using routines like those that read *tape7* and *tape8* in SENTRAN7. Because many types of plots can be generated by FASCOD3 (*i.e.*, transmittance, radiance), a major part of developing a Graph and Analyze Module will be to:

1. Generate a sequence of prompts that ask users what they want to graph and analyze, based on the problem they specified

2. Get SENCODE to read FASCOD3 output files and then plot the quantity (*i.e.*, optical depth, transmittance or radiance) requested by the user.

## References

1. Kneizys, F.X., Shettle, E.P., Abreu, L.W., Chetwynd, J.H., Anderson, G.P., Gallery, W.O., Selby, J.E.A, and Clough, S.A. (1988) *Users Guide to LOWTRAN7*, Air Force Geophysics Laboratory, Hanscom AFB, MA, AFGL-TR-88-0177, ADA206773.
2. Kneizys, F.X., Shettle, E.P., Gallery, W.O., Chetwynd, J.H., Abreu, L.W., Selby, J.E.A., Clough, S.A., and Fenn, R.W. (1983) *Atmospheric Transmittance/Radiance: Computer Code LOWTRAN 6*, Air Force Geophysics Laboratory, Hanscom AFB, MA, AFGL-TR-83-0187, ADA137796.
3. Tomiyama, K. and Hogan, M. (1988) *Sensitivity Evaluation Plan for LOWTRAN*, Department of Electrical Engineering, The Pennsylvania State University.
4. Berk, A., Bernstein, L.S., and Robertson, D.C. (1989) *MODTRAN: A Moderate Resolution Model for LOWTRAN7*, Air Force Geophysics Laboratory, Hanscom AFB, MA, AFGL-TR-89-0122, ADA214337.
5. Clough, S.A., Kneizys, F.X., Anderson, G.P., Shettle, E.P., Chetwynd, J.H., Abreu, L.W., Hall, L.A., and Worsham, R.D. (1989) *FASCOD3: Spectral Simulation in IRS' 88: Current Problems in Atmospheric Radiation*, J. Lenoble and J.F. GeLeyn (Eds.), A. Deepak Publishing, Hampton, VA, pp. 372-375.
6. Tektronix, Inc. (1977) *Users Guide and Service Manual for 4014, 4014-1 Terminals*, Tek Part No. 070-1647-00, Beaverton, OR.
7. ANSI Standard X3.64 (1979) *Additional Controls for Use With ASCII*, Secretariat: CBEMA, 1828 L St., N.W., Washington, DC.

## Appendix A

### File Structure

There are several types of files associated with the SENTRAN7/LOWTRAN7 system. Table A-1 contains the file types and their default extensions along with which program produces which files. The length of a file name is restricted to 20 characters. If the user enters a file name containing more than 20 characters, SENTRAN7 will truncate the file name to the first 20 characters. The structure and use of each type of file is discussed in detail here.

Table A-1. Default File Names Associated With SENTRAN7

| FILE NAME<br>AND EXTENSION | ORIGIN           | CONTENTS  |
|----------------------------|------------------|---|
| *.MTH                      | SENTRAN7         | Methodology files   |
| *.JNP                      | SENTRAN7         | LOWTRAN7/MODTRAN input files                                    |
| *.PRO                      | User             | Model atmosphere data ( <i>i.e.</i> , Card 2C series)           |
| *.AER                      | User             | Aerosol extinction coefficients ( <i>i.e.</i> , Card 2D series) |
| *.PHS                      | User             | Aerosol phase functions ( <i>i.e.</i> , Card 3B series)         |
| *.OUT                      | LOWTRAN7/MODTRAN | Output data used for plotting                                   |
| *.3D                       | User/SENTRAN7    | Raw <i>x, y, z</i> data   |
| *.TEK                      | SENTRAN7         | Tektronix graphics files  |
| *.COS                      | SENTRAN7         | Cosmetic data   |
| SEN.ERR                    | SENTRAN7         | Error log and major absorber information                        |
| SEN.LOG                    | SENTRAN7         | User input log  |

\* Denotes a generic character string

### A.1 Methodology File

Methodology files contain information necessary for setting the parameters in the Edit Module to specific values, including both nominal values and perturbation directives. They provide a convenient means for saving input data for LOWTRAN7 experiments for later recall. Methodology files are generally written and read via the Load/Save Module, with the exception of a special file called *LAST.MTH*. The file, *LAST.MTH*, is saved after every completed editing session (*i.e.*, an editing session in which the user does not proceed to the Main Menu via the END command) and every compilation. This file is loaded every time that SENTRAN7 is started. Since SENTRAN7 extracts vital information from this file, the user is cautioned

against tampering with it in any way. Methodology files have default extensions of *.MTH*.

## **A.2 Input File**

Input files are files containing the LOWTRAN7 or MODTRAN input parameters. Input files are generated by SENTRAN7's Compile Module. They are given the default extension of *.JNP*.

## **A.3 Model Atmosphere Data File**

Model atmosphere data files have *.PRO* default extensions and represent the Card 2C series in LOWTRAN7. Data in this input stream include layer-by-layer profiles of temperature, water vapor, trace gases and aerosol extinction. Details about variable definitions and record formats can be found in the manual for LOWTRAN7<sup>1</sup>.

Because the Card 2C series usually involves many input records, the *.PRO* files must be created off-line by the user. However, the SENTRAN7 package does include six *.PRO* files which represent the six model atmospheres in LOWTRAN7. Temperature, water vapor and trace gas amounts in these files were taken directly from the LOWTRAN7 databases. The aerosol extinction profiles represent a 23 km surface visibility in the boundary layer and background values in the free troposphere, stratosphere and upper atmosphere.

The *.PRO* files included with the SENTRAN7 package can be used to do sensitivity studies for the standard LOWTRAN7 model atmospheres. To do this, the user must first set the MODEL parameter on Card 1 equal to 0 or 7. When the Edit Module asks for a filename for the Card 2C series, the user then enters 'model1', 'model2', etc. After a filename is specified, the next screen contains a list of input parameters for Card 2C where users can assign their percent perturbations. Additionally, novice users can use the model *.PRO* files as guides to create and debug their own atmosphere profiles. Note that if aerosol extinction profiles are included in a *.PRO* file, they will override the values of other aerosol parameters on Card 2.

## **A.4 Aerosol Extinction Coefficients Data File**

Files with *.AER* extensions represent the Card 2D series in LOWTRAN7. Data in this input stream include conversion factors from equivalent water content to aerosol/cloud extinction coefficient and values of aerosol/cloud extinction, absorption and asymmetry parameter versus wavelength for up to four altitude regions. Details about variable definitions and record formats can be found in the manual for LOWTRAN7.<sup>1</sup>

The *.AER* files must be created off-line by the user because the Card 2D series typically involves many input records. However, the SENTRAN7 package

does contain a file named *SAMPLE.AER* which can be used by novice users as a guide to create and debug their own aerosol files. The file, *SAMPLE.AER*, contains wavelength scaling factors for standard aerosols in four altitude regions: (1) rural aerosol at 70% humidity in the boundary layer; (2) tropospheric aerosol at 70% humidity in the free troposphere; (3) background stratospheric aerosol for the stratosphere; and (4) meteoric dust in the upper atmosphere.

The *SAMPLE.AER* file with the SENTRAN7 package can be used to do sensitivity studies for aerosol and cloud scattering as a function of wavelength. To do this, the user must first either set the IHAZE parameter on Card 2 equal to 7 or the ICLD parameter on Card 2 equal to 11. When the Edit Module asks for a filename for the Card 2D series, the user can enter 'sample' or the name of another *.AER* file that they have created. After a filename is specified, the next screen contains a list of input parameters for Card 2D where users can assign their percent perturbations. Note that the Edit Module will scan the contents of the input *.AER* file and only display input parameters for the altitude regions where data are provided.

#### **A.5 Aerosol Phase Functions Data File**

Files with *.PHS* extensions represent the Card 3B series in LOWTRAN7. Data in this input stream are phase functions for aerosol scattering. Details about variable definitions and record formats can be found in the manual for LOWTRAN7.<sup>1</sup>

Because the Card 3B series usually involves many input records, the *.PHS* files must be created off-line by the user. However, the SENTRAN7 package does include a file called *SAMPLE.PHS* which can be used by novice users as a guide to create and debug their own phase function files. For reference, the *SAMPLE.PHS* file contains the phase function of a rural aerosol at 70% humidity and at a wavelength of 0.55  $\mu\text{m}$ .

The *SAMPLE.PHS* file with the SENTRAN7 package can be used as part of sensitivity studies for aerosol and cloud scattering. To do this, the user must first set the IPH parameter on Card 3A1 equal to 2. When the Edit Module asks for a filename for the Card 3B series, the user can type 'sample' or the name of another *.PHS* file that they have created. The Edit Module will read the input *.PHS* file, and the phase function will be included in the LOWTRAN7 input cards. However, the current version of SENTRAN7 does not allow users to perturb values in the *.PHS* file.

## A.6 Output Files

The output files, *tape7* and *tape8*, contain LOWTRAN7 or MODTRAN generated data. The information in these two files are copied to the files, *TAPE7.OUT* and *TAPE8.OUT*, respectively, in a format which SENSTRAN7 can use to extract data for graphical analysis. The contents of these files depend on the values of IEMSCT, IMULT and NOPRT on Card 1. Details about the contents of these output files and record formats can be found in the manual for LOWTRAN7.<sup>1</sup>

## A.7 3-D Files

Three dimensional files are files in raw  $x, y, z$  format.  $Z$  must be a single valued function of  $x$  and  $y$ , while  $x$  and  $y$  must form a semi-regular mesh. That is, the  $(x,y)$  data should form a rectangular grid with a  $z$  value present for every possible  $(x,y)$  combination, but the spacing of the  $x$  and  $y$  points need not be uniform. These files can be written to disk from within the G&A Module of SENSTRAN7. It is worth noting that SENSTRAN7 can read any file in  $x, y, z$  format which conforms to the specifications above. Thus SENSTRAN7's graphing and analysis capabilities are not limited to LOWTRAN7 and MODTRAN data. Another fact worth noting is that 3D files are free of cosmetic data, and are easily exported to more powerful graphics and analysis systems.

## A.8 Graphics File

Graphics files consist of special escape sequences and character data, that are interpreted by Tektronix 4010/4014 compatible devices in order to generate hard copy output of SENSTRAN7 plots. These files are given a default extension of *.TEK*. A wide variety of devices can interpret TEK files, either by design or via special translating programs. Devices supported include video terminals, laser printers, thermal plotters, pen plotters and dot matrix printers. Thus TEK files offer a convenient means of storing and exchanging graphical representations of data.

## A.9 Cosmetic File

Cosmetic files contain "cosmetic" information for 3D files. These cosmetic files are actually screendumps of the G&A command screen, providing information on the data source file, any numerical manipulations which have been performed, the most recent raw  $x, y, z$  file (*\*.3D*) generated, if any, and the most recent graphics file (*\*.TEK*) generated, among other pieces of information.

## A.10 SEN.ERR File

The *SEN.ERR* file is devoted to debugging and temporary storage of information on major absorbers. If the user compiles an input file with the */ERROR* option, SENSTRAN7 writes all compile time errors to *SEN.ERR* along with the names

of major absorbing species and their intervals of activity in the current spectral interval.

### **A.11 *SEN.LOG* File**

The *SEN.LOG* file is a product of SENTRAN7's logging function. This function permits the user to maintain a terse log of his/her SENTRAN7 sessions. SENTRAN7 automatically adds comments, which aid in determining the logical flow that was taken through the program. The user can replace these automatic comments with comments of his/her own. Comments consist of all text within the input string following an apostrophe. For example in the string, **edit 'invoke editor function**, "invoke editor function" is a comment and will be ignored by the program.

Using a verbose style in entering commands will also enhance readability of *SEN.LOG* files. For example the following commands, when typed at the main menu will yield identical results:

```
3 test/m/e  
compile test.inp /mesh/error
```

Clearly, the second style is much more readable, and is the preferred style when developing a *SEN.LOG* file. These tools are indispensable for developing and debugging input files for batch submissions of SENTRAN7.

### **A.12 Help File**

Another file included with the SENTRAN7 package is a help file, *SENTRAN.HLP*. SENTRAN7 uses this file internally in order to generate its help screens. The user is cautioned against tampering with this help file.

## Appendix B

### Code Changes to LOWTRAN7 and MODTRAN

As noted in Section 3.3, LOWTRAN7 and MODTRAN have been modified slightly in order to run with SENTRAN7. These changes have already been made in the LOWTRAN7 and MODTRAN source codes provided with this distribution (*lowtran7.for* and *modtran.for*, respectively). The changes made are outlined here only for reference.

Figure B-1 shows the changes made to the subroutine TRANS in *lowtran7.for*. Line numbers 8020-8060 and 8180-8210 have been commented out. These lines are indicated with a 'c!' comment symbol in Figure B-1.

Figure B-2 shows the changes made to the subroutine TRANS in *modtran.for*. Line numbers 7350-7390 and 7530-7570 have been commented out. These lines are indicated with a 'c!' comment symbol in Figure B-2. In addition, because the input structure for MODTRAN is slightly different from LOWTRAN7, the subroutines BMDATA and DRIVER in *modtran.for* were modified slightly so that MODTRAN could be run from SENTRAN7. The changes made to subroutines BMDATA and DRIVER are shown in Figures B-3 and B-4, respectively. In the subroutine BMDATA, lines of code have been added and/or modified between line numbers 270 and 290. In the subroutine DRIVER, lines of code have been added and/or modified between line numbers 1090 and 1120 and between line numbers 3780 and 3800.

## SUBROUTINE TRANS

|         |  |          |
|---------|--|----------|
| C       |  | TRA 7850 |
| C       | FOR NO MULTIPLE SCATTERING, CALCULATE BLACK BODY FUNCTION, | TRA 7860 |
| C       | AS WELL AS RADIANCE ADDING FOR THERMAL                     | TRA 7870 |
| C       |  | TRA 7880 |
|         | BBIK=BBFN(TBBIY(IK),V)                                     | TRA 7890 |
| C       | TLNEW=(TX(9)*TX(10))/(TX(7)*TX(6))                         | TRA 7900 |
| C       | TSNEW=(TX(7)*TX(6))/TX(10)                                 | TRA 7910 |
|         | TLNEW= TX(9)   | TRA 7920 |
|         | DTAU=TLOLD-TLNEW   | TRA 7930 |
|         | IF(IMULT.EQ.1) DTAU = TOTAL - TX(9)                        | TRA 7940 |
|         | TOTAL = TX(9)  | TRA 7950 |
|         | IF(DTAU.LE.0.) DTAU=0.                                     | TRA 7960 |
|         | IF(IMULT .EQ. 0) THEN                                      | TRA 7970 |
|         | IF(NOPRNT. EQ. -1) THEN                                    | TRA 7980 |
|         | WRITE(IPR1,1210) V,AHT(IK),AHT(IK+1),BBIK,DTAU,TLNEW       | TRA 7990 |
| 1210    | FORMAT(F10.0,2F7.2,1P2E12.5,0PF12.9)                       | TRA 8000 |
|         | ENDIF  | TRA 8010 |
| C       | >>>> CODE MODIFIED BY SPARTA FOR SENTRAN7 <<<<             |          |
| c!      | IF (DTAU.LT.1.0E-5.AND.TLNEW.LT.1.0E-5) THEN               | TRA 8020 |
| c!      | IF(NOPRNT. EQ. -1) WRITE(IPR1,1220)                        | TRA 8030 |
| c! 1220 | FORMAT('      -999.',T63,' DTAU  EXIT LOOP ')              | TRA 8040 |
| c!      | GO TO 220  | TRA 8050 |
| c!      | ENDIF  | TRA 8060 |
| C       | >>>>            END MODIFICATIONS                    <<<<  |          |
|         | SUMV=SUMV+BBIK*DTAU  | TRA 8070 |
| C       | RADIANCE / CONSERVATIVE SCATTERING                         | TRA 8080 |
|         | ELSE   | TRA 8090 |
|         | IF(INIT.EQ.0) GO TO 210                                    | TRA 8100 |
|         | N1 = ML - IMAP(IK) + IOFF                                  | TRA 8110 |
|         | IF(N1.GE.ML ) N1 = ML - 1                                  | TRA*8122 |
|         | IF(NOPRNT. EQ. -1) THEN                                    | TRA 8130 |
|         | N = N1 + 1   | TRA 8140 |
|         | WRITE(IPR1,1230) V,AHT(IK+1),UMB(N),UMBS(N),DMB(N),        | TRA 8150 |
| X       | DMBS(N),SUM+TX(9),TX(9)                                    | TRA 8160 |
|         | ENDIF  | TRA 8170 |
| C       | >>>> CODE MODIFIED BY SPARTA FOR SENTRAN7 <<<<             |          |
| c!      | IF (DTAU.LT.1.0E-5.AND.TX(9).LT.1.0E-5) THEN               | TRA 8180 |
| c!      | IF(NOPRNT. EQ. -1) WRITE(IPR1,1220)                        | TRA 8190 |
| c!      | GO TO 220  | TRA 8200 |
| c!      | ENDIF  | TRA 8210 |
| C       | >>>>            END MODIFICATIONS                    <<<<  |          |

Figure B-1. Code Changes to the Subroutine TRANS in LOWTRAN7 For Use with SENTRAN7

## SUBROUTINE TRANS

|    |   |          |
|----|---|----------|
| C  |   | TRA 7200 |
| C  | FOR NO MULTIPLE SCATTERING, CALCULATE BLACK BODY FUNCTION,  | TRA 7210 |
| C  | AS WELL AS RADIANCE ADDING FOR THERMAL                      | TRA 7220 |
| C  |   | TRA 7230 |
|    | BBIK=BBFN(TBBY(IKOFF),V)                                    | TRA 7240 |
|    | TLNEW=TX(9)   | TRA 7250 |
|    | DTAU=TLOLD-TLNEW  | TRA 7260 |
|    | IF(IMULT.EQ.1)DTAU=TOTAL-TX(9)                              | TRA 7270 |
|    | TOTAL=TX(9)   | TRA 7280 |
|    | IF(DTAU.LE.0.)DTAU=0.                                       | TRA 7290 |
|    | IF(IMULT.EQ.0)THEN  | TRA 7300 |
|    | IF(NOPRNT.EQ.-1)THEN  | TRA 7310 |
|    | WRITE(IPR1,'(F10.0,2F7.2,1P2E12.5,OPF12.9)')                | TRA 7320 |
|    | 1            V,AHT(IK),AHT(IK+1),BBIK,DTAU,TLNEW            | TRA 7330 |
|    | ENDIF   | TRA 7340 |
| C  | >>>> CODE MODIFIED BY SPARTA FOR SENTRAN7 <<<<              |          |
| c! | IF(DTAU.LT.1.E-5 .AND. TLNEW.LT.1.E-5)THEN                  | TRA 7350 |
| c! | IF(NOPRNT.EQ.-1)  | TRA 7360 |
| c! | 1        WRITE(IPR1,'(5X,5H-999.,T65,16HDTAU EXIT LOOP)')   | TRA 7370 |
| c! | GOTO200   | TRA 7380 |
| c! | ENDIF   | TRA 7390 |
| C  | >>>> END MODIFICATIONS <<<<                                 |          |
|    | SUMV=SUMV+BBIK*DTAU   | TRA 7400 |
| C  |   | TRA 7410 |
| C  | RADIANCE / CONSERVATIVE SCATTERING                          | TRA 7420 |
| C  |   | TRA 7430 |
|    | ELSE  | TRA 7440 |
|    | IF(INIT.EQ.0)GOTO190  | TRA 7450 |
|    | N1=ML-IMAP(IK)+IOFF   | TRA 7460 |
| C  | ***** ERRATA JUNE 21 89 NEXT CARD                           | TRA+7465 |
| CC | IF(N1.GE.ML)GOTO190   | TRA+7470 |
|    | IF(N1.GE.ML)N1 = ML - 1                                     | TRA+7472 |
| C  | ***** END ERRATA  | TRA+7474 |
|    | IF(NOPRNT.EQ.-1)THEN  | TRA 7480 |
|    | N=N1+1  | TRA 7490 |
|    | WRITE(IPR1,'(F10.0,F7.2,1P5E12.5,OPF10.5)')V,AHT(IK+1)      | TRA 7500 |
|    | 1            ,UMB(N),UMBS(N),DMB(N),DMBS(N),SUM+TX(9),TX(9) | TRA 7510 |
|    | ENDIF   | TRA 7520 |
| C  | >>>> CODE MODIFIED BY SPARTA FOR SENTRAN7 <<<<              |          |
| c! | IF(DTAU.LT.1.E-5 .AND. TX(9).LT.1.E-5)THEN                  | TRA 7530 |
| c! | IF(NOPRNT.EQ.-1)  | TRA 7540 |
| c! | 1        WRITE(IPR1,'(5X,5H-999.,T65,16HDTAU EXIT LOOP)')   | TRA 7550 |
| c! | GOTO200   | TRA 7560 |
| c! | ENDIF   | TRA 7570 |
| C  | >>>> END MODIFICATIONS <<<<                                 |          |

Figure B-2. Code Changes to the Subroutine TRANS in MODTRAN For Use with SENTRAN7

## SUBROUTINE BMDATA

|   |  |          |
|---|--|----------|
| C |  | BMD 270  |
| C | >>>> CODE MODIFIED BY SPARTA FOR SENTRAN7 <<<<       |          |
|   | CHARACTER*80 DIRUF                                   |          |
|   | OPEN(UNIT=60,FILE='MODTRAN.RUN',STATUS='OLD')        |          |
|   | READ(60,'(L1)')MODTRN                                |          |
|   | READ(60,'(A80)')DIRUF                                |          |
|   | CLOSE(UNIT=60)                                       |          |
|   | ITB = 9  | XXX      |
|   | OPEN(ITB,FILE=DIRUF,STATUS='OLD',FORM='UNFORMATTED') | BMDXXX80 |
| C | >>>> END MODIFICATIONS <<<<                          |          |
|   | 10 REWIND(ITB)                                       | BMD 290  |

Figure B-3. Code Changes to the Subroutine BMDATA in MODTRAN For Use with SENTRAN7

## SUBROUTINE DRIVER

|   |  |          |
|---|--|----------|
| C | 1 M4,M5,M6,MDEF,IM,NOPRT,TBOUND,SALB                         | DRV 1090 |
| C | >>>> CODE MODIFIED BY SPARTA FOR SENTRAN7 <<<<               |          |
|   | OPEN(UNIT=60,FILE='MODTRAN.RUN',STATUS='OLD')                |          |
|   | READ(60,'(L1)')MODTRN  |          |
|   | CLOSE(UNIT=60)   |          |
|   | READ(IRD,'(I5,12I5,F8.3,F7.2)')MODEL,ITYPE,IEMSCT,           | DRV 1100 |
|   | 1 IMULT,M1,M2,M3,M4,M5,M6,MDEF,IM,NOPRT,TBOUND,SALB          | DRV 1110 |
| C | >>>> END MODIFICATIONS <<<<                                  |          |
|   | 1110 FORMAT(13I5,F8.3,F7.2)                                  | DRV 1120 |
|   | C1401 FORMAT('O CARD 4 *****',3F10.3)                        | DRV 3780 |
| C | >>>> MODIFICATIONS BY SPARTA FOR SENTRAN7 <<<<               |          |
|   | READ(IRD,'(3F10.3,I10)')RV1,RV2,RDV,IFWHM                    | DRV 3790 |
|   | IV1=INT(RV1)   |          |
|   | IV2=INT(RV2)   |          |
|   | IDV=INT(RDV)   |          |
| C | >>>> END MODIFICATIONS <<<<                                  |          |
|   | 401 WRITE(IPR,'(15H O CARD 4 *****',4I10)')IV1,IV2,IDV,IFWHM | DRV 3800 |

Figure B-4. Code Changes to the Subroutine DRIVER in MODTRAN For Use with SENTRAN7

## **Appendix C**

### **Quick Reference Guide For SENTRAN7**

There are many commands and files associated with the SENTRAN7 package. Therefore, this appendix serves as a quick reference guide to help users become familiar with operating SENTRAN7. Effectively, the guide is a collection of tables that were previously introduced in the main text. The material is not formally organized; rather, it is designed to give users quick and concise information about the commands and features of SENTRAN7. Table C-1 lists the cursor control commands used in the Edit Module. Table C-2 lists the perturbation commands used in the Edit Module. Table C-3 lists examples of perturbation commands that can be used. Table C-4 lists the allowable compiler commands as typed from the Main Menu and Table C-5 lists examples of these compiler commands as they would be typed from the Main Menu.

Table C-6 to C-9 relate the Graph and Analyze Module. Table C-6 provides the list of the types of plots that are available in the Graph and Analyze Module, while Table C-7 lists the commands that are used to perform numerical analysis in the Graph and Analyze Module. Table C-8 lists the plotting commands used while in the Graph and Analyze Module and Table C-9 lists the commands used for input/output and control operations in the in the Graph and Analyze Module.

Tables C-10 and C-11 relate to the files used and provided with SENTRAN7. Table C-10 lists the default file names and extensions used with SENTRAN7 and Table C-11 is a checklist of the files provided with the SENTRAN7 package.

Table C-1. List of Cursor Control Commands in the Edit Module of SENTRAN7

| COMMAND  | ACTION   |
|----------|--|
| UP $n^1$ | Move cursor up $n$ lines                       |
| DN $n$   | Move cursor down $n$ lines                     |
| PU       | Move to previous major <sup>2</sup> card image |
| PD       | Move to next major card image                  |
| END      | End editing session, goto main menu            |

<sup>1</sup>  $n$  is optional; its absence means  $n = 1$

<sup>2</sup> Major cards are Card 1, 2, 3, 4

Table C-2. List of Perturbation Command Syntaxes in the Edit Module

| TYPE OF PERTURBATION | SYNTAX FORMAT   |
|----------------------|---|
| % <sup>1</sup>       | <i>nominal value %value</i>   |
| +/-                  | <i>nominal value +/- value</i>  |
| Iteration            | <i>nominal value [start]<sup>2</sup> TO final [STEP <math>n</math>]</i> |
| List                 | <i>nominal value value2 value3 ...</i>                                  |
| Use Previous         | <i>nominal value *</i>  |

<sup>1</sup> On Card 2C and 2D, no nominal value allowed with percent perturbation

<sup>2</sup> Terms in "[ ]" are optional

Table C-3. Examples of Perturbation Directives

| SAMPLE PARAMETER | PERTUBATION DIRECTIVE | SEQUENCE PRODUCED |
|------------------|-----------------------|-------------------|
| H1               | 5.0 %20               | 4.0, 5.0, 6.0     |
| H2               | 8.0 +/- 2             | 6.0, 8.0, 10.0    |
| ANGLE            | 45.0 TO 47            | 45.0, 46.0, 47.0  |
| RANGE            | 10.0 TO 20 STEP 5     | 10.0, 15.0, 20.0  |
| VIS              | 5.0 0 TO 10 STEP 5    | 0.0, 5.0, 10.0    |
| MODEL            | 4 3 6                 | 4, 3, 6           |

Table C-4. Allowable Compiler Commands As Typed From the Main Menu

|   |
|---|
| <b>compile</b> [ <i>card image name</i> ] [/MESH /NOMESH /ERROR]<br>or<br><b>3</b> [ <i>carriage return</i> ] [ <i>card image name</i> ] [/MESH /NOMESH /ERROR] |
|---|

**/MESH** Generates All Possible Combinations of Perturbed Input Parameters

**/NOMESH** Perturbs One Parameter at a Time, Holding All Others Fixed

**/ERROR** Creates *SEN.ERR* Containing Compile Errors and List of Active Molecular Absorbers

Table C-5. Examples of Compiler Commands as Typed From the Main Menu

| COMMAND                             | EFFECT   |
|-------------------------------------|--|
| <b>compile test /m /e</b>           | Compiles input file named <i>TEST.JNP</i> as MESH and generates the error file <i>SEN.ERR</i>  |
| <b>3</b> <RETURN><br><b>test /n</b> | Compiles input file named <i>TEST.JNP</i> as NOMESH with no error file   |
| <b>com test.wow</b>                 | Compiles input file named <i>TEST.WOW</i> using last mode (MESH or NOMESH) as default, no error file generated   |
| <b>c test.dumb /m /n /e</b>         | Compiles input file named <i>TEST.DUMB</i> as NOMESH demonstrating that MESH and NOMESH are exclusive, with NOMESH taking precedence. An error file is created |

Table C-6. Type of Plots Available in the Graph and Analyze Module

| PLOT TYPE                  | SPECIFIC PLOTS   | PARAMETERS                              |
|----------------------------|--|---|
| Raw $x, y, z$              |  |   |
| Transmittance              | Total Transmittance<br>Log of Total Transmittance<br>Uniform Mixed Gases<br>Trace Gases<br>Molecular Scattering<br>H <sub>2</sub> O<br>H <sub>2</sub> O Continuum<br>Ozone (O <sub>3</sub> )<br>N <sub>2</sub> Continuum<br>Aerosol and Hydrometeor<br>CO <sub>2</sub><br>CO<br>CH <sub>4</sub><br>N <sub>2</sub> O<br>O <sub>2</sub><br>NH <sub>3</sub><br>NO<br>NO <sub>2</sub><br>SO <sub>2</sub><br>HNO <sub>3</sub><br>Aerosol and Hydrometeor Absorption | IEMSCT = 0<br>IMULT = 0                 |
| Atmospheric Radiance       | Total Transmittance<br>Radiance<br>Log of Total Transmittance  | IEMSCT = 1<br>IMULT = 0,1               |
| Differential Transmittance | DTAU<br>DTAU / Layer Thickness   | IEMSCT = 1,2<br>IMULT = 0<br>NOPRT = -1 |
| Black Body Function        | DTAU * Black Body Function<br>(DTAU * Black Body Function) /<br>Layer Thickness  | IEMSCT = 1,2<br>IMULT = 0<br>NOPRT = -1 |
| Fluxes/Irradiance          | Upward Total FLUX<br>Upward Solar FLUX<br>Downward Total FLUX<br>Downward Solar FLUX<br>Direct Solar Irradiance  | IEMSCT = 1,2<br>IMULT = 1<br>NOPRT = -1 |
| Solar/Lunar Radiance       | Total Transmittance<br>Radiance<br>Path Scattered<br>Single Scattered<br>Total Ground Reflectance<br>Direct Reflected<br>Total Radiance<br>Log of Total Transmittance  | IEMSCT = 2<br>IMULT = 0,1               |
| Direct Solar Radiance      | Total Transmittance<br>Transmitted Solar<br>Incident Solar<br>Log of Total Transmittance   | IEMSCT = 3<br>IMULT = 0                 |

Table C-7. List of Numerical Commands in Graph and Analyze Module

| COMMAND        | ARGUMENTS | DESCRIPTION  |
|----------------|-----------|--|
| <b>A2T</b>     | NONE      | Optical Depth to Transmittance Transformation<br>Transform z axis according to $z=\exp(-z)$  |
| <b>DX</b>      | NONE      | Compute partial derivative of the data set<br>with respect to the x axis                     |
| <b>DY</b>      | NONE      | Compute partial derivative of the data set<br>with respect to the y axis                     |
| <b>DDX</b>     | NONE      | Compute second partial derivative of the data set<br>with respect to the x axis              |
| <b>DDY</b>     | NONE      | Compute second partial derivative of the data set<br>with respect to the y axis              |
| <b>DYDX</b>    | NONE      | Compute cross derivative of the data set<br>with respect to the y axis and then the x axis   |
| <b>DXDY</b>    | NONE      | Compute cross derivative of the data set<br>with respect to the x axis and then the y axis   |
| <b>LOG</b>     | [X][Y][Z] | Transform all coordinates of the named axis<br>to their log values (Example: 'log x')        |
| <b>MAXIMUM</b> | NONE      | Write the maximal z values on the screen along<br>with their x,y coordinates                 |
| <b>MEAN</b>    | NONE      | Compute and displays the mean z axis value   |
| <b>MINIMUM</b> | NONE      | Write the minimal z values on the screen along<br>with their x,y coordinates                 |
| <b>NOSORT</b>  | [X][Y]    | Suppress SENTRAN's tendency to sort data into<br>increasing order (Example: 'nosort x')      |
| <b>SWAP</b>    | NONE      | Swap the x and y axes  |
| <b>T2A</b>     | NONE      | Transmittance to Optical Depth Transformation<br>Transform z axis according to $z=\log(1/z)$ |

Table C-8. List of Plotting Commands in Graph and Analyze Module

| COMMAND       | ARGUMENTS          | DESCRIPTION   |
|---------------|--------------------|---|
| <b>PLOT</b>   | [file name][VT240] | Plot the data set to the specified file name (*.TEK) or to the screen [VT240 argument] (NOTE: Both arguments may be specified and the program will plot the data to the file and to the screen) |
| <b>TITLE</b>  | [plot title]       | Treat all following text as title for next plot, and center this text at the top of the plot  |
| <b>XLABEL</b> | [x axis Label]     | Treat all following text as the x axis label (up to 30 characters)  |
| <b>YLABEL</b> | [y axis Label]     | Treat all following text as the y axis label (up to 30 characters)  |
| <b>ZLABEL</b> | [z axis Label]     | Treat all following text as the z axis label (up to 30 characters)  |

Table C-9. List of I/O and Control Commands in Graph and Analyze Module

| COMMAND         | ARGUMENTS           | DESCRIPTION   |
|-----------------|---------------------|---|
| <b>WRITE</b>    | [x, y, z file name] | Write the current data set to the named file as raw x, y, z data (default extension is .3D)   |
| <b>COSMETIC</b> | [file name]         | Screendump of current G&A command screen to the named file  |
| <b>NEW</b>      | NONE                | Restart the G&A Module  |
| <b>EXIT</b>     | NONE                | Exit the G&A Module, return to Main Menu  |
| <b>HELP</b>     | [command name]      | Accesses the G&A on-line help utility. If a valid G&A command is supplied as an argument, then help on the selected command is provided. If no argument is supplied, then a special introductory HELP screen is presented, listing all of the G&A commands. |
| <b>REFRESH</b>  | NONE                | Redraw the G&A command screen   |

Table C-10. Default File Names Associated With SENTRAN7

| FILE NAME<br>AND EXTENSION | ORIGIN           | CONTENTS  |
|----------------------------|------------------|---|
| <i>*.MTH</i>               | SENTRAN7         | Methodology files   |
| <i>*.JNP</i>               | SENTRAN7         | LOWTRAN7/MODTRAN input files                              |
| <i>*.PRO</i>               | User             | Model atmosphere data<br>(i.e., Card 2C series)           |
| <i>*.AER</i>               | User             | Aerosol extinction coefficients<br>(i.e., Card 2D series) |
| <i>*.PHS</i>               | User             | Aerosol phase functions<br>(i.e., Card 3B series)         |
| <i>*.OUT</i>               | LOWTRAN7/MODTRAN | Output data used for plotting                             |
| <i>*.3D</i>                | User/SENTRAN7    | Raw <i>x, y, z</i> data                                   |
| <i>*.TEK</i>               | SENTRAN7         | Tektronix graphics files                                  |
| <i>*.COS</i>               | SENTRAN7         | Cosmetic data   |
| <i>SEN.ERR</i>             | SENTRAN7         | Error log and major absorber<br>information               |
| <i>SEN.LOG</i>             | SENTRAN7         | User input log  |

\* is a wildcard indicating arbitrary text

Table C-11. File Checklist for SENTRAN7

| FILE NAME           | CONTENTS  |
|---------------------|---|
| <i>senmain.for</i>  | Source code for SENTRAN7 (main program only)  |
| <i>sensubs.for</i>  | Source code for SENTRAN7 (other routines)   |
| <i>sennew.for</i>   | Source code for SENTRAN7 (routines created by SPARTA)   |
| <i>senvms.for</i>   | Source code for SENTRAN7 (VAX computer systems only)  |
| <i>senunix.f</i>    | Source code for SENTRAN7 (UNIX computer systems only)   |
| <i>MAJABS.DAT</i>   | Data file defining regions of molecular absorption  |
| <i>DIRECT.ORY</i>   | Configuration file containing directory and name of LOWTRAN7 and MODTRAN executables and the <i>UFTAPE.DAT</i> file. Current directory is assumed when <i>DIRECT.ORY</i> does not exist |
| <i>SENTRAN.HLP</i>  | SENTRAN7 on-line help utility file  |
| <i>MODEL1.PRO</i>   | Tropical atmosphere profile ( <i>i.e.</i> , Card 2C series)   |
| <i>MODEL2.PRO</i>   | Midlatitude summer profile  |
| <i>MODEL3.PRO</i>   | Midlatitude winter profile  |
| <i>MODEL4.PRO</i>   | Subarctic summer profile  |
| <i>MODEL5.PRO</i>   | Subarctic winter profile  |
| <i>MODEL6.PRO</i>   | U.S. standard profile   |
| <i>SAMPLE.AER</i>   | Sample Card 2D series: normalized aerosol extinction versus wavelength for four aerosol regions   |
| <i>SAMPLE.PHS</i>   | Sample Card 3B series: aerosol phase functions for four aerosol regions   |
| <i>DEFAULT.MTH</i>  | Sample methodology file (used in Tutorial #1)   |
| <i>lowtran7.for</i> | Source code for LOWTRAN7  |
| <i>modtran.for</i>  | Source code for MODTRAN   |
| <i>mkbin.for</i>    | Program creates <i>UFTAPE.DAT</i> from <i>BMTAPE.DAT</i>  |
| <i>makefile.com</i> | Command file for compiling and linking SENTRAN7 on VAX/VMS systems. Type '@makefile' to execute   |
| <i>makefile</i>     | Unix command file for compiling and linking SENTRAN7 on SUN systems. Type make to execute   |

## Appendix D

### Flow Chart for the Graph and Analyze Module

As discussed in the report, the SENTRAN 7 Graph and Analyze Module has a structure that imposes graphing restrictions on the user. Figure D-1 outlines the logical flow for selecting the plotting parameters in the Graph and Analyze Module of SENTRAN7.

As noted in the flow chart, there are three basic choices for plotting and each choice has specific options specified. If selected to plot a raw  $x, y, z$  data file, the Graph and Analyze Module will immediately prompt the user for the name of the file. This file is then read in and the command screen is presented to the user for entering commands to manipulate and plot the data set. If the user is plotting differential transmittance, black body functions or fluxes/irradiance, the  $x$  and  $y$  axes are automatically set to layer # and wavenumber, respectively. The user then selects the  $z$  axis parameter to plot and enters a LOWTRAN7 *tape8* type file to be read in. Finally for all other plot types, the user selects the parameters to be plotted on the  $x, y$  and  $z$  axes, according to the flow diagram in Figure D-1. The user is referred to Section 4.2.7 for more information on the Graph and Analyze Module of SENTRAN7.

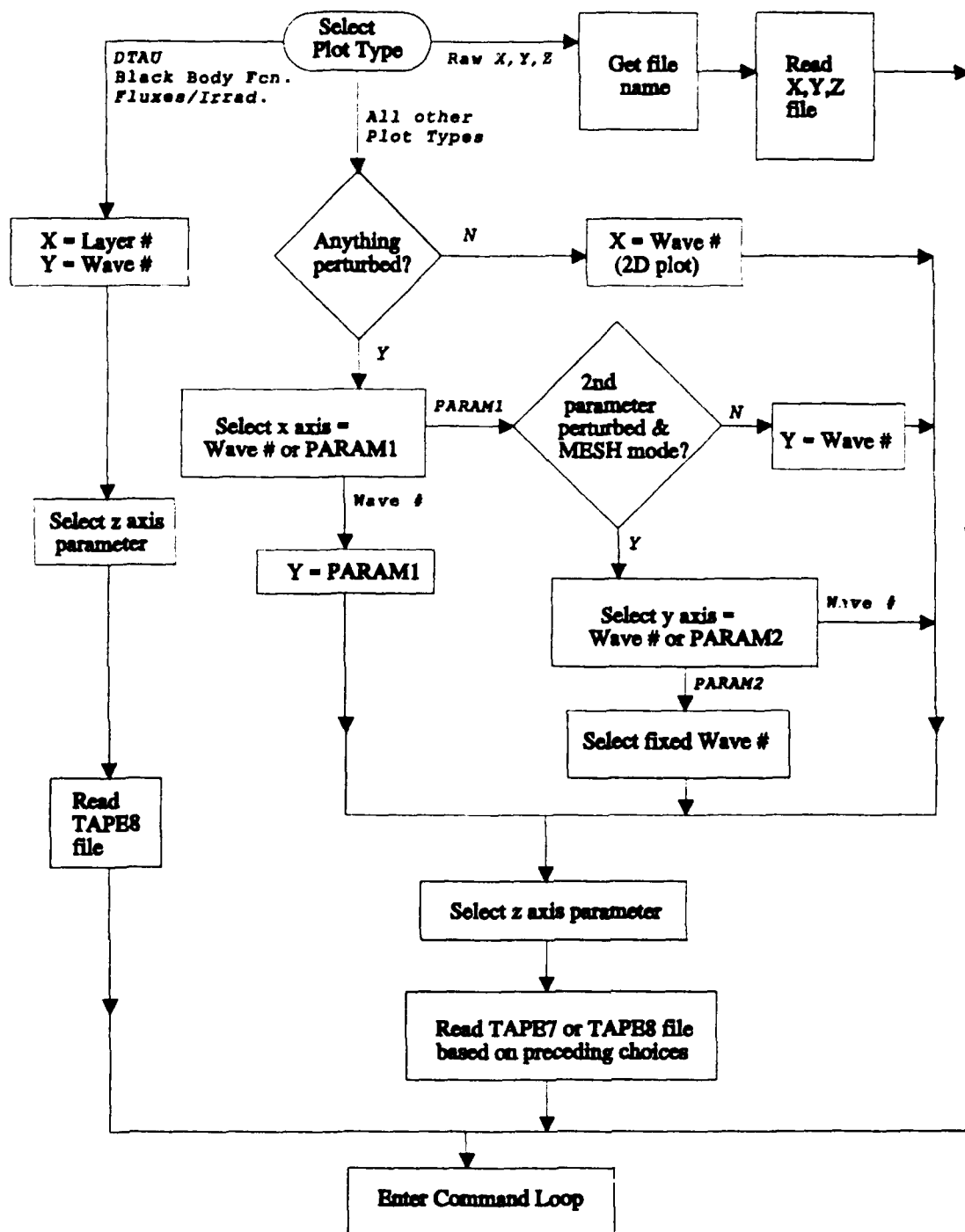

Figure D-1. Simplified Flow Diagram for Selecting Plotting Parameters in the Graph and Analyze Module. PARAM1 and PARAM2 represent the first and second LOWTRAN7 variables perturbed