

2

AD-A251 831



Remote Pilot Program

Supporting the 1991 Galapagos Island Jason Project

Final Report

DTIC
ELECTE
JUN 15 1992
S A D

Prepared by:

**Marquest Group, Inc.
8 Otis Park Drive
Bourne, MA 02532**

March 1992

**This document has been approved
for public release and sale; its
distribution is unlimited.**

Reference: ONR Grant No. N00014-91-J-1348

Prepared for:

**Jason Foundation for Education
550 N. 31st Street, Suite 250
Billings, MT 59101**

92 4 08 037

92-09066



1. Executive Summary

The 1991 field program for the JASON Project was carried out in the Galapagos Islands during November and December. As part of the live broadcast from this remote location, an underwater robot, JASON Jr., was to be linked up via satellite to a Remote Pilot Workstation located at any one of the JASON Museum Network downlink sites. During every one-hour program, a student pilot, selected from the participating sites, would "fly" JASON Jr. while sitting at the Remote Pilot Workstation, experiencing telepresence personally and demonstrating the concept to everyone watching on the network.

Disaster struck on November 21 when the barge carrying JASON Jr. and all the equipment destined for the Galapagos Islands sank. After a tremendous relief effort rallied enough equipment for the Project to continue, the Remote Pilot Program successfully fielded three Workstations which travelled around the Museum Network, providing the telepresence experience to ten sites across North America.

Marquest Group provided the equipment which was fielded in the Galapagos to track and position the underwater robot, as well as the Workstation equipment used in the Museums to control that vehicle remotely. This report details the level of effort required to complete the 1991 Remote Pilot Program in terms of equipment, logistic support and engineering.

Accession For	
NTIS	GRAND
DIC	TRK
Unannounced	
Justification	
By	
Distribution	
Availability	
Dist	AVAIL
A-1	

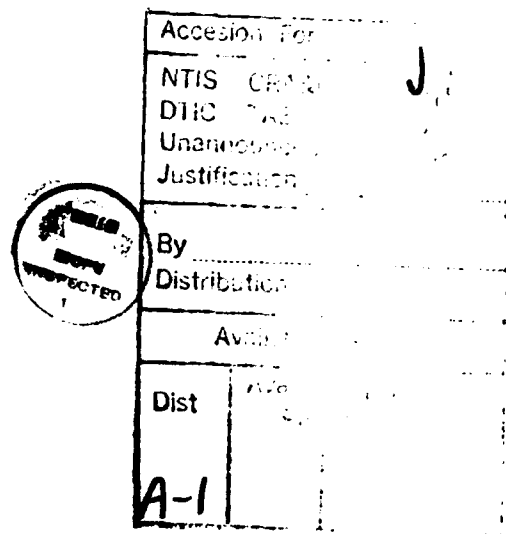

Statement A per telecon Debra Hughes
ONR/Code 11SP
Arlington, VA 22217-5000

NWW 6/11/92

2. Introduction

We know from research that students remember 10% of what they hear and 15% of what they read, but they remember 80% of what they do. If our nation is to attract young students into science, we want their experiences with science to be positive and leave a lasting impression. The JASON Pilot Program has been a high point of each hour program televised during the 1990 and 1991 field programs. Over both years, 110 students have taken over the controls of JASON, and via the technology of telepresence, flown the vehicle at the field site from their control station at a Museum. This is an experience they will never forget. It has also had a significant impact on all the students at the downlink site who were watching them drive.

2.1. Program Plan for 1991

During the 1991 program in the Galapagos Islands, we had planned to deploy JASON, Jr. (J.J.) and use this vehicle as the remotely piloted robot. The plan was to position J.J. in 300 feet of water at the base of a submerged lava flow, in view of a fixed, bottom mounted camera system. This latter system, which had both video and film cameras mounted on a pan & tilt unit, would be prepositioned to capture images of J.J. while it was operating. Then imagery from both points of view, looking at J.J. and the view from J.J., would be available for transmission over the satellite link.

On location in the Galapagos Islands, J.J.'s pilot would use this "flying eyeball" to provide close up views of marine geology and biology in support of the scientific activities. At the end of each one-hour program, a student pilot would be given an opportunity to remotely pilot J.J. from one of the network downlink sites. Once audio and video links are established between the student pilot and the J.J. pilot on location in the islands, the J.J. pilot explains how the controls work. He instructs the student on J.J.'s different functional commands and how they can be integrated to produce fluid motion.

The downlink site where each student is located will uplink a live video image of the student operating the controls. That image is mixed in Atlanta, GA with the live images coming from the Galapagos Islands. Therefore all the downlink sites in the JASON network can participate in the student pilot's experience.

The student pilot is assisted on site by a Marquest Group engineer who travels to the site bringing the Workstation and control system. This hardware is interfaced to the site's downlink facility and checked prior to each

broadcast. Simulation software is used to prepare and train the student pilot just before each one-hour program.

2.2. Remote Control Background

To remotely pilot J.J., an underwater tracking system, SHARPS, is used to locate the exact position and attitude of the vehicle. It provides a precise position fix, accurate to within 1 cm, at a repetition rate of up to 10 Hz. A second computer system running TRACS, a supervisory control system, inputs the position data and puts the robot under full closed-loop, position control. Marquest Group manufactures this tracking and positioning system hardware and software. The local operator's station can program the vehicle to hover, follow pre-programmed tracks or fly on "joystick-auto". In this latter mode the pilot's joystick is used to move a cursor to desired locations, and TRACS flies the vehicle to that spot, i.e. it follows the supervisor. It is this mode which is used at the remote pilot station.

The remote pilot's station uses a computer located at the downlink site which communicates with TRACS via the satellite link. Only low speed, digital data (e.g. 9600 baud) is required to support the operation. This computer runs a version of TRACS which interfaces with the Workstation Hand Box and gives the student pilot full function control, from a location thousands of miles distant. A joystick on the control panel is used to move the cursor indicating desired vehicle trajectory. Another icon indicates the actual vehicle position which "catches up" with the cursor moved by the pilot. In addition, the live video link brings the vehicle's video to the pilot as feedback of the operation.

2.3. Disaster Strikes

On November 21, 1991, the barge carrying J.J. and all the equipment used to support the JASON field program sank approximately 120 miles east of the Galapagos Islands. Only 10 days before the live broadcast would commence, all the satellite transmission, video production and supporting equipment was sitting ruined at 9,000 feet depth. J.J. itself is probably the only thing not destroyed by the seawater and pressure.

Over the next seven days a tremendous effort was undertaken to provide new equipment to successfully carry out the operation. On Thanksgiving Day, a C-130 cargo plane flown by the Ecuadorian Air Force, landed on Baltra Island carrying enough equipment to continue the scientific expedition and live broadcast from the Galapagos Islands.

2.4. Revised Program Plan

Included in this emergency airlift was a new underwater robot to take the place of J.J. and a complete complement of SHARPS and TRACS hardware to enable the Remote Pilot Program to proceed. Benthos, Inc. provided the vehicle, a MiniRover Mk II, which was available from an existing, joint development program sponsored by Marquest and Benthos. The MiniRover had recently been upgraded with the automatic control capability, and now it would be called upon to replace J.J. and provide a platform for the Remote Pilot Program.

The plan now called for the MiniRover to operate from a small boat moored in a deep bay off Baltra Island. This location offered an area of interesting marine observations and was close to the satellite uplink and video production site dubbed "Jasonville". With most of the microwave transmission gear now sitting at the bottom of the ocean, the MiniRover site now had to be linked by cables and land lines to the satellite transmission tent.

Over the course of the 14 day schedule, the MiniRover and TRACS control system were operated continuously for 8-10 hours a day. They provided video observations and Remote Piloting for each one-hour, live broadcast which aired 5 times daily.

The Remote Pilot Program was able to continue as if J.J. were there. The MiniRover was a suitable replacement and the individual programs at the Museum sites proceeded as originally planned.

3. Description of Tasks

Marquest Group was tasked to support the Remote Pilot Program by providing equipment and personnel for operating the automatic control systems which are fielded to the various downlink sites. These sites are located throughout North America, primarily at science museums and academic institutions.

3.1. ROV Workstation

As part of the effort in 1991, a third Workstation Hand Box was provided. Appendix A lists the complete set of hardware deliverable under this task. Figure 1 is a drawing of the Workstation Remote Control Hand Box, Dwg. 800236. The Hand Box is part of the man-machine interface, providing a 5-axis joystick and trackball which the pilot uses to interact with the software. This third system joins two identical systems which are used to support the Remote Pilot effort. Originally intended to be simply a spare, the third system was pressed into service during the broadcast schedule to facilitate travel and shipping.

Additional equipment is required to operate the Remote Pilot Site. The entire complement of equipment required to operate the Remote Pilot Site is tabulated in Appendix B, where the Workstation Hand Box is one item of the total. Primarily, the additional equipment is the computer itself, which interfaces with the Hand Box and runs the software, and a modem, which interfaces the computer to the satellite data link. This equipment was provided on a loan basis during the Galapagos Islands field program as part of Marquest's logistics support.

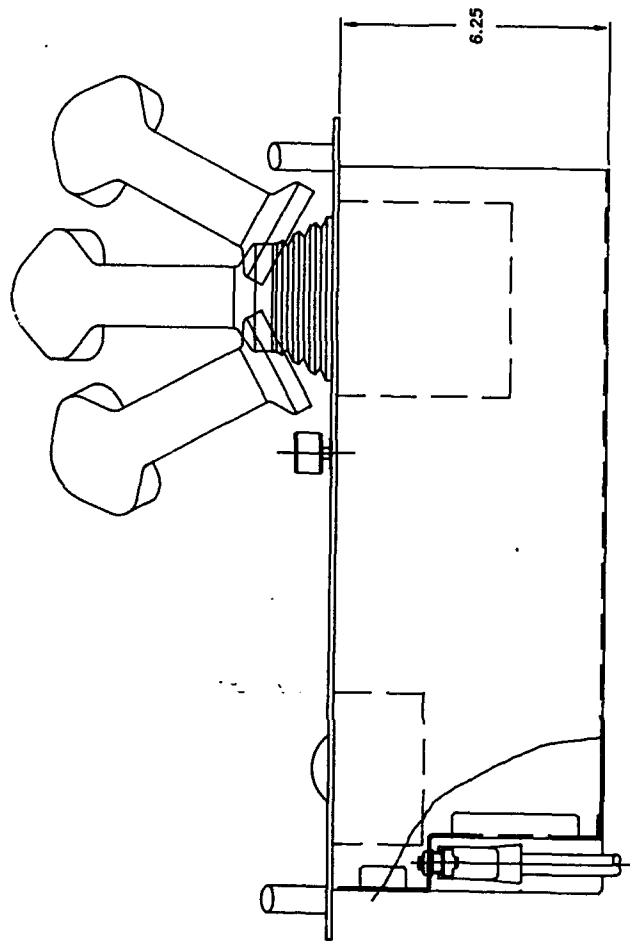
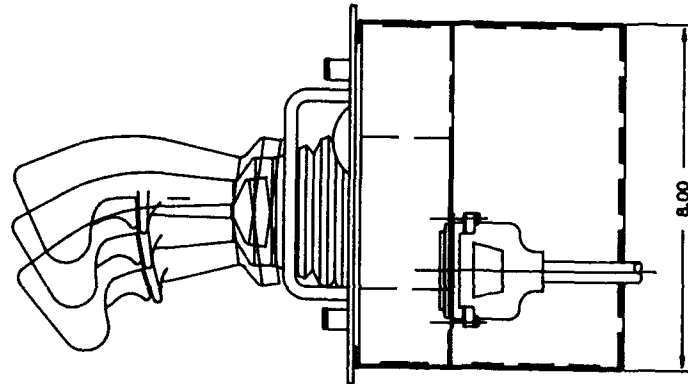
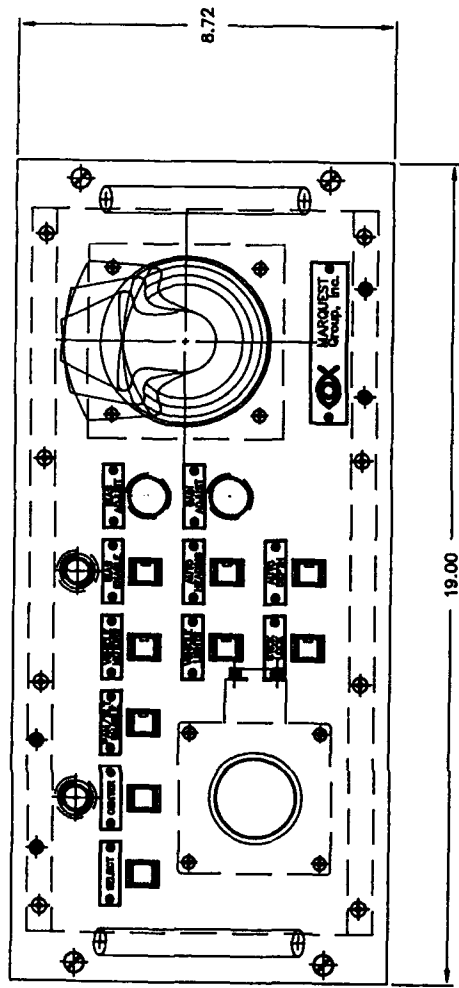

FIGURE 1: WORKSTATION HAND BOX

3.2. Remote Driving Program

During the two weeks of live broadcasts, three engineers travelled to various downlink sites to set up the Workstation hardware and help the students use the equipment. One downlink site was selected to receive a Remote Pilot Workstation every day, and that site supported five student pilots during that day. The next day another site would sponsor a Remote Pilot.

To support this activity, the three engineers travelled throughout the Museum Network, handcarrying the Remote Site equipment. They would arrive at a site the day prior to the designated piloting day to set up the equipment. On the next day they would meet with each student selected to be a pilot and walk them through the operation. Simulation software was used to train the students and allow them to get the feel of the joystick prior to the live broadcast. With considerable video game training available to most students, these young pilots generally are able to assimilate the task quickly.

The engineers were called upon to provide a number of tasks:

1. Interact with Dr. Ballard (at Turner Broadcasting's Studio in Atlanta, GA) over the satellite link and provide a smooth transition between the pilot on site in the Galapagos and the student pilot.
2. Provide technical and troubleshooting support for the equipment.
3. Interface with the Museum personnel to support their Remote Pilot activities, such as assisting with the video uplink services and participate in media coverage.

3.3. Engineering and Logistics Support

Prior to the Galapagos Islands broadcast, a coordinator at Marquest was assigned to assemble and test the three Remote Site Workstations. He also established schedules and itineraries for the engineers who would be travelling. Testing involved setting up a Remote Site at the Marquest facility in Bourne, MA and using standard phone lines to connect with a TRACS system operating at Woods Hole, MA. The software configuration was agreed to and finalized prior to J.J. leaving the U.S. for its trip to the Galapagos Islands.

Of course after the barge sank, all hands involved with the project scrambled to find alternate means to carry on the plan. The MiniRover was expedited from a previous

engagement and rushed to Woods Hole for last minute check out with TRACS and Remote Site Workstation. Once the MiniRover was configured to operate satisfactorily over the phone link, it was shipped to the forwarding point for eventual shipment to the Galapagos.

As mentioned earlier, once the interface was established with the new vehicle, the Remote Pilot Program proceeded as planned.

Appendix C contains the schedule used for the 1991 project.

Appendix D contains a letter sent to the sites which participated in the Remote Pilot Program. Our intent is to follow up on our effort and solicit comments for change, improvement, etc. Responses which we have received will be used to support our efforts in the upcoming JASON Projects.

Appendix A

Workstation Model 62-10
Parts List

Item	Qty	Part No.	Description
1.	1	800236	Telerobotic Remote Hand Box
2.	1	800268	Telerobotic Remote Power Supply
3.	1	235016	Cable, DB-37, M-F, 10 ft. (Inmac 0376-1)
4.	1	235001	Cable, DB-50, M-M, 10 ft. (Inmac 0377-2)
5.	1	235008	Cable, 3 cond., Power Cord, 14 AWG, SJT
6.	1	n/a	Parallel I/O PCB, PIO-24, Metrabyte PC6422
7.	1	n/a	Software, RCS v. 1.60
8.	1	257007	Shipping Case, Telerobotic Hand Box

Appendix B

**JASON Remote Pilot Site
Parts List**

Item	Qty	Part No.	Description
1.	1	62-10	Telerobotic Workstation
2.	1	n/a	US Robotics Courier HST Modem
3.	1	230058	Cable, RG-58/BNC, 10 ft.
4.	1	n/a	Cable, DB-25 Serial (Modem I/F), 10 ft.
5.	1	n/a	Adapter, BNC/RCA Phono, (Radio Shack 278-301)
6.	1	n/a	Adapter, BNC Tee, (Radio Shack 278-111)
7.	1	n/a	Headset, David Clark Model H8730
8.	1	n/a	Computer, 386-25
9.	1	n/a	Video Display PCB, U.S. Video
10.	1	257005	Shipping Case, Computer

Show and Time Zones

	Eastern	Central (Galapogas)	Mountain	Pacific
Show 1	10:00	09:00	08:00	07:00
Show 2	11:30	10:30	09:30	08:30
Show 3	13:00	12:00	11:00	10:00
Show 4	14:30	13:30	12:30	11:30
Show 5	16:00	15:00	14:00	13:00

Friday, November 29, 1991

Originally Scheduled Rehearsal 1:00 PM EST

Science Museum of Charlotte
301 North Tyron Street
Charlotte, NC 28202

Beverly Sanford
Voice: 704.372.6261
FAX: 704.337.2670

Remote Flyer: Stephen F. Mealy/Nathan T. Ulrich

Maritime Center
10 North Street
South Norwalk, CT 06854

Jack Schneider, Director of Programs
Voice: 203.852.0700 ext. 242
FAX: 203.838.5416

Remote Flyer: Dana R. Yoerger

Monday, December 2, 1991

Science Museum of Charlotte
301 North Tyron Street
Charlotte, NC 28202

Beverly Sanford
Voice: 704.372.6261
FAX: 704.337.2670

Remote Flyer: Nathan T. Ulrich

Tuesday, December 3, 1991

Maritime Center
10 North Street
South Norwalk, CT 06854

Jack Schneider, Director of Programs
Voice: 203.852.0700 ext. 242
FAX: 203.838.5416

Remote Flyer: Dana R. Yoerger

Wednesday, December 4, 1991

Ontario Science Center
770 Don Mills Road
Don Mills, Ontario
Canada M3C 1T3

Monica Locher
Voice: 416.429.4100
FAX: 416.429.2934

Remote Flyer: Stephen F. Mealy

Thursday, December 5, 1991

Lehigh University
Grace Hall
Lehigh University
Bethlehem, PA 18015

Dr. Judy Bazler
Voice: 215.758.3238
FAX: 215.758.5423

Remote Flyer: Nathan T. Ulrich

Friday, December 6, 1991

New England Science Center
222 Harrington way
Worcester, MA 01604-1899

Laura Myers
Voice: 508.791.9211

Remote Flyer: Dana R. Yoerger

Monday, December 9, 1991

"Black Tie Evening"

Orange County Marine Institute
The Pavilion Office
P.O. Box 68
Dana Point, CA 92629

Stan Cummings
Voice: 714.248.0503
FAX: 714.248.5557
Barbara Plechner, Beckman Institute 714.721.2200

Remote Flyer: Nathan T. Ulrich

Tuesday, December 10, 1991

"Black Tie Evening"

Mote Marine Laboratory
1600 Thomson Parkway
Sarasota, FL 34236

Kumar Mahadevan
Voice: 813.388.4441
FAX: 813.388.4312

Remote Flyer: Dana R. Yoerger

Wednesday, December 11, 1991

Harbor Branch Oceanographic Institute
5600 Old Dixie Highway
Fort Pierce, FL 34946
Tom Fritz

Voice: 407.465.2400 ext. 206
FAX: 407.468.0757

Remote Flyer: Stephen F. Mealy

Thursday, December 12, 1991

National Geographic Society
Grosvenor Auditorium
1145 17th Street, N. W.
Washington, D.C. 20036
Andy Van Duym, Director of Program Development

Voice: 202.775.6145
FAX: 202.775.6141

Remote Flyer: Nathan T. Ulrich

JASON Project RCS Program

Page 17 of 17

Friday, December 13, 1991

The Science Place
Fair Park, Box 11158
Dallas, TX 75223

Libby Lewis

Voice: 214.428.7200

FAX: 214.428.2033

Remote Flyer: Dana R. Yoerger



MARQUEST
GROUP

APPENDIX D

FOLLOW-UP LETTER / SOLICITATION

December 16, 1991

Name
Address 1
Address 2
Address 3

Dear Name:

I have arrived back safely with all gear intact to be greeted once again with winter here on Cape Cod. Considering the handicap we started with, I am pleased with the Student Flying part of the Jason Project. Of forty scheduled flights with the students, we were able to make all but one. I visited three of the ten sites which participated in the flying; Harbor Branch, Charlotte's Discovery Place and Ontario's Science Center. After watching each of the center's presentations of the Project and having participated in each of their presentations I'd like to gather some feedback from you and the other seven sites which participated in this year's student flying program.

If there are areas which you felt could have been better or which struck you as being very well done concerning the flying portion of the presentation, I'd like to hear your comments. I have several observations of the three sites I visited. I have talked briefly with my counterparts and they have several concerning those they visited. I'd like to complete a survey and then forward a summary of the comments for your review.

I would appreciate from you any comments regarding our implementation of the student flying program. If you can think of anything (either positive or negative) regarding how the program was handled, how the students were chosen or any other comments I would very much appreciate hearing them to improve the program for the future. Please feel free to call, FAX or write to me with any thoughts you might have before January 15, 1992.

Again, my thanks for all your help during this year's Jason Project. May I extend a wish for a joyous holiday season and perhaps for many, a well earned rest.

Regards,

Stephen F. Mealy
Remote Flying Coordinator