

AD-A252 365

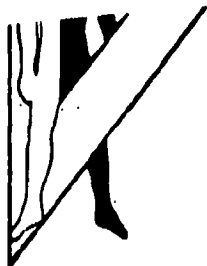

AD

2



Technical Note 5-92

MODELING THE EAR'S RESPONSE TO INTENSE  
IMPULSES AND THE DEVELOPMENT OF  
IMPROVED DAMAGE RISK CRITERIA

SDTIC  
ELECTE  
JUL 07 1992  
A D

G. Richard Price

May 1992  
AMCMS Code 611102.74A0011

Approved for public release;  
distribution unlimited.

U.S. ARMY HUMAN ENGINEERING LABORATORY

Aberdeen Proving Ground, Maryland

92 7 06 046

92-17525

**Destroy this report when no longer needed.  
Do not return it to the originator.**

**The findings of this report are not to be construed as an official Department  
of the Army position unless so designated by other authorized documents.**

**Use of trade names in this report does not constitute an official endorsement  
or approval of the use of such commercial products.**

**UNCLASSIFIED**

SECURITY CLASSIFICATION OF THIS PAGE

| REPORT DOCUMENTATION PAGE  |       |   |  | Form Approved<br>OMB No. 0704-0188                 |                         |
|--|-------|---|--|--|-------------------------|
| 1a. REPORT SECURITY CLASSIFICATION<br>Unclassified   |       | 1b. RESTRICTIVE MARKINGS  |  |  |                         |
| 2a. SECURITY CLASSIFICATION AUTHORITY  |       | 3. DISTRIBUTION/AVAILABILITY OF REPORT<br>Approved for public release;<br>distribution unlimited. |  |  |                         |
| 2b. DECLASSIFICATION/DOWNGRADING SCHEDULE  |       | 4. PERFORMING ORGANIZATION REPORT NUMBER(S)<br>Technical Note 5-92                                |  |  |                         |
| 5a. NAME OF PERFORMING ORGANIZATION<br>Human Engineering Laboratory  |       | 6b. OFFICE SYMBOL<br>(If applicable)<br>SLCHE   | 5. MONITORING ORGANIZATION REPORT NUMBER(S)          |  |                         |
| 6a. ADDRESS (City, State, and ZIP Code)<br>Aberdeen Proving Ground, MD 21005-5001  |       | 7a. NAME OF MONITORING ORGANIZATION   |  |  |                         |
| 7a. ADDRESS (City, State, and ZIP Code)  |       | 8a. NAME OF FUNDING/SPONSORING ORGANIZATION   |  | 8b. OFFICE SYMBOL<br>(If applicable)               |                         |
| 8a. ADDRESS (City, State, and ZIP Code)  |       | 9. PROCUREMENT INSTRUMENT IDENTIFICATION NUMBER   |  |  |                         |
| 8b. ADDRESS (City, State, and ZIP Code)  |       | 10. SOURCE OF FUNDING NUMBERS   |  |  |                         |
|  |       | PROGRAM ELEMENT NO.<br>6.11.02  | PROJECT NO.<br>L161102B74A                           | TASK NO.   | WORK UNIT ACCESSION NO. |
| 11. TITLE (Include Security Classification)<br>Modeling the Ear's Response to Intense Impulses and the Development of Improved Damage Risk Criteria  |       |   |  |  |                         |
| 12. PERSONAL AUTHOR(S)<br>Price, G. R.   |       |   |  |  |                         |
| 13a. TYPE OF REPORT<br>Final   |       | 13b. TIME COVERED<br>FROM _____ TO _____  |  | 14. DATE OF REPORT (Year, Month, Day)<br>1992, May | 15. PAGE COUNT<br>6     |
| 16. SUPPLEMENTARY NOTATION   |       |   |  |  |                         |
| 17. COBATI CODES   |       | 18. SUBJECT TERMS (Continue on reverse if necessary and identify by block number)                 |  |  |                         |
| FIELD  | GROUP | SUB-GROUP   | hazard rating spectrum, impulse noise                |  |                         |
| 23   | 02    |   | impulse noise  |  |                         |
|  |       |   | noise hazard   |  |                         |
| 19. ABSTRACT (Continue on reverse if necessary and identify by block number)<br>Research indicates that traditional measures fail to rate hazard from intense impulses accurately. This failure may be due to increased complexities in the ear's response at such high sound pressure levels. Therefore, to gain insight into the problem, we have been developing a mathematical model of the ear that reproduces the response of the ear from free field pressures to basilar membrane displacements and calculates hazard there (modeled as mechanical stress). This model is conformal with the structure of the ear and includes the spectral tuning of the external and middle ears, a non-linear stapes, and a changing susceptibility along the cochlear partition. The model can be used to calculate a hazard index for virtually any impulse and although work is still continuing on the development of the model, it is thus far able to "explain" the hearing loss data better than any other system. If the model were incorporated into an integrated circuit/meter, it would have the virtues of being complex enough to rate hazard accurately, be simple to use, and because it is theoretically based, be useful in suggesting design changes for impulse-producing sources as well as more effective designs for hearing protectors. |       |   |  |  |                         |
| 20. DISTRIBUTION/AVAILABILITY OF ABSTRACT<br><input type="checkbox"/> UNCLASSIFIED/UNLIMITED <input checked="" type="checkbox"/> SAME AS RPT. <input type="checkbox"/> DTIC USERS  |       |   | 21. ABSTRACT SECURITY CLASSIFICATION<br>Unclassified |  |                         |
| 22. NAME OF RESPONSIBLE INDIVIDUAL<br>Technical Reports Office   |       | 22b. TELEPHONE (Include Area Code)<br>(301) 278-4478  |  | 22c. OFFICE SYMBOL<br>SLCHE-SS-TSB                 |                         |

MODELING THE EAR'S RESPONSE TO INTENSE  
IMPULSES AND THE DEVELOPMENT OF  
IMPROVED DAMAGE RISK CRITERIA

G. Richard Price

May 1992

APPROVED:

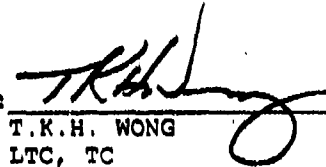

T.K.H. WONG  
LTC, TC  
Acting Director  
Human Engineering Laboratory

Approved for public release;  
distribution unlimited.

U.S. ARMY HUMAN ENGINEERING LABORATORY  
Aberdeen Proving Ground, Maryland

## Modeling the Ear's Response to Intense Impulses and the Development of Improved Damage Risk Criteria

G. Richard Price

U.S. Army Human Engineering Laboratory  
Aberdeen Proving Ground, Maryland 21005

**Abstract.** Research indicates that traditional measures fail to rate hazard from intense impulses accurately. This failure may be due to increased complexities in the ear's response at such high sound pressure levels. Therefore, to gain insight into the problem, we have been developing a mathematical model of the ear that reproduces the response of the ear from free field pressures to basilar membrane displacements and calculates hazard there (modeled as mechanical stress). This model is conformal with the structure of the ear and includes the spectral tuning of the external and middle ears, a non-linear stapes, and a changing susceptibility along the cochlear partition. The model can be used to calculate a hazard index for virtually any impulse and although work is still continuing on the development of the model, it is thus far able to "explain" the hearing loss data better than any other system. If the model were incorporated into an integrated circuit/meter, it would have the virtues of being complex enough to rate hazard accurately, be simple to use and because it is theoretically based, be useful in suggesting design changes for impulse producing sources as well as more effective designs for hearing protectors.



### Introduction

As the experimental evidence mounts, 4,12,17,19,20,28 it has become increasingly apparent that existing damage-risk criteria (DRCs) for intense impulsive sounds<sup>1,2,9,10,11,13,29</sup> are inadequate from two different perspectives. First, they fail to predict hazard accurately, especially for impulses with spectral peaks in the low frequency region.<sup>18,28</sup> Second, they are inadequate because they have almost no theoretical basis. This lack is a serious shortcoming because it means that existing DRCs can be applied with confidence only to those specific impulses used in their derivation. Extrapolation to different impulses can be made only with caution and without a theoretical basis, the DRCs offer no generally valid approach to dealing with issues like rating the effectiveness of different types of hearing protection or assessing hazard from pressure measurements made in other than free field conditions. It also means that existing DRCs can serve with limited utility as the basis for a design criterion for material, such as the one used in the US Army (MIL STD 1474(C)). These and other shortcomings of existing criteria have been discussed at greater length in other papers<sup>4,16,28</sup> and will not be further developed here.

The heart of the problem facing the designer of a DRC for impulse noise can perhaps be most easily illustrated by the waveforms in Figure 1. The three impulses in this figure (produced by a primer, rifle, and howitzer, respectively) have, with the same number of impulses and the same temporal spacing, all produced the same loss in the cat ear.<sup>24,25</sup> Yet, it is easy to see from an examination of the waveforms in Figure 1, that the measures commonly used in rating hazard, i.e., peak pressure and a measure of duration or energy, can hardly produce a rating of equal hazard for these impulses.

It is the basic contention of this paper that a DRC capable of encompassing the behavior of the ear at high intensities must account for non-linearities both as a function of frequency (the ear is spectrally tuned) and also as a function of intensity (there are mechanisms that act to limit large displacements).<sup>14,21,23</sup> Furthermore, we propose that such a DRC, if it is to be applied in practice, needs to be formulated in a manner very different from any in use today. In essence, what is needed is a mathematical model of the ear into which the test sounds can be "played" and the hazard calculated. Kalb and Price<sup>8,22</sup> have been

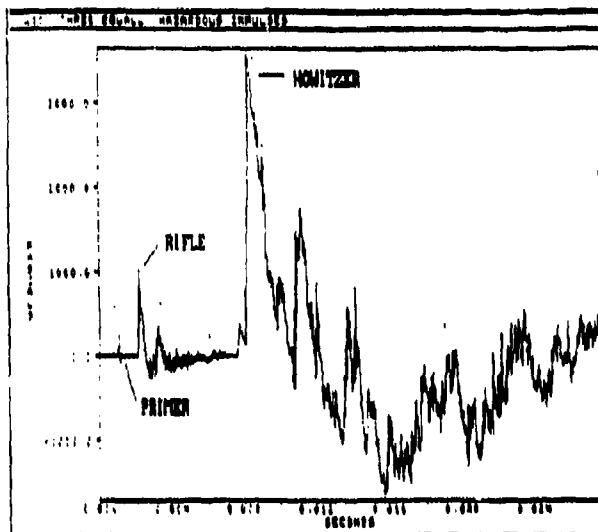

Figure 1. Three impulses demonstrated to be equally hazardous to the cat ear.

working on such a formulation for a number of years and this paper is a progress report on that effort.

### The Model

#### The External and Middle Ears

Briefly, the model is conceived in an electro-acoustic form that is conformal with the physiological structure of the ear (Figure 2). This structure in the model is perhaps more complex than needed to rate hazard; however, the model is also intended to promote physical insight into the processes associated with hazard. Thus, we can easily follow the flow of energy through the ear/model as we proceed from the free-field sound pressure, into the ear canal, through the middle ear, and into the cochlea. Furthermore, the model has a "place" to put a circumaural muff or an ear plug, should we wish to account for the wearing of hearing protection. Menus in the program allow the user to set values for 44 different variables (lengths, masses, stiffnesses, etc.).

#### Stapes Suspension

The annular ligament of the stapes effectively establishes a peak-limiting gateway into the cochlea. The ligament in the cat, for example, is capable of limiting the displacement of the stapes to about  $\pm 20$  microns.<sup>11,23</sup> For pure tone stimulation, peak limiting can become appreciable at pressures in the 130 dB region and it increases its effect as sound pressures rise from there. This is a pressure region in which weapons impulses are found (155 to 185 dB) and means that the full peak pressures are simply not transmitted to the cochlea.

#### The Cochlea

The cochlea is modeled with a tapered basilar membrane (BM) which becomes progressively more compliant toward the apex producing envelopes of traveling wave displacements that show a changing

Q and an increase in amplitude with increasing frequency as seen by von Békésy.<sup>30</sup> We believe that these envelopes are characteristic of the BM when driven at high amplitudes and are the same as those shapes actually seen in studies that have measured intracochlear motion.<sup>28</sup>

#### The Hazard Calculation

It is well known that the primary site for the physiological damage associated with hearing loss is within the structures on the BM. At these high intensities, we model the fundamental loss process like the fatigue of materials, keeping track of the number of BM flexions, their amplitudes and the width of the membrane at that location. (BM width becomes an issue because stress is conceived as a percentage change in length). Specifically, we calculate the displacements of all the points along the BM when the ear is exposed to a stimulus, correct for BM width, raise the peaks (in microns) to the 2.5 power and accumulate the result as the "hazard" at that location.

In the data reported here we focus specifically on the upward displacements of the

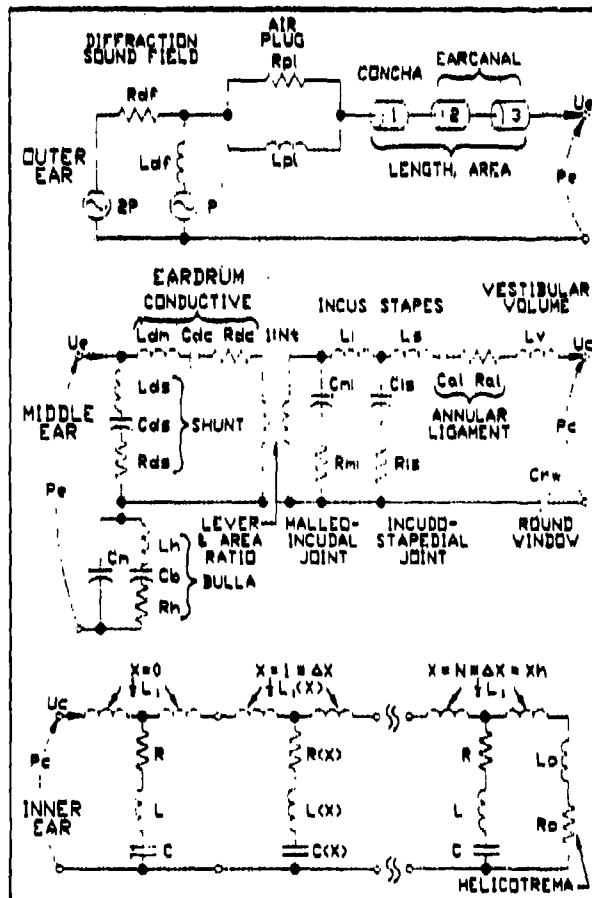

Figure 2. Schematic diagram of the model from the external ear to the cochlea. The energy flows from the top section (external ear), into the middle section (middle ear) and finally into the bottom section (cochlea).

basilar membrane (toward the scala vestibuli) because they appear to correlate best with the damage and have the additional advantage of making physiological sense as possible damage producers. Briefly, the latest conceptions of cochlear function associate upward displacement with forces that stretch critical parts of the organ of Corti, e.g., the tip links on the hairs of the hair cells. Given that tissue tends to fail in tension, upward displacements could well be especially hazardous.

#### Using the Model

Once the free field waveform is selected from a menu of available waveforms, the model calculates the stapes displacement resulting from the impulse and provides a display of the two waveforms.

#### The Exposure Movie

The model displays its final results in what has turned out to be not just a pleasing but an extremely useful fashion. Given the stapes displacement as an input, basilar membrane displacements are calculated for all (or selected) locations along the basilar membrane. Then they are organized so that they can be displayed sequentially with the result that a displacement movie of the entire membrane can be viewed as though the cochlea had been unrolled and a window installed in its side. When this movie is correlated with the pressure history of the pulse in air (simultaneously on the same video screen), it becomes possible to see just what part of the pressure waveform precedes what effect. We also calculate the hazard at the same time and display it inside the cochlea as well, so that it is possible to watch its growth as the impulse is propagated through the cochlea.

#### Fitting the Hearing Loss Data

It is crucial for the usefulness of the model that it in fact fit the data on hearing loss. As this is written we are still working on the details of calculating the hazard function as well as adding features to the model needed to reproduce the ear's response. The focus and space constraints of this paper do not allow for a detailed presentation and some details have already been published.<sup>8,2</sup> Briefly, the model matches the location of damage very well, calculating the maximum hazard for gunfire impulses to be mid-cochlea, regardless of the spectral peak of the impulses. It also explains the lower than expected losses from impulses with low spectral peaks. The model has had heuristic value in suggesting that, for the cat data at least, we need to assume that the middle ear muscles are continuously active in awake (unanesthetized) animals.<sup>15</sup> Perhaps the best summary statement at this point is that the model appears to be capable of fitting all the data we have available and have tested.

#### A New Form for a DRC?

Given that the model continues to rate hazard relatively accurately, could it not serve as the basis for a new DRC for impulse noise? We contend that given today's technology and tomorrow's promise, the possibility of a DRC being embodied

in a computer program is indeed feasible. The model as discussed here has been formulated to run on a PC-level computer and can perform the calculations to rate hazard or make a movie in a few minutes. The problem of getting a waveform into the computer is also now getting simpler. For example, various digitizing boards are available which will fit into a computer and in effect produce a hazard meter. So far as a user is concerned, the process is really not much more complex than use of existing criteria. The problems of getting an accurate measurement are still there, the only difference being that now you enter the process with a digitized waveform instead of a picture of it.

In return for this slightly greater complexity, there are important additional benefits. There is, of course, the promise of greatly increased accuracy; but the fact that the model is theoretically based offers important advantages. It becomes a useful tool for correcting problems by providing more than simple yes or no output. It is possible to see just which part of the waveform is producing the hazard and to focus corrective action in the proper place. Or it becomes a theoretical base upon which to found basic research programs in cochlear mechanisms or to build better hearing protectors as well as engineer safer weapons.

#### Prognosis

A preliminary version of this model has been provided to the members of NATO Research Study Group 6, Panel 8, on impulse noise, for their use and evaluation as a possible candidate for an international DRC for impulse noise. In the meantime, work is continuing to find the best possible values for use in the model to fit the greatest range of data on hearing loss from intense impulses. In addition, we are working to make the model as user-friendly as possible. Finally, as a means of both testing the model and "designing the problem out," we are conducting tests to find methods of ameliorating the hazard from impulse producing weapons by changing weapon design.

#### References

1. CHABA (1968) "Proposed Damage-Risk Criterion for Impulse Noise (Gunfire)," Report of Working Group 57, NAS-NRC committee on Hearing, Biocoustics and Biomechanics, Washington, DC
2. M. Cheng, Z. Liang, Z. Meng, and X. Li (1987) "Investigation of Military Standard for Impulse Noise," Proceedings of Inter-Noise 87, 2, 913-916.
3. A. R. Gody and I. J. Russell (1992) "Effects of Intense Acoustic Stimulation on the Nonlinear Properties of Mammalian Hair Cells," In A. L. Dancer, D. H. Henderson, R. J. Salvi, and R. P. Hamernik (Eds.), Noise-Induced Hearing Loss, 11-27, Mosby Year Book, St. Louis.
4. A. L. Dancer (1992) "Status and Shortcomings of Military Noise Standards," In A. L. Dancer, D. H. Henderson, R. J. Salvi, and R. P. Hamernik (Eds.), Noise-Induced Hearing Loss, 513-520, Mosby Year Book, St. Louis.

5. A. Dancer, M. Lenoir, K. Buck, and P. Vassout (1983) "Etude de l'influence du niveau de crete et la duree de bruits impulsifs, du type bruit d'arme produit en champ libre, sur l'audition du cobaye," Institut Franco-Allemand de Recherches de Saint-Louis, FR, Report 127/83, 70 pp.
6. L. Decory, A. L. Dancer, and J. Aran, (1992) "Species Differences and Mechanisms of Damage," In A. L. Dancer, D. H. Henderson, R. J. Salvi, and R. P. Hamernik (Eds.), Noise-Induced Hearing Loss, 73-88, Mosby Year Book, St. Louis.
7. R. P. Hamernik, J. H. Petterson, and R. J. Salvi (1987) "The Effect of Impulse Intensity and the Number of Impulses on Hearing and Cochlear Pathology in the Chinchilla," Journal of the Acoustical Society of America, 81, 1118-1129.
8. J. T. Kalb and G. R. Price (1987) "Mathematical Model of the Ear's Response to Weapons Impulses," In Proceedings of the Third Conference on Weapon Launch Noise Blast Overpressure, U.S. Army Ballistics Research Laboratory, Aberdeen Proving Ground, MD 21005.
9. MIL-STD 1474(C) (1990) "Noise Limits for Army Materiel," U.S. Army Missile Command, Redstone Arsenal, AL.
10. Ministry of Defense (1982a) "Acceptable Limits for Exposure to Impulse Noise from Military Weapons, Explosives and Pyrotechnics," Interim Def Stan 00-27/1, Ministry of Defense, Directorate of Standardization, First Avenue House, London, WC1V6HE, England.
11. Ministry of Defense (1982b) "Recommendation on Evaluating the Possible Harmful Effects of Noise on Hearing," Technical Coordination Group "Human Factors and Ergonomics," Direction Technique des Armements Terrestres, 9211 Saint-Cloud Cedex, France.
12. NATO Document AC/243 (Panel 8/RSC.6) D/9 (1987) Effects of impulse noise. Brussels, NATO.
13. F. Pfander (1975) Das Knalltrauma. New York: Springer-Verlag.
14. G. R. Price (1992) "Importance of Spectrum for Rating Hazard," In A. L. Dancer, D. H. Henderson, R. J. Salvi, and R. P. Hamernik (Eds.), Noise-Induced Hearing Loss, 349-360, Mosby Year Book, St. Louis.
15. G. R. Price (1991) "Middle Ear Muscle Effects during Gunfire Exposures," Journal of the Acoustical Society of America, 89, 1865.
16. G. R. Price (1987) "The Need for a New DRC for Impulse Noise," In Proceedings of the Third Conference on Weapon Launch Noise Blast Overpressure, U.S. Army Ballistics Research Laboratory, Aberdeen Proving Ground, MD 21005.
17. G. R. Price (1986a) "Hazard from Intense, Low Spectral Frequency Impulses," Journal of the Acoustical Society of America, 80, 1076-1086.
18. G. R. Price (1986b) "Impulse Noise Hazard as a Function of Level and Spectral Distribution," In R. J. Salvi, D. Henderson, R. P. Hamernik, and V. Coletti (Eds.), Basic and Applied Aspects of Noise-Induced Hearing Loss. Plenum Press.
19. G. R. Price (1983) "Relative Hazard of Weapons Impulses," Journal of the Acoustical Society of America, 73, 556-566.
20. G. R. Price (1981) "Implications of a Critical Level in the Ear for Assessment of Noise Hazard at High Intensities," Journal of the Acoustical Society of America, 69, 171-177.
21. G. R. Price (1974) "An Upper Limit to Stapes Displacement: Implications for Hearing Loss," Journal of the Acoustical Society of America, 56, 195-197.
22. G. R. Price and J. T. Kalb (1991) "Insights into Hazard from Intense Impulses from a Mathematical Model of the Ear," Journal of the Acoustical Society of America, 90, 219-227.
23. G. R. Price and J. T. Kalb (1986) "Mathematical Model of the Effect of Limited Stapes Displacement on Hazard from Intense Sounds," Journal of the Acoustical Society of America, 80, 8123.
24. G. R. Price, H. N. Kim, D. J. Lim and D. Dunn (1989) "Hazard from Weapons Impulses: Histological and Electrophysiological Evidence," Journal of the Acoustical Society of America, 85, 1245-1254.
25. G. R. Price and S. Wansack (1989) "Hazard from an Intense Mid-Range Impulse," Journal of the Acoustical Society of America, 85, 2185-2191.
26. W. S. Rhode (1980) "Cochlear Partition Vibration - Recent Views," Journal of the Acoustical Society of America, 67, 1696-1703.
27. W. S. Rhode and D. C. Geisler (1967) "Model of Displacement between Opposing Points on the Fectorial Membrane and Reticular Lamina," Journal of the Acoustical Society of America, 42, 185-190.
28. G. F. Smoorenburg (1992) "Damage Risk for Low-Frequency Impulse Noise: The Spectral Factor in Noise Induced Hearing Loss." In A. L. Dancer, D. H. Henderson, R. J. Salvi, and R. P. Hamernik (Eds.), Noise-Induced Hearing Loss, 313-324, Mosby Year Book, St. Louis.
29. G. F. Smoorenburg (1980) "Damage Risk Criteria for Impulse Noise." Rept. 1980-26, Institute for Perception TNO, Soesterburg, The Netherlands.
30. G. von Bekeay (1949) "On the Resonance Curve and the Decay Period at Various Places on the Cochlear Partition," Journal of the Acoustical Society of America, 21, 245-254.