

ARI Research Note 92-54

AD-A252 886

①



Development of a Computer-Supported Data Collection System to Measure Soldier Performance on the Institutional Fire Control System Trainer

Ronald D. Kaye and Xongping Xu

Allen Corporation of America

Linda G. Pierce

U.S. Army Research Institute

for

**Contracting Officer's Representative
Arthur Marcus**

**Field Unit at Fort Sill, Oklahoma
Edwin R. Smootz, Acting Chief**



**MANPRINT Division
Robin L. Keese, Director**

June 1992



92-18822



**United States Army
Research Institute for the Behavioral and Social Sciences**

Approved for public release; distribution is unlimited.

92 7 15 02:4

U.S. ARMY RESEARCH INSTITUTE FOR THE BEHAVIORAL AND SOCIAL SCIENCES

**A Field Operating Agency Under the Jurisdiction
of the Deputy Chief of Staff for Personnel**

**EDGAR M. JOHNSON
Technical Director**

**MICHAEL D. SHALER
COL, AR
Commanding**

Research accomplished under contract
for the Department of the Army

Allen Corporation of America

Technical review by

Dorothy Finley
John M. Lockhart

NOTICES

DISTRIBUTION: This report has been cleared for release to the Defense Technical Information Center (DTIC) to comply with regulatory requirements. It has been given no primary distribution other than to DTIC and will be available only through DTIC or the National Technical Information Service (NTIS).

FINAL DISPOSITION: This report may be destroyed when it is no longer needed. Please do not return it to the U.S. Army Research Institute for the Behavioral and Social Sciences.

NOTE: The views, opinions, and findings in this report are those of the author(s) and should not be construed as an official Department of the Army position, policy, or decision, unless so designated by other authorized documents.

REPORT DOCUMENTATION PAGE

Form Approved
OMB No. 0704-0188

Public reporting burden for this collection of information is estimated to average 1 hour per response, including the time for reviewing instructions, searching existing data sources, gathering and maintaining the data needed, and completing and reviewing the collection of information. Send comments regarding this burden estimate or any other aspect of this collection of information, including suggestions for reducing this burden, to Washington Headquarters Services, Directorate for Information Operations and Reports, 1215 Jefferson Davis Highway, Suite 1204, Arlington, VA 22202-4302, and to the Office of Management and Budget, Paperwork Reduction Project (0704-0188), Washington, DC 20503

1. AGENCY USE ONLY (Leave blank)		2. REPORT DATE 1992, June	3. REPORT TYPE AND DATES COVERED Final Feb 90 - Jan 91	
4. TITLE AND SUBTITLE Development of a Computer-Supported Data Collection System to Measure Soldier Performance on the Institutional Fire Control System Trainer			5. FUNDING NUMBERS DAHC35-89-C-0027 62785A 790 2209 C	
6. AUTHOR(S) Kaye, Ronald D.; and Xu, Xongping (Allen Corporation of America); Pierce, Linda G. (ARI)				
7. PERFORMING ORGANIZATION NAME(S) AND ADDRESS(ES) Allen Corporation of America 209 Madison Street Alexandria, VA 22314			8. PERFORMING ORGANIZATION REPORT NUMBER --	
9. SPONSORING / MONITORING AGENCY NAME(S) AND ADDRESS(ES) U.S. Army Research Institute for the Behavioral and Social Sciences ATTN: PERI-S 5001 Eisenhower Avenue Alexandria, VA 22333-5600			10. SPONSORING / MONITORING AGENCY REPORT NUMBER ARI Research Note 92-54	
11. SUPPLEMENTARY NOTES Contracting Officer's Representative, Arthur Marcus				
12a. DISTRIBUTION AVAILABILITY STATEMENT Approved for public release; distribution is unlimited.			12b. DISTRIBUTION CODE --	
13. ABSTRACT (Maximum 200 words) This report describes a data collection system developed to interface with Institutional Fire Control System Trainers (IFCSTs), which are trunk-size M109A6 Paladin howitzer Automatic Fire Control Computer System (AFCS) simulators. The IFCST simulates tasks performed by the Paladin chief-of-section when interfacing with the actual Paladin AFCS. The IFCST Data Collection System (DCS) links a data collection microcomputer with up to 18 individual IFCST units, records individual performance on scenario function (e.g., total number of errors committed during a scenario, total time required to complete a scenario, and total number of keystrokes required to complete a scenario), and stores these data in dBASE IV data files. The dBASE IV system then generates three types of reports summarizing the data at varying levels of detail.				
14. SUBJECT TERMS Paladin howitzer 13B30 MOS Performance data collection Computer system IFCST Training Simulators dBASE IV			15. NUMBER OF PAGES 37	
			16. PRICE CODE --	
17. SECURITY CLASSIFICATION OF REPORT Unclassified	18. SECURITY CLASSIFICATION OF THIS PAGE Unclassified	19. SECURITY CLASSIFICATION OF ABSTRACT Unclassified	20. LIMITATION OF ABSTRACT Unlimited	

FOREWORD

One of the initial MANPRINT issues cited for the Field Artillery's latest self-propelled howitzer, the M109A6 Paladin howitzer (Paladin), is whether or not the entire population of 13B30s can perform the tasks required of the Chief-of-Section (COS). Principal among the concerns was whether all members of this population could effectively interface with the on-board Automatic Fire Control Computer System (AFCS), as well as accomplish the other tactical decision-making, navigation, and crew supervisory tasks associated with this position.

To address these concerns, a system was designed to collect student performance data from training simulator units of the Paladin AFCS, the Institutional Fire Control System Trainer (IFCST). This system, the IFCST Data Collection System (DCS), links a data collection microcomputer with up to 18 IFCST units, records individual performance on scenario functions (i.e., time, keystrokes, and errors), and stores these data in dBASE IV data files. The system then generates three types of reports summarizing the data at varying levels of detail.

The results of this effort were briefed to representatives of the U.S. Army Field Artillery School Directorate of Combat Developments, TRADOC Systems Manager-Cannon; Gunnery Department; Directorate of Training and Doctrine; and to representatives of the Program Manager-Paladin on 21 December 1990.

The IFCST DCS developed from this effort may be used to provide feedback to Paladin COS trainees and trainers on student and class performance. It may also be used as a guide for developing similar systems in the U.S. Army.

DTIC QUALITY INSPECTOR

Accession For	
NTIS GRA&I	<input checked="" type="checkbox"/>
DTIC TAB	<input type="checkbox"/>
Unannounced	<input type="checkbox"/>
Justification	
By _____	
Distribution/	
Availability Codes	
Dist	Avail and/or Special
A-1	

DEVELOPMENT OF A COMPUTER-SUPPORTED DATA COLLECTION SYSTEM TO
MEASURE SOLDIER PERFORMANCE ON THE INSTITUTIONAL FIRE CONTROL
SYSTEM TRAINER

CONTENTS

	Page
OVERVIEW	1
Description of the IFCST	2
DEVELOPMENT OF AN AUTOMATED MULTI-STATION, IFCST-RELATED DATA COLLECTION CAPABILITY	3
Data Collection Requirement	3
Capabilities of the IFCST DCS	5
Installing and Using the System	9
IFCST-Related Administrative Requirements	22
APPENDIX A. DESCRIPTIONS OF DECISIONS REGARDING ANCILLARY COS TASKS AND SOURCE CODE	A-1
B. IFCST DCS EQUIPMENT	B-1
C. ABBREVIATIONS AND ACRONYMS	C-1

LIST OF FIGURES

Figure 1. The DCU and SIU displays of the IFCST unit . . .	2
2. IFCST DCS device activity monitor screen	10
3. The select report screen	11
4. The report screen	12
5. The report data specification screen	13
6. The individual data file selection screen . . .	13
7. Sample format of the long report	17
8. Sample format of the short report	20
9. Sample format of the standard report	21

DEVELOPMENT OF A COMPUTER-SUPPORTED DATA COLLECTION SYSTEM TO MEASURE SOLDIER PERFORMANCE ON THE INSTITUTIONAL FIRE CONTROL SYSTEM TRAINER

Overview

One of the initial MANPRINT issues cited for the Field Artillery's latest self-propelled howitzer, the M109A6 Paladin howitzer (Paladin), was whether or not the entire population of 13B30s (Military Occupational Specialty designator for cannon crew member skill level three soldiers) could perform the tasks required of the Chief-of-Section (COS). Principal among these concerns was whether all members of this population could effectively interface with the on-board Automatic Fire Control Computer System (AFCS) as well as accomplish the other tactical decision making, navigation, and crew supervisory tasks associated with this position.

To address these concerns, it was proposed that a system be designed to collect objective student performance data from training simulator units of the Paladin AFCS, the Institutional Fire Control System Trainer (IFCST). This system, the IFCST Data Collection System (DCS), links a data collection microcomputer with up to 18 IFCST units, records individual performance on scenario functions (i.e., time, keystrokes, and errors), stores the data in dBASE IV data files, and generates reports summarizing the data.

In addition, it was proposed that software and hardware requirements be identified and developed for coarsely representing and simultaneously superimposing non-AFCS-related COS tasks (e.g., radio communication, navigation, and decision making) during the "test" scenario used in IFCST data collection. However, discussions with Paladin and IFCST experts at Fort Sill revealed that the overlay of ancillary COS tasks was not appropriate for the IFCST simulation process. Thus, the requirement was deleted. Instead, it was decided to capture data from all four of the scenarios rather than from a single scenario. A more detailed account of this decision is given in Appendix A.

This report describes the IFCST DCS, beginning with a general description of the IFCST and the necessary hardware and software components to run the IFCST. Following this, instructions for installing and using the system are given. Specifically, instructions are given on how to load, run, and shut down the data collection and data reporting capabilities of the system as well as how to generate reports summarizing the data. In the next section, general guidelines and operational recommendations for using the IFCST DCS in a classroom setting are given. Finally, a detailed description of the IFCST DCS equipment and an acronym list are given in Appendixes B and C, respectively.

Description of the IFCST

The IFCST is an interactive, trunk-sized, tabletop, videodisc-supported trainer. As seen in Figure 1, the IFCST uses two displays: the Display Control Unit or DCU (a functional replication of the Paladin on-board AFCS) and the Student Interactive Unit or SIU (used to select the type of instruction or instruction module desired and to convey other scenario relevant information to students). A major portion of the tasks requiring interface with the Paladin AFCS are addressed by the IFCST.

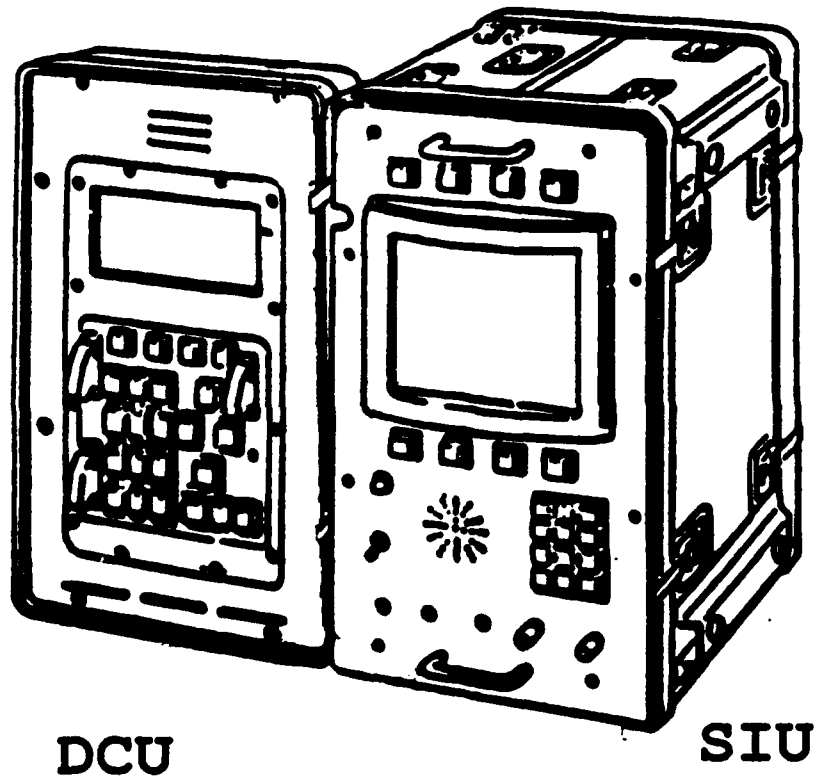

Figure 1. The DCU and SIU Displays of the IFCST Unit. (The DCU display is shown on the left and the SIU display is shown on the right).

The IFCST SIU provides an initial menu of nine tutorial descriptions of the functions and operation of the various components of the AFCS. These descriptions include still-frame and animated pictorials of the AFCS and related components as they appear within the Paladin. This information is accompanied

by audio information delivered via headphones and an external speaker.

The IFCST provides a Practice Mode and a Scenario Mode. In the Practice Mode, an abbreviated scenario is presented in which students complete tasks one at a time. In the Scenario Mode, the tasks are generated automatically in a sequence that simulates events likely to occur during a normal fire mission. If students make an error during an attempt to execute a task in either of these modes, they are provided immediate feedback via the appearance of a red warning screen on the SIU describing, in a textual format, the general nature of their error. Following the completion of scenarios in either mode, the student can elicit a performance summary screen that provides a synopsis of errors made by various categories.

Development of an Automated Multi-Station, IFCST-related Data Collection Capability

Data Collection Requirement

The existing configuration of the IFCST does not allow the offloading of performance-related data to a central data base repository for single IFCST units or multiple units operating simultaneously. The IFCST does, however, provide an abbreviated performance report. This report consists only of the number of errors committed for an entire scenario summarized by error type. Because the performance report is not offloaded automatically, the instructor or student must enter instructions for this to be done. There are several major drawbacks inherent in the existing IFCST system which make it unsuitable for the collection of human performance data:

1. The data provided by the existing IFCST performance reporting system is minimal; that is, it is not of sufficient detail to support valid conclusions pertaining to performance variability within the 13B30 population or other research requirements.
2. Due to the present IFCST system configuration, there is considerable risk that data will be missed or that it will be biased due to the natural desire of students to avoid generating a record of their poorer performances.
3. There is no capability for storing performance data in a central repository to allow for comparisons between individual and class performance and for performance data to be archived and used at a later date.

In order to support valid research on IFCST-related student performance, empirical measures such as the time and number of keystrokes required to execute each IFCST scenario function, and the errors associated with each function must be collected from

the existing IFCST in a non-intrusive fashion. It is also necessary to compare individual performance measures with class performance to allow for the effects of different trainers or training programs and to compare the performance of each student with established standards of performance. The IFCST DCS satisfies these human performance data requirements by collecting the aforementioned empirical measures with specialized hardware and software.

Supporting Material Specification

The first steps in developing the IFCST DCS were to evaluate the IFCST data processing hardware and software, determine an approach for data capture, and specify the hardware and software components required. It was specified that the IFCST DCS be applied to 18 IFCST units to allow for student data from each unit to be directed to a common storage device (Bernoulli disk) on an IBM compatible 80386 microcomputer. Computer code was required to perform the functions for capturing, reducing, downloading, storing, and reporting the data. In addition, it was specified that the data be stored on dBASE IV files.

Use of the IFCST

To place the IFCST in the context of the data collection requirement as it will exist, a brief description of the use of the IFCST is provided. The Army plans to use the IFCST for training and instruction within a classroom setting. Students will power up a given IFCST unit on the SIU portion of the device. At this point, the system initializes and performs internal tests. When this process has been completed, the student is presented with an initial menu on the SIU. This initial menu allows the student to select Practice Mode or Scenario Mode. When the scenario mode is selected, a menu is provided allowing the student to choose scenarios 1, 2, 3, or 4.

Each of the scenarios exposes the student to a set of requirements that are somewhat different according to the specific requirements of the mission involved. The title of Scenario 1 as it appears in the documentation (no title other than Scenario 1 is provided on the IFCST menu) is "Shoot Heavy." Similarly, Scenario 2 is "Balanced," Scenario 3 is "Move Heavy," and Scenario 4 is another version of "Balanced." The values required to initialize Net Access and Net Address are different for each scenario. In addition to other parameters, the ammunition inventory requirements, number of rounds fired, and target coordinates also vary across scenarios.

After the student selects a scenario, the system asks the student to choose between manual or automatic ammunition selection. Manual selection requires the student to enter the ammunition for the mission. In automatic selection, which is the

default selection, the system will automatically specify the ammunition. However, in order to collect interpretable data, using the IFCST DCS, students must select the manual selection option. Otherwise, the system will not store the performance data by scenario (i.e., data will be stored as scenario version "5" in the data files regardless of which scenario was run). Consequently, performance statistics (e.g., class averages and standard deviations) will be affected because data will be sorted by an additional category.

At this point, the student should activate the DCU portion of the system. The DCU presents the student with a replica of the on-board Paladin AFCS. After the DCU is activated, the student will perform the scenario by following the instructions on the SIU and DCU screens and by using the numerical input and variable purpose function keys on the DCU. After the scenario has been completed, the student may either turn the IFCST off or proceed to another Scenario.

Capabilities of the IFCST DCS

Because the source code was unavailable, it was decided to measure performance by scenario function rather than by individual keystroke (for additional discussion on this issue, see Appendix A). The performance data captured and stored by the IFCST DCS includes time required to perform each function, the number of keystrokes used per function, and the number of times that the student attempted to enter erroneous information per function. These measures are also totaled for the entire scenario (i.e., all of the time and keystrokes required and errors committed during the execution of all of the functions in a given scenario).

The performance data files created by the IFCST DCS are labeled to enable separate comparisons of individual performance as well as the performance of the entire class. The system will allow for both raw scores and summary data pertaining to class and individual performance to be printed out. The structure of the data files in the data base, including information pertaining to the date and time on which the data were collected for each file, will enable analyses of previously collected data to be performed at a later date.

The hardware components were selected and the software components developed to enable student IFCST performance to be stored in a readily accessible format (i.e., dBASE IV files). The hardware and software of the IFCST DCS were selected, configured, and designed specifically for interface and data retrieval for up to 18 IFSTs operating simultaneously.

Hardware Components

The major hardware component of the system is a 386 microcomputer that has been modified to accept data communication from the IFCST units (see Appendix B). This microcomputer has a very fast (33 MHz) clock speed enabling it to rapidly monitor 18 IFCSTs and record student responses.

The connections between the 386 data collection microcomputer and the (up to) 18 IFCSTs is accomplished by three 8-port multi-serial port controller cards installed in the microcomputer; 18, 8-wire phone cables; and an RS232-to-8-wire adaptor. The RS232-to-8-wire adaptor links the RS232 serial port on the IFCST to each 8-wire data connection cable for each cable connecting an IFCST to the data collection microcomputer. Note that the RS232 to 8-wire adaptor is required because of the RS232-type serial port (serial port #2) on the IFCST and the 8-wire input connections on the multi-serial port data communication controller cards (see Appendix B).

The data collection microcomputer contains programs written in C to capture, format, and download IFCST student response data into dBASE IV files. Code developed in Clipper (a data base programming language and compiler compatible with dBASE IV which allows for faster execution of program code) is also provided specifically to create summary reports from the data.

The hardware was selected to accommodate a classroom setting with a minimum of imposition due to the presence of the IFCST DCS hardware. The connection cables, 50 feet long, are long enough to reach each of the IFCST units. The programs that control the data collection which run on the data collection microcomputer require very little interaction by a data collection supervisor while students are running scenarios on the IFCSTs.

Software Components

The software consists of executable code written and compiled in C and Clipper. The data files (.dbf) themselves are all dBASE IV files. The data capture portion of the software is intended to be run on a 386 microcomputer. The data reporting software will perform best if the microcomputer is a 286 or a 386 (preferred). The major software components are:

1. The code responsible for allowing the data collection computer to monitor the 18 ports connected to the IFCSTs.
2. The code responsible for collapsing human performance data from the raw form received from each IFCST for time, keystrokes, and errors, for individual scenario functions.
3. The code responsible for creating file names and header

information and storing the performance data in the appropriately named data file.

4. The code responsible for creating files of data file names required by the system and for shutting down the data collection process.

5. The code responsible for converting coded data files into a text file and appending this file to the dBASE IV file structure.

6. The code responsible for extracting required data from dBASE IV data files, performing required statistical analyses on these data, and formatting and printing summary reports.

Software components 1-4. The program code components 1-4 are subsumed in the same program, "COLLECT.EXE," which is written and compiled in C. The COLLECT program, when activated, initializes the 18 communication ports on the data collection microcomputer and clears the data buffers on the IFCSTs. After this is done, a message is provided to the data collection supervisor to "Turn on Devices." At this point, the IFCSTs to be used may be activated. The program causes each of the 18 ports to be scanned and automatically records data in real time from active ports.

As the performance data are received, they are reduced (i.e., time tags per function are subtracted to determine the performance time per function and keystrokes and warning screens per function are totaled) and written to coded data files by the program. COLLECT.EXE develops a header for each coded data file. The header contains the file name, the scenario (1-4) being run, and whether the version of the scenario is "hot" or "cold." In a cold scenario version, the student would turn on the IFCST unit and modify several parameters associated with the functions of the scenario. For example, the functions leading up to the fire mission sequence involve the modification of parameters for approximately 12 functions such as Net Access and Ammo Inventory. In a hot version, the student would complete one scenario and proceed directly into another scenario (i.e., without shutting off the DCU) where many of the updates would remain as modified.

The name portion of the header for the coded data files is located in the following columns:

1. Column 1: A letter (A-R) identifying the IFCST unit (1-18) on which the data was collected.

2. Columns 2 and 3: The month in which the data were collected.

3. Columns 4 and 5: The day of the month on which the data were collected.

4. Columns 6 and 7: The time in military hours in which the data were collected.

5. Column 8: The time in 10 minute intervals. For example, "0" means from 0 to 9 minutes after the hour, "2" means from 20 to 29 minutes after the hour, and so on.

The identification of the IFCST unit, month, day, hour, and minute is given in the following format:

A 12 17 14 2 .

Thus, "A" refers to the IFCST unit, "12" indicates the month of December, "17" refers to the seventeenth day, "14" means that data was collected at 1400 hours (i.e., 2 p.m.), and "2" indicates that the data was collected from 20 to 29 minutes after the hour. This format is used as a file name for coded data files containing all of the information necessary to identify them within the eight spaces allowed by the DOS environment for file names. For example, a coded data file named from the example above would be "A1217142"(no extension).

COLLECT.EXE also creates a text file of coded data file names (i.e., NAMELIST.TXT) to support the generation of reports summarizing data from the last data collection session. This file is erased and replaced with new coded data file names for each data collection session. Moreover, a master list of coded data file names is created or appended for each new coded data file developed. This file stores all of the coded data files held by the IFCST DCS.

In addition, the COLLECT.EXE program constantly monitors use of the "Esc" key. When the data collection supervisor presses the Esc key, the data collection session is ended and all of the coded data files are closed.

Software component 5. The functions described in this component are performed by the "REPORT.EXE" program. The REPORT.EXE program is activated when the user begins the data reporting sequence. The main function performed by REPORT.EXE is converting the coded performance data files into a dBASE IV data format allowing access by the report generation programs. To accomplish this, the REPORT.EXE program calls additional programs as required. The conversion of the coded data files to a text file is accomplished by SFILECON.EXE and FILECON.EXE. The resulting text file is called REP_FILE.TXT. The data in REP_FILE.TXT are then appended to the empty dBASE IV file called TODAY_RE.DBF.

Software component 6. The functions discussed here are also controlled by the REPORT.EXE program. As per the report specifications entered by the user for creating a summary report, certain data files or the data files from the last data

collection session are downloaded into the TODAY_RE.DBF file as described above. The TREE.EXE program gives the user the option of specifying individual coded data files to be selected and downloaded into TODAY_RE.DBF. The specific report (i.e., Long, Short, or Standard) selected will incorporate data from TODAY_RE.DBF, perform the calculations required by the report format, and print the report.

Installing and Using the System

Two disks are provided with the IFCST DCS. Disk 1 contains the executable and required dBASE IV file structures to enable the IFCST DCS to be run. Disk 2 contains the source code for the executable files that will allow a programmer to modify any of the IFCST DCS files.

The executable files required to run the IFCST DCS are:

COLLECT.BAT,
COLLECT.EXE,
SFILECON.EXE,
FILECON.EXE,
TREE.EXE,
REPORT.EXE, and
KEEP.DBF.

The dBASE IV files required are:

EXPERT.DBF,
EXPERT.MDX,
TODAY_RE.DBF, and
TODAY_RE.MDX.

An additional file is provided to allow reports to be printed from a microcomputer other than the data collection microcomputer. This is the EXREPORT.EXE program. This file must be copied to the disk containing all the dBASE IV files taken from the data collection microcomputer to enable the IFCST DCS data reports to be printed.

To run the IFCST DCS, disk 1 should be copied to its own subdirectory, the name of which can be specified by the user. The source code files on disk 2 may be modified or used at the user's discretion. Assuming that the subdirectory to which the IFCST DCS will be copied is named "IFCST" and the IFCST subdirectory resides on the C drive, the system will be activated by typing "Collect" at the DOS prompt:

```
C:\IFCST>Collect (Return) .
```

Using the IFCST DCS. After typing Collect at the DOS prompt, the system will begin with a message "Turn on IFCST

Devices." As the IFCSTs are turned on, the system will indicate that the data communication connection between the data collection microcomputer is functioning and receiving input from the IFCST device. The device letter designator for each active IFCST, the name of the file, and the version of the scenario that performance data is being recorded from is displayed on the monitor. This screen is called the Device Activity Monitor Screen (see Figure 2). Assuming that all 18 IFCSTs are connected and activated, the screen would display the information provided in Figure 2. Note that the displays are oriented in six rows of three IFCST units each.

Turn ON IFCST Devices

Device A is Working ... File Name is: A0105114 Scenario 1, Cold	Device B is Working ... File Name is: B0105112 Scenario 2, Cold	Device C is Working ... File Name is: C0105101 Scenario 1, Cold
Device D is Working ... File Name is: D0105094 Scenario 4, Cold	Device E is Working ... File Name is: E0105082 Scenario 3, Hot	Device F is Working ... File Name is: F0105081 Scenario 1, Hot
Device G is Working ... File Name is: G0105134 Scenario 2, Cold	Device H is Working ... File Name is: H0105112 Scenario 2, Cold	Device I is Working ... File Name is: I0105101 Scenario 1, Cold
Device J is Working ... File Name is: J0105112 Scenario 2, Cold	Device K is Working ... File Name is: K0105125 Scenario 2, Hot	Device L is Working ... File Name is: L0105101 Scenario 4, Cold
Device M is Working ... File Name is: M0105114 Scenario 1, Cold	Device N is Working ... File Name is: N0105112 Scenario 2, Cold	Device O is Working ... File Name is: O0105101 Scenario 3, Cold
Device P is Working ... File Name is: P0105112 Scenario 2, Cold	Device Q is Working ... File Name is: Q0105142 Scenario 2, Hot	Device R is Working ... File Name is: R0105101 Scenario 2, Cold

Figure 2. The IFCST DCS Device Activity Monitor Screen.

The screen shown in Figure 2 remains in place as the data collection process occurs. The only part of the screen that will change will be the scenario number and scenario version as students proceed from one scenario to another.

After the last student is finished, the data collection supervisor presses the Esc key on the data collection microcomputer keyboard. At this point, the data collection session is ended, and the performance data files are automatically saved. Note that the names of the data files will be the same as those displayed on the Device Activity Monitor Screen. If Esc is pressed before a scenario is completed, the data for that scenario will be lost, however previously completed scenario data will be saved. Also note that if any of the IFCST SIUs are turned off before Esc is pressed on the data collection

microcomputer, all of the data for the scenario which was being run on that particular unit will be lost. No IFCST SIUs should be turned off before the data collection session is ended unless the data are useless for some reason, (e.g., a student must leave in the middle of the first scenario run).

Reporting Data

Selecting and printing reports. To report performance data, the user specifies the report content on the data collection microcomputer by typing "Report" at the DOS prompt:

```
C:\>Report (Return) .
```

The data reporting portion of the IFCST DCS will provide the initial report screen "Select Report" shown in Figure 3.

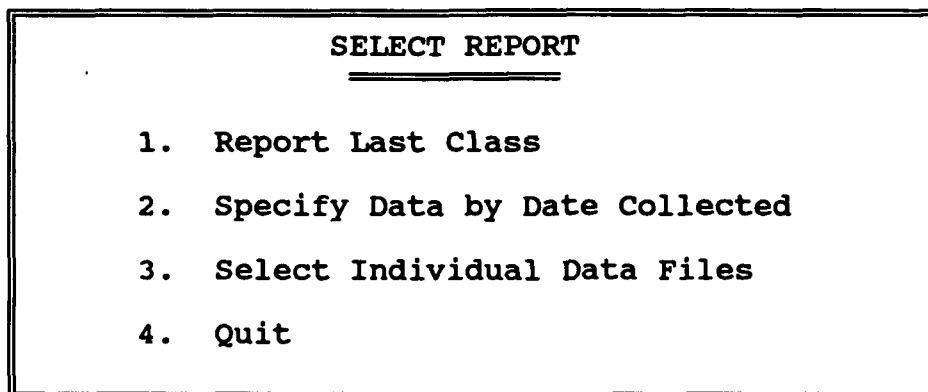

Figure 3. The Select Report Screen.

Option 1. As seen in Figure 3, the user has four options. Option 1, Report Last Class, automatically selects the data files in the last data collection session and creates the dBASE IV file, TODAY_RE.DBF necessary for the report to be run. The system then moves to the next screen called "Report" as shown in Figure 4. The Report screen offers the user a choice of three reports: the Long Report, the Short Report, and the Standard Report.

If the report is to be printed from a microcomputer other than the data collection microcomputer, the user will select the quit option on the Report Screen. Note that this procedure is followed for report data specification options 1, 2, and 3. The user will then copy the TODAY_RE.DBF file to the disk that will be used to transport the data. The EXREPORT.EXE file must also

be on this disk or must be on the microcomputer from which the data will be printed.

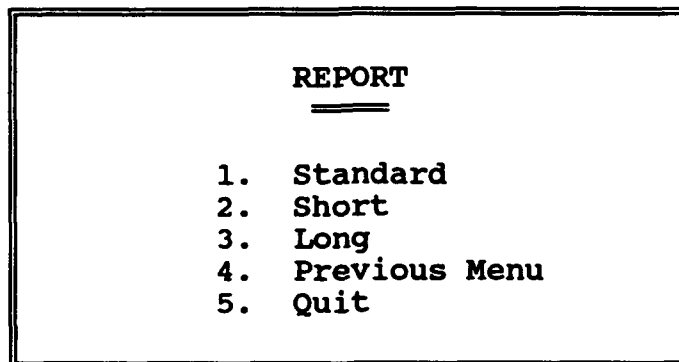

Figure 4. The Report Screen.

Option 2. Option 2 of the Select Report screen allows the user to specify data files to be reported by the date on which they were collected. When this option is chosen, the user is presented with the Report Data Specification screen shown in Figure 5. As described previously, the Report screen offers the user a choice of three reports (i.e., Long, Short, and Standard). The user enters data for any one or all of the Month, Day, Device ID, Hour, or "Minute by 10" fields. After all of the fields of interest have been entered, the user answers "Y" to the question "Are all Entries Correct? (Y/N)". If the user would like to reenter any of the fields, the user enters an "N" and the system allows the fields to be reentered.

If the user enters only one field, the system will match that entry with all data file names corresponding to that entry. The user must specify files until the group of desired files is obtained. For example, if the user enters only "12" after the Month field and leaves the remainder of the fields blank, the system will select all data files that were collected in the month of December. Note that after the Report Data Specification data has been entered, the system presents the user with a list of the files "targeted" for the report. Upon inspecting this group of files, the user has the option to report the data or re-specify the data (see Figure 5). The system then proceeds to the Report Screen.

REPORT DATA SPECIFICATION

Please enter the following information as appropriate

Month 12

Day

Device ID

Hour

Minute by 10

Are all Entries Correct (Y/N) Y

Report this Data (Y) or Respecify Data (N)

Figure 5. The Report Data Specification Screen.

If the report is to be printed from a microcomputer other than the data collection microcomputer, the same process described in Option 1 should be followed.

Option 3. If the user selects Option 3, "Select Individual Data Files," on the Select Report menu, the Individual Data File Selection Screen is presented. This screen shows a list of all files in the data base (see Figure 6). The user can then move the light bar over the files desired for the report and select them by pressing "Return." When all of the desired files have been selected, the user presses Esc and the system displays the Report Screen.

<< INDIVIDUAL DATA FILE SELECTION >>

A0109185
A1204091
A1218222
C0108074
D0109185
P1201091

Figure 6. The Individual Data File Selection Screen.

If the report is to be printed from a microcomputer other than the data collection microcomputer, the same process described in Option 1 should be followed.

Exporting Data to Print from a Separate Microcomputer

To print a data summary report from a microcomputer other than the data collection microcomputer, it is necessary to ensure that the files EXREPORT.EXE and EXPERT.DBF are copied to, or reside on, the microcomputer that will print the report. Follow any of the three processes already described for specifying the report data up to the Report screen. However, at the Report screen select the "Quit" option. Copy the TODAY_RE.DBF file to the disk that will be taken to the other microcomputer (e.g., Bernoulli or other type of disk). To run the EXREPORT.EXE program from the microcomputer, type "Exreport" at the DOS prompt:

```
C:\>Exreport (Return) .
```

The system will then present the user with the Report screen. Note that the data specification process will have already been performed at this point, and the user need only select one of the reports.

Description of Reports

Some of the data provided in the data summary reports are calculated by the reporting code from the data in the data files (e.g., averages and standard deviations). The raw scores presented by the report are taken directly from the data files.

The data in the reports are broken down into meaningful and useful components. First, the data are broken down by what is referred to on the IFCST as "scenario mode" (i.e., scenario 1 - 4). In addition, the data are broken down according to scenario version (i.e., cold or hot). Note that because the data resulting from hot and cold versions are different, they should not be compared, grouped, or averaged together.

The data are also grouped by IFCST device letter designation (e.g., A, B, and C). This component of the data base identifies individual students. Note that in this text, the IFCST device designator will be used synonymously with "student" because data that is referred to as "for each student" is the same as "for each unique IFCST identifier."

For a given combination of scenario mode, version, and student, performance data is presented by function within that scenario. The function name is provided and is followed by three

rows of data, one for each of the three components of human performance data measured: time required, keystrokes, and errors.

Each of these data designators is followed by five columns of data. The first is the raw score for the student, the second is the class average for that function and measure, the third is the standard deviation for the class data for that measure, the fourth is the difference between the student's score and the class average, and the fifth is an "expert reference" score. The expert reference score refers to the score obtained by an expert (i.e., an experienced user of the Paladin AFCS and the IFCST) performing the same functions as the student.

After the data corresponding to the last function in a scenario is reported by the system, the system sums all of the performance measures for the student for the entire scenario. The system then proceeds to the next student for the same scenario and scenario version in exactly the same fashion. When performance data for all of the students for a given scenario and version have been printed, the report continues with a summary of the data. The summary includes an average for all of the students in the group for each of the performance measures as well as a corresponding value from the expert reference data file.

Three data summary reports are provided by the IFCST DCS software: the Long Report, the Short Report, and the Standard Report. These three reports were developed to meet three requirements of the system:

1. The Long Report provides the user with a comprehensive summary of the human performance data as they exist on dBASE IV data files for the target data of interest.

2. The Short Report provides the instructor, the student, or both with a rapidly printed summary of IFCST scenario performance compared to the average for the class and an expert reference score.

3. The Standard Report provides the user with a comprehensive summary of human performance data with the option of specifying that only unusually large or unusually small scores be reported.

Long report. The Long Report provides performance data for each scenario performed by a student within a data collection session. The Long Report first separates performance data by student. For each student, the data is further separated by scenario (i.e., scenario 1, 2, 3, or 4), by version (i.e., hot or cold), and finally by scenario function (see Figure 7). For each scenario function the Long Report will provide the following data:

1. Raw data, class averages, and standard deviations for the number of keystrokes, performance time required, and number of error screens are given.

2. Differences between the student score and the class average for each of the three performance measures are calculated.

3. A reference score of expert performance for each of the performance measures broken down by function is presented.

In addition to the information provided per scenario function, after the last scenario function is reported the Long Report will provide the following summaries for all the functions in the scenario:

1. Total keystrokes and time required, the total number of error screens, and the class average score for the entire scenario are given.

2. The difference between the overall scenario student score and the class average for each performance measure is calculated.

3. A reference score of expert scenario performance for each of the performance measures is presented.

Note that the Long Report and the Standard Report provide class averages and standard deviations. The user is advised that these measures will decrease in meaning as the number of data elements decrease. If these reports are run with 5 or fewer students, these statistics should be disregarded.

LONG REPORT

SCENARIO MODE: 1
COLD VERSION

=====

IFCST #: K0524101

FUNCTION NAME: Net Address

	Student	C. Ave.	Std. Dev.	St.- Ave.	Exp. Ref.
Keystrokes:	29	28.00	1.41	1.00	29
Perf. Time:	58	59.00	1.41	-1.00	53
Errors:	0	0.00	0.00	0.00	0

FUNCTION NAME: Setup and Information

	Student	C. Ave.	Std. Dev.	St.- Ave.	Exp. Ref.
Keystrokes:	5	4.00	1.41	1.00	3
Perf. Time:	9	10.50	2.12	-1.50	13
Errors:	0	0.00	0.00	0.00	0

FUNCTION NAME: Initialization Checks

	Student	C. Ave.	Std. Dev.	St.- Ave.	Exp. Ref.
Keystrokes:	1	1.00	0.00	0.00	0
Perf. Time:	7	10.50	4.95	-3.50	0
Errors:	0	0.00	0.00	0.00	0

FUNCTION NAME: BCS Data Transfer

	Student	C. Ave.	Std. Dev.	St.- Ave.	Exp. Ref.
Keystrokes:	9	9.00	0.00	0.00	11
Perf. Time:	12	12.00	0.00	0.00	17
Errors:	0	0.00	0.00	0.00	0

FUNCTION NAME: Navigation Subsystem Restart

	Student	C. Ave.	Std. Dev.	St.- Ave.	Exp. Ref.
Keystrokes:	19	21.00	2.83	-2.00	33
Perf. Time:	50	66.50	23.33	-16.50	61
Errors:	0	0.50	0.71	-0.50	0

FUNCTION NAME: Ammo Inventory

	Student	C. Ave.	Std. Dev.	St.- Ave.	Exp. Ref.
Keystrokes:	146	141.00	7.07	5.00	155
Perf. Time:	414	468.00	76.37	-54.00	322
Errors:	0	0.00	0.00	0.00	0

Figure 7. Sample Format of the Long Report.

FUNCTION NAME: Propellant Temperature					
	Student	C. Ave.	Std. Dev.	St.- Ave.	Exp. Ref.
Keystrokes:	7	7.50	0.71	-0.50	8
Perf. Time:	10	10.00	0.00	0.00	15
Errors:	0	0.00	0.00	0.00	0
FUNCTION NAME: Set Date / Time Group					
	Student	C. Ave.	Std. Dev.	St.- Ave.	Exp. Ref.
Keystrokes:	15	23.50	12.02	-8.50	19
Perf. Time:	65	81.50	23.33	-16.50	43
Errors:	0	0.50	0.71	-0.50	0
FUNCTION NAME: Tube Load Elevation					
	Student	C. Ave.	Std. Dev.	St.- Ave.	Exp. Ref.
Keystrokes:	5	5.50	0.71	-0.50	9
Perf. Time:	7	10.00	4.24	-3.00	14
Errors:	0	0.00	0.00	0.00	0
FUNCTION NAME: Sector of Fire					
	Student	C. Ave.	Std. Dev.	St.- Ave.	Exp. Ref.
Keystrokes:	3	3.50	0.71	-0.50	5
Perf. Time:	9	10.50	2.12	-1.50	11
Errors:	0	0.00	0.00	0.00	0
FUNCTION NAME: Verify Ammo Information					
	Student	C. Ave.	Std. Dev.	St.- Ave.	Exp. Ref.
Keystrokes:	14	14.00	0.00	0.00	27
Perf. Time:	39	48.50	13.44	-9.50	68
Errors:	0	0.00	0.00	0.00	0
FUNCTION NAME: Await EOM Information					
	Student	C. Ave.	Std. Dev.	St.- Ave.	Exp. Ref.
Keystrokes:	0	0.00	0.00	0.00	35
Perf. Time:	295	293.00	2.83	2.00	309
Errors:	0	0.00	0.00	0.00	0
FUNCTION NAME: Time on Target Response					
	Student	C. Ave.	Std. Dev.	St.- Ave.	Exp. Ref.
Keystrokes:	3	3.50	0.71	-0.50	3
Perf. Time:	9	11.00	2.83	-2.00	9
Errors:	0	0.00	0.00	0.00	0

Figure 7. Sample Format of the Long Report (continued).

FUNCTION NAME: Setup Information					
	Student	C. Ave.	Std. Dev.	St.- Ave.	Exp. Ref.
Keystrokes:	2	1.50	0.71	0.50	32
Perf. Time:	199	198.50	0.71	0.50	395
Errors:	0	0.00	0.00	0.00	0
FUNCTION NAME: Emplacement Information					
	Student	C. Ave.	Std. Dev.	St.- Ave.	Exp. Ref.
Keystrokes:	69	66.50	3.54	2.50	75
Perf. Time:	109	142.00	46.67	-33.00	115
Errors:	0	0.00	0.00	0.00	0
FUNCTION NAME: Section in Order Information					
	Student	C. Ave.	Std. Dev.	St.- Ave.	Exp. Ref.
Keystrokes:	13	11.50	2.12	1.50	14
Perf. Time:	410	396.50	19.09	13.50	261
Errors:	0	0.00	0.00	0.00	0
FUNCTION NAME: Fire Mission Recive Confirm					
	Student	C. Ave.	Std. Dev.	St.- Ave.	Exp. Ref.
Keystrokes:	4	4.00	0.00	0.00	9
Perf. Time:	8	10.00	2.83	-2.00	12
Errors:	0	0.00	0.00	0.00	0
FUNCTION NAME: Fire Mission is Executed					
	Student	C. Ave.	Std. Dev.	St.- Ave.	Exp. Ref.
Keystrokes:	82	78.00	5.66	4.00	83
Perf. Time:	522	565.00	60.81	-43.00	499
Errors:	2	1.50	0.71	0.50	0

Totals for IFCST: K0524101				
	Student	C. Ave.	St. - Ave.	
Keystrokes:	426	423.00	3.00	
Perf. Time:	2232	2403.00	-171.00	
Errors:	2	2.50	-0.50	

Figure 7. Sample Format of the Long Report (continued).

Short Report. The purpose of the Short Report is to provide a rapid turnaround of student performance. The Short Report provides total keystrokes, total performance time, and total errors by student, by scenario performed, and by each student within a data collection session (see Figure 8).

SHORT REPORT

SCENARIO MODE: 1
COLD VERSION

Totals for: A0109185				
	Student	C. Ave.	St. - Ave.	Exp. Ref.
Keystrokes:	271	474.00	- 203.00	571
Perf. Time:	1892	2756.00	- 864.00	2258
Errors:	2	3.25	1.25	0
Totals for: A1204091				
	Student	C. Ave.	St. - Ave.	Exp. Ref.
Keystrokes:	571	474.00	97.00	571
Perf. Time:	2258	2756.00	- 498.00	2258
Errors:	0	3.25	3.25	0
Totals for: A1218222				
	Student	C. Ave.	St. - Ave.	Exp. Ref.
Keystrokes:	435	474.00	- 39.00	571
Perf. Time:	2455	2756.00	- 301.00	2258
Errors:	3	3.25	0.25	0
Totals for: P1201091				
	Student	C. Ave.	St. - Ave.	Exp. Ref.
Keystrokes:	619	474.00	145.00	571
Perf. Time:	4419	2756.00	1663.00	2258
Errors:	8	3.25	-4.75	0

Figure 8. Sample Format of the Short Report.

Standard Report. The Standard Report is identical to the Long Report in terms of the data it contains and its format (see Figure 9). The difference between the Standard Report and the Long Report is that the Standard Report lets the user select only extreme scores for the report. In this way, researchers can focus attention on scores that are unusually high or low. For a given performance measure, the mechanism for selecting extreme

STANDARD REPORT

SCENARIO MODE: 1
COLD VERSION

IFCST #: K0524101

FUNCTION NAME: Verify Ammo Information

	Student	C. Ave.	Std. Dev.	St.- Ave.	Exp. Ref.
Keystrokes:	14	14.00	0.00	13.00	27
Perf. Time:	39	48.50	13.44	-9.50	68
Errors:	0	0.00	0.00	0.00	0

FUNCTION NAME: Await EOM Information

	Student	C. Ave.	Std. Dev.	St.- Ave.	Exp. Ref.
Keystrokes:	0	0.00	0.00	0.00	35
Perf. Time:	295	293.00	2.83	2.00	309
Errors:	0	0.00	0.00	0.00	0

FUNCTION NAME: Section in Order Information

	Student	C. Ave.	Std. Dev.	St.- Ave.	Exp. Ref.
Keystrokes:	13	11.50	2.12	1.50	14
Perf. Time:	410	396.50	19.09	13.50	261
Errors:	0	0.00	0.00	0.00	0

FUNCTION NAME: Fire Mission Recive Comfirm

	Student	C. Ave.	Std. Dev.	St.- Ave.	Exp. Ref.
Keystrokes:	4	4.00	0.00	3.00	9
Perf. Time:	8	10.00	2.83	-2.00	12
Errors:	0	0.00	0.00	0.00	0

FUNCTION NAME: Fire Mission is Executed

	Student	C. Ave.	Std. Dev.	St.- Ave.	Exp. Ref.
Keystrokes:	82	78.00	5.66	4.00	83
Perf. Time:	522	565.00	60.81	-43.00	499
Errors:	2	0.11	0.05	1.89	0

Totals for IFCST: K0524101

	Student	C. Ave.	St. - Ave.
Keystrokes:	426	423.00	3.00
Perf. Time:	2232	2403.00	-171.00
Errors:	2	2.50	-0.50

Figure 9. Sample Format of the Standard Report.

scores is to subtract the student score from the class average and divide the result by the standard deviation of the class scores. The criteria level for this selection may be selected by the user (i.e., from 0.5 to 3.0). For example, if the criteria value of 2.0 was chosen, the formula would be:

$$(\text{Student Score} - \text{Class Average}) / \text{Standard Deviation} \geq 2 .$$

IFCST-Related Administrative Requirements

Data Collection Administrative Requirements

As described above, the IFCST DCS files of individual student data correspond to the letter of the IFCST unit on which the data was taken. The letter designation actually arises from the port on the multi-serial controller card installed in the data collection microcomputer into which the IFCST is connected. The IFCST letter designation (i.e., A-R for up to 18 IFCST units) becomes part of the file name for a student performance data file. The remaining part of the data file name is the month, day, and time that the data was collected. Because the IFCST DCS does not refer to individual students by name, it is recommended that a dated record of student names and their corresponding IFCST be kept (e.g., John Doe - IFCST A and John Smith - IFCST B).

After the IFCST DCS is connected to the 18 IFCST units, it is suggested that a mock data session be conducted to initiate the data collection software. The data collection supervisor and an assistant should turn on each IFCST individually as the data collection software is running and observe the letter designation that appears on the data collection microcomputer monitor. After this, each IFCST unit can be labeled with the appropriate letter (A-R). This list should be provided to the researcher involved with the IFCST DCS. After the IFCSTs have been labeled with their appropriate letters, care should be taken not to switch any of their cables to other ports in the multi-serial port data communications controller card of the data collection microcomputer. If this occurs, the wrong data will be associated with student names. The data collection supervisor should periodically check the connections to the IFCSTs and the corresponding letter designations to ensure their accuracy.

Under normal circumstances, the IFCST DCS will require minimal supervision. The data collection supervisor need only activate the software at the onset of the data collection session and then press the Esc key at the end of the session. It is necessary, however, to take some steps to ensure that the data collection software is able to perform properly. Due to an eccentric characteristic of the software that drives the IFCST simulator and the fact that the source code could not be modified to support data collection, the only way for the IFCST DCS data

collection software to recognize what scenario is being performed (i.e., 1-4) is for the student to select the manual ammunition option on the SIU prior to running the scenario. Note that the selection of one of the two options (i.e., manual or automatic) is always made prior to running a scenario. When the manual selection option is made on the SIU, the IFCST echoes the scenario version being run through serial port #2 and this information is recorded by the IFCST DCS on the student performance data file. If manual selection is not chosen, the scenario version will be "5" in the data file, regardless of which scenario was run.

It is also recommended that a certain procedure be followed for instances in which the IFCST scenario software "locks up" or crashes while a student is performing a scenario. The IFCST DCS will allow for a scenario to be restarted at the point of the "crash" with no impact on the performance measures being recorded by the system as long as the following procedure is followed. The student must turn the DCU off, then turn the DCU back on again. When this is done, the scenario will restart at the point of the last function that was being performed. During this restart process or at any other time, the student must not turn the SIU off. If the SIU is turned off at any time during a data collection session, all of the data that was recorded up to that point will be lost.

Care must also be taken to ensure that a student does not perform the same scenario two or more times within a data collection session. If this occurs, the performance data will be added for each function of the multiple scenario runs. This will cause the performance measures to be doubled or even tripled depending on how many times the same scenario is run. Obviously, this data would be an invalid assessment of the student's performance and would alter class averages and standard deviations for that scenario.

A final consideration is the impact of collecting data for both hot and cold scenario versions. If the researcher desires to decrease the number of students for each measure that are averaged separately in the summary report preparation (i.e., there could be a maximum of 8 separate class averages from hot and cold versions of the 4 scenarios), then students should run only cold versions of scenarios. This would reduce the maximum number of "group" scores from 8 to 4. Therefore, the data collection supervisor must make sure that each student runs a cold version of the scenario by turning the DCU off and then back on between scenarios. Note that the SIU must not be turned off at any time or all of the previous data collected will be lost.

Data File Administrative Requirements

Data base files and file structure. The dBASE IV data files which store the IFCST performance data are structured to provide sufficient contextual and identifying information for easily evaluating and reporting the data. There are two dBASE IV data files used in IFCST Data base, EXPERT.DBF containing expert performance data and TODAY_RE.DBF containing student performance data.

The EXPERT.DBF file is used to compare student performance data with expert performance data. Specifically, it contains data for an expert user of the system for each of the scenarios (i.e., from an individual who was very familiar with the IFCST and the scenarios). The TODAY_RE.DBF file is a repository for all human performance data collected by the IFCST DCS.

The structure of these two files is quite similar because they must contain the same data elements. The only exceptions are that the TODAY_RE.DBF file includes a field for the name of the data file and the EXPERT.DBF uses the first three fields as index files for data reporting purposes.

The data structure of the two data files is defined as follows:

TODAY_RE.DBF

<u>Field</u>	<u>Field Name</u>	<u>Type</u>	<u>Width</u>	<u>Index</u>
1	NAME	Character	8	N
2	SCENARIO	Numeric	1	N
3	VERSION	Numeric	1	N
4	FUNCTION	Character	30	N
5	TIME	Character	4	N
6	KEY	Character	3	N
7	WARN	Character	2	N

EXPERT.DBF

<u>Field</u>	<u>Field Name</u>	<u>Type</u>	<u>Width</u>	<u>Index</u>
1	SCENARIO	Numeric	1	N
2	VERSION	Numeric	1	N
3	FUNCTION	Character	30	N
4	TIME	Character	4	N
5	KEY	Character	3	N
6	WARN	Character	2	N

The IFCST DCS Data Base Concept

The data base in the IFCST DCS is not stored permanently on dBASE IV data files. The data resides in the coded data files described earlier. This allows for large amounts of data to be stored in less disk space than dBASE IV files, without limiting access to any of the data in dBASE IV format.

Working with Human Performance Data in dBASE IV

The procedures used to review and modify data in dBASE IV format are the same as the procedures described for specifying report data in the "Exporting Data to Print from a Separate Microcomputer" and "Selecting and Printing Reports" sections of this report. After the user has specified the coded data files of interest and has proceeded to the Report screen, the user selects the "Quit" option. The specified data is now in TODAY_RE.EXE in dBASE IV format. This file may be manipulated with dBASE IV as desired.

The data in TODAY_RE.DBF may be edited as required and then reported with the EXREPORT.EXE file as long as the name (i.e., EXREPORT.EXE) of the file has not been changed and the structure of the data file has not been altered (e.g., names, size, or number of fields). The TODAY_RE.DBF may be broken down into smaller files of specific interest, any of which may be printed with the EXREPORT.EXE, by changing the name of the file to be printed to TODAY_RE.DBF.

Appendix A

DESCRIPTIONS OF DECISIONS REGARDING ANCILLARY COS TASKS AND SOURCE CODE

COS Tasks

The original delivery order stated that software and hardware requirements be identified and developed for coarsely representing and simultaneously superimposing non-AFCS-related COS tasks during the "test" scenario used in the IFCST data collection. COS tasks which do not specifically involve the AFCS and are not simulated by the IFCST include tasks such as radio communication, navigation, decision making, maintaining accurate ammunition counts, and crew interaction and supervision. These tasks were to be cued by playing taped prompts associated with certain COS tasks to each student in the IFCST class over individual headsets, and recording their responses on a multi-channel tape recorder. Their responses would later be evaluated by experts and rating scores entered into the IFCST performance data base for each student.

Therefore, a meeting was conducted with experts on Paladin and IFCST operations at Fort Sill to discuss this process and identify candidate tasks. From these meetings, it was concluded that the overlay of ancillary COS tasks was not appropriate for the IFCST simulation process, due to the fact that individuals proceed through the scenarios at different rates on the IFCST depending on their ability and knowledge of the system (i.e., performance times for a given scenario may be as short as 30 minutes or as long as an hour or more). Thus, there is no practical way to control for these differences. In other words, differences as small as a few seconds could cause two individuals to be performing two entirely different IFCST scenario functions at any given time. This impacts the feasibility of appropriately introducing COS task measures for two reasons:

1. The COS task-related and IFCST-related data would show large random fluctuations due to the COS task cues occurring during high workload functions for some students and low workload situations for others.

2. During some scenario functions such as "fire" sequences, it would be inappropriate to respond to COS tasks, and again, there would be no way to ensure that none of the students were performing such a function when the COS task cue was provided.

Consequently, the COS task-related data would be difficult to interpret under these conditions and would be of little or no value in evaluating student proficiency on these tasks. The IFCST data would also be confounded by the ancillary COS tasks, reducing the validity of conclusions drawn from the performance

data.

For these reasons, the requirement was re-evaluated by the Army Research Institute (ARI), and it was decided that efforts would be directed instead into the inclusion of data from all four of the scenarios in the IFCST DCS.

Source Code

A major factor present in the initial phases of the project which impacted the planning of all project activities and particularly the specification of hardware and software required to support the development of the IFCST DCS was the source code that drives the IFCST scenarios. Immediately following the delivery of the IFCST unit, the source code to the IFCST software was requested. This request was made because the data capture requirements as originally specified in the delivery order focused on a very fine level of detail (i.e., time and accuracy per individual keystroke entry). Obtaining data at this level of detail is possible only if the source code of the IFCST is altered so that each input performed by the student is accurately identified by the system, and so that enough contextual information is provided to allow for each keystroke to be evaluated in terms of time and error.

Initial Data Collection Strategy

The IFCST in its present configuration does not allow for data to be collected per scenario function. As the system is being operated (i.e., a scenario is being run), certain information pertaining to the operation of the system is echoed through serial port #2 in the back of the IFCST. Connecting this port to a computer will allow for this information to be read. Although individual numerical and other entries made by the student are only echoed through the port as "XX", each time a new screen associated with a separate scenario function appears on the SIU monitor, the identification of this screen (and therefore function) is echoed. In addition, each time a student attempts to enter erroneous data at the conclusion of a function, an error screen appears. The identification of this error screen is also echoed. This feature of the IFCST allows keystrokes to be counted (i.e., the number of "XX"s) and for time of performance to be measured via program code designed for this purpose and the internal clock of the data collection computer, and for attempted input of erroneous data according to the number of error screens for each scenario function.

Revised Data Collection Strategy

After several unsuccessful attempts by the contractor and the ARI to secure the source code, a decision was made to proceed with the IFCST DCS without the code. Therefore, the IFCST DCS

was developed to measure performance by scenario function rather than individual keystroke, that is, by keying the data collection software on the features of the IFCST described above. The data obtained per function by the system as it exists are extensive. Thus, individual keystroke level data would have been extremely cumbersome to handle by even a very fast microcomputer in terms of the processing time for data reduction and summary reports, and the resulting data would likely be of a depth of detail that would have provided little if any advantage to users of the system.

Appendix B

IFCST DCS EQUIPMENT

This appendix describes the hardware components of the IFCST DCS, how they are connected, and other information that will help the user in setting up and understanding the system. The IFCST DCS includes the following hardware components:

1. 80386 IBM compatible microcomputer with 33 MHz clock speed, 120 Megabyte hard disk, one 5.25 inch floppy drive, one 3.25 inch floppy drive, keyboard, and color monitor.
2. Three 8-port multi serial port data communication controller cards.
3. Twenty, 50 foot 8-wire phone cables.
4. Three RS232-to-8 wire adapters.
5. Two external Bernoulli drives with 44 Megabyte cartridges.

The 80386 IBM compatible microcomputer is used to collect and store data from the IFCST units. The software controlling data collection resides on the unit's hard drive.

The three 8-port multi-serial port data communication controller cards are installed in the microcomputer. These cards are installed in a standard fashion as any serial card would be installed. On the back of each card is an array of 8 ports to connect the 8-wire cables. These three sets of 8 ports include the 18 ports required to interface with the 18 IFCST units.

Each IFCST port is designated by a letter. The letters begin at the lowest card and proceed from right to left and include all eight ports of the first two cards and two of the third card. The letters corresponding to these ports begin at A and end at R (see Figure B-1).

The 18, 8-wire serial communication cables are connected to these ports on the microcomputer. The other end is connected to the RS232-to-8-wire adapters (see Figure B-2) and then connected to each of the 18 IFCST units. The adaptor end must be connected to the serial port #2 port on the back of the IFCST units.

There were three adapters provided by the Army, 13 more are required to accommodate all 18 IFCST connections to the microcomputer. These adapters may be purchased from an electrical supply outlet for approximately \$4 apiece - disassembled. The adapters must be customized to operate correctly with the system.

It is necessary to wire the adapters to interface with the 8-wire communication cables as per the wiring diagram in Figure B-3.

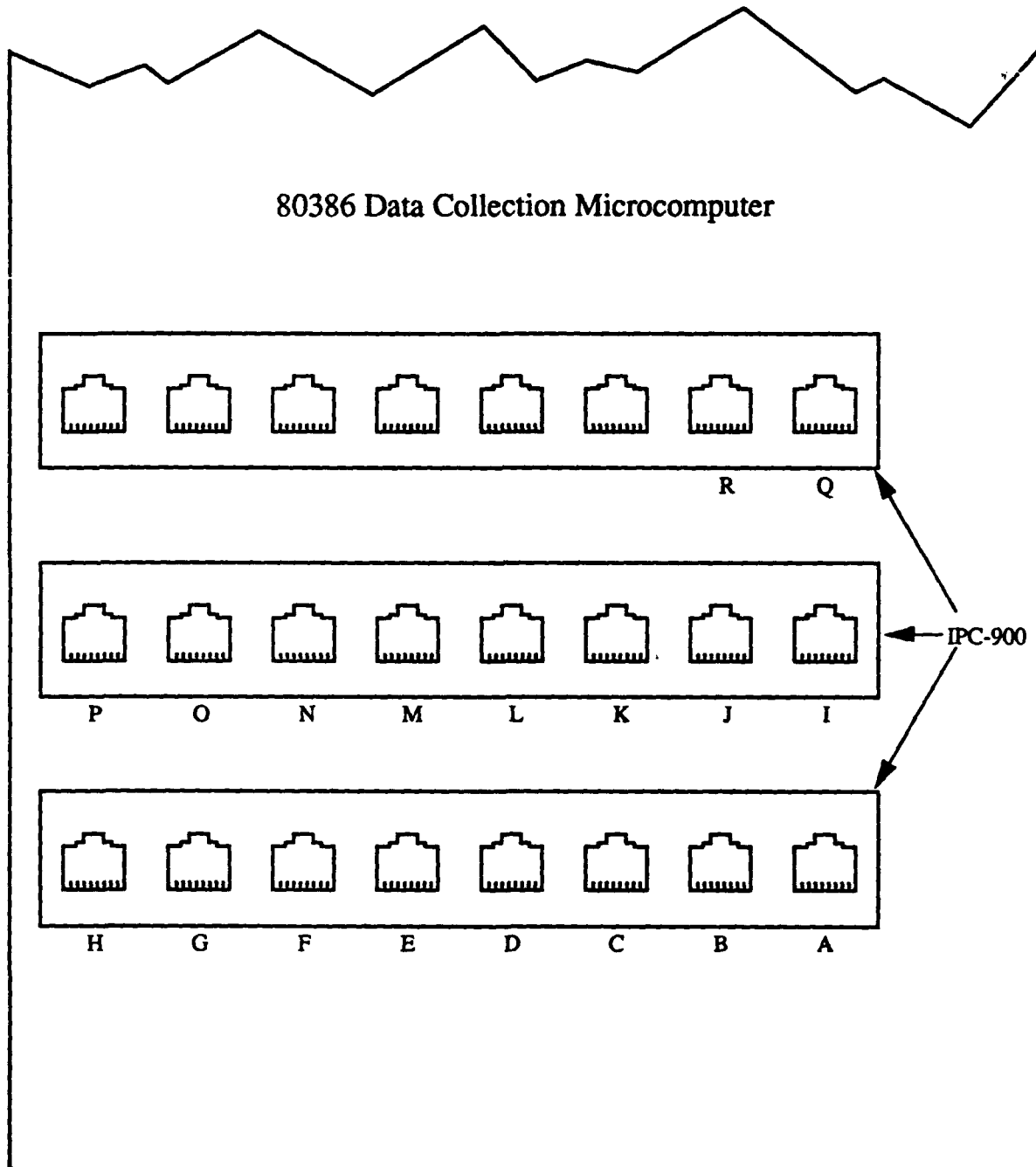

Figure B-1. Multi-serial Port Controller Cards as installed showing port letter designation.

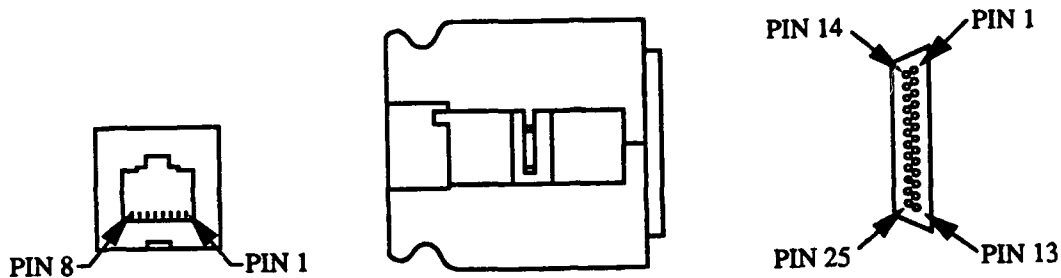

Figure B-2. RS-232-to-8-Wire adaptor.

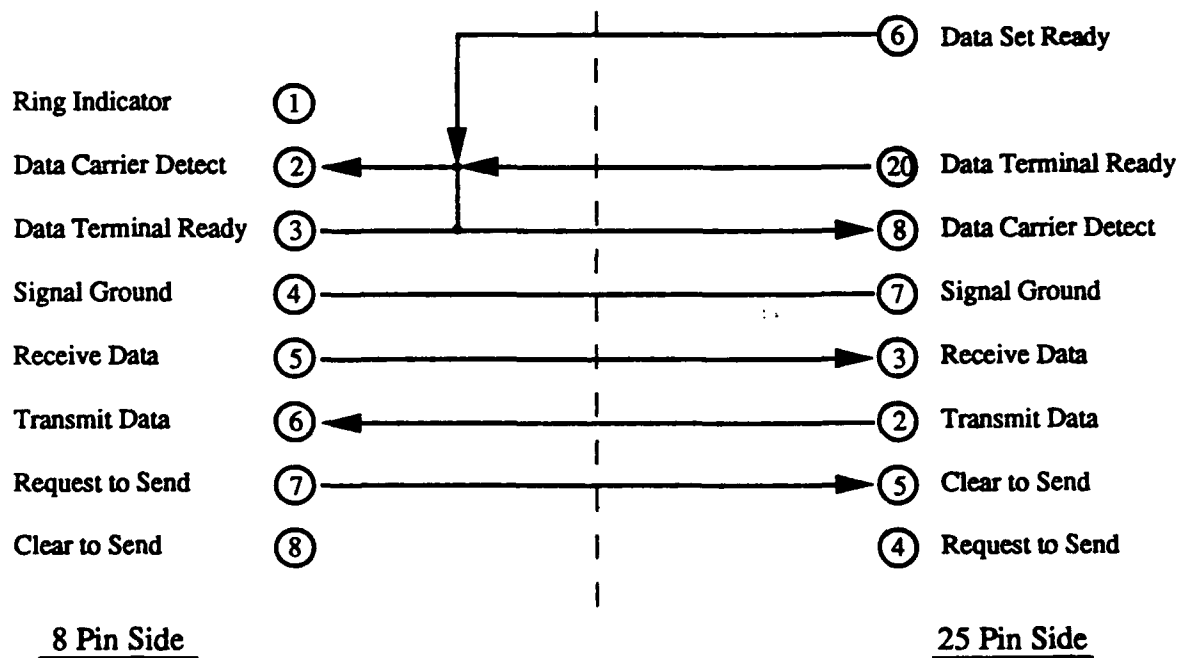

Figure B-3. RS-232-to-8-Wire adaptor wiring diagram.

The Bernoulli drives were planned to provide a rapid and efficient method for moving large amounts of data from the data collection microcomputer to another microcomputer for reporting or conducting other analyses. It is suggested that data collection and storage be performed from the hard drive of the data collection microcomputer, and after the data collection has been completed, the data should be copied to a bernoulli cartridge.

Appendix C

ABBREVIATIONS AND ACRONYMS

13B30s	Military Occupational Specialty designator for cannon crew member skill level three soldiers
AFCS	Automatic Fire Control Computer System
ARI	Army Research Institute
COS	Chief-of-Section
DCS	Data Collection System
DCU	Display Control Unit
IFCST	Institutional Fire Control System Trainer
MHz	Megahertz
Paladin	M109A6 Howitzer
SIU	Student Interactive Unit
TRADOC	United States Army Training and Doctrine Command
USAFAS	United States Army Field Artillery School