

AD-A253 247



RL TR-91-437
Final Technical Report
December 1991



ARCHITECTURE AND DEVICE DEVELOPMENT FOR OPTICAL NETWORKS

Princeton University

Paul R. Prucnal (Princeton University)
John L. Stacy, Mark F. Krol, Raymond K. Boncek,
Steven T. Johns (Rome Laboratory)



APPROVED FOR PUBLIC RELEASE; DISTRIBUTION UNLIMITED.

92-20233



Rome Laboratory
Air Force Systems Command
Griffiss Air Force Base, NY 13441-5700

This report has been reviewed by the Rome Laboratory Public Affairs Office (PA) and is releasable to the National Technical Information Service (NTIS). At NTIS it will be releasable to the general public, including foreign nations.

RL-TR-91-437 has been reviewed and is approved for publication.

APPROVED:

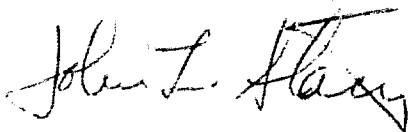

JOHN L. STACY
Project Engineer

FOR THE COMMANDER:

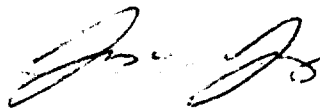

JAMES W. YOUNGBERG, Lt Col, USAF⁴
Deputy Director
Surveillance and Photonics Directorate

If your address has changed or if you wish to be removed from the Rome Laboratory mailing list, or if the addressee is no longer employed by your organization, please notify RL(OCPA) Griffiss AFB, NY 13441-5700. This will assist us in maintaining a current mailing list.

Do not return copies of this report unless contractual obligations or notices on a specific document require that it be returned.

REPORT DOCUMENTATION PAGE

Form Approved
OMB No. 0704-0188

Public reporting burden for this collection of information is estimated to average 1 hour per response, including the time for reviewing instructions, searching existing data sources, gathering and maintaining the data needed, and completing and reviewing the collection of information. Send comments regarding this burden estimate or any other aspect of this collection of information, including suggestions for reducing this burden, to Washington Headquarters Service, Directorate for Information Operations and Reports, 1215 Jefferson Davis Highway, Suite 1204, Arlington, VA 22202-4302, and to the Office of Management and Budget, Paperwork Reduction Project (0704-0188), Washington, DC 20503.

1. AGENCY USE ONLY (Leave Blank)	2. REPORT DATE December 1991	3. REPORT TYPE AND DATES COVERED Final Mar 90 - Mar 91	
4. TITLE AND SUBTITLE ARCHITECTURE AND DEVICE DEVELOPMENT FOR OPTICAL NETWORKS		5. FUNDING NUMBERS C - F30602-88-D-0026, Task P-0-6015 PE - 62702F PR - 4600 TA - P2 WU - P6	
6. AUTHOR(S) Paul R. Prucnal (Princeton University), John L. Stacy, Mark F. Krol, Raymond K. Boncek, Steven T. Johns (Rome Laboratory)		8. PERFORMING ORGANIZATION REPORT NUMBER N/A	
7. PERFORMING ORGANIZATION NAME(S) AND ADDRESS(ES) Princeton University Princeton NJ 08544		10. SPONSORING/MONITORING AGENCY REPORT NUMBER RL-TR-91-437	
9. SPONSORING/MONITORING AGENCY NAME(S) AND ADDRESS(ES) Rome Laboratory (OCA) Griffiss AFB NY 13441-5700		11. SUPPLEMENTARY NOTES Rome Laboratory Project Engineer: John Stacy/OCA/(315) 330-2937 Prime Contractor: Calspan-UB Research Center P O Box 400 Buffalo NY 14225	
12a. DISTRIBUTION/AVAILABILITY STATEMENT Approved for public release; distribution unlimited.		12b. DISTRIBUTION CODE	
13. ABSTRACT (Maximum 200 words) This report describes the work accomplished at the Photonics Center, Rome Laboratory in developing an Optical Time Division Multiaccess coder capable of rapidly shifting an optical pulse in time for address recognition. It also describes current and future work being accomplished at the Photonics Center on coincidence detection ('AND' gate) for use in demultiplexing channel information from a multi-gigabit data stream. Part of this effort, dealing with the free-space switching architecture, was primarily accomplished at Princeton University.			
14. SUBJECT TERMS Optical Communication, Optical Interconnects, Optical Networks		15. NUMBER OF PAGES 40	
		16. PRICE CODE	
17. SECURITY CLASSIFICATION OF REPORT UNCLASSIFIED	18. SECURITY CLASSIFICATION OF THIS PAGE UNCLASSIFIED	19. SECURITY CLASSIFICATION OF ABSTRACT UNCLASSIFIED	20. LIMITATION OF ABSTRACT UL

ACKNOWLEDGEMENTS

This report is the result of collaborative work accomplished by the Rome Laboratory Photonics Center under in-house research project 4600P201 and the Advanced Technology Center at Princeton University under Rome Laboratory contract number F30602-88-D-0026-0031.

The project was conceived and initiated by Rome Laboratory personnel. John L. Stacy, Mark F. Krol, Raymond K. Boncek and Steven T. Johns were the Rome Laboratory personnel involved in the effort. Dr Paul R. Prucnal from Princeton University was also involved in this effort.

Dr Prucnal worked with Rome Laboratory Engineers in designing several projects involved in the effort. Included in this was the Free Space Switch experiment, Coder experiment and the "AND" gate experiment. All of the experimental work for the Coder experiment and the AND gate experiment was accomplished at the Rome Laboratory Photonics Center. The experimental work for the Free Space Switch experiment was accomplished at Princeton University with the assistance of Rome Laboratory personnel. Analysis of the data and the writing of several papers as a result of this work was a combined effort.

We wish to thank E. Desurvire and B. Tell of AT&T Labs for providing the photoconductive "AND" gates and J. Rosetti and J. Maurice of the Photonics Center for supplying the directional coupler switches.

Table of Contents

1. Introduction
2. Free-Space Optical TDM Switch
 - 2.1 Development of a Free-Space TDM System
 - 2.2 System Configuration
 - 2.3 Experimental Setup
3. Time-Division Demultiplexing
 - 3.1 AND Gate Operation
 - 3.2 AND Gate Performance
 - 3.3 Future AND Gate Experiments
4. Optical Delay Line Coder
 - 4.1 OTDM Description
 - 4.2 OTDM Coder Operational Configuration
 - 4.3 OTDM Coder Performance
5. Summary
6. References

LIST OF FIGURES

- 2.1 Time-Division Optical Cross-Connect.
- 2.2 TDM Photonic Interconnect.
- 2.3 Reference Pulse Added To Non-Active User.
- 2.4 Reference Pulse Added To Active User.
- 3.1 Experimental set-up.
- 3.2a Photoconductive gap impulse responses.
- 3.2b Response of the photoconductive gate as a function of pump/probe delay.
- 4.1 OTDM Coder.
- 4.2 Experimental Set-Up.
- 4.3 Pulse Coding.

Accession For	
NTIS GRA&I	<input checked="" type="checkbox"/>
DTIC TAB	<input type="checkbox"/>
Unannounced	<input type="checkbox"/>
Justification	
By _____	
Distribution/	
Availability Codes	
Dist	Avail and/or Special
A-1	

1. INTRODUCTION

The purpose of this work was to develop architectures and devices for optical interconnect applications. Specific accomplishments include investigation of a free space switching architecture, pulse coincidence detection (AND gate), and pulse coding for channel selection.

The applications for this work are extensive. Almost every future military system will require optical network technology (interconnects) at both the microlevel (on-chip and chip-to-chip) and the macrolevel (LANs, MANs, WANs and Gateways).

Present trends dictate that warfare of the 21st Century will require more remote surveillance and analysis of potential conflicts. Reaction times in conflict areas will shorten substantially. Intelligence and surveillance requirements for information fusion will move communications into the multi-gigabit rates to provide positive reaction within an ever decreasing time frame.

Optical technology will be the technology of choice to provide adequate answers for future military applications in time constrained situations. It will also be the technology of choice for a wide variety of other military applications such as base, site, and space communications.

The wide bandwidths associated with fiber optic communications will permit upward compatibility of existing capabilities. Examples of this would be operational clusters using

integrated services, whether military or commercial, and they will find the high performance network completely transparent to their needs and capable of providing gigabit bandwidths to individual users. Optical technology provides other unique benefits such as greater distances, reduced vulnerability to electromagnetic interference (EMI), as well as a substantial decrease in weight and volume. This last attribute makes it extremely attractive for a wide variety of space, air and vehicle applications. Security is also enhanced with fiber optic communications since optical fiber does not radiate electromagnetic fields.

2. FREE-SPACE OPTICAL TDM SWITCH

2.1 Development of a Free-Space TDM System

Optical technology offers the potential for designing large dimension switching/interconnect systems. Large dimension switches can be obtained by concatenating several stages of smaller switch modules. The disadvantages to this approach are the large insertion losses, high crosstalk and polarization sensitivity which limits the size of practical systems. Another possibility for achieving large dimensionality is to perform "logic switching" instead of "physical switching". The advantages of such systems are parallel processing, polarization and crosstalk insensitivity, and low system loss.

Recently, there has been considerable interest in designing star coupled optical cross-connects [1-4]. One possible implementation uses Frequency Division Multiplexing (FDM) technology [5,6]. However, there are technological limitations such as the tunability of DBR lasers and the high insertion loss of Fabry-Perot filters which limits the capability of realizing a large number of ports. Time Division Multiplexing (TDM) offers another possibility for the realization of a large input/output port system [7-10]. However, there are several technological issues in TDM which must be addressed to make such systems practical.

There are two possible ways to design the switch, either a fixed transmitter with a variable receiver or a variable transmitter with a fixed receiver. The first scheme has the inherent advantage of broadcast capability. However, design issues for both the schemes are the same. Other efforts for the design of TDM systems have been implemented with optical fiber [7-10]. A free space approach circumvents technical problems such as polarization sensitivity, large input/output star, and optical nonlinearities inherent in fiber based systems. A large dimension spatial light modulator [11] and star coupler [12] have already been experimentally demonstrated. This offers the possibility of a free space $N \times N$ interconnect system. However, there is still an open issue such as the development of a low-loss high-speed tunable delay line with wide tuning range and high finesse [13].

2.2 System Configuration

At present, circuit switching is used for routing telephone traffic. In this type of switching architecture a central processor checks the availability of a path. If the path is available, a connection from input to output is made. The central processor makes a dedicated physical connection between the input and output. Once a connection is made it stays there for a long period of time. Therefore, speed requirements for the processor to set up a connection can be a few milliseconds.

In a TDM circuit switching system each user is assigned a time slot of duration "t" in the time frame "T". In the ideal situation, if the system is not limited by optical power, the ratio of T/t determines the maximum possible number of input/output ports. Since each user is assigned a time slot on the frame the corresponding receiver at the output therefore looks only in the preassigned time slot for signal recovery. The electrical data signal from the input source is used to gate the optical pulses from the centralized source for the duration of the signal. Figure 2.1 shows the architecture of a free-space TDM circuit switching system with a fixed transmitter and tunable receiver assignment.

In this configuration, each signal gated by the modulator is shifted in time for a fixed time duration. The signal from each encoder is then multiplexed in time by the passive star coupler and then the composite pulse stream is broadcast to all the output

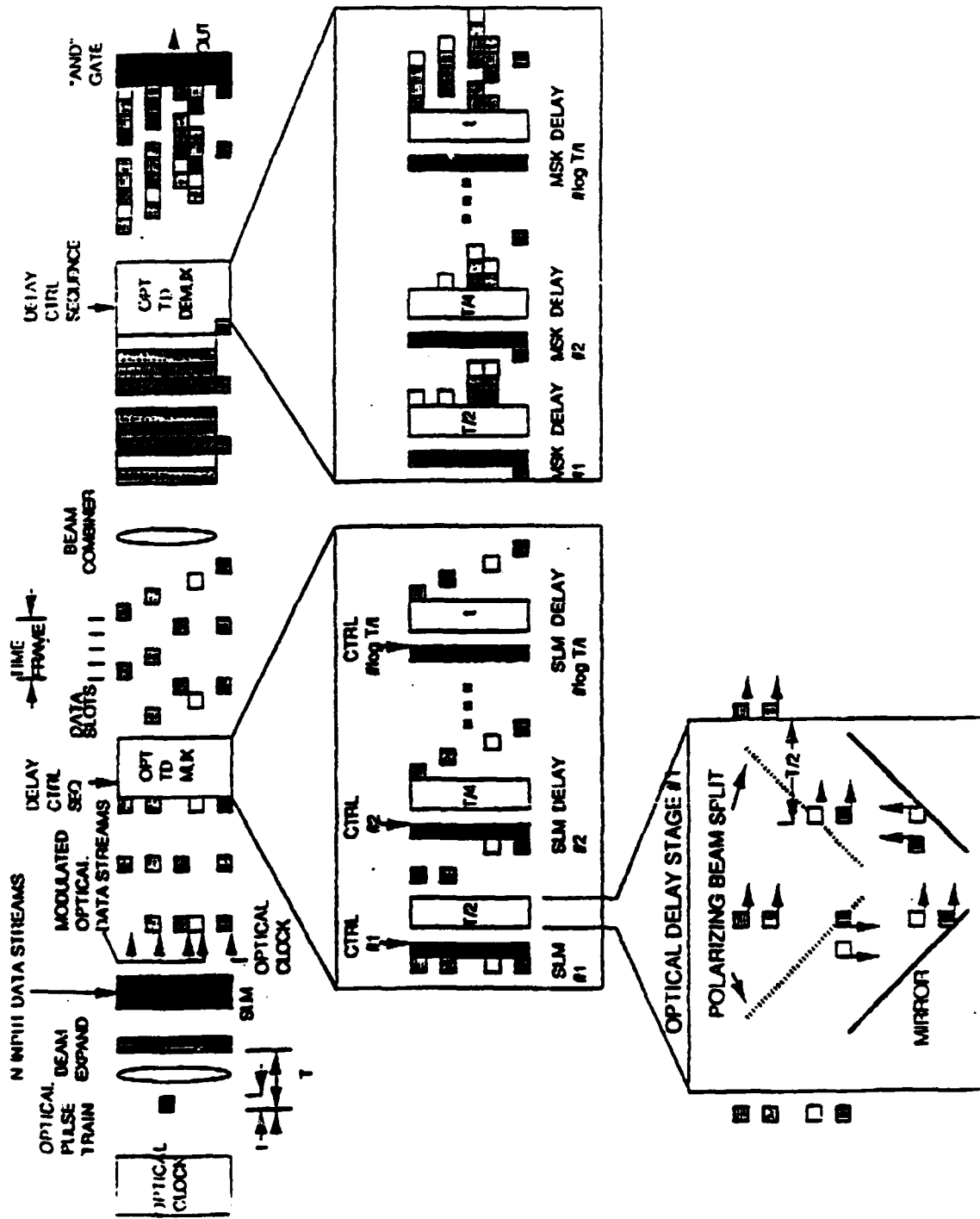

Figure 2.1 Schematic diagram of an Optical Time-Division Cross-Connect.

receivers. The receiver is tuned over the duration of the complete time frame for generation of the electrical signal. The desired output signal is demultiplexed from the pulse stream by pulse coincidence detection. The time demultiplexing is achieved by optically sampling the pulse stream with a clock signal from the time delay decoder.

In fixed receiver assignment, the gated optical signal is shifted in time depending on the destination address of the input signal selected by the time delay encoder. The decoder delays the clock signal to the time slot corresponding to the output port. One of the key components of the system is the tunable time delay system which can be tuned over the complete time frame with the resolution of a pulse duration. For the circuit switching system, moderate setup time may be sufficient. However, high finesse is necessary for a large dimension switch.

2.3 Experimental Setup

A schematic diagram of an experimental two channel TDM system is shown in Fig. 2.2. In this system an optical clock from a Nd:YLF laser (generating 100 psec pulses at a repetition rate of 100 MHz) is synchronously distributed to each optical input and output port of the switch. At each input port an SLM modulates the input optical signal by the electrical data signal. For the fixed transmitter and tunable receiver assignment system the optical

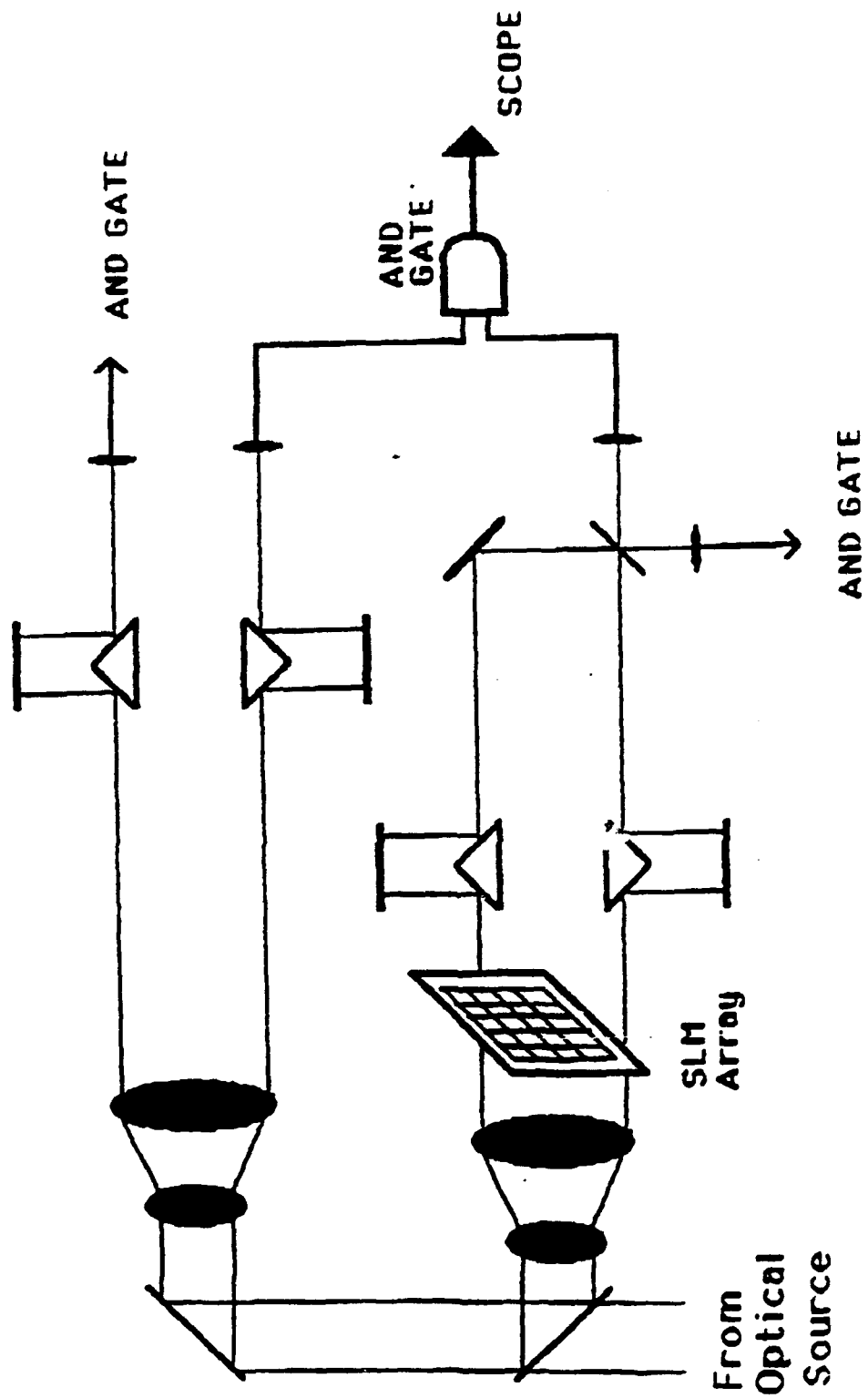

Figure 2.2 Schematic diagram of an experimental cross-connect.

signals are then moved into the desired output time slots by an appropriate time delay. The time delays at the receiver are selected by the destination address.

The experimental TDM system was constructed by expanding the beam from the YLF laser onto a 6x6 liquid crystal display device. This device is used for ON/OFF modulation of the light signal. The precise time delays are generated by free space optics. The signals, after proper delay, are mixed and broadcast to all the outputs with the help of a passive star coupler. Simple beam splitters are used for mixing and broadcasting. Each output of the star coupler carries a time multiplexed encoded signal from all of the inputs. At the output port, the time multiplexed input signal and fixed time delayed clock are incident on an optical logic AND gate [14]. Threshold logic detection is performed by the optical AND gate. The system has a fixed transmitter assignment architecture. Figure 2.3 shows the signal detected at the receiver by using pulse coincidence detection when one of two adjacent users is transmitting and the reference pulse is added to the non-active user.

Figure 2.4 shows the received signal when the non-active user in the adjacent time slot becomes an active transmitter. There is a substantial difference in the magnitude of the output at the receiver. The substantial increase in the magnitude of the signal facilitates threshold detection and signal regeneration at the output. The number of users on the system can be increased by increasing the number of time slots in a given time frame.

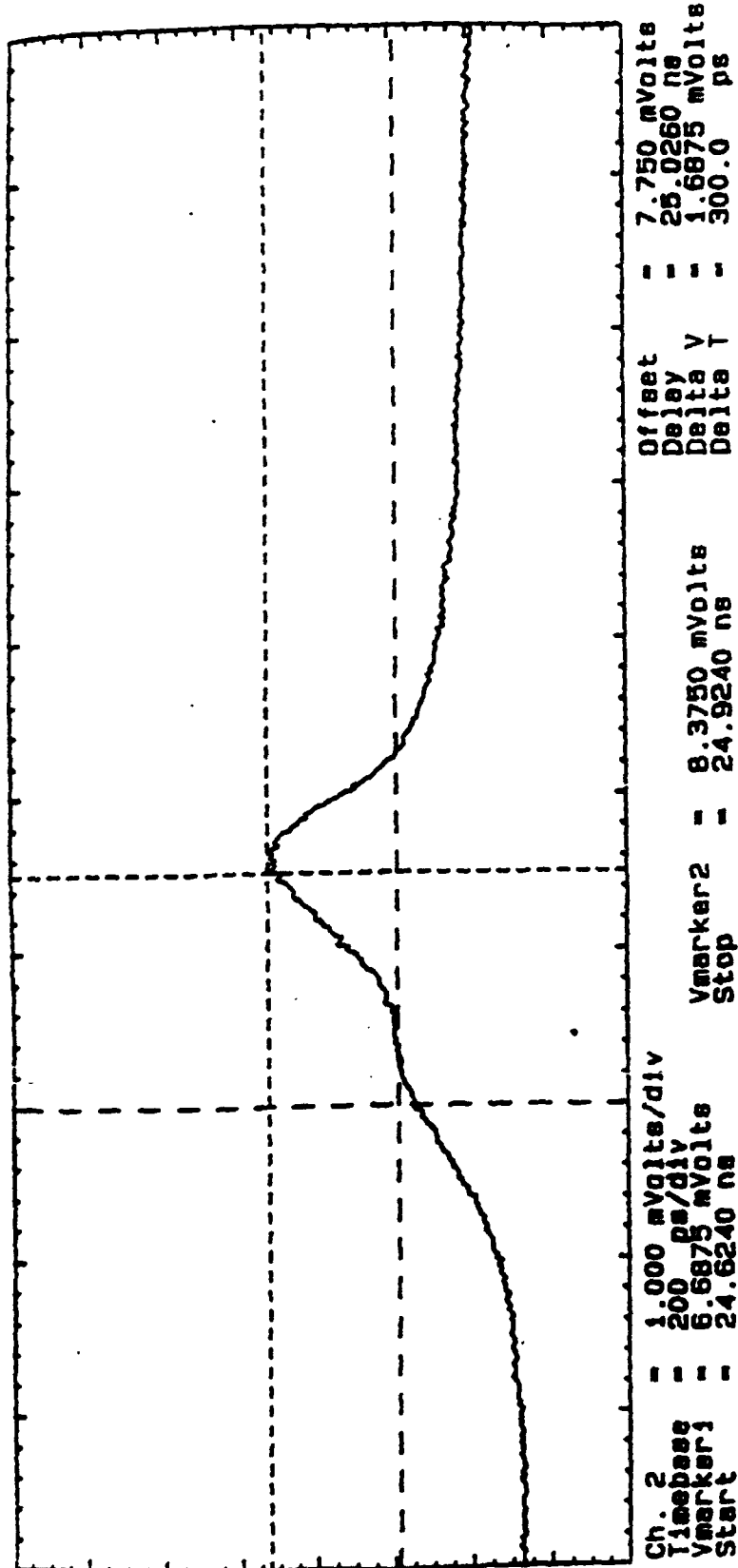

Figure 2.3 Reference pulse added to a non-active user.

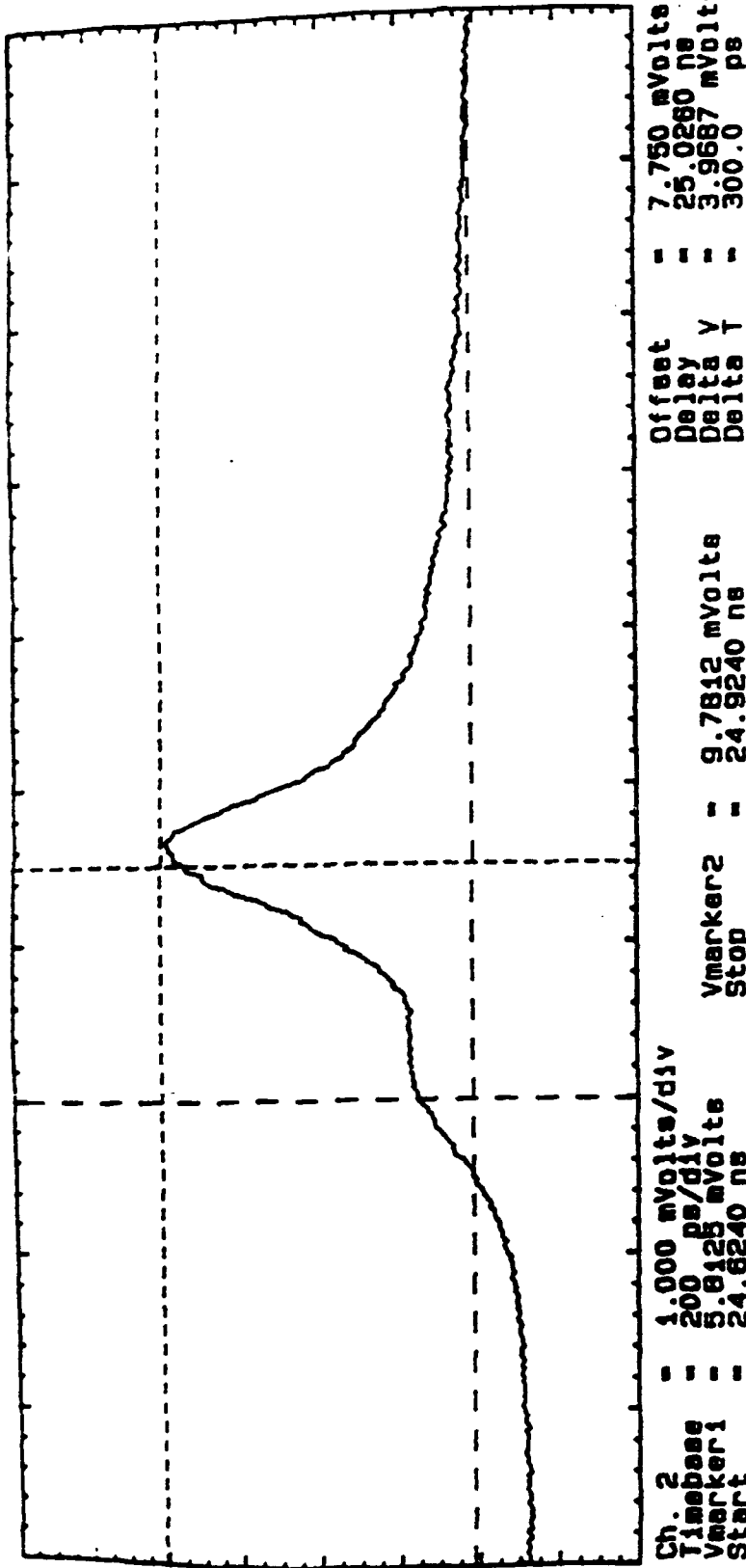

Figure 2.4 Reference pulse added to an active user.

3. TIME-DIVISION DEMULTIPLEXING

3.1 AND Gate Operation

The development of high data-rate Time Division Multiplexed (TDM) optical interconnects has created the need for high-speed demultiplexing and detection components for extracting baseband data from high-rate multiplexed data streams. One method to realize the demultiplexing is by performing a high speed AND operation between the optical clock and the multiplexed optical data stream.

Auston [15] proposed the use of two amorphous silicon photoconductive gaps in series, in which the second gap samples the electrical signal generated at the first gap, to implement an optoelectronic AND operation. This reduces the complexity of the demultiplexing circuit by combining the detection and AND operations into a single device. Auston demonstrated a photoconductive AND gate with a temporal resolution of approximately 10 ps. Recently a photoconductive InGaAs:Fe AND gate was developed by Desurvire [14], et al., which operates in the 1.3-1.5 micron wavelength region. This device consists of two 5x5 micron photoconductive areas separated by a 250 micron microstripline. A D.C. bias voltage is applied to one side of the device to produce a potential drop across the photoconductive areas which in turn allows a current to flow through the device when photons are incident on the photoconductive areas.

To determine the maximum number of users that can be accommodated on the system the photoconductive AND gate has been characterized using 2 psec optical pulses to investigate the impulse response, recovery speed and sensitivity.

3.2 AND Gate Performance

The operating characteristics of the gate were investigated using a 2 picosecond, mode locked, pulse compressed, 1.32 micron laser source. The experimental set-up used for the measurement is shown in Fig. 3.1. To determine the device impulse response and on/off ratio an experimental technique similar to time resolved pump/probe spectroscopy was performed. Figure 3.2a shows the experimentally measured impulse responses of each gap and Fig. 3.2b shows the response of the gate as a function of the time delay between the pump and probe beam.

The impulse response measurements using the 2 psec optical pulses indicate that the photoconductive gaps have FWHM responses of less than 20 psec. However, the existence of slowly-decaying, low-amplitude tails, possibly caused by surface states or defects resident at the ternary-binary interface, are the limiting factor in the operating speed of the device. This limitation was confirmed by the time-resolved, picosecond correlation measurements in which the operating speed of the device was determined to be 5 GHz. The correlation measurements also indicate that the maximum contrast ratio of the gate at pulse energies of 270 fJ was

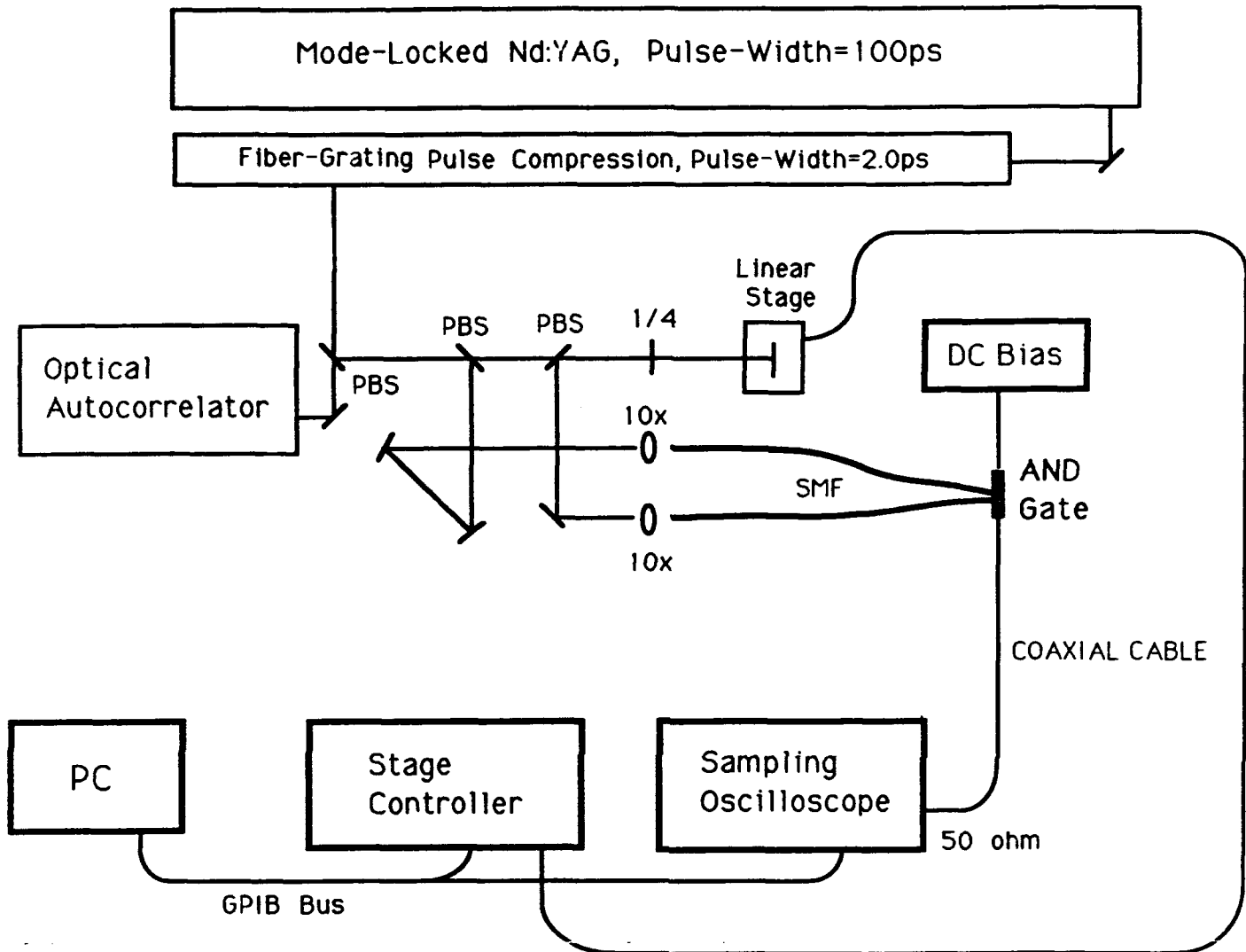
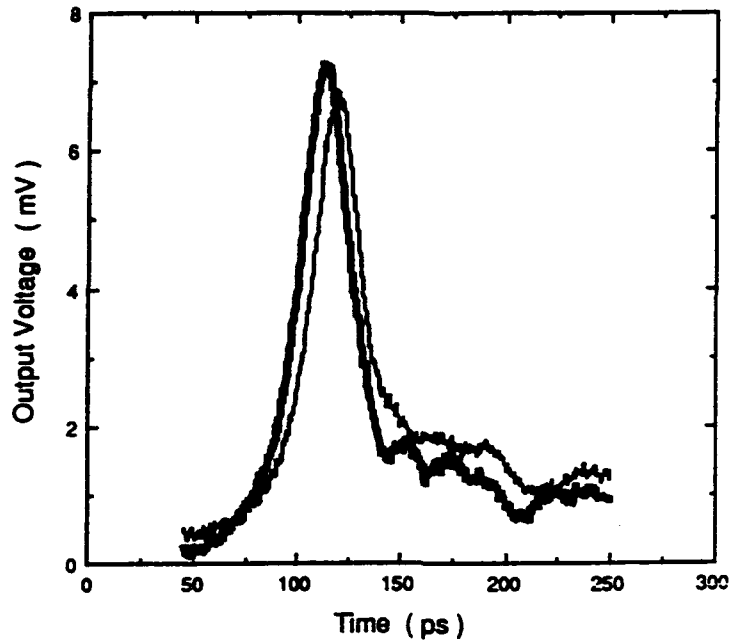
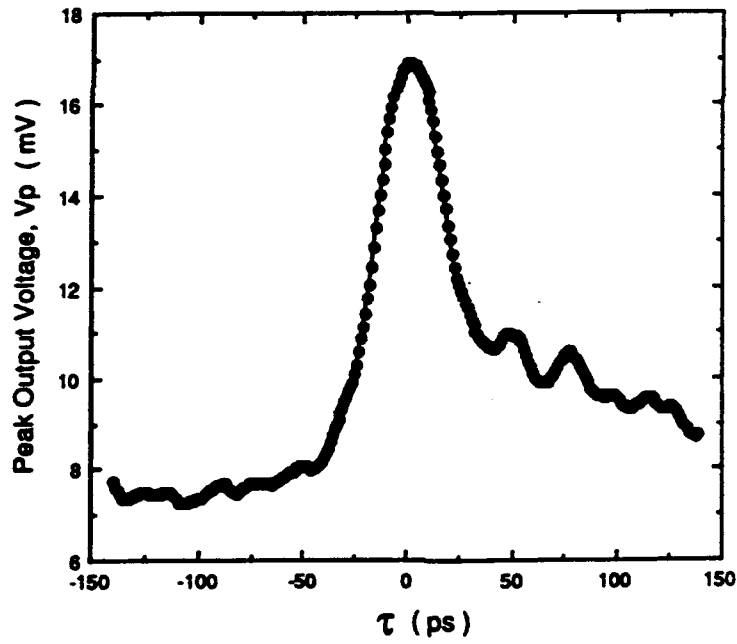

Figure 3.1 Experimental setup for AND Gate measurements.



(a)



(b)

Figure 3.2 Photoconductive gate (a) impulse responses and (b) correlation reponse.

approximately 2:1. The impulse response and time-resolved correlation measurements verified that the AND gate could operate at 5 Gbps with low cross-talk from pulses in adjacent time-slots. Furthermore, the low-noise characteristics of the photoconductive gate offset the gate's low contrast ratio to yield a 57 dB SNR and a BER performance of less than 10^{-15} .

3.3 Future AND Gate Experiments

Work is now underway to develop an AND gate fast enough to demultiplex baseband information from a data stream with aggregate data-rates above 5 Gbps. The new AND gate will consist of two photon assisted Al/AlO₃ tunneling diodes connected in series. Several devices will be fabricated as part of this effort. Measured data based on several parameters, such as impedance as a function of frequency, will provide information to calculate the exact thickness of the insulating layer of the tunnel junction. Additional devices will be fabricated and tested in an optical TDM interconnect environment.

4. OPTICAL DELAY LINE CODER

4.1 OTDM Coder Description

In many optical communication systems applications, such as broad-band networks, packet-switching, and computer interconnects, optical time-division multiaccess (OTDM) has become an important

means of simultaneously carrying many data channels on a single fiber [16-18]. OTDM works as follows. If N data channels, each with a bit rate $1/T$, are to share the fiber, then each bit interval is divided into N time slots $j = 0, \dots, N-1$ of duration t within a time frame of duration T as illustrated in Fig. 4.1. The time slots correspond to addresses, either of the source (as in fixed-transmitter assignment OTDM) or the destination (as in fixed-receiver assignment OTDM).

The OTDM coder selects the desired address by delaying the data to the appropriate time slot. OTDM differs from conventional electrical TDM in that optical rather than electrical delays are used in the coder [19-21], which allows the manipulation of extremely short optical pulses generated by a mode-locked laser and correspondingly short time slots t (as short as a few femtoseconds duration). Since the maximum throughput N/T of the network is $1/t$, OTDM can yield much higher throughputs (as high as several Tb/s) than electrical TDM. For high-speed access to a large network, the OTDM coder must rapidly select one of a large number of optical delays.

4.2 OTDM Coder Operational Configuration

The coder shown in Fig. 4.1 allows rapid tuning among a large number of delays. The feed-forward structure consists of $\log_2 N$ delay stages $k = 1, \dots, \log_2 N$ and an output stage. Thompson has

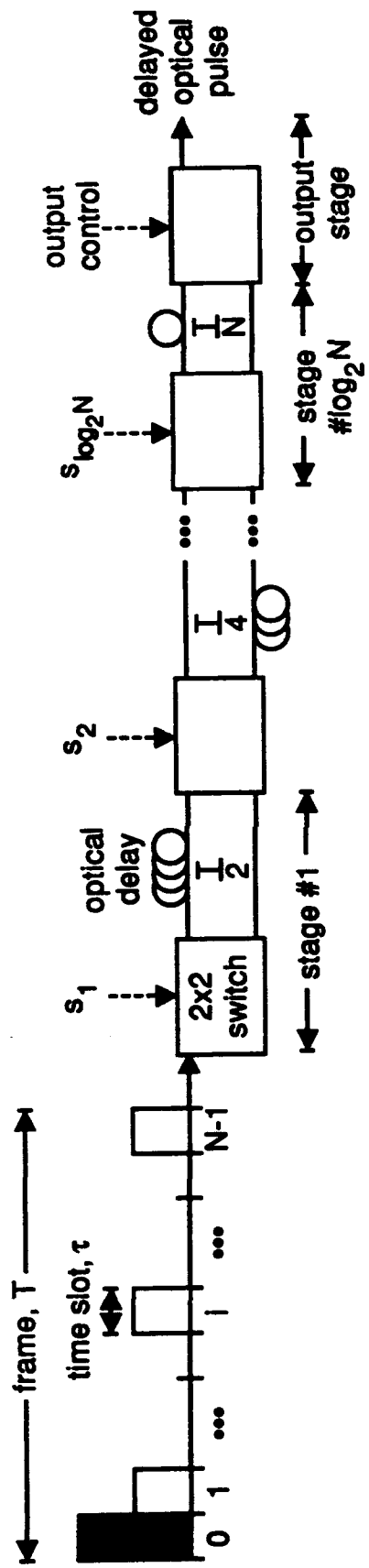

Figure 4.1 Schematic diagram of the OTDM Coder.

shown analytically that a feed-forward structure requires fewer stages than a feed-back structure [22]. Each delay stage consists of a 2x2 optical switch, a connection to the next stage at one output, and a fixed optical delay in excess of the "connection" delay at the other output. The value of the fixed excess delay for the k th stage is $T/2^k$. Only one input is used to the first stage. The output stage consists of a 2x2 optical switch, where only one output is used. Each optical switch can rapidly be set in either the bar or cross state. The state of a switch is set by the electrical control input, where a 0 at the control sets the 2x2 switch in the cross state, whereas a 1 sets the 2x2 switch in the bar state.

The state of the coder is set by a control sequence $(S_1, S_2, \dots, S_{\log_2 N})$, where control bit S_k sets the state of the k th stage, and the output stage is set equal to 0 if the parity of the control sequence is odd, or to 1 if the parity of the control sequence is even. The output stage serves only to ensure that the delayed pulse always exits at the chosen output of the 2x2 optical switch. The control sequence for the j th slot is generated from the binary representation of the integer j , $(b_1, b_2, \dots, b_{\log_2 N})$ where b_1 is the most significant bit, according to the rule $S_1 = (\text{not})b_1$, and for $i=2, \dots, \log_2 N$, $S_i = 0$ if $b_i = b_{i-1}$, otherwise $S_i = 1$.

After the control sequence has set the coder as described above, the sampled data will be delayed by an amount jt in excess of the reference delays, accomplishing the desired time-division coding operation.

An OTDM coder is presented for 64 100 Mb/s channels. Here $T = 10$ ns and $t = 156.25$ ps. The complete coder requires six delay stages $k=1, \dots, 6$ with time delays $D_k = 10/2^k$ ns, corresponding to fiber lengths $L_k = 2.052/2^k$ m, where the index of refraction of the fiber core is $n_f = 1.462$.

4.3 OTDM Coder Performance

Various coder delays were measured using a Nd:YAG laser operating at 1.3 microns and generating 100 ps optical pulses at a 100 MHz repetition rate. As shown in Fig. 4.2, the output of the laser is split by a coupler (c) so that part of the optical pulse propagates through the coder and the remainder through a reference delay. The output of the coder and the reference delay are combined by a coupler (C2), detected by a 20 GHz bandwidth photodetector (PD) and displayed on a sampling oscilloscope. In OTDM network applications, recovery of data within a given time slot can be performed by optical coincidence detection with a synchronous optical pulse train using, for example, the photoconductive AND gate described previously [8,23].

Shown in Fig. 4.3 are the reference pulses (higher peaks) and coded pulses (lower peaks), corresponding to the following time slots: (a) slot 0 (ideal delay 0 ps); (b) slot 1 (ideal delay 156.25 ps); (c) slot 16 (ideal delay 2.5 ns); (d) slot 32 (ideal delay 5 ns); and (e) slot 49 (ideal delay 7.65625 ns). Slots 17, 33, and 48 were also coded but the results are not shown here. The

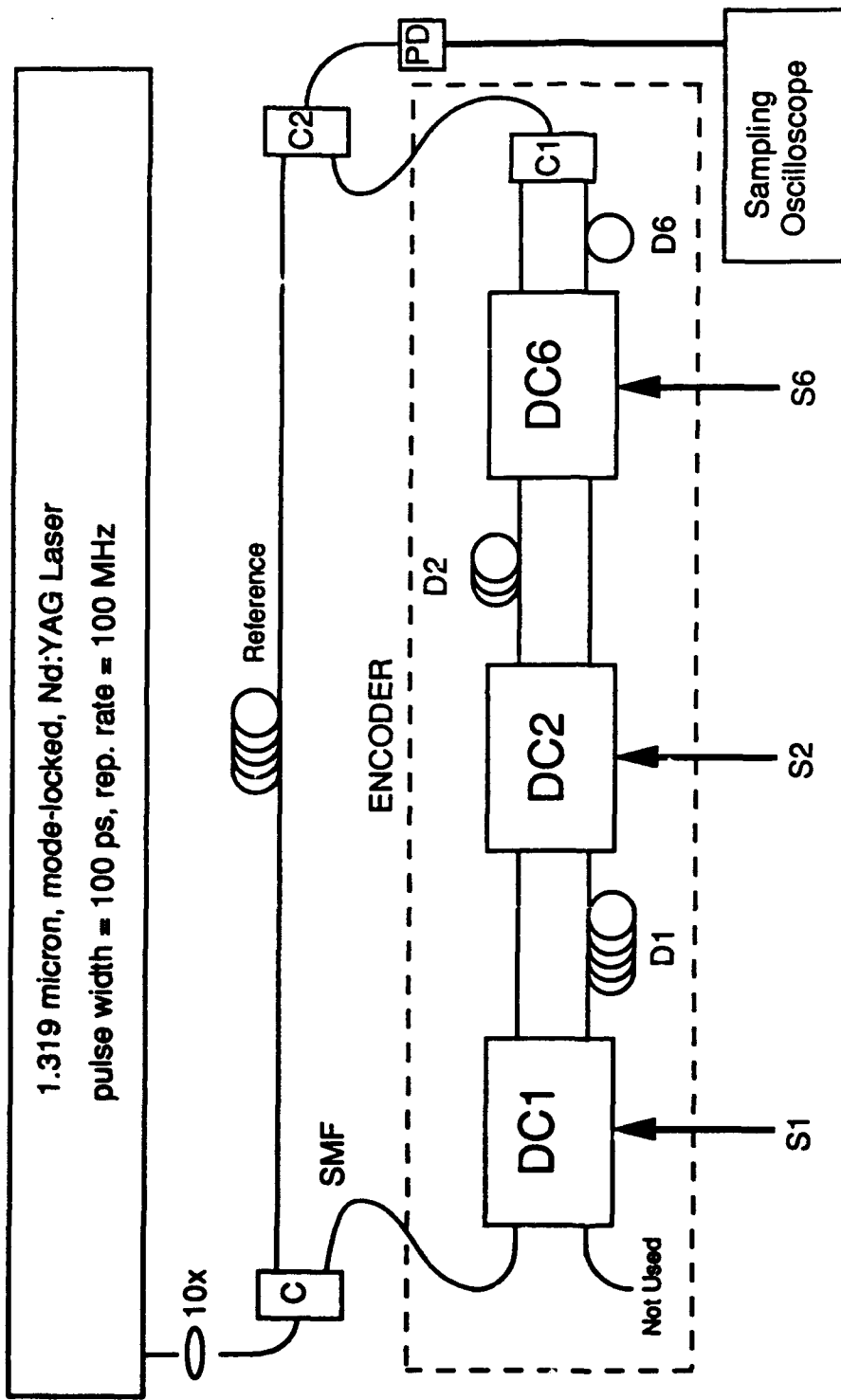

Figure 4.2 Experimental setup for an eight channel coder demonstration.

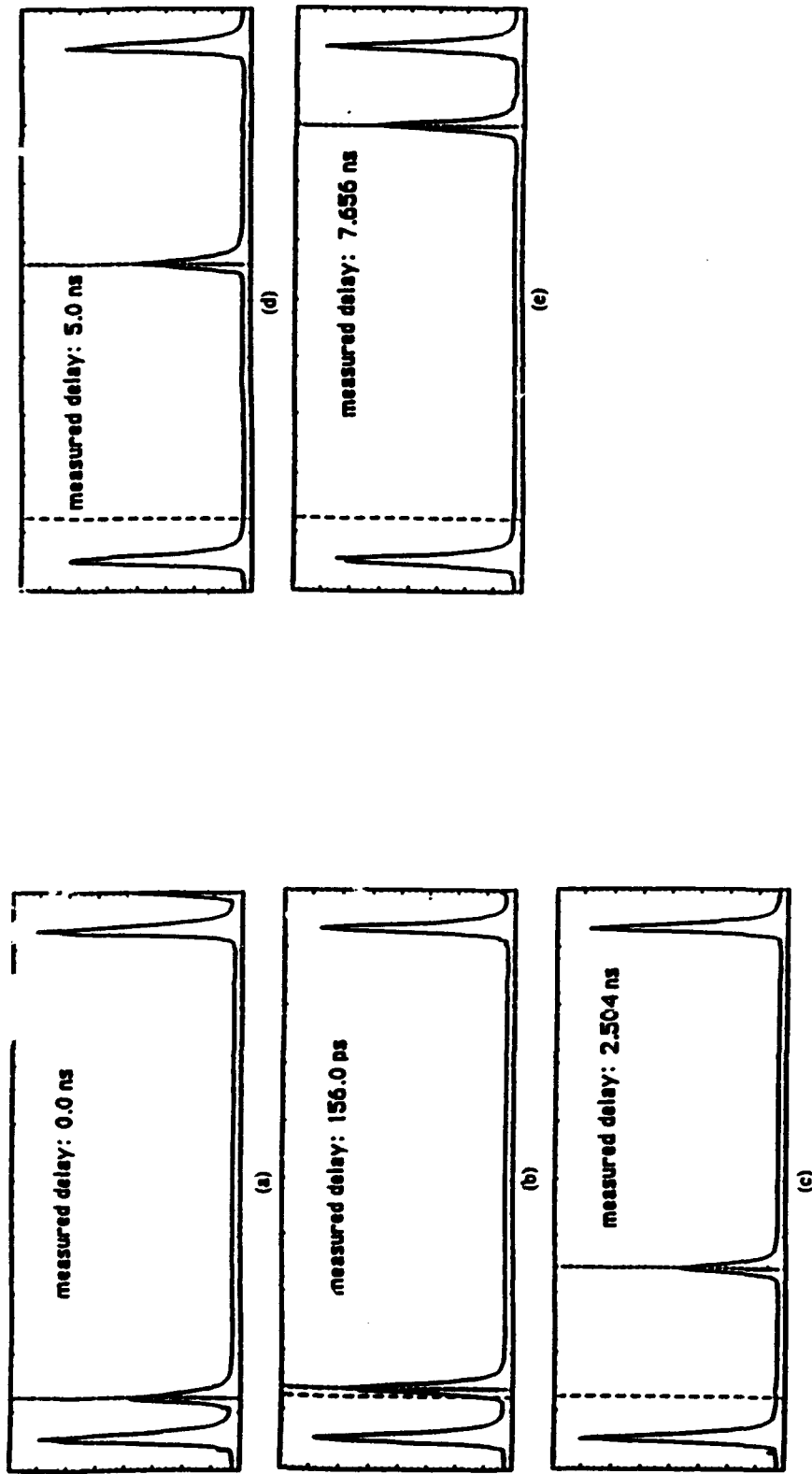

Figure 4.3 Experimental results of code: experiment.

time delay relative to slot 0, measured with the oscilloscope's cursor function, is shown for each case. The maximum aggregate error in measured delay is 2.5% of a time slot. This could be due to measurement error (positioning of the cursor on the oscilloscope) or an error in the length of fiber in stage 2.

The measured input and output powers of the coder are 399 and 1 uW, corresponding to approximately 26 dB total insertion loss. This includes 3 dB splitting loss in C1, and insertion losses of 3.5 dB in DC1, 4.5 dB in DC2, and 15 dB in DC6. These insertion losses are primarily due to fiber-to-waveguide coupling at the input and output of the directional couplers, which can be compensated using fiber amplifiers.

The design of the OTDM coder is influenced by the number of channels N and the bit-rate per channel $1/T$: t determines the minimum delay as well as the precision required. For delays $T/2$ longer than approximately 50 ps ($1/T < 10$ Gb/s), either fiber or integrated-optic delays may be suitable due to the long path length required (> 1 cm). Long delays (several tens of cm) have been demonstrated using low-loss (0.04 dB/cm) doped silica integrated-optic waveguides [24]. For delays shorter than 50 ps, integrated-optic waveguides are most suitable, since lithographic techniques can routinely yield a precision of less than 1 μm (5 fs delay).

In situations where N is large, both long and short delays are required with an error of less than $T/10 N$. For example, if $1/T = 1$ Gb/s and $N = 1000$ (10 stages) then the total error in delay should be less than 20 μm . This is easily achieved with

integrated-optic waveguides, which would be used for the last seven stages of the coder, ranging in length from 1.25 cm (T/16) to 195 μ m (T/1028). However, this precision could not easily be achieved if fiber-optic delays are used for the first three stages of the coder, ranging in length from 10 cm (T/2) to 2.5 cm (T/8). Here, long serpentine integrated-optic delays would yield the required precision [24].

5. SUMMARY

This work demonstrates the potential of optics to process information at rates much higher than electronics. However, the impact of optical processing capabilities has yet to be experienced by the military user. Specific device developments are required before this potential can be realized. Many of the key devices required which were barely definable a few years back are now being developed within the Photonics Center at Rome Laboratory. Some of the devices being developed that hold the key to superior military systems are optical amplifiers, MQW detectors and optical delay line coders (an integrated device).

Due to a rapid change in world politics, it will become necessary to develop systems capable of handling a great deal of intelligence and surveillance information as we move away from a large global military structure and into a reduced force required to monitor worldwide situations and move rapidly and decisively when required.

Processing speeds continue to escalate and reaction times in military situations continue to decrease. Both these factors put severe demands on interconnect systems. Military applications in the 21st Century dictate that arbitration be capable of multi-gigabit rates. The answers to these demands will be found in optical network technology such as that contained in this report and in the references cited.

6. REFERENCES

- [1] P.R. Prucnal and P.A. Perrier, "A New Direction In Photonic Switching," Proc. 9th International Conf. on Comp. Communication, pp. 149-154, 1988.
- [2] P.R. Prucnal, "A Collapsed-Network Space Division Switching Architecture," Photonics Switching, J.E. Midwinter and H.S. Hinton, eds., (Optical Society of America, Wash.D.C.1989), pp. 200-207.
- [3] P.R. Prucnal and P.A. Perrier, "Passive Shared Media Systems," Proc. IEEE International Conference on Communications, pp.1135-1139, 1990.
- [4] P.A. Perrier and P.R. Prucnal, "High Dimensionality Shared-Medium Photonic Switch," IEEE Trans. on Communications, in press.
- [5] K.Y. Eng, M.A. Santoro, T.L. Koch, J. Stone, and W.W. Snell, "Star-Coupled Optical Cross-Connect Switch Experiments With Tunable Receivers," "IEEE Journal On Selected Areas In Communications," Vol. 8, No. 6, pp. 1226-1031, August 1990.
- [6] I.P. Kaminow, P.P. Iannone, J. Stone, and L.W. Stulz, "FDMA FSK Star Network With A Tunable Optical Filter Demultiplexer," IEEE Journal of Lightwave Technology, Vol. 6, No. 9, pp. 1406-1414, 1988.

[7] P.R. Prucnal, M.A. Santoro, S.K. Sehgal, and I.P. Kaminow, "TDMA Fiber Optic Network With Optical Processing" *Electronic Letters*, Vol. 22, No.23, pp. 1218-1219, 1988.

[8] P.R. Prucnal, M.A. Santoro, and S.K. Sehgal, "Ultra-fast All-Optical Synchronous Multiple Access Fiber Networks," *IEEE J. Selected Areas of Communications*, SAC-4, No. 9, pp. 1484-1493, 1986.

[9] P.R. Prucnal, D.J. Blumenthal, and M.A. Santoro, "A 12.5 Gbps Fiber-Optic Network Using All-Optical Processing," *Electronic Letters*, Vol. 23, No. 12, pp. 629-630, 1987.

[10] "Ultra-fast All-Optical Synchronous Multiple-Access Fiber Networks," Photonics Switching, J.E. Midwinter and H.S. Hinton, eds (IEEE Press, Progress in Lasers and Electro-Optics Series, NY, 1990, Reprinted From *IEEE J. Selected Areas of Communication*, SAC-4, No. 9, pp. 1484-1493, 1986).

[11] F.B. McCormick, A.L. Lentine, R.L. Morrison, S.L. Walker, L.M.F. Chirovsky, and L.A. D'Asaro, "Simultaneous Parallel Operation of an Array of Symmetric Self-Electrooptic Effect Devices," *Technical Digest*, OSA annual meeting, Paper MII4, 1989.

[12] F.B. McCormick, and M.E. Prise, "Optical Circuitry For Free-Space Interconnects," *Applied Optics*, Vol. 29 No. 14, pp. 2013-

2018, May 1990.

[13] P.R. Prucnal, M.F. Krol, and J.L. Stacy, "Demonstration of a Rapidly-Tunable Optical Time-Division Multiple access Coder," IEEE Photonics Technology Letters, Vol. 3, No. 2, pp. 170-172, Feb. 1991.

[14] E. Desurvire, B. Tell, I.P. Kaminow, G.J. Qua, K.F. Brown-Goebeler, B.I. Miller, and U. Koren, "High Contrast InGaAs:Fe Photoconductive "AND" Gate for Time-Division Demultiplexing," Electronics Letters, Vol. 24, No. 7, pp. 396-397, 1988.

[15] D.H. Auston, A.M. Johnson, P.R. Smith, and J.C. Bean, "Picosecond Optoelectronic Detection, Sampling, and Correlation Measurements in Amorphous Semiconductors," Applied Physics Letters, Vol. 37, No. 4, pp. 371, 1980.

[16] T.S. Kinsel and R.T. Denton, "Terminals for High-Speed Optical Pulse Code Modulation Communication System:II. Optical Multiplexing and Demultiplexing," Proc. IEEE, Vol. 56, pp. 146-154, 1968.

[17] I.P. Kaminow, "Proposed Electrooptical PCM Multiplexer-Demultiplexer," IEEE Journal of Quantum Electronics, Vol. QE-7, No. 11, pp. 533-535, 1971.

[18] P.R. Prucnal, M.A. Santoro, and S.K. Sehgal, "Ultra-fast ALL-

Optical Synchronous Multiple Access Fiber Networks," IEEE Journal on Selected Areas in Communications, Vol. SAC-4, No. 9, pp. 1484-1493, 1986.

[19] K.P. Jackson, et al., "Optical Fiber Delay-Line Signal Processing," IEEE Trans. on Microwave Theory and Techniques, Vol. MTT-33, No. 3, pp. 193-209, 1985.

[20] R.A. Soref, "Programmable Time-Delay Devices," Applied Optics, Vol. 23, No. 21, pp. 3736-3737, 1984.

[21] R.I. MacDonald, "Switched Optical Delay-Line Signal Processors," Journal of Lightwave Technology, Vol. LT-5, No. 6, pp. 856-861, 1987.

[22] R.A. Thompson, "Optimizing Photonic Variable-Integer-Delay Circuits," Topical Meeting on Photonic Switching(Incline Village, NV, 18-20 March 1987), Technical Digest, Vol. 13, paper FD4, pp. 241-243.

[23] K.K. Goel, et al., "Demonstration Of Packet Switching Through an Integrated Optic Tree Switch Using Photoconductive Logic Gates," Electronic Letters, Vol. 26, No. 5, pp. 287-288, 1989.

[24] Y. Ohmori, et al., "Low Loss GeO₂-Doped Silica Waveguides For Large Scale Integrated Optical Devices," Proc. OFC'90, Paper WE2, p. 61.