

AD-A253 901



92-22637



REPORT DOCUMENTATION PAGE

Form Approved OMB No. 0704-0188

Public reporting burden for this collection of information is estimated to average 1 hour per response, including the time for reviewing instructions, searching existing data sources, gathering and maintaining the data needed, and completing and reviewing the collection of information. Send comments regarding this burden estimate or any other aspect of this collection of information, including suggestions for reducing this burden, to Washington Headquarters Services, Directorate for Information Operation and Reports, 1215 Jefferson Davis Highway, Suite 1204, Arlington, VA 22202-4302, and to the Office of Management and Budget, Paperwork Reduction Project (0704-0188), Washington, DC 20503.

| | | | | | |
|--|--|---|--|---|--|
| 1. AGENCY USE ONLY (Leave blank) | | 2. REPORT DATE July 1992 | | 3. REPORT TYPE AND DATES COVERED Final/Nov 89 to Feb 92 | |
| 4. TITLE AND SUBTITLE PACKAGE ENHANCEMENT STUDY FOR THE 120-mm M831E2 CARTRIDGE | | | | 5. FUNDING NUMBERS | |
| 6. AUTHOR(S) Leon Manole, Ray Dunscomb, and Stewart Gilman | | | | | |
| 7. PERFORMING ORGANIZATION NAME(S) AND ADDRESSES(S) ARDEC, CCAC Heavy Armament Division (SMCAR-CCH-V) Picatinny Arsenal, NJ 07806-5000 | | | | 8. PERFORMING ORGANIZATION REPORT NUMBER Technical Report ARDEC-TR-92006 | |
| 9. SPONSORING/MONITORING AGENCY NAME(S) AND ADDRESS(S) ARDEC, IMD STINFO Br (SMCAR-IMI-I) Picatinny Arsenal, NJ 07806-5000 | | | | 10. SPONSORING/MONITORING AGENCY REPORT NUMBER | |
| 11. SUPPLEMENTARY NOTES | | | | | |
| 12a. DISTRIBUTION/AVAILABILITY STATEMENT Approved for public release; distribution is unlimited. | | | | 12b. DISTRIBUTION CODE | |
| 13. ABSTRACT (Maximum 200 words) An engineering study to reduce the cost of the existing 120-mm, target practice-tracer (TP-T), M831 tank cartridge, is being conducted by ARDEC, Picatinny Arsenal, NJ. The redesigned cartridge, designated M831E2, is packaged in the standard PA116 metal can used for the M831 and is subject to standard test and evaluation command (TECOM) rough handling tests. Testing at Aberdeen Proving Ground, 16 to 18 Jan 92, showed the 7-ft packaged drop (containing the cartridge) at -46°C to be the most severe of the rough handling package tests. Both the M831 and M831E2 combustible cartridge case sustained damage. A package enhancement design and test were run to study the possible improvements that could be made to the internal packaging components of the PA116 container to improve the survivability of the combustible cartridge case in the 7-ft packaged drop test. A 6 lb/cubic foot crosslinked polyethylene foam support added to the PA116 container at the projectile/combustible case cap interface gave substantial improvement to the survivability of the cartridge case in the 7-ft -46°C packaged drop test. | | | | | |
| 14. SUBJECT TERMS M831 cartridge M831E2 packaged drop PA116 container enhancement PA116 package enhancement | | | | 15. NUMBER OF PAGES 33 | |
| | | | | 16. PRICE CODE | |
| 17. SECURITY CLASSIFICATION OF REPORT UNCLASSIFIED | | 18. SECURITY CLASSIFICATION OF THIS PAGE UNCLASSIFIED | | 19. SECURITY CLASSIFICATION OF ABSTRACT UNCLASSIFIED | |
| | | | | 20. LIMITATION OF ABSTRACT SAR | |

CONTENTS

| | Page |
|--|------|
| Introduction and Background | 1 |
| Description of the M831 and M831E2 Cartridge | 3 |
| Description of the PA116 Container | 5 |
| Description of the 7-ft Packaged Drop Test | 6 |
| Description of Package Enhancement Supports | 7 |
| Discussion | 7 |
| Results | 9 |
| Conclusions and Recommendations | 10 |
| Distribution List | 29 |

TABLES

| | | |
|---|--|----|
| 1 | Properties of unfabricated Ethafoam brand products | 11 |
| 2 | M831E2 metal can 7-ft drop test results | 12 |
| 3 | Drop sequence for M831E2 package enhancement test | 13 |
| 4 | Seven foot, -46°C, M831E2, package enhancement drop test results, 21 February 1992 | 14 |

DTIC QUALITY INSPECTED 6

| | |
|---------------------------|-------------------------------------|
| Accession For | |
| NTIS CRA&I | <input checked="" type="checkbox"/> |
| DTIC TAB | <input type="checkbox"/> |
| Unannounced | <input type="checkbox"/> |
| Justification | |
| By | |
| Distribution / | |
| Availability Codes | |
| Dist | Avail and / or Special |
| A-1 | |

FIGURES

| | | Page |
|----|--|------|
| 1 | Cartridge, 120-mm, HEAT-MP-T, M830 and cartridge, 120-mm TP-T, M831 | 15 |
| 2 | Cartridge, 120-mm, TP-T, M831E2 | 16 |
| 3 | PA116 container drawing | 17 |
| 4 | PA116 container and internal supports | 18 |
| 5 | Aberdeen Proving Ground 7-ft drop site | 19 |
| 6 | Aberdeen Proving Ground 7-ft drop set-up with containers in nose down orientation before being lifted to 7 ft | 20 |
| 7 | Case cap support drawing | 21 |
| 8 | Case cap support | 22 |
| 9 | Spike donut drawing | 22 |
| 10 | Spike donut | 22 |
| 11 | M831E2 cartridge after 7-ft packaged drop test at -46°C, cartridge case cracked at case cap/projectile interface | 23 |
| 12 | M831E2 cartridge after 7-ft packaged drop test at -46°C, two cracks along cartridge case | 24 |
| 13 | M831 cartridge after 7-ft packaged drop test at -46°C, crack in case cap and cracks in cartridge case caused by internal fin | 25 |
| 14 | M831 cartridge after 7-ft packaged drop test at -46°C, crack in case cap and bulge/crack in cartridge case cap | 26 |
| 15 | M831 cartridge after 7-ft packaged drop test at -46°C, bulge in cartridge case | 27 |

INTRODUCTION AND BACKGROUND

The U.S. Army Armament Research, Development and Engineering Center (ARDEC), Heavy Armament Division of Close Combat Armament Center (CCAC), is working on an engineering study (1A-9-8628) to reduce the cost of the existing 120-mm, target practice-tracer (TP-T), M831 tank cartridge. The redesigned new cartridge is designated the M831E2.

The M831E2 engineering study was approved by the AMCCOM Configuration Control Board (CCB) in November 1989 and funded in March 1990. The engineering study was divided into three phases.

Phase I was the concept, design, and test phase. During this phase, the target impact dispersion (TID), modified ballistic match, and strength of design (SOD) for the M831E2 were proven out by testing at Aberdeen Proving Ground (APG), Maryland. Phase I was completed in September 1990, with the M831E2 successfully passing the TID, SOD, and modified ballistic match tests.

Phase II was intended to study the M831E2 cartridge integrity in the standard rough handling tests for tank ammunition. In addition, an improved tracer design was tested and a different propellant lot fired for ballistic information. The tracer test and the different propellant lot test were completed on 6 March 1992 at APG. The testing was extremely successful showing that the new tracer design was acceptable for the M831E2 and that another propellant lot yielded good ballistics for the M831E2.

It was anticipated that the M831E2 would have some difficulties in the rough handling tests since the existing M831, which contains the same combustible cartridge case and cap as the M831E2, experiences problems. The combustible cartridge case and cap are made from a nitrated cellulose wood pulp and are 3.1 to 3.5 mm thick. The combustible cartridge case and cap have the appearance, feel, and structural integrity of a paper product. The combustible case and cap are subject to cracking when exposed to impact shock such as being dropped.

The rough handling test for phase two began in November 1991 at APG. The 7-ft packaged drop test with the PA116 metal container packed with M831 as well as M831E2 cartridges, conducted 16 to 18 January 1992, was the most severe of the rough handling tests performed, as indicated by damage to both the M831 and M831E2 cartridges. The tests were done at hot (63°C) and cold (-46°C) temperatures. Each cartridge was dropped twice. The cold testing proved to be much more severe than the hot testing. Five of the eight M831E2 cartridges dropped in the cold 7-ft package drop test were damaged. Two M831 cartridges were dropped in the same

test for comparison and both were damaged. For the hot 7-ft package drop test, four out of the six M831E2 cartridges dropped were damaged and two out of two M831 cartridges dropped were damaged. However, the amount of damage sustained by the cartridges was visibly much less severe for the hot test condition.

The other rough handling tests conducted for the M831E2 at APG, from November 1991 to February 1992, were the 7-ft pallet drop and loose cargo vibration, which were done with the cartridge in the PA116 container. There was no visible damage to the M831E2 when it was packaged correctly. An earlier incident during the loose cargo vibration testing, where the M831E2 cartridges were not packaged correctly, had several of the cartridges damaged. An inspection by an ARDEC packaging engineer has shown that the proper amount of fiber board filler to ensure a tight pack was missing. Repeating the test with the cartridges properly packaged showed no damage to the cartridge. Most of the M831E2 cartridges subjected to the rough handling tests were fired at APG, with successful ballistics achieved.

It should be noted that the M831E2 cartridges used in the 7-ft packaged drop test had been subjected to one or more of the other rough handling tests before being dropped. The M831 cartridges were only subjected to the 7-ft packaged drop test and not to the other rough handling tests because of cost considerations.

A transportation storage sequence was also performed on the M831E2. These tests included a hot and cold secure cargo vibration, hot/dry storage test, hot/humid storage test, and rack vibration. The hot and cold secure cargo vibration were done with the M831E2 cartridge packed in the PA116 container while the other tests were performed on the bare cartridge only. This transportation storage sequence was also performed at APG during November 1991 and February 1992. There was no visible damage to the M831E2 cartridges and all cartridges fired demonstrated successful ballistics.

After reviewing the data from APG, it was seen that the only problem area for the rough handling and transportation storage sequence was the 7-ft package drop test. A meeting was held to analyze the PA116 container and internal support interface with the M831 and M831E2 cartridge. It was shown that the projectile/case cap interface areas of the M831 and M831E2 cartridges needed additional support in the PA116 container.

A package enhancement design and test study was conducted to evaluate the possible improvements that could be made to the PA116 container internal supports and cushions to improve the survivability of the combustible cartridge case in the 7-ft packaged drop test. Supports and "donuts" made of polyethylene foam were designed and manufactured to provide additional support to the cartridge while in the

PA116 container to different areas of the projectile. A drop test sequence was designed to compare the different supports and donuts to determine if they offered the cartridge additional protection in the drop test. The drop test containing the package enhancement supports and donuts was conducted at APG on 21 February 1992.

Phase III is the technical test/user test and is not discussed in this report.

DESCRIPTION OF THE M831 AND M831E2 CARTRIDGE

The M831 TP-T (fig. 1) is the training round for the M830 MP-T (fig. 1) high explosive antitank (HEAT) round. The M831, TP-T, contains no explosive or fuze and ballistically matches the flight characteristics of the M830.

Referring to figure 1, the projectile components of the M831 TP-T are as follows:

- Solid aluminum spike
- Hollow steel body
- Aluminum boom
- Aluminum fin
- Aluminum ring
- Copper obturator

The energetic components are as follows:

- DIGL-RP double base propellant (several forms in different bags)
- Combustible case cap
- Combustible cartridge case
- Tracer
- M123A1 Primer

The remaining metal parts for the cartridge include:

- **Case base and seal assembly**
- **Spring disc**
- **Retaining ring**
- **Lead coil**

The M831E2 TP-T (fig. 2) is a modification of the M831 round. The M831E2 is a ballistic match to the M831 and M830. The design has been developed for the purpose of cost saving. Several major changes were made to the M831 to design the M831E2 which created the savings. These changes include:

- **Modification of the metal parts**
- **Modification to the propulsion system**

The metal parts changes include replacement of:

- **The solid aluminum spike with a solid steel spike**
- **The hollow steel body with a hollow aluminum body**
- **The copper obturator with a nylon obturator**
- **The boom and fin with an aluminum stabilizer**

The propulsion system changes are:

- **Replacement of the DIGL-RP propellant, with M14 single base propellant held in a cloth bag**
- **The forward combustible disc which supports the boom in the M831 cartridge was used and glued to the stabilizer to prevent the stabilizer from cutting the propellant bag**
- **The M123A1 primer was changed to the M125 primer**
- **Elimination of the lead coil**
- **Press-in tracer to a drop-in tracer (same composition in an aluminum cup)**

All other components of the M831E2 are the same as the M831. The major cost savings from these changes comes as a result of the removal of the fin and boom and the change-over to the much less expensive M14 propellant.

The same combustible cartridge case and cap are used for the M831 and M831E2. They are made from a nitrated craft wood pulp cellulose. DOD-C-63486, combustible case, cartridge, 120-mm M830/M831, parts for, is the specification which governs the properties of these parts. The case is subject to a crush deformation test and the cap is subject to a tensile test as per the specification. The mechanical properties of the case and cap give it enough strength to load and handle the cartridge without damage, however, little protection against breakage when dropped.

DESCRIPTION OF THE PA116 CONTAINER

The PA116 container (figs. 3 and 4) is a cylindrical, square-rimmed, metal ammunition container. It is currently used to package all 120-mm tank ammunition. The container's outside dimensions are 44.5 by 7.75 in. and it is constructed of high strength, low alloy steel.

Within the metal container is a system of internal cushioning and supports (figs. 3 and 4) unique for each round of ammunition. The major internal components consists of: a rigid high density polyethylene projectile support, an 8-lb/ft³ density crosslinked polyethylene foam sleeve which support the combustible cartridge case, and two 6-lb/ft³ density noncrosslinked polyethylene foam cushions which provide cushioning at both ends of the container.

The foam sleeve is attached to the molded projectile support by means of a nylon strap and the whole cushion assembly is held in place by a U-shaped steel yoke assembly. The yoke assembly allows the projectile support and foam sleeve to slide a few inches while still providing a positive stop. This eases removal of the cartridge and protects the combustible cartridge case from being damaged by scraping the container rim.

The cartridge is slid into the container, projectile first, until the leading edge of the bourrelet rests against the molded projectile support. Filler material is added behind the cartridge to ensure a tight pack before the lid (with attached base cushion) is put in place. Filler material consists of several thin discs of chipboard and one thin disc of 4-lb/ft³ density noncrosslinked polyethylene foam. An insufficient quantity of filler material (i.e., loose pack) will normally result in a cartridge sustaining excessive damage (cracking and bulging) to the combustible cartridge case, especially in the vicinity of the case base area, when subjected to rough handling.

One potential shortcoming of the standard PA116 pack is that it provides no support to the projectile/combustible case adapter interface. There exists approximately 4 in. of unsupported span (fig. 3) between the foam sleeve and cartridge extending from the point where the combustible case cap begins necking down forward to the molded projectile support. Even though the projectile is laterally supported along approximately 90% of its length, there is nothing restricting any side to side or wobbling motion of the projectile/cartridge case interface. For this reason, cold temperature 7-ft drops in horizontal orientations frequently produce damaged case caps. Greater support in this area could greatly reduce the tendency for this type of damage.

DESCRIPTION OF THE 7-FT PACKAGED DROP TEST

The most severe of TECOM's packaged safety test is the 7-ft (2.1 m) individual packaged drop. For 120-mm tank ammunition, in general, and M831 and M831E2 cartridges in particular, testing is done at cold (-46°C) and hot (63°C) temperatures. Each cartridge, packaged in a PA116 container, is dropped 7 ft onto a steel surface (fig. 5)

The cold test takes place with the containers (containing the cartridges) temperature conditioned to -46°C, for a minimum of 24 hr. The packaged cartridges are temperature conditioned in a portable cold box located near the drop site.

Two packaged cartridges are removed from the temperature box for drop testing and brought to the drop site by truck. The containers are tied (fig. 6) to a metal bar in the orientation that they will be dropped. The metal bar is attached to a steel cable which lifts the bar and cartridges to the desired height. A camera is set up so that an operator in a remotely located building can control the lifting of the cartridges to 7 ft by viewing a television screen. A premade reference line tells the operator where 7 ft is. When the bottom of both containers is at 7 ft the operator pushes a switch which releases the containers from the bar allowing them to free fall and subsequently impact the steel impact surface.

Each container is dropped twice; in two of five possible orientations. The five orientations are as follows: horizontal, cartridge base down, cartridge base up, 45 degrees cartridge base down, and 45 degree cartridge base up.

The hot (63°C) temperature drop test is done exactly the same way as the cold except the packaged cartridges are conditioned to the hot temperature for a minimum of 24 hr.

The cold temperature portion of the drop tests has historically proven more damaging than the hot (+63°C) portion because of the increased brittleness of the combustible cartridge case at -46°C. Typical combustible cartridge case damage seen with all the 120-mm tank ammunition as a result of these drop tests are: (1) cracks or bulging just forward of the cartridge case base, (2) longitudinal cracks in the cartridge case wall due to internal fin impact, and (3) cracking in the case adapter area because of a bending moment in the vicinity of the case adapter/projectile interface. Additional support at the projectile/case adapter interface should greatly reduce this torsional motion thereby minimizing the second and third types of damage mentioned above. As the M831E2 possesses the finless projectile, the second type of damage mentioned above is only a concern with the standard finned, M831 cartridge.

DESCRIPTION OF PACKAGE ENHANCEMENT SUPPORTS

The case cap support (figs. 7 and 8) was designed to enhance the performance of the PA116 container, particularly for the M830, M831, and M831E2 cartridges. It is an insert designed to be incorporated directly into the container and cushion assembly, which is currently identical for these three cartridges. It provides increased lateral support to the projectile by filling the ullage that existed at the case cap/projectile interface. Case cap supports were fabricated from two types of noncrosslinked polyethylene foam; Ethafoam HS-600 and HS-45 brand plank polyethylene foam were used. Ethafoam is a trademark of the Dow Chemical Company. HS-600 and HS-45 display, respectively, average densities of 6.6 and 3.8 lb/ft³. Material properties of these and other Ethafoam products are given in table 1. HS-600 is a much more robust product than HS-45, as is illustrated by their differing compressive strengths (table 1).

The spike donut (figs. 9 and 10) was also designed to increase lateral support to the projectile. Unlike the case cap support, which provides additional support at the projectile base, the spike donut supports the projectile at its forward section. It was designed to fit on the end of the projectile spike, filling the ullage between the spike and the inside surface of the molded projectile support. Spike donuts were also fabricated from Ethafoam HS-600 and HS-45 plank polyethylene foam.

DISCUSSION

The 7-ft packaged drop test for the M831E2 was conducted at APG, 16 to 18 January 1992. Six M831E2 and two M831 packaged cartridges, temperature conditioned to 63°C, were dropped 16 to 17 January 1992. Eight M831E2 and two M831 packaged cartridges, temperature conditioned to -46°C, were dropped 18 January 1992. Each cartridge was dropped twice and examined after each drop.

The M831E2 metal container 7-ft drop test summary (table 2) shows which rounds were dropped, the orientation of the drops, and the damage to the cartridge after the two drops. The hot test results are separated from the cold test results. There are five categories of damage given to the cartridges in table 2. The first three categories: (1) separation, (2) 360 deg crack at projectile/cap interface, and (3) interface crack and longitudinal crack, are the most severe damage categories. Category 1, separation, is the most severe with severity decreasing as the category number increases, with category 4, slight crack at projectile/case cap interface, being the least severe damage noted in drop test. Category 5, no damage, is the desired result in the package drop test. The damage to two of the M831E2 cartridges after the 7-ft packaged drop are shown in figures 11 and 12 and figures 13 through 15 show the damage to three of the M831 cartridges.

Examination of table 2 shows that in the hot drop test two M831E2 cartridges, 13A* and 37A*, were damaged in the severe categories of 1 and 3 respectively. Two M831E2 cartridges, 14A* and 15A*, were damaged in the less severe category 4. Two cartridges, 36A* and 38A*, were undamaged. Two M831 cartridges were dropped as comparison in the same test and were damaged severely with case bulging and cracking. Results of the M831 are not shown in table 2, since this would make the table difficult to read.

The results in the cold test (table 2) show that five M831E2 cartridges were damaged severely out of the eight that were dropped. Two cartridges had category 1, separation, and three cartridges had category 2, 360 deg crack at projectile/cap interface, damage. Three cartridges were undamaged. Two M831 cartridges were dropped as comparison and were severely damaged with bulging and large cracks along the side of the cartridge case.

Analyzing the data from table 2 shows that the cold drop test was more severe than the hot. The most severe orientations are the base down, horizontal, and nose down.

An examination of the PA116 container with the M831 cartridge (fig. 3) shows that there is no support at the projectiles/case cap interface and no support to the spike. To enhance the existing packaging a projectile/case cap support made of polyethylene foam and a spike donut (figs. 7 and 9) made of the same material were manufactured for a package enhancement drop test study. Two densities, 4 and 6 lb/ft³ were chosen as the best options because of their use in current packaging.

A -46°C (this temperature was chosen since it was the worst case) package enhancement 7-ft drop test was conducted at APG on 21 February 1992, to determine if the polyethylene foam support or donut improved the survivability of the combustible case. The drop sequence for M831E2 package enhancement test, shown in table 3,

illustrates the package enhancement drop test. Fourteen M831E2 packaged cartridges were dropped, each in three orientations: horizontal, nose down, and base down, respectively. The cartridges were examined for damage after the three drops were completed.

To examine each support or donut separately the first 11 dropped were packaged with different supports (table 3) or donuts before being temperature conditioned. The first two packages dropped contained the 6 lb/ft³ polyethylene foam nose donut which was attached to the nose of the spike on the cartridge and slid into the PA116 container. The third and fourth contained a 4 lb/ft³ nose donut. Packages five through 7 contained a 6 lb/ft³ polyethylene projectile/case cap support. This support had a longitudinal slit down the side so that it could be pulled apart, placed on the cartridge case cap interface, and then taped together with duct tape and slid into the PA116 container. The eighth and ninth cartridges contained a 4 lb/ft³ polyethylene projectile/case cap support. The 10th cartridge did not have a support added, but did have a radius added to the stabilizer at its interface area with the case cap. This was done to see if this radius would prevent any cracking of the cap in this area. The last four packages were reserved for the support which showed the most promise. As shown in table 3 the 6 lb/ft³ projectile case cap support was used for drops 11 through 15, completing the 7-ft package enhancement cold drop test. A combination of the nose donut and projectile/case cap support was not considered since this option would not be practical for field use because it would be too expensive and make the cartridge difficult to pull free from the container.

RESULTS

The results of the cold (-46°C) 7-ft package enhancement drop test are shown in table 4. Each package was dropped three times in the horizontal, nose down, and base down orientation and then examined for damage.

The two rounds with the 6 lb/ft³ nose donut were both severely damaged. The two rounds with the 4 lb nose donut were severely damaged.

The two rounds with the 4 lb/ft³ projectile/case cap support had some damage, but much less severe. The seven rounds with the 6 lb/ft³ projectile/case cap support increased the survivability of the M831E2 cartridges in the 7-ft cold packaged drop test considerably. Comparison of the two tables show that the cartridges without the package support (table 2) were each dropped twice and had three out of six M831E2 cartridges severely damaged, whereas, the cartridges with the support (table 4) were dropped three times and had only one out of seven severely damaged.

CONCLUSIONS AND RECOMMENDATIONS

1. The 6 lb/ft³ projectile/case cap support when added to the existing packaging substantially increased the survivability of the M831E2 in the cold 7-ft packaged drop test. The nose donut did not provide any additional protection whatsoever.
2. Further testing needs to be performed to study the survivability increased for the M831 and M830 cartridges with the support added in the 7-ft package drop test.
3. The projectile/case cap support needs to be modified so that it can be glued into the existing PA116 container cushion assembly and allow the M830, M831, and M831E2 to be inserted and removed easily from the packaging while still providing increased survivability to the cartridge in the 7-ft packaged drop test.

Table 1. Properties of unfabricated Ethafoam* brand products

| Typical Properties of Unfabricated ETHAFOAM® Brand Products (Not to be Considered Product Specification Limits) | | | | | | | | | | |
|--|--|--------|--------|--------------------------|--------------------------|---|--------------------------------------|-------------------------------------|---------------------------|--|
| Product | Compressive Strength (psi) Vertical direction | | | Tensile Strength (psi) | Tensile Elongation (%) | Tear Strength (lb/in) Extruded Direction | Average Density (pcf) | Maximum Cell Size (mm) | Buoyancy (pcf) | Thermal Conductivity at 75°F Mean Temperature (BTU-in/hr-sq ft degree F) |
| Test Procedure | ASTM D 3575-84 Test D | | | ASTM D 3575-84 Test T | ASTM D 3575-84 Test T | ASTM D 3575-84 Test G | ASTM D 3575-84 Test W Method B | ASTM D 3576-84 Dow modified | ASTM D 3575-84 Test AA | ASTM D 3575-84 Test V Method B |
| | at 10% | at 25% | at 50% | | | | | | | |
| ETHAFOAM 200 LC Plank | 4 | 6 | 9 | 40 | 54 | 14 | 1.9 | 4.0 | 58 | 0.57 |
| ETHAFOAM 220 Plank | 7 | 10 | 17 | 48 | 49 | 15 | 2.2 | 1.9 | 59 | 0.43 |
| ETHAFOAM 220 Anti-Static Plank | 6 | 10 | 17 | 48 | 49 | 15 | 2.2 | 1.9 | 59 | 0.43 |
| ETHAFOAM 4101 Plank | 6 | 8 | 16 | 45 | 61 | 13 | 2.5 | 1.9 | 59 | 0.39 |
| ETHAFOAM HS-45 Plank | 12 | 14 | 23 | 67 | 44 | 21 | 3.8 | 1.9 | 58 | 0.38 |
| ETHAFOAM HS-600 Plank | 21 | 26 | 45 | 108 | 44 | 30 | 6.6 | 1.5 | 55 | 0.36 |
| ETHAFOAM HS-900 Plank | 50 | 58 | 90 | 178 | 31 | 51 | 9.5 | 1.5 | 52 | 0.40 |
| ETHAFOAM 221 Sheet | 1 | 1 | 12 | 56 | 85 | 18 | 1.7 | 2.8 | 58 | 0.39 |
| ETHAFOAM 221 Anti-Static Sheet | 1 | 1 | 11 | 71 | 76 | 18 | 1.7 | 2.8 | 58 | 0.39 |
| ETHAFOAM 222 Sheet | 3 | 3 | 15 | 60 | 56 | 19 | 2.5 | 1/2 = 1.2 1/4 = 1.3 1/2 = 1.7 | 59 | 0.37 |

*Trademark of Dow Chemical Company.

Table 2. M831E2 metal can 7-ft drop test results

Damage to cartridge

| (1) <u>Separation</u> | (2) <u>360 crack at projectile/cap interface</u> | (3) <u>Interface crack and longitudinal crack</u> | (4) <u>Slight crack interface</u> | (5) <u>No damage</u> |
|--------------------------|---|--|--|-----------------------------|
|--------------------------|---|--|--|-----------------------------|

Hot (18 Jan 92)

| | | | | |
|----------|------|------|------------|------------|
| Round | 13A* | 37A* | 14A*, 15A* | 36A*, 38A* |
| Position | B/B | N/N | B/H, H/H | H/B, N/H |

Cold (16 and 17 Jan 92)

| | | | | |
|----------|------------|--------------------|--|---------------------|
| Round | 40A*, 33A* | 9A*, 39A*, 35A* | | 10A*, 32A*, 34A* |
| Position | N/H, H/H | H/N, N/N, H/B | | B/B, B/B, B/H |

where:

N = Nose orientation
H = Horizontal orientation
B = Base orientation

Table 3. Drop sequence for M831E2 package enhancement test

| <u>Round</u> | <u>Fix</u> | <u>Cold (-46°C) orientations</u> | | |
|--------------|---------------------|--------------------------------------|-------------|-------------|
| | | <u>Horizontal</u> | <u>Nose</u> | <u>Base</u> |
| 1 | 6# nose donut | X | X | X |
| 2 | 6# nose donut | X | X | X |
| 3 | 4# nose donut | X | X | X |
| 4 | 4# nose donut | X | X | X |
| 5 | 6# case cap support | X | X | X |
| 6 | 6# case cap support | X | X | X |
| 7 | 6# case cap support | X | X | X |
| 8 | 4# case cap support | X | X | X |
| 9 | 4# case cap support | X | X | X |
| 10 | Stab, radius | X | X | X |
| 11 | 6# case cap support | X | X | X |
| 12 | 6# case cap support | X | X | X |
| 13 | 6# case cap support | X | X | X |
| 14 | 6# case cap support | X | X | X |

**Table 4. Seven foot, -46°C, M831E2, package enhancement drop test results,
21 February 1992**

| Fix | Damage to cartridge* | | | | |
|---------------------------------------|---|--|---|--|---------------------|
| | (1) Separation of projectile | (2) 360 crack at projectile/cap interface | (3) Interface crack and longitudinal crack | (4) Slight crack and/or bulge | (5) None |
| 6 lb nose donut | | X | X | | |
| 4 lb nose donut | X | | X | | |
| 6 lb cap donut | X | | | X | X,X,X X,X |
| 4 lb cap donut | | | | X, X | |
| Stabilizer radius | X | | | | |
| M831 control cartridge | | | | | |

*Damage columns 1 through 3 are considered undesirable results for this test and columns 4 and 5 are considered desirable results with a preference for column 5.

Cartridge, 120MM, HEAT-MP-T, M830

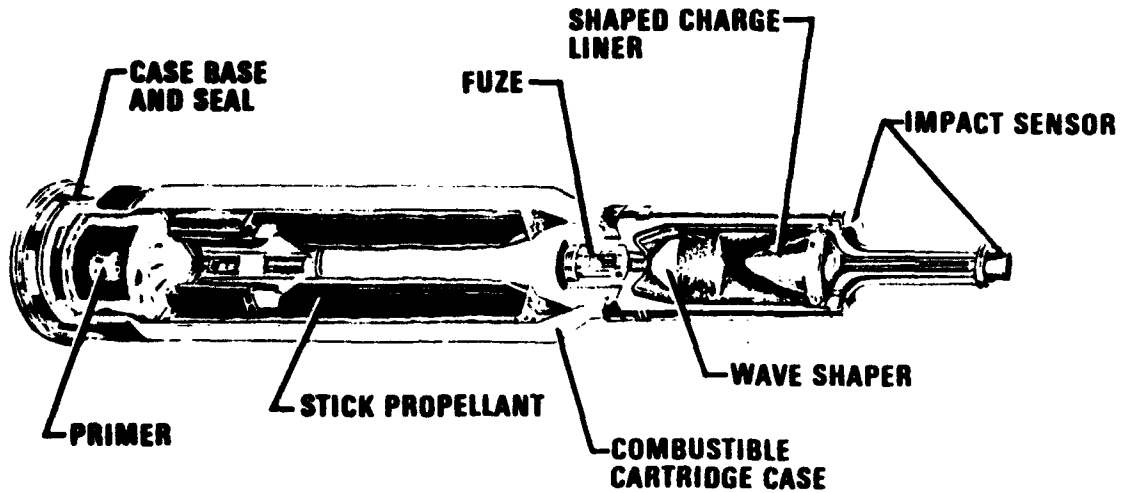

Cartridge, 120MM, TP-T, M831

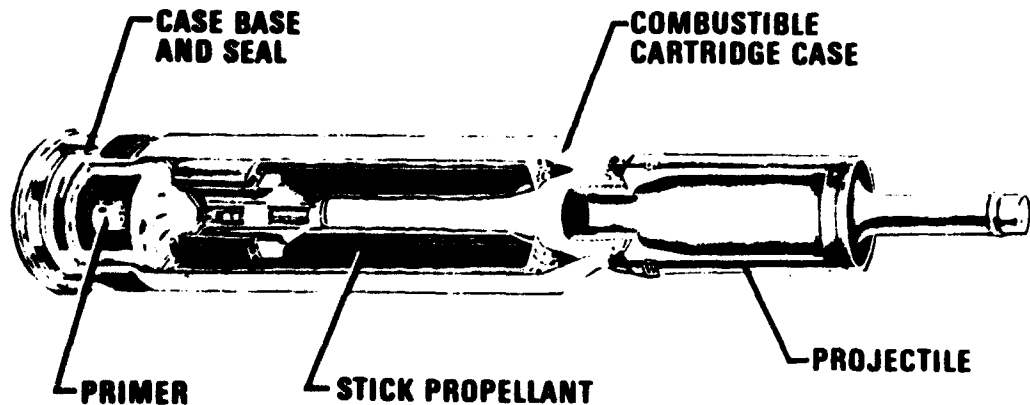

Figure 1. Cartridge, 120-mm, HEAT-MP-T, M830 and cartridge, 120-mm TP-T, M831

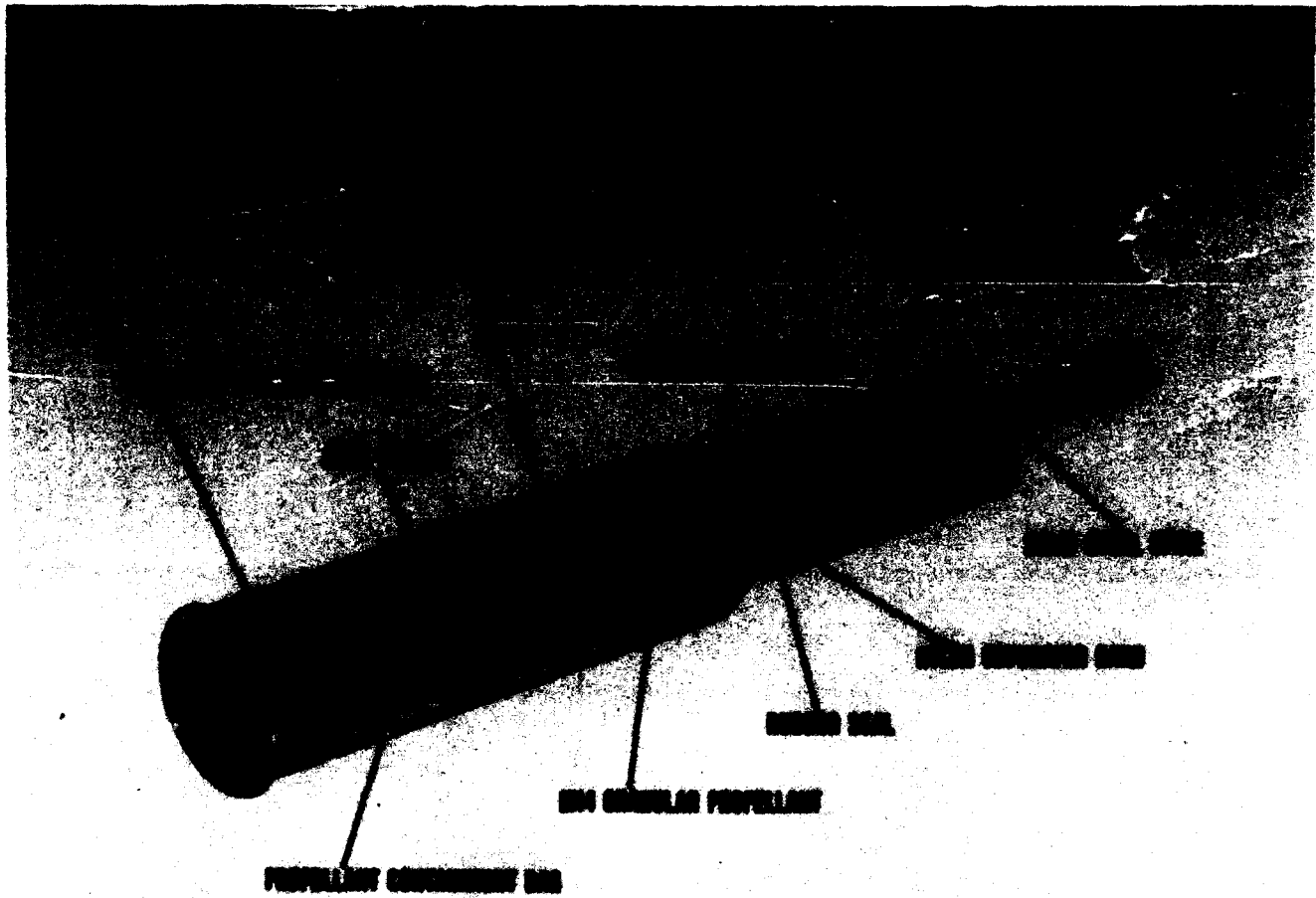

Figure 2. Cartridge, 120-mm, TP-T, M831E2

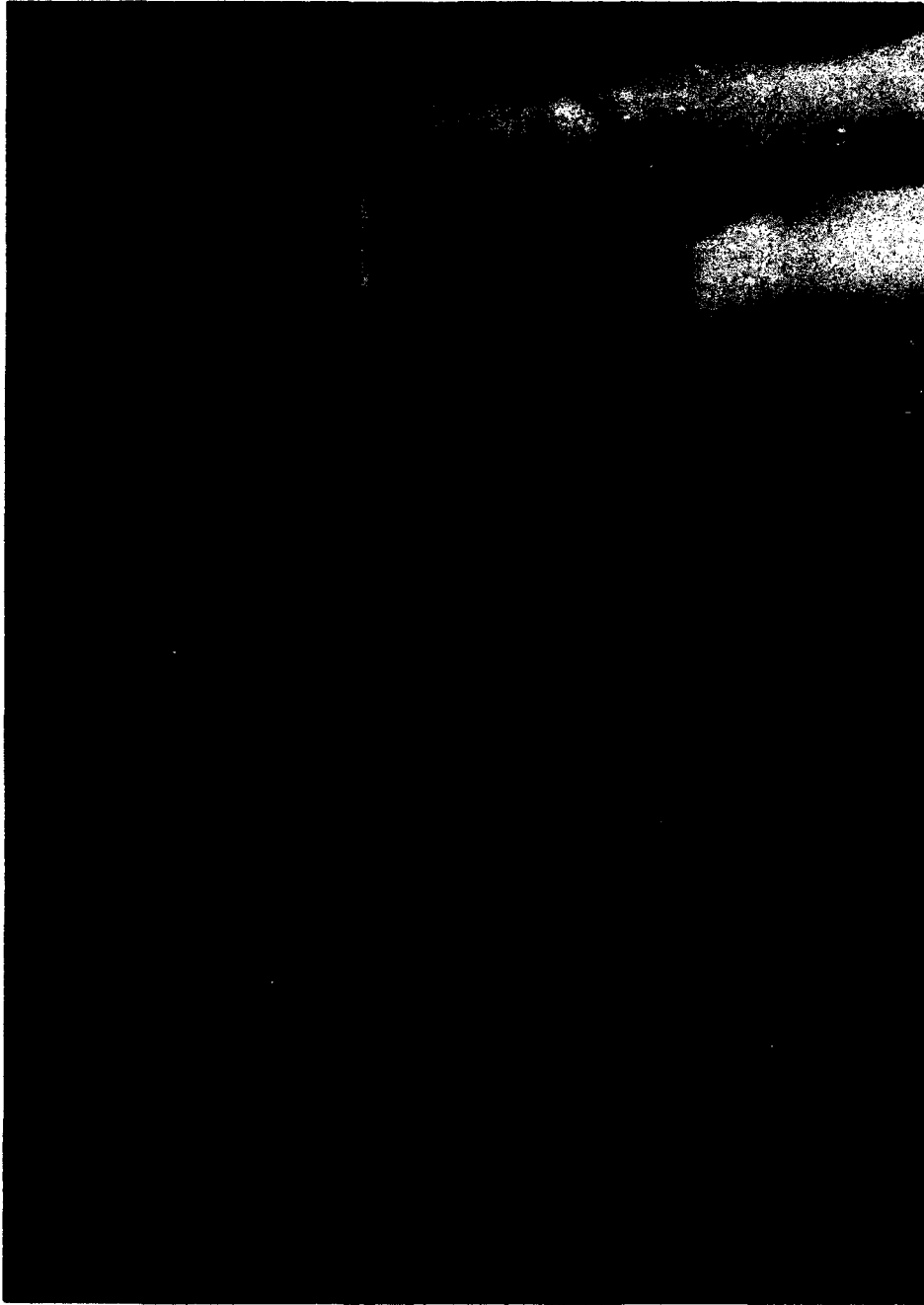

Figure 4. PA116 container and internal supports

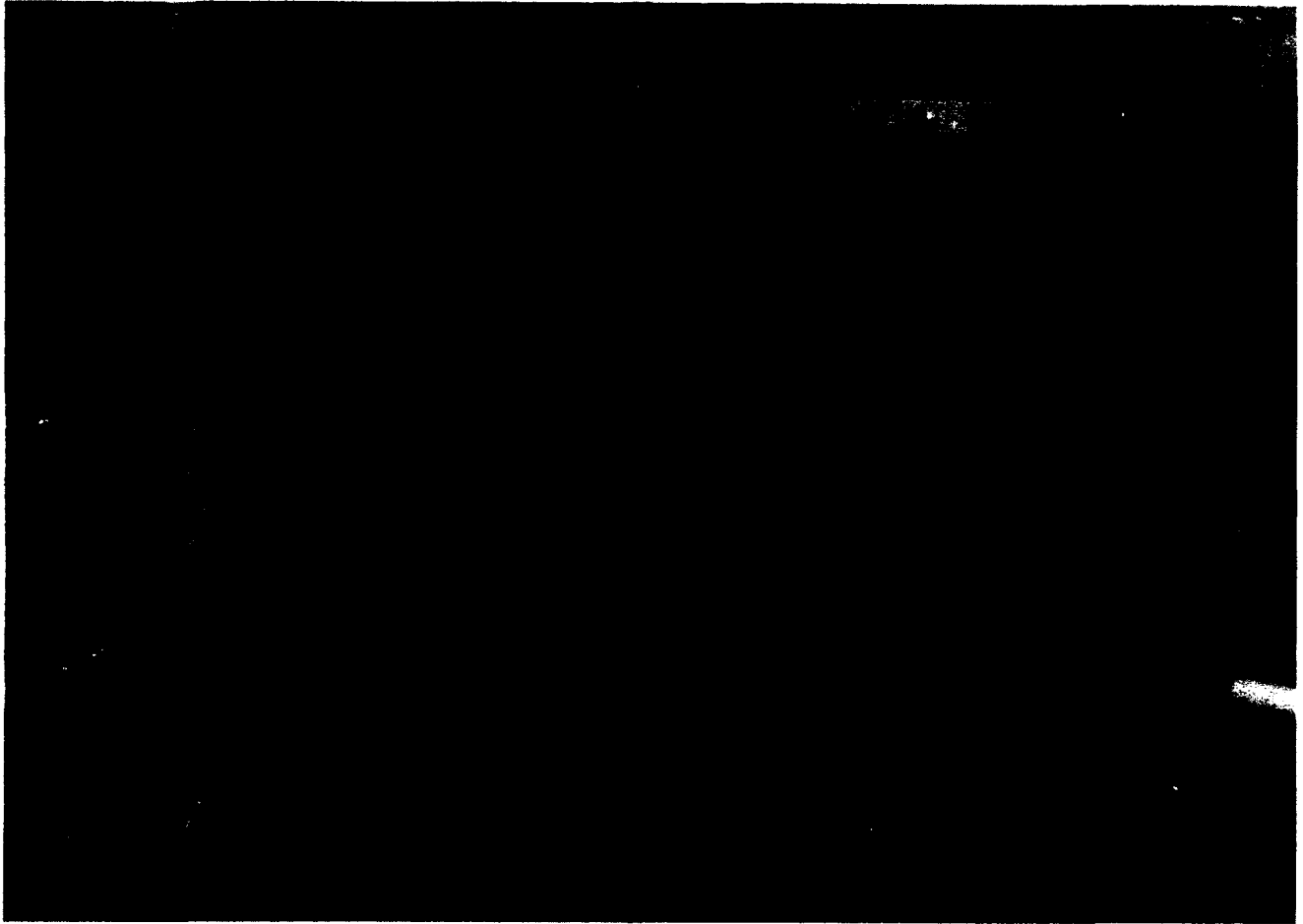

Figure 5. Aberdeen Proving Ground 7-ft drop site

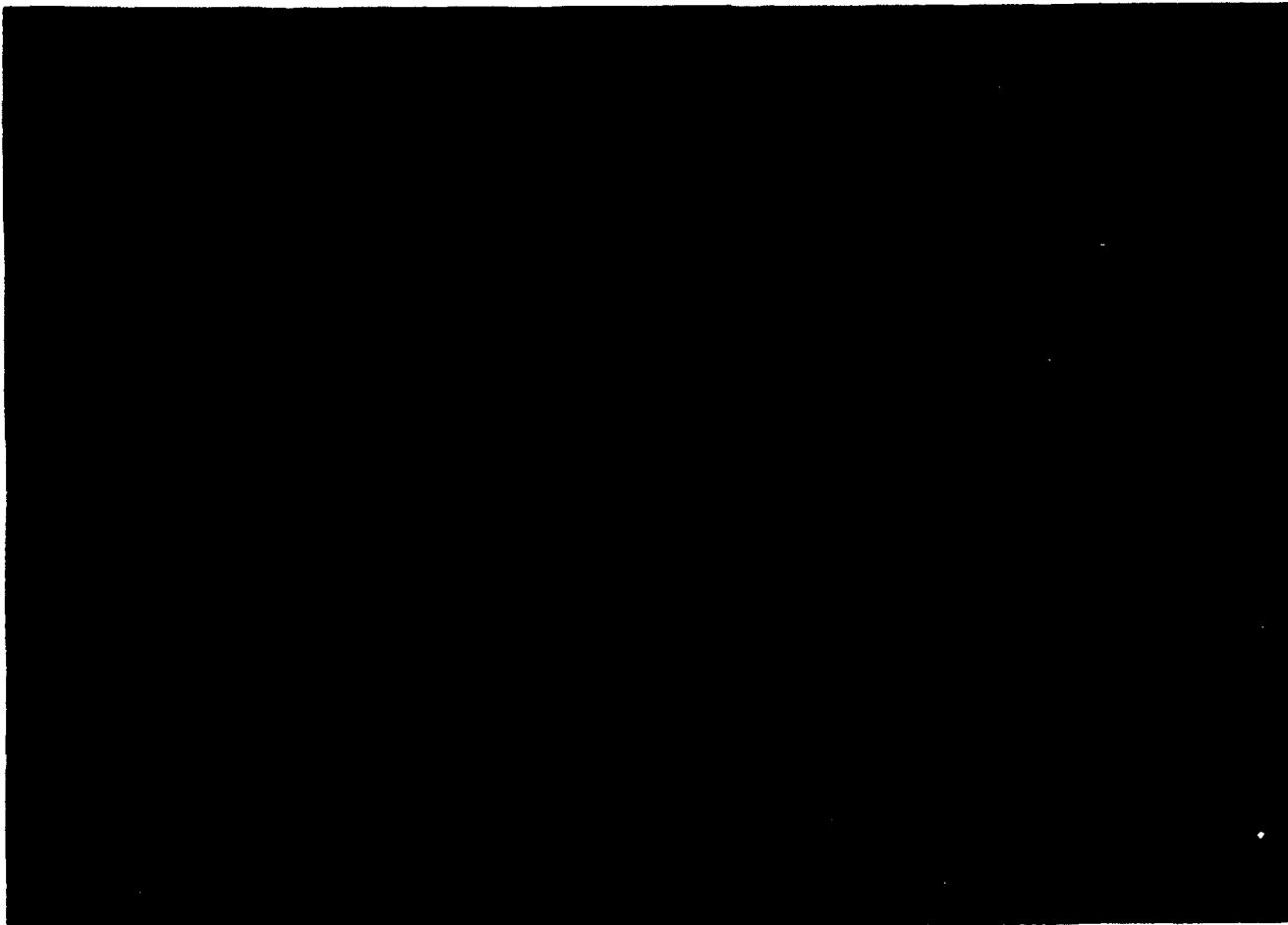

Figure 6. Aberdeen Proving Ground 7-ft drop set-up with containers in nose down orientation before being lifted to 7 ft

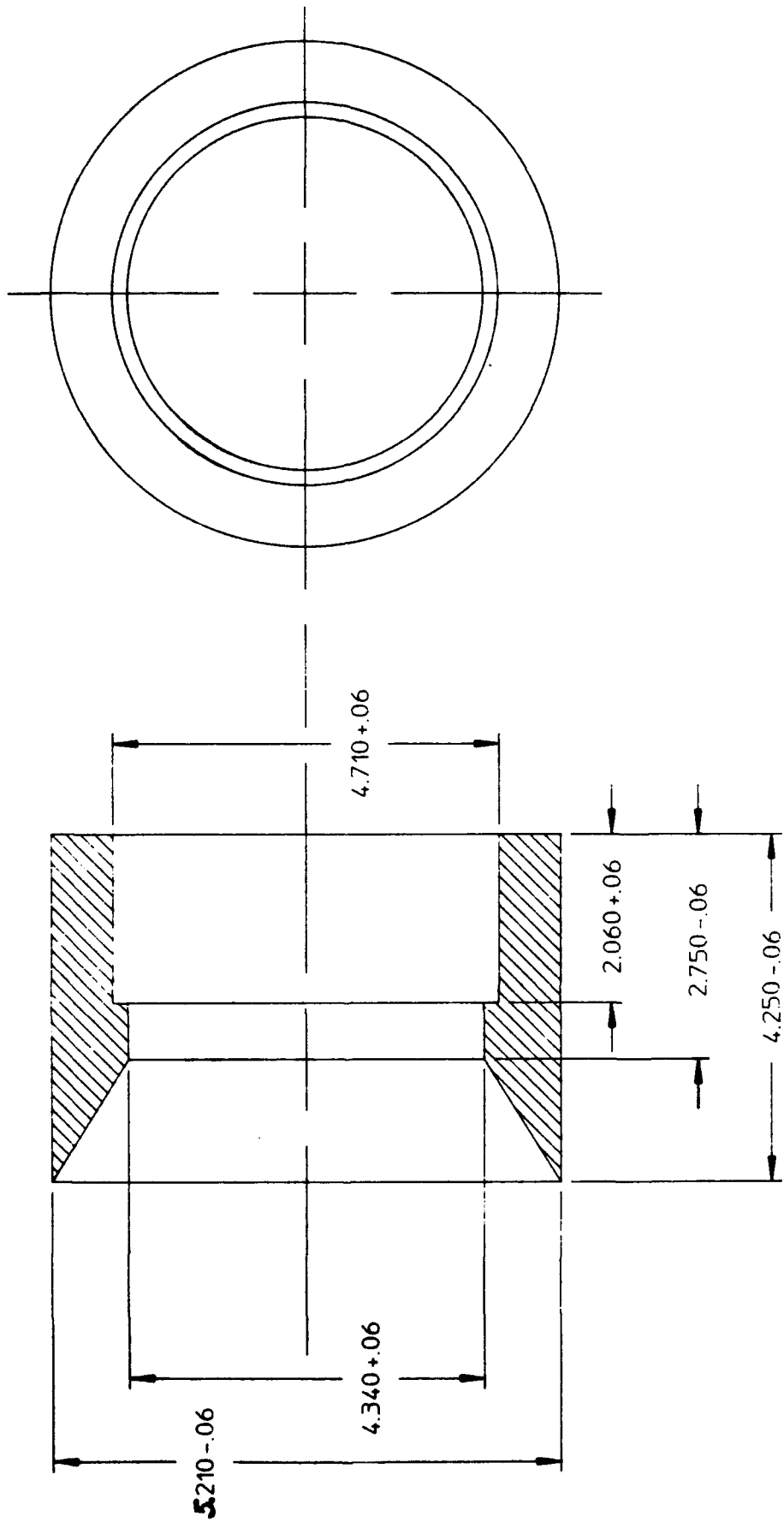

Figure 7. Case cap support drawing

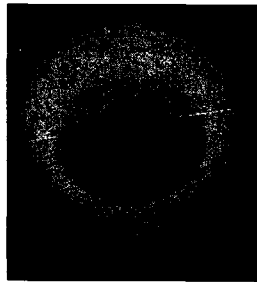

Figure 8. Case cap support

NOTE.

1. MATERIAL: A - 4 LBS. POLYETHYLENE FOAM.
B - 6 LBS. POLYETHYLENE FOAM.
C - 8 LBS. POLYETHYLENE FOAM.

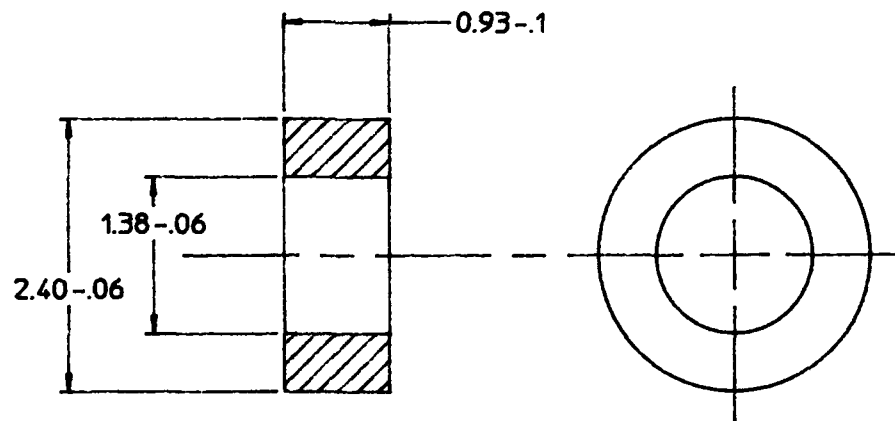

Figure 9. Spike donut drawing

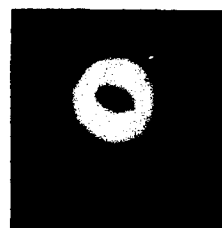

Figure 10. Spike donut

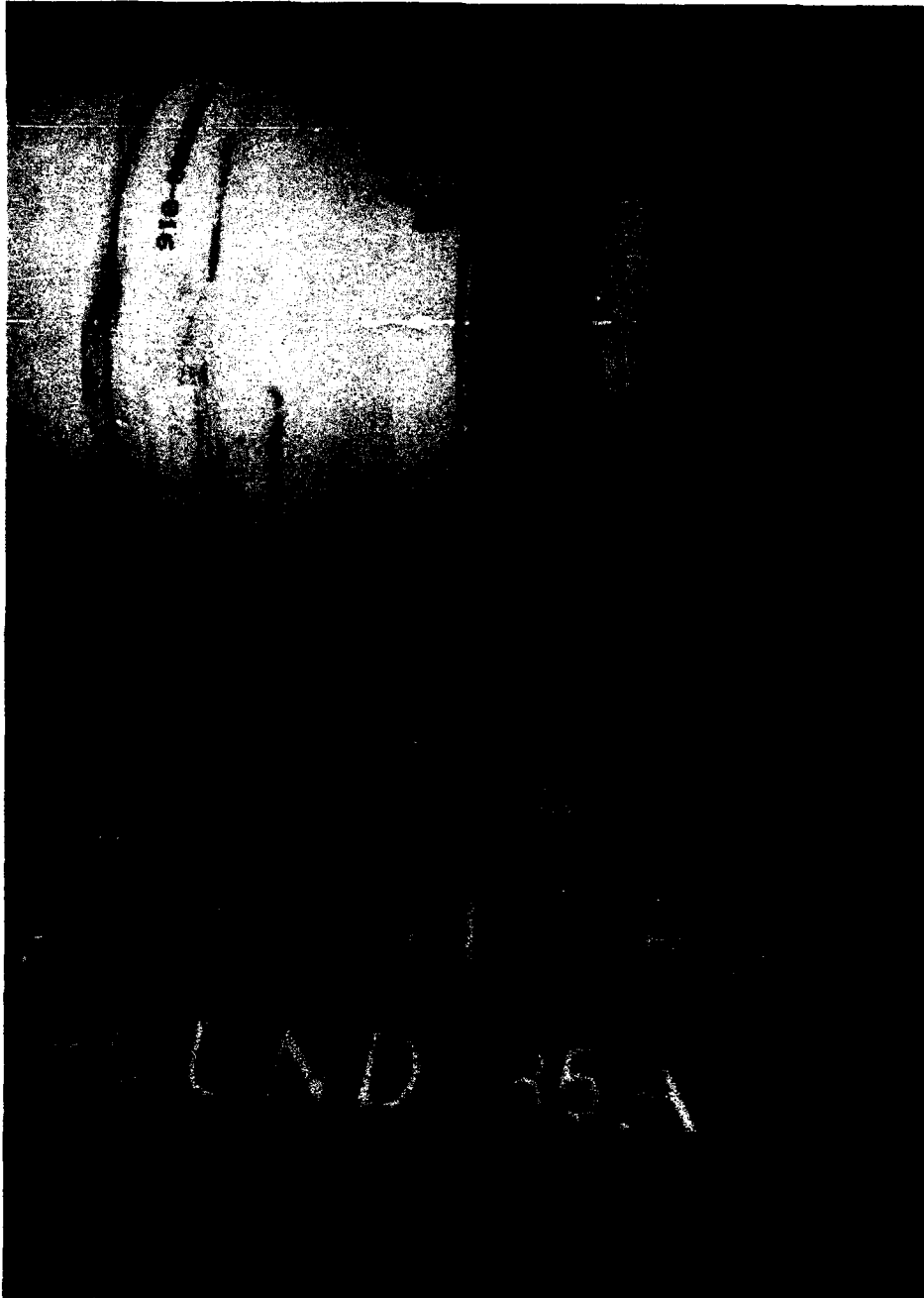

Figure 11. M831E2 cartridge after 7-ft packaged drop test at -46°C, cartridge case cracked at case cap/projectile interface

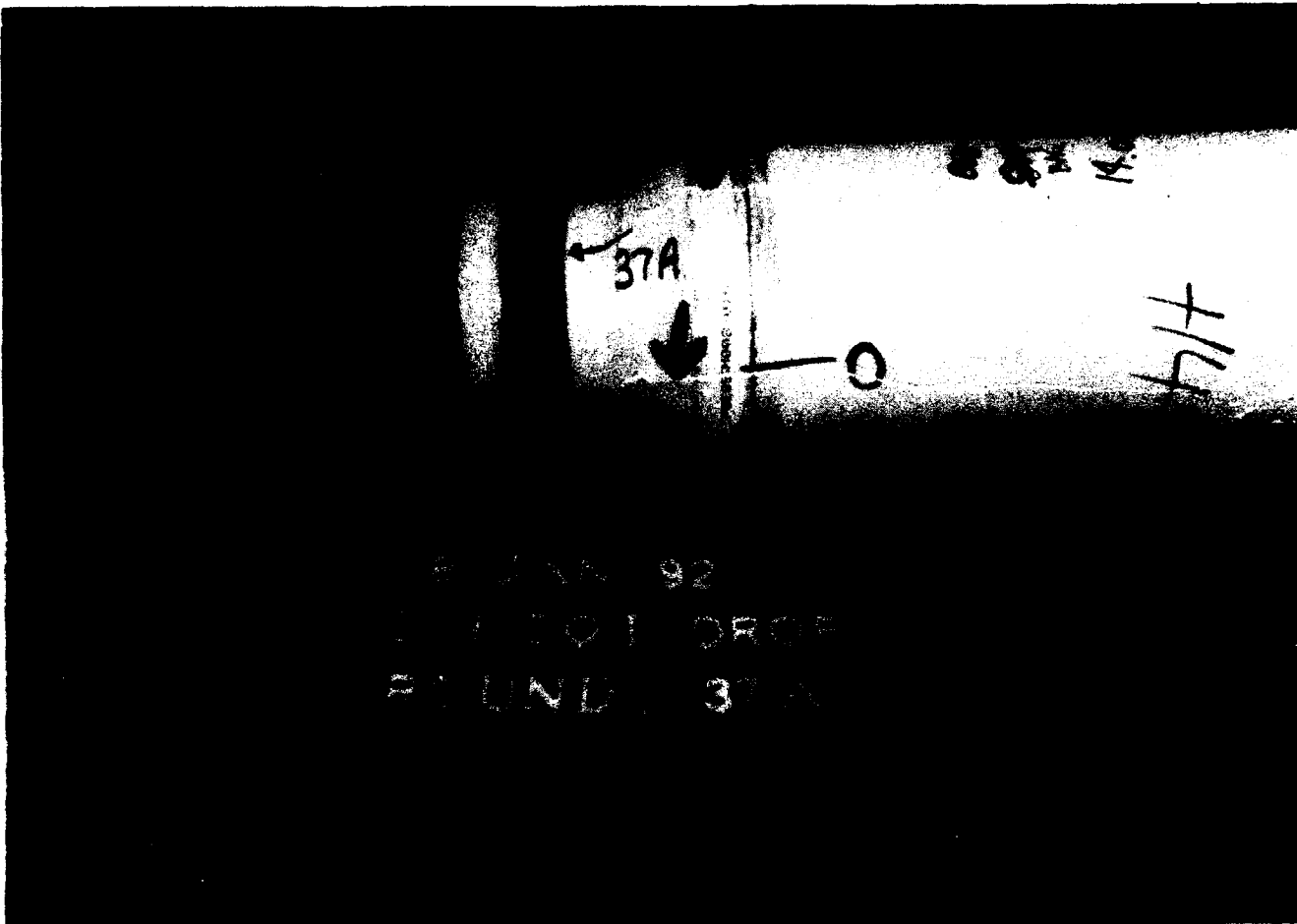

Figure 12. M831E2 cartridge after 7-ft packaged drop test at -46°C, two cracks along cartridge case



Figure 13. M831 cartridge after 7-ft packaged drop test at -46°C, crack in case cap and cracks in cartridge case caused by internal fin

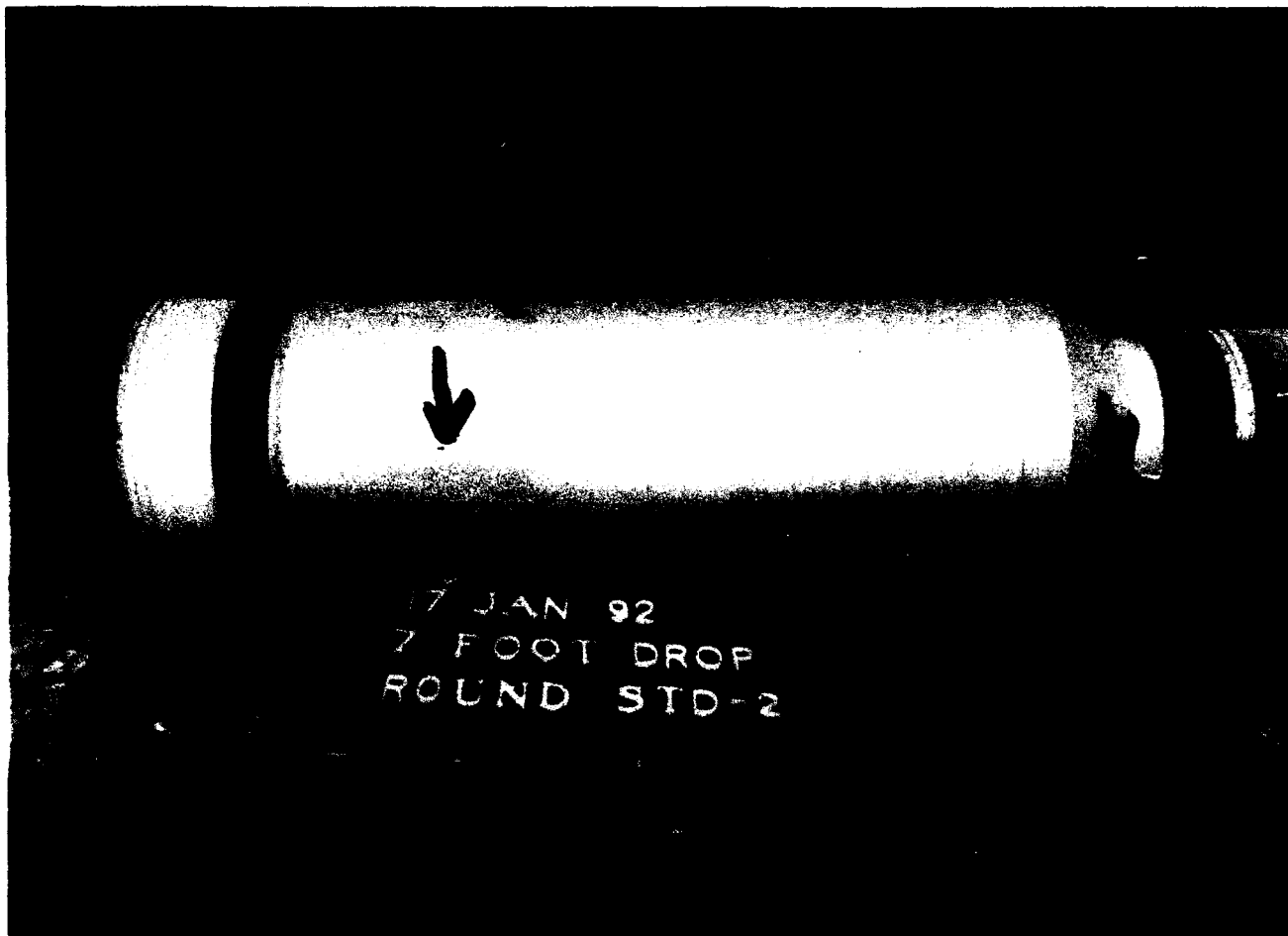

Figure 14. M831 cartridge after 7-ft packaged drop test at -46°C, crack in case cap and bulge/crack in cartridge case cap

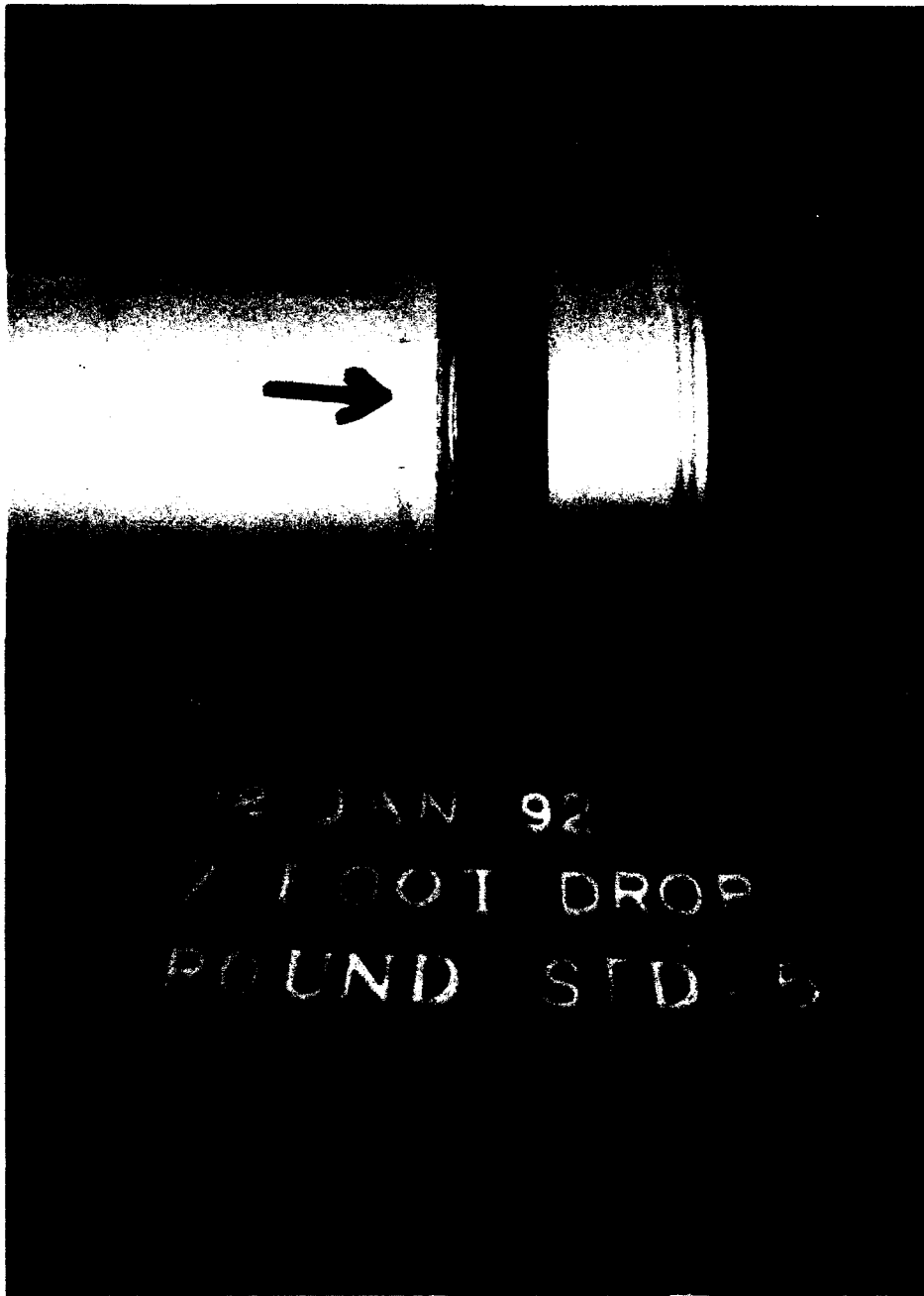

Figure 15. M831 cartridge after 7-ft packaged drop test at -46°C, bulge in cartridge case

DISTRIBUTION LIST

Commander

**Armament Research, Development and Engineering Center
U.S. Army Armament, Munitions and Chemical Command**

**ATTN: SMCAR-IMI-I (5)
SMCAR-AEE
SMCAR-AEP
SMCAR-CCH-V (10)
SMCAR-QAA
SMCAR-QAR-R
SMCAR-QAT**

Picatinny Arsenal, NJ 07806-5000

Commander

U.S. Army Armament, Munitions and Chemical Command

**ATTN: AMSMC-GCL (D)
Picatinny Arsenal, NJ 07806-5000**

Administrator

Defense Technical Information Center

**ATTN: Accessions Division (12)
Cameron Station
Alexandria, VA 22304-6145**

Director

U.S. Army Material Systems Analysis Activity

**ATTN: AMXSY-MP
Aberdeen Proving Ground, MD 21005-5066**

Commander

**Chemical Research, Development and Engineering Center
U.S. Army Armament, Munitions and Chemical Command**

**ATTN: SMCCR-MSI
Aberdeen Proving Ground, MD 21010-5423**

Commander

**Chemical Research, Development and Engineering Center
U.S. Army Armament, Munitions and Chemical Command**

**ATTN: SMCCR-RSP-A
Aberdeen Proving Ground, MD 21010-5423**

Director
Ballistic Research Laboratory
ATTN: AMXBR-OD-ST
Aberdeen Proving Ground, MD 21005-5066

Chief
Benet Weapons Laboratory, CCAC
Armament Research, Development and Engineering Center
U.S. Army Armament, Munitions and Chemical Command
ATTN: SMCAR-CCB-TL
Watervliet, NY 12189-5000

Commander
U.S. Army Rock Island Arsenal
ATTN: SMCRI-TI, Technical Library
Rock Island, IL 61299-6000

Director
U.S. Army TRADOC Systems Analysis Activity
ATTN: ATAA-SL
White Sands Missile Range, NM 88002