

REPORT DOCUMENT

AD-A256 643

Form Approved
 VB No. 0704-0188

2

Public reporting burden for this collection of information is estimated to average 1 hour per response, including the time for reviewing instructions, searching existing data sources, gathering and maintaining the data needed, and completing and reviewing the collection of information, including suggestions for reducing this burden. Send comments to Washington Headquarters Service, Paperwork Project, Washington, DC 20503.



Do not search existing data sources, estimate or any other aspect of this report and Report, 1215 Jefferson Avenue, Washington, DC 20503.

1. AGENCY USE ONLY (Leave blank) 2. REPORT DATE
 15 Sep 92 Final Tech 01Sep89 to 30Jun92

4. TITLE AND SUBTITLE
 Nanograin Superplasticity in Ceramics

5. FUNDING NUMBERS
 DAAL03-89-K-0132

6. AUTHOR(S)
 Rishi Raj

SD TIC
ELECTE
 OCT 22 1992
C

7. PERFORMING ORGANIZATION NAME(S) AND ADDRESS(ES)
 Cornell University
 Department of Materials Science and Engineering
 Ithaca NY 15853-1501

8. PERFORMING ORGANIZATION REPORT NUMBER
 AROFINAL92

9. SPONSORING/MONITORING AGENCY NAME(S) AND ADDRESS(ES)
 US Army Research Office
 P. O. Box 12211
 Research Triangle Park NC 27709-2211
 Attn: Dr. Wilbur Simmons

10. SPONSORING/MONITORING AGENCY REPORT NUMBER
 ARO 26747.2-MS-A

11. STATEMENT OF WORKING NOTES
 The view, opinions and/or findings contained in this report are those of the author(s) and should not be construed as an official Department of the Army position, policy, or decision, unless so designated by other documentation.

12a. DISTRIBUTION/AVAILABILITY STATEMENT
 Approved for public release; distribution unlimited.

403152
 92-27570

 1184

13. ABSTRACT (Maximum 200 words)
 The objective of this research program has been to understand whether or not nanograin ceramic materials are capable of exhibiting unusual superplasticity, and if so, then is this phenomenon general or is it limited to a few special types of ceramics. The first part of the research required implementation of the method to process high quality, glass-free ceramic specimens from different chemistries and to test their superplastic properties at over a wide range of high temperatures and strain rates. The PVD method combined with lithography was chosen and developed for making specimens from different ceramic materials. The report summarizes the results from ultrafinegrained specimens of magnesium aluminate spinel and yttria-stabilized zirconia. After testing many different compositions we have found that so far only these two (glass free ceramics) are capable of sustaining substantial superplastic strain in tensile deformation. These results point toward the possibility that interfaces in non-stoichiometric ceramics have greater resistance to fracture than in stoichiometric ceramics.

14. SUBJECT TERMS
 Nanocrystalline, ceramics, superplasticity, PVD, Vapor Deposition, Interfaces

15. NUMBER OF PAGES
 84 Figs
 16. PRICE CODE

17. SECURITY CLASSIFICATION OF REPORT
 Unclassified

18. SECURITY CLASSIFICATION OF THIS PAGE
 Unclassified

19. SECURITY CLASSIFICATION OF ABSTRACT
 Unclassified

20. LIMITATION OF ABSTRACT
 SAR

Nanograin Superplasticity in Ceramics

R. Raj

Department of Materials Science and Engineering

Cornell University

Ithaca NY 14853-1501

Tel: 607/255-4040

Fax: 607/255-2365

Accession Number	
NTIS GRA&I	<input checked="" type="checkbox"/>
DTIC TAB	<input type="checkbox"/>
Unannounced	<input type="checkbox"/>
Justification	
By	
Distribution/	
Availability	
Ann. for	
Dist	Special
A-1	

DTIC QUALITY

Abstract

The objective of this research program has been to understand whether or not nanograin ceramic materials are capable of exhibiting unusual superplasticity, and if so, then is this phenomenon general or is it limited to a few special types of ceramics. The first part of the research required implementation of the method to process high quality, glass-free ceramic specimens from different chemistries and to test their superplastic properties at over a wide range of high temperatures and strain rates. The PVD method combined with lithography was chosen and developed for making specimens from different ceramic materials. The report summarizes the results from ultrafinegrained specimens of magnesium aluminate spinel and yttria-stabilized zirconia. After testing many different compositions we have found that so far only these two ceramics (those that do not contain a glass phase at grain boundaries) are capable of sustaining substantial superplastic strain in tensile deformation. These results point toward the possibility that interfaces in non-stoichiometric ceramics have greater resistance to fracture than in stoichiometric ceramics.

Summary of Accomplishment

Specimen Preparation and Testing

We have developed a powder free method for making fine grained ceramics. The procedure consists of vapor deposition of the constituents in an amorphous form followed by heat treatment at relatively low temperatures to crystallize the material into a uniform grain structure. The grain size may be controlled by varying the heat treatment and by the use of grain refining agents. For example, the use of platinum or rhenium as crystallization agents lowers the crystallization temperature to about 200 °C, whereas pure spinel crystallizes only when heated above 800 °C.

Specimens for mechanical testing are prepared by lithography leading to the geometry that is described in Fig. 1. The procedure yields nearly one thousand specimens with different sizes in one preparation cycle. The gage section of these dog-bone shaped specimens has a cross section of about 1.0 μm x 10, 50 μm and a length of 4 mm. The use of small specimens has the advantage that they can be directly examined in the transmission electron microscope and their structure can be examined in many parts of the gage section to check for uniformity.

The disadvantage of the small specimens is that they are difficult to manipulate for mechanical testing. However, we have built a machine that can perform microtensile stress-strain experiments on these free-standing specimens at temperatures that range from room temperature to 1500 °C, and at strain rates that range from $5 \cdot 10^{-3}$ to $5 \cdot 10^{-7}$ s⁻¹, with a high degree of reproducibility. A schematic of the microtensile tester is illustrated in Fig. 2.

We have prepared and tested specimens of the following materials by the above methodology: Al₂O₃, Pt/Al₂O₃, 10-50 % SiO₂/Al₂O₃, 2-10 mol.%

Y_2O_3/ZrO_2 , Pt/ ZrO_2 and 0-14 wt.% Pt,Re/magnesium aluminate spinel. Next we describe results from yttria-stabilized zirconia and magnesium aluminate spinel.

Superplastic Spinel

If we limit ourselves to those ceramics (for structural applications) that do not contain a glass phase¹, then only zirconia based ceramics have been shown to be capable of tensile ductilities of more than 10% in superplastic deformation². Here we show that magnesium aluminate spinel is also capable of similar superplastic behavior.

Magnesium aluminate spinels of composition $MgO.nAl_2O_3$, where $n=0.9-2.3$, and spinels doped with platinum, were made in their amorphous state by physical vapor deposition using dual gun electron beam evaporation. The initial idea of doping spinel with platinum was to enhance interfacial cohesion and improve superplastic elongations. The most obvious effect of the platinum, however, was to refine the grain size during crystallization of the spinel. TEM micrograph of a nanocrystalline specimen of spinel obtained in this way is given in Fig. 3; it has a grain size of 38 nm. In comparison the undoped spinel evolved into a bimodal structure with large grains of ~1000 nm and small grains of 90 nm. Only the the fine grained spinels prepared by Pt doping led to high tensile ductilities. Stress

¹Several glass containing ceramics, most notably silicon-nitride/silicon-carbide composite, have been shown to be capable of tensile superplastic deformation.

²Significant superplastic elongations have been demonstrated in hydroxyapatite, ferroelectric materials, and zinc sulphide, all of whom are functional materials. Composites of silicon carbide and silicon nitride have also been shown to sustain large tensile elongation but this material contained a glass phase at grain boundaries. In one instance alumina doped with yttria has also been deformed in tension but this material shows only transitional deformation behavior. In contrast zirconia and spinel are viable structural materials and appear to be invariably superplastic.

strain curves from such a specimen are shown in Fig. 4. The effect of grain size on the flow stress in the spinel was also examined. The grain size was varied from 500 nm to 75 nm³. This led to a change in the flow stress that was consistent with the diffusional mechanism of superplastic flow. However, the grain size dependence of the flow stress appeared to be weaker than predicted by the simple equation for diffusional creep⁴.

In the initial phase of the study we prepared specimens of yttria stabilized zirconia by the PVD technique to determine whether or not these specimens yielded similar stress-strain response as that obtained in bulk specimens investigated by Wakai. Our results of the stress strain curves as shown in Fig. 5. While these measurements give similar values for the flow stress, they show a highly serrated behavior that is not seen in large specimens. This result is explained by the small size of the specimens. The amplitude of the serrations increases as the specimen size decreases. These experiments show, for the first time, that superplastic flow is not a smooth process but a stochastic mechanism where strain increments occur in short bursts in local domains in the specimen. The size of these domains has been estimated to be approximately ten grain diameters in size.

In summary, we have obtained two new results. We have found magnesium aluminate spinel exhibits unusual tensile superplasticity. And we have

³The grain size in the pure spinel samples was bimodal while in the Pt-doped spinel specimens grains were uniformly small.

⁴The strain rate for simple diffusional creep which is the starting point for the explanation of superplasticity has the following form:

$$\dot{\epsilon} = A \frac{\sigma \Omega}{kT} \frac{\delta D_b}{d^3}$$

where σ is the applied stress, Ω is the atomic volume, δD_b is the boundary width times the diffusion coefficient and d is the grain size.

obtained experimental evidence that shows that superplastic flow consists of short bursts of strain, separated by time. The Cornell work also suggests that ceramics differ in their resistance to fracture during tensile deformation and that it is this resistance that determines the ductility. Furthermore, ceramics that show high ductility also exhibit a threshold stress for superplastic deformation. These new results are leading us to conceptualize new ideas for the mechanism of cohesion at ceramic grain boundaries.

Industrial Liaison

The spinel coatings on metals may be good candidates for abrasion and corrosion resistance at elevated and high temperatures. (It is interesting to note that zirconia is often used as a coating for superalloys in gas turbine applications).

The following specific industrial interactions were initiated but did not have a chance to reach maturity:

- (a) With L. Edwards and Y. Wang (Senior Engineer) at General Motors we had started to examine the use of thin films of spinel and zirconia as high temperature wear resistance coatings for aluminum alloys for applications in pistons. The samples were coated and returned to GM for wear, scuff and corrosion resistance testing. If these tests are successful then coating of real pistons is planned.

- (b) We have received specimens of γ -TiAl from Rockwell International Science Center through Dr. C. C. Bampton. The idea here is to see if the surface of TiAl can be protected with a ceramic film that would prevent oxidation during superplastic forming of the intermetallic;

we believe that this may be possible if both the ceramic film and the intermetallic substrates can deform together super-plastically. The first experiments show that platinum doped spinel coatings significantly improve the oxidation resistance at high temperatures but fail during prolonged exposure. Since this failure may be due to several reasons, such as interfacial reactions, defects in the coating or gas adsorption etc., a detailed study of the failure mechanism is necessary.

Personnel Support:

Post-doctoral Associate: Dr. R. Lappalainen

Graduate Student: A. Pannikkat (Partial support)

Publications:

1. A. Pannikkat, P. Borgeson, D.A. Lilienfeld, R. Lappalainen, H. Msaad and R. Raj, "Ion induced crystallization and grain growth of nanoscale grains in ceramics", Mat. Res. Soc. Symp. Proc. **202**, Pittsburgh, PA, MRS, 1991, p. 633-638.
2. R. Lappalainen and R. Raj, "Microtensile superplasticity in ceramic fibers", Acta Metall. Mater. **39**, 3125-3132(1991).
3. R. Lappalainen and R. Raj, "Superplastic flow in nanograin ceramics", in Superplasticity in Advanced Materials, ed. S. Hori, M. Tokizane and N. Furushiro, The Japan Soc. of Research on Superplasticity, Osaka, 1991, p. 195-204.
4. R. Lappalainen and R. Raj, "Nanograin superplasticity", in Microcomposites and Nanophase Materials, ed. D.C. Van Aken, G.S. Was and A.K. Ghosh, The Minerals, Metals and Materials Soc., Warrendale, PA, 1991, p. 41-51.
5. R. Lappalainen and R. Raj, "Superplastic flow in ceramic microfiber specimens", Mat. Res. Soc. Symp. Proc. **239**, Pittsburgh, PA, MRS,

1991, p. n-(n+5).

6. R. Lappalainen, A. Pannikkat and R. Raj, "Enhancement of tensile ductility in nanograin ceramic through control of interface chemistry", in Materials Processing and Design Through Better Controlling on Grain Boundary Properties Emphasizing Fine Ceramics, Elsevier Science Publishers, 1992, p. m-(m+9).

Patents:

None filed with the U. S. Patent Office. Patent disclosures are on file at the Cornell Research Foundation.

Other:

R. Raj is a co-chairman with Dr. F. Wakai for a symposium on "Superplastic Phenomena in Ceramics, Intermetallics and Composites" which will be held In Tokyo, Japan, August 31, 1993, under the auspices of IUMRS-ICAM-93.

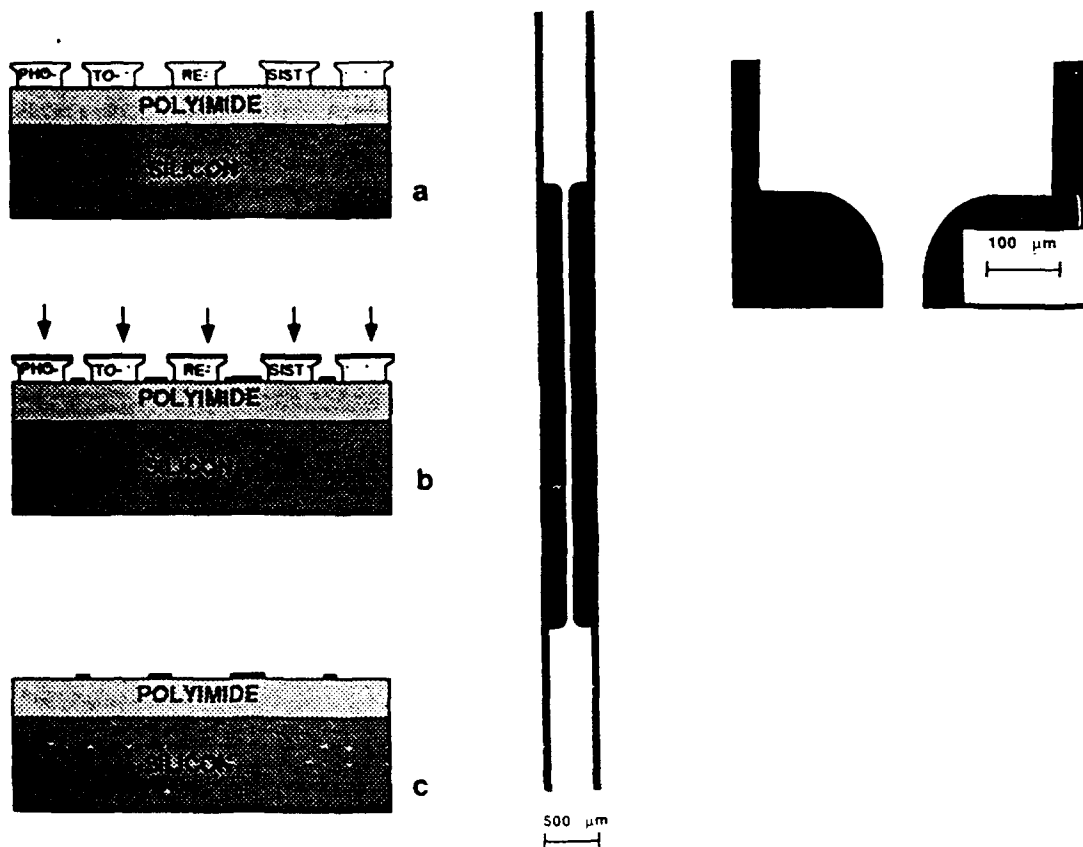

Fig. 1. The photolithographic process used to prepare free-standing fibers for tensile testing. a) a photoresist patterned Si wafer coated with a polyimide film, b) deposition of a ceramic film and c) fibers on the polyimide film which can be dissolved easily. On the right, SEM photographs of a fiber specimen.

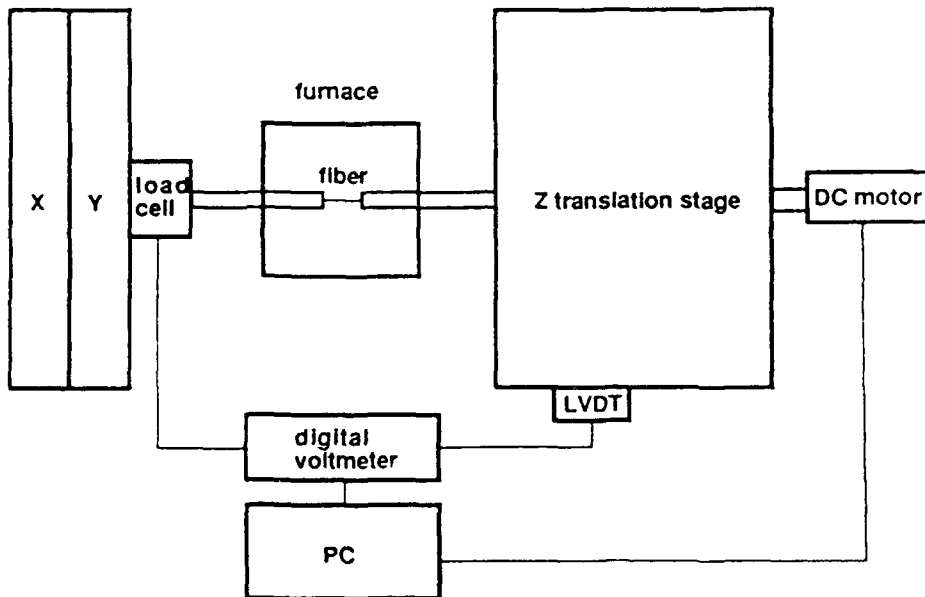

Fig. 2. Schematic of the custom built microtensile tester.

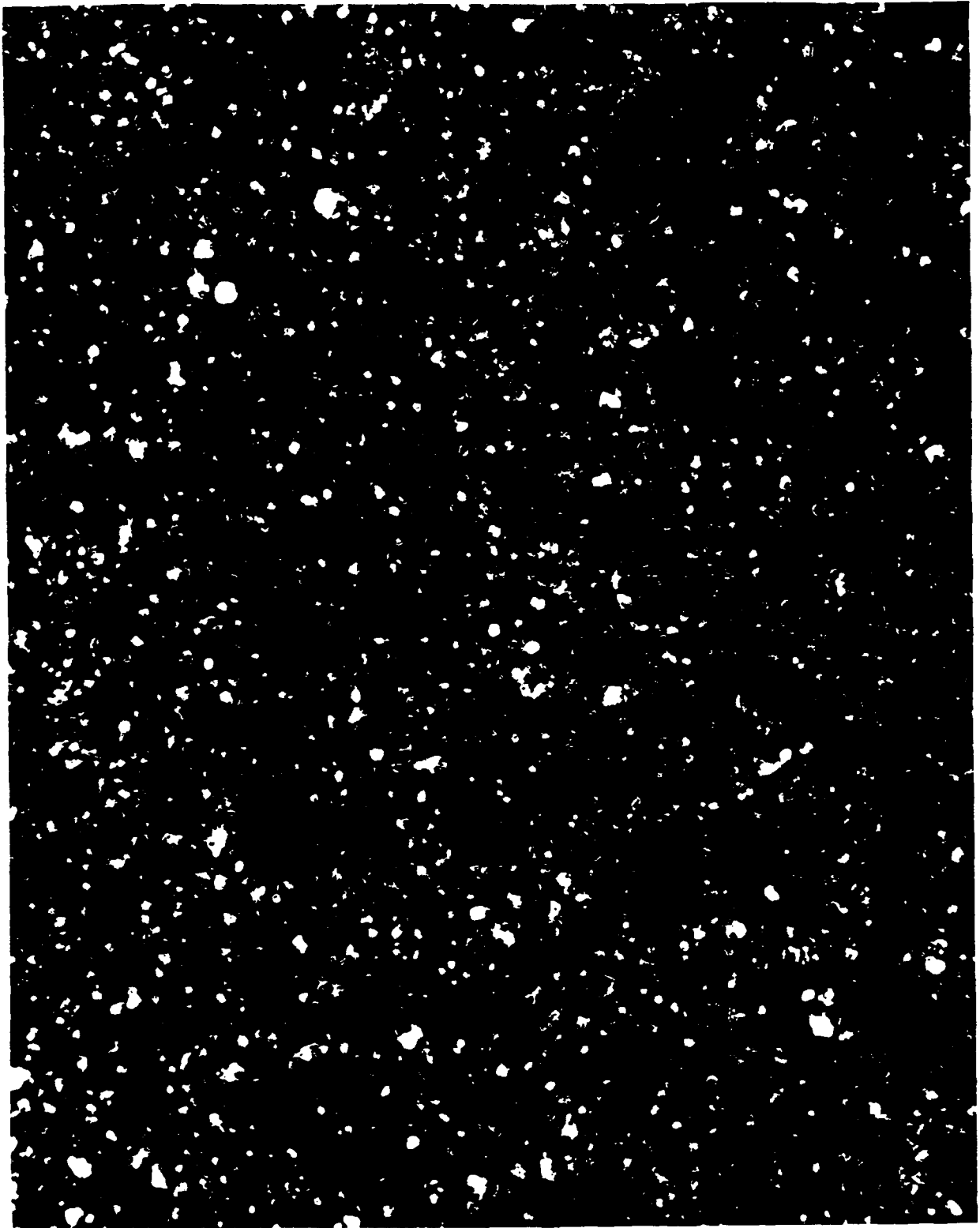

Fig. 3. Nanograin spinel of composition $MgO.1.25Al_2O_3$, having an average grain size of 38 nm. The material was codeposited with 1.3 vol % Pt by PVD in an amorphous form and then annealed at 1100°C to produce the nanocrystalline structure.

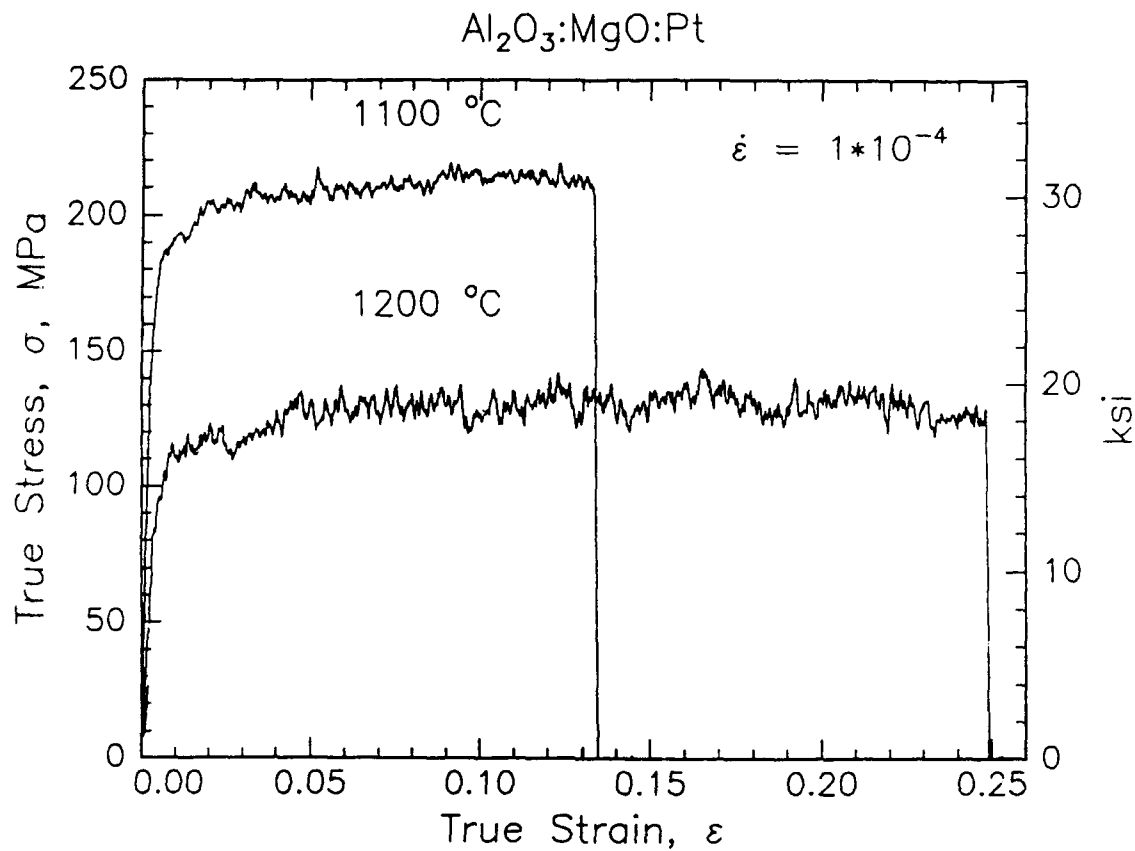

Fig. 4. Tensile stress strain curves for the fine grained spinel specimens having the nanocrystalline grain structure shown in Fig. 3. Note the absence of strain hardening which implies that the grain size remained stable during deformation.

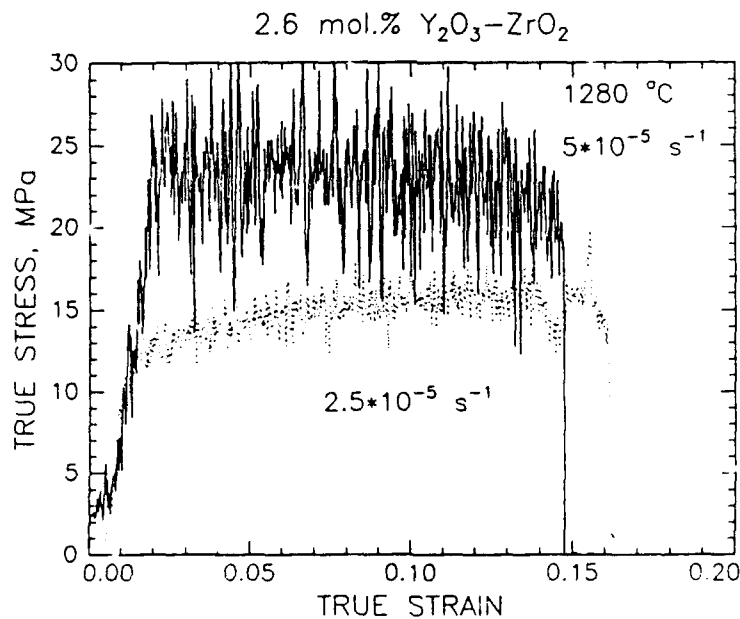

Fig. 5. Tensile stress strain curves for superplastic deformation of yttria stabilized zirconia. The serrated behavior is evidence that superplastic deformation occurs in bursts of strain. The size of the domains participating in these local deformation events is believed to be about ten grain diameters in size.