

AD-A256 830



2

NAVAL POSTGRADUATE SCHOOL Monterey, California



THESIS

SDTIC
ELECTE
NOV 06 1992
E D

Development of an Automated Scanning
Monochromator for Sensitivity
Calibration of the MUSTANG Instrument

by

Thane Damian Rivers

June 1992

Thesis Advisor:

David D. Cleary

Approved for public release; distribution is unlimited.

92-29051



251452 5704

REPORT DOCUMENTATION PAGE				Form Approved OMB No. 0704-0188	
1a REPORT SECURITY CLASSIFICATION UNCLASSIFIED		1b RESTRICTIVE MARKINGS			
2a SECURITY CLASSIFICATION AUTHORITY		3 DISTRIBUTION / AVAILABILITY OF REPORT Approved for public release; Distribution is unlimited.			
2b DECLASSIFICATION / DOWNGRADING SCHEDULE		4 PERFORMING ORGANIZATION REPORT NUMBER(S)			
4 PERFORMING ORGANIZATION REPORT NUMBER(S)		5 MONITORING ORGANIZATION REPORT NUMBER(S)			
6a. NAME OF PERFORMING ORGANIZATION Naval Postgraduate School		6b. OFFICE SYMBOL (If applicable) Code 39		7a. NAME OF MONITORING ORGANIZATION Naval Postgraduate School	
6c. ADDRESS (City, State, and ZIP Code) Monterey CA 93943-5000		7b. ADDRESS (City, State, and ZIP Code) Monterey CA 93943-5000			
8a. NAME OF FUNDING / SPONSORING ORGANIZATION		8b. OFFICE SYMBOL (If applicable)		9 PROCUREMENT INSTRUMENT IDENTIFICATION NUMBER	
8c. ADDRESS (City, State, and ZIP Code)		10 SOURCE OF FUNDING NUMBERS			
		PROGRAM ELEMENT NO	PROJECT NO	TASK NO	WORK UNIT ACCESSION NO
11 TITLE (Include Security Classification) Development of an Automated Scanning Monochromator for Sensitivity Calibration of the MUSTANG Instrument (UNCLASSIFIED)					
12 PERSONAL AUTHOR(S) Thane D. Rivers					
13a TYPE OF REPORT Master's Thesis		13b TIME COVERED FROM _____ TO _____		14 DATE OF REPORT (Year, Month, Day) June 1992	15 PAGE COUNT 57
16 SUPPLEMENTARY NOTATION The views expressed in this thesis are those of the author and do not reflect the official policy of the Dept. of Defense or the US Government.					
17 COSATI CODES			18 SUBJECT TERMS (Continue on reverse if necessary and identify by block number)		
FIELD	GROUP	SUB-GROUP	Monochromator, MUSTANG, LabVIEW		
19 ABSTRACT (Continue on reverse if necessary and identify by block number) An Automated Scanning Monochromator was developed using: an Acton Research Corporation (ARC) Monochromator, Ealing Photomultiplier Tube and a Macintosh PC in conjunction with LabVIEW software. The LabVIEW Virtual Instrument written to operate the ARC Monochromator is a mouse driven user friendly program developed specifically for automated spectral data measurements. Resolution and sensitivity of the Automated Scanning Monochromator System have been determined experimentally. The Automated Monochromator was then used for spectral measurements of a Platinum Lamp. Additionally, the reflectivity curve for a BaSO ₄ coated screen has been measured. Reflectivity measurements indicate a large discrepancy with expected results. Further analysis of the					
20 DISTRIBUTION / AVAILABILITY OF ABSTRACT <input checked="" type="checkbox"/> UNCLASSIFIED//UNLIMITED <input type="checkbox"/> SAME AS RPT <input type="checkbox"/> DTIC USERS			21 ABSTRACT SECURITY CLASSIFICATION UNCLASSIFIED		
22a NAME OF RESPONSIBLE INDIVIDUAL Cleary, David D.		22b TELEPHONE (Include Area Code) (408) 646-2828		22c OFFICE SYMBOL Code39	

UNCLASSIFIED

SECURITY CLASSIFICATION OF THIS PAGE

reflectivity experiment is required for conclusive results.

Development of an Automated Scanning
 Monochromator for Sensitivity
 Calibration of the MUSTANG Instrument

by

Thane Damian Rivers
 Lieutenant, United States Navy
 B.S., United States Naval Academy, 1986

Submitted in partial fulfillment of
 the requirements for the degree of

MASTER OF SCIENCE IN ASTRONAUTICAL ENGINEERING

from the

NAVAL POSTGRADUATE SCHOOL
 June 1992

DTIC QUALITY INSPECTED 4

Author: Thane D. Rivers
 Thane D. Rivers

Approved by: David D. Cleary
 David D. Cleary, Thesis Advisor

Scott Davis
 Scott Davis, Second Reader

Daniel J. Collins
 Daniel J. Collins, Chairman

Aeronautics and Astronautics Department

Accession For	
NTIS CRA&I	<input checked="" type="checkbox"/>
DTIC TAB	<input type="checkbox"/>
Unannounced	<input type="checkbox"/>
Justification	
By	
Distribution /	
Availability Codes	
Dist	Avail and/or Special
A-1	

ABSTRACT

An Automated Scanning Monochromator was developed using an Acton Research Corporation (ARC) monochromator, Ealing photomultiplier tube and a Macintosh PC, in conjunction with LabVIEW software. The LabVIEW Virtual Instrument written to operate the ARC monochromator is a mouse-driven user-friendly program developed specifically for automated spectral data measurements.

Resolution and sensitivity of the Automated Scanning Monochromator system have been determined experimentally. The Automated Monochromator was then used for spectral measurements of a platinum lamp. Additionally, the reflectivity curve for a BaSO₄ coated screen has been measured. Reflectivity measurements indicate a large discrepancy with expected results. Further analysis of the reflectivity experiment is required for conclusive results.

TABLE OF CONTENTS

I.	INTRODUCTION	1
A.	THESIS OBJECTIVES	1
B.	THESIS OUTLINE	2
II.	EXPERIMENT BACKGROUND	3
A.	MUSTANG EXPERIMENT	3
1.	MUSTANG Instrument	3
2.	Wavelength Calibration	4
3.	Sensitivity Calibration	5
4.	Screen Preparation	5
III.	SOFTWARE/HARDWARE COMPONENTS	7
A.	HARDWARE	7
1.	ARC Spectrometer	7
a.	Scanning Mechanism	7
2.	Ealing Photomultiplier	8
a.	Photodetector Module	8
b.	Photomultiplier Power Supply	9
3.	NB-MIO-16	10
B.	MACINTOSH IIx	11
C.	LabVIEW 2.1.1	12
1.	Software Package	12
a.	Front Panel	12
b.	Block Diagram	12

2.	ARC Main	13
a.	ARC Position	18
b.	Angstroms Goto	19
c.	Increment ARC	20
d.	Read Analog Data	21
IV.	MONOCHROMATOR EXPERIMENTS	23
A.	MONOCHROMATOR RESOLUTION.....	23
B.	REFLECTIVITY MEASUREMENTS.....	24
1.	FEL Lamp.....	25
2.	Deuterium Lamp.....	29
C.	ERROR ANALYSIS.....	31
D.	PLATINUM LAMP.....	33
E.	INSTRUMENTAL SENSITIVITY.....	37
V.	CONCLUSION.....	40
	APPENDIX A: OPERATING INSTRUCTIONS	41
	LIST OF REFERENCES.....	48
	INITIAL DISTRIBUTION LIST.....	50

I. INTRODUCTION

High frequency (HF) electromagnetic waves used in a variety of military systems are reflected and refracted by the earth's ionosphere. Accurate ionospheric mapping will enhance the ability of system users to optimize and to tailor HF transmission. Measurement of the electron density in the Earth's ionosphere has been listed as the number five priority by the Joint Chiefs of Staff Memorandum MJCS 154-86 [Ref. 1]. Currently electron densities are measured with ground based ionosondes. This method is accurate but spatially limited in its ability to collect data. Ideally, space-based observation platforms will make passive measurements of the earth's airglow spectra. Global, real time electron density maps would then be forecast based on that spectrographic data.

The Middle Ultraviolet Spectrograph (MUSTANG) is an instrument developed by scientists at the Naval Postgraduate School to measure the Earth's airglow spectra. Development of forecasting methods are currently underway based on the information gained during two separate rocket launches of the MUSTANG instrument.

A. THESIS OBJECTIVES

The focus of this thesis is to develop an automated scanning monochromator to be used in MUSTANG calibration. The scanning Monochromator has been used to measure the reflectivity of a diffuse

reflecting screen. This screen is subsequently used during the MUSTANG instrument calibration. It is hoped that analysis of The screen will improve the sensitivity calibration of the MUSTANG instrument as described in the next chapter.

B. THESIS OUTLINE

This thesis is divided into five chapters. Chapter II describes the MUSTANG experimental goals and the instrument calibration techniques. A persistent shortcoming of the MUSTANG experiment has been the uncertainty in its' sensitivity calibration. An automated scanning monochromator was developed to analyze the BaSO₄ screen used in the sensitivity calibration process. Chapter III is a description of the hardware component assembly and software development leading to the ARC Automated Scanning Monochromator. Experiments with the Automated Scanning Monochromator are the focus of Chapter IV. These experiments are: measurement of the instrument resolution, reflective property measurements on the BaSO₄ screen and sensitivity calibration for the instrument. The thesis conclusion is Chapter V.

II. EXPERIMENT BACKGROUND

A. MUSTANG EXPERIMENT

To date the MUSTANG has made two flights from White Sands Missile Test Range. The instrument was launched from a NASA Terrier Blank Brant sounding rocket. The MUSTANG is designed to measure emissions from NO, N₂ and N⁺ in the D and E regions of the ionosphere. These atmospheric constituents are mainly responsible for the ion population in this 100 to 200 km altitude range. However, the photochemical production process is very complicated, with numerous free parameters. Models do exist to estimate the ion production levels. By establishing some constituent densities the models can be improved and validated. The consummation of the MUSTANG project will be the generation of global electron density maps used for optimization of HF electromagnetic wave transmission.

1. MUSTANG Instrument

The MUSTANG instrument is a 1/8 meter Ebert-Fastie spectrograph with an off-axis telescope. The entrance slit is 5 mm high by 140 microns wide. The resulting field of view is 2.3 degrees by .006 degrees. The diffraction grating is ruled at 1200 lines per millimeter. The component arrangement gives wavelength coverage from 1800 to 3400 Angstroms, as previously mentioned. The photodetector is an ITT F4145 image intensifier, fiber optically coupled to a Hamamatsu S2300-512Q 512 element photodiode array. [Ref. 2:p. 18] The output of the

photodiode is an analog voltage linearly proportional to the incident intensity. The grating focuses a particular incident wavelength on a specific photodetector element (pixel).

2. Wavelength Calibration

Correlation of the incident wavelength to pixel response relationship is the instrument wavelength scale calibration. The wavelength calibration of the 512 pixel detector has been accomplished using a platinum lamp. The platinum spectrum has well-known lines [Ref. 3:p. 463] as shown in Figure 2-1. The 23 lines identified in the

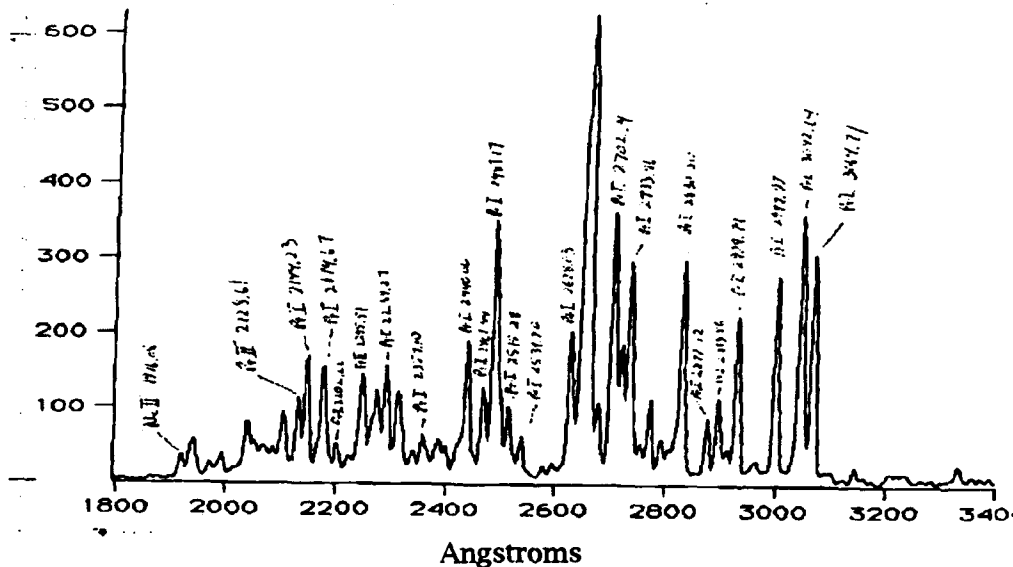

Figure 2-1 Spectral Lines of a Platinum Source

figure are plotted against photodiode pixel number. (Figure 2-2) The result is the wavelength calibration for the instrument. The equation obtained from a least squares linear approximation of Figure 2-2 is:

$$\text{Angstroms} = 3.13376 * \text{pixel} + 1797.98$$

Therefore each pixel spans roughly a 3.13376 Angstrom range beginning around 1800 Angstroms and continuing to about 3400 Angstroms. The calibration is extremely sensitive to internal component alignment. The

instrument is calibrated pre-flight as well as post-flight specifically to check for any alignment disturbance encountered during the flight and recovery phases of the instrument.

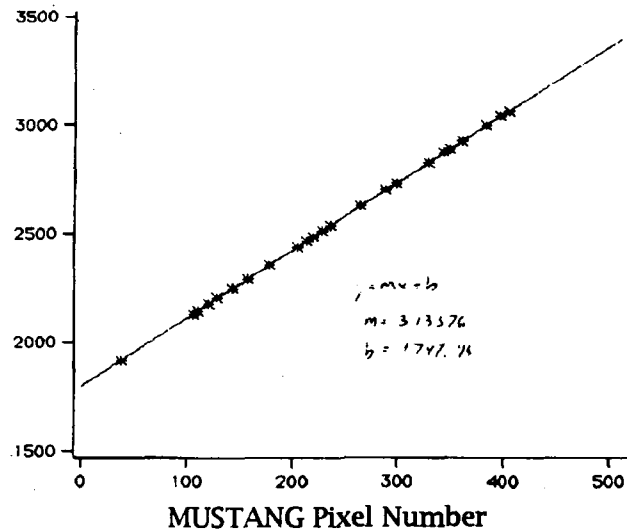

Figure 2-2 Linear Relationship of Wavelength to Pixel

3. Sensitivity Calibration

The sensitivity calibration is the relationship between the incident photon flux and the detector analog current output. A deuterium lamp was used as the light source for this calibration. The light source illuminates a barium sulfate (BaSO_4) screen. The photons are reflected from the screen and enter the aperture of the MUSTANG instrument. The screen is necessary to simulate the nature of the Earth's atmosphere as an extended, scattering source. Simply shining the lamp into the aperture would more closely simulate a point source. Ideally, the extended source provides uniform irradiance across the entrance aperture, as it happens in the actual experiment.

4. Screen Preparation

The reflecting screen coating is White Reflectance Standard manufactured by the Eastman Kodak Company. Grum and Luckey

suggest the use of this material in their paper *Optical Sphere Paint and a working Standard of Reflectance* [Ref. 4:p. 2293]. Its characteristics are: (1) a high standard of reflectance ($\approx .99$), and (2) little deterioration with time. Additionally their investigation has shown that the BaSO₄ coating is stable even under a high flux of ultraviolet exposure. This is the exact spectral region of interest for the MUSTANG experiment. Additionally, the manufacturer provides a laboratory sprayer making the application very simple. The manufacturer provides reflectivity data for the BaSO₄ coating, and the data is given in Table 2-1. The reflectivity data given here has been used for the sensitivity calibration of the MUSTANG instrument. The uncertainty in this type of sensitivity measurement is typically on the order of 20% [Ref. 5:p. 92].

<u>λ Angstroms</u>	<u>Reflectivity</u>
2500	.950
3500	.979
4000	.987
5000	.991
7000	.992

**Table 2-1 White Reflectance
Standard Reflectivity Values**

A goal of this thesis is to measure the reflectivity of the BaSO₄ screen used for the MUSTANG sensitivity calibration. The correlation of this experiment and the published Kodak reflectivity data will determine if further sensitivity calibration is required. If the experimental findings differ from the published reflectivity data, it will be necessary to adjust the MUSTANG Spectroscopic data accordingly.

III. SOFTWARE/HARDWARE COMPONENTS

A. HARDWARE

1. ARC Spectrometer

The Acton Research Corporation (ARC) Model VM-503 is a nominal .3 meter scanning monochromator, with a modified Czerny-Turner optical system. The optical surfaces in the instrument are supplied with Al and MgF₂ coatings optimized for the ultraviolet spectral region. Micrometer-controlled entrance and exit slits are incorporated into the housing and are selected in 10 micron wide increments.

a. *Scanning Mechanism*

A sine drive provides a linear wavelength scan via rotation of a precision lead screw. A Model 747 Monochromator Scan Module works in conjunction with the Model 747 stepping motor providing power and drive commands to the lead screw. A knob on the housing side panel is provided to manually scan the spectrometer when power is secured to the scanning motor. One revolution of the stepping motor corresponds to a wavelength shift of 26.66 Angstroms for the grating installed (1200 rulings/mm). A five digit readout located on the instrument housing indicates the wavelength reading in Angstroms.

The Model 747 Monochromator Scan Module receives command input through a three wire RS-232C connection. The commands are stored in EPROM within the Monochromator Scan Module. Information on command definitions and parameters are found in

reference 6. The spectrometer comes equipped with a Sharp PC-7100, referred to as the Model 747-PC pocket computer. This is a Sharp calculator with a special chip installed. The chip runs an algorithm that dedicates the Model 747-PC as a command device for the ARC Monochromator. Initially the 747-PC was the only input device for spectrometer scan control. In the lab environment, LabVIEW 2.1.1 VI *ARC Main*, run on a Mac, completely replaces the Model 747-PC.

When using the Mac an adapter must be used in line with the RS-232 connection. Both the Mac and the Monochromator Scan Module are configured as Data Control Equipment (DCE). A DCE device transmits on pin 3 and receives on pin 2. Normally, DCE equipment is configured to communicate with Data Terminal Equipment (DTE) [Ref. 7:p. 723]. It is possible to rewire the ARC Monochromator Scan Module; however this would inhibit further use of the Model 747-PC as a control device. As such, an adapter was made for use in conjunction with the Mac. The adaptor simply cross-connects pin 2 and pin 3 so that the ARC Monochromator Scan Module will look like DTE to the MAC.

The ARC spectrometer is driven with the Mac so that the *ARC Main* software can correlate wavelength with detector voltage for spectrum analysis and data recording.

2. Ealing Photomultiplier

a. Photodetector Module

The photodetector module consists of a 28.6mm outside diameter head on tube, dynode resistor chain, with electrical and magnetic screening, preamplifier, and a provision for filters and

diffusers. The tube body is fitted with two, 2 meter leads; one for high voltage power supply and one for the ± 15 volt preamplifier supply. The photomultiplier is an 11 stage tube with a linear operating range for voltages of -600 to -1800 volts. This detector is equipped with an optical quartz window for optimal response in the ultraviolet region. The spectral response for the S11 tube is shown in Figure 3-1 [Ref. 8:p. 164].

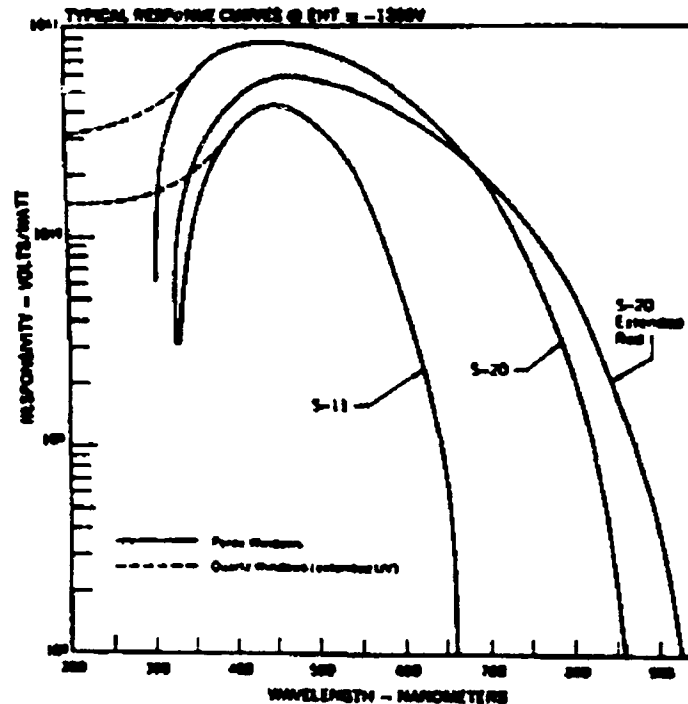

Figure 3-1 Spectral Response of Photomultiplier

b. Photomultiplier Power Supply

The photomultiplier power supply has two inputs on the rear of the box which accept the leads from the photomultiplier housing. The unit provides ± 15 volts DC for the detector preamplifier. It also provides a 1 milliamp variable regulated -1500 volt DC supply. The voltage level is adjustable by coarse and fine control knobs. An analog

meter displays the power supply voltage. Additionally there is a BNC connector on the front panel for analog voltage output. The output voltage is conditioned and scaled to the relative output from the photomultiplier. This output is wired to an analog input channel of the NB-MIO-16 board for use with LabVIEW VI *ARC Main*.

3. NB-MIO-16

The NB-MIO-16 is a multifunction analog, digital, and timing input/output board for the Macintosh II. The *ARC Main* program uses only the analog to digital (A/D) conversion function of this board.

The NB-MIO-16 contains a 12 bit A/D converter with 16 analog inputs. The NB-MIO-16 board can be configured in a variety of input modes that are covered in reference 9 page 2-3. Only the settings required and used by *ARC Main* are covered in this section. The input mode is ground-referenced and single-ended. All input signals are converted based on the channel voltage referenced to a common ground point tied to the analog input ground on the board. The input range is unipolar with a dynamic range of 0 to 10 volts. The gain (software selected) is set at 1 which, according to reference 10 page 2-9, gives a digitized precision of 2.44mV. This precision corresponds to the least significant bit of the 12 bit A/D conversion. A pinout map for the NB-MIO-16 is shown in Figure 3-2. Ground and channel 0 pins are wired to the coaxial output from the photomultiplier tube. Maximum analog input voltages for the NB-MIO-16 board are ± 20 volts power off and ± 35 volts with power on. Reference 6 page 2-15 also makes note that the input leads should not be longer than 15 feet.

AI GND	1	2	AI GND
ACH0	3	4	ACH8
ACH1	5	6	ACH9
ACH2	7	8	ACH10
ACH3	9	10	ACH11
ACH4	11	12	ACH12
ACH5	13	14	ACH13
ACH6	15	16	ACH14
ACH7	17	18	ACH15
AI SENSE	19	20	DAC0 OUT
DAC1 OUT	21	22	EXTREF
AO GND	23	24	DIG GND
ADIO0	25	26	BDIO0
ADIO1	27	28	BDIO1
ADIO2	29	30	BDIO2
ADIO3	31	32	BDIO3
DIG GND	33	34	+5 V _{dig}
+5 V _{dig}	35	36	SCANCLK
EXTSTROBE*	37	38	EXTTRIG*
EXTGATE	39	40	EXTCONV*
SOURCE1	41	42	GATE1
OUT1	43	44	SOURCE2
GATE2	45	46	OUT2
SOURCE3	47	48	GATES
OUT3	49	50	FOUT

Figure 3-2 Pinout of NB-MIO-16 Board Connections

B. MACINTOSH IIx

The Macintosh IIx personal computer was selected because of its open architecture. This refers to the Macintosh (Mac) NuBus configuration allowing for connection of up to 6 peripheral devices. These devices include video cards, modems, and special application boards. This makes the Mac ideal for operation with the LabVIEW software package and the National Instruments boards. The peripheral used for this application is a National Instruments NB-MIO-16 multifunction analog, digital, and timing input/output board. The Mac used for the experiment is equipped with a 16MHz clock, 4MB RAM and a 40MB hard drive.

C. LabVIEW 2.1.1

1. Software Package

LabVIEW is an icon-oriented programming language. Each icon is a virtual instrument (VI) that performs a specified function. All VI names in this document will be denoted in *italics*. An example of one LabVIEW VI is a multimeter emulator. It has virtual control knobs to select voltage, resistance, and current functions. Other virtual knobs control scale settings, analog and digital data indicators, etc. Each VI is composed of two parts: a front panel and a block diagram.

a. *Front Panel*

The front panel is the operator-software interface. Input devices are controls. LabVIEW recognizes various numeric, Boolean and string inputs. Outputs from devices are displayed on the front panel with numeric, Boolean and string indicators. The output may also be displayed in many other forms including graphs, meters, data arrays, data clusters, etc. The programmer chooses the arrangement, display format, precision, representation and screen colors for all of the inputs and outputs. For instance, the front panel could be arranged in function and presentation to look like a Fluke multimeter.

b. *Block Diagram*

The block diagram defines the interconnections of all of the front panel inputs and outputs. Additionally, operations are performed on the inputs within the block diagram environment. Individual inputs, outputs and VI's are virtually "wired" together such

that there is connectivity between elements of a particular VI. Through this virtual "wiring" process the programmer creates and tailors new VI's.

By creating a VI hierarchy and appropriately grouping the VI's into nested levels the programmer creates tools that any user can easily operate without detailed knowledge of LabVIEW software. The following sections describe the operation of *ARC Main*, a program written to operate the scanning monochromator. Operating instructions are included as Appendix A.

2. ARC Main

ARC Main is the VI used to operate the ARC Spectrometer. The VI hierarchy for *ARC Main* is shown in Figure 3-3. It requires initial input of spectrometer wavelength and scan wavelength information. The program then scans through the specified wavelength range and records the spectrum. The spectrum is displayed in graphic format as shown on the front panel of *ARC Main* in Figure 3-4. This is a mercury spectrum from 4000-6000 Angstroms, scanned in 2.5 Angstrom increments.

The digital controls near the screen center are data inputs. The EXECUTE SCAN push button calls and executes the VI *ARC Position*. This VI initiates action as described in the following sections. The SAVE push button initiates a VI *SAVE TO DISK*. This VI was written by J. H. Quint [Ref. 11:p. 100]. It saves data in an ASCII format that can be read by most word processor programs. The VI has been renamed and stored in the ARC SPECTROMETER directory so that data is stored in the ARC DATA FILES.

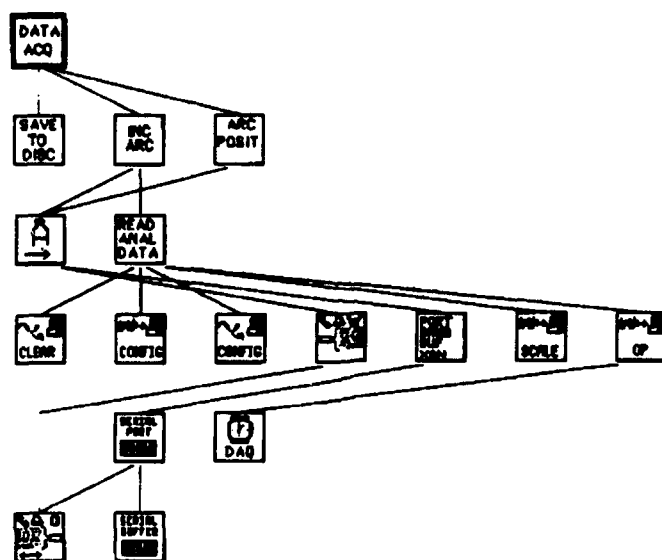

Figure 3-3 VI Hierarchy within *ARC Main*

The block diagram for *ARC Main* is depicted in Figure 3-5. The function of the entire diagram are encompassed by a software WHILE loop that continuously recycles through the program. Initially, when the iteration of the counter of the WHILE loop is zero, the value of the digital control INSTRUMENT WINDOW will be the input for VI's *ARC Position* and *Increment ARC*. At this point of the program the digital controller is the surface window on the VI front panel. The controller is a read-write device allowing for user input of the actual monochromator wavelength setting. All subsequent iterations of the WHILE loop correspond to counter values greater than zero and the value of the output displayed by the digital indicator INSTRUMENT WINDOW becomes the surface window on the front panel of *ARC Main*. The value displayed by the indicator INSTRUMENT WINDOW is a read-only device and the source of input for further VI execution. The indicator on the front panel will mimic the monochromator wavelength setting.

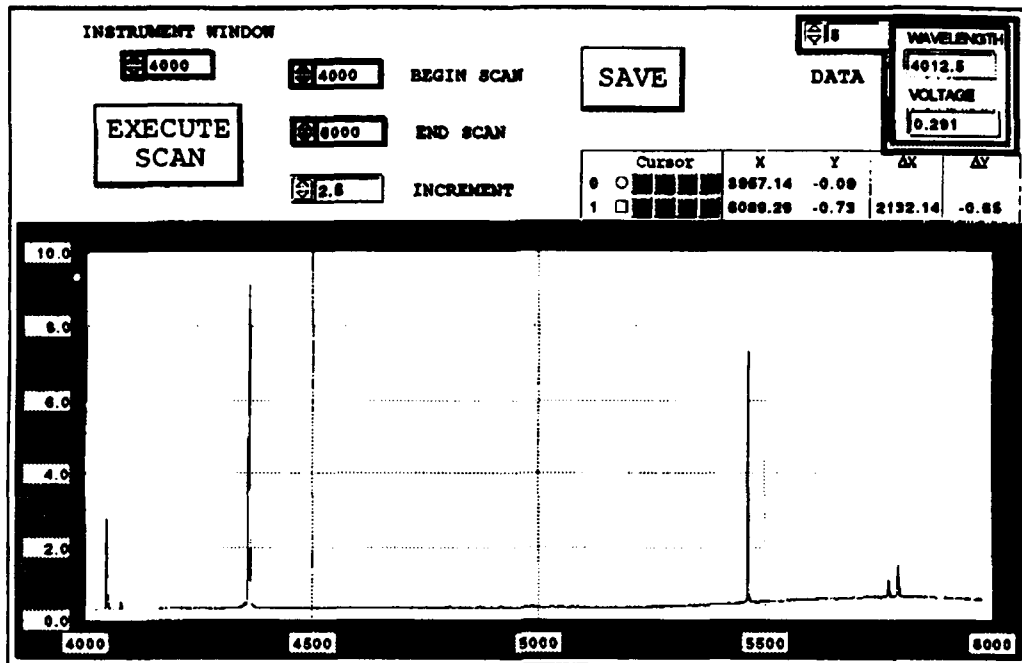

Figure 3-4 *ARC Main Front Panel*

Begin Scan, End Scan and Increment are all digital controllers for input of the scan values. A double click of the mouse will open the controller for input as described above.

The boxes along the edge of the WHILE loop with downward pointing arrows are shift registers. The shift register passes a single parameter from one iteration of the WHILE loop to the next iteration. This value may be updated during the execution of a single iteration or may be updated during a series of iterations.

Push button controls are indicated in the upper left hand corner of the block diagram (Figure 3-5). All push buttons are of the spring latch type. They are activated by a single click of the mouse and remain active until the program calls for the corresponding input. The

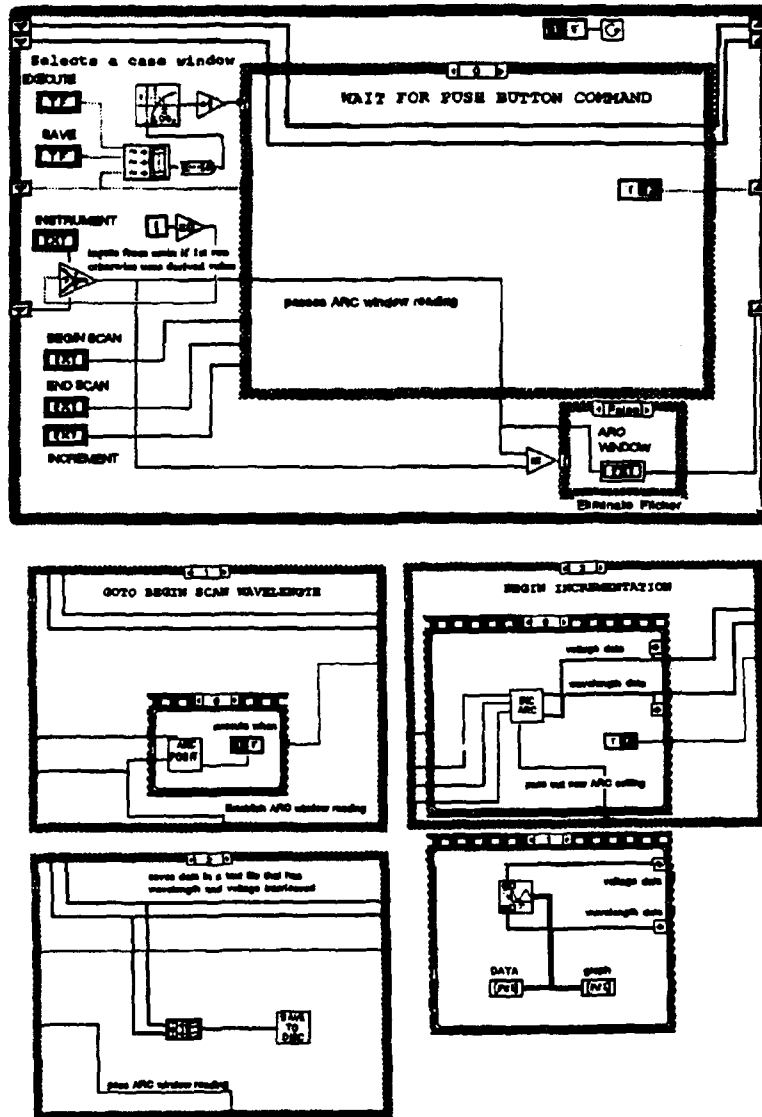

Figure 3-5 ARC Main Block Diagram

latch is then released, returning the corresponding Boolean input to its default (false) value.

Inside the WHILE loop is another box, labeled 0. This is a case structure. In this instance there are four cases to the structure (0,1,2,3), all denoted in Figure 3-5. The push buttons Execute, Save and the shift register function in concert to select and to execute one of these cases,

as described in the following discussion. The three Boolean values (two push buttons and one shift register) are concatenated by the *Build Array* function. The *Build Array* output is passed to *Boolean Array to Number*. The resulting decimal number is then converted by the *Log base 2* and *Increment* functions. This allows for a single button to select a case structure box as indicated by Table 3-1. This selection technique is outlined on page 6-3 of reference 10. Note that EXECUTE SCAN invokes Case 1. Within of Case 1 there is a sequence structure. A sequence structure automatically executes in frame number ascending order. For instance within Case 1 there are Frames 0 and 1. Frame 0 executes *ARC Position*. Frame 1 (not shown) outputs a Boolean TRUE to the shift register. The Boolean TRUE selects Case 3. Within Case 3, Frame 0 executes the VI Increment ARC. Frame 1 then sequentially logs voltage and wavelength data.

BUTTON	ARRAY	DECIMAL #	LOG B2	CASE
NONE	000	0	$-\infty$	0
EXECUTE SCAN	001	1	0	1
SAVE	010	2	1	2
Case 1	100	4	2	3

Table 3-1 Push button case selection table

The two shift registers at the top of the diagram are data buses for wavelengths and voltages generated by *Increment ARC* and are more thoroughly covered in section C.2.c. The shift register in the lower half is used to eliminate flickering of the INSTRUMENT WINDOW value on the

front panel. Without this, the value is updated every iteration of the WHILE loop, causing an annoying flicker on the terminal screen. Currently the display is only updated when a new value is generated.

a. *ARC Position*

ARC Position moves the monochromator grating from the current wavelength, indicated by INSTRUMENT WINDOW, to the setting of BEGIN SCAN. The block diagram for *ARC Position* is depicted in Figure 3-6 (note that the False case is not shown).

Frame 0 simply computes the difference between the current monochromator wavelength and the desired starting wavelength. The difference is the input for the VI *Angstroms Goto*. The

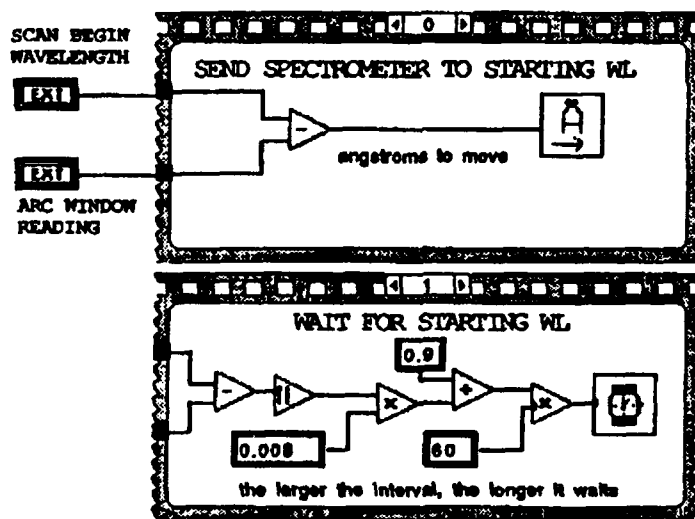

Figure 3-6 VI *ARC Position* Block Diagram

operation of this VI is discussed in the next section. Frame 1 of *ARC Position* is a pause routine, allowing the instrument to mechanically slew to the desired wavelength before initiating further software or hardware

action. The formula for the time to pause is based on the instrument's scan velocity rate and stopwatch measurements for various distances. In order to determine the time delay, a plot of time verses angstroms of slew was generated.

b. *Angstroms Goto*

The ARC Monochromator Scan Module requires a serial command string in the form of ASCII characters. The VI *Angstroms Goto* creates the ASCII string and outputs it to the Mac modem port. Originally written by D. D. Cleary of the Naval Postgraduate School, the VI *Angstroms Goto* has been modified to initialize and to operate the Mac serial port drivers.

Frame 0 accomplishes the serial port initialization according to the following parameters specified in reference 6 section II:

- 9600 BAUD
- NO PARITY
- 8 DATA BITS
- FULL DUPLEX
- BUFFER SIZE 200

Frame 1, depicted in Figure 3-7, generates the ASCII command string and transmits it to the ARC Monochromator Scan Module. The Angstroms input is corrected by constants discussed in section C.1.a. The resulting number is converted to a string and concatenated with values for lead screw acceleration, lead screw velocity, and the GO command. The complete command string is then output to the modem serial port. Control is then returned to *ARC Main* with the instrument at the wavelength requested for scan initialization.

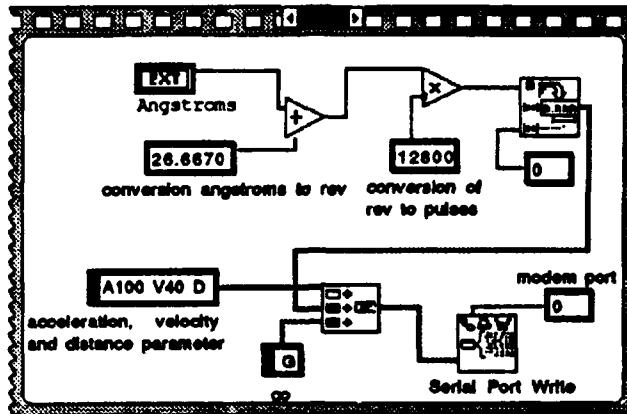

Figure 3-7 *Angstroms Goto* Block Diagram

c. *Increment ARC*

This VI is called from Case 1 of *ARC Main* after execution of *ARC Position*. This ensures that the instrument is always at the BEGIN SCAN wavelength before incrementing for readings. The VI iteratively increments the instrument and reads a voltage by way of the NB-MIO-16 board discussed in section C.3. Additionally the front panel of this VI is displayed as an overlay on the *ARC Main* front panel such that the current Instrument window reading is visible during scan execution.

The block diagram for *Increment ARC* is shown in Figure 3-8. The comparison function on the left determines the sign of the increment based on the values of the initial and final scan wavelengths. The FOR loop is initialized with the appropriate number of steps to be executed, based on the distance to travel and the incremental step for each iteration. Frame 0 of the sequence structure calls the VI *Read Analog Data* and logs the voltage. Frame 1 calls VI *Angstroms Goto*. In this application the VI increments the spectrometer and logs the wavelength. This wavelength is then updated on the front panel. Frame

3, not shown, waits for the mechanical lead screw rotation to complete before returning to frame 0 and reading the next voltage.

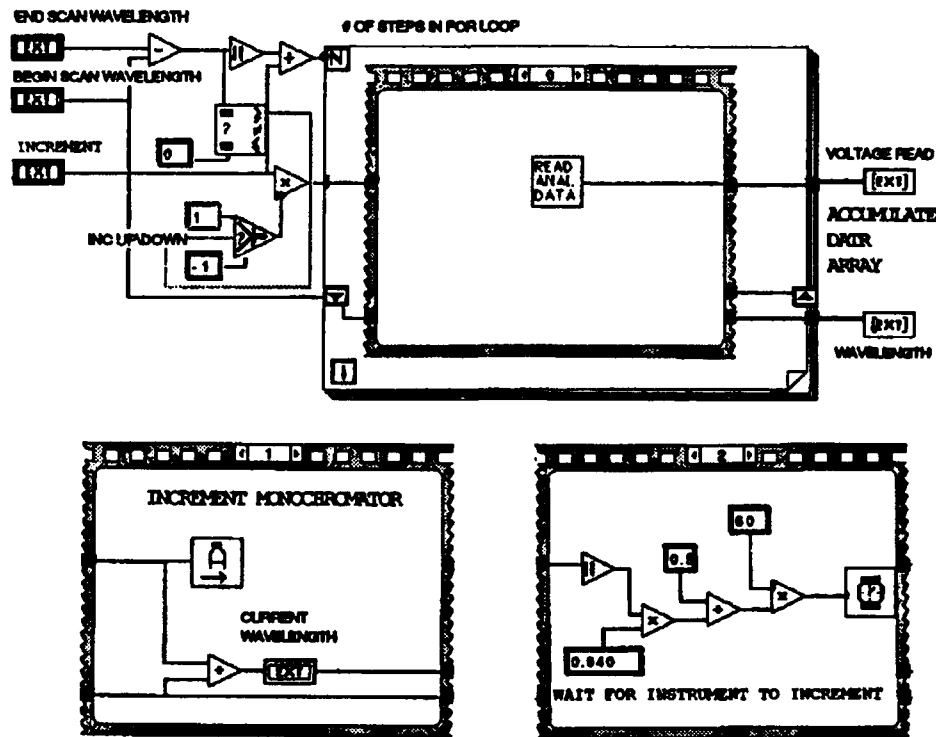

Figure 3-8 Increment ARC Block Diagram

d. Read Analog Data

When called, the VI *Read Analog Data* will acquire the binary value at channel 0 of the NB-MIO-16 A/D board. The output voltage is logged for input to the front panel of *ARC Main*.

Frame 0 (not shown) clears the NB-MIO-16 registers, and inputs the board slot number for configuration of the board. Frame 1 (not shown) calls VI's *DAQ_Config* and *AI_Config*. These VIs are part of the LabVIEW library, and information is available in reference 12. Frame 2 shown in Figure 3-9, calls *DAQ_OP* and *DAQ_Scale*, also part of the

LabVIEW library. The arrow on the left is the board slot number input from Frame 0. Other inputs are:

- Clock-2 corresponds to 100KHz clock speed
- Gain-1
- Channel-0 read from channel 0 only
- Samples-10,000 number of samples to read
- Interval-2 =2* clock resolution (10µsecs)

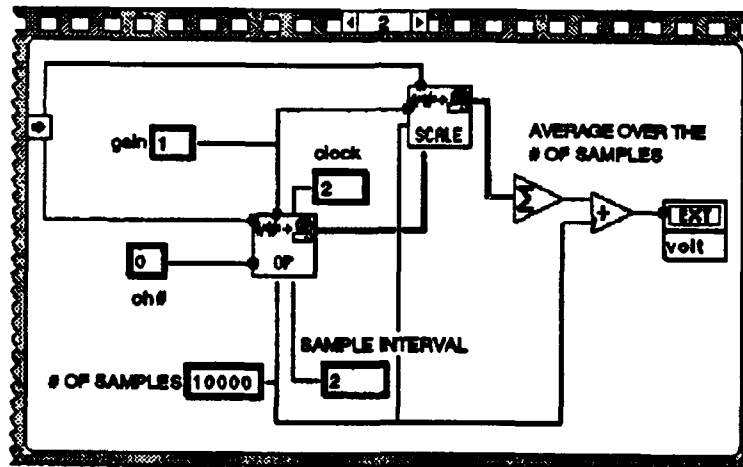

Figure 3-9 Read Analog Data Block Diagram

IV. MONOCHROMATOR EXPERIMENTS

A. MONOCHROMATOR RESOLUTION

The first experiment conducted on the monochromator was to determine its inherent resolution limit. The 4360 and 5435 Angstrom lines of a green He-Ne laser were used in the determination of the ARC Model VM-503 Scanning Monochromator's resolution. The entrance and exit micrometer controlled slits were always kept at equal widths in this determination. First the Monochromator was tuned to the 4360 Angstrom peak of the green He-Ne laser. The full width at half maximum (FWHM) of this peak was then measured at a variety of slit widths. Each increment of the micrometer scale corresponds to 10 micrometers in slit width. Table 4-1 enumerates the data results. The analog output voltage increases as the slit is opened even though the PMT power supply gain setting was constant (1.29 Kilovolts). The increase in output voltage is due to the increase in photon flux.

Slit Width		Peak	FWHM
Micrometer scale	Micrometers	Volts	Angstroms
2.0	20	0.28	2.0
2.5	25	0.29	2.0
3.0	30	0.34	2.0
4.0	40	0.41	2.2
5.0	50	0.49	2.4
6.0	60	0.55	2.5
7.0	70	0.60	2.5
8.0	80	0.68	2.8
9.0	90	0.75	3.4

Table 4-1 FWHM for the 4360 Angstrom line of He-Ne laser

As the slits are widened more photons enter the instrument and strike the detector. The same procedure was used with the 5435 Angstrom line; these data are given in Table 4-2. In both cases the FWHM limit converged to 2 Angstroms. There is a linear relationship between the FWHM and slit width, provided that the latter is substantially wider than the diffraction limit established by the Rayleigh criterion.. As the slit width is doubled so is the FWHM. The 4360 Angstrom line produces less voltage than the 5435 Angstrom line at the same slit width. This is a result of the He-Ne laser output being much more intense at 5435 Angstroms. Again, the voltage output is directly related to the number of photons incident on the detector.

Slit Width		Peak	FWHM
Micrometer scale	Micrometers	Volts	Angstroms
2.5	25	0.8	2.0
5.0	50	3.0	2.0
6.0	60	4.0	2.2
7.0	70	4.7	2.3
8.0	80	5.6	2.7
9.0	90	6.4	2.9
10.0	100	8.0	3.5
15.0	150	9.8	5.1
20.0	200	10.0	7.5

Table 4-2 FWHM for the 5435 Angstrom line of He-Ne laser

B. REFLECTIVITY MEASUREMENTS

The next experiment was to determine the reflectivity of the screen coated with the White Reflectance Standard. This screen is used to create an extended light source for the calibration of the MUSTANG flight instrument. As discussed in Chapter II, a deuterium lamp and an FEL lamp are used to calibrate the MUSTANG instrument. Both of these sources have intensity and spectral data provided by their respective

manufacturers. One utility of the automated scanning monochromator is to determine if this information can be used directly in the analysis of MUSTANG flight data. If the manufacturer's data is not found to be accurate, then a re-evaluation of MUSTANG spectral calibration data would be in order.

A He-Ne laser was used to ensure that the source lamp was in the field of view (FOV) of the monochromator, using a reverse light path technique. The PMT was unbolted from the chassis of the monochromator. The He-Ne laser was then aligned on the axis of the instrument, shining into the exit slit. With the scanning grating set to 5435 Angstroms, the laser light passed through the monochromator, leaving the chassis at the entrance slit. The source lamp was then placed directly in the laser beam at a distance of 7.54 meters. This assured that light leaving the source would enter the PMT detector elements. The PMT was then reinstalled and the power supply set at 1.29 kilovolts.

1. FEL Lamp

An FEL lamp is a tungsten filament light bulb used as an intensity standard. It is a black body source with a peak radiance at 9000 Angstroms. Due to the high cost of a deuterium lamp the FEL lamp was first used to determine the reflective properties of the screen. With this black body continuum source, the resolution of the scanning instrument does not significantly affect the measured spectrum. The entrance and exit slits were set at 80 microns. This allowed an acceptable number of photons to strike the detector element. The monochromator grating was tuned to 5000 Angstroms, and the PMT power supply set at a gain level such that the maximum voltage output would be less than 10 volts. The

monochromator then conducted a scan over a range of 3000 to 8000 Angstroms at an interval of 5 Angstroms. The result of this scan is Figure 4-1.

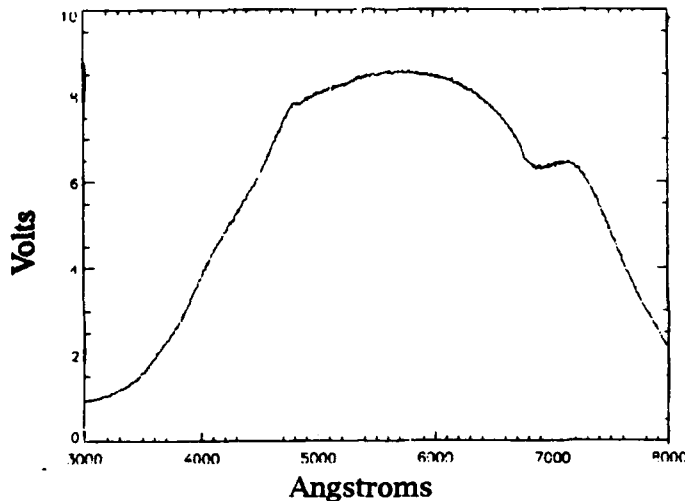

Figure 4-1 FEL Direct Spectrum

Next the monochromator was arranged to conduct a scan of the reflection of the FEL lamp from the reflectance standard. This arrangement is depicted in Figure 4-2. The screen is placed normal to the source. The angle of the monochromator relative to the screen was assumed to be inconsequential, since the screen approximates an ideal Lambertian surface. The distance from the source to the screen was 1.99 meters. The result of this scan is given in Figure 4-3. Note the large variation from one spectral sample to the next. This is thought to be the result of a much lower photon flux entering the monochromator. The lower level of photon flux results in a larger fluctuation of the PMT output. The PMT detector fluctuation is inversely proportional to the square root of the number of photons. Therefore, fewer photons result in more random output voltages. Increasing the number of samples

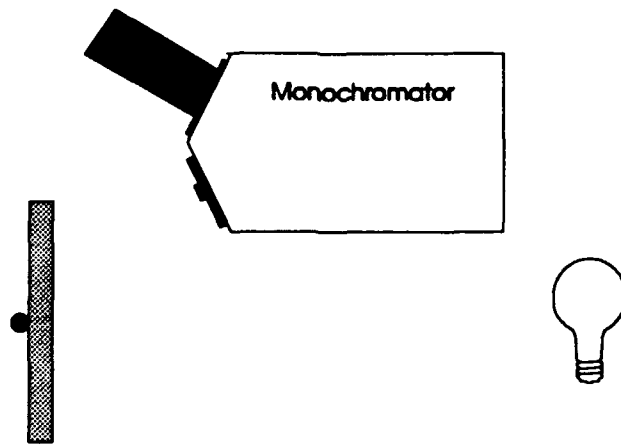
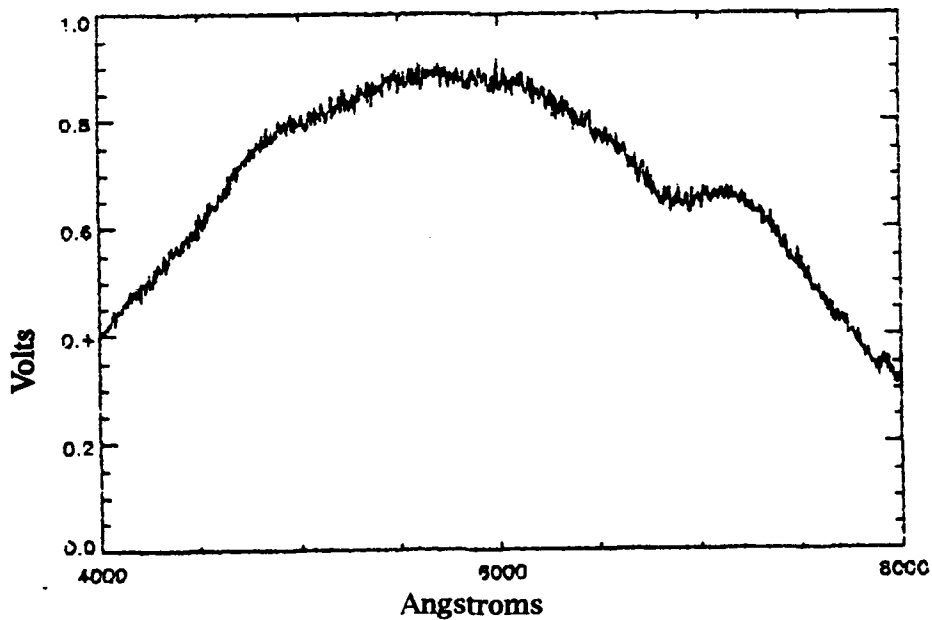

Figure 4-2 Experimental Set Up

averaged by the software algorithm from 10,000 to 100,000 smoothed out this curve. The 100,000 sample scan is Figure 4-4. The result is much smoother and more closely resembles the spectrum taken directly from the FEL lamp.



**Figure 4-3 FEL Reflected Spectrum
at 10,000 Samples per Increment**

According to the Eastman Kodak company the White Reflectance Standard is 99.1% reflective at 5000 Angstroms. To validate the published reflectivity values, the reflecting screen voltages have been normalized with the direct voltages to be 99.1% at 5000 Angstroms. A plot was then generated by dividing the normalized screen voltages into the direct looking voltages. This ratio is plotted in Figure 4-5. Notice that the value of the curve is roughly unity in the range of 5000 to 6000 Angstroms, as expected.

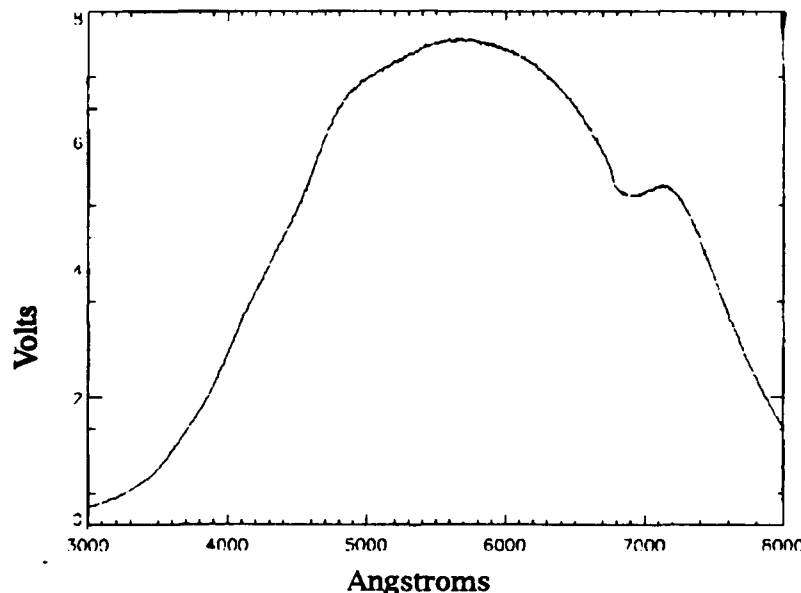

**Figure 4-4 FEL Reflected Spectrum
at 100,000 Samples per Increment**

However, according to the reflectivity data for the White Reflectance Standard the values should be approximately 96% at 3000 Angstroms. The graph of Figure 4-5 shows a reflectance of 36% at 3000 Angstroms. This is significantly lower than expected. In an attempt to confirm or to explain the low measured values, the screen reflectivity was measured again using a different light source.

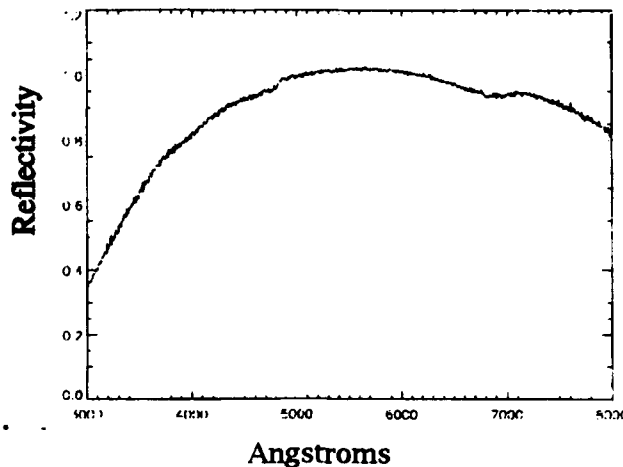

**Figure 4-5 Reflectivity of the Screen
as Measured With a FEL Lamp**

2. Deuterium Lamp

If the screen was indeed 36% reflective at 3000 Angstroms, then this should be confirmed with a deuterium lamp as well. In fact the reflectivity curves from the two lamps should have the same slope in the overlapping wavelength range (3000-5000 Angstroms).

A deuterium lamp was also used to examine the screen at shorter wavelengths. The deuterium lamp's radiance peaks at about 2600 Angstroms. The experimental setup is identical to that used in the FEL lamp spectral scans. A laser was used to align the source and the PMT gain adjusted for voltage readings not to exceed 10 volts. The direct scan is given as Figure 4-6 and the reflected scan is given as Figure 4-7. In this case the voltage level was higher for the reflecting scan. This is simply due to increasing the gain on the PMT power supply.

For comparison with the FEL reflectivity curve the deuterium reflectivity curve has been normalized to 36% at 3000 Angstroms. This curve is plotted along with the FEL reflectivity curve in Figure 4-8. Figure 4-8 clearly shows that the two reflectivity measurements do not agree.

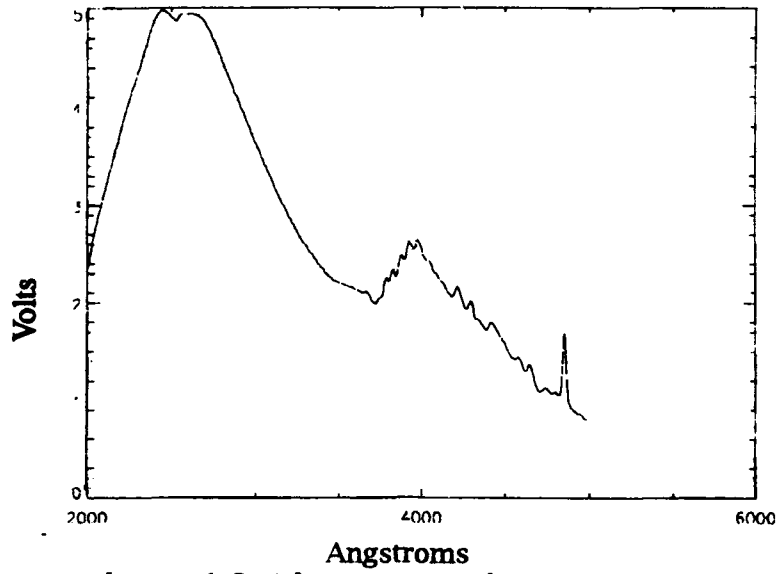

Figure 4-6 Direct Deuterium Spectrum

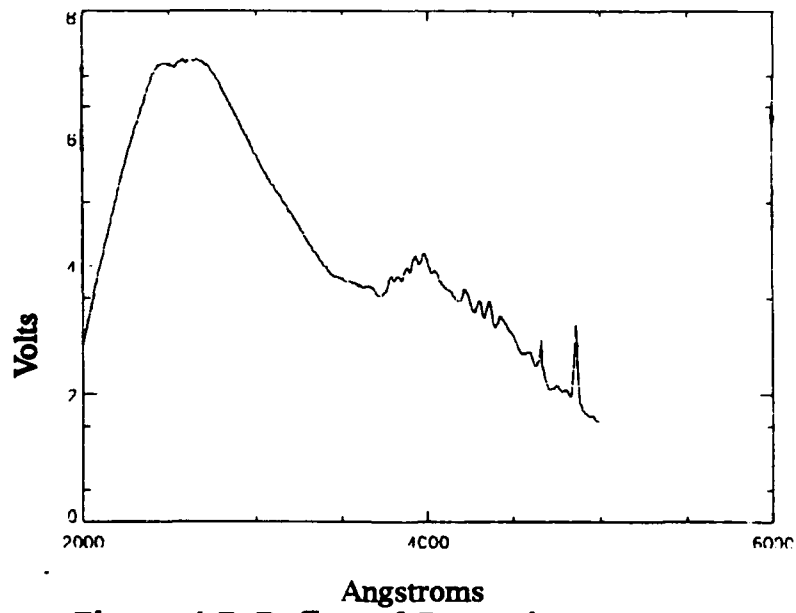
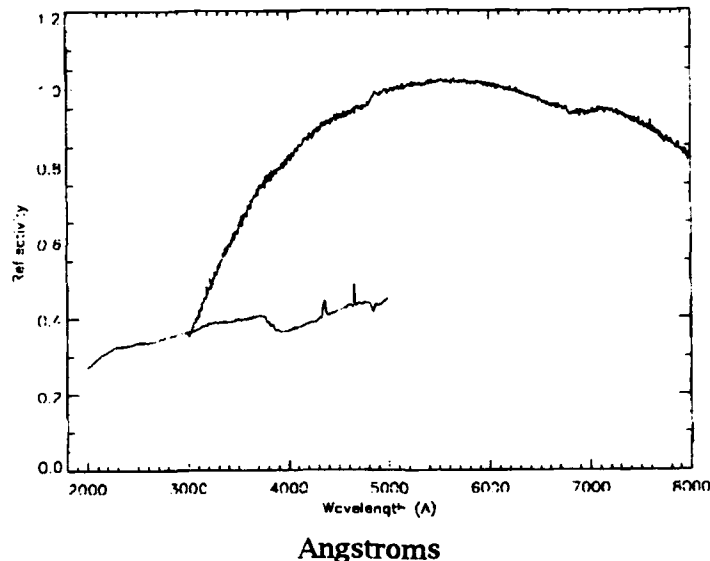

Figure 4-7 Reflected Deuterium Spectrum



Angstroms
**Figure 4-8 Combined Reflectivity
 Curves from FEL and Deuterium Lamps**

C. ERROR ANALYSIS

Reflectivity measurements on the BaSO₄ screen are inconclusive. Clearly, neither the ordinates or the slopes of the two curves correspond. What is not clear is why the reflectivity is significantly lower than the expected level. One possibility is that the reflectivity has deteriorated over time. Exposure to strong ultraviolet sources, accumulation of dust, and other environmental factors, will affect the reflective properties of the screen coating. Possibly the reflectivity is debilitated in one spectral range more than in another. However, the expected transition from one spectral region to another should be smooth, and reflectivity measurements in the overlap range (3000 - 5000 Angstroms) between the FEL and deuterium lamps should coincide.

A variable in the experimental setup is the nature of the emission from the source. In the direct scans, the light that entered the monochromator originated from a point source. Perhaps all components

of the lamp are not in the FOV of the instrument. The instrument could be scanning only part of the internal lamp elements or the glow from the quartz globe. Both lamps have a complicated internal construction. The effect of not looking directly at the tungsten element or of looking at the internal ceramic supporting structure is not known.

Another possibility is that the incident light may not be filling the internal optics of the instrument. Again, the implications of not filling the optics are not fully understood, but they could be a variable in the analysis. When scanning the reflecting screen the source is extended, and the entrance slit is completely filled with flux from the source. Possibly, the monochromator is sensitive to the difference of a point source and an extended source. An experiment that would separate the screen properties from these other effects is to pass the light through a quartz diffuser. A scan looking directly at the diffuser could then be compared to a scan of the diffused light reflecting off the screen. This experiment will result in all spectra originating from an extended source. Additionally the exact alignment of the lamp in the monochromator FOV would not be as sensitive.

The possibility of an unwanted specular reflection internal to the monochromator is another consideration. This will be investigated with a platinum lamp.

Finally, diffuse scattering must be considered. The FEL Lamp calibration data indicates very low irradiance levels at 3000 angstroms. However, the direct measurements (Figure 4-2) show that the detector is still measuring a considerable photon flux at 3000 Angstroms. Possibly the black body lamp is so bright at longer wavelengths that the longer

wavelength photons are somehow scattering into the detector. When the source is reflected from the screen, the number of photons is greatly reduced. Perhaps with a lower flux the internal baffles are more effective and the PMT readings are more accurate. This would account for a large error in the reflectivity measurement.

D. PLATINUM LAMP

A possible explanation of the reflectivity discrepancy is the existence of an erroneous peak in the irradiance curve. For instance, suppose a longer wavelength peak from the FEL lamp was undergoing an internal reflection such that it was measured in the 3000 - 5000 Angstrom range. An erroneous peak in the black body region may influence the measurement locally.

A spectrum of a platinum lamp was taken in order to look for an internal specular reflection and to confirm the earlier resolution measurements. As mentioned in Chapter II.2, a platinum lamp was used for wavelength calibration of the MUSTANG instrument. The MUSTANG instrument was found to have a 10 Angstrom resolution. A spectrum of the platinum lamp was taken with the scanning monochromator and is depicted in Figure 4-9. The lines are both numerous and very narrow, as expected of an instrument with 2 Angstrom resolution. The spectra of the MUSTANG Instrument and the scanning monochromator have been correlated by convoluting the scanning monochromator platinum spectrum with a triangle wave of 10 Angstroms width (FWHM). The result of this convolution is given as Figure 4-10. The convoluted spectrum is strikingly similar to Figure 2-1. A noticeable difference is in

the 3150 Angstroms and greater range. The MUSTANG spectrum is very flat in that range while the monochromator shows significant response above 3300 Angstroms. However, the MUSTANG instrument is known to

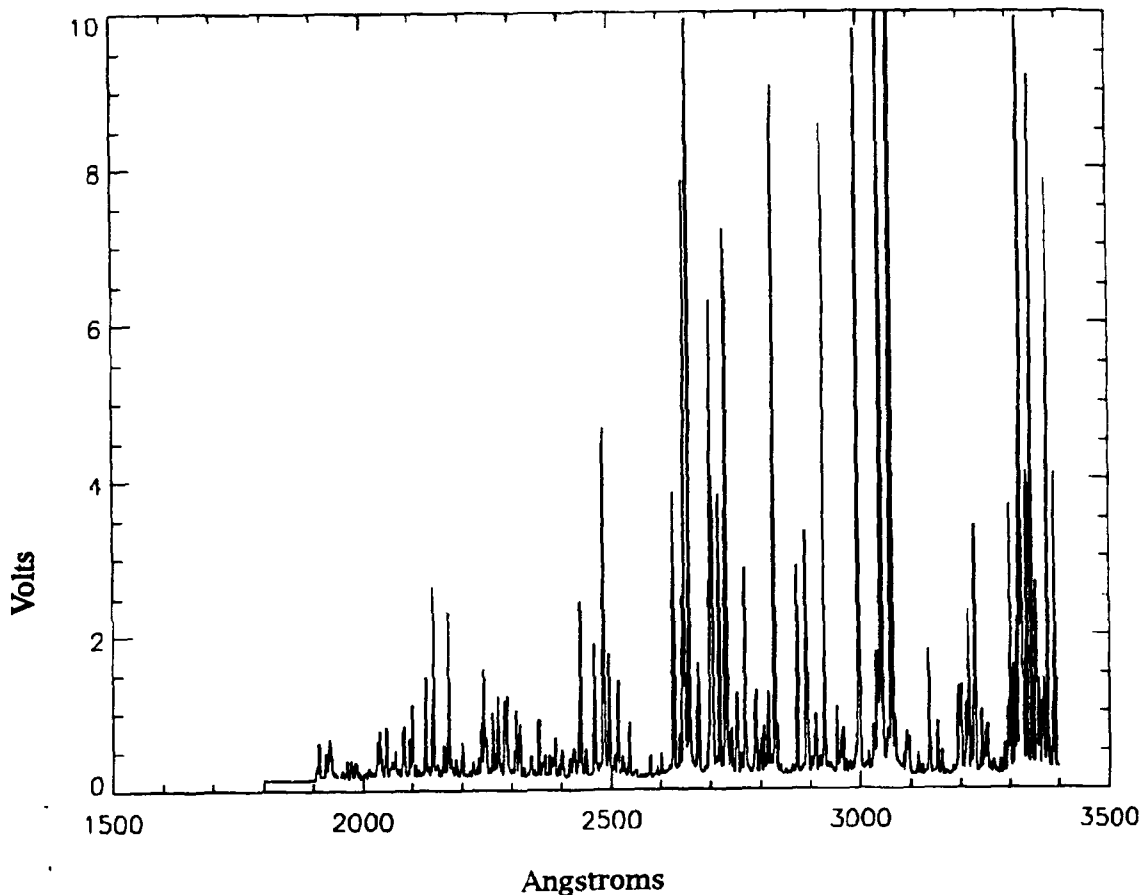
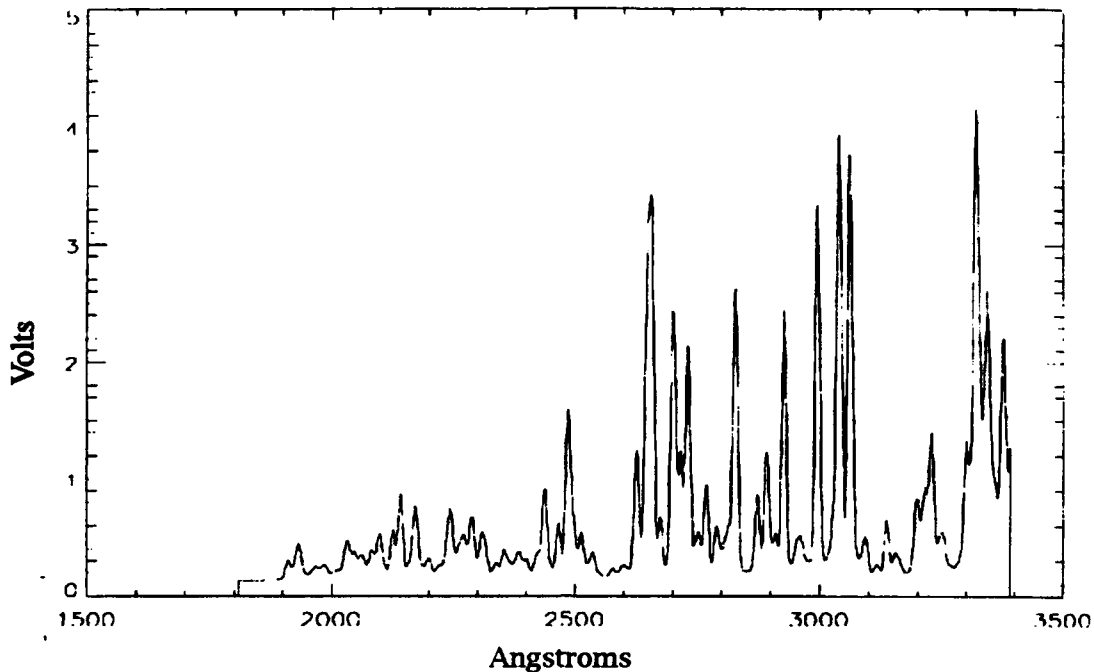

Figure 4-9 Platinum Spectra Taken With The Scanning Monochromator

have poor sensitivity above 3200 Angstroms. If the monochromator did have spurious internal reflections in the 1800-3400 Angstroms range it should be noticeable in a comparison of the two platinum spectra. Figure 4-11 is an overlay of the MUSTANG Spectrum and The monochromator spectrum. They correlate peak for peak. No evidence of a reflection was found in this wavelength region. This comparison also

confirms the resolution measurements for both the MUSTANG and monochromator instruments.



**Figure 4-10 Platinum Spectrum Convoluted
With a 10 Angstrom Triangle Wave**

The Automated Scanning Monochromator system shows that the platinum spectrum is at about .3 volts at 1800 Angstroms. This is clearly visible in Figure 4-9. The platinum spectrum taken with the MUSTANG instrument does not show this level of irradiance at 1800 Angstroms. This difference can also be seen in Figure 4-11, where the two spectra are plotted together.

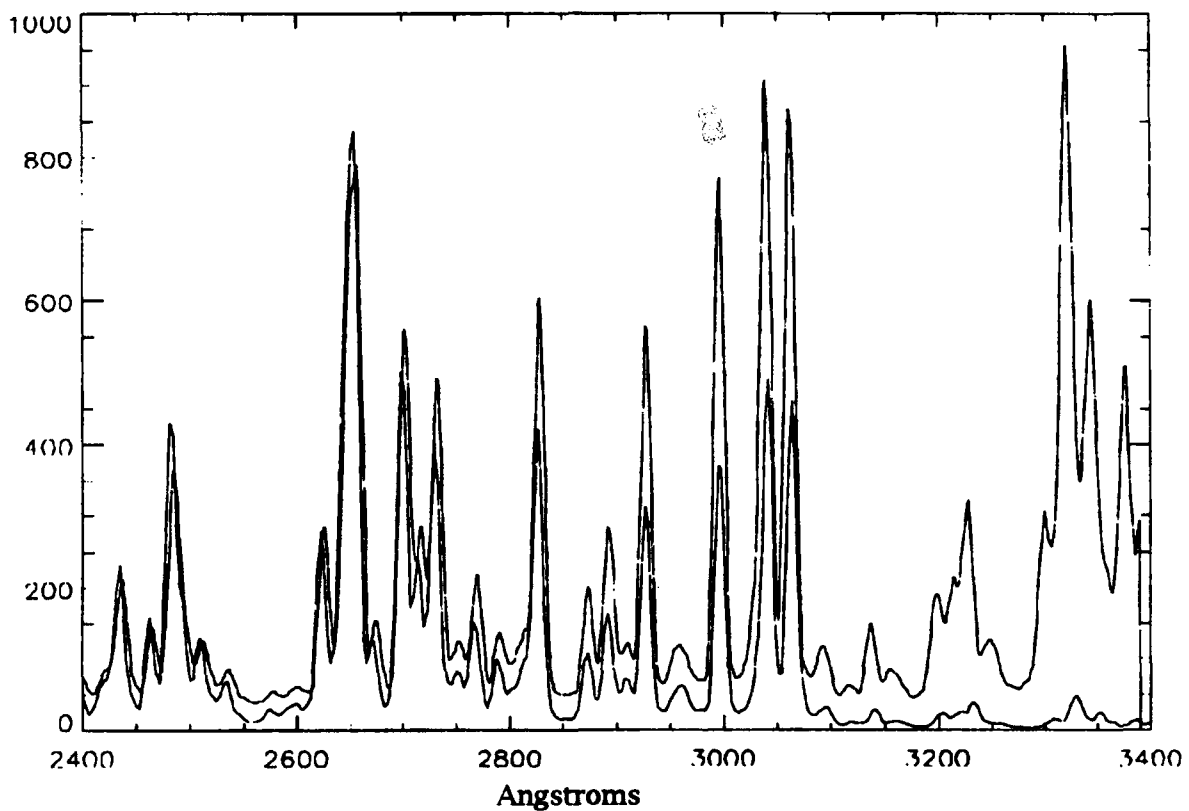
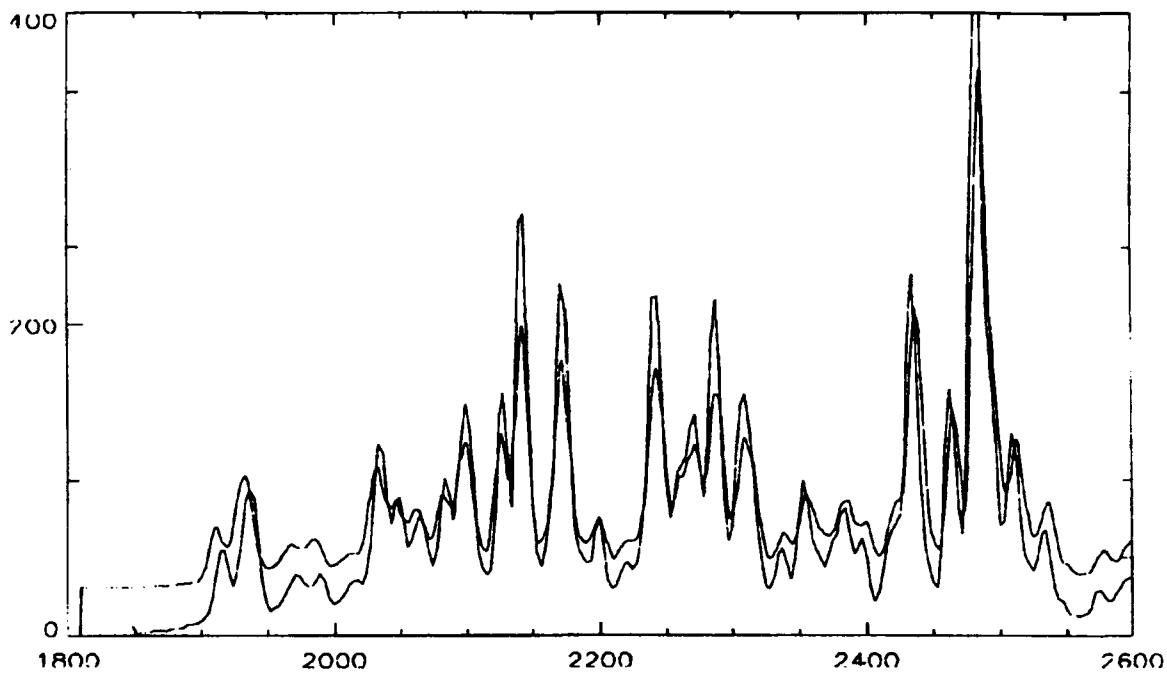

Figure 4-11 MUSTANG Platinum Spectra overlaying Scanning Monochromator Spectrum Convolved with a 10 Angstrom Triangle Wave

E. INSTRUMENTAL SENSITIVITY

The FEL lamp is a calibrated irradiance source. Specification of the spectral irradiance is given in Table 1 of reference 13. In this case, spectral irradiance is taken to be the incident flux on a small surface normal to the source at a distance of 50cm. A comparison of the known irradiance with the measured irradiance will yield the relative instrumental sensitivity. Figure 4-12 is a plot of the spectral irradiance as given by the manufacturer of the FEL lamp. The units have been converted from $\frac{\mu\text{W}}{\text{cm}^2 \cdot \text{nm}}$ (as given in Ref. 13) to $\frac{\text{photons}}{\text{cm}^2 \cdot \text{s}}$. This is because the PMT used in the automated scanning system is sensitive to the number of incident photons, rather than their energies. The PMT simply counts photons. Its' output is not sensitive to their wavelength. Incident photons are wavelength selected by the monochromator grating. The calibration data indicates that this source peaks at 9000 Angstroms.

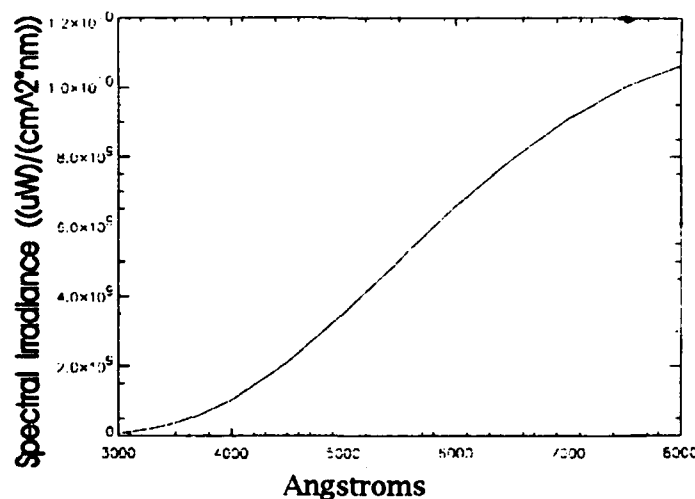

Figure 4-12 Specified Spectral Irradiance of FEL Lamp

It was noted that the calibration data indicates very little irradiance at 3000 Angstroms. However, the FEL direct spectrum is reading .96 volts at 3000 Angstroms. Recall the platinum lamp also showed larger

flux at shorter wavelengths than expected. Based on these two observations it appears that longer wavelength photons may be scattering into the PMT. Assuming that there is diffuse reflection at longer wavelengths, .8 volts was arbitrarily subtracted from the measured FEL direct-looking spectrum. This reduced the ratio of the measured data to the calibration data. A sensitivity curve was generated by dividing the spectral irradiance by the voltages from the FEL direct spectrum (Figure 4-2) and normalizing it to unity at the peak. The sensitivity curve for the scanning monochromator is plotted on a semi-log plot in Figure 4-13. Figure 3-1 is the sensitivity curve for the PMT used in the scanning monochromator. They compare favorably, showing peaks near 4000 Angstroms and dropping off rapidly above 7000

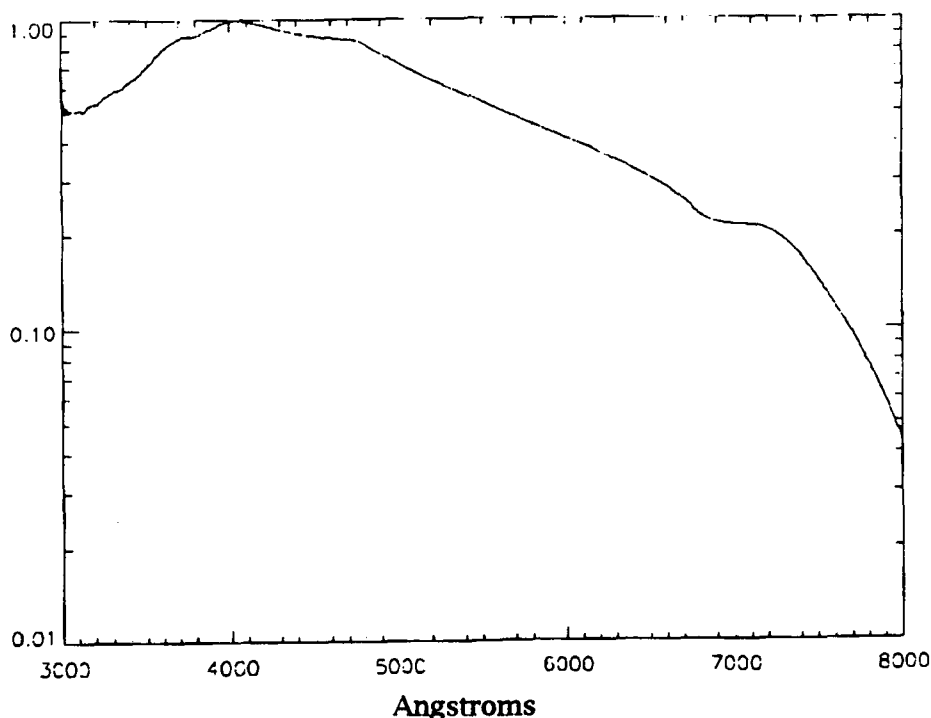

Figure 4-13 Relative Sensitivity of the Scanning Monochromator

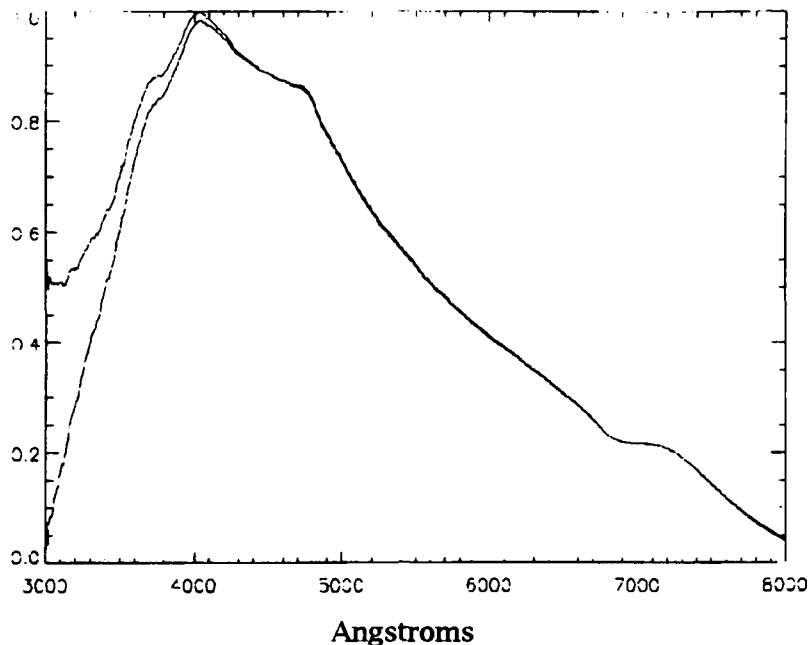

Figure 4-14 Relative Sensitivity Curve with Lower Bound

Angstroms. Figure 4-14 is a plot of the same curve overplotted with a lower bound to the error.

The FEL direct spectrum depicts a block body that peaks near 6000 Angstroms. Dividing this result by the instrument sensitivity will extend the peak towards the infrared wavelengths. As an example the measured spectrum is 2.2 volts at 8000 Angstroms. Correcting the irradiance with the sensitivity curve yields 50 volts, while the correction at 5800 Angstroms yields 20.1 volts.

V. CONCLUSION

The development of the Automated Scanning Monochromator has created a useful tool for spectral analysis. The Automated Scanning Monochromator is composed of an Acton Research Corporation (ARC) Monochromator, Ealing photomultiplier tube and a Macintosh PC, in conjunction with LabVIEW Software. The LabVIEW Virtual Instrument written to operate the ARC Monochromator is a mouse-driven user-friendly program developed specifically for automated spectral data measurements. Resolution and sensitivity of the Automated Scanning Monochromator system have been determined experimentally.

The Automated Scanning Monochromator was then used to measure the reflectivity of a BaSO₄-coated screen. Measurements indicated a large variance from expected reflectivity values. Preliminary error analysis of the experiment indicates that this discrepancy is due to internal specular reflections. Accurate reflectivity values may be obtainable through a more meticulous experimental setup. Diffuse analysis of a platinum lamp confirmed earlier resolution measurements of the monochromator.

Specific MUSTANG sensitivity calibration results are not presented by this thesis. However, further investigation into the reflectivity of the BaSO₄ is justified. The reflective measurements will be useful in calibration and analysis of the MUSTANG flight data.

APPENDIX A

OPERATING INSTRUCTIONS

**AUTOMATED SCANNING WITH THE
ACTON RESEARCH CORPORATION
SCANNING MONOCHROMATOR**

June 1992

A. HARDWARE CONNECTIONS

Several hardware components are required to work in concert for automated scanning. The following table lists component requirements.

- Macintosh PC with NB-MIO-16 Analog/Digital converting board installed in slot number 3.
- LabVIEW 2.1.1 or compatible software
- LabVIEW Virtual Instrument *ARC Main*
- ARC Scan Control Module
- RS-232C Adapter
- Macintosh Modem-to-RS-232C Cable
- ARC .3 meter Monochromator
- Ealing Photomultiplier
- Ealing Photomultiplier power supply
- Coaxial Cable (PMT power supply to MIO Board)

A diagram depicting the interconnection of components is given as Figure 1. The center of the system is the Macintosh (Mac). The Mac provides drive commands to the scanning instrument and takes voltage

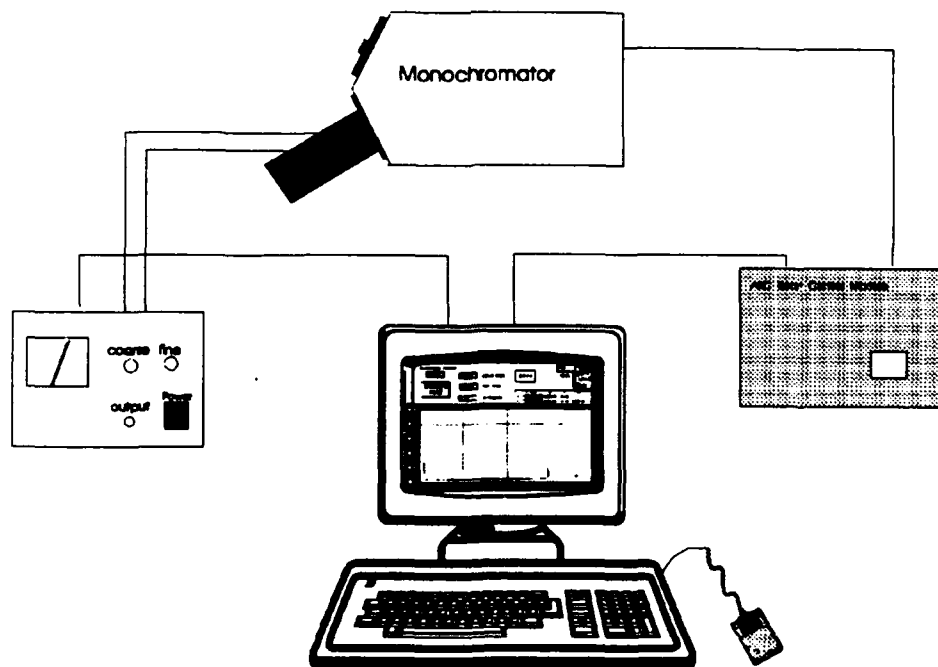
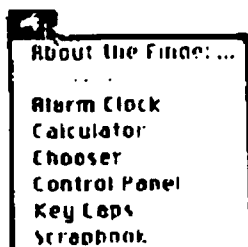

Figure 1 Interconnection of hardware components

data readings from the PMT. Scanning commands are issued via the modem port at the rear of the Mac. A modem-to-RS-232C cable connects the Mac with the ARC Scan Control Module. An adapter that cross-connects pin 2 and pin 3 is required at the RS-232C connection to the ARC Monochromator Scan Module. The PMT power supply has an LED backbit switch that indicates power status. The Scan Control Module has a white light indicator for power status. All hardware equipment must be turned on prior to executing the LabVIEW Virtual Instrument *ARC Main*.

B. SOFTWARE SETUP

Prior to initiating any LabVIEW software the Mac must be configured properly. This is accomplished by clicking on the apple icon



in the upper left hand corner of the screen. The window box depicted at left will appear. Goto "Chooser" and select the "Redirector" option. The "Modem" option must be selected for *ARC Main* to function. Figure 2 depicts the Chooser panel with the Redirector selected. If the modem icon is not

selected then select it and reboot the computer. If the modem is selected then simply close the file and continue.

With the Mac configured for operation load the LabVIEW package along with the attached file for *ARC Main*. This is accomplished by a double click of the mouse on the icon for *ARC Main*.  The screen should now look like Figure 3. This is the Front Panel of the LabVIEW Virtual Instrument *ARC Main*.

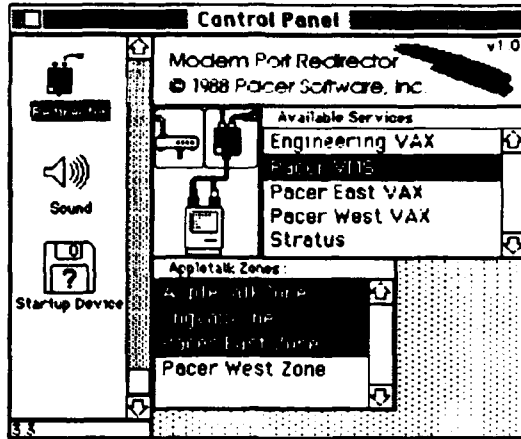

Figure 2 Chooser Redirector Panel

C. VIRTUAL INSTRUMENT OPERATION

At the upper left hand corner of the front panel is the display for the instrument wavelength.

- 1) Enter a value for the INSTRUMENT WINDOW immediately. Place the pointing hand icon over the digital control Instrument Window (upper left hand corner of Figure 3) and double click. The numerical window will then turn red. Type in the wavelength as it is displayed in the window of the Monochromator. (to tenths of an Angstrom).

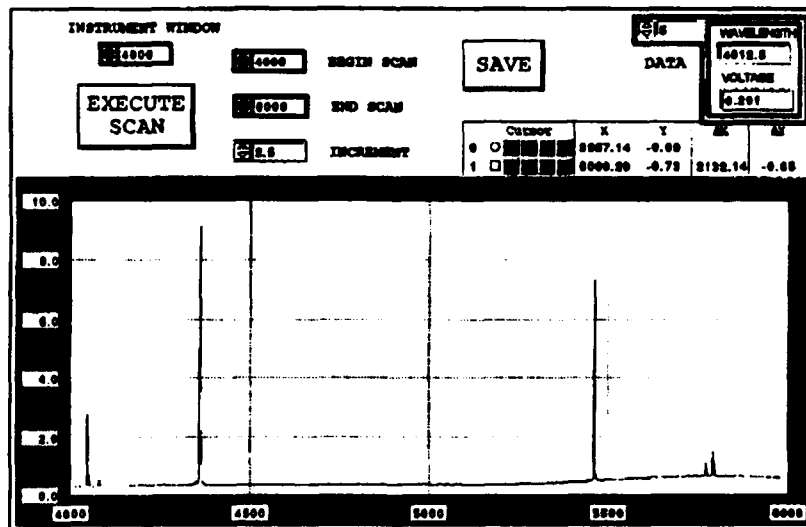

Figure 3 ARC Main Front Panel

2) Begin running the program: A single click on the arrow, shown in the example panel of Figure 4, will run the LabVIEW VIRTUAL INSTRUMENT. The Instrument window reading must be entered, as described in item 1), prior to running the VIRTUAL INSTRUMENT or the program will crash. If the program does crash, simply end the program run with a single click on the stop sign icon. (Figure 4). Then close the file *ARC Main* by a single click in the box at the upper left side of Figure 3. Re-open the file *ARC Main* as described earlier and start again.

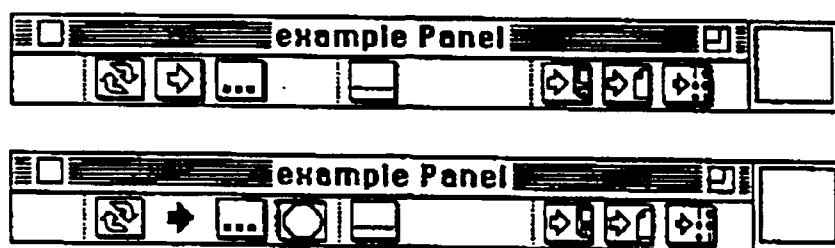

Figure 4 Example Panel

3) Enter the values of BEGIN SCAN, END SCAN, and INCREMENT by double clicking the mouse when the pointing hand icon is over the respective digital control. All of these values are also accurate to the tenths' digit.

4) Single click on the EXECUTE SCAN push button: This executes the scan. The instrument will first slew to the begin scan wavelength. At this point a panel will pop on the front panel that overlaps the EXECUTE SCAN push button. This will indicate the current instrument wavelength throughout the scan.

At the end of the scan the data will be graphed with wavelength along the x-axis and voltage along the y-axis. Two cursors are available for graphic analysis. The cursor can be dragged with the mouse or double click in the box at the numeric indication for the cursor

position. The number will again be highlighted in red. Enter the desired cursor value and enter. The cursor is useful for on-screen analysis.

The data array is also available on screen for analysis. Clicking on the controller arrows with the pointing hand icon will file through all of the data points. For display of a specific data point double click in the numerical window. When the data box turns red, type in the desired point and press 'Enter'.

5) SAVE data: is accomplished by a single click of the save push button. A menu box will appear. Choose the folder ARC Data Files and enter the name of the new data file.

The data is saved as an ASCII file that can be recalled by any word processing software. The data is saved in a column. The first string is the voltage reading, the second string is the corresponding wavelength. An example is given in Table 1.

6) Close the Virtual Instrument: single click in the box at the left side of the panel in the same row as the Virtual Instrument title. See Figure 3.

D. ANALOG INPUT

The analog input is controlled with a LabVIEW Virtual Instrument *DAQ.OP*. ARC Main counts 10,000 samples at an interval of 20 microseconds. It then uses the average of the 10,000 samples as the data value. The number of samples and interval will affect both the scan speed and statistical properties of the data. The operator may

wish to change these parameters based on the photon flux density and other properties of the subject emitter. For complete information on *DAQ-OP* see LabVIEW 2 LabDriver Virtual Instrument Library Reference Manual page 5-21.

E. RECAP CHECKLIST

- Select Modem on Chooser
- Ensure all hardware components are properly hooked up.
- Ensure all components have power.
- Load LabVIEW Virtual Instrument *ARC Main*.
- Enter a value for the INSTRUMENT WINDOW immediately.
- Begin running the program.
- Enter the values of Begin Scan, End Scan, and Increment.
- Single click on the EXECUTE SCAN push button.
- SAVE data.
- Close the Virtual Instrument.

.0822	voltage
1800	wavelength
.0945	voltage
1810	wavelength
.1087	voltage
1820	wavelength
.1134	voltage
1830	wavelength

Table 1 Sample ASCII Data File

LIST OF REFERENCES

1. Joint Chiefs of Staff, Unclassified, Memorandum MJCS 154-86 to Under Secretary of Defense (research and Engineering), Subject: Military Requirements for Defense Environmental Satellites, 1 August 1986.
2. Clayton, Michael J., *Analysis of the Ultraviolet Emissions of Nitric Oxide from Mid-Latitude Rocket Observations*, Master's thesis, Naval Postgraduate School, Monterey, California, June, 1990.
3. Phelps Frederick M., *M.I.T. Wavelength Tables*, M.I.T. Press, Cambridge Mass, 1982.
4. Grum, F., and Luckey, G.W., *Optical Sphere Paint and a Working Standard of Reflectance*, Applied Optics, Volume 7, No. 11, November, 1968.
5. Cleary, D.D., and Barth, C.A., *The N₂ 2143 Angstrom Emission in the Dayglow*, Journal of Geophysical Research, 92, 13635, 1987.
6. *Operating Instructions for Acton Research Corporation Model VM-503 .3 meter Monochromator*, Acton Research Corporation.
7. Horowitz, Paul, and Hill, Winfield, *The Art of Electronics*, 2nd ed, Cambridge University Press, Cambridge, 1989.
8. *Ealing Electro-Optics Product Guide 87-88*, Ealing Electro-Optics Inc, 1988.
9. *NB-MIO-16 User Manual*, April 1989 edition, Part Number 320096-01, National Instruments Corporation, 1989.
10. *LabVIEW 2 Advanced Training Manual*, January 1991 Edition, Part Number 20303-01, National Instruments Corporation, 1990.
11. Quint, John H., *Development of an NPS Middle Ultraviolet Spectrograph (MUSTANG) Electronic Interface Package*, Master's Thesis, Naval Postgraduate School, Monterey, California, December, 1991.

12. *LabVIEW 2 Labdriver VI Library Reference Manual, Version 4.0, January 1990 Edition, Part Number 320249-01, National Instruments Corporation, 1990.*
13. *Report of Calibration of One Standard of Spectral Irradiance Model FEL-IR, S/N: F-259, Optonic Laboratories, Inc. ,1990.*

INITIAL DISTRIBUTION LIST

- | | |
|---|---|
| 1. Defense Technical Information Center
Cameron Station
Alexandria, VA 22304-6145 | 2 |
| 2. Library, Code 52
Naval Postgraduate School
Monterey, CA 93943-5002 | 2 |
| 3. Chairman
Department of Aeronautical and Astronautical Engineering
Naval Postgraduate School
Monterey, CA 93943-5000 | 1 |
| 4. Dr. David D. Cleary
Physics Department, PH-CL
Naval Postgraduate School
Monterey, CA 93943-5000 | 3 |
| 5. Lt Thane D. Rivers
9191 Lee Smith Dr.
Juneau, Ak 99801 | 2 |