

AD-A257 635



2

NAVAL POSTGRADUATE SCHOOL  
Monterey, California



DTIC  
SELECTE  
DEC 0 1 1992  
S B D

THESIS

CODED ORTHOGONAL SIGNALING

by

Salih Semerciler

September, 1992

Thesis Advisor :  
Co-Advisor :

Tri T. Ha  
R. Clark Robertson

92-30453

Approved for public release; distribution is unlimited.

UNCLASSIFIED

SECURITY CLASSIFICATION OF THIS PAGE

REPORT DOCUMENTATION PAGE				Form Approved OMB No 0704-0188	
1a REPORT SECURITY CLASSIFICATION <b>UNCLASSIFIED</b>			1b RESTRICTIVE MARKINGS		
2a SECURITY CLASSIFICATION AUTHORITY			3 DISTRIBUTION AVAILABILITY OF REPORT Approved for public release; distribution is unlimited		
2b DECLASSIFICATION/DOWNGRADING SCHEDULE					
4 PERFORMING ORGANIZATION REPORT NUMBER(S)			5 MONITORING ORGANIZATION REPORT NUMBER(S)		
6a NAME OF PERFORMING ORGANIZATION <b>Naval Postgraduate School</b>		6b OFFICE SYMBOL (if applicable) <b>EC</b>	7a NAME OF MONITORING ORGANIZATION <b>Naval Postgraduate School</b>		
6c ADDRESS (City, State, and ZIP Code) <b>Monterey, CA 93943-5000</b>			7b ADDRESS (City, State, and ZIP Code) <b>Monterey, CA 93943-5000</b>		
8a NAME OF FUNDING/SPONSORING ORGANIZATION		8b OFFICE SYMBOL (if applicable)	9 PROCUREMENT INSTRUMENT IDENTIFICATION NUMBER		
8c ADDRESS (City, State, and ZIP Code)			10 SOURCE OF FUNDING NUMBERS		
			PROGRAM ELEMENT NO	PROJECT NO	TASK NO
					WORK UNIT ACCESSION NO
11 TITLE (Include Security Classification) <b>CODED ORTHOGONAL SIGNALING</b>					
12 PERSONAL AUTHOR(S) <b>SEMERICILER, Salih</b>					
13a TYPE OF REPORT <b>Master's Thesis</b>		13b TIME COVERED FROM _____ TO _____	14 DATE OF REPORT (Year, Month, Day) <b>September 1992</b>		15 PAGE COUNT <b>47</b>
16 SUPPLEMENTARY NOTATION The views expressed in this thesis are those of the author and do not reflect the official policy or position of the Department of Defense or the U.S. Government.					
17 COSATI CODES			18 SUBJECT TERMS (Continue on reverse if necessary and identify by block number)		
FIELD	GROUP	SUB-GROUP	coding, TCM, MFSK		
19 ABSTRACT (Continue on reverse if necessary and identify by block number) In this thesis, a new scheme of encoding orthogonal MFSK signals with convolutional codes is proposed. Instead of separating the code and the signals as is done conventionally, here the $m$ outputs of the convolutional encoder of rate $k/m$ are used to select the $M = 2^m$ orthogonal FSK signals. This combined coded system is called trellis-coded modulation MFSK (TCM/MFSK). The free distance of TCM/MFSK codes is found computationally. Asymptotic coding gains (ACG) of several TCM/MFSK systems relative to uncoded MFSK systems having the same bandwidth efficiency (bits/s/Hz) are calculated. Both analytic descriptions and natural mapping implementations of TCM/4-FSK with rate $1/2$ and TCM/8-FSK with rate $2/3$ for several constraint lengths of the convolutional codes are given. The analytic description of TCM/MFSK is also obtained computationally.					
20 DISTRIBUTION AVAILABILITY OF ABSTRACT <input checked="" type="checkbox"/> UNCLASSIFIED/UNLIMITED <input type="checkbox"/> SAME AS RPT <input type="checkbox"/> DTIC USERS			21 ABSTRACT SECURITY CLASSIFICATION <b>UNCLASSIFIED</b>		
22a NAME OF RESPONSIBLE INDIVIDUAL <b>HA, Tri</b>			22b TELEPHONE (Include Area Code) <b>408-646-2788</b>		22c OFFICE SYMBOL <b>EC/Ha</b>

DD Form 1473, JUN 86

Previous editions are obsolete

SECURITY CLASSIFICATION OF THIS PAGE

S/N 0102-LF-014-6603

UNCLASSIFIED

Approved for public release; distribution is unlimited.

**CODED ORTHOGONAL SIGNALING**

by

**Salih Semerciler**  
Lieutenant Junior Grade, Turkish Navy  
B.S., Turkish Naval Academy, 1985

Submitted in partial fulfillment of the  
requirements for the degree of

**MASTER OF SCIENCE IN ELECTRICAL ENGINEERING**

from the

**NAVAL POSTGRADUATE SCHOOL**

September, 1992

Author:

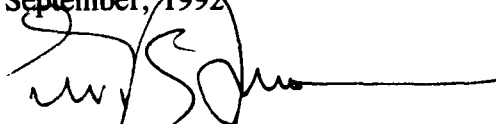

Salih Semerciler

Approved by:

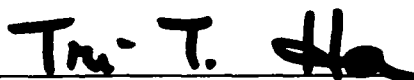

Tri T. Ha, Thesis Advisor

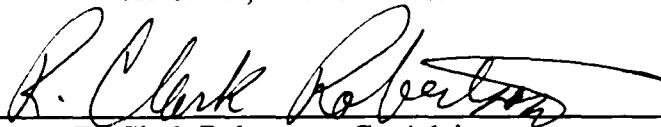

R. Clark Robertson, Co-Advisor



Michael A. Morgan, Chairman  
Department of Electrical and Computer Engineering

## ABSTRACT

In this thesis, a new scheme of encoding orthogonal MFSK signals with convolutional codes is proposed. Instead of separating the code and the signals as is done conventionally, here the  $m$  outputs of the convolutional encoder of rate  $k/m$  are used to select the  $M = 2^m$  orthogonal FSK signals. This combined coded system is called trellis-coded modulation MFSK (TCM/MFSK).

The free distance of TCM/MFSK codes is found computationally. Asymptotic coding gains (ACG) of several TCM/MFSK systems relative to uncoded MFSK systems having the same bandwidth efficiency (bits/s/Hz) are calculated.

Both analytic descriptions and natural mapping implementations of TCM/4-FSK with rate  $1/2$  and TCM/8-FSK with rate  $2/3$  for several constraint lengths of the convolutional codes are given. The analytic description of TCM/MFSK is also obtained computationally.

<b>Accession For</b>	
NTIS GRA&I	<input checked="" type="checkbox"/>
DTIC TAB	<input type="checkbox"/>
Unannounced	<input type="checkbox"/>
Justification _____	
By _____	
Distribution/ _____	
<b>Availability Codes</b>	
Dist	Avail and/or Special
A-1	

## TABLE OF CONTENTS

I. INTRODUCTION . . . . .	1
II. OVERALL REVIEW . . . . .	5
III. ENCODER DESIGN . . . . .	13
IV. ENCODER DESIGN EXAMPLES . . . . .	21
A. ENCODER DESIGN 1 . . . . .	21
B. ENCODER DESIGN 2 . . . . .	25
C. ENCODER DESIGN 3 . . . . .	29
D. ENCODER DESIGN 4 . . . . .	31
V. DISCUSSION AND CONCLUSIONS . . . . .	35
APPENDIX A . . . . .	38
APPENDIX B . . . . .	40
LIST OF REFERENCES . . . . .	41
INITIAL DISTRIBUTION LIST . . . . .	42

## I. INTRODUCTION

The model of the digital communication system under consideration is shown in Figure 1.1. The input to the convolutional encoder,  $\{a_i\}$ ,  $a_{i,k} = 0, 1$  is a sequence of  $k$  independent bits. The channel encoding operation is combined with  $M$ -ary Frequency Shift Keying (MFSK) modulation as in Trellis Coded Modulation (TCM) schemes. A convolutional encoder is used to generate the underlying code. MFSK orthogonal signaling is used to achieve an acceptable performance with a minimum power requirement.

The set of orthogonal signals used is denoted as:

$$\{S_x(t)\}, x=1, 2, \dots, M \quad (1.1)$$

These signals are generated by a frequency synthesizer which is driven by a set of real numbers

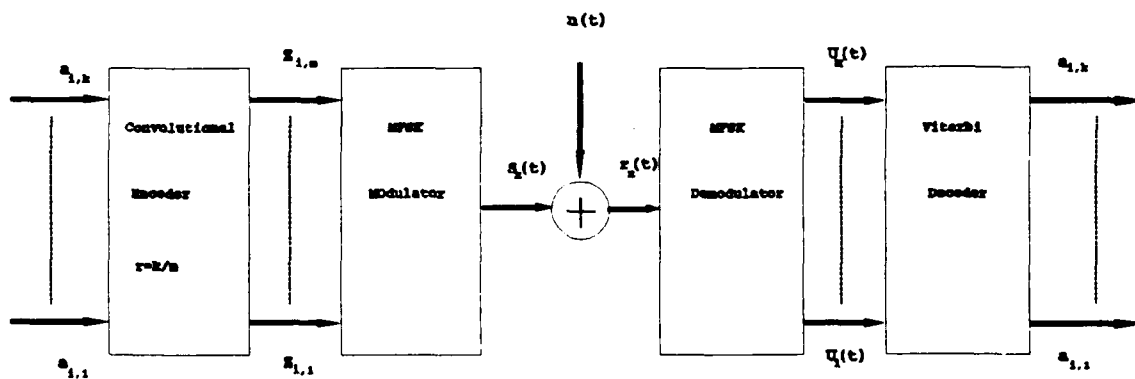

Figure 1.1 System Model

$$\{x\}, x=1,2,\dots,M \quad (1.2)$$

These real numbers have a specific relationship with the incoming bit stream  $\{a_i\}$  and the memory bits of the encoder. For an encoder that has  $2^v$  states, the constraint length of the convolutional code is defined as  $v$ . The constraint length  $v$  is equal to the memory of the encoder (shift register stages).

The  $M = 2^m$  distinct symbols are represented by  $M$  orthogonal sinusoidal waveforms as:

$$S_x(t) = A \cos[2\pi(f_c + (x-1)\Delta f)t], 0 \leq t \leq T \quad (1.3)$$

where

$$x = 1, 2, \dots, M$$

T: signaling interval

$f_c$ : carrier frequency

$\Delta f$ : the width of the frequency slot.

The orthogonal signal set is characterized by equal signal energy  $E$  given by:

$$E = \int_0^T S_x^2(t) dt = \frac{A^2 T}{2} \quad (1.4)$$

The orthogonality condition is satisfied when the cross-correlation coefficient obeys the relationship

$$P_{ij} = \int_0^T s_i(t)s_j(t)dt = \begin{cases} 0 & \text{if } i \neq j \\ E & \text{if } i = j \end{cases} \quad (1.5)$$

MFSK is generated by subdividing a frequency interval into M distinct frequency slots. Each slot has a width  $\Delta f$ . The minimum frequency separation between adjacent signals is obtained from (1.5) [Ref. 1]

$$\Delta f_{\min} = \frac{1}{T} \quad (1.6)$$

Thus, the minimum one-sided bandwidth occupied by these M orthogonal signals is:

$$B = \frac{M}{T} \quad (1.7)$$

It is assumed that the transmission medium introduces zero mean, additive white Gaussian noise (AWGN)  $n(t)$  with power spectral density  $\frac{N_o}{2}$ . The received signal is corrupted by AWGN as:

$$r_x(t) = s_x(t) + n(t) \quad (1.8)$$

This signal,  $r_x(t)$ , is demodulated by a bank of either matched filters or correlators. When the initial phase can be estimated by the receiver, the demodulation is coherent, otherwise it is noncoherent.

The analog outputs  $\{u_x(t)\}$ ,  $x = 1, 2, \dots, M$  of the demodulator are then sent to the Viterbi decoder which performs a soft decision decoding of the MFSK signal. The sequence  $\{\hat{a}_i\}$  at the output of the Viterbi decoder is the maximum-likelihood estimate of

the input sequence  $\{a_i\}$ . In this thesis, only coherent TCM/MFSK systems are considered.

The remaining chapters in this thesis are organized as follows. In Chapter II, an overview of convolutional coding and TCM/MFSK are presented. The results from the computer program written to find the free distance of TCM/MFSK are given. Asymptotic coding gain (ACG) is defined and a list of ACGs is also given. Chapter III deals with the design of the encoder for TCM/MFSK. Both the analytic expressions and the natural mapping rules for certain schemes are examined. Although all the signals in the M-ary orthogonal constellation have equal distances from each other, it is shown that the transmitter complexity depends on the signal assignment. Basic rules are given for the minimal transmitter complexity. In Chapter IV, several encoders are designed on a step by step basis. TCM/MFSK is further discussed and some conclusions are drawn in Chapter V.

The computer program to find the free euclidean distance of TCM/MFSK is given in Appendix A. Another program to find the analytic expression of TCM/MFSK is given in Appendix B.

## II. OVERALL REVIEW

In 1948, Shannon showed that the main limitation to transmission over a noisy channel is set by a quantity called channel capacity. Capacity of a noisy channel is the largest rate at which information can be transmitted reliably. In other words, if the data source rate is less than the channel capacity, proper encoding and decoding techniques enable us to communicate over a noisy channel with any arbitrary error rate. Otherwise, reliable communication is not possible.

Codes are divided into two categories according to their function. Codes for source encoding attempt to reduce the data source rate at the price of tolerable distortion. Codes for channel encoding turn a noisy, constrained channel into a reliable, unconstrained channel. The application of channel encoding is called Forward Error Correcting Coding (FEC). Most communication systems use FEC coding systems. FEC coding is generally achieved by redundancy adding and noise averaging. Codes are classified according to their structure as block codes and convolutional codes.

In this thesis, channel encoding and MFSK modulation operations are combined together to take advantage of soft decision decoding. Convolutional coding is used for this purpose. It may be possible to use another code as the outer code to improve performance further.

The basic distinction between convolutional codes and block codes is that convolutional codes do not have a fixed block length. These codes are generated by

passing the input sequence through a system of linear shift registers and modulo-2 adders. A convolutional code is characterized by a ratio called the code rate. The code rate is the ratio of the number of input lines to the number of output lines of the encoder.

Thus, the code rate is

$$r = \frac{k}{m} \quad (2.1)$$

where  $k$  is the number of inputs and  $m$  is the number of outputs of the encoder. The performance of the encoder depends strongly on the number of states  $2^v$  where the constraint length  $v$  is equal to the memory of the encoder.

The basic utility of convolutional codes comes from the fact that these codes can be decoded by the Viterbi decoding algorithm. The Viterbi algorithm is an efficient way of *sequence demodulating in the presence of noise* [Ref. 2]. The Viterbi decoding algorithm is equivalent to maximum-likelihood decoding and thus optimum for equally likely messages [Ref. 3].

When the encoding and modulation are done separately, the basic parameter affecting the code performance is the Hamming distance, which is the number of places in which any two sequences differ. If the encoding and the modulation are combined into one step, the Euclidean distance governs the performance of the coded scheme. The Euclidean distance between two sequences  $c$  and  $d$  is defined as

$$d(c,d) = [\sum_{i=1}^{\infty} |c_i - d_i|^2]^{1/2} \quad (2.2)$$

where  $c_i$  and  $d_i$  are the elements of  $c$  and  $d$ , respectively.

At the receiver end, if the Viterbi decoder deals with the quantized demodulator outputs which are the best estimates of the transmitted signal (i.e., the number of quantization levels is 2), it is called hard-decision decoding. If the Viterbi decoder works on the sequence of information on which a final decision can be made about the transmitted signals (i.e., the number of quantization levels is more than 2), the method is called soft-decision decoding. Soft-decision decoding has more coding gain than hard-decision decoding [Ref. 1].

Trellis coded modulation (TCM) proposed by Ungerboeck combines encoding and modulation to design a code for a particular geometry of the signal constellation. Thus, the Euclidean distance becomes the main parameter and soft-decision decoding is always used. The trellis encoder is composed of two parts. The first part is the convolutional encoder with  $v$  bits of memory. This determines the number of the states  $2^v$  of the encoder. The second part is the mapper. This part is memoryless. Coded digits select the signal from the constellation and move the encoder to the next state. Uncoded digits only select signals causing parallel transitions. The mapper maps the incoming coded and uncoded digits to the  $M$  signals. The mapping rule is defined by a function which must be nonlinear in order to achieve a coding gain [Ref. 4].

The asymptotic coding gain is the ratio of  $E_b/N_0$  required for coded operation relative to that required for uncoded operation with the same bandwidth efficiency in the limit of large  $E_b/N_0$ . Although actual coding gain is a more realistic indicator of system performance, it is significantly more difficult to obtain than is ACG, and ACG does give

an indication of the performance that can be expected for AWGN channels. The ACG of TCM/MFSK is defined as:

$$ACG = 10 \log\left(\frac{1}{4} d_{free}^2 / 2E\right) \quad \text{for TCM/4-FSK} \quad (2.3a)$$

$$ACG = 10 \log\left(\frac{1}{2} d_{free}^2 / 2E\right) \quad \text{for TCM/8-FSK} \quad (2.3b)$$

where

$d_{free}$ : free Euclidean distance of the coded scheme (the smallest of the Euclidean distances between any two coded paths)

$E$  : average energy of the coded signal

Decoding is done using the Viterbi algorithm. It is basically a search of the most likely path through the trellis. Sometimes the chosen path may not be the transmitted path due to the effect of noise. Then an error event is said to have taken place. An error event is the part of the path which diverges from the correct path and remerges at a later time. The free distance of a TCM scheme is the minimum Euclidean distance of all error events. Thus, by definition, free distance plays an important role in determining the performance of any TCM scheme.

A general analytic solution for the free distance can not be obtained; hence, it is found computationally. A computer program is given in Appendix A to find the free distance of any TCM/MFSK. When the signal set is orthogonal, the distance between any pair of  $M$  signals is:

$$d_{ij} = \sqrt{2E} \quad \text{for all } i,j \quad (2.4)$$

This is also the minimum distance of any orthogonal signal constellation. In the computer program this distance is normalized to unity regardless of the number of the signals in the constellation. Thus,

$$d_{ij} = \sqrt{2E} = 1 \quad \text{for all } i,j \quad (2.5)$$

The number of states in the trellis diagram is  $2^v$ . The number of the transitions that diverge from a common state or remerge into a same state is  $2^k$ . Since the code rate is  $r = k/m$  with  $m \geq k + 1$ ,  $M = 2^m$  signals are assigned to  $2^{k+v}$  transitions. The figure of merit to compare different coding schemes is ACG given by (2.3). The reference uncoded constellation is the one which has the same bandwidth efficiency as the coded scheme. Convolutional coding does not effect the spectrum of the transmitted signal [Ref. 5]. Hence, the bandwidth efficiency  $R/B$  may be taken as a reference for comparison purposes. Here  $R$  is the information rate in bits per second and  $B$  is the minimum one-sided bandwidth in Hz given by (1.7). For an uncoded  $M$ -ary orthogonal signaling, where  $M = 2^{k'}$  the information rate is

$$R = \frac{k'}{T} \quad (2.6)$$

where  $k' = \log_2 M$  and  $T$  is the symbol duration. Also  $B = M/T$ , hence:

$$\frac{R}{B} = \frac{k'}{M} = \frac{k'}{2^{k'}} \quad (2.7)$$

When a convolutional encoder with rate  $r = k/m$  is used, the information rate is  $R = k/T$ , but the bandwidth is expanded to  $B = 2^m/T$ . Thus, the coded bandwidth efficiency is

$$\frac{R}{B} = \frac{k}{2^m} \quad (2.8)$$

ACG is calculated for the coded schemes for which (2.7) and (2.8) are equal. For example, a rate  $1/2$  TCM/4-FSK with  $k = 1$ ,  $m = 2$  has a bandwidth efficiency of  $1/4$  b/s/Hz. Uncoded 16-FSK with  $k' = 4$  has the same bandwidth efficiency.

A search with the program given in Appendix A shows that the squared free distance of the best codes is

$$\frac{d_{free}^2}{2E} = L + 1 \quad (2.9)$$

where  $L = \lfloor v/k \rfloor$ , and  $\lfloor \bullet \rfloor$  denotes the integer part. The results are tabulated in Table 2.1. Note that the bandwidth efficiency for all TCM/4-FSK and TCM/8-FSK schemes is  $1/4$  b/s/Hz.

The program input consists of a  $2^v \times 2^k$  matrix  $N$ . The rows of  $N$  are the transitions from the states of the trellis respectively. An example of a trellis diagram and the corresponding matrix  $N$  are given in Figure 2.1. The states are labeled as 1, 2, ...,  $2^v$ . The first row of  $N$  consists of the labels of the destinations of the transitions from the first state. The second row for the transitions from the second state, so on.

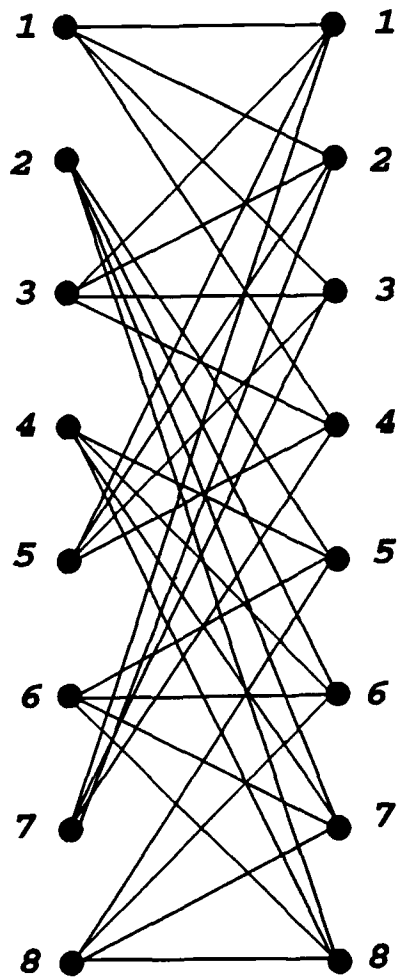

$N=$

1	2	3	4
5	6	7	8
1	2	3	4
5	6	7	8
1	2	3	4
5	6	7	8
1	2	3	4
5	6	7	8

Figure 2.1 A Trellis Diagram and its Matrix

**TABLE 2.1 ASYMPTOTIC CODING GAINS OF TCM/4-FSK AND TCM/8-FSK WITH RESPECT TO UNCODED 16-FSK**

Code Rate (r)	Modulation (MFSK)	Constraint Length (v)	$\frac{d_{free}^2}{2E}$	ACG (dB)
1/2	4-ary	2	3	-1.25
1/2	4-ary	3	4	0.0
1/2	4-ary	4	5	0.97
1/2	4-ary	5	6	1.76
1/2	4-ary	6	7	2.43
1/2	4-ary	7	8	3.01
1/2	4-ary	8	9	3.52
1/2	4-ary	9	10	3.98
1/2	4-ary	10	11	4.39
2/3	8-ary	2	2	0.0
2/3	8-ary	3	2	0.0
2/3	8-ary	4	3	1.76
2/3	8-ary	5	3	1.76
2/3	8-ary	6	4	3.01
2/3	8-ary	7	4	3.01
2/3	8-ary	8	5	3.98
2/3	8-ary	9	5	3.98
2/3	8-ary	10	6	4.77

### III. ENCODER DESIGN

The function of the encoder is to map the input binary stream into  $M$  orthogonal signals. This may be viewed as a sliding window method of encoding a binary data stream into a sequence of  $M$  real numbers. If the number of input bits into the encoder is  $k$  and the code constraint length is  $v$ , then the channel input  $S_x(t)$  will depend on  $n = k + v$  bits. The  $v$  bits in memory determine one of  $2^v$  states of the encoder while  $2^k$  transitions are associated with  $k$  input bits.

The MFSK waveform is given by (1.3) and it is the output of a voltage controlled oscillator (VCO) driven by a set of real numbers (voltage levels). Hence, the encoding operation may be implemented by mapping  $n$  bits into the set of real numbers  $\{x\}$ ,  $x=1, 2, \dots, M$ . Because  $x$  is a real-valued function of  $n$  bits, it may be written as a sum of products of input bits  $a_i$  where  $a_i \in \{0,1\}$  or  $b_i$  where  $b_i \in \{-1,1\}$  and  $b_i = 1-2a_i$  [Ref. 6]. Thus,

$$\begin{aligned}
 x(b_1, b_2, \dots, b_n) = & d_0 + \sum_{i=1}^n d_i b_i + \sum_{\substack{i,j=1 \\ j>i}}^n d_{ij} b_i b_j \\
 & + \sum_{\substack{i,j,h=1 \\ h>j>i}}^n d_{ijh} b_i b_j b_h + d_{12\dots n} b_1 b_2 \dots b_n
 \end{aligned} \tag{3.1}$$

where

$$x(b_1, b_2, \dots, b_n) \in \{x\}, x = 1, 2, \dots, M \text{ and } d_i, d_{ij}, d_{ijh}, \dots$$

are the coefficients that we want to find, and  $b_i, b_j, b_n \in \{-1, 1\}$ .

Following the discussion in [Ref. 4], we note that there are

$$\binom{n}{0} + \binom{n}{1} + \binom{n}{2} + \dots + \binom{n}{n} = 2^n \quad (3.2)$$

coefficients. Let  $x$  denote a column vector with  $2^n$  elements which are all the values that  $x$  can assume. Also, let  $d$  denote a column vector whose elements are the unknown coefficients. Let  $B$  be a  $2^n \times 2^n$  matrix where each row represents the  $2^n$  values taken by all the products of  $b_i$ 's in (3.1). Thus, (3.1) may be written in matrix form as follows:

$$x = Bd \quad (3.3)$$

where

$$x = \begin{bmatrix} x(1, 1, 1, \dots, 1) \\ x(-1, 1, 1, \dots, 1) \\ \vdots \\ x(-1, -1, -1, \dots, -1) \end{bmatrix}_{2^n \times 1}$$

and

$$B_k = [1 \ b_1 \ b_2 \ b_{12} \ \dots \ b_{12} \ \dots \ 1]$$

is the  $k^{\text{th}}$  row of  $2^n \times 2^n$  matrix  $B$ . Also,

$$d^T = [d_0 \ d_1 \ d_2 \ d_{12} \ \dots \ d_{12} \ \dots \ 1]$$

where the superscript  $T$  denotes matrix transpose. We note that  $B$  is a  $2^n \times 2^n$  square matrix and  $B = B^T$ , hence  $B$  is symmetric. In other words, it is an orthogonal matrix [Ref. 4]. Therefore:

$$BB^T = 2^n I \quad (3.4)$$

where  $I$  is  $2^n \times 2^n$  identity matrix. Thus,

$$B^{-1} = \frac{1}{2^n} B^T \quad (3.5)$$

and the solution of (3.3) is

$$d = \frac{1}{2^n} B^T x \quad (3.6)$$

A computer program listing is given in Appendix B to calculate the coefficients in  $d$ . The program requires the number of inputs  $k$ , the constraint length  $v$ , and the vector  $x$ . The elements of  $x$  are from the set  $\{x\}$ ,  $x=1, 2, \dots, M$ . Thus,  $x$  is the signal assignment of the corresponding trellis diagram.

Once the relation between the input stream  $\{b_i\}$  and  $\{x\}$ ,  $x=1, 2, \dots, M$  is known, the encoder is realized according to logic variables  $\{a_i\}$ . In other words, a natural TCM/MFSK mapper may be implemented if the analytic description of the encoder is available. In an orthogonal MFSK signal constellation, all signals have equal euclidean distance from each other as stated in (2.3). Thus, the distance is of no importance when the signals in  $x$  are assigned. Instead, care should be given to avoiding a catastrophic code (a limited number of errors causes an infinite number of errors at the Viterbi

decoder output) and intersymbol inference should be kept in mind. Another important concern may be the complexity of the encoder. If the three rules below are followed, generally one ends up with a good code:

1. All elements of  $x$  should be equiprobable.
2. The first  $2^m$  elements must consist of the elements of  $x=1, 2, \dots, M$ .
3. The frequency differences must be kept constant giving the maximum signal difference to  $b_1$ .

These rules are derived from a computer search of many signal assignments. Rule 1 ensures to keep the optimality of decoding which is maximum-likelihood and optimal for the equally likely messages. All three rules are also intended to avoid catastrophic conditions and reduce Doppler interference. If we end up with a consistent mapping rule, this ensures that TCM/MFSK is not catastrophic. Rule 3, with the other two rules, guarantees that adjacent transitions have the maximum frequency separation which reduces Doppler interference.

A frequency difference corresponds to the absolute difference between any two elements of  $\{x\}$ ,  $x=1, 2, \dots, M$  whose associated trellis transitions differ only one bit. For example, the frequency difference due to  $b_j$  is

$$\delta_j = |x(b_1, b_2, \dots, b_j, \dots, b_{k+v}) - x(b_1, b_2, \dots, -b_j, \dots, b_{k+v})| \quad (3.7)$$

When all  $\delta_j$ 's  $j=1, 2, \dots, n$  are kept constant,  $d$  has a minimum number of nonzero elements and transmitter complexity is minimal [Ref.6].

A list of the codes for TCM/4-FSK and TCM/8-FSK with several constraint lengths is given at the end of this chapter. In signal assignment for 4-ary codes, the frequency differences are kept constant in a periodic fashion, as follows:

$$\delta_1 = 2, \delta_2 = 1, \delta_3 = 2, \delta_4 = 1 \dots \dots \quad (3.8)$$

On the other hand, for 8-ary codes, the following frequency differences are used.

$$\{\delta_i, i = 1, 2, \dots 10\} = \{4, 2, 1, 4, 2, 1, 4, 2, 2, 4\} \quad (3.9)$$

For TCM/8-FSK,  $k$  is 2 and the codes with constraint length  $v$  up to 8 are considered. Hence, the maximum  $n = 2 + 8 = 10$ . Because the channel waveform depends on  $n = k + v$  bits, TCM/8-FSK waveforms with  $v = 8$  will be a function of 10 bits. If the constraint length  $v$  is taken to be 2, TCM/8-FSK waveforms are determined by  $n = k + v = 4$  bits. Thus, only  $\delta_1, \delta_2, \delta_3$  and  $\delta_4$  will be considered.

Once we have an analytic expression for the code we may find the natural mapping rule in terms of the logic variables  $a_i, a_i \in \{0,1\}$ . We note that  $a_i = \frac{1}{2}(1-b_i)$  and that multiplication with  $b_i$  variables corresponds to an *exclusive or* function in logic variables  $a_i$ . The natural mapping is the process of mapping the output of the convolutional encoder to one of the  $M$  signals according to a given rule. For example, Gray encoding is a kind of mapping with the rule that adjacent signals have a change of only one bit. The natural mapping is defined in logical terms, not in physical quantities; hence, the constants in analytic expression have no meaning in the natural mapping.

The codes in logic variables corresponding to analytic expressions in Table 3.3 are listed in Table 3.4. The variables  $\{z_j\}, j = 1, 2, \dots m$  are the inputs to the natural

frequency mapper. (Obviously,  $z_j$ 's can also be viewed as the outputs of the convolutional encoder.) The mapping rules for TCM/4-FSK and TCM/8-FSK are found by examining the signal assignment of each scheme and are given in Table 3.1 and Table 3.2, respectively.

**TABLE 3.1 TCM/4-FSK NATURAL MAPPING RULE**

$Z_1$	$Z_2$	Frequency Slot
0	0	1
0	1	2
1	0	3
1	1	4

The analytic expression and consequently the natural mapping rule is a function of signal assignment. Thus it is possible to find other codes by changing the signal assignment within the rules given previously. In other words, the code for a given constraint length, code rate, and modulation is not unique.

**TABLE 3.2 TCM/8-FSK NATURAL MAPPING RULE**

$Z_1$	$Z_2$	$Z_3$	Frequency Slot
0	0	0	1
0	0	1	2
0	1	0	3
0	1	1	4
1	0	0	5
1	0	1	6
1	1	0	7
1	1	1	8

**TABLE 3.3 ANALYTIC DESCRIPTIONS OF THE CODES**

Code Rate (r)	TCM/MFSK	Constraint Length (v)	Analytic Description
1/2	4-ary	2	$x=2.5-0.5b_2-b_1b_3$
1/2	4-ary	3	$x=2.5-0.5b_2b_4-b_1b_3$
1/2	4-ary	4	$x=2.5-0.5b_2b_4-b_1b_3b_5$
1/2	4-ary	5	$x=2.5-0.5b_2b_4b_6-b_1b_3b_5$
1/2	4-ary	6	$x=2.5-0.5b_2b_4b_6-b_1b_3b_5b_7$
1/2	4-ary	7	$x=2.5-0.5b_2b_4b_6b_8-b_1b_3b_5b_7$
2/3	8-ary	2	$x=4.5-0.5b_3-b_2-2b_1b_4$
2/3	8-ary	3	$x=4.5-0.5b_3-b_2b_5-2b_1b_4$
2/3	8-ary	4	$x=4.5-0.5b_3b_6-b_2b_5-2b_1b_4$
2/3	8-ary	5	$x=4.5-0.5b_3b_6-b_2b_5-2b_1b_4b_7$
2/3	8-ary	6	$x=4.5-0.5b_3b_6-b_2b_5b_8-2b_1b_4b_7$
2/3	8-ary	7	$x=4.5-0.5b_3b_6b_9-b_2b_5b_8-2b_1b_4b_7$
2/3	8-ary	8	$x=4.5-0.5b_3b_6b_9-b_2b_5b_8-2b_1b_4b_7b_{10}$

**TABLE 3.4 CODES IN LOGIC VARIABLES**

Code Rate (r)	TCM/MFSK	Constraint Length	$Z_1$	$Z_2$	$Z_3$
1/2	4-ary	2	$a_1 \oplus a_3$	$a_2$	-
1/2	4-ary	3	$a_1 \oplus a_3$	$a_2 \oplus a_4$	-
1/2	4-ary	4	$a_1 \oplus a_3 \oplus a_5$	$a_2 \oplus a_4$	-
1/2	4-ary	5	$a_1 \oplus a_3 \oplus a_5$	$a_2 \oplus a_4 \oplus a_6$	-
1/2	4-ary	6	$a_1 \oplus a_3 \oplus a_5 \oplus a_7$	$a_2 \oplus a_4 \oplus a_6$	-
1/2	4-ary	7	$a_1 \oplus a_3 \oplus a_5 \oplus a_7$	$a_2 \oplus a_4 \oplus a_6 \oplus a_8$	-
2/3	8-ary	2	$a_1 \oplus a_4$	$a_2$	$a_3$
2/3	8-ary	3	$a_1 \oplus a_4$	$a_2 \oplus a_5$	$a_3$
2/3	8-ary	4	$a_1 \oplus a_4$	$a_2 \oplus a_5$	$a_3 \oplus a_6$
2/3	8-ary	5	$a_1 \oplus a_4 \oplus a_7$	$a_2 \oplus a_5$	$a_3 \oplus a_6$
2/3	8-ary	6	$a_1 \oplus a_4 \oplus a_7$	$a_2 \oplus a_5 \oplus a_8$	$a_3 \oplus a_6$
2/3	8-ary	7	$a_1 \oplus a_4 \oplus a_7$	$a_2 \oplus a_5 \oplus a_8$	$a_3 \oplus a_6 \oplus a_9$
2/3	8-ary	8	$a_1 \oplus a_4 \oplus a_7 \oplus a_{10}$	$a_2 \oplus a_5 \oplus a_8$	$a_3 \oplus a_6 \oplus a_9$

$\oplus$  denotes exclusive or

## IV. ENCODER DESIGN EXAMPLES

### A. ENCODER DESIGN 1

In this example, a rate  $\frac{1}{2}$  TCM/4-FSK encoder is considered. The constraint length  $v$  is chosen to be 3. There are  $v = 3$  memory elements and  $2^v = 8$  trellis states, each having  $2^k = 2$  transitions. Normalized squared free Euclidean distance is found by using the program in Appendix A, which is 4. The input to this program is the matrix  $N$ . The trellis structure, signal assignment, matrix  $N$ , and input/state variables are shown in Figure 4.1.

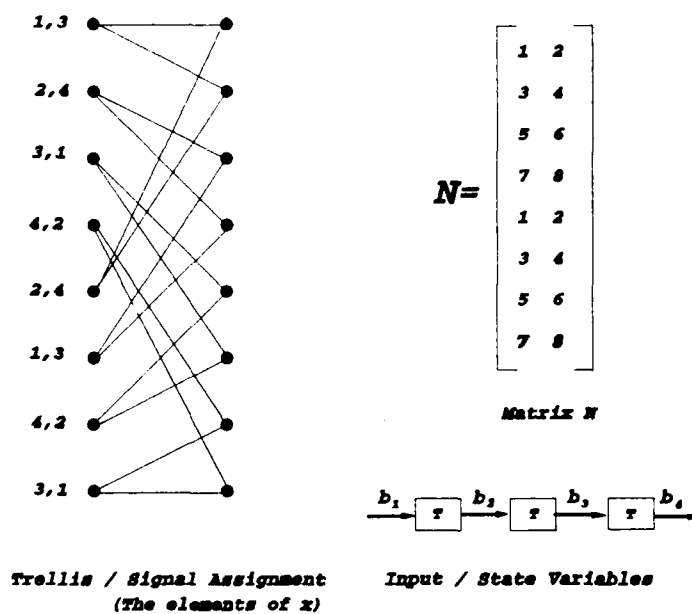

Figure 4.1

The rows of  $N$  are the labels of the destination states, respectively. For example, the first state has transitions to state 1 and state 2; hence, the first row of  $N$  has the labels 1 and 2. The second state has transitions to state 3 and state 4, and the elements of the second row are 3 and 4 and so on.

The signal assignment is made by keeping the frequency differences constant; hence,

$$\delta_1 = 2, \delta_2 = 1, \delta_3 = 2, \delta_4 = 1$$

For example, the transition from state 1 to state 1 occurs when the first frequency is transmitted. If the third frequency is transmitted then the new encoder state is the second one. The definition of frequency difference is stated in (3.7). The adjacent transitions are different in the  $b_1$  bit only, thus the frequency difference  $\delta_1$  due to  $b_1$  is 2. The signal assignment in Figure 4.1 is put in vector form as:

$$\mathbf{x} = [1 \ 3 \ 2 \ 4 \ 3 \ 1 \ 4 \ 2 \ 2 \ 4 \ 1 \ 3 \ 4 \ 2 \ 3 \ 1]$$

The input of the program given in Appendix B is the  $\mathbf{x}$  vector. The program also requires the number of inputs  $k$  and the constraint length  $v$ . The outputs of this program are the coefficients in  $\mathbf{d}$  which are found to be:

$$d_0 = 2.5$$

$$d_{13} = -1$$

$$d_{24} = -0.5$$

Thus, from (3.3) the analytic description of the code is

$$x = 2.5 - b_1 b_3 - 0.5 b_2 b_4$$

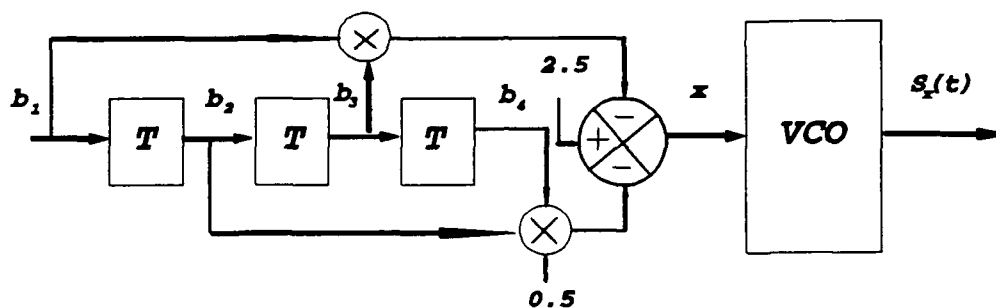

Figure 4.2 Analytic Description Transmitter for TCM/4-FSK, 8 States

The analytic description of the transmitter may be implemented as in Figure 4.2. The natural mapper implementation in terms of the logic variables  $a_i$  is as follows. If we make the change of variables

$$x = 2.5 - y_1 - 0.5 y_2$$

where  $y_1 = b_1 b_3$  and  $y_2 = b_2 b_4$ , then since the multiplication in  $b_i$  corresponds to an exclusive-or function in logic variables, we can find the new variables as

$$\begin{aligned} z_1 &= a_1 \oplus a_3 \\ z_2 &= a_2 \oplus a_4 \end{aligned}$$

These new variables  $z_1, z_2$  are input to the natural mapper. The mapping rule is found by examining the signal assignment. Thus, the natural mapper implementation may be as in Figure 4.3 with the following mapping rule.

TABLE 4.1

$z_1$	$z_2$	Frequency
0	0	1
0	1	2
1	0	3
1	1	4

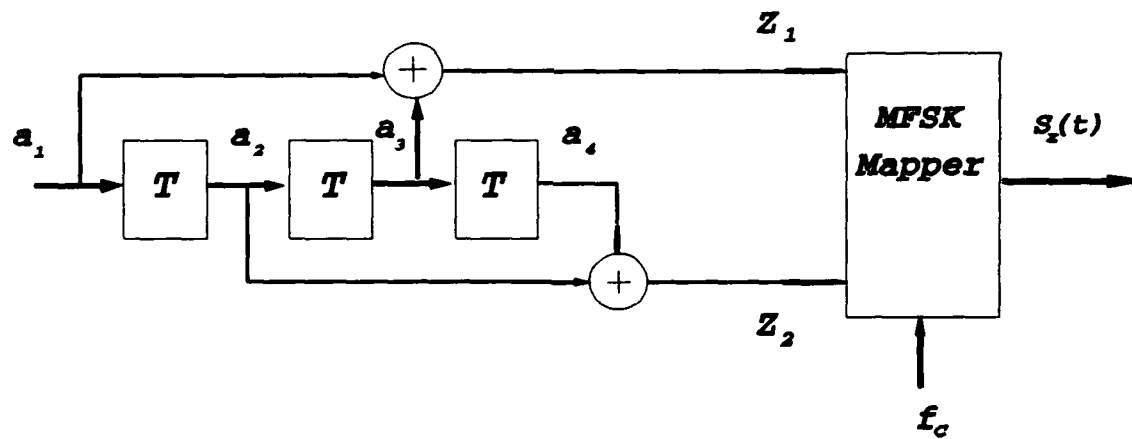

Figure 4.3 Natural Mapper for  $r = 1/2, v = 3, \text{TCM/4-FSK}$

The bandwidth efficiency of rate  $\frac{1}{2}$  TCM/4-FSK scheme can be found from (2.7)

as

$$\frac{k}{2^m} = \frac{1}{4} \text{ b/s/Hz}$$

Uncoded 16-FSK has the same bandwidth efficiency. The ACG is 0 dB with respect to uncoded 16-FSK (Table 2.1).

## B. ENCODER DESIGN 2

A rate  $\frac{2}{3}$  TCM/8-FSK with constraint length  $v = 4$  is introduced in this example. There are 4 memory bits and  $2^v = 16$  trellis states. The number of transitions at each state is  $2^k = 4$ . The squared free euclidean distance is found to be 3. The trellis diagram, signal assignment, matrix  $N$ , and input/state variables are shown in Figure 4.4.

The bandwidth efficiency of the rate  $\frac{2}{3}$  TCM/8-FSK encoder is (2.7)

$$\frac{k}{2^m} = \frac{1}{4} \text{ b/s/Hz}$$

Uncoded 16-FSK has the same bandwidth efficiency. The ACG with respect to uncoded 16-FSK is 1.76 dB (Table 2.1).

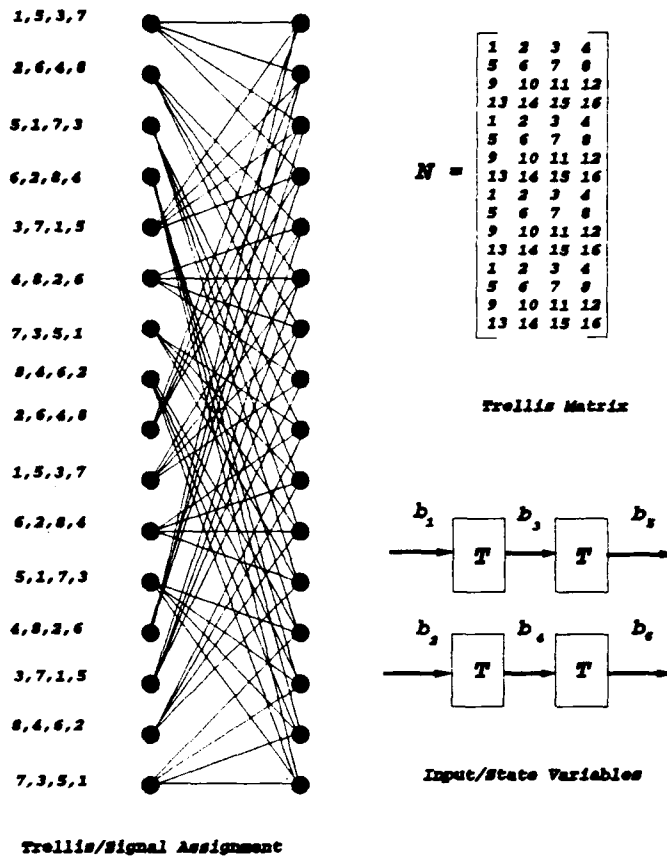

Figure 4.4

When the signal assignment in Figure 4.4 is put in a vector  $x$  as

$$x = \begin{bmatrix} 1537264851736284 \\ 3715482673518462 \\ 2648153762845173 \\ 4826371584627351 \end{bmatrix}$$

and input to the program in Appendix B, the  $d$  coefficients are found to be

$$d_0 = 4.5$$

$$d_{14} = -2$$

$$d_{25} = -1$$

$$d_{36} = -0.5$$

Hence, the analytical description of the set  $\{x\}$ ,  $x = 1, 2, \dots, 8$  in terms of  $b_i$  is

$$x = 4.5 - 2b_1b_4 - b_2b_5 - 0.5b_3b_6$$

The above equation may be written as

$$x = 4.5 - 2y_1 - y_2 - 0.5y_3$$

where

$$y_1 = b_1b_4$$

$$y_2 = b_2b_5$$

$$y_3 = b_3b_6$$

Therefore,  $z_i$  variables in terms of  $a_i$  are

$$z_1 = a_1 \oplus a_4$$

$$z_2 = a_2 \oplus a_5$$

$$z_3 = a_3 \oplus a_6$$

with the following mapping rule (Table 4.2). The natural mapper implementation of rate  $2/3$  TCM/8-FSK with 16 states is shown in Figure 4.5.

TABLE 4.2

$z_3$	$z_2$	$z_1$	Frequency
0	0	0	1
1	0	0	2
0	1	0	3
1	1	0	4
0	0	1	5
1	0	1	6
0	1	1	7
1	1	1	8

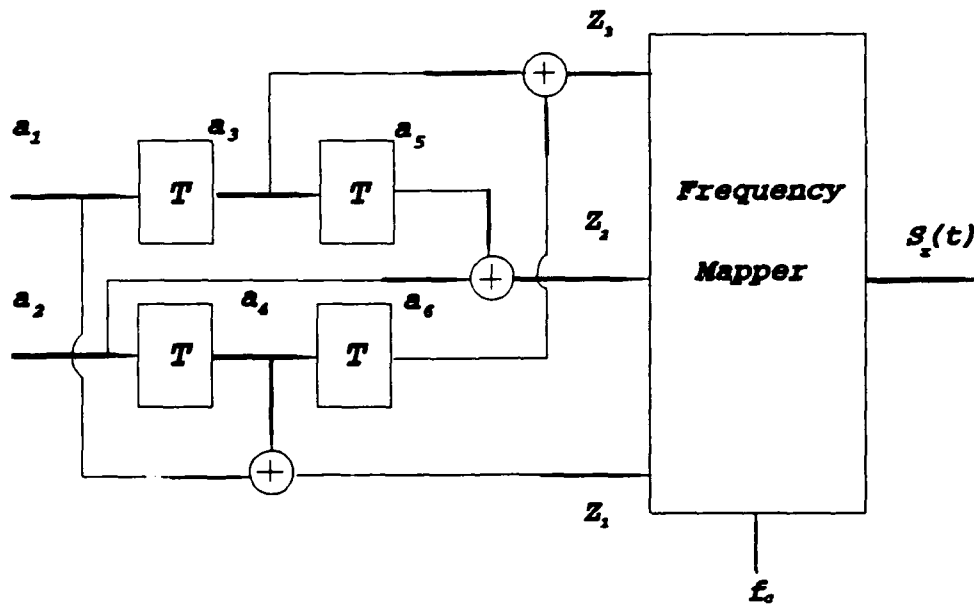

Figure 4.5 Natural Frequency Mapper for  $r = 2/3$ ,  $v = 4$ , TCM/8-FSK

### C. ENCODER DESIGN 3

A rate  $\frac{1}{2}$  TCM/4-FSK encoder with 32 states is considered. The constraint length is  $v = \log_2 32 = 5$ . Each state has 2 transitions. The squared free Euclidean distance is 6; ACG with respect to uncoded 16-FSK is 1.7 dB (Table 2.1). The matrix N which is the definition of the trellis diagram is given in (4.1) (following page).

The signal assignment keeps the following frequency differences constant

$$\delta_1 = 2, \delta_2 = 1, \delta_3 = 2, \delta_4 = 1, \delta_5 = 2, \delta_6 = 1$$

The vector  $x$  is

$$x = \begin{bmatrix} 1 & 3 & 2 & 4 & 1 & 4 & 2 & 2 & 4 & 1 & 3 & 4 & 2 & 3 & 1 & 3 & 1 & 4 & 2 & 1 & 3 & 2 & 4 \\ 4 & 2 & 3 & 1 & 2 & 4 & 1 & 3 & 2 & 4 & 1 & 3 & 4 & 2 & 3 & 1 & 1 & 3 & 2 & 4 & 3 & 1 & 4 & 2 \\ 4 & 2 & 3 & 1 & 2 & 4 & 1 & 3 & 3 & 1 & 4 & 2 & 1 & 3 & 2 & 4 & & & & & & & & \end{bmatrix}$$

The above signal assignment yields the following analytic expression

$$x = 2.5 - b_2 b_4 b_6 - b_1 b_3 b_5$$

and the  $z_i$  variables are

$$z_1 = a_1 \oplus a_3 \oplus a_5$$

$$z_2 = a_2 \oplus a_4 \oplus a_6$$

with the mapping rule given in Table 3.1. The natural mapper implementation is shown in Figure 4.6.

$$N = \begin{bmatrix} 1 & 2 \\ 3 & 4 \\ 5 & 6 \\ 7 & 8 \\ 9 & 10 \\ 11 & 12 \\ 13 & 14 \\ 15 & 16 \\ 17 & 18 \\ 19 & 20 \\ 21 & 22 \\ 23 & 24 \\ 25 & 26 \\ 27 & 28 \\ 29 & 30 \\ 31 & 32 \\ 1 & 2 \\ 3 & 4 \\ 5 & 6 \\ 7 & 8 \\ 9 & 10 \\ 11 & 12 \\ 13 & 14 \\ 15 & 16 \\ 17 & 18 \\ 19 & 20 \\ 21 & 22 \\ 23 & 24 \\ 25 & 26 \\ 27 & 28 \\ 29 & 30 \\ 31 & 32 \end{bmatrix} \tag{4.1}$$

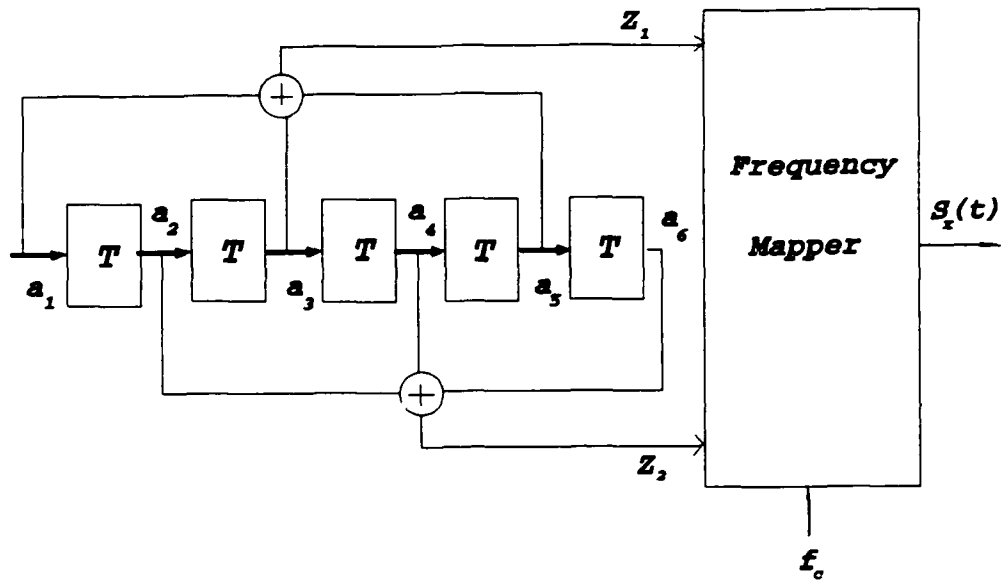

Figure 4.6 Natural Frequency Mapper rate =  $\frac{1}{2}$ ,  $v = 5$ , TCM/4-FSK

#### D. ENCODER DESIGN 4

A TCM/8-FSK encoder with 32 states is given to make the subject clearer. The rate is  $r = \frac{2}{3}$ ; hence  $k = 2$ ,  $m = 3$ . The constraint length  $v$  is 5 and ACG is 1.76 dB.

The matrix  $N$  is given in (4.2).

$$N = \begin{bmatrix}
 1 & 2 & 3 & 4 \\
 5 & 6 & 7 & 8 \\
 9 & 10 & 11 & 12 \\
 13 & 14 & 15 & 16 \\
 17 & 18 & 19 & 20 \\
 21 & 22 & 23 & 24 \\
 25 & 26 & 27 & 28 \\
 29 & 30 & 31 & 32 \\
 1 & 2 & 3 & 4 \\
 5 & 6 & 7 & 8 \\
 9 & 10 & 11 & 12 \\
 13 & 14 & 15 & 16 \\
 17 & 18 & 19 & 20 \\
 21 & 22 & 23 & 24 \\
 25 & 26 & 27 & 28 \\
 29 & 30 & 31 & 32 \\
 1 & 2 & 3 & 4 \\
 5 & 6 & 7 & 8 \\
 9 & 10 & 11 & 12 \\
 13 & 14 & 15 & 16 \\
 17 & 18 & 19 & 20 \\
 21 & 22 & 23 & 24 \\
 25 & 26 & 27 & 28 \\
 29 & 30 & 31 & 32
 \end{bmatrix} \tag{4.2}$$

In this frequency assignment the following differences are kept constant (3.9)

$$\delta_1=4, \delta_2=2, \delta_3=1, \delta_4=4, \delta_5=2, \delta_6=1, \delta_7=4$$

These constraints yield the following  $x$  vector.

$$\begin{aligned}
 & [ 1 5 3 7 2 6 4 8 5 1 7 3 6 2 8 4 3 7 1 5 \\
 & \quad 4 8 2 6 7 3 5 1 8 4 6 2 2 6 4 8 1 5 3 7 \\
 & \quad 6 2 8 4 5 1 7 3 4 8 2 6 3 7 1 5 8 4 6 2 \\
 x = & \quad 7 3 5 1 5 1 7 3 6 2 8 4 1 5 3 7 2 6 4 8 \\
 & \quad 7 3 5 1 8 4 6 2 3 7 1 5 4 8 2 6 6 2 8 4 \\
 & \quad 5 1 7 3 2 6 4 8 1 5 3 7 8 4 6 2 7 3 5 1 \\
 & \quad 4 8 2 6 3 7 1 5 ]
 \end{aligned}$$

The  $x$  vector has  $2^{v+k} = 128$  elements. The following analytic expression is obtained by the signal assignment above

$$x = 4.5 - 0.5b_3b_6 - b_7b_5 - 2b_1b_4b_7$$

This analytic expression corresponds the following  $z_i$  variables with the rule given in Table 3.2

$$z_1 = a_1 \oplus a_4 \oplus a_7$$

$$z_2 = a_2 \oplus a_5$$

$$z_3 = a_3 \oplus a_6$$

Finally, the natural mapper can be implemented as shown in Figure 4.7.

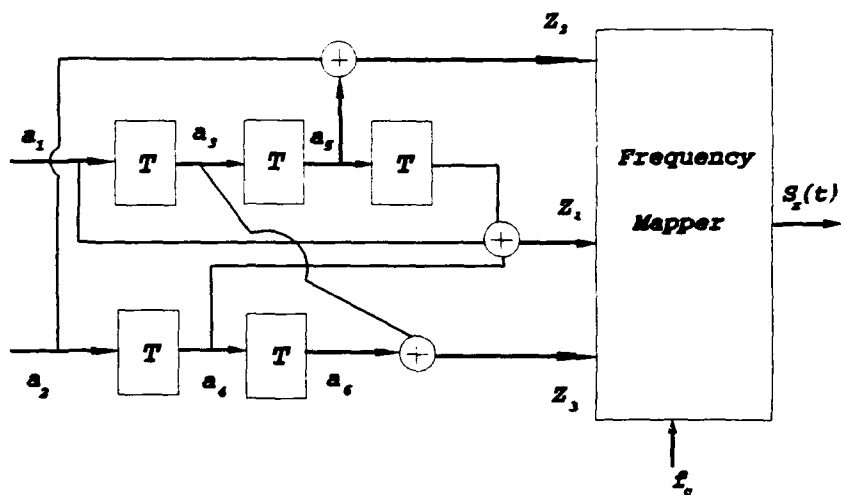

Figure 4.7 Natural Frequency Mapper,  $r = 2/3$ ,  $v = 5$ , TCM/8-FSK

## V. DISCUSSION AND CONCLUSIONS

The objective of this thesis was to investigate trellis coding of M-ary orthogonal signals. The power efficiency of this class of signaling is attractive to many communication systems when the environment is power-limited. An example of such an environment is the generation of low probability of intercept (LPI) signals. MFSK is used as an example of orthogonal signaling, but the discussion holds for other orthogonal signalings such as Pulse Position Modulation (PPM).

A method of encoding orthogonal signals by using a smaller constellation with convolutional coding for a given bandwidth efficiency was considered. The free Euclidean distance of TCM/MFSK codes plays an important role when maximum-likelihood Viterbi soft-decision decoding is used on an AWGN channel. A computer program has been written to find the free Euclidean distance. A computer search of rate  $\frac{1}{2}$  TCM/4-FSK and rate  $\frac{2}{3}$  TCM/8-FSK shows that the normalized squared free Euclidean distance increases linearly with the constraint length, as;

$$\frac{d_{free}^2}{2E} = \left\lfloor \frac{v}{k} \right\rfloor + 1$$

where  $v$  is the constraint length,  $k$  is the number of input bits, and  $\lfloor \bullet \rfloor$  is the "floor" operation (the integer part). The normalized distance between any pair of signal points is taken to be unity; i.e.,

$$d_{ij} = \sqrt{2E} = 1 \quad \text{for all } i, j \quad (i \neq j)$$

The investigation shows that an arbitrarily small error rate can be achieved with a TCM/MFSK scheme by using a larger  $v$ .

ACG comparisons are made with respect to uncoded 16-FSK having the same bandwidth efficiency. ACGs of 4.39 dB and 4.77 dB for TCM/4-FSK and TCM/8-FSK with constraint length 10 are observed, respectively. This means TCM/MFSK can maintain better performance while using the same bandwidth than uncoded MFSK.

Convolutional coding with rates  $k/m$  are proposed to be used as the underlying code. This choice brings several advantages. First, efficient soft-decision Viterbi decoders can be used. Second, since rate  $k/m$  convolutional codes are used, the signal space is expanded as much as  $2^m/2^k$  in terms of convolutional encoder input-output relations. It is shown that more coding gain is achievable with this method than the conventional approach. Doubling the signal space provides the greatest coding gain while requiring a minimum increase in system complexity [Ref. 7]. Finally, an outer coding structure may be used for further improvements in system performance.

A computer program was written to find the analytic description of the codes. Once the analytic description is known, the natural mapper implementation is straightforward. The basic rules of frequency assignment for minimal transmitter complexity were discussed. The key is to keep the frequency differences constant. It is possible to find different codes by changing the signal assignment only. Encoder design examples are worked out which are also significant as another way of convolutional code design.

Although ACG gives an idea about the performance on an AWGN channel, the actual coding gain of trellis coded orthogonal signaling on both AWGN channels and fading channels for both coherent and noncoherent demodulation is required to complete our understanding of the performance that can be expected from this type of system under realistic conditions.

## APPENDIX A

\*\*\*\*\* PROGRAM DISTANCE \*\*\*\*\*

```
*****
%
%
% This program is written in Matlab to find the free distance of a
% trellis. The transitions from each state are saved in a matrix N.
% This matrix is saved in a filename.m file.
% The first row of the matrix N consists of the #'s of the states which
% can be reached from state 1 in 1 transition. And the second row is for
% the second state... (The first state is 1, not 0). The program takes care
% of the rest. The parallel transitions are not considered. The program asks
% the name of the input file. The output of the program is the squared
% free euclidean distance of the trellis described by the matrix N
%
%
*****
clear;

% Input initialization
r=input('Enter the input file name      ','s');
N=eval(r);

% s : # of the states
% t : # of the transitions at each state
[s,t]=size(N);

% Initialization of the state transition matrix
B=zeros(s,s);
for i=1:s
    for j=1:t
        z=N(i,j);
        B(i,z)=z;
    end
end
for i=1:s
    for j=1:s
        if j==B(i,j)
            B(i,j)=1;
        else
            B(i,j)=100;
        end;
    end;
end;

% Calculation of the shortest distances
for k=1:s
    for i=1:s
        if B(i,k)~=100
            for j=1:s
                length=B(i,k)+B(k,j);
            end;
        end;
    end;
end;
```

```

        if length<B(i,j)
            B(i,j)=length;
        end;
    end;
end;
end;
end;
end;

% Calculation of the free distance w.r.t. all zero codeword
for j=1:s
    if B(1,j)==1
        DF(1,j)=B(j,1)+B(1,j);
        DF(1,1)=100;
    else
        DF(1,j)=100;
    end
end
end

% Squarred free distance
d2free=min(DF)

% Pairwise Comparision for Checking
% If the result of the pairwise comparision does not
% agree the trellis setup is wrong
dfree=100;
yeni=B;
for i=1:s
    if B(i,i)==1
        yeni(i,i)=100;
        for j=1:s
            free=yeni(i,j)+yeni(j,i);
            if free<dfree
                dfree=free;
            end
        end
    end
end
end
for i=1:s
    for j=1:s
        if yeni(i,j)==1
            yeni(i,j)=100;
            for x=1:s
                if yeni(i,x)==1
                    for k=1:s
                        if B(j,k)==B(x,k)
                            free=B(j,k)+1;
                            if free<dfree
                                dfree=free;
                            end
                        end
                    end
                end
            end
        end
    end
end
end
end
end
end
end
dfree

```

## APPENDIX B

\*\*\*\*\* PROGRAM CODE \*\*\*\*\*

```
*****
%
% This program finds the coefficients for the analytic description of a
% TCM/MFSK scheme. The inputs to the program are the # of the inputs k,
% the constraint length v, and a file. The input file contains a vector X
% which is the signal assignment of the trellis. The number of the
% elements is equal to the total number of the transitions.
%
*****
clear

% Input initialization

m=input('Enter the number of input bits ','s');
r=input('Enter the constraint length ','s');
t=input('Enter the name of the input file ','s');

% k : # of the input bits
% v : the constraint length
% X : the signal vector
% n : # of input bits plus the number of the memory bits

k=eval(m);
v=eval(r);
X=eval(t);
n=k+v;

% Creating Hadamard matrix

B=hadamard(n);

% Calculating coefficients

D=B'*X'/2^n;

% Determining the place of the coefficients

d=find(D')
```

## LIST OF REFERENCE

1. Proakis, John G., *Digital Communications*, pp. 441-506, McGraw-Hill, New York, 1989.
2. Blahut, Richard E., *Digital Transmission of Information*, pp. 263-286, Addison-Wesley, Menlo Park, 1990.
3. Derek, Trumpis B., *Convolutional Coding for M-ary Channels*, Ph.D. Dissertation, U.C.L.A., 1975.
4. Biglier, Ezio, et. al., *Introduction to Trellis-Coded Modulation with Applications*, pp. 67-97, Macmillan, New York, 1991.
5. Calderbank, Robert, and Mazo, James E., "A New Description of Trellis Codes," *IEEE Trans. on Information Theory*, Vol. IT-30, No. 6, pp. 784-791, 1984.
6. Turgeon, J. Martin, and Mclane, Peter J., "Minimal Transmitter Complexity Design of Analytically Described Trellis Codes," *IEEE Trans. on Communications*, Vol. 38, No. 9, pp. 1352-1358, 1990.
7. Garrabrant, Gary and Ehrenberg, John, "Trellis Coded Modulation Applied to Noncoherent Detection of Orthogonal Signals." MILCOM 89, 1989, pp.46.5.1-46.5.5.

## INITIAL DISTRIBUTION LIST

1. Defense Technical Information Center 2  
Cameron Station  
Alexandria, VA 22304-6145
2. Library, Code 52 2  
Naval Postgraduate School  
Monterey, CA 93943-5100
3. Chairman, Code EC 1  
Department of Electrical and Computer Engineering  
Naval Postgraduate School  
Monterey, CA 93943-5000
4. Professor Tri T. Ha, Code EC/Ha 2  
Department of Electrical and Computer Engineering  
Naval Postgraduate School  
Monterey, CA 93943-5000
5. Professor R. Clark Robertson, Code EC/Rc 1  
Department of Electrical and Computer Engineering  
Naval Postgraduate School  
Monterey, CA 93943-5000
6. Deniz Kuvvetleri Komutanligi 1  
Personel Egitim Daire Baskanligi  
Ankara, TURKEY
7. Deniz Harp Okulu Komutanligi 2  
Tuzla - Istanbul, TURKEY
8. Golcuk Tersanesi Komutanligi 2  
Golcuk - Kocaeli, TURKEY
9. Taskizak Tersanesi Komutanligi 2  
Kasimpasa - Istanbul, TURKEY