

AD-A257 776



①

Final Report on SSA.

STRUCTURED ANALYSIS

LSA TASK 302

SUPPORT SYSTEM ALTERNATIVES

LSA SUBTASK 302.2.2 & 302.2.1

**ALTERNATIVE SUPPORT CONCEPTS & UPDATE
SYSTEM**

APJ 966-233

APJ

Accession For	
NTIS CRA&I	<input checked="" type="checkbox"/>
DTIC TAB	<input type="checkbox"/>
Unannounced	<input type="checkbox"/>
Justification	
By	
Date	
Class	
Notes	
A-1	



DTIC QUALITY INSPECTED 4

AMERICAN POWER JET CO. RIDGEFIELD N.J.

92-28777



5188

92 11 03 032

11. TITLE - continued:
Subtask 302.2.2, "Alternative Support Concept Update", (APJ 966-233).

18. SUBJECT TERMS - continued:
ENTITIES, PROCEDURES, VENTURE EVALUATION REVIEW TECHNIQUE, VERT,
PROCESS FLOWS, NEW SYSTEM/EQUIPMENT IMPACT, STRUCTURED SYSTEMS
ANALYSIS FUNDAMENTALS, SUPPORT SYSTEM ALTERNATIVES, VIABLE SUPPORT
ALTERNATIVES, ALTERNATIVE SUPPORT CONCEPT UPDATE.

FOREWORD

APJ, under contract to HQs, AMCCOM, has initiated the automation of the LSA Tasks (MIL-STD-1388-1) and the assessment of the ILS elements (AR 700-127). A major goal is to unify military and contractor approach to the performance of ILS and LSA.

Detailed to meet all requirements of ILS and LSA, the automated process will continue to provide the flexibility in selecting tasks and elements to be addressed at each life cycle stage. A major advantage of this approach is to insure that the application of each task element is consistent with prescribed Army policies and procedures.

This report is one of a series presenting the Structured Analysis of the respective LSA Tasks and ILS Elements. Structured Analysis comprises a description of the process being automated in terms which facilitate system design and subsequent programming. It is increasingly the preferred approach in both industry and Government.

This report contains the Data Flow Diagrams (DFDs) of LSA Task 302, "Support System Alternatives", LSA Subtask 302.2.1, "Viable Support Alternatives" and LSA Subtask 302.2.2, "Alternative Support Concept Update". It provides definitions of the processes, data flows, data stores, and external entities involved on each DFD (Annexes A and B). The report provides an overview of the LSA Task analysis procedures and a guide to the overall development process.

To assist managers in planning and controlling this task, Venture Evaluation Review Technique (VERT) Batch Input files are provided (Annex D). These VERT tools provide government agencies with complete packages, to give contractors, that covers both technical and managerial aspects of a task. This approach establishes a standardized form of communication and management between contractors performing the task and government personnel reviewing the task.

To view this Structured Analysis in context, Annex C provides a brief working description of Structured Systems Analysis fundamentals. The overview and certain portions of the introductory text are repeated verbatim in every report in this series so that each report is free standing.

We gratefully acknowledge comments made by the Maintenance Directorate at ARDC (Picatinny Arsenal) on the draft edition of this final submission.

TABLE OF CONTENTS

<u>TITLE</u>	<u>PAGE</u>
Purpose.....	1
Background.....	1
Scope.....	1
LSA Subtasks 302.2.1 and 302.2.2	
- Description.....	1
Approach.....	2
LSA Subtasks 302.2.1 and 302.2.2	
- Data Flow Diagrams.....	3
VERT Diagrams.....	4
ANNEX A: LSA task 302 Description	
Support System Alternatives.....	A-1
ANNEX B: LSA Subtasks 302.2.1 and 302.2.2,	
Alternative Support Concept and Update,	
Data Flow Diagrams & Data Dictionary.....	B-1
ANNEX C: Structured Systems Analysis	
- Fundamentals.....	C-1
ANNEX D: Venture Evaluation Review Technique	
(VERT) Batch Input Files.....	D-1

LIST OF FIGURES

<u>FIGURE NO.</u>	<u>TITLE</u>	<u>PAGE</u>
1	Structured Analysis and Structured Systems Design Organization.....	C-2
2	Standard DFD Symbol Definitions.....	C-6

INTRODUCTION

PURPOSE

The purpose of this report series is to present the results of the APJ efforts under Contract DAAA21-86-D-0025 for coordination with the AMCCOM Program Manager prior to in-depth programming of ILS and LSA functions and processes. LSA Task 302 "Support System Alternatives", Subtasks 302.2.1 & 302.2.2, "Viable Support Alternatives & Alternative Support Concept Update" are addressed in this report.

BACKGROUND

The Department of the Army has a requirement for management control over contractor and Government agency response to the requirements of AR 700-127, "Integrated Logistic Support", and MIL-STD-1388-1, "Logistic Support Analysis". HQs AMCCOM has initiated action to structure each of the LSA tasks, the assessment of each ILS element, the form of the results, and the detailed processes to insure consistency with current Army policies, procedures, and techniques. This approach (undertaken by AMCCOM and APJ) will insure uniformity in efforts and products, reproducibility of analyses, and a well-defined structure which can be coordinated among all participants in the logistic process to arrive at common understanding and procedures.

SCOPE

This report summarizes the results of a Structured Analysis effort relative to the identification of LSA Task 302 "Support System Alternatives", LSA Subtask 302.2.1 & 302.2.2, "Viable Support Alternatives & Alternative Support Concept Update". It presents the Data Flow Diagrams (DFDs) developed from this effort. The portions of the Data Dictionary relating to labels, names, descriptions, processes, data flows, data stores, and external entities are included in their present degree of completeness. (The Data Dictionary is a "living document" that evolves through the analysis and design process).

LSA SUBTASK 302.2.1 & 302.2.2 DESCRIPTION

LSA Subtasks 302.2.1 & 302.2.2 concerns the establishment and update of Viable Support Concept Alternatives for each system/equipment alternative identified as a potential candidate to fulfill the Acquiring Activity needs.

The goal of Subtask 302.2.1 is to provide a full range of Alternative Support Concepts for each of the system equipment alternatives which satisfy the functional requirements of each alternative design approach considered in Task 301. Furthermore, Subtask 302.2.1 provides the major inputs to Task 303, "Evaluation of Alternatives and Trade-off Analysis".

The range of Alternatives Support Concepts to be addressed in Subtask 302.2.1 shall not be limited to existing standards, but should place major emphasis on new innovative approaches that take advantage of modern technology, advanced communication and control capabilities, such that major improvements might be realized in system readiness, optimize manpower and personnel requirements, and/or reduce O&S costs.

The task definitions for the major LSA Task 302 and the LSA subtasks 302.2.1 & 302.2.2 descriptions from MIL-STD 1388-1A are included as Annex A.

APPROACH

The APJ approach to Structured Analysis of the LSA task is:

1. Scope the process defined in MIL-STD-1388-1A in the context of the other LSA tasks.
2. Review the guidance provided in AMC PAM 700-11, "Logistics Support Analysis Review Team Guide".
3. Review the applicable Data Item Descriptions (DIDs) from the Acquisition Management Systems and Data Requirements Control List (AMSDL) published by the Department of Defense.
4. Review all source documents referenced in the AMSDL as applicable to the referenced DIDs of interest.
5. Apply staff experience in logistics support analysis to assure that the intent of the task has been addressed.

Structured Analysis and preparation of Data Flow Diagrams (DFDs) was further assisted by the application of Structured Analysis software. Licensed by Index Technology Corporation, Excelerator provides for automated tracking of names, labels, descriptions, multiple levels of detail in the data flow diagrams, and industry standards in symbols and diagramming practices.

Following completion of the draft DFDs, the diagrams and data dictionary were made available to working Army

logisticians currently (or recently) directly involved in the application of the same LSA tasks in current Army development programs. Comments were solicited relative to the logic of the processes described, the scope and details of the indicated approaches, and the outputs implied by the LSA task requirements.

Draft products have been well received by the external reviewers, and requests have been made for copies of the DFDs for in-house use in organizing ILS and LSA efforts. Comments were also received that the DFDs will be a useful training tool for apprentice logisticians, since they provide an overall picture of the total task and a uniform approach to its fulfillment.

LSA SUBTASKS 301.2.1 AND 301.2.2 - DATA FLOW DIAGRAMS (DFDs)

The Data Flow Diagram is a tool that shows flow of data, i.e., data flows from sources and is processed by activities to produce intermediate or final products.

The DFD provides a useful and meaningful partitioning of a system from the viewpoint of identification and separation of all functions, actions, or processes so that each can be introduced, changed, added, or deleted with minimal disruption of the overall program, i.e., it emphasizes the underlying concept of modularity and identifiable transformations of data into actionable products.

A series of two (2) DFDs have been developed to structure the LSA Subtask 301.2.1 and one (1) for LSA Subtask 301.2.2:

1. 302.2.1 - Alternative Support System Concepts (Top Level)
2. 302.2.15A - ILS Elements for Evaluation
3. 302.2.2 - Support Concept Update.

Each DFD is keyed to the specific task (LSA, in this case) through the identification number assigned in the lower right hand box. The Alpha codes indicate the level of indenture or explosion below the top level, i.e.,:

Top Level.....LSA DFD 302.2.1
First Indenture.....LSA DFD 302.2.1.5A

Each DFD makes reference to the basic LSA task it addresses, as well as the level of indenture (explosion) of the DFD. For example, the first or top level DFD, "302.2.1 &

302.2.2", refers to the paragraph in MIL-STD-1388-1A which describes the task. One of the processes (bubbles) on the top level diagram (302.2.1) is expanded and identified as "302.2.1.5A", a second level of "302.2.1.5" (Alpha "A" indicates the second level).

Four standard symbols are used in the drawing of a DFD (see Annex C, Figure 1).

A copy of each DFD is presented in Annex B, accompanied by the Data Dictionary process elements. Each entry made in the DFDs has a corresponding entry in the Data Dictionary.

This presents only those Data Dictionary entries necessary for the coordination of the overall concept and details of the processes. To facilitate review of the diagrams, process descriptions, data flow identifications, process, external entities and data store descriptions are provided. As noted above, they will continue to evolve and be expanded in the System Design phase.

VERT DIAGRAMS

The Venture Evaluation Review Technique (VERT) was developed as a network analysis technique to facilitate management decision making. It allows systematic planning and control of programs and enables managers to find solutions to real life managerial problems. The VERT Diagrams and Batch Input Files for this task can be found in Annex D. In order to understand how these Input Files were developed, a brief discussion of the methodology used is provided. The same explanation is repeated verbatim in every report.

ANNEX A

**LSA TASK 302
SUPPORT SYSTEM ALTERNATIVES**

**LSA SUBTASKS 302.2.1 & 302.2.2
VIABLE SUPPORT ALTERNATIVES
AND
ALTERNATIVE SUPPORT CONCEPT UPDATE**

ANNEX A

LSA TASK 302 DESCRIPTION

SUPPORT SYSTEM ALTERNATIVES

302.1 PURPOSE. To establish viable support system alternatives for the new system/equipment for evaluation, trade-off analysis, and determination of the best system for development.

302.2 TASK DESCRIPTION

302.2.1 Develop and document viable alternative system level support concepts for the new system/equipment alternatives which satisfy the functional requirements of the new system/equipment within the established supportability and supportability related design constraints. Each alternative support concept shall be developed to a level of detail commensurate with the hardware, software, and operational concept development, and shall address all elements of ILS. The same support concept may be applicable to multiple new system/equipment design and operational alternatives. Support concept alternatives shall be prepared to equivalent levels of detail to the degree possible for use in the evaluation and trade-off of the alternatives. The range of support alternatives considered shall not be restricted to existing standard support concepts but shall include identification of innovative concepts which could improve system readiness, optimize manpower and personnel requirements, or reduce O&S cost. Contractor logistic support (total, in part, or on an interim basis) shall be considered in formulating alternative support concepts.

302.2.2 Update the alternative support concepts as system trade-offs are conducted and new system/equipment alternatives become better defined. Alternative support concepts shall be documented at the system and subsystem level, and shall address the supportability, cost, and readiness drivers and the unique functional requirements of the new system/equipment.

1/ Abstracted verbatim from MIL-STD-1388-1A, April 11, 1983, Pages 36-37.

ANNEX B

LSA TASK 302
SUPPORT SYSTEM ALTERNATIVES

SUBTASKS 302.2.1 & 302.2.2,
VIABLE SUPPORT CONCEPT ALTERNATIVE &
SUPPORT CONCEPT UPDATES -

DATA FLOW DIAGRAMS AND PROCESS DATA DICTIONARY

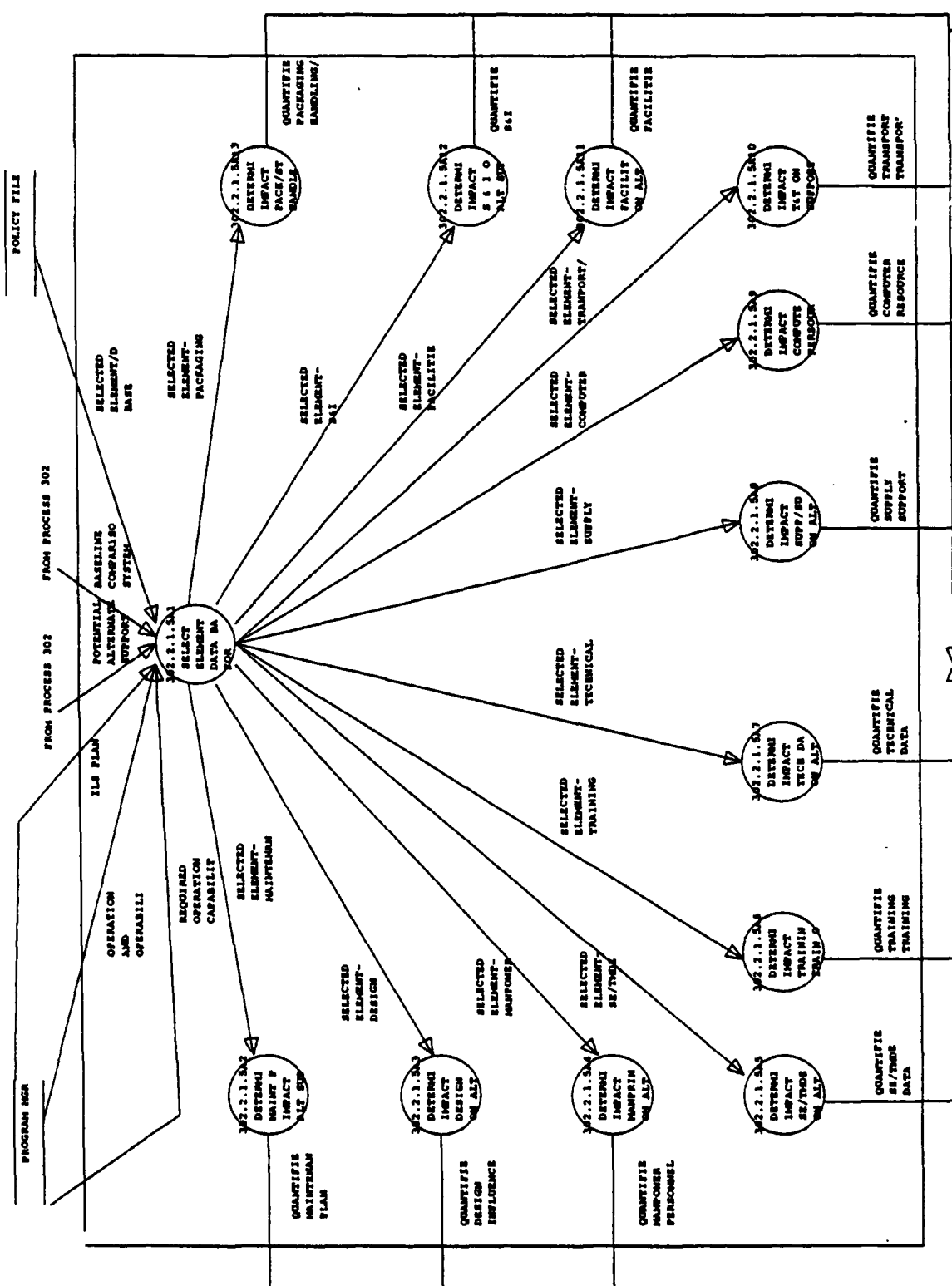

302.2.1.3A
 Created by: SID
 Revised by: SID
 Date changed: 29-AUG-89

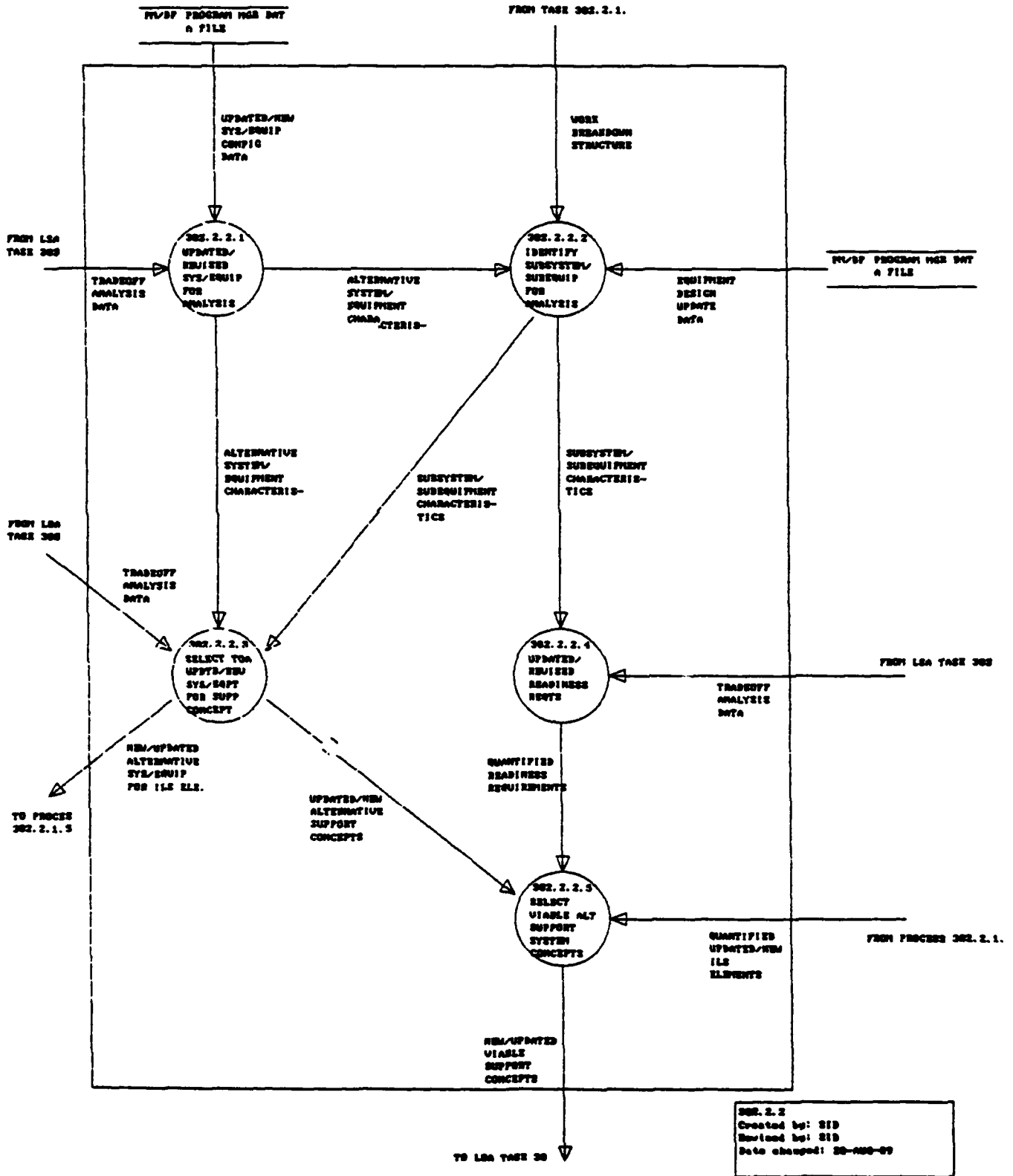

Name	Label	Description
302.2.1.1	ALT SYS/ EQUIP DATA FOR ANALYSIS	<p>IN THIS PROCESS THE PROGRAM MANAGEMENT AND ACQUIRING ACTIVITY FILE DATA REPRESENTING EACH ALTERNATIVE SYSTEM/EQUIPMENT ARE IDENTIFIED, ACCUMULATED, AND ANALYZED FOR USE IN THE DEVELOPMENT OF POTENTIAL SUPPORT CONCEPT ALTERNATIVES.</p> <p>NOTE: EACH ALTERNATIVE SYSTEM/EQUIPMENT SHALL, ON AN INDIVIDUAL BASIS, UNDERGO PROCESSING, ANALYSIS, AND DETERMINATION OF THE VIABLE ALTERNATIVE SUPPORTS IN ACCORDANCE WITH THE REQUIREMENTS OF THIS SUBTASK.</p> <p>REFERENCE: PROGRAM MANAGER'S DATA FILES ACQUIRING ACTIVITY FILES</p>
302.2.1.2	PREP ALT SYS/EQUIP BASE/COMP/ SYS DATA	<p>THIS PROCESS WILL USE THE BASELINE COMPARISON SYSTEM DATA DEVELOPED IN LSA TASK 203 TO ANALYZE THE CURRENT SYSTEM/EQUIPMENT AND ITS SUPPORT CONCEPT FOR APPLICABILITY TO THE ALTERNATIVE SYSTEM/EQUIPMENT. AN EXISTING BASELINE COMPARISON DATA DOCUMENT IS USED FOR EACH ALTERNATIVE SYSTEM/EQUIPMENT NOT HAVING SIGNIFICANT DIFFERENCES. THOSE ALTERNATIVE SYSTEM/EQUIPMENTS HAVING SIGNIFICANT DIFFERENCES WHEN COMPARED WITH THE CURRENT SYSTEM/EQUIPMENT SHALL UNDERGO COMPARATIVE ANALYSIS IN ACCORDANCE WITH LSA TASK 203.</p> <p>REFERENCE: LSA TASK 203.</p>
302.2.1.3	IDENTIFY & DEFINE ALL POTENTIAL SUPPORT SYSTEMS	<p>THIS PROCESS WILL IDENTIFY AND DEFINE ALL OF THE POTENTIAL SUPPORT CONCEPTS THAT WILL BE CONSIDERED DURING THIS TASK FOR EACH SYSTEM/EQUIPMENT ALTERNATIVE. EXAMPLES OF POTENTIAL SUPPORT CONCEPTS ARE AS FOLLOWS:</p> <ol style="list-style-type: none">1. COMPLETE CONTRACTOR SUPPORT2. INTER/INTRA SERVICE SUPPORT3. ARMY ORGANIC SUPPORT4. HOST NATION SUPPORT5. A COMBINATION OF ANY OF THE ABOVE <p>NOTE: IT SHOULD BE UNDERSTOOD THAT INTERIM CONTRACTOR SUPPORT IS NOT A SUPPORT CONCEPT, HOWEVER, IT IS A PART OF AN ACQUISITION STRATEGY.</p>
302.2.1.4	QUANTIFY READINESS REQTS	<p>THIS PROCESS WILL IDENTIFY THE READINESS CONSTRAINTS, QUANTIFY THE READINESS REQUIREMENTS FOR EACH SUPPORT CONCEPT ALTERNATIVE, AND ESTABLISH THE READINES DRIVERS.</p>
302.2.1.5	IDENT ILS ELEMENTS	<p>THIS PROCESS WILL IDENTIFY THE ILS ELEMENTS SETFORTH IN AR700-127 REQUIRING DEVELOPMENT AND INTEGRATION WITH IDENTIFIED ILS ELEMENTS FOUND TO BE FULLY DOCUMENTED AND USABLE AS IS. A TOTAL PACKAGE IS PREPARED FOR EACH POTENTIAL SUPPORT CONCEPT DEVELOPED IN PROCESS 302.2.1.3.</p> <p>REFERENCE: AR 700-127, INTEGRATED LOGISTIC SUPPORT, APPENDIX E. DA PAM 700-28, ILS PROGRAM ASSESSMENT ISSUES AND CRITERIA AMC-TRADOC PAM 70-2, MATERIAL ACQUISITION HANDBOOK, CHAPTER 12.</p>

Name	Label	Description
302.2.1.5A1	SELECT ILS ELEMENT/ DATA BASE FOR EVALUATION	THE ILS ELEMENTS TO BE SELECTED BY THIS PROCESS ARE THOSE LISTED IN AR 700-127, APPENDIX E, WHICH REQUIRE ANALYSIS AND DOCUMENTATION DEVELOPMENT. REFERENCE: AR 700-127, INTEGRATED LOGISTIC SUPPORT, APPENDIX E.
302.2.1.5A10	DETERMINE IMPACT OF T&T ON ALT SUPPORT CONCEPT	IN THIS PROCESS TRANSPORT/TRANSPORTABILITY DATA AS OUTLINED IN ARMY REGULATION 700-127 ARE DEVELOPED AND APPLIED TOWARDS THE SELECTION OF VIABLE ALTERNATIVE SUPPORT CONCEPTS. REFERENCE: AR 700-127, INTEGRATED LOGISTIC SUPPORT, APPENDIX E, PARAGRAPH E-10
302.2.1.5A11	DETERMINE IMPACT OF ON ALT SUP CONCEPT	IN THIS PROCESS FACILITIES DATA AS OUTLINED IN ARMY REGULATION 700-127 ARE DEVELOPED AND APPLIED TOWARDS THE SELECTION OF VIABLE ALTERNATIVE SUPPORT CONCEPTS. REFERENCE: AR 700-127, INTEGRATED LOGISTIC SUPPORT, APPENDIX E, PARAGRAPH E-11
302.2.1.5A12	DETERMINE IMPACT OF S & I ON ALT SUPP CONCEPT	IN THIS PROCESS STANDARDIZATION AND INTEROPERABILITY DATA AS OUTLINED IN ARMY REGULATION 700-127 ARE DEVELOPED AND APPLIED TOWARDS THE SELECTION OF VIABLE ALTERNATIVE SUPPORT CONCEPTS. REFERENCE: AR 700-127, INTEGRATED LOGISTIC SUPPORT, APPENDIX E, PARAGRAPH E-12
302.2.1.5A13	DETERMINE IMPACT OF HANDLE ON ALT SUP CO	IN THIS PROCESS PACKAGING/HANDLING/STORAGE DATA AS OUTLINED IN ARMY REGULATION 700-127 ARE DEVELOPED AND APPLIED TOWARDS THE SELECTION OF VIABLE ALTERNATIVE SUPPORT CONCEPTS. REFERENCE: AR 700-127, INTEGRATED LOGISTIC SUPPORT, APPENDIX E, PARAGRAPH E-5.1
302.2.1.5A2	DETERMINE MAINT PLAN IMPACT ON ALT SUPP CONCEPT	IN THIS PROCESS MAINTENANCE PLANNING DATA AS OUTLINED IN ARMY REGULATION 700-127 ARE DEVELOPED AND APPLIED TOWARDS THE SELECTION OF VIABLE ALTERNATIVE SUPPORT CONCEPTS. REFERENCE: AR 700-127, INTEGRATED LOGISTIC SUPPORT, APPENDIX E, PARAGRAPH E-2
302.2.1.5A3	DETERMINE IMPACT OF DESIGN INF ON ALT SUP CONCEPT	IN THIS PROCESS DESIGN INFLUENCE DATA AS OUTLINED IN ARMY REGULATION 700-127 ARE DEVELOPED AND APPLIED TOWARDS THE SELECTION OF VIABLE ALTERNATIVE SUPPORT CONCEPTS. REFERENCE: AR 700-127, INTEGRATED LOGISTIC SUPPORT, APPENDIX E, PARAGRAPH E-2

Name	Label	Description
302.2.1.5A4	DETERMINE IMPACT OF MANPRINT ON ALT SUP CONCEPT	IN THIS PROCESS MANPOWER AND PERSONNEL DATA AS OUTLINED IN ARMY REGULATION 700-127 ARE DEVELOPED AND APPLIED TOWARDS THE SELECTION OF VIABLE ALTERNATIVE SUPPORT CONCEPTS. REFERENCE: AR 700-127, INTEGRATED LOGISTIC SUPPORT, APPENDIX E, PARAGRAPH E-4
302.2.1.5A5	DETERMINE IMPACT OF SE/TMDE ON ALT SUP CONCEPT	IN THIS PROCESS SE/TMDE DATA AS OUTLINED IN ARMY REGULATION 700-127 ARE DEVELOPED AND APPLIED TOWARDS THE SELECTION OF VIABLE ALTERNATIVE SUPPORT CONCEPTS. REFERENCE: AR 700-127, INTEGRATED LOGISTIC SUPPORT, APPENDIX E, PARAGRAPH E-6
302.2.1.5A6	DETERMINE IMPACT OF TRAINING/ TRAIN ON ALT SUPP	IN THIS PROCESS TRAINING & TRAINING DEVICES DATA AS OUTLINED IN ARMY REGULATION 700-127 ARE DEVELOPED AND APPLIED TOWARDS THE SELECTION OF VIABLE ALTERNATIVE SUPPORT CONCEPTS. REFERENCE: AR 700-127, INTEGRATED LOGISTIC SUPPORT, APPENDIX E, PARAGRAPH E-7
302.2.1.5A7	DETERMINE IMPACT OF TECH DATA ON ALT SUP CONCEPT	IN THIS PROCESS TECHNICAL DATA AS OUTLINED IN ARMY REGULATION AR 700-127 ARE DEVELOPED AND APPLIED TOWARDS THE SELECTION OF VIABLE ALTERNATIVE SUPPORT CONCEPTS. REFERENCE: AR 700-127, INTEGRATED LOGISTIC SUPPORT, APPENDIX E, PARAGRAPH E-8
302.2.1.5A8	DETERMINE IMPACT OF SUPP/SUPP ON ALT SUP CONCEPT	IN THIS PROCESS SUPPLY SUPPORT DATA AS OUTLINED IN ARMY REGULATION 700-127 ARE DEVELOPED AND APPLIED TOWARDS THE SELECTION OF VIABLE ALTERNATIVE SUPPORT CONCEPTS. REFERENCE: AR 700-127, INTEGRATED LOGISTIC SUPPORT, APPENDIX E, PARAGRAPH E-5
302.2.1.5A9	DETERMINE IMPACT OF COMPUTER RERSOURCE ON ALT SUP	IN THIS PROCESS COMPUTER RESOURCE DATA OUTLINED IN ARMY REGULATION AR 700-127 ARE DEVELOPED AND APPLIED TOWARDS THE SELECTION OF VIABLE ALTERNATIVE SUPPORT CONCEPTS. REFERENCE: AR 700-127, INTEGRATED LOGISTIC SUPPORT, APPENDIX E, PARAGRAPH E-9.
302.2.1.6	SELECT VIABLE ALT SUPPORT SYSTEM CONCEPT	THE IDENTIFIED AND DOCUMENTED POTENTIAL ALTERNATIVE SUPPORT CONCEPTS IDENTIFIED IN PROCESS 302.2.1.3 ARE REVIEWED WITH A VIEW TOWARDS SELECTION OF THOSE CONCEPTS SHOWN TO BE VIABLE ALTERNATIVES FOR EACH SYSTEM/EQUIPMENT ALTERNATIVE. ALL VIABLE SUPPORT CONCEPT DOCUMENTATION ARE RETAINED FOR TRADEOFF ANALYSIS IN TASK 303.

Name	Label	Description
302.2.2.1	UPDATED/ REVISED SYS/EQUIP FOR ANALYSIS	IN THIS PROCESS, THE UPDATED OR REVISED CONFIGURATION DATA RESULTING FROM THE TRADEOFF ANALYSIS OR ENGINEERING UPDATE OR DEVELOPMENT WITH DATA LOCATED IN THE PROGRAM MANAGEMENT FILE ARE REVIEWED AND THE ALTERNATIVE SYSTEM/EQUIPMENT UNDER CONSIDERATION IS REVISED ACCORDINGLY . NOTE: EACH SYSTEM/EQUIPMENT ALTERNATIVE UPDATED OR REVISED IN THIS PROCESS SHALL, ON AN INDIVIDUAL BASIS, PROCEED THROUGH THIS TASK UNTIL COMPLETION.
302.2.2.2	IDENTIFY SUBSYSTEM/ SUBEQUIP FOR ANALYSIS	EACH UPDATED OR REVISED ALTERNATIVE SYSTEM/EQUIPMENT DEVELOPED IN PROCESS 302.2.2.1 IS REVIEWED WITH THEIR APPLICABLE WORK BREAKDOWN STRUCTURE TO IDENTIFY THE SUBSYSTEMS AND/OR SUBEQUIPMENTS (OR ASSEMBLIES) CONSTITUTING THE ALTERNATIVE. REFERENCE: MIL-STD-881A, WORK BREAKDOWN STRUCTURE
302.2.2.3	SELECT TOA UPDTD/REV SYS/EQPT FOR SUPP CONCEPT	THIS PROCESS WILL USE THE RESULTS FROM TASK 303 AND THE NEWLY REDEFINED SYSTEM/EQUIPMENT TO UPDATE THE ALTERNATIVE SUPPORT CONCEPTS. THIS PROCESS EXPLODES TO DFD 302.2.1.5A FOR THE DEVELOPMENT OF NEW, REVISED, OR UPDATED ILS ELEMENT DOCUMENTATION. THIS PROCESS WILL BE OF AN ITERATIVE PROCESS CONTINUOUS THROUGHOUT THE EQUIPMENT DEVELOPMENT PROGRAM, THAT IS, TASKS 302 AND 303 WILL BE REPEATED AS THE DESIGN PROGRESSES AND THE EQUIPMENT BECOMES BETTER DEFINED AND MORE DATA BECOMES AVAILABLE AND /OR THE DESIGN CHANGES.
302.2.2.4	UPDATED/ REVISED READINESS REQTS	THIS PROCESS WILL IDENTIFY THE UPDATED /REVISED (IF ANY) READINESS CONSTRAINTS, REQUANTIFY THE READINESS REQUIREMENTS FOR EACH SUPPORT CONCEPT ALTERNATIVE, AND REVISE THE READINESS DRIVERS.
302.2.2.5	SELECT VIABLE ALT SUPPORT SYSTEM CONCEPTS	IN THIS PROCESS THE UPDATED OR REVISED ALTERNATIVE SUPPORT CONCEPTS ARE REVIEWED AND ANALYZED. SELECTION OF THOSE CONCEPTS SHOWN TO BE VIABLE ALTERNATIVES FOR EACH UPDATED OR REVISED SYSTEM/EQUIPMENT ALTERNATIVE ARE DOCUMENTED AND RETAINED FOR TRADEOFF ANALYSIS (LSA TASK 303).

Name	Label	Description
AAF	ACQUIRING ACTIVITY FILE	CONTAINS THOSE RECORDS, DOCUMENTS, DECISION PAPERS, SCHEDULES THAT WERE PREPARED AS PART OF THE ACQUISITION INITIATION, JUSTIFICATION, AND PLANNING PRIOR TO THE ASSIGNMENT OF A PROGRAM MANAGER. THE ITEMS IN THIS DATA STORE INCLUDE: A. THREAT ANALYSIS DATA B. O&O PLAN C. READINESS OBJECTIVES DATA D. FUNTIONAL REQUIREMENTS DATA E. PROJECTED SCHEDULE DATA F. LOGISTICS RESOURCES DATA G. DESIRED R & M PARAMETERS H. TOA I. TOD J. COST & OPERATIONAL EFFECTIVENESS ANALYSIS (COEA) DATA K. PROJECTED COST DATA L. JUSTIFICATION OF MAJOR SYSTEM NEW START (JMSNS) DATA M. REQUIRED OPERATIONAL CAPABILITY (IF PREPARED PRIOR TO ASSIGNMENT OF PROGRAM MANAGER - ELSE FOUND IN PM FILES)

Name	Label	Description
P/F	POLICY FILES	<p>CONTAINS THOSE MILITARY PUBLICATIONS, DECISION PAPERS, MISSIONS & FUNCTIONS, etc, WHICH ARE NEEDED TO ESTABLISH THE LOGISTICAL SUPPORT AND REVIEW REQUIREMENTS OF THE ITEM/EQUIPMENT DEVELOPMENT PROGRAM.</p> <p>THIS DATA STORE INCLUDES:</p> <ol style="list-style-type: none">1. AR 12-16, "MUTUAL LOGISTICS SUPPORT BETWEEN THE U.S. AND OTHER NORTH ATLANTIC TREATY ORGANIZATION FORCES"1a. AR 70-1, "SYSTEMS ACQUISITION POLICY AND PROCEDURES"1b. AR 70-2, "RESEARCH, DEVELOPMENT, & ACQUISITION MATERIEL STATUS RECORDING"1c. AR 70-10, "R&D - TEST & EVALUATION DURING DEVELOPMENT AND ACQUISITION OF MATERIEL"1d. "AR 570-9, "MANPOWER AND EQUIPMENT CONTROL - HOST NATION SUPPORT"2. AR 700-9, "POLICIES OF THE ARMY LOGISTIC SYSTEM"3. AR 700-82, "JOINT REGULATION GOVERNING THE USE AND APPLICATION OF UNIFORM SOURCE MAINTENANCE AND RECOVERABILITY CODES"4. AR 700-127, "INTEGRATED LOGISTICS SUPPORT"5. AR 725-50, "REQUISITIONING, RECEIPT AND ISSUE SYSTEM"6. AR 750-1, "MAINTENANCE OF SUPPLIES & EQUIPMENT - ARMY MATERIEL MAINTENANCE CONCEPTS & POLICIES"7. AMC-R-700-27, "LEVEL OF REPAIR ANALYSIS (LORA) PROGRAM"8. AMC-R-750-10, "DEPOT MAINTENANCE INTERSERVICE"9. DA PAM 700-410. DA PAM 700-28, "INTEGRATED LOGISTIC SUPPORT PROGRAM ASSESSMENT ISSUES AND CRITERIA"11. DA PAM 700-50, "INTEGRATED LOGISTIC SUPPORT - DEVELOPMENTAL SUPPORTABILITY TEST AND EVALUATION GUIDE"12. DA PAM 700-55, "INSTRUCTIONS FOR PREPARING THE INTEGRATED LOGISTIC SUPPORT PLAN"12a. DA PAM 738-750, "THE ARMY MAINTENANCE MANAGEMENT SYSTEMS (TAMMS)"13. DA PAM 750-21, "LOGISTIC SUPPORT MODELLING"14. AMC PAM 700-4, "LOGISTICS SUPPORT ANALYSIS TECHNIQUES GUIDE (WITH PALMAN)"14a. AMC PAM 700-11, "LOGISTICS SUPPORT ANALYSIS REVIEW TEAM GUIDE"15. AMC PAM 750-2, "MAINTENANCE OF SUPPLIES AND EQUIPMENT GUIDE TO RELIABILITY CENTERED MAINTENANCE"16. MIL-STD-152, "TECH REVIEW GUIDELINES"17. MIL-STD-210A, "CLIMATIC EXTREMES FOR MILITARY EQUIPMENT"18. MIL-STD-470, -471, "MAINTAINABILITY STANDARDS"19. MIL-STD-756, "RELIABILITY MODELLING & PREDICTIONS"20. MIL-STD-780, "MAINTENANCE ENGINEERING ANALYSIS CONTROL NUMBER (MEACNS) FOR AERONAUTICAL EQUIPMENT, UNIFORM NUMBERING SYSTEM"21. MIL-STD-781, "RELIABILITY DESIGN QUALIFICATION AND PRODUCTION ACCEPTANCE TESTS: EXPONENTIAL DISTRIBUTION"22. MIL-STD-785B, "RELIABILITY PROGRAM FOR SYSTEMS AND EQUIPMENT DEVELOPMENT & PRODUCTION"23. MIL-STD-810, "ENVIRONMENTAL TEST METHODS & ENGINEERING GUIDELINES"24. MIL-STD-881, "WORK BREAKDOWN STRUCTURES FOR DEFENSE MATERIEL ITEMS"25. MIL-STD-882, "SYSTEM SAFETY PROGRAM REQUIREMENTS"26. MIL-STD-965, "PARTS CONTROL PROGRAM"27. MIL-STD-1369A, "INTEGRATED LOGISTIC SUPPORT PROGRAM REQUIREMENTS"28. MIL-STD-1388-1A, "LOGISTICS SUPPORT ANALYSIS"29. MIL-STD-1388-2A, "LOGISTICS SUPPORT ANALYSIS RECORD"

Name	Label	Description
		30. MIL-STD-1629, "PROCEDURES FOR PERFORMING A FAILURE MODE, EFFECTS & CRITICALITY ANALYSIS"
		31. MIL-HDBK-472, "MAINTAINABILITY PREDICTION"
		32. MIL-M-24100B, "FUNCTIONALLY ORIENTED MAINTENANCE MANUALS (FORM) FOR EQUIPMENT & SYSTEMS"
PM/DF		PROGRAM MGR DAT CONTAINS THOSE FILES AND DATA WHICH ARE NORMALLY DEVELOPED BY AND/OR A FILE RETAINED BY THE PROGRAM MANAGER FOR PROPER MANAGEMENT OF THE DEVELOPMENT PROGRAM. THESE FILES INCLUDE:
		1. ENGINEERING DRAWINGS
		2. ENGINEERING CHARACTERISTICS
		3. DT/OT RESULTS
		4. CONCEPT FORMULATION PACKAGE (CFP)
		5. DESIGN CONCEPT PAPER (DCP)
		6. TYPE TECHNICAL REVIEWS REQUIRED
		7. MILESTONE SCHEDULES
		8. FUNDING PROFILES
		9. REQUIRED OPERATIONAL CAPABILITIES (ROC)
		10. ITEM/EQUIPMENT SPECIFICATIONS
		11. ITEM/EQUIPMENT MISSIONS & FUNCTIONS
		12. EQUIPMENT, MANPOWER, AND TECHNICAL RISK ASSESSMENTS (FROM LSA TASK 301.2.3
		13. TRADE OFF DETERMINATION ANALYSIS (TOD)
		14. TRADE OFF ANALYSIS (TOA)
		15. BEST TECHNICAL APPROACH ANALYSIS (BTA)
		16. COST AND OPERATIONAL-EFFECTIVENESS ANALYSIS (COEA)

Name	Label	Description
ACQ/PLAN	ACQUISITION PLAN	PORTION OF THE PLAN DATA ARE UTILIZED TO ESTABLISH THE POTENTIAL SUPPORT CONCEPTS.
ALT/SYS/EQUIP/DATA	ALTERNATIVE SYS/EQUIP DATA	THE CHARACTERISTICS REPRESENTING EACH IDENTIFIED SIGNIFICANTLY DIFFERENT ALTERNATIVE SYSTEM/EQUIPMENT AND THEIR RELATED SUBSYSTEMS/SUBEQUIPMENTS (OR ASSEMBLIES).THE DATA WILL BE USED FOR PREPARATION OF A NEW SYSTEM/EQUIPMENT BASELINE COMPARASON SYSTEM DOCUMENT IN ACCORDANCE WITH LSA TASK 203.
ALT/SYS/EQPT/CHARAC	ALTERNATIVE SYSTEM/EQUIPMENT CHARACTERISTICS	THE RESULTS OF UPDATING THE DATA APPLICABLE TO THE EXISTING ALTERNATIVE SYSTEM/EQUIPMENT AND THE DATA APPLICABLE TO ANY NEW SYSTEM/EQUIPMENT ALTERNATIVES WHICH ARE TO BE USED FOR ANALYSIS IN THE DEVELOPMENT OF NEW SUPPORT CONCEPTS OR UPDATING EXISTING CONCEPTS.
ALT/SUP/CONC	ALTERNATIVE SUPPORT CONCEPTS FOR NEW SYS/EQUIPT	THE CORRELATED AND DOCUMENTED RESULTS OF DETERMINING THE VIABLE ALTERNATIVE SUPPORT CONCEPTS FOR INPUT IN THE TRADEOFF ANALYSIS EFFORT REQUIRED IN TASK 303.
BCS/DTA	BASELINE COMPARATIVE SYSTEM DATA	THE DOCUMENTATION REPRESENTING THE CURRENT SYSTEM/EQUIPMENT SUPPORT SYSTEM WHICH PROVIDES THE BASIS FOR THE DEVELOPMENT OF ALTERNATIVE SYSTEMS/EQUIPMENTS SUPPORT CONCEPTS. THE RAW DATA BASE FROM TASK 203 WILL BE USED IN PROCESS 302.2.1.2 TO PREPARE THE BASELINE SYSTEM/EQUIPMENT SUPPORT SYSTEM CONFIGURATION IN ADEQUATE DETAIL TO PERMIT PROJECTION OF THE POTENTIAL SYSTEM READINESS, MANPOWER AND PERSONNEL REQUIREMENTS AND O&S COSTS FOR EACH SUPPORT CONCEPT ALTERNATIVE.
BCS	BASELINE COMPARISON SYSTEM DATA	THE BASELINE COMPARISON SYSTEM DOCUMENTATION PROVIDES INPUT DATA FOR THE ANALYSIS AND PROJECTION OF POTENTIAL SYSTEM READINESS, MANPOWER AND PERSONNEL REQUIREMENTS, AND O & S COSTS FOR EACH POTENTIAL SUPPORT CONCEPT FOR EACH ALTERNATIVE SYSTEM/EQUIPMENT. REFERENCE: LSA TASK 203.
BTA	BEST TECHNICAL APPROACH ANALYSIS	TECHNICAL/ENGINEERING DATA REPRESENTING THE RESULTS OF A BEST TECHNICAL APPROACH (BTA) TO FULLFILLING THE CORRECTIVE ACTION NEEDS OF CURRENT SYSTEM/EQUIPMENT FUNCTIONS. SELECTED FOR CONSIDERATION IN THE DETERMINATION OF ALTERNATIVE SYSTEM/EQUIPMENT POTENTIAL SUPPORT CONCEPTS.
COEA	COST AND OPERATIONAL EFFECTIVENES ANALYSIS	DATA RELATING TO THE INVESTIGATION OF THE COST AND OPERATIONAL EFFECTIVENESS ANALYSIS FOR THE SYSTEM UNDER INVESTIGATION. THE DATA SHALL CONTAIN AT THE LEAST A COPY OF THE UPDATED COST AND OPERATIONAL EFFECTIVENESS ANALYSIS. REFERENCE: PROGRAM MANAGER'S DATA FILE ACQUIRING ACTIVITY FILES

Name	Label	Description
EQUIP/DESIGN/UPDTE/D	EQUIPMENT DESIGN UPDATE DATA	IDENTIFICATION OF SUBSYSTEM/SUBEQUIPMENT FUNCTIONS, OPERATIONS, AND CONFIGURATIONS, AND ANY NEW OR UPDATED ENGINEERING INFORMATION RELATED TO THE SYSTEM/EQUIPMENT.
EXIST/TOA/DATA	EXISTING TRADEOFF ANALYSIS DATA	THE RESULTS OF INITIAL TRADEOFF STUDIES PERFORMED AND DOCUMENTED DURING THE PRE-CONCEPT AND/OR CONCEPT EXPLORATION PHASES WHEN INTEGRATED WITH CURRENT INFORMATION PROVIDES AN ADDITIONAL INPUT TOWARDS THE DETERMINATION OF ALTERNATIVE SYSTEM/EQUIPMENTS POTENTIAL SUPPORT CONCEPT.
ILS PLAN	ILS PLAN	
INIT/ACT	INITIATION ACTION	THE REQUIRED ACTIONS OF THOSE (IF MORE THAN ONE) ACTIVITIES NECESSARY TO ACTUATE AN ILS ELEMENT ASSESSMENT FOR A SYSTEM AND/OR EQUIPMENT PROVIDES THE FORMAL AUTHORIZATION FOR THE PERFORMANCE OF AN ILS EFFORT.
JSOR	JOINT SERVICES OPERATIONAL REQUIREMENTS	PORTION OF THE JSOR DATA ARE UTILIZED TO ESTABLISH THE POTENTIAL SUPPORT CONCEPTS, READINESS FACTOR, AND COSTS INORDER TO DETERMINE THE VIABLE SUPPORT CONCEPT ALTERNATIVES.
NEW/UPDTD/ALT/SYS/EQ	NEW/UPDATED ALTERNATIVE SYS/EQUIP FOR ILS ELE. UPDATE	THE RESULTS OF IDENTIFYING THE NEW/UPDATED ALTERNATIVE SYSTEM/EQUIPMENT AND THEIR RELATED SUBSYSTEMS/SUBEQUIPMENTS (OR ASSEMBLIES) AND ANY CHANGES TO THE ALTERNATIVE SUPPORT CONCEPTS, COMPILED FOR ILS ELEMENT ANALYSIS IN ACCORDANCE WITH PROCESS 302.2.1.5A. THE EXTENT OF REPROCESSING ALTERNATIVE SYSTEM/EQUIPMENT AND SUPPORT CONCEPTS IN ACCORDANCE WITH PROCESS 302.2.1.5A ARE LIMITED TO THOSE PORTIONS OF SYSTEMS/EQUIPMENTS OR SUPPORT CONCEPTS THAT HAVE BEEN CHANGED OR ARE NEW.
NEW/ ALT/SUPP/CONCEP	NEW/UPDATED VIABLE SUPPORT CONCEPTS	THE SELECTED UPDATED/NEW SUPPORT CONCEPTS SHOWN TO BE VIABLE ALTERNATIVES FOR EACH UPDATED/NEW ALTERNATIVE SYSTEM/EQUIPMENT FOR FURTHER TRADEOFF ANALYSIS IN ACCORDANCE WITH LSA TASK 303.
O&O PLAN	OPERATIONS AND OPERABILITY PLAN	POSITION OF THE PLAN DATA ARE UTILIZED TO ESTABLISH THE POTENTIAL SUPPORT CONCEPTS, READINESS FACTORS, AND COSTS INORDER TO DETERMINE THE VIABLE SUPPORT CONCEPT ALTERNATIVES.
POT/ALT/SUPP/CONCEPT	POTENTIAL ALTERNATE SUPPORT CONCEPT	THE RESULTS OF INITIAL QUANTIFICATION OF ALTERNATIVE SUPPORT CONCEPT DATA FOR EACH ALTERNATIVE SYSTEM/EQUIPMENT AS ADDITIONAL INPUT INTO THE DETERMINATION AND QUANTIFICATION OF EACH INTEGRATED LOGISTIC SUPPORT ELEMENT.
QUANTIFIED/FACILITIE	QUANTIFIED FACILITIES	QUANTIFIED FACILITIES DATA FOR EACH ALTERNATIVE SYSTEM/EQUIPMENT FOR SELECTION OF VIABLE ALTERNATIVE SUPPORT CONCEPTS FOR EACH ALTERNATIVE SYSTEM/EQUIPMENT.

Name	Label	Description
QUANTIFIED/ILS/ASSES	QUANTIFIED ILS ASSESSMENT DATA	THE QUANTIFIED ILS DATA REPRESENTING THE ALTERNATIVE SYSTEM/EQUIPMENT PROVIDES ONE COMPLETE ILS ASSESSMENT EFFORT TOWARDS THE SELECTION OF VIABLE ALTERNATIVE SUPPORT CONCEPTS FOR EACH ALTERNATIVE SYSTEM/EQUIPMENT.
QUANTIFIED/MAINT/PLA	QUANTIFIED MAINTENANCE PLAN	THE QUANTIFIED MAINTENANCE PLANNING DATA FOR EACH ALTERNATIVE SYSTEM/EQUIPMENT FOR THE SELECTION OF VIABLE ALTERNATIVE SUPPORT CONCEPTS FOR EACH ALTERNATIVE SYSTEM/EQUIPMENT.
QUANT/REQTS	QUANTIFIED READINESS REQUIREMENTS	NEW OR UPDATED SYSTEM READINESS, COST AND MANPOWER FACTORS APPLICABLE TO THE UPDATED/NEW SYSTEM/EQUIPMENT OR IDENTIFIED SUBSYSTEMS/SUBEQUIPMENTS (OR ASSEMBLIES) USED FOR TOA CONSIDERATIONS IN LSA TASK 303.
QUANTIFIED/COMP/RESO	QUANTIFIED COMPUTER RESOURCE DATA	THE QUANTIFIED COMPUTER RESOURCE DATA FOR EACH ALTERNATIVE SYSTEM/EQUIPMENT FOR ASSESSMENT OF VIABLE ALTERNATIVE SUPPORT CONCEPTS FOR EACH ALTERNATIVE SYSTEM/EQUIPMENT.
QUANTIFIED/DESGN/INF	QUANTIFIED DESIGN INFLUENCE DATA	QUANTIFIED DESIGN INFLUENCE DATA FOR EACH ALTERNATIVE SYSTEM/EQUIPMENT FOR SELECTION OF VIABLE ALTERNATIVE SUPPORT CONCEPTS FOR EACH ALTERNATIVE SYSTEM/EQUIPMENT.
QUANTIFIED/T&T	QUANTIFIED TRAINING & TRAINING DEVICE (T&T) DATA	THE QUANTIFIED TRAINING AND TRAINING DEVICE DATA FOR EACH ALTERNATIVE SYSTEM/EQUIPMENT FOR THE SELECTION OF VIABLE ALTERNATIVE SUPPORT CONCEPTS FOR EACH ALTERNATIVE SYSTEM/EQUIPMENT.
QUANTIFIED/SUPPLY/SU	QUANTIFIED SUPPLY SUPPORT DATA	THE QUANTIFIED SUPPLY SUPPORT DATA FOR EACH ALTERNATIVE SYSTEM/EQUIPMENT FOR THE SELECTION OF VIABLE ALTERNATIVE SUPPORT CONCEPTS FOR EACH ALTERNATIVE SYSTEM/EQUIPMENT.
QUANTIFIED/TRANS/TRA	QUANTIFIED TRANSPORT/TRANSPORTABILITY ABILITY	THE QUANTIFIED TRANSPORT/TRANSPORTABILITY DATA FOR EACH ALTERNATIVE SYSTEM/EQUIPMENT FOR THE SELECTION OF VIABLE ALTERNATIVE SUPPORT CONCEPTS FOR EACH ALTERNATIVE SYSTEM/EQUIPMENT.
QUANTIFIED/TECH/DATA	QUANTIFIED TECHNICAL DATA	THE QUANTIFIED TECHNICAL DATA FOR EACH ALTERNATIVE SYSTEM/EQUIPMENT FOR THE SELECTION OF VIABLE ALTERNATIVE SUPPORT CONCEPTS FOR EACH ALTERNATIVE SYSTEM/EQUIPMENT.
QUANTIFIED/PACK/HAND	QUANTIFIED PACKAGING HANDLING/STORAGE	THE QUANTIFIED PACKAGING/HANDLING/STORAGE DATA FOR EACH ALTERNATIVE SYSTEM/EQUIPMENT FOR THE SELECTION OF VIABLE ALTERNATIVE SUPPORT CONCEPTS FOR EACH ALTERNATIVE SYSTEM/EQUIPMENT.
QUANTIFIED/MANPWR/PE	QUANTIFIED MANPOWER & PERSONNEL DATA	THE QUANTIFIED MANPOWER & PERSONNEL DATA FOR EACH ALTERNATIVE SYSTEM/EQUIPMENT FOR THE SELECTION OF VIABLE ALTERNATIVE SUPPORT CONCEPTS FOR EACH ALTERNATIVE SYSTEM/EQUIPMENT.

Name	Label	Description
QUANTIFIED/SE/TMDE	QUANTIFIED SE/TMDE DATA	THE QUANTIFIED SE/TMDE DATA FOR EACH ALTERNATIVE SYSTEM/EQUIPMENT FOR THE SELECTION OF VIABLE ALTERNATIVE SUPPORT CONCEPTS FOR EACH ALTERNATIVE SYSTEM/EQUIPMENT.
QUANTIFIED/S&I	QUANTIFIED S&I	THE QUANTIFIED STANDARDIZATION AND INTEROPERABILITY (S&I) DATA FOR EACH ALTERNATIVE SYSTEM/EQUIPMENT FOR THE SELECTION OF VIABLE ALTERNATIVE SUPPORT CONCEPTS FOR EACH ALTERNATIVE SYSTEM/EQUIPMENT.
QUANT/READ/REQ	QUANTIFIED READINESS REQUIREMENT	DOCUMENTED READINESS INFORMATION NECESSARY TO DETERMINE VIABLE ALTERNATIVE SUPPORT CONCEPT AND TOA ACTIONS.
QUANT/ILS/ELEMENTS	QUANTIFIED UPDATED/NEW ILS ELEMENTS	THE RESULTS OF QUANTIFYING EACH ILS ELEMENT SPECIFIED IN PROCESS 302.2.1.5A, APPLIED TO PROCESS 302.2.2.5 AS AN INPUT IN THE SELECTION OF VIABLE ALTERNATIVE SUPPORT CONCEPTS.
ROC	REQUIRED OPERATIONAL CAPABILITY	PORTION OF THE ROC DATA ARE UTILIZED TO ESTABLISH THE POTENTIAL SUPPORT CONCEPTS, READINESS FACTORS, AND COSTS IN ORDER TO DETERMINE THE VIABLE SUPPORT CONCEPT ALTERNATIVES.
SEL/SYS/CONC	SELECTED ALT NEW SYS/EQPT CONCEPTS FOR ANALYSIS	CORRELATED AND DOCUMENTED DATA FOR EACH IDENTIFIED NEW ALTERNATIVE SYSTEM/EQUIPMENT AND THEIR SUBSYSTEMS/SUBEQUIPMENTS (OR ASSEMBLIES) FOR USE IN THE IDENTIFICATION OF ALTERNATIVE SUPPORT CONCEPTS.
ILS/S&I	SELECTED ILS ELEMENT- S&I	THE STANDARDIZATION AND INTEROPERABILITY DATA REQUIREMENTS FROM ARMY REGULATION AR 700-127, APPENDIX E, AND OTHER REGULATIONS & SPECIFICATIONS MAINTAINED IN THE PROGRAM POLICY FILE.
ILS/SE/TMDE	SELECTED ILS ELEMENT- SE/TMDE	THE SE/TMDE DATA REQUIREMENTS FROM ARMY REGULATION AR 700-127, APPEN. E, AND OTHER REGULATIONS & SPECIFICATIONS MAINTAINED IN THE PROGRAM POLICY FILE.
ILS/SUPPLY/SUPPORT	SELECTED ILS ELEMENT- SUPPLY SUPPORT	THE SUPPLY SUPPORT DATA REQUIREMENTS FROM ARMY REGULATION AR 700-127, APPENDIX E, AND OTHER REGULATIONS & SPECIFICATIONS MAINTAINED IN THE PROGRAM POLICY FILE.
SEL/ELE/DATA/BASE	SELECTED ILS ELEMENT/DATA BASE	THE POLICY FILES PROVIDE THE REQUIRED SPECIFICATIONS, POLICIES, AND THE EXISTING DATA BASE INFORMATION APPLICABLE TO EACH ILS ELEMENT UNDER CONSIDERATION.
ILS/MANPWR/PERS	SELECTED ILS ELEMENT- MANPOWER & PERSONNEL	THE MANPOWER & PERSONNEL PLANNING REQUIREMENTS FROM ARMY REGULATION AR 700-127, APPENDIX E, AND OTHER REGULATIONS & SPECIFICATIONS MAINTAINED IN THE PROGRAM POLICY FILE.

Name	Label	Description
ILS/PACK/HAND/STORE	SELECTED ILS ELEMENT- PACKAGING/ HANDLING/ STORAGE	THE PACKAGING/HANDLING/STORAGE DATA REQUIREMENTS FROM ARMY REGULATION AR 700-127, APPENDIX E, AND OTHER REGULATIONS & SPECIFICATIONS MAINTAINED IN THE PROGRAM POLICY FILE.
ILS/FACILITIES	SELECTED ILS ELEMENT- FACILITIES	THE FACILITIES DATA REQUIREMENTS FROM ARMY REGULATION AR 700-127, APPENDIX E, AND OTHER REGULATIONS & SPECIFICATIONS MAINTAINED IN THE PROGRAM POLICY FILE.
ILS/DESGN/INFL	SELECTED ILS ELEMENT- DESIGN INFLUENCE	THE REQUIREMENTS CONSTITUTING DESIGN INFLUENCE EXTRACTED FROM ARMY REGULATION AR 700-127, APPENDIX E, AND OTHER REGULATIONS AND SPECIFICATIONS MAINTAINED IN THE PROGRAM POLICY FILES.
ILS/COMP/RESOURCE	SELECTED ILS ELEMENT- COMPUTER RESOURCE	THE REQUIREMENTS CONSTITUTING COMPUTER RESOURCE EXTRACTED FROM ARMY REGULATION AR 700-127, APPENDIX E, AND OTHER REGULATIONS & SPECIFICATIONS MAINTAINED IN THE PROGRAM POLICY FILE.
ILS/MAINT/PLAN	SELECTED ILS ELEMENT- MAINTENANCE PLAN	THE MAINTENANCE PLANNING REQUIREMENTS FROM ARMY REGULATION AR 700-127, APPENDIX E, AND OTHER REGULATIONS & SPECIFICATIONS MAINTAINED IN THE PROGRAM POLICY FILE.
ILS/T&T	SELECTED ILS ELEMENT- TRAINING & TRAINING DEVICE (T&T)	THE TRAINING AND TRAINING DEVICE (T&T) DATA REQUIREMENTS FROM ARMY REGULATION AR 700-127, APPENDIX E, AND OTHER REGULATIONS & SPECIFICATIONS MAINTAINED IN THE PROGRAM POLICY FILE.
ILS/TECH/DATA	SELECTED ILS ELEMENT- TECHNICAL DATA	THE TECHNICAL DATA REQUIREMENTS FROM ARMY REGULATION AR 700-127, APPENDIX E, AND OTHER REGULATIONS AND SPECIFICATIONS MAINTAINED IN THE PROGRAM POLICY FILE.
ILS/TRANS/TRANS/FAC	SELECTED ILS ELEMENT- TRANSPORT/ TRANSPOR'ITY FACILITY	THE TRANSPORT/TRANSPORTABILITY DATA REQUIREMENTS FROM ARMY REGULATION AR 700-127, APPENDIX E, AND OTHER REGULATIONS & SPECIFICATIONS MAINTAINED IN THE PROGRAM POLICY FILE.
S&I	STANDARDIZ AND	PORTIONS OF THIS ILS ELEMENT ARE USED TO IDENTIFY, IF ANY, INTERSERVICES OR ALLIED OR BOTH INTEREST IN THE SYSTEM/EQUIPMENT UNDER INTEROP'LITY CONSIDERATION. EACH SERVICE ALLY SO IDENTIFIED IS CONSIDERED AS PART OF A POTENTIAL SUPPORT CONCEPT OR A SUPPORT CONCEPT UNTO ITSELF.

Name	Label	Description
SUBSYS/SUBEQUIP/CHAR	SUBSYSTEM/ SUBEQUIPMENT CHARACTERIS- TICS	BASED ON THE WORK BREAKDOWN STRUCTURE DATA DEVELOPED IN LSA TASK 301, THE IDENTIFIED SUBSYSTEMS/SUBEQUIPMENTS (OR ASSEMBLIES) OF EACH ALTERNATIVE SYSTEM/EQUIPMENT (OR EACH NEW ALTERNATIVE SYSTEM/EQUIPMENT) AND THEIR CHARACTERISTICS WHICH ARE REQUIRED FOR THE UPDATE OR DEVELOPMENT OF NEW OR REVISED ALTERNATIVE SUPPORT CONCEPTS. REFERENCE: MIL-STD-881A, WORK BREAKDOWN STRUCTURES FOR DEFENSE MATERIELS ITEMS
SYS/EQP/ALT/IDENT	SYSTEM/EQUIP ALTERNATIVE IDENT	THE DATA DOCUMENTATION PRODUCED BY THE COMBAT DEVELOPER THAT IDENTIFY ALTERNATIVE SYSTEM/EQUIPMENT ALTERNATIVES FULFILLING MISSION AREA REQUIREMENTS.
THREAT/ANALYSIS/DATA	THREAT ANALYSIS DATA	THE RESULTS OF INITIAL THREAT STUDIES PERFORMED AND DOCUMENTED DURING THE PRE-CONCEPT AND/OR CONCEPT EXPLORATION PHASES OR DURING OTHER PHASES OF THE PROGRAM PROVIDES DATA THAT CAN BE APPLIED TOWARDS THE IDENTIFICATION OF POTENTIAL ALTERNATIVE SUPPORT CONCEPTS. REFERENCES: TRADOC-R 381-1, THREAT MANAGEMENT AR-381-11 THREAT SUPPORT TO U.S. ARMY FORCE, COMBAT, AND MATERIAL DEVELOPEMENT
TOA	TRADEOFF ANALYSIS DATA	THE RESULTS OF TRADEOFF ANALYSES PERFORMED ON EACH ALTERNATIVE SYSTEM/EQUIPMENT REQUIRED FOR UPDATING EXISTING ALTERNATIVE SYSTEM/EQUIPMENT CONCEPTS AND NEW ALTERNATIVE SYSTEM/EQUIPMENT CONCEPTS IN PROCESS 302.2.1, AND UPDATING ALTERNATIVE SUPPORT CONCEPTS AND NEW SUPPORT CONCEPTS IN PROCESS 302.2.2.3.
UPDTD/ALT/SUPP/CONCE	UPDATED/NEW ALTERNATIVE SUPPORT CONCEPTS	THE RESULTS OF UPDATING EXISTING OR PREPARING NEW QUANTIFICATION OF ALTERNATIVE SUPPORT CONCEPT DATA FOR EACH UPDATED OR NEW ALTERNATIVE SYSTEM/EQUIPMENT TO PROVIDE AN INPUT INTO THE DETERMINATION OF VIABLE ALTERNATIVE SUPPORT CONCEPTS.
NEW/ALT/SYS/CONFIG/D	UPDATED/NEW SYS/EQUIP CONFIG DATA	ADDITIONAL DATA DEFINING THE DETAILS OF EXISTING ALTERNATIVE SYSTEM/EQUIPMENT CONFIGURATION OR THE GENERATION OF NEW SYSTEM/EQUIPMENT EXTRACTED FROM THE PROGRAM MANAGERS FILE FOR USE IN THE ANALYSIS PROCESS TO UPDATE EXISTING CONCEPTS AND/OR DEVELOP NEW SUPPORT CONCEPTS.
WBS	WORK BREAKDOWN STRUCTURE	DOCUMENTED RESULTS OF THE WORK BREAKDOWN STRUCTURE EFFORT PERFORMED IN PROCESS 301.2.1.2A, IN PARTICULAR, THE IDENTIFICATION OF THE LEVELS 2 AND 3 SUBSYSTEMS AND SUBEQUIPMENTS. THE OUTPUT IS REQUIRED IN PROCESS 302.2.2 TO ESTABLISH THE OVERALL ALTERNATIVE SYSTEM PACKAGE, THE ALTERNATIVE SUPPORT CONCEPT UPDATE, OR A NEW ALTERNATIVE SUPPORT CONCEPT. REFERENCE: MIL-STD-881A, WORK BREAKDOWN STRUCTURES FOR DEFENSE MATERIELS ITEMS

Name	Label	Description
PM/ILSMT	PROGRAM MANAGER DATA FILE	THE PROGRAM MANAGER OR THOSE ACTIVITIES, AGENCIES, OR AUTHORITIES THAT ARE RESPONSIBLE FOR THE INITIATION OF THE REQUIREMENT FOR AN ILS ELEMENT ASSESSMENT DURING A DEVELOPMENT PROGRAM FOR A SYSTEM AND/OR EQUIPMENT IN ACCORDANCE WITH AR 700-127. THE KEY ACTION (OUTPUT) REQUIRED OF THIS EXTERNAL ENTITY IS THE DIRECTIVE, AUTHORITY, OR OTHER DOCUMENTATION THE INITIATES THE REQUIREMENT FOR THE APPLICATION OF THIS ILS ASSESSMENT TO A SPECIFIC SYSTEM/EQUIPMENT DEVELOPMENT PROGRAM AT A SPECIFIED POINT IN ITS LIFE CYCLE.

ANNEX C

STRUCTURED SYSTEMS ANALYSIS

Fundamentals

ANNEX C
STRUCTURED SYSTEMS ANALYSIS

Fundamentals

Structured Systems Analysis (SSA) has recently become an industry standard for generating Data Flow Diagrams (replacing "logic diagrams" or "flow charts") to aid in coordinating the functions to be performed by a computer program and its associated Inputs/Outputs (I/O). During the SSA, each set of "flow charts" can be checked by the potential user to assure that there is complete agreement on what is to be done by the program, and how it is to be accomplished. It also provides considerable flexibility for updating or changing the program.

Six basic elements (see figure 1) are used in SSA:

1. Process (PRC)
2. Data Flow (DAF)
3. Data Store (DAS)
4. External Entity (EXT)
5. Data Flow Diagram (DFD)
6. Data Dictionary (DCT)

PROCESS (Represented by a Circle):

A function or operation to be performed which can be explained by a set of instructions representing a single task, e.g., "calculate interest on a loan", "prepare a draft report". If the Process description is too complex to describe in a few steps, it may be necessary to develop a lower level description (see below).

DATA FLOW (Lines interconnecting Processes or I/Os):

Each function or Process cannot be a stand-alone in a complex network. To have any meaning in a program, each process must be initiated by a previous action and/or provided information on which to act. Furthermore, a Process must result in an output which is the input to the next logical Process. These inputs, outputs, or initiating actions are identified as Data Flows, and are represented by the Data Flow lines indicating its point of origin and the process to which it provides data.

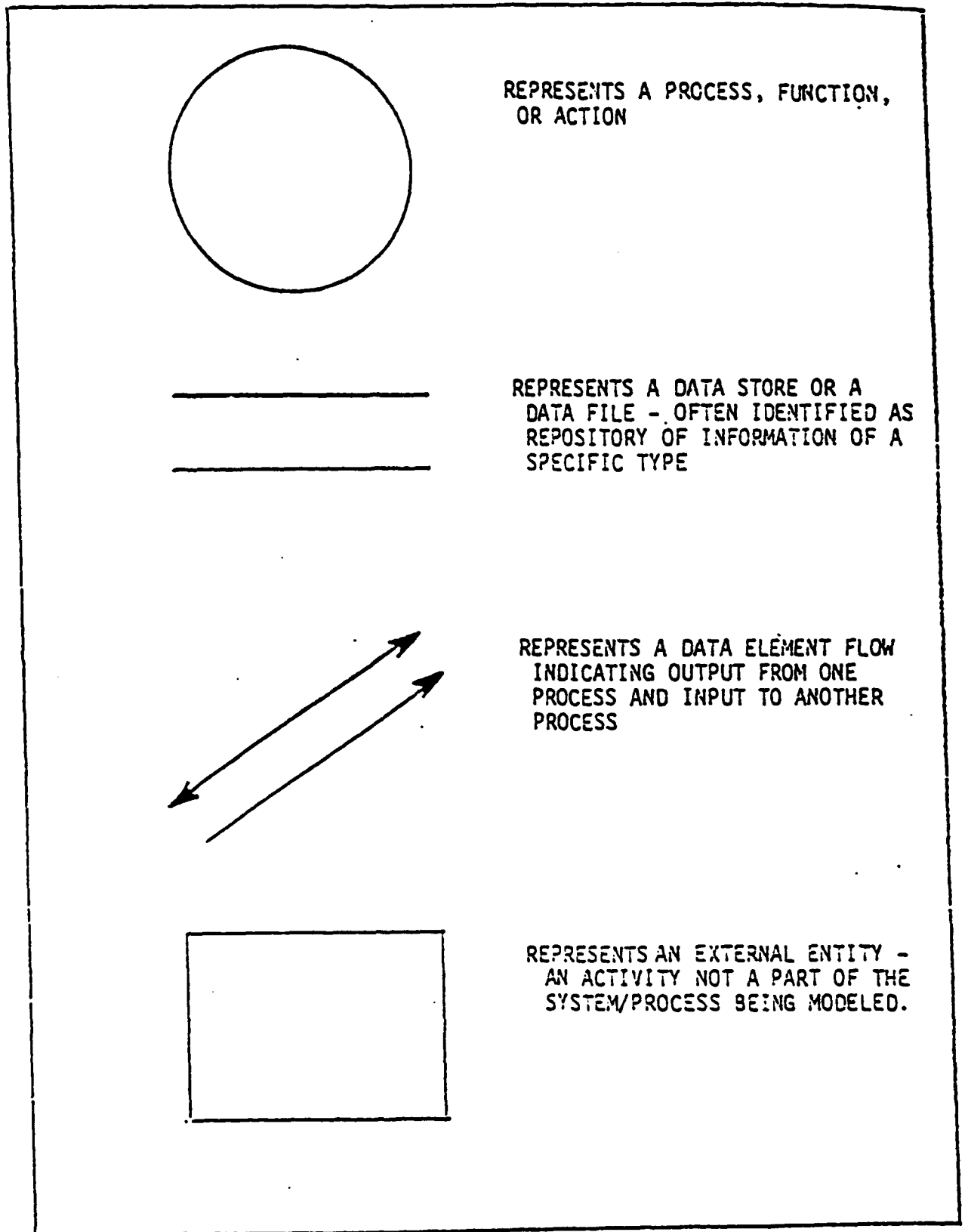

Figure 1. Standard DFD Symbol Definitions

DATA STORE (Represented by two parallel lines):

Although some Processes generate data used as input to a succeeding Process, there is often a need to "gather or collect" information from files in which it is stored. This information may come from an external source (such as a MIL-STD, Army regulation, historical experience files, etc.), or an internal source or file in which data is temporarily stored for use by succeeding processes. These Data Stores can be visualized as a "file cabinet", in which the data are stored for later retrieval).

EXTERNAL ENTITY (Represented by a Rectangle):

Each program or logical process must have an initiating action, a "point" of disposition of the results, and possibly input guidance or instructions. Each of these have authorities, functions, or applications which are independent of the program Process (although required by the program Process). Thus, these activities, agencies, or facilities are considered "External Entities" to the program.

DATA FLOW DIAGRAM:

The general arrangement of the above can be readily seen. First, the circle or Process describes what has to be done; the interconnecting lines represent the Data Flows, together with the specific description of all I/Os. The Data Stores identify the source and/or file designation of a data base, and the External Entities represent those activities remote from the Process, which are the source of guidance or the recipients of the program. This combination of Processes, Data Flows, Data Stores, and External Entities constitutes a "Data Flow Diagram". The unique feature of the Data Flow Diagram (DFD) is that each process can be considered independently, permitting a change to be made in one Process without a major change in the overall program.

DATA DICTIONARY:

The Data Dictionary consists of a complete description of each of the basic elements. For the Process, it contains a step-by-step description of what has to be performed. The description of the Data Flow identifies the nomenclature of the data, a detailed description of its content, and its source. The Data Stores and External Entities are described, including possible location.

The Data Dictionary (a living document) begins with a description of the first Process and is continually built-up as the Data Flow Diagrams are expanded, detailed, and eventually completed.

APPROACH TO PERFORMING STRUCTURED SYSTEM ANALYSIS:

The best approach to Structured Systems Analysis is to assume that the program consists of a series of processes, each of which are to be assigned to an inexperienced analyst. Each analyst is to be walked through the assigned process of the Program, explaining step-by-step what functions have to be performed or what actions have to be taken to accomplish the process. The analyst is also informed where the information is coming from (input Data Flow), what is to be generated by each process (output Data Flow), where the data base may to be found (Data Stores), and who to contact for guidance (External Entities).

The best way to initiate a SSA is to set down the point of origin of a program, its final goal(s), and the intermediate functions or actions needed to get from beginning to goal. Each step should be considered as a Process - some may be sequential and others parallel. Then, the steps needed to accomplish the Process should be described. If the description is complex and needs intermediate steps, the Process is then a candidate for an "explosion". That is, the top (or upper) level Process is considered as a "project" and its own Data Flow Diagram is prepared.

When writing the step-by-step procedures in the Process, certain elements of data (or information) must be made available for the procedure. Each element of data is considered as an input Data Flow, which is identified and described. The product (or result) of a Process is an output Data Flow element.

Each Data Flow to the Process must originate from:

1. an earlier Process
2. a Data Store (or file)
3. an External Entity.

These sources are also identified, described and put into the Data Dictionary. As soon as the last portion of the Data Flow Diagram has been described, the SSA is complete.

The Structured Analysis phase is followed by Structured Design, then by programming and finally software test and validation. The organization of Structured Analysis and its relationship to Structured System Design is shown on Figure 2.

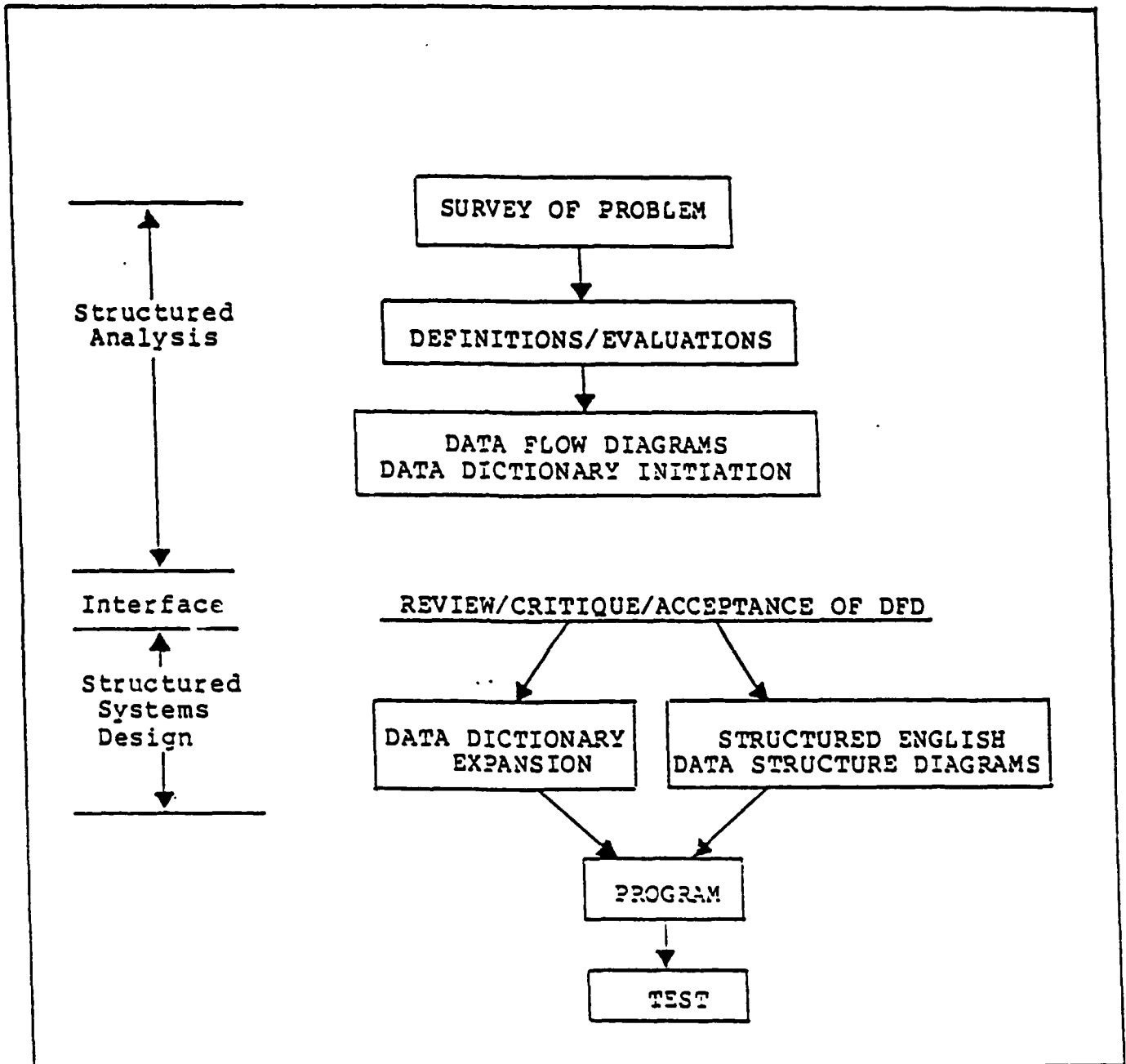

Figure 2. Structured Analysis and Structured Systems Design Organization

ANNEX D

VERT BATCH INPUT FILES FOR LSA SUBTASKS 302.2.1 AND 302.2.2

NOTE: Our presentation of VERT methodology, naming conventions and default settings are reproduced verbatim in each report to facilitate the use of VERT batch input files, which are designed specific to the given task or subtask.

VERT APPLICATION METHODOLOGY

BACKGROUND:

Venture Evaluation and Review Technique (VERT) was developed as a network analysis technique to facilitate management decision making. It allows a systematic planning and control of programs and enables managers to find solutions to real life managerial problems.

The terms of the APJ contract require the provision of batch files for each of the VERT networks associated with the various Data Flow Diagrams in the APJ 966 projects.

APJ has been successful in adopting a method for the creation of these networks using the existing EXCELERATOR software package and establishing a naming convention compatible with that used in the Data Flow Diagrams. To do this APJ has made use of the PC model of VERT. A Structured Analysis project was used for this purpose. The prototype VERT network structure was made for one top level and one lower level data flow diagram.

The PC model of VERT has certain limitations built into it. To overcome some of these limitations, certain conventions were used to create the input files. To maintain full generality a set of "dummy" default values were established. The model allows the user to alter the default values of time, cost, and performance to satisfy their specific requirements.

METHODOLOGY:

The basic symbols used to structure the network are :

- (i) **SQUARES** - to indicate NODES. These are decision points in the project, or points beyond which the project cannot proceed unless certain criteria are met. There are two types of nodes, one which supports input operations and, the second type which supports output operations.
- (ii) **LINES** - to indicate ARCS which are activities that have time, cost, and performance criteria associated with them.

In practice, however, both the arcs and nodes are similar, in that both have time, cost, and performance criteria associated with them. The arcs have a primary and a cumulative set of time, cost, and performance criteria whereas the nodes have only a single cumulative set.

- (iii) **NAMING CONVENTIONS** - Efforts have been made to keep the naming convention as compatible as possible to the Data Flow Diagrams. The naming convention used is displayed below.

NODES - All nodes are prefixed with the letter N. The individual Nodes are identified by a number and a letter. The number refers to the number of the node within the diagram and the letter refers to the diagram number in the project. In the event that a node has been referenced in an earlier diagram they also carry the number of the node in the earlier diagram as a prefix to the individual node number.

N2.4A

- N** - All nodes are prefixed with the letter N
- 2** - Gives the number of the node it relates to in a higher level diagram or an earlier data flow diagram within the project. In this case it refers to node N2 of the top level diagram.
- 4** - Gives the number of the node in the present data flow diagram.
- A** - The nodes in each subsequent explosion are allotted an alphabetical suffix indicating the number of the explosion diagram in the particular project. In this case it is the first lower level diagram within the project.

ARCS - All arcs are prefixed with either the letter C or E. The individual Arcs are identified by two numbers. The first number refers to the number of the arc within the diagram and the second number refers to the number of the diagram within the project. In the event that an arc has been referenced in an earlier diagram they also carry the number of the arc in the earlier diagram as a prefix to the individual arc number. The arcs which are identified by the letter E have direct reference to a process in the corresponding data flow diagram and as such are named the same as the process itself.

- C - All arcs are prefixed with the letter C. In some cases, however, arcs carry a prefix of E. These particular arcs correspond to a process within the data flow diagram and are thus named the same as the process itself.
- 3.3 - Gives the number of the arc it relates to in a higher level diagram or an earlier data flow diagram within the project. In this case it refers to arc number 3 in lower level diagram #3 within the project.
- 8.4 - Indicates that this particular arc is the #8 arc in the #4 lower level diagram of the project.

BATCH FILES

- INPUT FILES - The input file names are given the extension *.IN.
- OUTPUT FILES - The simulation output files are given the extension *.OU.
- PRINT FILES - The print files have been given the extension *.PR.

(This would allow subsequent updates of the input files to be numbered as IN1...,OU1...,PR1... etc.)

DEFAULT SETTINGS:

Control Record:

- (i) The output option selected is "0" which provides a detailed listing, and high level of summary information.
- (ii) The input record listing option selected is "0" which prints all input records.
- (iii) The composite terminal node output option selected is "16" which assumes family mode and intrafamily transfer of histogram data.
- (iv) The number of iterations used are "10" in the demonstration model to facilitate operation in the debug mode if required.
- (v) The composite node name and the network name are

left as blanks.

- (vi) In the run identification the name of the corresponding Data Flow Diagram is used as identification for the network description.

Arc Records:

- (i) For each of the arcs the following records are provided:
 - (a) Master Arc Record
 - (b) Time Distribution Satellite
 - (c) Cost Distribution Satellite
 - (d) Performance Distribution Satellite
- (ii) The Distribution Satellite Records are created to provide a uniform statistical distribution.
- (iii) The default values used for the minimum and maximum in each criteria are:

TIME	10.0	20.0
COST	10.0	100.0
PERFORMANCE	10.0	50.0

Node Records:

- (i) Input Logic - The input logic for the nodes are either "INITIAL" or "AND".
- (ii) Output Logic - The output logic has been defaulted to "AND" or "TERMINAL".
- (iii) The output option indicator and the storage option indicator are defaulted to read "0".
- (iv) The node description has also been left blank.

(It is again noted that the user can change the default values to desired values as identified by the particular requirement and applications.)

DOCUMENTATION:

With every project report APJ will be providing the following documents relating to the VERT:

- (i) A VERT network diagram corresponding to a particular data flow diagram.
- (ii) A print out of the VERT network inputs for the particular data flow diagrams.
- (iii) A floppy disc containing the sample input, print, and the simulation output files for the default VERT network.

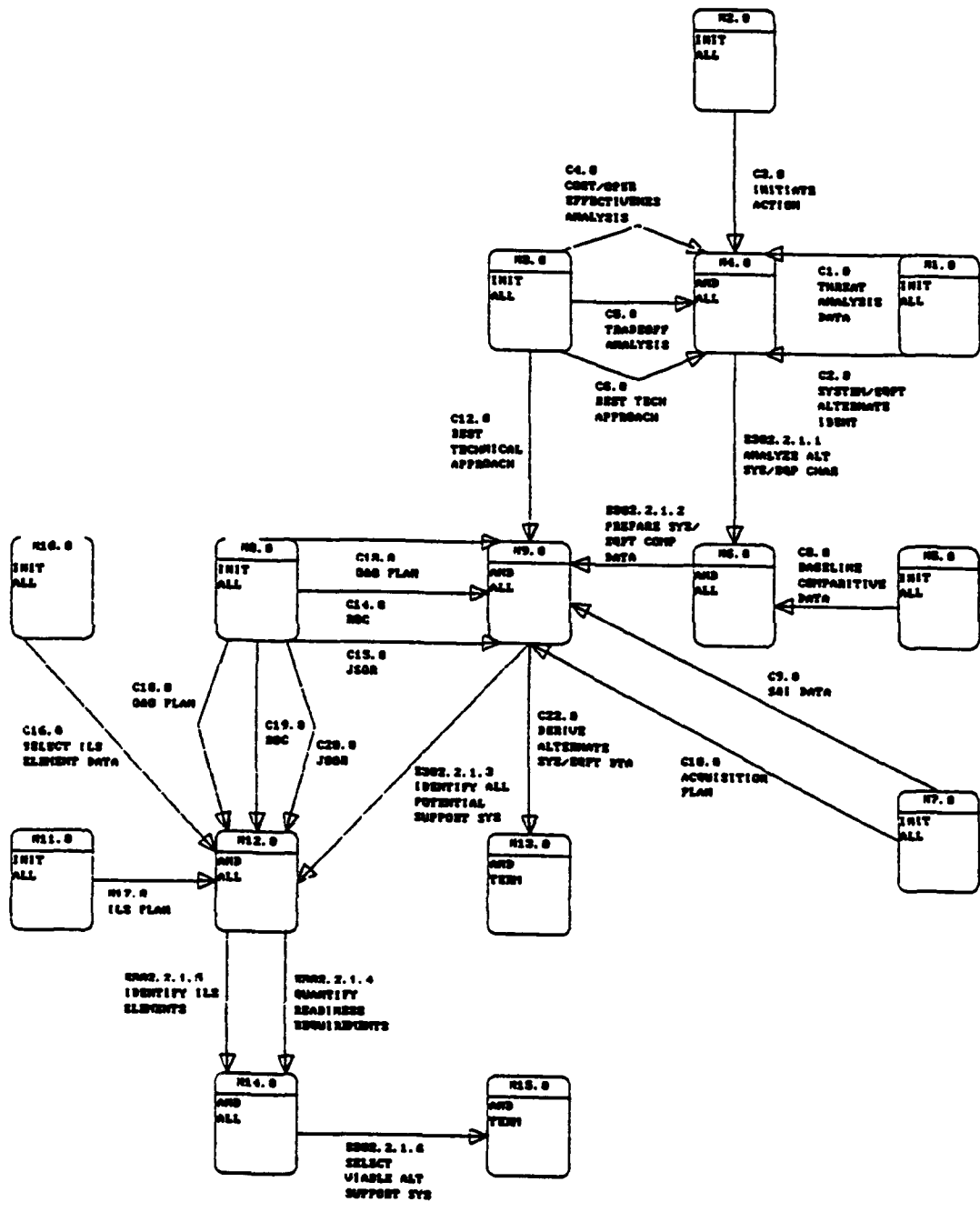

URGENT TOP LEVEL
 Created by: SID
 Revised by: SID
 Date changed: 20-080-09

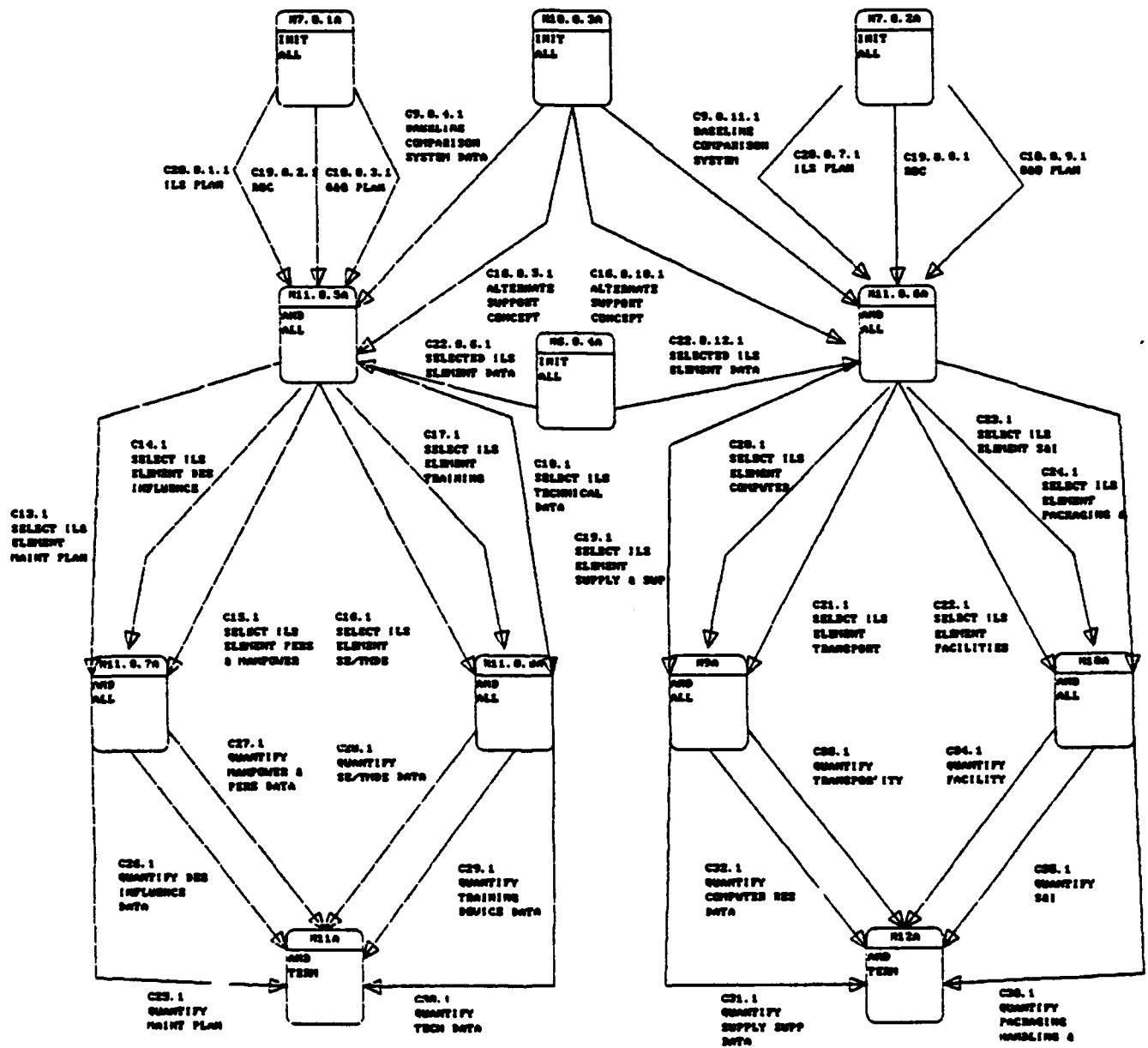

VERT 308.2.1.30
 Created by: SID
 Revised by: SID
 Date changed: 29-08-99

	1	2	3	4	5	6	7	
	12345678901234567890123456789012345678901234567890123456789012345678901234							
1.	0016	10	QUANTIFICATION OF ILS ELEMENT SELECTION					
	+	+	+	+	+	+	+	
2.	C20.1.1	N7.0.1A	N11.0.5A	1.0	ILS PLAN			
3.	C20.1.1	DTIME	1	2	10.0	20.0		
4.	C20.1.1	DCOST	1	2	10.0	100.0		
5.	C20.1.1	DPERF	1	2	10.0	50.0		
	+	+	+	+	+	+	+	
6.	C19.2.1	N7.0.1A	N11.0.5A	1.0	REQUIRED OPERATIONAL CAPABILITIES			
7.	C19.2.1	DTIME	1	2	10.0	20.0		
8.	C19.2.1	DCOST	1	2	10.0	100.0		
9.	C19.2.1	DPERF	1	2	10.0	50.0		
	+	+	+	+	+	+	+	
10.	C18.3.1	N7.0.1A	N11.0.5A	1.0	O & O PLAN			
11.	C18.3.1	DTIME	1	2	10.0	20.0		
12.	C18.3.1	DCOST	1	2	10.0	100.0		
13.	C18.3.1	DPERF	1	2	10.0	50.0		
	+	+	+	+	+	+	+	
14.	C9.0.4.1	N10.0.3A	N11.0.5A	1.0	BASELINE COMPARISON SYSTEM DATA			
15.	C9.0.4.1	DTIME	1	2	10.0	20.0		
16.	C9.0.4.1	DCOST	1	2	10.0	100.0		
17.	C9.0.4.1	DPERF	1	2	10.0	50.0		
	+	+	+	+	+	+	+	
18.	C16.5.1	N10.0.3A	N11.0.5A	1.0	ALTERNATE SUPPORT CONCEPT			
19.	C16.5.1	DTIME	1	2	10.0	20.0		
20.	C16.5.1	DCOST	1	2	10.0	100.0		
21.	C16.5.1	DPERF	1	2	10.0	50.0		
	+	+	+	+	+	+	+	
22.	C22.6.1	N6.0.4A	N11.0.5A	1.0	SELECTED ILS ELEMENT DATA			
23.	C22.6.1	DTIME	1	2	10.0	20.0		
24.	C22.6.1	DCOST	1	2	10.0	100.0		
25.	C22.6.1	DPERF	1	2	10.0	50.0		
	+	+	+	+	+	+	+	
26.	C20.7.1	N7.0.2A	N11.0.6A	1.0	ILS PLAN			
27.	C20.7.1	DTIME	1	2	10.0	20.0		
28.	C20.7.1	DCOST	1	2	10.0	100.0		
29.	C20.7.1	DPERF	1	2	10.0	50.0		
	+	+	+	+	+	+	+	
30.	C19.8.1	N7.0.2A	N11.0.6A	1.0	REQUIRED OPERATIONAL CAPABILITIES			
31.	C19.8.1	DTIME	1	2	10.0	20.0		
32.	C19.8.1	DCOST	1	2	10.0	100.0		
33.	C19.8.1	DPERF	1	2	10.0	50.0		
	+	+	+	+	+	+	+	
34.	C18.9.1	N7.0.2A	N11.0.6A	1.0	O & O PLAN			
35.	C18.9.1	DTIME	1	2	10.0	20.0		
36.	C18.9.1	DCOST	1	2	10.0	100.0		
37.	C18.9.1	DPERF	1	2	10.0	50.0		
	+	+	+	+	+	+	+	
38.	C16.10.1	N10.0.3A	N11.0.6A	1.0	ALTERNATE SUPPORT CONCEPT			
39.	C16.10.1	DTIME	1	2	10.0	20.0		
40.	C16.10.1	DCOST	1	2	10.0	100.0		
41.	C16.10.1	DPERF	1	2	10.0	50.0		
	+	+	+	+	+	+	+	
42.	C9.11.1	N10.0.3A	N11.0.6A	1.0	BASELINE COMPARISON SYSTEM			
43.	C9.11.1	DTIME	1	2	10.0	20.0		
44.	C9.11.1	DCOST	1	2	10.0	100.0		
45.	C9.11.1	DPERF	1	2	10.0	50.0		
	+	+	+	+	+	+	+	

134.	C34.1	N10A	N12A	1.0	QUANTIFY FACILITY						
135.	C34.1	DTIME 1		2	10.0	20.0					
		1	2	3	4	5	6	7			
		1234567890123456789012345678901234567890123456789012345678901234									
1		NEW NETWORK			PAGE 4						
		1	2	3	4	5	6	7			
		1234567890123456789012345678901234567890123456789012345678901234									
136.	C34.1	DCOST 1		2	10.0	100.0					
137.	C34.1	DPERF 1		2	10.0	50.0					
		+	+	+	+	+	+	+	+	+	+
138.	C35.1	N10A	N12A	1.0	QUANTIFY STANDARDIZATION AND INOPERABILITY						
139.	C35.1	DTIME 1		2	10.0	20.0					
140.	C35.1	DCOST 1		2	10.0	100.0					
141.	C35.1	DPERF 1		2	10.0	50.0					
		+	+	+	+	+	+	+	+	+	+
142.	C36.1	N10A	N12A	1.0	QUANTIFY PACKAGING AND HANDLING						
143.	C36.1	DTIME 1		2	10.0	20.0					
144.	C36.1	DCOST 1		2	10.0	100.0					
145.	C36.1	DPERF 1		2	10.0	50.0					
		+	+	+	+	+	+	+	+	+	+
146.	ENDARC										
		+	+	+	+	+	+	+	+	+	+
147.	N7.0.1A	1 2 0 0									
		+	+	+	+	+	+	+	+	+	+
148.	N11.0.5A2	2 0 0									
		+	+	+	+	+	+	+	+	+	+
149.	N10.0.3A1	2 0 0									
		+	+	+	+	+	+	+	+	+	+
150.	N6.0.4A	1 2 0 0									
		+	+	+	+	+	+	+	+	+	+
151.	N7.0.2A	1 2 0 0									
		+	+	+	+	+	+	+	+	+	+
152.	N11.0.6A2	2 0 0									
		+	+	+	+	+	+	+	+	+	+
153.	N11.0.7A2	2 0 0									
		+	+	+	+	+	+	+	+	+	+
154.	N11.0.8A2	2 0 0									
		+	+	+	+	+	+	+	+	+	+
155.	N9A	2 2 0 0									
		+	+	+	+	+	+	+	+	+	+
156.	N10A	2 2 0 0									
		+	+	+	+	+	+	+	+	+	+
157.	N11A	2 1 0 0									
		+	+	+	+	+	+	+	+	+	+
158.	N12A	2 1 0 0									
		+	+	+	+	+	+	+	+	+	+
159.	ENDNODE										
		1	2	3	4	5	6	7			
		1234567890123456789012345678901234567890123456789012345678901234									

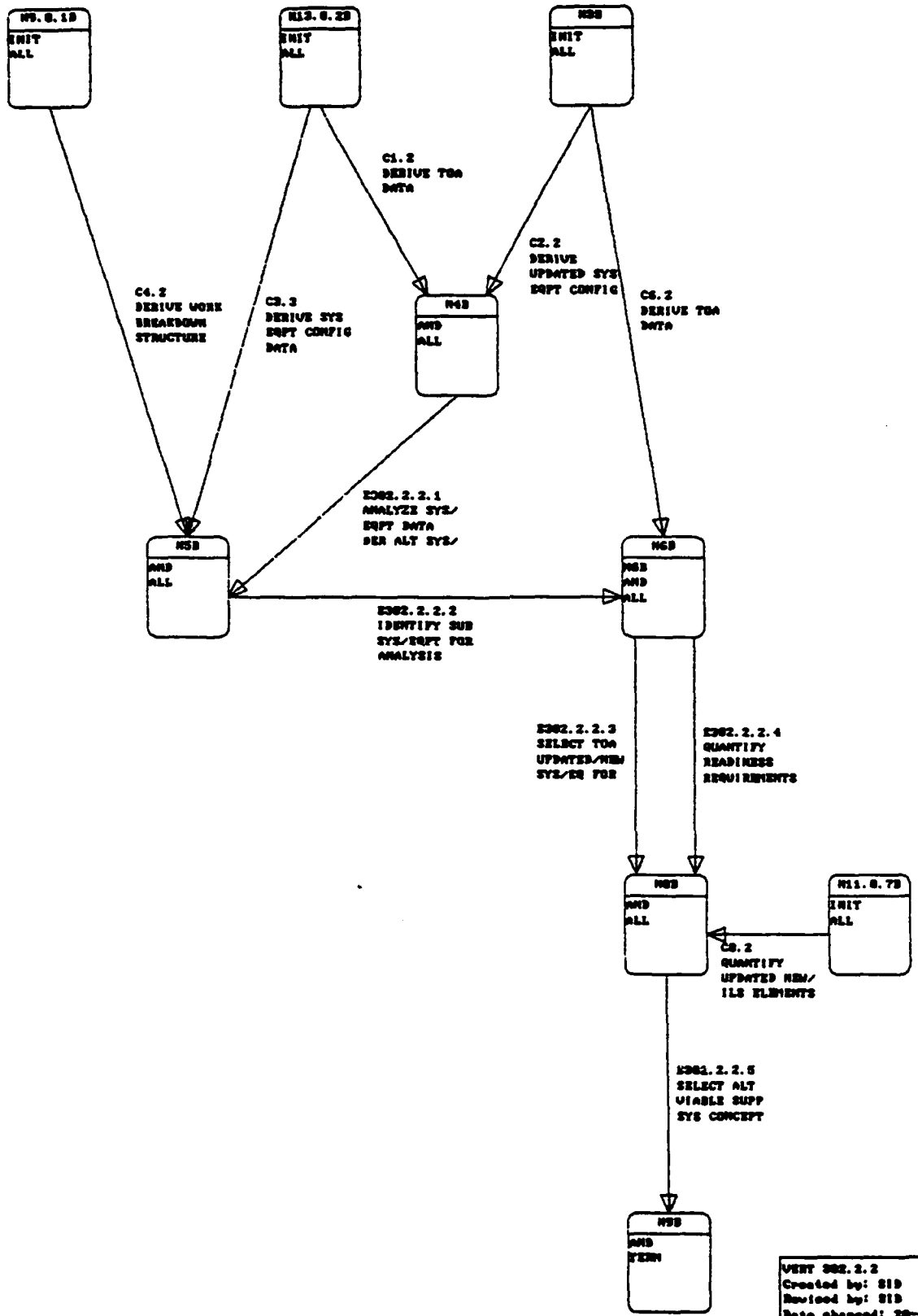

VERT 002.2.2
 Created by: SID
 Revised by: SID
 Date changed: 20-000-09

	1	2	3	4	5	6	7
1234567890123456789012345678901234567890123456789012345678901234							
1. 0016 10							
	+	+	+	+	+	+	+
2. C1.2	N13.0.2BN4B		1.0	DERIVE TRADEOFF ANALYSIS DATA			
3. C1.2	DTIME 1	2	10.0	20.0			
4. C1.2	DCOST 1	2	10.0	100.0			
5. C1.2	DPERF 1	2	10.0	50.0			
	+	+	+	+	+	+	+
6. C2.2	N3B N4B		1.0	DERIVE UPDATED SYSTEM EQUIPMENT CONFIGURATION			
7. C2.2	DTIME 1	2	10.0	20.0			
8. C2.2	DCOST 1	2	10.0	100.0			
9. C2.2	DPERF 1	2	10.0	50.0			
	+	+	+	+	+	+	+
10. C3.2	N13.0.2BN5B		1.0	DERIVE SYSTEM EQUIPMENT CONFIGURATION DATA			
11. C3.2	DTIME 1	2	10.0	20.0			
12. C3.2	DCOST 1	2	10.0	100.0			
13. C3.2	DPERF 1	2	10.0	50.0			
	+	+	+	+	+	+	+
14. C4.2	N9.0.1B N5B		1.0	DERIVE WORK BREAKDOWN STRUCTURE			
15. C4.2	DTIME 1	2	10.0	20.0			
16. C4.2	DCOST 1	2	10.0	100.0			
17. C4.2	DPERF 1	2	10.0	50.0			
	+	+	+	+	+	+	+
18. C5.2	N4B N5B		1.0	ANALYZE SYSTEM/EQPT DATA DERIVE ALTERNATE SYS.			
19. C5.2	DTIME 1	2	10.0	20.0			
20. C5.2	DCOST 1	2	10.0	100.0			
21. C5.2	DPERF 1	2	10.0	50.0			
	+	+	+	+	+	+	+
22. C6.2	N3B N6B		1.0	DERIVE TRADEOFF ANALYSIS DATA			
23. C6.2	DTIME 1	2	10.0	20.0			
24. C6.2	DCOST 1	2	10.0	100.0			
25. C6.2	DPERF 1	2	10.0	50.0			
	+	+	+	+	+	+	+
26. C7.2	N5B N6B		1.0	IDENTIFY SUB SYSTEM/EQUIPMENT FOR ANALYSIS			
27. C7.2	DTIME 1	2	10.0	20.0			
28. C7.2	DCOST 1	2	10.0	100.0			
29. C7.2	DPERF 1	2	10.0	50.0			
	+	+	+	+	+	+	+
30. C8.2	N11.0.7BN8B		1.0	QUANTIFY UPDATED NEW/ILS ELEMENTS			
31. C8.2	DTIME 1	2	10.0	20.0			
32. C8.2	DCOST 1	2	10.0	100.0			
33. C8.2	DPERF 1	2	10.0	50.0			
	+	+	+	+	+	+	+
34. C9.2	N6B N8B		1.0	SELECT TOA UPDATED/NEW SYS/EQPT FOR ANALYSIS			
35. C9.2	DTIME 1	2	10.0	20.0			
36. C9.2	DCOST 1	2	10.0	100.0			
37. C9.2	DPERF 1	2	10.0	50.0			
	+	+	+	+	+	+	+
38. C10.2	N6B N8B		1.0	QUANTIFY READINESS REQUIREMENTS			
39. C10.2	DTIME 1	2	10.0	20.0			
40. C10.2	DCOST 1	2	10.0	100.0			
41. C10.2	DPERF 1	2	10.0	50.0			
	+	+	+	+	+	+	+
42. C11.2	N8B N9B		1.0	SELECT ALTERNATE VIABLE SUPP SYS CONCEPT			
43. C11.2	DTIME 1	2	10.0	20.0			
44. C11.2	DCOST 1	2	10.0	100.0			
45. C11.2	DPERF 1	2	10.0	50.0			
	+	+	+	+	+	+	+

```

1
1234567890123456789012345678901234567890123456789012345678901234
NEW NETWORK PAGE 2
1234567890123456789012345678901234567890123456789012345678901234
46. ENDARC
47. N13.0.2B1 2 0 0
48. N4B 2 2 0 0
49. N3B 1 2 0 0
50. N5B 2 2 0 0
51. N9.0.1B 1 2 0 0
52. N6B 2 2 0 0
53. N11.0.7B1 2 0 0
54. N8B 2 2 0 0
55. N9B 2 1 0 0
56. ENDNODE
1234567890123456789012345678901234567890123456789012345678901234

```