

te technical note techn

AD-A258 216

2



Low Density Radio Communications Link (LDRCL) Operational Test and Evaluation (OT&E) Integration and Operational Test Plan

Wayne E. Bell
Michael R. Melillo
Tuan A. Tran
John Warren

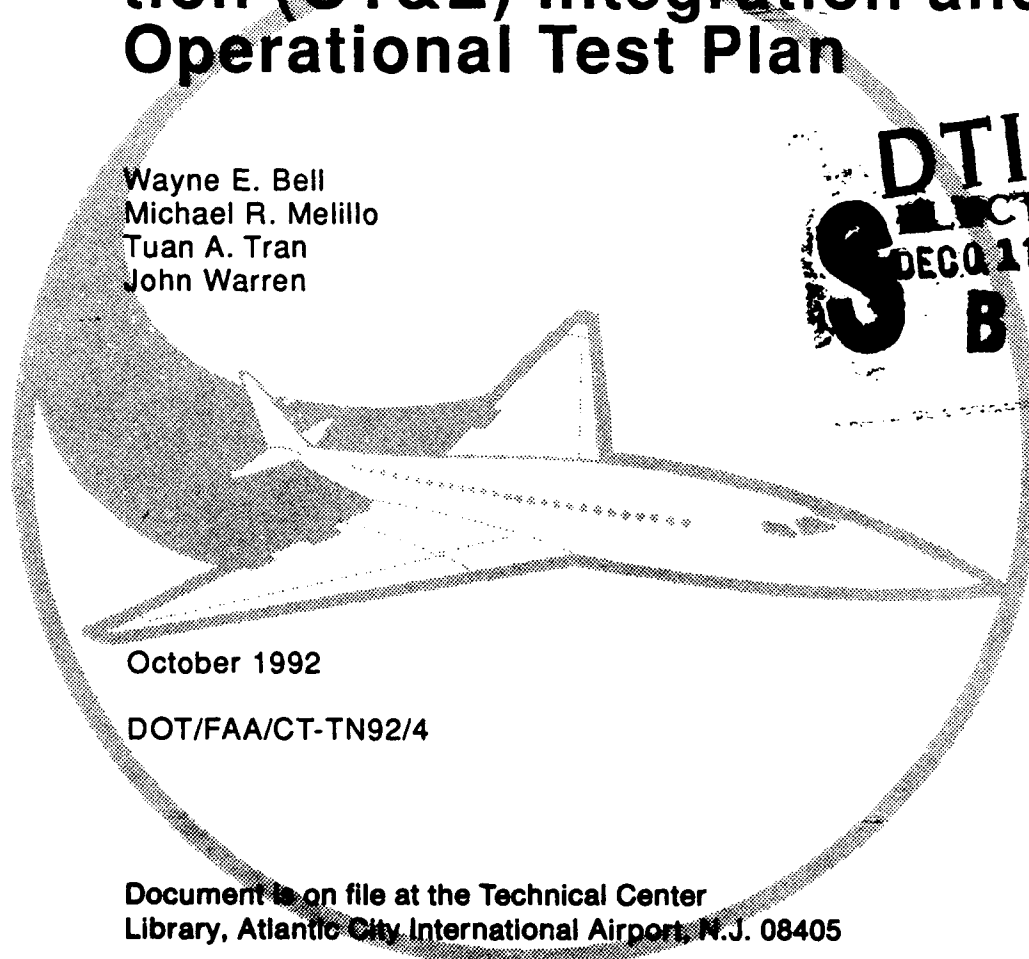

October 1992

DOT/FAA/CT-TN92/4

Document is on file at the Technical Center
Library, Atlantic City International Airport, N.J. 08405

92-30432



115PK



U.S. Department of Transportation
Federal Aviation Administration

Technical Center
Atlantic City International Airport, N.J. 08405

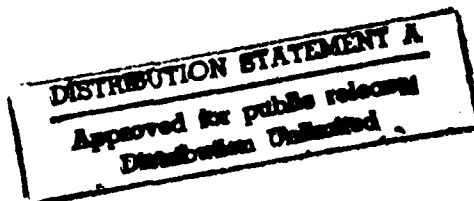

0 9

0 9

NOTICE

This document is disseminated under the sponsorship of the U.S. Department of Transportation in the interest of information exchange. The United States Government assumes no liability for the contents or use thereof.

The United States Government does not endorse products or manufacturers. Trade or manufacturers' names appear herein solely because they are considered essential to the objective of this report.

| | | | | | |
|---|--|--|--|--|-----------|
| 1. Report No. DOT/FAA/CT-TN92/4 | | 2. Government Accession No. | | 3. Recipient's Catalog No. | |
| 4. Title and Subtitle LOW DENSITY RADIO COMMUNICATIONS LINK (LDRCL) OPERATIONAL TEST AND EVALUATION (OT&E) INTEGRATION AND OPERATIONAL TEST PLAN | | | | 5. Report Date October 1992 | |
| | | | | 6. Performing Organization Code | |
| 7. Author(s) Wayne E. Bell, Michael R. Melillo, John Warren, ACN-260 | | | | 8. Performing Organization Report No. DOT/FAA/CT-TN92/4 | |
| 9. Performing Organization Name and Address Federal Aviation Administration Technical Center Atlantic City International Airport, NJ 08405 | | | | 10. Work Unit No. (TRAIS) | |
| | | | | 11. Contract or Grant No. | |
| 12. Sponsoring Agency Name and Address U.S. Department of Transportation Federal Aviation Administration Technical Center Atlantic City International Airport, NJ 08405 | | | | 13. Type of Report and Period Covered Technical Note | |
| | | | | 14. Sponsoring Agency Code | |
| 15. Supplementary Notes | | | | | |
| 16. Abstract This plan addresses the Operational Test and Evaluation (OT&E) Integration testing of the Low Density Radio Communications Link (LDRCL) equipment in the current National Airspace System (NAS) environment. The approach and concept is to conduct integration tests with appropriate NAS systems to verify that NAS requirements and LDRCL specifications (FAA-E-2853) requirements have been satisfied. This will be accomplished by conducting factory acceptance and site acceptance tests at the contractor's facility in Richardson, Texas, and extensive integration tests at the key sites of San Antonio, Texas; Scurry, Texas; and Mina, Nevada. | | | | | |
| 17. Key Words Microwave Radio Equipment Antenna Polarization Channel Capacity Digital Multiplex Equipment | | | | 18. Distribution Statement Document is on file at the Technical Center Library, Atlantic City International Airport, NJ 08405 | |
| 19. Security Classif. (of this report) Unclassified | | 20. Security Classif. (of this page) Unclassified | | 21. No. of Pages 110 | 22. Price |

TABLE OF CONTENTS

| | Page |
|--|------|
| EXECUTIVE SUMMARY | v |
| 1. INTRODUCTION | 1 |
| 1.1 Purpose | 1 |
| 2. REFERENCE DOCUMENTS | 1 |
| 3. TEST PHILOSOPHY | 2 |
| 3.1 Test Approach and Concept | 3 |
| 3.2 Program Flow Diagram | 4 |
| 3.3 Organizational Roles and Responsibilities | 4 |
| 4. NAS SYSTEM INTEGRATION TESTS | 4 |
| 4.1 OT&E Integration | 6 |
| 4.2 OT&E Operational | 8 |
| 4.3 OT&E Shakedown | 11 |
| 5. VERIFICATION OF NAS SYSTEM SPECIFICATION REQUIREMENTS | 11 |
| 5.1 Method of Verification | 11 |
| 6. TEST PROCEDURES | 12 |
| 6.1 Test Procedure Outline | 12 |
| 6.2 NAS System Performance Test Procedures | 12 |
| 7. TEST SCHEDULE | 13 |
| 8. DOCUMENTATION REQUIREMENTS AND CONTROL | 13 |
| 8.1 Master Test Plan (MTP) | 13 |
| 8.2 OT&E Integration and Operational Test Plan | 13 |
| 8.3 Test Procedures | 13 |
| 8.4 Test Log | 13 |
| 8.5 Test Discrepancy Report | 16 |
| 8.6 Final Test Report | 16 |
| 9. TRAINING | 16 |
| 10. TEST SUPPORT REQUIREMENTS | 17 |
| 10.1 Instrumentation | 17 |
| 10.2 Data Analysis | 17 |
| 10.3 Test Configuration | 18 |
| 10.4 Facility Requirements | 18 |

TABLE OF CONTENTS (Continued)

| | Page |
|--|------|
| 11. REVIEWS | 18 |
| 11.1 Weekly Status Reviews | 18 |
| 11.2 Monthly Status Review | 19 |
| 11.3 Pretest Review | 19 |
| 11.4 Post-Test Review | 19 |
| 11.5 Deployment Readiness Review (DRR) | 19 |

APPENDIXES

- A - NAS Operational Requirements TVRTM
- B - 1.8-GHz Digital System TVRTM
- C - 1.8-GHz Analog System TVRTM
- D - UHF System TVRTM
- E - 23-GHz Digital System TVRTM

LIST OF ILLUSTRATIONS

| Figure | | Page |
|--------|---|------|
| 1 | OT&E Test Effort | 3 |
| 2 | OT&E Integration and Operational Program Flow | 5 |
| 3 | OT&E Integration Test Activities | 7 |
| 4 | OT&E Operational Test Activities | 9 |
| 5 | LDRCL OT&E Test Schedule | 14 |
| 6 | Verification Documentation Hierarchy Tree | 15 |

EXECUTIVE SUMMARY

The LDRCL equipment being tested by this plan will be utilized to replace and upgrade existing link and leased systems not previously replaced under the Radio Communications Link (RCL) program. It will also satisfy new requirements for data communications of various National Airspace System (NAS) plan projects. The project will add additional facilities, and reconfigure the NAS Interfacility Communications System (NICS) by adding user access networks and providing interfaces with the RCL transmission facilities.

This plan, the Operational Test and Evaluation (OT&E) plan only addresses the part of OT&E that the Federal Aviation Administration (FAA) Technical Center is responsible for. The plan contains the schedule (figure 5). The test locations, defined under the NAS System Integration Test Section (section 4.0), and the type of testing required to prove that the equipment can successfully complete its mission, is found in (sections 4.1 and 4.2).

After successful completion of the OT&E effort, the FAA Technical Center can then provide a deployment recommendation in support of the Deployment Readiness Review (DRR).

DTIC QUALITY INSPECTED 2,

| | |
|----------------------|-------------------------------------|
| Accession For | |
| NTIS GRA&I | <input checked="" type="checkbox"/> |
| DTIC TAB | <input type="checkbox"/> |
| Unannounced | <input type="checkbox"/> |
| Justification | |
| <i>perform SO</i> | |
| By _____ | |
| Distribution/ | |
| Availability Codes | |
| Dist | Avail and/or Special |
| <i>A-1</i> | |

1. INTRODUCTION.

The Low Density Radio Communications Link (LDRCL) will be utilized to replace and upgrade existing link and leased systems not previously replaced by the high density Radio Communications Link (RCL) systems, and to satisfy new requirements for data communications of various National Airspace System (NAS) plan projects. It will allow for the lease and/or purchase, as required, of analog and digital link communications equipment. The project will add additional facilities, and reconfigure the NAS Interfacility Communications System (NICS) by adding user access networks and providing interfaces with the radio communications link transmission facilities.

1.1 PURPOSE.

The Operational Test and Evaluation (OT&E) Integration and Operational testing will ensure the Low Density Radio Communications Link (LDRCL) equipment is operationally suitable and effective in the National Airspace System (NAS) environment. This will be accomplished by ensuring the LDRCL equipment meets the operational requirements contained in the NAS System Specification and by verifying the LDRCL equipment can integrate successfully with existing NAS subsystems. The OT&E plan will delineate the responsibilities and overall planning to accomplish the OT&E testing in a timely manner. The Test Plan will establish test requirements which shall include general methods to conduct the test and criteria to evaluate the test's results.

2. REFERENCE DOCUMENTS.

FAA Specifications:

| | |
|------------|--|
| FAA-D-2494 | Technical Instruction Book Manuscript: Electronic, Electrical and Mechanical Equipment Requirements for Preparation of Manuscript and Production of Books |
| FAA-E-2853 | Low Density Radio Communications Link |
| FAA-E-2826 | Battery, Storage, Lead-Acid |
| FAA-G-1375 | Spare Parts - Peculiar for Electronic, Electrical and Mechanical Equipment |

FAA Standards:

| | |
|--------------|--|
| FAA-STD-013 | Quality Program Requirements |
| FAA-STD-019b | Lightning Protection, Grounding, Bonding, and Shielding Requirements for Facilities |
| FAA-STD-020a | Transient Protector, Grounding, Bonding and Shielding Requirements for Equipment |

FAA-STD-024a Preparation of Test and Evaluation Documentation

FAA-STD-028 Contract Training Programs

FAA Orders:

Order 1810.4B FAA NAS Test and Evaluation Policy

NAS Documents:

NAS-MD-110 Test and Evaluation (T&E) Terms and Definitions for the NAS

NAS-SS-1000 NAS System Specification, Functional and Performance Requirements for the NAS

DOD Documents:

DOD-D-1000 Drawing, Engineering and Associated Lists

DOD-STD-100 Engineering Drawing Practices

Other Documents:

EIA-RS-195 Electrical and Mechanical Characteristics for Microwave Relay System Antennas and Passive Reflectors

MIL-STD-1388-2 DOD Requirements for a Logistic Support Analysis

3. TEST PHILOSOPHY.

The OT&E is that phase of the testing conducted to verify system-level requirements (e.g., physical, functional, procedural, and NAS interface). The OT&E is comprised of Integration and Operational (OT&E Integration and Operational) testing for which ACW-400A is responsible and Shakedown testing for which ASM-600 is responsible. A block diagram of the OT&E test effort is shown in figure 1. This plan will only address the Integration and Operational efforts since ASM-600 will prepare a separate test plan for OT&E Shakedown. This plan will ensure that the following integration and operational activities are accomplished:

a. Review those requirements that were not successfully completed during Factory Acceptance Test (FAT) to determine if a retest is necessary;

b. Verify those requirements in appendix A, Operational Requirements TVRTM derived from NAS-SS-1000 and any of those requirements in appendices B, C, D, and E deemed necessary and identified by a "D" or "T" at the system or field level.

- c. Develop detailed OT&E Integration and Operational test procedures for those systems, subsystems, and equipment interfacing with the LDRCL systems;
- d. Conduct integration testing of the LDRCL systems as specified in this plan;
- e. Identify any problems encountered during OT&E verification;
- f. Provide test reports to the appropriate FAA organizations.

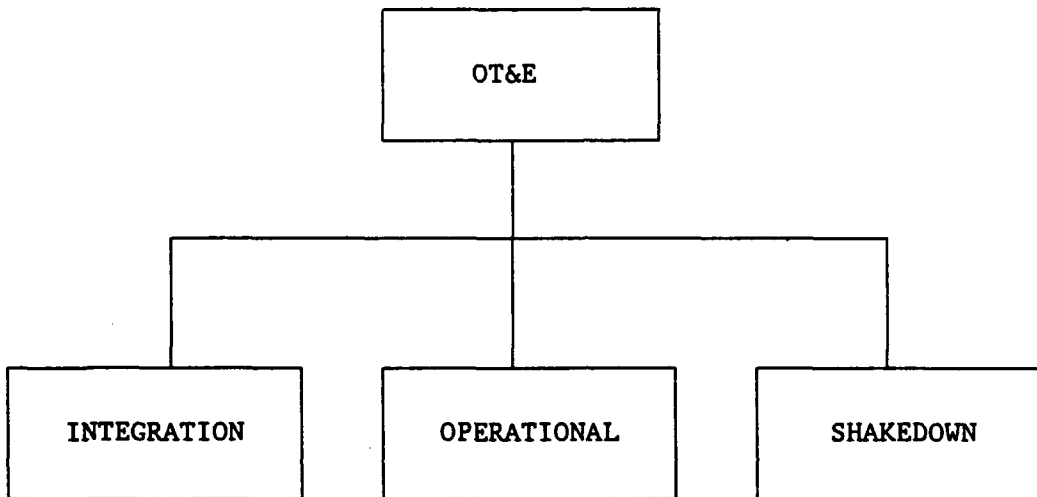

FIGURE 1. OT&E TEST EFFORT

3.1 TEST APPROACH AND CONCEPT.

The OT&E testing will be accomplished in a varied phase approach. The First Article of each system type will be subjected to a series of tests which will validate the system's ability to meet or exceed the requirements in the LDRCL Specification, FAA-E-2853. This phase will be accomplished by the contractor during DT&E/Qualifications (DT&E/Q), with test plans and procedures approved by the Federal Aviation Administration (FAA), and witnessed by the FAA Technical Center. Testing done during this period shall satisfy the requirements contained in TVRTMs in appendices C through E. After each LDRCL system type has completed DT&E/Q, each will be installed in one of the test sites that has been selected by the Program Office for OT&E testing. The selected test sites are Miami, Florida,

r the 1.8 GHz-digital system; Scurry, Texas, for the 1.8-GHz analog system; Mina, Nevada, for the UHF system; and Keller, Texas, for the 23-GHz system. During the second phase of testing, each LDRCL system will be tested sequentially. First, the system's ability to meet the operational requirements, contained in the NAS System Specification, are examined and evaluated. Second, the OT&E testing effort will ensure the LDRCL system types are operationally effective and suitable systems to be implemented into the NAS. This phase is accomplished by the FAA Technical Center.

The OT&E testing will primarily be accomplished at the four field sites mentioned above, however, testing with subsystems, not available at these test sites, may be performed at the FAA Technical Center.

2 PROGRAM FLOW DIAGRAM.

Program Flow Diagram for the OT&E Integration and OT&E Operational tests is shown in figure 2. This diagram shows the test effort for which ACW-400A is responsible. These tests will be followed by OT&E Shakedown, for which ASM-600 is responsible. ASM-600 will also prepare separate test plans and procedures. The activities which comprise OT&E Integration and OT&E Operational are described in the following sections.

3 ORGANIZATIONAL ROLES AND RESPONSIBILITIES.

The roles and responsibilities of the organizations participating in the LDRCL OT&E Integration test program are defined in Order 1810.4B, Part 3.

NAS SYSTEM INTEGRATION TESTS.

The NAS System Integration tests will be conducted in accordance with Order 1810.4B which divides OT&E tests into three areas: (1) OT&E Integration, (2) OT&E Operational, and (3) OT&E Shakedown. This test plan will describe OT&E Integration and OT&E Operational tests which are the responsibility of ACW-400A. ASM-640 is responsible for OT&E Shakedown and will write a test plan and test procedures for those tests.

NAS Integration tests will be conducted separately for each of the four LDRCL systems at four separate test sites.

- a. 1.8-GHz Digital System: This system will be the first system tested and will be installed in Miami, Florida.
- b. 1.8-GHz Analog System: This system will be the second system tested and will be installed in Scurry, Texas.
- c. UHF System: This will be the third system tested and will be installed in Mina, Nevada.
- d. 23-GHz Digital System: The fourth system will be installed in Keller, Texas.

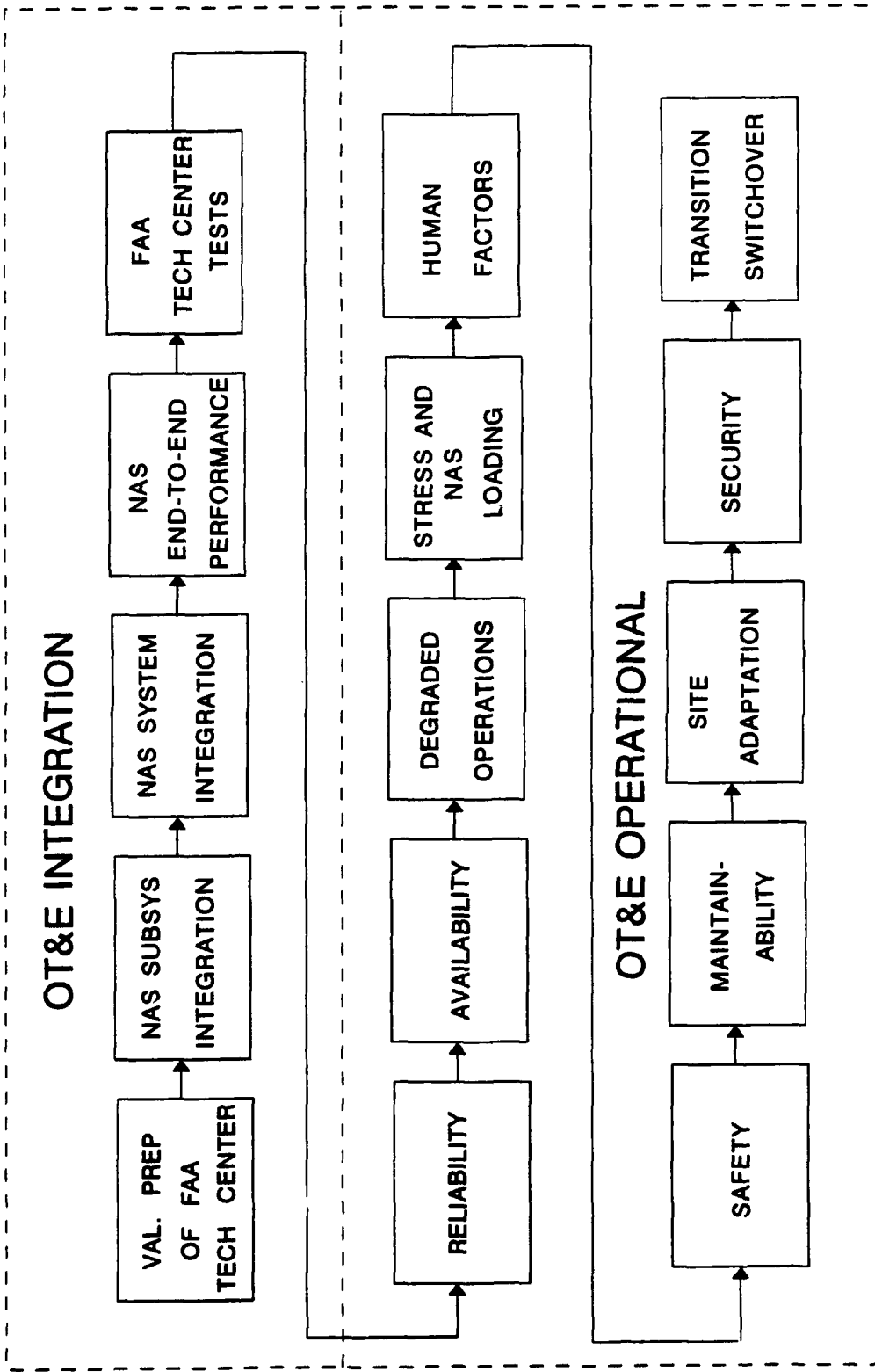

FIGURE 2. OT&E INTEGRATION AND OPERATIONAL PROGRAM FLOW

1 OT&E INTEGRATION.

The OT&E Integration consists of testing NAS System End-to-End Performance. Specifically, this is testing NAS-SS-1000, Volume I, (System Level) and Volumes II through V subsystem level requirements as identified in the project's Federal Aviation Administration (FAA) Master Test Plan (MTP) Verification Requirements Acceptability Matrices (VRTM). This testing establishes NAS baseline performance (end-to-end), or verifies that previously existing NAS performance has not been degraded. To the greatest extent possible, the subsystem will test in a NAS system equivalent environment. This test effort is shown in figure 3.

OT&E Integration is comprised of the following test areas:

- a. Validate Preparation of FAA Technical Center
- b. NAS Subsystem Integration
- c. NAS System Integration
- d. NAS End-to-End Performance
- e. FAA Technical Center Tests (if required)

Each of these test activities is described in the following section.

1.1 Validate Preparation of FAA Technical Center.

This area of testing verifies that the FAA Technical Center has been suitably prepared to accept installation of the LDRCL systems.

1.2 NAS Subsystem Integration.

These tests will ensure that the LDRCL subsystem can meet subsystem requirements when communicating over a microwave link. These tests will be selected tests from the Site Acceptance tests, if deemed necessary, and the tests listed below. These tests encompass all LDRCL systems. Only those tests applicable to the appropriate LDRCL system will be conducted.

- a. Envelope Delay Distortion
- b. Frequency Translation and Level
- c. Channel Amplitude Frequency
- d. Phase and Jitter
- e. VF Circuit Performance
- f. Automatic Network Monitoring System (ANMS) to LDRCL Interface
- g. Backup Radio Channel
- h. Modem to LDRCL
- i. Minimum Useable Signal
- j. Bit Error Rate
- k. Stress Pattern
- l. Harmonic Distortion
- m. Emissions
- n. LDRCL to RCL Interface
- o. High Power Amplifier (except 23-GHz system)
- p. Space Diversity
- q. Amplitude Response
- r. System Linearity
- s. Baseband Performance

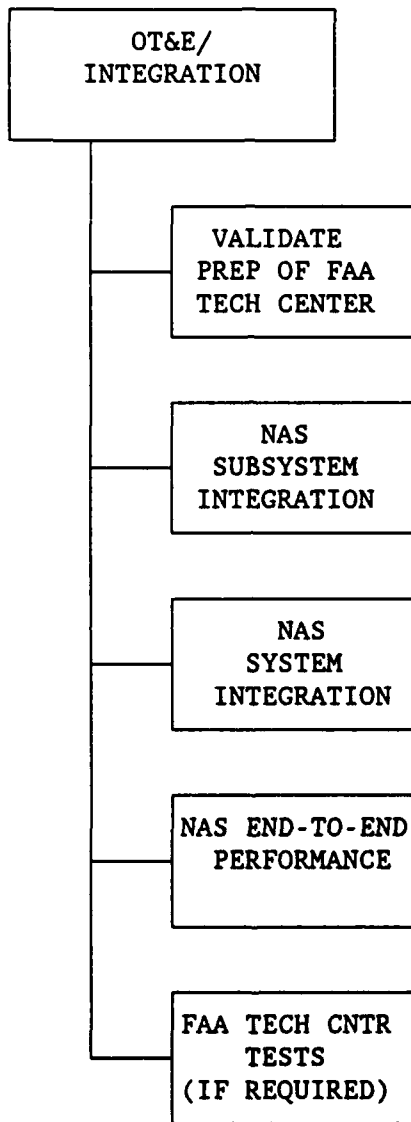

FIGURE 3. OT&E INTEGRATION TEST ACTIVITIES

4.1.3 NAS System Integration.

This area of testing will ensure that the LDRCL systems can interface properly with other NAS subsystems.

4.1.4 NAS End-To-End Performance.

This area of testing would normally verify System Level Requirements as defined in NAS-SS-1000. Since LDRCL requirements are not presently defined in NAS-SS-1000, Operational Requirements derived from NAS-SS-1000, and shown in appendix A, will be used. These tests cover such areas as audio quality, crosstalk, alarms, facility integration and backup channel tests. Parallel traffic tests and tests with live data will also be conducted.

4.1.5 FAA Technical Center Tests.

Testing at the FAA Technical Center will be conducted, if required, for those interfacing systems not available at the selected test sites.

4.2 OT&E OPERATIONAL.

The OT&E Operational testing has the intent of proving the operational effectiveness and suitability of the equipment with user participation in the evaluation testing. Aspects of this testing are listed below and shown in figure 4.

- a. Reliability
- b. Availability
- c. Degraded Operations
- d. Stress and NAS Loading
- e. Human Factors
- f. Safety
- g. Maintainability
- h. Site Adaptation Data
- i. Security
- j. Transition Switchover

A description of each of these activities is provided in the following sections.

4.2.1 Reliability.

Test and Evaluation to determine the ability of the system to operate with the specified power without failure over the full range of power conditions. A detailed power test and/or evaluation is essential on at least one type/model of equipment. These tests do not substitute for power tests conducted during Production Acceptance Test and Evaluation (PAT&E), whether in-plant or on-site as part of Installation and Checkout.

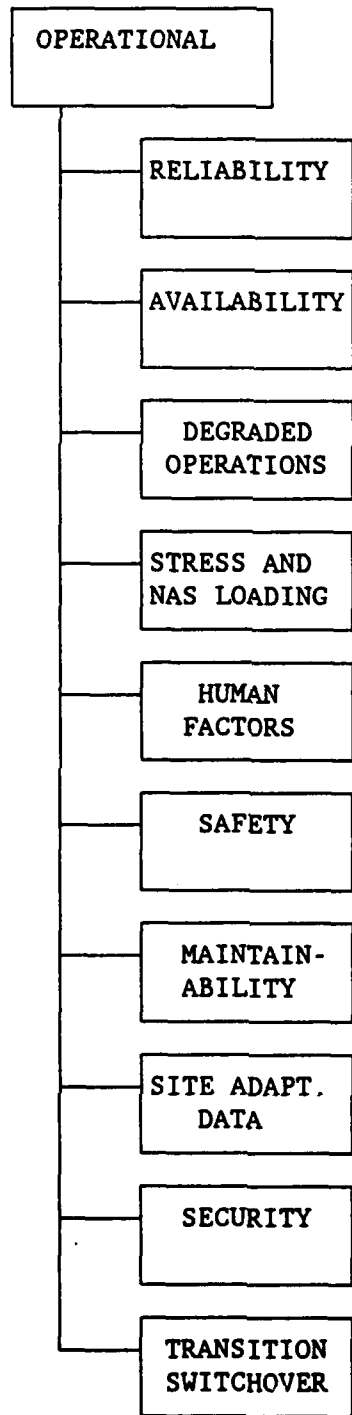

FIGURE 4. OT&E OPERATIONAL TEST ACTIVITIES

4.2.2 Availability.

The probability that an item will be operationally ready to perform its function when called upon at any point in time. Steady state availability of installed equipment is a function of equipment Mean-Time-Between-Failures (MTBF) and equipment down time (MDT) as follows:

$$A = \text{MTBF}/(\text{MTBF} + \text{MDT})$$

The probability that a system will be available may also be stated for identified degradation levels.

4.2.3 Degraded Operations.

Tests conducted to determine the acceptability of the initiation/termination procedures and the acceptability of the resultant operational degradation when failures are introduced in the system. This includes validation of shutdown procedures (manual/automatic), startup procedures, degraded operations procedure, and operational impact of the data preservation/integrity function.

4.2.4 Stress and NAS Loading.

This test will evaluate the system under a fully stressed and loaded condition.

4.2.5 Human Factors.

Test and Evaluation to estimate and/or determine the degree to which the interaction of personnel with the system in the operational environment is accommodated. This will explore such factors such as:

- a. the physical interaction of personnel with a system,
- b. interactions with procedures,
- c. physical and psychological responses to training, workloads, and logistic programs,
- d. operational environments.

4.2.6 Safety.

Test and Evaluation conducted to assess whether the design meets the specified safety requirements for personnel and equipment (i.e., high voltage protection, circuit protection, grounding, radiation, etc.).

4.2.7 Maintainability.

A measure of the ease and rapidity with which the system can be restored to operational status following a failure, expressed as the probability that an item will be retained in or restored to a specified condition within a given period of time when the maintenance is performed in accordance with prescribed procedures and resources.

4.2.8 Site Adaptation Data.

Test and Evaluation to determine the degree to which the software and/or hardware used for the development, update, and installation of operational site adaptation data (software or firmware) meets specified requirements.

4.2.9 Security.

Test and Evaluation conducted to assess the degree to which the design will result in a system that allows only authorized access/use.

4.2.10 Transition Switchover.

Tests to estimate and/or determine that the system and procedures are such that a move from the old system to the new or vice versa can be accomplished without degrading NAS operations while minimizing impact on the user.

4.3 OT&E SHAKEDOWN.

To be provided by ASM-640.

5. VERIFICATION OF NAS SYSTEM SPECIFICATION REQUIREMENTS.

Although LDRCL is not specified in the NAS SS-1000, it is classified as transmission equipment. Therefore, the NAS system requirements for transmission equipment that are appropriate for LDRCL will be verified during this phase.

5.1 METHOD OF VERIFICATION.

Four types of verification methods will be used to ensure that the LDRCL equipment meets performance requirements. The methods of verification are defined below:

a. **TEST (T)** Test is defined as a method of verification wherein performance requirements are verified by measurement during or after controlled applications of functional and/or environmental stimuli. Quantitative measurements are analyzed to determine the degree of compliance. These measurements may require the use of laboratory equipment, recorded data, procedures, items, and services.

b. **DEMONSTRATION (D)** Demonstration is defined as a method of verification denoting the qualitative determination of properties of an end-item including software and/or the use of technical data and documentation. The items being observed are visually demonstrated but not qualitatively measured, in a dynamic state.

c. **ANALYSIS (A)** Analysis is defined as a method of verification by comparing hardware design with known scientific and technical principles, procedures, and practices to estimate the capability of the design to meet the mission and system requirements.

d. **INSPECTION (I)** Inspection is defined as a method of verification wherein the requirement is visually examined.

6. TEST PROCEDURES.

Detailed test procedures will be written by ACW-400A with technical inputs from key test site personnel, for all OT&E Integration and OT&E Operational tests. ASM-640 will write test procedures for OT&E Shakedown tests.

6.1 TEST PROCEDURE OUTLINE.

All test procedures will follow the outline given below:

1. INTRODUCTION
 - 1.1 TEST OBJECTIVE
 - 1.2 BACKGROUND
 - 1.3 EQUIPMENT DESCRIPTION
2. TEST APPROACH
3. TEST REQUIREMENTS
 - 3.1 NAS REQUIREMENTS (NAS-SS-1000, VOLUME IV)
 - 3.2 RMMS/MPS REQUIREMENTS (NAS-MD-790)
4. TEST EQUIPMENT REQUIRED
5. TEST SEQUENCE
6. DATA COLLECTION
 - 6.1 DATA REDUCTION AND ANALYSIS
7. TEST RESPONSIBILITIES
8. TEST SCHEDULE

6.2 NAS SYSTEM PERFORMANCE TEST PROCEDURES.

Tests in this area will evaluate how well the LDRCL systems interface with the NAS systems at the key field sites. The only systems known to be interfaced at this time include;

- a. 1.8-GHz Digital System, Miami, Florida;
ASR-9 to TRACON; 7 or 8 Channels
- b. 1.8-GHz Analog System, Scurry, Texas;
RCAG to RCL DIP, 4 Channels
- c. UHF, Mina, Nevada;
RCAG to Beacon; VORTAC to Modem; 1 Circuit

RCAG to Modem; 2 Circuits
- d. 23-GHz Digital, Keller, Texas
LRR to RCL DIP

7. TEST SCHEDULE.

The OT&E test schedule is given in figure 5. Note that this schedule is only applicable to one system. The same sequence of events, however, will be followed for the remaining LDRCL systems.

8. DOCUMENTATION REQUIREMENTS AND CONTROL.

This section describes the required documents for planning, conducting, and reporting the LDRCL OT&E activities. Figure 6 illustrates the necessary LDRCL verification documentation.

8.1 MTP.

The purpose of the MTP is to provide overall guidance for the Test and Evaluation (T&E) program of the LDRCL. The MTP will describe the testing activities that should take place to ensure the LDRCL can be successfully integrated into the NAS.

8.2 OT&E INTEGRATION AND OPERATIONAL TEST PLAN.

The purpose of the OT&E Integration and Operational test plan is to establish the specific tests, objectives, schedules, resources, requirements, test methodology, and delineate the responsibilities and overall planning to accomplish the OT&E Integration testing in a timely manner.

8.3 TEST PROCEDURES.

Test procedures are in the process of being written and will be published in a separate document. These procedures will be distributed to the Southwest and Western Pacific Regions, where the test sites are located, for their comments.

8.4 TEST LOG.

The test log will contain entries from each and every test conducted. One log book will be established for each one of the LDRCL systems. Entries will be made at the start, during, and at the completion of every test conducted. Entries will include time, date, and any relevant information about the test including all discrepancies. The test support group will be responsible for the log and will insure that it is properly completed.

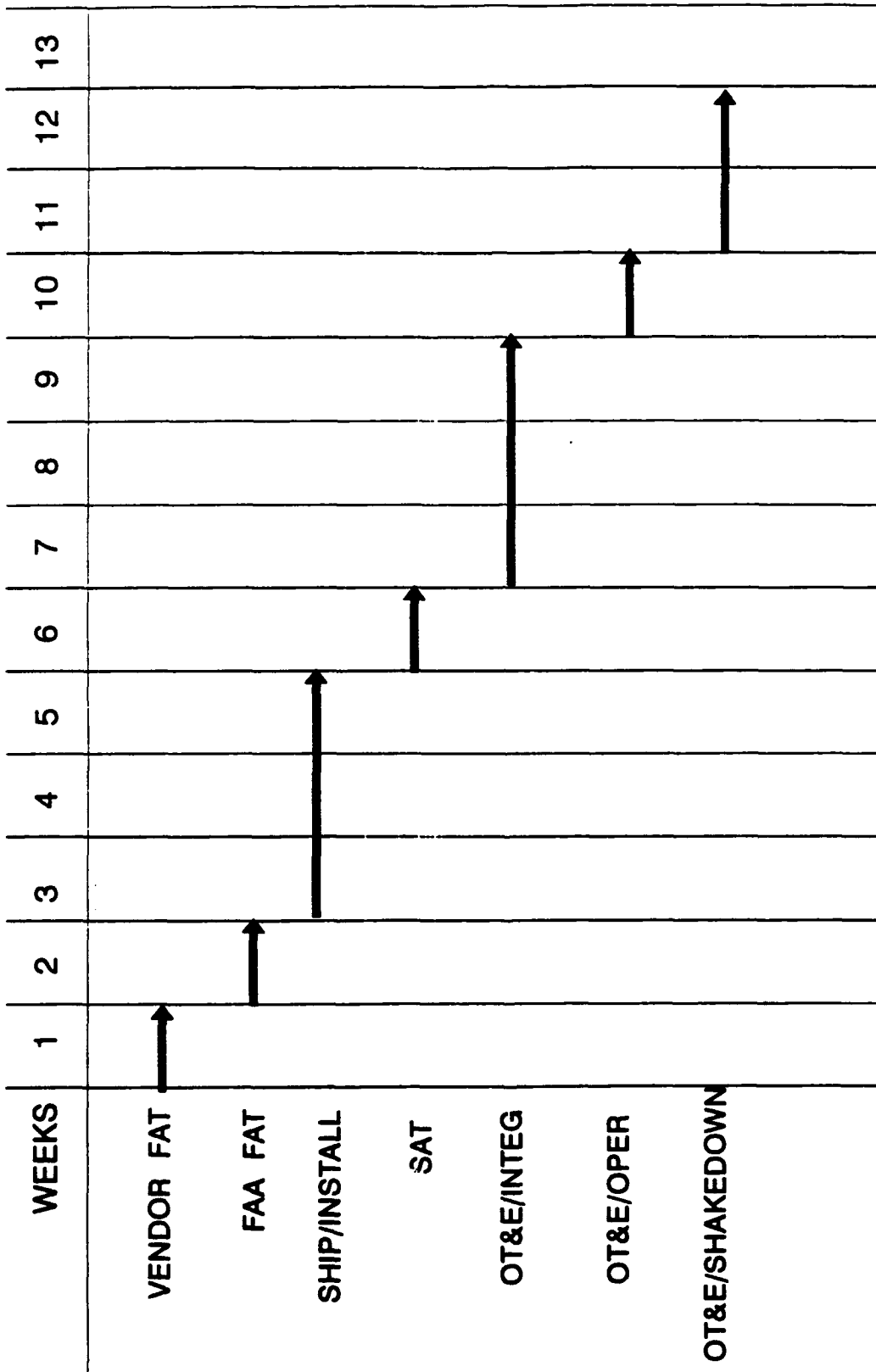

FIGURE 5. LDRCL OT&E TEST SCHEDULE

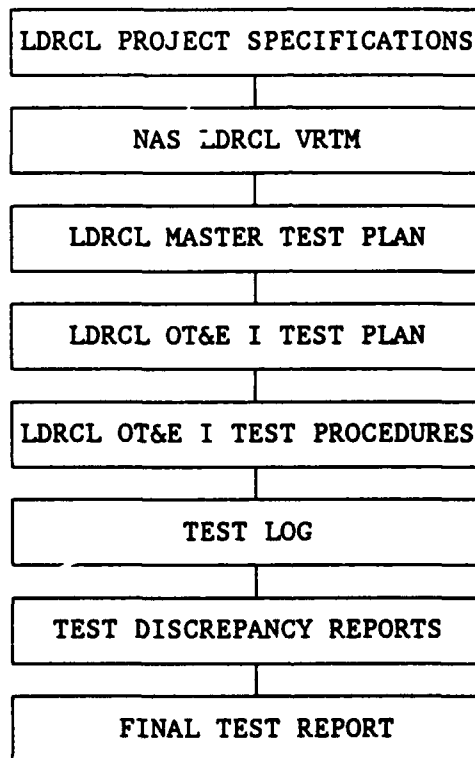

FIGURE 6. VERIFICATION DOCUMENTATION HIERARCHY TREE

8.5 TEST DISCREPANCY REPORT.

The responsible test coordinator as identified by the Test Director will ensure that all test discrepancies are properly documented. The following forms shall be used to document test discrepancies.

- a. Hardware Discrepancy Report, (HDR) FAA Form 6030-3, is initiated when a problem is hardware related.
- b. Program Technical Report, (PTR) FAA Form 6100-1, is issued to report program problems/improvements.
- c. NAS System Support Facility Trouble Report, CT Form 6100-29, is initiated when a problem is related to a maintenance-type discrepancy.

8.6 FINAL TEST REPORT.

A final test report will be written and forwarded to all appropriate organizations. This report will document test results of the LDRCL T&E verification program. The test coordinator, as identified by the Test Director, will be responsible for formulating the final test report.

The final test report will include information obtained from all recorded data, to include but not be limited to, the test logs, test observations, discrepancy reports, and test evaluations. At a minimum, the final test report will include:

- a. Evaluation of any operational impacts which will include a list of all problems and/or concerns found during testing.
- b. Identification of any outstanding problems.
- c. All problems that have been resolved and those that have not.
- d. All test results both positive and negative.

A final test report will be published for each individual LDRCL system type no later than 30 days after the completion of the OT&E/Integration and Operational testing.

9. TRAINING.

All personnel working on the LDRCL T&E program that will be conducting tests will, at a minimum, be required to complete the FAA's Common Microwave Communications Link Principles Course #44321-2 or have equivalent working experience. In addition, test personnel will read all test equipment manuals to become familiar with the equipment to the degree that guarantees safe operation of the test equipment. All test procedures will be written in order that minimal specialized training will be required to perform LDRCL OT&E Integration tests.

Any specialized training needed for the operation of LDRCL radio equipment shall be provided by the contractor and will be outlined in the contractor's training plan.

10. TEST SUPPORT REQUIREMENTS.

The contractor shall identify and supply any unique test equipment, tools, test cable, and extender boards that are required to perform maintenance on the LDRCL equipment. Unique is defined as any item that is normally required for tests and adjustments and is only available from the contractor. The government shall provide all other necessary test equipment needed to perform the LDRCL OT&E Integration tests.

10.1 INSTRUMENTATION.

The following items or their equivalents have been identified by the government to be special equipment that may not be available at key sites and will be necessary during OT&E Integration. The Program Office should make arrangements to have this equipment available during testing at the key sites.

- a. Scientific Atlanta, Model 4683, Radio Performance Analyzer
- b. Hewlett Packard, Model 3787B, Digital Data Test Set
- c. Hewlett Packard, Model 4945 Transmission Impairment Measuring Set (TIMS) (Qty 2)
- d. Hewlett Packard, Model 5348A, Counter/Power Meter
- e. Hewlett Packard, Model 5351B, Microwave Frequency Counter
- f. Hewlett Packard, Model 8592B, Spectrum Analyzer
- g. Hewlett Packard, Model 3400A, RMS Voltmeter
- h. TTC, Firebird 6000, T1 Test Set
- i. IFR, Model AM/FM 500, Service Monitor
- j. Wescom, Model 3617-00, Signaling Test Modem
- k. Anritsu, Model ME453/M, Microwave System Analyzer

10.2 DATA ANALYSIS.

It shall be the responsibility of the test support group to collect and analyze the data obtained during the LDRCL OT&E Integration tests performed at the key sites. The criteria used to determine the success of the test shall be defined in the test procedures. If quantitative results are expected, then upper and lower limits will be provided in the test procedure and used as pass/fail criteria. If qualitative results are expected, then detailed explanations of required test observations shall be provided in the test procedures and used as pass/fail criteria. Data shall be collected during the tests and forms shall be provided in every test procedure. The data will be available for review in the final test report and it will be the responsibility of the Test Director to distribute the test report to the appropriate organizations.

0.3 TEST CONFIGURATION.

All LDRCL OT&E Integration tests that can be accomplished will be accomplished at even key sites selected by the program office. Refer to the LDRCL MTP for the location of the key sites and the equipment types that will be tested at each. Any configurations or interface types not tested at the key sites will be tested at the FAA Technical Center. The following buildings will be used for this testing and will contain the systems noted:

Building 156 - 4 different LDRCL terminal stations and their associated repeaters. (UHF, 1.8-GHz Analog, 1.8-GHz Digital, and the 23-GHz Digital system).

Building 223 - One 23-GHz Digital Terminal Station

Building 223 - One 1.8-GHz Analog (48-channel) system

Building 269 - One 1.8-GHz Digital Terminal Station

Building 196 - One UHF Analog Terminal Station

Building 162 - One 1.8-GHz Analog Terminal Station

The LDRCL radio equipment shall be installed and tested Field Site Acceptance Test (FSAT) performed in these facilities by the contractor in the same manner as in the field.

0.4 FACILITY REQUIREMENTS.

All facilities used for LDRCL OT&E Integration and Operational testing must have grounding systems that conform to FAA-STD-019a. The electrical service must meet local and National Electrical Code (NEC) codes for safety and proper installation. The ceiling height in the rooms where LDRCL equipment will be installed must be of sufficient height to accommodate the LDRCL radio equipment and the overhead waveguide connections. The floor in these rooms must be able to withstand the loading of the radio equipment. The air conditioning and ventilation must be sufficient to overcome the heat dissipated by the radio equipment. At each facility location there should be a tower of sufficient height to give the LDRCL a viable path to the next site.

1. REVIEWS.

The following identifies the types of reviews that will occur during the LDRCL OT&E integration process.

1.1 WEEKLY STATUS REVIEWS

These reviews will serve to keep the LDRCL test support group informed as to the status of the OT&E program. These meetings will serve as a way that technical information on the tests may be discussed. The test plan, test procedures, and scenarios will be reviewed at these meetings.

11.2 MONTHLY STATUS REVIEW.

These reviews will serve to keep the LDRCL test management group informed as to the overall status of OT&E Integration activities. The test plan, test schedule, and monthly progress will be reviewed in these meetings.

11.3 PRETEST REVIEW.

These reviews will be chaired by the test coordinator immediately before testing, and will establish the readiness for conducting and witnessing a formal test. The review will include a status of prerequisites, software, and system equipment needed to complete the test or series of tests. The procedure for conducting the test will be presented and any deviations will be addressed. The test support group must be in agreement on all changes before testing may begin.

11.4 POST-TEST REVIEW.

These reviews will be chaired by the test coordinator after a test has been completed. The full test team will attend and the test log will be made available as a reference. During the meeting a review of the results of the test activity and anomalies will be discussed and noted. An assessment of the quality of the test will be made and the impact of problems encountered will be addressed.

11.5 DEPLOYMENT READINESS REVIEW (DRR).

DRRs are prepared, scheduled, and conducted in accordance with the NAS Plan Projects Deployment Readiness Review Process. The DRR process reviews all the LDRCL project activities, identifies open issues and enables the formulation of conclusions and recommendations to these issues. The DRR also ensures that adequate attention and resources are focused on these issues to ensure timely resolution prior to deployment.

APPENDIX A

NAS OPERATIONAL REQUIREMENTS TVRTM

Test Verification Requirements Traceability Matrix (TVRTM)
Operational User's Requirements

| DESCRIPTION OF VERIFICATION REQUIREMENT | TEST IMPLEMENTATION | |
|--|---------------------|--------|
| | OT&E/I | OT&E/S |
| 1. Verify that the audio quality of any circuit does not become degraded, and that there is no detectable change in voice quality/level as the LDRCL is accessed by the signals to and from the RCL links. | D | |
| 2. Verify that crosstalk is not detectable under maximum loading of the LDRCL paths. | D | |
| 3. Verify that the alarm indicators function properly under electrical transients caused by commercial power changes. | D | D |
| 4. Verify that after system failure in LDRCL, the entire path can be restored in thirty minutes(maintainability) | D | |
| 5. Verify that the removal/replacement of any line replaceable unit (LRU) does not affect the normal operation of the LDRCL. | D | |
| 6. Verify that adequate spare parts exist at each site to support urgent repairs to the LDRCL. | | D |
| 7. Verify that the LDRCL can be integrated with existing FAA facility power and environmental systems with little or no impact on normal operations. | | D |
| 8. Verify that the LDRCL can protect itself from the effects of power outages, fluctuations and harmful transients. | | D |
| 9. Verify that the LDRCL, in the process of accessing the circuits of the RCL paths, will not take down any other specified, critical circuits that would not otherwise have been affected by the problem. | D | |

LEGEND: T-TEST; D-DEMONSTRATION; A-ANALYSIS; I-INSPECTION

(Note: If any of the above tests are done during DT&E, and witnessed by the FAA Technical Center, they need not be repeated during OT&E).

Test Verification Requirements Traceability Matrix (TVRTM)
Operational User's Requirements

| DESCRIPTION OF VERIFICATION REQUIREMENT | TEST IMPLEMENTATION | |
|--|---------------------|--------|
| | OT&E/I | OT&E/S |
| 10. Verify by random sampling the mechanical and electrical interchangeability among assemblies, sub-assemblies, and LRUs that are supposed to be identical. | | D |
| 11. Verfiy that the LDRCL is not affected by electromagnetic radiation and does not affect other FAA systems with EMI. | D/T | |

T-TEST; D-DEMONSTRATION; A-ANALYSIS; I-INSPECTION

(Note: If any of the above tests are done during DT&E, and witnessed by the FAA Technical Center, they need not be repeated during OT&E).

APPENDIX B

1.8-GHz DIGITAL SYSTEM TVRTM

LDRCL TVRTM
1.8-GHz DIGITAL SYSTEM

| FAA-E-2853 | TITLE | LEVEL AND METHOD | | | REMARKS |
|------------|---|------------------|--------|-------|---------|
| | | UNIT | SYSTEM | FIELD | |
| 3.1.2.1 | DUTY CYCLE - CAPABLE OF CONTINUOUS OPERATION | A | A | X | |
| 3.1.2.2 | AMBIENT TEMPERATURE - OPERATE WITHIN SPEC OVER FOLLOWING RANGE : 0 DEG C TO +50 DEG C | D | A | X | |
| 3.1.2.3 | RELATIVE HUMIDITY - OPERATE WITHIN SPEC OVER FOLLOWING RANGE : 95% AT 40 DEG C WITHOUT CONDENSATION | D | A | X | |
| 3.1.2.4 | POWER - ALL EQUIP EXCLUDING BATTERY CHARGER OPERATE WITHIN SPEC WITH INPUT OF -24 VDC (-21 TO -28 VDC) OR -48 VDC (-42 TO -54 VDC) WITH A MAXIMUM RIPPLE OF 300mv - BATTERY CHARGER TO OPERATE AT 120 VOLTS +/-10%, 60 Hz AC +/-2%. | D | A | X | |
| 3.1.2.5 | RACKS - EQUIP INSTALLED INDOORS MOUNTED IN STD 19" OR 23" RACKS, NO MORE THAN 7' TALL - BATTERY CHARGER MOUNTED IN ACCORDANCE WITH 3.8 - ALL CONNECTIONS WITHIN 7' RACK - BATTERY CHARGER WALL OR RACK MOUNTED - BATTERIES MOUNTED IN STD BATTERY RACKS, EXCEPT AS AN OPTION, EARTHQUAKE RESISTANT FREE STANDING RACKS PROVIDED AT LOCATIONS WHERE ORDERED BY GOVERNMENT - TOP ACCESS FOR EXTERNAL CABLES, BOTTOM ACCESS WHEN ORDERED BY GOVT. - ALL EQUIP PROVIDED WITH REMOVABLE DUST COVERS OR OTHER METHODS TO PREVENT DUST ON COMPONENT PARTS - ALL WIRING WITHIN NATIONAL ELECTRIC CODE | I | I | X | |

LDRCL TVRTM
1.8-GHz DIGITAL SYSTEM

| FAA-E-2853 | TITLE | LEVEL AND METHOD | | | REMARKS |
|------------|---|------------------|--------|-------|---------|
| | | UNIT | SYSTEM | FIELD | |
| 3.1.2.7 | SOLID STATE - USE ONLY SOLID STATE FOR ACTIVE COMPONENTS, EXCEPT FOR RELAYS, SWITCHES AND METERS | I | I | I | |
| 3.1.2.8 | ACCESSIBILITY - EQUIP CONSTRUCTED SO THAT EACH MODULE AND SUBASSEMBLY IS EASILY ACCESSIBLE. - MODULE AND SUBASSEMBLY MOUNTED TO TO PERMIT REPLACEMENT WITHOUT REMOVAL OF OTHER MODULES OR SUBASSEMBLIES. - RACK CABLING ARRANGED SO THAT EQUIP CAN BE REMOVED AND INSERTED WITHOUT DAMAGE TO EQUIP OR CABLING. - UNUSED MUX SHELF POSITIONS WIRED NOT EQUIPPED AND CONNECTORIZED - MOST OF MAINTENANCE ACCOMPLISHED FROM FRONT | I | I | I | |
| 3.1.2.9 | TRANSIENT PROTECTION, GROUNDING, BONDING AND SHIELDING - IN ACCORDANCE WITH FAA-E-019 AND FAA-E-020. | I | I | I | |
| 3.1.2.10 | FINISHES - IN ACCORDANCE WITH CONTRACTOR COMMERCIAL STANDARDS | I | I | I | |
| 3.1.2.11 | COOLING - CONVECTION COOLING FOR MOST OF THE SYTSTEM - FORCED AIR TO EXTEND SERVICE LIFE WITH AIR FLOW MONITOR AND ALARM TO DETECT FAILURE OF AIR FLOW | I | I | I | |
| 3.1.2.12 | INTER-CHANGEABILITY - CKT CARDS, PWR SUPPLIES, MODULES AND OTHER ASSEMBLIES OF THE SAME TYPE AND MANUFACTURE INTERCHANGEABLE AND INTEROPERABLE. | D | A | X | |

LDRCL TVRTM
1.8-GHz DIGITAL SYSTEM

| FAA-E-2853 | TITLE | LEVEL AND METHOD | | | REMARKS |
|------------|--|------------------|--------|-------|---------|
| | | UNIT | SYSTEM | FIELD | |
| 3.1.2.13 | SPECIAL EQUIPMENT - IDENTIFY AND SUPPLY ANY SPECIAL/ UNIQUE TEST EQUIP, TOOLS, CABLES AND EXTENDER CARDS REQUIRED FOR TEST AND ADJUSTMENT AND ONLY AVAIL- ABLE FROM CONTRACTOR. | I | I | I | |
| 3.2 | REQUIRED CHARACTERISTICS | | | | TITLE |
| 3.2.1 | GENERAL - ALL EQUIP COMMERCIALY AVAILABLE OFF-THE-SHELF. - IN ACCORDANCE WITH REQUIREMENTS - MEET ALL RQMTS WHEN ASSEMBLED INTO CONFIG FOR FIELD INSTALLATION. | I | T | X | |
| 3.2.2 | MICROWAVE RADIO EQUIPMENT | | | | TITLE |
| 3.2.2.1 | SPECTRUM DESIGN REQUIREMENTS - XMITTERS AND RCVRs IN ACCORDANCE RQMTS OF NTIA MANUAL. - DESIGNED FOR EFFICIENT USE OF SPECTRUM | D | X | I | |
| 3.2.2.2 | FREQUENCY AND ANTENNA POLARIZATION ASSIGNMENTS - PROVIDE FREQ AND ANT POLARIZATION ASSIGNMENT CRITERIA. - INCLUDE ALL NECESSARY DATA FOR SYSTEM OPERATION IN CONGESTED AREAS - INCLUDE INTERMOD, LOCAL OSC, IMAGE FREQ AND ALL OTHER CONSIDERATIONS TO ALLOW FREQ ASSIGNMENTS FOR SYS OPERATION IN ACCORDANCE WITH SPEC. - PROVIDE INFO TO ALLOW GOVT TO CHANGE FREQ WITHIN OPERATING BAND. | D | D | I | |
| 3.2.3 | EQUIPMENT CONFIGURATION - RADIO EQUIP CONFIGURED FOR HOT STANDBY OPERATION WITH FAULT SENS- ING AND NOISE SQUELCH CIRCUITRY AT ALL STATIONS. | X | T | T | |

LDRCL TVRTM
1.8-GHz DIGITAL SYSTEM

| FAA-E-2853 | TITLE | LEVEL AND METHOD | | | REMARKS |
|-------------------|--|------------------|--------|-------|---------|
| | | UNIT | SYSTEM | FIELD | |
| 3.2.3 (CONT'D) | <ul style="list-style-type: none"> - SATISFY SPEC IN ANY CONFIGURATION ORDERED. - METHOD FOR SENSING FAILURES IN ACTIVE CHANNEL AND AUTOMATICALLY SWITCHING TO STANDBY CHANNEL - MONITOR STANDBY CHAN TO DETECT AND ALARM FAILURES TO PREVENT SWITCHING TO FAILED CHANNEL - PERMIT NORMAL ACTIVE CHAN OPERATION DURING MAINT ON STANDBY CHANNEL. - 10E-06 BER SWITCHING FOR DIGITAL SYSTEMS | | | | |
| 3.2.4 | RADIO FREQUENCY (RF) COUPLER <ul style="list-style-type: none"> - COUPLER WITH 30 dB FORWARD ATTN - MOUNTED NEAR TOP OF RACK | I | I | I | |
| 3.2.5 | RADIO FREQUENCY CONNECTORS <ul style="list-style-type: none"> - HIGH QUALITY, HIGH FREQUENCY, TYPE N, SMA, OR WAVEGUIDE | I | I | I | |
| 3.2.6 | ANTENNAS <ul style="list-style-type: none"> - LIGHTWEIGHT GRID FOR MOST APPLICATIONS - SOLID PARABOLIC DISHES WHERE REQUIRED - ANTENNAS, MOUNTS AND HARDWARE PER SPEC AND IN ACCORDANCE WITH STANDARDS RECOMMENDED IN EIA RS-195 | I | X | I | |
| 3.2.7 | TRANSMISSION LINE <ul style="list-style-type: none"> - UNPRESSURIZED FOAM COAX BETWEEN XMITTER/RCVR OUTPUT/INPUT PORTS AND ANTENNA UNLESS PATH DESIGN CRITERIA DICTATES OTHERWISE - PRESSURIZED SYSTEMS EQUIPPED WITH MAINTENANCE FREE AIR DRYER - LOW PRESSURE ALARM FOR AIR PRESSURE - ALARM FOR MONITORING SYSTEM - FOUR PORT MANIFOLD | I | X | I | |

LDRCL TVRTM
1.8-GHz DIGITAL SYSTEM

| FAA-E-2853 | TITLE | LEVEL AND METHOD | | | REMARKS |
|------------|---|------------------|--------|-------|---------|
| | | UNIT | SYSTEM | FIELD | |
| 3.2.8 | RECEIVER COMBINER/SWITCH - NOT CAUSE INTERRUPTIONS OR TRANS- IENTS WHICH DEGRADE SIGNAL - NO LOSS OF DIGITAL DATA DUE TO AUTOMATIC COMBINER/SWITCH ACTION - NO ACTIVE ELEMENTS COMMON TO BOTH CHANNELS - PERMIT NORMAL SYSTEM OPERATION WITH EITHER PATH DISABLED DUE TO EQUIP FAILURE OR MAINTENANCE - NOT EFFECT TRANSMISSION IN OPPOSITE DIRECTION - FAULT SENSING CKT INDICATE WHICH CHANNEL IS ACTIVE | T | T | T | |
| 3.2.9 | MULTIPLEXING EQUIPMENT - CAPABLE OF MUXING UP TO 8 DS-1 CHAN - CHAN CAPACITY AS ORDERED BY GOVT COMPLETE WITH CHAN BANKS & EQUIP REQD AT BOTH TERM ENDS TO INTERFACE WITH 4-WIRE VF & E&M ANALOG CKTS OR DS-1 LEVEL DATA STREAMS - EXTENDED SUPERFRAME FORMAT FOR DS1 - ADDITIONAL CHANNEL CARDS <ol style="list-style-type: none"> a. 4W E&M/ER b. 4W E&M/PLR/ER c. 4W TO/ER | T | T | T | |
| 3.2.9.1 | REDUNDANT CONFIGURATION - FULLY REDUNDANT AT CHAN BANK LEVEL WITH HOT STANDBY REDUNDANT CHANNEL BANK COMPONENTS FOR NO INTERRUPTION IN SERVICE FOR MORE THAN ONE CHAN | X | T | T | |
| 3.2.9.2 | MONITOR AND TEST CAPABILITY - INCORPORATE BUILT-IN DIAGNOSTICS TO INCLUDE INDIVIDUAL DS-1 LOOPBACK TESTING AND BER MONITORING | T | T | T | |
| 3.2.10 | ORDER WIRE SERVICE CHANNEL | | | | |

LDRCL TVRTM
1.8-GHz DIGITAL SYSTEM

| FAA-E-2853 | TITLE | LEVEL AND METHOD | | | REMARKS |
|------------|--|------------------|--------|-------|---------|
| | | UNIT | SYSTEM | FIELD | |
| 3.2.10.1 | GENERAL - WHEN ORDERED PROVIDE SINGLE LINK PARTY LINE CHANNEL AT ALL STATIONS - OPERATE INDEPENDENTLY OF MUX EQUIP | X | D | D | |
| 3.2.10.2 | AUXILIARY FUNCTIONS - EQUIPPED WITH OPERATOR HEADSET PLUGGED INTO FRONT PANEL - PROVIDED WITH INTEGRAL SIGNALING - LOUDSPEAKER PROVIDED FOR MONITORING | X | D | D | |
| 3.2.11 | JACK FIELDS - BANTAM JACKS FOR ANALOG TESTING AND PATCHING - DSX-1 JACKFIELDS FOR TESTING AND PATCHING AT A DS1 LEVEL - SEPARATE DIGITAL JACKFIELD | I | I | I | |
| 3.2.12 | RF SPLITTER - STANDARD CONFIG 3:3 dB COUPLER - OPTIONAL 1:10 dB FOR 1.8 DIGITAL SYSTEM | I | I | I | |
| 3.2.13 | LINE CONDITIONING EQUIPMENT - ATTENUATION DEVICES TO PROVIDE UP TO 23 dB OF ATTENUATION, LOCATED CLOSE TO MULTIPLEX EQUIPMENT | I | T | T | |
| 3.3 | PARAMETERS FOR 1.8 GHz SYSTEM | | | | |
| 3.3.1 | FREQUENCIES OF OPERATION FOR 1.8 GHz EQUIPMENT - RADIO EQUIP OPERATE IN 1700-1850 AND 2200-2300 MHz BANDS - OPERATE ANYWHERE WITHIN BAND IN ACCORDANCE WITH CCIR RECOMMENDATION 283-4. | T | T | X | |
| 3.3.3 | RF POWER - MIN XMIT POWER ONE HALF WATT AT XMITTER EQUIP OUTPUT PORT. - HIGH POWER XMITTER OPTION AVAILABLE | T | T | T | |

LDRCL TVRTM
1.8-GHz DIGITAL SYSTEM

| FAA-E-2853 | TITLE | LEVEL AND METHOD | | | REMARKS |
|-------------------|---|------------------|--------|-------|---------|
| | | UNIT | SYSTEM | FIELD | |
| 3.3.3 (CONT'D) | - HIGH POWER OPTION INCREASE POWER TO AT LEAST ONE WATT WITH PROVISION FOR AT LEAST FIVE WATTS - 3 WATT OPTION FOR DIGITAL RADIOS | | | | |
| 3.3.4 | TRANSMITTER FREQUENCY STABILITY - BETTER THAN +/-0.001% OVER SPEC REQUIREMENT RANGE FOR 1.8 DIGITAL SYSTEM - BETTER THAN +/-0.0005% OVER SPEC REQUIREMENT RANGE FOR 1.8 ANALOG SYSTEM | T | T | T | |
| 3.3.5 | CHANNEL CAPACITY - INHERENT LOW DISTORTION AND INTRINSIC NOISE CHARACTERISTICS FOR TRANSMITTING UP TO EIGHT DS-1 CHANNELS OR UP TO 132 ANALOG VOICE CHANNELS | I | I | I | |
| 3.3.6 | TRANSMITTER FAULT SENSING - PROVIDE SENSING TECHNIQUE FOR FAILURES AND ALARM OUTPUT - MONITOR XMITTER PARAMETERS : a. XMITTER PWR BELOW PRESET LEVEL b. SIGNAL CONTINUITY THRU MODULATION CKTS TO OUTPUT OF LAST ACTIVE ELEMENT IN XMITTER CKTS | T | T | T | |
| 3.3.7 | RECEIVER FAULT SENSING - PROVIDE SENSING TECHNIQUE FOR FAILURES AND ALARM OUTPUT - MONITOR RECEIVER PARAMETERS : a. UNCORRECTED BIT ERRORS b. SIGNAL CONTINUITY THRU ALL RCVR DEMOD CKTS FROM RCVR INPUT TO LAST ACTIVE ELEMENT | T | T | T | |
| 3.3.8 | RECEIVER NOISE FIGURE - MAX NOISE FIGURE OF 5.0 dB | D | T | L | |

LDRCL TVRTM
1.8-GHz DIGITAL SYSTEM

| FAA-E-2853 | TITLE | LEVEL AND METHOD | | | REMARKS |
|------------|---|------------------|--------|-------|---------|
| | | UNIT | SYSTEM | FIELD | |
| 3.3.10 | IF AMPLIFIER - IF CENTER FREQ OF 35 OR 70 MHz | T | X | X | |
| 3.3.13.1 | RECEIVER SQUELCH - RCVR EQUIPPED WITH AIS CIRCUIT INITIATED BY SYSTEM BIT ERROR RATE OF APPROXIMATELY 10E-4 - SQUELCH NOT ACTIVATED WITH MINOR SIGNAL VARIATIONS | T | T | T | |
| 3.3.13.3 | RECEIVER THRESHOLD - 1 DS-1 AND 4 DS-1 RADIO, AT 10E-06 BER, THE RECEIVER THRESHOLD IS ≤ -78.5 dBm - 8 DS-1 RADIO, AT 10E-06 BER, THE RECEIVER THRESHOLD IS ≤ -75.5 dBm | T | T | T | |
| 3.3.13.4 | SYSTEM SENSITIVITY - PROVIDE BER OF LESS THAN 10E-06 WITH RCVR OPERATING AT SPECIFIED THRESHOLD LEVEL - BER LESS THAN 10E-03 WITH RCVRs 2dB BELOW SPECIFIED THRESHOLD LEVEL | T | T | T | |
| 3.3.13.5 | DIGITAL MULTIPLEX EQUIPMENT - PROVIDE CAPABILITY FOR UP TO EIGHT DS-1 CHANNELS - FRONT PANEL JACKS FOR TESTING AND PATCHING - IN ACCORDANCE WITH 3 2.9 | T | T | T | |
| 3.3.13.5.1 | NARROWBAND DIGITAL MULTIPLEX EQUIP - OPTIONALLY CAPABLE OF MUXING ONE DS-1 CHAN (24 VOICE CHAN EQUIV) WITH OCCUPIED BANDWIDTH NOT TO EXCEED 1.6 MHz - EXPANDABLE TO 4 DS-1'S | T | T | T | |
| 3.6 | REMOTE MONITORING/SENSING - PROVIDE REMOTE MONITORING/SENSING AT TERMINAL STATIONS THAT PROVIDE ALARM STATUS FOR ALL STATIONS | I | I | I | |

LDRCL TVRTM
1.8-GHz DIGITAL SYSTEM

| FAA-E-2853 | TITLE | LEVEL AND METHOD | | | REMARKS |
|-----------------|---|------------------|--------|-------|---------|
| | | UNIT | SYSTEM | FIELD | |
| 3.6 (CONT'D) | <ul style="list-style-type: none"> - POLLING DEVICE PROVIDED FOR SYSTEMS WITHOUT ACCESS TO ACORN - DEVICE POLLS, STORES AND COLLECTS ALARMS - ACORN COMPATIBLE | | | | |
| 3.6.1 | <p>REPORTED ALARMS</p> <ul style="list-style-type: none"> - MINIMUM ALARMS : <ul style="list-style-type: none"> a. XMITTER PARAMETERS b. RCVR PARAMETERS c. PRIMARY POWER FAILURE d. BATTERY CHARGER FAILURE e. LOW DC VOLTAGE ALARM f. MULTIPLEX EQUIP ALARM g. LOW TRANSMISSION LINE PRESSURE h. OBSTRUCTION LIGHT FAILURE * i. BLDG INTRUSION ALARM * j. MIN OF 2 ADDITIONAL UNASSIGNED * k. ACTIVE/STANDBY MICROWAVE CHANNEL STATUS ALARM * GOVT PROVIDE INPUT FOR THIS ALARM (DRY CONTACT- GND & OPEN CKT) | T | T | T | |
| 3.6.2 | <p>ALARM INDICATION</p> <ul style="list-style-type: none"> - PROVIDE CAPABILITY OF REPORTING FAILURES BY AUDIO & VISUAL ALARMS - ALARMS FOR HIGH/LOW OPER PERF - ALARMS POINTS CONNECTED TO CONNECTORIZED TERMINAL BLOCK - CAPABILITY TO INTERFACE WITH EXTERNAL ALARM MONITORING SYSTEM - COMPATIBLE WITH RCL ANMS - ALARMS NOT REMOTED TO RCL ARE COLLECTED AND TERMINATED AT SITE DESIGNATED BY THE GOVERNMENT - MEANS TO SILENCE AUDIBLE ALARM WITH VISUAL ALARM ACTIVE UNTIL FAULT CLEARED - AUDIBLE ALARM TO REACTIVATE FOR ADDITIONAL ALARMS | T | T | T | |

LDRCL TVRTM
1.8-GHz DIGITAL SYSTEM

| FAA-E-2853 | TITLE | LEVEL AND METHOD | | | REMARKS |
|-------------------|---|------------------|--------|-------|---------|
| | | UNIT | SYSTEM | FIELD | |
| 3.6.2 (CONT'D) | - ALARM INDICATION TO INCLUDE STATION IDENTIFIER, TIME, TYPE, STATUS AND ANY OTHER INFO TO ALLOW QUICK CORRECTIVE ACTION | | | | |
| 3.6.2.1 | ALARM INTERFACE WITH RCL SYSTEM -TABS - PROVIDE RACK MOUNTED CONNECTIVITY POINT FOR ACORN INTERFACE - PROVIDE BLOCKS FOR ABOVE | T | T | T | |
| 3.6.3 | REMOTE CONTROLS - CAPABILITY TO ALLOW SELECTION OF MAIN/STANDBY EQUIP AND FOUR EXTERNAL FUNCTIONS FROM A REMOTE LOCATION | T | T | T | |
| 3.7.1 | RELIABILITY - MTBA NOT LESS THAN 10,000 HRS | A | A | X | |
| 3.7.2 | MAINTAINABILITY - MAXTTR NO MORE THAN 30 MIN | A | A | X | |
| 3.7.3 | AVAILABILITY - NOT LESS THAN 99.99% | A | A | X | |
| 3.8.1 | BATTERIES - BATTERY COMPLEMENT WITH STANDARD BATTERY RACKS CAPABLE OF OPERATING AT -24 VOLTS OR -48 VOLTS - MADE UP OF INCREMENTS TO SUSTAIN MAX CONFIGURATION FOR MIN OF 8 HRS - BATTERY CAPACITIES SIZED IN 4 HR INCREMENTS FROM MIN OF 8 HRS TO MAX OF 24 HRS - BATTERIES AND RACKS MEET FAA-E-2826 TYPE I, CLASS 2, STYLE A - SPECIAL APPLICATIONS, 30 MINUTE BATTERY BACKUP | I | X | I | |
| 3.8.1.1 | BATTERY PROTECTION - LOW VOLTAGE DISCONNECT AT 1.75 VOLTS PER CELL | X | T | T | |

LDRCL TVRTM
1.8-GHz DIGITAL SYSTEM

| FAA-E-2853 | TITLE | LEVEL AND METHOD | | | REMARKS |
|---------------------|--|------------------|--------|-------|---------|
| | | UNIT | SYSTEM | FIELD | |
| 3.8.1.1 (CONT'D) | <ul style="list-style-type: none"> - REMOTE CONTROL OF LOW VOLTAGE DISCONNECT - LOCAL AND REMOTE OVERRIDE OF LOW VOLTAGE DISCONNECT FUNCTION - AUTOMATIC RESET OF LOW VOLTAGE DISCONNECT WHEN BATTERIES REACH FULL CHARGE - TRANSIENT PROTECTION | | | | |
| 3.8.2 | <p>BATTERY CHARGER</p> <ul style="list-style-type: none"> - BATTERY CHARGER TO PROVIDE 1:1 REDUNDACY TO SUPPORT SITE LOAD AND BATTERY RATING - CHARGERS RATED AT 25, 50, 75, 100, 150, 200, OR 250 AMPS PROVIDE POWER FOR INSTALLED SYSTEM - VOLTAGES -24 OR -48 VDC - SINGLE POINT OF FAILURE ELIMINATED - SIZED TO CHARGE BATTERIES IN 3.8.1 TO AT LEAST 90% BASED ON A 1:3 RATIO RECHARGE TIME WHILE ALSO POWERING EQUIPMENT - FULLY AUTOMATIC - AUTOMATIC CHARGING CIRCUITRY TO SWITCH FROM FLOAT TO HIGH RATE WITH RECTIFIER OPERATING IN CURRENT LIMITING FOR PREDETERMINED TIME - SETABLE TIMER OR SENSING CKT TO TIME LIMIT HIGH RATE OF CHARGE - HARMONIC CONTENT OF INPUT CURRENT CAUSED BY EQUIP NOT EXCEED 5% OF 60 Hz AND NO SINGLE HARMONIC >5% UNDER LINEAR LOAD CONDITIONS - OVERLOAD PROTECTION INCLUDED IN CHARGER - INPUT POWER FACTOR WITHIN 0.8 LAG TO UNITY WHEN OPERATED FROM 50 TO 100% RATED OUTPUT LOAD - INCLUDE A LOAD DISTRIBUTION POWER PANEL - COPPER GROUND BUSS BAR - RACK MOUNTED | T | T | L | |

LDRCL TVRTM
1.8-GHz DIGITAL SYSTEM

| FAA-E-2853 | TITLE | LEVEL AND METHOD | | | REMARKS |
|------------|---|------------------|--------|-------|---------|
| | | UNIT | SYSTEM | FIELD | |
| 3.8.2.1 | OPTIONAL BATTERY CHARGER SYSTEM - USED FOR A MINIMUM BACKUP PERIOD - PROVIDES POWER UNTIL MOTOR GENERATOR PROVIDE POWER - RECTIFIER/CHARGER RACK MOUNTED AND OPERATING AT -24 VDC OR -48 VDC | T | X | T | |
| 3.8.3 | SPACE DIVERSITY - OPTION FOR 1.8 GHz - PROVIDE ALL EQUIP INCLUDING SEPARATE ANTENNA SYSTEM FOR STBY RCVR - SPACE DIVERSITY RECEIVER SWITCHES ON BIT ERROR RATE - SPACE DIVERSITY RECEIVER IDENTICAL TO NON SPACE DIVERSITY RECEIVER | T | T | T | |
| 3.8.4 | TOWERS - CONFORM TO EIA/TIA-222-E - WHEN LIGHTING IS REQUIRED PROVIDE A TOWER LIGHT FAILURE ALARM THAT INTERFACES WITH THE ANMS | I | X | D | TITLE |
| 3.8.4.1 | OBSTRUCTION LIGHTS - LIGHTS FOR TOWERS > 200 FEET - 20,000 CANDLE POWER FOR DAY AND TWILIGHT HOURS, 2,000 CANDLE POWER FOR NIGHT HOURS | A | A | I | |
| 3.8.5 | ANTENNA MOUNTS - DETERMINED BY PATH ANALYSIS - PROPOSED IN SITE PREPARATION PLAN | A | A | I | |
| 3.8.6 | GROUNDING SYSTEM - PROVIDE AIR TERMINALS, DOWN CONDUCTORS, FASTENERS, CLAMPS, ETC WITH EACH TOWER | X | X | T | |
| 3.9.1 | DRAWINGS, PARTS LIST AND COURSE MATERIALS - SITE INSTALLATION DRAWINGS PROVIDED IN HARDCOPY AND MAGNETIC MEDIA - ENG DWGS IN ACCORDANCE WITH MIL-T-31000 PARAGRAPH 3.6.4 | I | X | X | |

LDRCL TVRTM
1.8-GHz DIGITAL SYSTEM

| FAA-E-2853 | TITLE | LEVEL AND METHCD | | | REMARKS |
|-------------------|--|------------------|--------|-------|---------|
| | | UNIT | SYSTEM | FIELD | |
| 3.9.1 (CONT'D) | <ul style="list-style-type: none"> - COURSE MATERIAL IN ACCORDANCE WITH FAA-STD-028A - PARTS LISTS IN HARD COPY USED FOR PROVISIONING FORMATTED IN ACCORD WITH FAA-G-1375 - PARTS LIST FOR LSA IN ACCORDANCE WITH MIL-STD-1388-2A | | | | |
| 3.9.2 | INSTRUCTION BOOKS <ul style="list-style-type: none"> - 2 COMPLETE SETS FOR EACH STATION - BOOK FOR EACH EQUIP IN ACCORDANCE WITH FAA-D-2494 AND CONTAIN <ul style="list-style-type: none"> a. GENERAL INFO AND RQMTS b. TECHNICAL DESCRIPTION c. OPERATION d. CORRECTIVE AND PREVENTIVE MAINT e. INSTALL, INTEG AND CHECKOUT f. PARTS LIST g. SCHEMATIC DIAGRAMS IN ACCORDANCE WITH DOD-STD-100 h. CKT DIAGRAMS WITH DESCRIPTIONS | I | X | I | |
| 3.10.2.1 | SITE SPARES <ul style="list-style-type: none"> - PROVIDE RECOMMENDED QUANTITY OF SITE LRU'S TO SATISFY AVAILABILITY REQUIREMENTS - PROVIDE ALL REQUIRED SITE SPARES | X | X | I | |
| 3.10.2.2 | DEPOT PARTS-PECULIAR <ul style="list-style-type: none"> - PROVIDE IN ACCORDANCE WITH FAA-G-1375 | X | X | I | |
| 4.2 | UNIT TESTS <ul style="list-style-type: none"> - CONDUCT FACTORY TESTS ON EACH SUB-ASSEMBLY IN SYSTEM - TESTS DEMONSTRATE NORMAL OPERATING TOLERANCES PER EQUIP DOCUMENTATION, SPEC AND CONFIGURATION CONTROL DOC. | T | X | X | |
| 4.3 | SYSTEM TESTS <ul style="list-style-type: none"> - CONDUCT SYSTEM END-TO-END TESTS ON FIRST SYSTEM OF EACH TYPE | X | T | X | |

LDRCL TVRTM
1.8-GHz DIGITAL SYSTEM

| FAA-E-2853 | TITLE | LEVEL AND METHOD | | | REMARKS |
|-----------------|---|------------------|--------|-------|---------|
| | | UNIT | SYSTEM | FIELD | |
| 4.3 (CONT'D) | <ul style="list-style-type: none"> - TESTS DEMONSTRATE NORMAL OPERATION PER EQUIP DOC, SPEC, INSTRUCTION BOOKS AND CONFIGURATION CONTROL DOC - ALL OTHER SYSTEMS TESTED AT RACK LEVEL AT A MIN | | | | |
| 4.4 | FIELD TESTS <ul style="list-style-type: none"> - CONDUCT FIELD SYSTEM END-TO-END PERFORMANCE ACCEPTANCE TESTS ON INSTALLED SYSTEMS - TESTS DEMONSTRATE NORMAL OPERATION PER EQUIP DOCUMENTATION, SITE INSTALLATION PLAN, SPEC, INSTRUCTION BOOK AND CONFIGURATION CONTROL DOC. - TESTS DEMONSTRATE THAT PROPAGATION PATH OPERATING WITHIN 3dB OF CALCULATED VALUE | X | X | T | |
| 5.0 | PREPARATION FOR DELIVERY <ul style="list-style-type: none"> - IN ACCORDANCE WITH BEST COMMERCIAL PRACTICES - ALASKA AND HAWAII SHIPPED THROUGH DEFENSE TRANSPORTATION SYSTEM | I | I | X | |
| 6.0 | PREPARATION FOR INSTALLATION <ul style="list-style-type: none"> - SITE PREP CONFORMS TO NATIONAL ELECTRICAL CODE, LOCAL CODES AND EIA INSTALLATION STANDARDS - NEW CONSTRUCTION CONFORMS TO FAA-STD-032 | X | X | I | |

NOTES:

- T - TEST
- D - DEMONSTRATION
- I - INSPECTION
- A - ANALYSIS
- X - NOT APPLICABLE

APPENDIX C

1.8-GHz ANALOG SYSTEM TVRTM

LDRCL TVRTM
1.8-GHz ANALOG SYSTEM

| FAA-E-2853 | TITLE | LEVEL AND METHOD | | | REMARKS |
|------------|---|------------------|--------|-------|---------|
| | | UNIT | SYSTEM | FIELD | |
| 3.1.2.1 | DUTY CYCLE - CAPABLE OF CONTINUOUS OPERATION | A | A | X | |
| 3.1.2.2 | AMBIENT TEMPERATURE - OPERATE WITHIN SPEC OVER FOLLOWING RANGE : 0 DEG C TO +50 DEG C | D | A | X | |
| 3.1.2.3 | RELATIVE HUMIDITY - OPERATE WITHIN SPEC OVER FOLLOWING RANGE : 95% AT 40 DEG C WITHOUT CONDENSATION | D | A | X | |
| 3.1.2.4 | POWER - ALL EQUIP EXCLUDING BATTERY CHARGER OPERATE WITHIN SPEC WITH INPUT OF -24 VDC (-21 TO -28 VDC) OR -48 VDC (-42 TO -54 VDC) WITH A MAXIMUM RIPPLE OF 300mv - BATTERY CHARGER TO OPERATE AT 120 VOLTS +/-10%, 60 Hz AC +/-2%. | D | A | X | |
| 3.1.2.5 | RACKS - EQUIP INSTALLED INDOORS MOUNTED IN STD 19" OR 23" RACKS, NO MORE THAN 7' TALL - BATTERY CHARGER MOUNTED IN ACCORD- ANCE WITH 3.8 - ALL CONNECTIONS WITHIN 7' RACK - BATTERY CHARGER WALL OR RACK MOUNTED - BATTERIES MOUNTED IN STD BATTERY RACKS, EXCEPT AS AN OPTION, EARTH- QUAKE RESISTANT FREE STANDING RACKS PROVIDED AT LOCATIONS WHERE ORDERED BY GOVERNMENT - TOP ACCESS FOR EXTERNAL CABLES, BOTTOM ACCESS WHEN ORDERED BY GOVT. - ALL EQUIP PROVIDED WITH REMOVABLE DUST COVERS OR OTHER METHODS TO PREVENT DUST ON COMPONENT PARTS - ALL WIRING WITHIN NATIONAL ELECTRIC CODE | I | I | X | |

LDRCL TVRTM
1.8-GHz ANALOG SYSTEM

| FAA-E-2853 | TITLE | LEVEL AND METHOD | | | REMARKS |
|------------|---|------------------|--------|-------|---------|
| | | UNIT | SYSTEM | FIELD | |
| 3.1.2.7 | SOLID STATE - USE ONLY SOLID STATE FOR ACTIVE COMPONENTS, EXCEPT FOR RELAYS, SWITCHES AND METERS | I | I | I | |
| 3.1.2.8 | ACCESSIBILITY - EQUIP CONSTRUCTED SO THAT EACH MODULE AND SUBASSEMBLY IS EASILY ACCESSIBLE. - MODULE AND SUBASSEMBLY MOUNTED TO TO PERMIT REPLACEMENT WITHOUT REMOVAL OF OTHER MODULES OR SUBASSEMBLIES. - RACK CABLING ARRANGED SO THAT EQUIP CAN BE REMOVED AND INSERTED WITHOUT DAMAGE TO EQUIP OR CABLING. - UNUSED MUX SHELF POSITIONS WIRED NOT EQUIPPED AND CONNECTORIZED - MOST OF MAINTENANCE ACCOMPLISHED FROM FRONT | I | I | I | |
| 3.1.2.9 | TRANSIENT PROTECTION, GROUNDING, BONDING AND SHIELDING - IN ACCORDANCE WITH FAA-E-019 AND FAA-E-020. | I | I | I | |
| 3.1.2.10 | FINISHES - IN ACCORDANCE WITH CONTRACTOR COMMERCIAL STANDARDS | I | I | I | |
| 3.1.2.11 | COOLING - CONVECTION COOLING FOR MOST OF THE SYTSTEM - FORCED AIR TO EXTEND SERVICE LIFE WITH AIR FLOW MONITOR AND ALARM TO DETECT FAILURE OF AIR FLOW | I | I | I | |
| 3.1.2.12 | INTER-CHANGEABILITY - CKT CARDS, PWR SUPPLIES, MODULES AND OTHER ASSEMBLIES OF THE SAME TYPE AND MANUFACTURE INTERCHANGEABLE AND INTEROPERABLE. | D | A | X | |

LDRCL TVRTM
1.8-GHz ANALOG SYSTEM

| FAA-E-2853 | TITLE | LEVEL AND METHOD | | | REMARKS |
|------------|--|------------------|--------|-------|---------|
| | | UNIT | SYSTEM | FIELD | |
| 3.1.2.13 | SPECIAL EQUIPMENT - IDENTIFY AND SUPPLY ANY SPECIAL/ UNIQUE TEST EQUIP, TOOLS, CABLES AND EXTENDER CARDS REQUIRED FOR TEST AND ADJUSTMENT AND ONLY AVAIL- ABLE FROM CONTRACTOR. | I | I | I | |
| 3.2 | REQUIRED CHARACTERISTICS | | | | TITLE |
| 3.2.1 | GENERAL - ALL EQUIP COMMERCIALY AVAILABLE OFF-THE-SHELF. - IN ACCORDANCE WITH REQUIREMENTS - MEET ALL RQMTS WHEN ASSEMBLED INTO CONFIG FOR FIELD INSTALLATION. | I | T | X | |
| 3.2.2 | MICROWAVE RADIO EQUIPMENT | | | | TITLE |
| 3.2.2.1 | SPECTRUM DESIGN REQUIREMENTS - XMITTERS AND RCVRS IN ACCORDANCE RQMTS OF NTIA MANUAL. - DESIGNED FOR EFFICIENT USE OF SPECTRUM | D | X | I | |
| 3.2.2.2 | FREQUENCY AND ANTENNA POLARIZATION ASSIGNMENTS - PROVIDE FREQ AND ANT POLARIZATION ASSIGNMENT CRITERIA. - INCLUDE ALL NECESSARY DATA FOR SYSTEM OPERATION IN CONGESTED AREAS - INCLUDE INTERMOD, LOCAL OSC, IMAGE FREQ AND ALL OTHER CONSIDERATIONS TO ALLOW FREQ ASSIGNMENTS FOR SYS OPERATION IN ACCORDANCE WITH SPEC. - PROVIDE INFO TO ALLOW GOVT TO CHANGE FREQ WITHIN OPERATING BAND. | D | D | I | |
| 3.2.3 | EQUIPMENT CONFIGURATION - RADIO EQUIP CONFIGURED FOR HOT STANDBY OPERATION WITH FAULT SENS- ING AND NOISE SQUELCH CIRCUITRY AT ALL STATIONS. | X | T | T | |

LDRCL TVRTM
1.8 GHz ANALOG SYSTEM

| FAA-E-2853 | TITLE | LEVEL AND METHOD | | | REMARKS |
|-------------------|---|------------------|--------|-------|---------|
| | | UNIT | SYSTEM | FIELD | |
| 3.2.3 (CONT'D) | <ul style="list-style-type: none"> - SATISFY SPEC IN ANY CONFIGURATION ORDERED. - METHOD FOR SENSING FAILURES IN ACTIVE CHANNEL AND AUTOMATICALLY SWITCHING TO STANDBY CHANNEL - MONITOR STANDBY CHAN TO DETECT AND ALARM FAILURES TO PREVENT SWITCHING TO FAILED CHANNEL - PERMIT NORMAL ACTIVE CHAN OPERATION DURING MAINT ON STANDBY CHANNEL. - PILOT SENSING FOR DETECTING ANALOG FAILURES | | | | |
| 3.2.4 | RADIO FREQUENCY (RF) COUPLER <ul style="list-style-type: none"> - COUPLER WITH 30 dB FORWARD ATTN - MOUNTED NEAR TOP OF RACK | I | I | I | |
| 3.2.5 | RADIO FREQUENCY CONNECTORS <ul style="list-style-type: none"> - HIGH QUALITY, HIGH FREQUENCY, TYPE N, SMA, OR WAVEGUIDE | I | I | I | |
| 3.2.6 | ANTENNAS <ul style="list-style-type: none"> - LIGHTWEIGHT GRID FOR MOST APPLICATIONS - SOLID PARABOLIC DISHES WHERE REQUIRED - ANTENNAS, MOUNTS AND HARDWARE PER SPEC AND IN ACCORDANCE WITH STANDARDS RECOMMENDED IN EIA RS-195 | I | X | I | |
| 3.2.7 | TRANSMISSION LINE <ul style="list-style-type: none"> - UNPRESSURIZED FOAM COAX BETWEEN XMITTER/RCVR OUTPUT/INPUT PORTS AND ANTENNA UNLESS PATH DESIGN CRITERIA DICTATES OTHERWISE - PRESSURIZED SYSTEMS EQUIPPED WITH MAINTENANCE FREE AIR DRYER - LOW PRESSURE ALARM FOR AIR PRESSURE - ALARM FOR MONITORING SYSTEM - FOUR PORT MANIFOLD | I | X | I | |

LDRCL TVRTM
1.8-GHz ANALOG SYSTEM

| FAA-E-2853 | TITLE | LEVEL AND METHOD | | | REMARKS |
|------------|---|------------------|--------|-------|---------|
| | | UNIT | SYSTEM | FIELD | |
| 3.2.8 | RECEIVER COMBINER/SWITCH - NOT CAUSE INTERRUPTIONS OR TRANS- IENTS WHICH DEGRADE SIGNAL - NO LOSS OF DIGITAL DATA DUE TO AUTOMATIC COMBINER/SWITCH ACTION - NO ACTIVE ELEMENTS COMMON TO BOTH CHANNELS - PERMIT NORMAL SYSTEM OPERATION WITH EITHER PATH DISABLED DUE TO EQUIP FAILURE OR MAINTENANCE - NOT EFFECT TRANSMISSION IN OPPOSITE DIRECTION - FAULT SENSING CKT INDICATE WHICH CHANNEL IS ACTIVE | T | T | T | |
| 3.2.10 | ORDER WIRE SERVICE CHANNEL | | | | |
| 3.2.10.1 | GENERAL - WHEN ORDERED PROVIDE SINGLE LINK PARTY LINE CHANNEL AT ALL STATIONS - OPERATE INDEPENDENTLY OF MUX EQUIP | X | D | D | |
| 3.2.10.2 | AUXILIARY FUNCTIONS - EQUIPPED WITH OPERATOR HEADSET PLUGGED INTO FRONT PANEL - PROVIDED WITH INTEGRAL SIGNALING - LOUDSPEAKER PROVIDED FOR MONITORING | X | D | D | |
| 3.2.11 | JACK FIELDS - BANTAM JACKS FOR ANALOG TESTING AND PATCHING | I | I | I | |
| 3.2.12 | RF SPLITTER - STANDARD CONFIG 3:3 dB COUPLER - OPTIONAL 1:10 dB FOR 1.8 DIGITAL SYSTEM | I | I | I | |
| 3.2.13 | LINE CONDITIONING EQUIPMENT - ATTENUATION DEVICES TO PROVIDE UP TO 23 dB OF ATTENUATION, LOCATED CLOSE TO MULTIPLEX EQUIPMENT | I | T | T | |

LDRCL TVRTM
1.8-GHz ANALOG SYSTEM

| FAA-E-2853 | TITLE | LEVEL AND METHOD | | | REMARKS |
|------------|---|------------------|--------|-------|---------|
| | | UNIT | SYSTEM | FIELD | |
| 3.3 | PARAMETERS FOR 1.8 GHz SYSTEM | | | | |
| 3.3.1 | FREQUENCIES OF OPERATION FOR 1.8 GHz EQUIPMENT - RADIO EQUIP OPERATE IN 1700-1850 AND 2200-2300 MHz BANDS - OPERATE ANYWHERE WITHIN BAND IN ACCORDANCE WITH CCIR RECOMMENDATION 283-4. | T | T | X | |
| 3.3.3 | RF POWER - MIN XMIT POWER ONE HALF WATT AT XMITTER EQUIP OUTPUT PORT. - HIGH POWER XMITTER OPTION AVAILABLE - HIGH POWER OPTION INCREASE POWER TO AT LEAST ONE WATT WITH PROVISION FOR AT LEAST FIVE WATTS | T | T | T | |
| 3.3.4 | TRANSMITTER FREQUENCY STABILITY - BETTER THAN +/-0.0005% OVER SPEC REQUIREMENT RANGE FOR 1.8 ANALOG SYSTEM | T | T | T | |
| 3.3.5 | CHANNEL CAPACITY - INHERENT LOW DISTORTION AND INTRIN-IC NOISE CHARACTERISTICS FOR TRANS-MITTING UP 132 ANALOG VOICE CHANNELS | I | I | I | |
| 3.3.6 | TRANSMITTER FAULT SENSING - PROVIDE SENSING TECHNIQUE FOR FAIL-URES AND ALARM OUTPUT - MONITOR XMITTER PARAMETERS : a. XMITTER PWR BELOW PRESET LEVEL b. SIGNAL CONTINUITY THRU MODULA-TION CKTS TO OUTPUT OF LAST ACTIVE ELEMENT IN XMITTER CKTS c. AFC CONTROL WITH OFF FREQUENCY INDICATION | T | T | T | |
| 3.3.7 | RECEIVER FAULT SENSING - PROVIDE SENSING TECHNIQUE FOR FAIL-URES AND ALARM OUTPUT | T | T | T | |

LDRCL TVRTM
1.8-GHz ANALOG SYSTEM

| FAA-E-2853 | TITLE | LEVEL AND METHOD | | | REMARKS |
|-------------------|---|------------------|--------|-------|---------|
| | | UNIT | SYSTEM | FIELD | |
| 3.3.7 (CONT'D) | - MONITOR RECEIVER PARAMETERS : a. RECEIVER CARRIER LEVEL b. SIGNAL CONTINUITY THRU ALL RCVR DEMOD CKTS FROM RCVR IN- PUT TO LAST ACTIVE ELEMENT | | | | |
| 3.3.8 | RECEIVER NOISE FIGURE - MAX NOISE FIGURE OF 5.0 dB | D | T | L | |
| 3.3.9 | RECEIVER IMAGE REJECTION - PROVIDE MIN REJECTION OF 80dB AT IMAGE FREQ RELATIVE TO THE MID- BAND INSERTION LOSS | D | T | X | |
| 3.3.10 | IF AMPLIFIER - IF CENTER FREQ OF 35 OR 70 MHz | T | X | X | |
| 3.3.14.1 | EMPHASIS NETWORK - PROVIDE IN ACCORDANCE WITH CCIR RECOMMENDATION 257-3 FOR MAX CHAN FOR EACH MICROWAVE SYSTEM | X | T | T | |
| 3.3.14.2 | NOISE POWER RATIO - MAKE INTERMOD TEST MEASUREMENTS USING CCIR LOADING TECHNIQUES - EQUIP NPR \geq : 48 CHANNELS 51.0 dB 120 CHANNELS 50.0 dB 132 CHANNELS 50.0 dB | T | T | T | |
| 3.3.14.3 | BASEBAND FREQUENCY RESPONSE - FREQ RESPONSE FLAT WITHIN +/-0.25dB FROM 300Hz TO TOP OF BAND | T | T | T | |
| 3.3.14.4 | BASEBAND LEVEL STABILITY - SIGNAL AT RCVR BB OUTPUT NOT DEV- IATE MORE THAN +/-0.5 dB PER MONTH FROM NORMAL OUTPUT LEVEL | X | X | T | |
| 3.3.14.5 | BASEBAND REGULATION - MEET SPEC WITHOUT ANY BB REGULATION | T | T | T | |

LDRCL TVRTM
1.8-GHz ANALOG SYSTEM

| FAA-E-2853 | TITLE | LEVEL AND METHOD | | | REMARKS |
|------------|--|------------------|--------|-------|---------|
| | | UNIT | SYSTEM | FIELD | |
| 3.3.14.6 | BASEBAND INPUT AND OUTPUT IMPEDANCE - 75 OHM UNBALANCED INPUT AND OUTPUT | A | T | T | |
| 3.3.14.6.1 | BASEBAND BRIDGING - INTERCONNECT BETWEEN RCL AND LDRCL FOR MORE THAN 12 VF CHANNELS - SUPERGROUP TO SUPERGROUP TRANSLATOR GROUPS 1 AND 2 ON THE LDRCL TO GROUPS 3 THRU 7 ON THE RCL - PROVIDE ALL NECESSARY EQUIPMENT - FULLY REDUNDANT | T | T | T | |
| 3.3.14.7 | SENSING PILOT - UTILIZE A PER HOP SENSING PILOT OPERATING ABOVE USEABLE BB RANGE | T | T | T | |
| 3.3.14.8 | SQUELCH - EQUIPPED WITH RF SQUELCH CKT INITIATED BY BB NOISE ABOVE USEABLE BAND - SQUELCH ADJUSTABLE IN 3 dB STEPS BETWEEN 28 AND 34 dB FLAT WEIGHTED - SQUELCH SETS AT 30 dB FLAT WEIGHTED (58 dBRNCO) - NOISE SENSOR SWITCHES AT S/N 33 dB FLAT NOISE (55 dBRNCO) WITH A 4 dB HYSTERISIS | T | T | T | |
| 3.3.14.9 | BASEBAND RECEIVER COMBINER/SWITCH - NO ACTIVE ELEMENTS COMMON TO BOTH CHANNELS - SWITCHING TO OCCUR < 20 ms WITH TRANSIENT LEVEL DROP NOT TO EXCEED 2.5 dB - NON TRANSIENT LEVELS SHOULD NOT CHANGE MORE THAN 0.5 dB - NORMAL SYSTEM OPERATION WHEN EITHER PATH IS DISABLED - ANY COMB/SW ACTION NOT EFFECT TRANSMISSION IN OPPOSITE DIRECTION - FAULT SENSING CKT INDICATE ACTIVE CHANNEL | T | T | T | |

LDRCL TVRTM
1.8-GHz ANALOG SYSTEM

| FAA-E-2853 | TITLE | LEVEL AND METHOD | | | REMARKS | | | | | | | | |
|----------------|---|------------------|-----------------|---------------|---------------|---------------|-----------|----------------|---------------|---|---|---|--|
| | | UNIT | SYSTEM | FIELD | | | | | | | | | |
| 3.3.14.10 | RECEIVER SENSITIVITY - FOR A 30 dB S/N THE RECEIVER RSL WILL BE -82 dBm | T | T | T | | | | | | | | | |
| 3.3.14.11 | ANALOG MULTIPLEX EQUIPMENT - MUX EQUIP TO BE DTL TYPE - MASTER DTL SHELF HOLD MIN 12 FDM CARDS AND ASSOCIATED CONTAINERS - AUXILIARY SHELF HOLD MIN 12 FDM CARDS - TERMINAL STATIONS INCLUDE MASTER DTL SHELF WITH 12 FDM CARDS AND CAPABLE OF EASY INSTALLATION OF AUXILIARY DTL SHELF TO EXPAND TO 132 FDM CHANNELS - REPEATER STATIONS PROVIDED WITH OR WITHOUT DROP/INSERT CAPABILITY PER GOVT ORDER - RPTR STATIONS WITHOUT MAX 132 FDM CHAN DROP/INSERT CAPABILITY ARE WIRED NOT EQUIPED AND DESIGNED FOR EASY EXPANSION BY ADD- ING OPTIONAL DTL SHELVES - MUX EQUIP MEET FOLLOWING RQMTS | T | T | T | | | | | | | | | |
| 3.3.14.11.1 | LEVEL STABILITY - +/- 0.25 dB PER 30 DAY INTERVAL - LESS THAN +/- 0.5 dB PER YEAR | T | T | T | | | | | | | | | |
| 3.3.14.11.2 | CHANNEL AMPLITUDE FREQUENCY RESPONSE - REFERENCED TO 1000Hz : <table style="margin-left: 40px; border: none;"> <tr> <td style="text-align: center;"><u>RANGE</u></td> <td style="text-align: center;"><u>RESPONSE</u></td> </tr> <tr> <td>300 TO 600 Hz</td> <td>+0.1, -0.8 dB</td> </tr> <tr> <td>600 TO 3000Hz</td> <td>+/-0.3 dB</td> </tr> <tr> <td>3000 TO 4000Hz</td> <td>+0.1, -1.3 dB</td> </tr> </table> | <u>RANGE</u> | <u>RESPONSE</u> | 300 TO 600 Hz | +0.1, -0.8 dB | 600 TO 3000Hz | +/-0.3 dB | 3000 TO 4000Hz | +0.1, -1.3 dB | T | T | T | |
| <u>RANGE</u> | <u>RESPONSE</u> | | | | | | | | | | | | |
| 300 TO 600 Hz | +0.1, -0.8 dB | | | | | | | | | | | | |
| 600 TO 3000Hz | +/-0.3 dB | | | | | | | | | | | | |
| 3000 TO 4000Hz | +0.1, -1.3 dB | | | | | | | | | | | | |
| 3.3.14.11.3 | CHANNEL ENVELOPE DISTORTION - TERMINALS OPERATING BACK TO BACK ENVELOPE DELAY + 100 us, - 200 us THROUGHOUT BANDWIDTH OF 1000-2600 Hz | T | T | T | | | | | | | | | |

LDRCL TVRTM
1.8-GHz ANALOG SYSTEM

| FAA-E-2853 | TITLE | LEVEL AND METHOD | | | REMARKS |
|-------------|---|------------------|--------|-------|---------|
| | | UNIT | SYSTEM | FIELD | |
| 3.3.14.11.4 | FOUR-WIRE VOICE FREQUENCY INTERFACE - ALL FDM CARDS CONFIGURED FOR FOUR WIRE OPERATION AND ADJUSTABLE TO ALLOW FOLLOWING VF INTERFACE PARAMETERS AS MEASURED AT THE INPUT/OUTPUT TERMINALS : a. IMPEDANCE 600 OHMS BAL b. XMIT LEVEL 0 TO -16 dBm c. RCV LEVEL 0 TO +10 dBm d. RETURN LOSS 26 dB e. LONGITUDINAL BALANCE 45 dB f. SIGNALING OUT OF BAND WITH E&M SIGNALING | T | T | T | |
| 3.3.14.11.5 | BASEBAND INTERFACE - MEET THE FOLLOWING PARAMETERS : a. IMPEDANCE 75 OHMS UNBALANCED b. XMIT LEVEL -16 dBm MAX c. RCV LEVEL -34 dBm NOM | T | T | T | |
| 3.3.14.11.6 | CHANNEL NOISE LOOPED - a. 13 dBRNCO MAX PER IDLE CHANNEL b. 16 dBRNCO MAX PER LOADED CHANNEL | T | T | T | |
| 3.3.14.11.7 | PHASE JITTER - VF DROP TO VF DROP MAX OF 3 DEGREES PEAK TO PEAK BELOW 20 Hz MEASURED ON A 1000 Hz TEST TONE | T | T | T | |
| 3.3.14.11.8 | END-TO-END FREQ TRANSLATION ERROR - VF DROP TO VF DROP LESS THAN 1 Hz AS MEASURED ON A 1000 Hz TEST TONE | T | T | T | |
| 3.6 | REMOTE MONITORING/SENSING - PROVIDE REMOTE MONITORING/SENSING AT TERMINAL STATIONS THAT PROVIDE ALARM STATUS FOR ALL STATIONS - POLLING DEVICE PROVIDED FOR SYSTEMS WITHOUT ACCESS TO ACORN - DEVICE POLLS, STORES AND COLLECTS ALARMS | I | I | I | |

LDRCL TVRTM
1.8-GHz ANALOG SYSTEM

| FAA-E-2853 | TITLE | LEVEL AND METHOD | | | REMARKS |
|------------------|---|------------------|--------|-------|---------|
| | | UNIT | SYSTEM | FIELD | |
| 3.6. (CONT'D) | - ACORN COMPATIBLE | | | | |
| 3.6.1 | REPORTED ALARMS - MINIMUM ALARMS : a. XMITTER PARAMETERS b. RCVR PARAMETERS c. PRIMARY POWER FAILURE d. BATTERY CHARGER FAILURE e. LOW DC VOLTAGE ALARM f. MULITPLEX EQUIP ALARM g. LOW TRANSMISSION LINE PRESSURE h. OBSTRUCTION LIGHT FAILURE * i. BLDG INTRUSION ALARM * j. MIN OF 2 ADDITIONAL UNASSIGNED * k. ACTIVE/STANDBY MICROWAVE CHANNEL STATUS ALARM * GOVT PROVIDE INPUT FOR THIS ALARM (DRY CONTACT- GND & OPEN CKT) | T | T | T | |
| 3.6.2 | ALARM INDICATION - PROVIDE CAPABILITY OF REPORTING FAILURES BY AUDIO & VISUAL ALARMS - ALARMS FOR HIGH/LOW OPER PERF - ALARMS POINTS CONNECTED TO CONNECTORIZED TERMINAL BLOCK - CAPABILITY TO INTERFACE WITH EXTER- NAL ALARM MONITORING SYSTEM - COMPATIBLE WITH RCL ANMS - ALARMS NOT REMOTED TO RCL ARE COLLECTED AND TERMINATED AT SITE DESIGNATED BY THE GOVERNMENT - MEANS TO SILENCE AUDIBLE ALARM WITH VISUAL ALARM ACTIVE UNTIL FAULT CLEARED - AUDIBLE ALARM TO REACTIVATE FOR ADDITIONAL ALARMS - ALARM INDICATION TO INCLUDE STATION IDENTIFIER, TIME, TYPE, STATUS AND ANY OTHER INFO TO ALLOW QUICK CORR- RECTIVE ACTION | T | T | T | |

LDRCL TVRTM
1.8-GHz ANALOG SYSTEM

| FAA-E-2853 | TITLE | LEVEL AND METHOD | | | REMARKS |
|------------|---|------------------|--------|-------|---------|
| | | UNIT | SYSTEM | FIELD | |
| 3.6.2.1 | ALARM INTERFACE WITH RCL SYSTEM -TABS - PROVIDE RACK MOUNTED CONNECTIVITY POINT FOR ACORN INTERFACE - PROVIDE BLOCKS FOR ABOVE | T | T | T | |
| 3.6.3 | REMOTE CONTROLS - CAPABILITY TO ALLOW SELECTION OF MAIN/STANDBY EQUIP AND FOUR EXTERNAL FUNCTIONS FROM A REMOTE LOCATION | T | T | T | |
| 3.7.1 | RELIABILITY - MTBA NOT LESS THAN 10,000 HRS | A | A | X | |
| 3.7.2 | MAINTAINABILITY - MAXTTR NO MORE THAN 30 MIN | A | A | X | |
| 3.7.3 | AVAILABILITY - NOT LESS THAN 99.99% | A | A | X | |
| 3.8.1 | BATTERIES - BATTERY COMPLEMENT WITH STANDARD BATTERY RACKS CAPABLE OF OPERATING AT -24 VOLTS OR -48 VOLTS - MADE UP OF INCREMENTS TO SUSTAIN MAX CONFIGURATION FOR MIN OF 8 HRS - BATTERY CAPACITIES SIZED IN 4 HR INCREMENTS FROM MIN OF 8 HRS TO MAX OF 24 HRS - BATTERIES AND RACKS MEET FAA-E-2826 TYPE I, CLASS 2, STYLE A - SPECIAL APPLICATIONS, 30 MINUTE BATTERY BACKUP | I | X | I | |
| 3.8.1.1 | BATTERY PROTECTION - LOW VOLTAGE DISCONNECT AT 1.75 VOLTS PER CELL - REMOTE CONTROL OF LOW VOLTAGE DISCONNECT - LOCAL AND REMOTE OVERRIDE OF LOW VOLTAGE DISCONNECT FUNCTION | X | T | T | |

LDRCL TVRTM
1.8-CHz ANALOG SYSTEM

| FAA-E-2853 | TITLE | LEVEL AND METHOD | | | REMARKS |
|---------------------|--|------------------|--------|-------|---------|
| | | UNIT | SYSTEM | FIELD | |
| 3.8.1.1 (CONT'D) | <ul style="list-style-type: none"> - AUTOMATIC RESET OF LOW VOLTAGE DISCONNECT WHEN BATTERIES REACH FULL CHARGE - TRANSIENT PROTECTION | | | | |
| 3.8.2 | <p>BATTERY CHARGER</p> <ul style="list-style-type: none"> - BATTERY CHARGER TO PROVIDE 1:1 REDUNDACY TO SUPPORT SITE LOAD AND BATTERY RATING - CHARGERS RATED AT 25, 50, 75, 100, 150, 200, OR 250 AMPS PROVIDE POWER FOR INSTALLED SYSTEM - VOLTAGES -24 OR -48 VDC - SINGLE POINT OF FAILURE ELIMINATED - SIZED TO CHARGE BATTERIES IN 3.8.1 TO AT LEAST 90% BASED ON A 1:3 RATIO RECHARGE TIME WHILE ALSO POWERING EQUIPMENT - FULLY AUTOMATIC - AUTOMATIC CHARGING CIRCUITRY TO SWITCH FROM FLOAT TO HIGH RATE WITH RECTIFIER OPERATING IN CURRENT LIMITING FOR PREDETERMINED TIME - SETABLE TIMER OR SENSING CKT TO TIME LIMIT HIGH RATE OF CHARGE - HARMONIC CONTENT OF INPUT CURRENT CAUSED BY EQUIP NOT EXCEED 5% OF 60 Hz AND NO SINGLE HARMONIC >5% UNDER LINEAR LOAD CONDITIONS - OVERLOAD PROTECTION INCLUDED IN CHARGER - INPUT POWER FACTOR WITHIN 0.8 LAG TO UNITY WHEN OPERATED FROM 50 TO 100% RATED OUTPUT LOAD - INCLUDE A LOAD DISTRIBUTION POWER PANEL - COPPER GROUND BUSS BAR - RACK MOUNTED | T | T | L | |
| 3.8.2.1 | <p>OPTIONAL BATTERY CHARGER SYSTEM</p> <ul style="list-style-type: none"> - USED FOR A MINIMUM BACKUP PERIOD - PROVIDES POWER UNTIL MOTOR GENERATOR PROVIDE POWER | T | X | T | |

LDRCL TVRTM
1.8-GHz ANALOG SYSTEM

| FAA-E-2853 | TITLE | LEVEL AND METHOD | | | REMARKS |
|---------------------|---|------------------|--------|-------|---------|
| | | UNIT | SYSTEM | FIELD | |
| 3.8.2.1 (CONT'D) | - RECTIFIER/CHARGER RACK MOUNTED AND OPERATING AT -24 VDC OR -48 VDC | | | | |
| 3.8.3 | SPACE DIVERSITY - OPTION FOR 1.8 GHz - PROVIDE ALL EQUIP INCLUDING SEPARATE ANTENNA SYSTEM FOR STBY RCVR - SPACE DIVERSITY RECEIVER SWITCHES ON BIT ERROR RATE - SPACE DIVERSITY RECEIVER IDENTICAL TO NON SPACE DIVERSITY RECEIVER | T | T | T | |
| 3.8.4 | TOWERS - CONFORM TO EIA/TIA-222-E - WHEN LIGHTING IS REQUIRED PROVIDE A TOWER LIGHT FAILURE ALARM THAT INTERFACES WITH THE ANMS | I | X | D | |
| 3.8.4.1 | OBSTRUCTION LIGHTS - LIGHTS FOR TOWERS > 200 FEET - 20,000 CANDLE POWER FOR DAY AND TWILIGHT HOURS, 2,000 CANDLE POWER FOR NIGHT HOURS | A | A | I | |
| 3.8.5 | ANTENNA MOUNTS - DETERMINED BY PATH ANALYSIS - PROPOSED IN SITE PREPARATION PLAN | A | A | I | |
| 3.8.6 | GROUNDING SYSTEM - PROVIDE AIR TERMINALS, DOWN CONDUCTORS, FASTENERS, CLAMPS, ETC WITH EACH TOWER | X | X | T | |
| 3.9.1 | DRAWINGS, PARTS LIST AND COURSE MATERIALS - SITE INSTALLATION DRAWINGS PROVIDED IN HARDCOPY AND MAGNETIC MEDIA - ENG DWGS IN ACCORDANCE WITH MIL-T-31000 PARAGRAPH 3.6.4 - COURSE MATERIAL IN ACCORDANCE WITH FAA-STD-028A | I | X | X | |

LDRCL TVRTM
1.8-GHz ANALOG SYSTEM

| FAA-E-2853 | TITLE | LEVEL AND METHOD | | | REMARKS |
|-------------------|--|------------------|--------|-------|---------|
| | | UNIT | SYSTEM | FIELD | |
| 3.9.1 (CONT'D) | <ul style="list-style-type: none"> - PARTS LISTS IN HARD COPY USED FOR PROVISIONING FORMATTED IN ACCORD WITH FAA-G-1375 - PARTS LIST FOR LSA IN ACCORDANCE WITH MIL-STD-1388-2A | | | | |
| 3.9.2 | INSTRUCTION BOOKS <ul style="list-style-type: none"> - 2 COMPLETE SETS FOR EACH STATION - BOOK FOR EACH EQUIP IN ACCORDANCE WITH FAA-D-2494 AND CONTAIN <ul style="list-style-type: none"> a. GENERAL INFO AND RQMTS b. TECHNICAL DESCRIPTION c. OPERATION d. CORRECTIVE AND PREVENTIVE MAINT e. INSTALL, INTEG AND CHECKOUT f. PARTS LIST g. SCHEMATIC DIAGRAMS IN ACCORDANCE WITH DOD-STD-100 h. CKT DIAGRAMS WITH DESCRIPTIONS | I | X | I | |
| 3.10.2.1 | SITE SPARES <ul style="list-style-type: none"> - PROVIDE RECOMMENDED QUANTITY OF SITE LRU'S TO SATISFY AVAILABILITY REQUIREMENTS - PROVIDE ALL REQUIRED SITE SPARES | X | X | I | |
| 3.10.2.2 | DEPOT PARTS-PECULIAR <ul style="list-style-type: none"> - PROVIDE IN ACCORDANCE WITH FAA-G-1375 | X | X | I | |
| 4.2 | UNIT TESTS <ul style="list-style-type: none"> - CONDUCT FACTORY TESTS ON EACH SUB-ASSEMBLY IN SYSTEM - TESTS DEMONSTRATE NORMAL OPERATING TOLERANCES PER EQUIP DOCUMENTATION, SPEC AND CONFIGURATION CONTROL DOC. | T | X | X | |
| 4.3 | SYSTEM TESTS <ul style="list-style-type: none"> - CONDUCT SYSTEM END-TO-END TESTS ON FIRST SYSTEM OF EACH TYPE - TESTS DEMONSTRATE NORMAL OPERATION PER EQUIP DOC, SPEC, INSTRUCTION BOOKS AND CONFIGURATION CONTROL DOC | X | T | X | |

LDRCL TVRTM
1.8-GHz ANALOG SYSTEM

| FAA-E-2853 | TITLE | LEVEL AND METHOD | | | REMARKS |
|-----------------|--|------------------|--------|-------|---------|
| | | UNIT | SYSTEM | FIELD | |
| 4.3 (CONT'D) | - ALL OTHER SYSTEMS TESTED AT RACK LEVEL AT A MIN | | | | |
| 4.4 | FIELD TESTS - CONDUCT FIELD SYSTEM END-TO-END PERFORMANCE ACCEPTANCE TESTS ON INSTALLED SYSTEMS - TESTS DEMONSTRATE NORMAL OPERATION PER EQUIP DOCUMENTATION, SITE IN- STALLATION PLAN, SPEC, INSTRUCTION BOOK AND CONFIGURATION CONTROL DOC. - TESTS DEMONSTRATE THAT PROPAGATION PATH OPERATING WITHIN 3dB OF CAL- CULATED VALUE | X | X | T | |
| 5.0 | PREPARATION FOR DELIVERY - IN ACCORDANCE WITH BEST COMMERCIAL PRACTICES - ALASKA AND HAWAII SHIPPED THROUGH DEFENSE TRANSPORTATION SYSTEM | I | I | X | |
| 6.0 | PREPARATION FOR INSTALLATION - SITE PREP CONFORMS TO NATIONAL ELECTRICAL CODE, LOCAL CODES AND EIA INSTALLATION STANDARDS - NEW CONSTRUCTION CONFORMS TO FAA- STD-032 | X | X | I | |

NOTES:

T - TEST
D - DEMONSTRATION
I - INSPECTION
A - ANALYSIS
X - NOT APPLICABLE

APPENDIX D

UHF SYSTEM TVRTM

LDRCL TVRTM
UHF SYSTEM

| FAA-E-2853 | TITLE | LEVEL AND METHOD | | | REMARKS |
|------------|---|------------------|--------|-------|---------|
| | | UNIT | SYSTEM | FIELD | |
| 3.1.2.1 | DUTY CYCLE - CAPABLE OF CONTINUOUS OPERATION | A | A | X | |
| 3.1.2.2 | AMBIENT TEMPERATURE - OPERATE WITHIN SPEC OVER FOLLOWING RANGE : 0 DEG C TO +50 DEG C | D | A | X | |
| 3.1.2.3 | RELATIVE HUMIDITY - OPERATE WITHIN SPEC OVER FOLLOWING RANGE : 95% AT 40 DEG C WITHOUT CONDENSATION | D | A | X | |
| 3.1.2.4 | POWER - ALL EQUIP EXCLUDING BATTERY CHARGER OPERATE WITHIN SPEC WITH INPUT OF -24 VDC (-21 TO -28 VDC) OR -48 VDC (-42 TO -54 VDC) WITH A MAXIMUM RIPPLE OF 300mv - BATTERY CHARGER TO OPERATE AT 120 VOLTS +/-10%, 60 Hz AC +/-2%. | D | A | X | |
| 3.1.2.5 | RACKS - EQUIP INSTALLED INDOORS MOUNTED IN STD 19" OR 23" RACKS, NO MORE THAN 7' TALL - BATTERY CHARGER MOUNTED IN ACCORD- ANCE WITH 3.8 - ALL CONNECTIONS WITHIN 7' RACK - BATTERY CHARGER WALL OR RACK MOUNTED - BATTERIES MOUNTED IN STD BATTERY RACKS, EXCEPT AS AN OPTION, EARTH- QUAKE RESISTANT FREE STANDING RACKS PROVIDED AT LOCATIONS WHERE ORDERED BY GOVERNMENT - TOP ACCESS FOR EXTERNAL CABLES, BOTTOM ACCESS WHEN ORDERED BY GOVT. - ALL EQUIP PROVIDED WITH REMOVABLE DUST COVERS OR OTHER METHODS TO PREVENT DUST ON COMPONENT PARTS - ALL WIRING WITHIN NATIONAL ELECTRIC CODE | I | I | X | |

LDRCL TVRTM
UHF SYSTEM

| FAA-E-2853 | TITLE | LEVEL AND METHOD | | | REMARKS |
|------------|---|------------------|--------|-------|---------|
| | | UNIT | SYSTEM | FIELD | |
| 3.1.2.7 | SOLID STATE - USE ONLY SOLID STATE FOR ACTIVE COMPONENTS, EXCEPT FOR RELAYS, SWITCHES AND METERS | I | I | I | |
| 3.1.2.8 | ACCESSIBILITY - EQUIP CONSTRUCTED SO THAT EACH MODULE AND SUBASSEMBLY IS EASILY ACCESSIBLE. - MODULE AND SUBASSEMBLY MOUNTED TO TO PERMIT REPLACEMENT WITHOUT REMOVAL OF OTHER MODULES OR SUBASSEMBLIES. - RACK CABLING ARRANGED SO THAT EQUIP CAN BE REMOVED AND INSERTED WITHOUT DAMAGE TO EQUIP OR CABLING. - UNUSED MUX SHELF POSITIONS WIRED NOT EQUIPPED AND CONNECTORIZED - MOST OF MAINTENANCE ACCOMPLISHED FROM FRONT | I | I | I | |
| 3.1.2.9 | TRANSIENT PROTECTION, GROUNDING, BONDING AND SHIELDING - IN ACCORDANCE WITH FAA-E-019 AND FAA-E-020. | I | I | I | |
| 3.1.2.10 | FINISHES - IN ACCORDANCE WITH CONTRACTOR COMMERCIAL STANDARDS | I | I | I | |
| 3.1.2.11 | COOLING - CONVECTION COOLING FOR MOST OF THE SYTSTEM - FORCED AIR TO EXTEND SERVICE LIFE WITH AIR FLOW MONITOR AND ALARM TO DETECT FAILURE OF AIR FLOW | I | I | I | |
| 3.1.2.12 | INTER-CHANGEABILITY - CKT CARDS, PWR SUPPLIES, MODULES AND OTHER ASSEMBLIES OF THE SAME TYPE AND MANUFACTURE INTERCHANGEABLE AND INTEROPERABLE. | D | A | X | |

LDRCL TVRTM
UHF SYSTEM

| FAA-E-2853 | TITLE | LEVEL AND METHOD | | | REMARKS |
|------------|--|------------------|--------|-------|---------|
| | | UNIT | SYSTEM | FIELD | |
| 3.1.2.13 | SPECIAL EQUIPMENT - IDENTIFY AND SUPPLY ANY SPECIAL/ UNIQUE TEST EQUIP, TOOLS, CABLES AND EXTENDER CARDS REQUIRED FOR TEST AND ADJUSTMENT AND ONLY AVAIL- ABLE FROM CONTRACTOR. | I | I | I | |
| 3.2 | REQUIRED CHARACTERISTICS | | | | TITLE |
| 3.2.1 | GENERAL - ALL EQUIP COMMERCIALY AVAILABLE OFF-THE-SHELF. - IN ACCORDANCE WITH REQUIREMENTS - MEET ALL RQMTS WHEN ASSEMBLED INTO CONFIG FOR FIELD INSTALLATION. | I | T | X | |
| 3.2.2 | MICROWAVE RADIO EQUIPMENT | | | | TITLE |
| 3.2.2.1 | SPECTRUM DESIGN REQUIREMENTS - XMITTERS AND RCVRs IN ACCORDANCE RQMTS OF NTIA MANUAL. - DESIGNED FOR EFFICIENT USE OF SPECTRUM | D | X | I | |
| 3.2.2.2 | FREQUENCY AND ANTENNA POLARIZATION ASSIGNMENTS - PROVIDE FREQ AND ANT POLARIZATION ASSIGNMENT CRITERIA. - INCLUDE ALL NECESSARY DATA FOR SYSTEM OPERATION IN CONGESTED AREAS - INCLUDE INTERMOD, LOCAL OSC, IMAGE FREQ AND ALL OTHER CONSIDERATIONS TO ALLOW FREQ ASSIGNMENTS FOR SYS OPERATION IN ACCORDANCE WITH SPEC. - PROVIDE INFO TO ALLOW GOVT TO CHANGE FREQ WITHIN OPERATING BAND. | D | D | I | |
| 3.2.3 | EQUIPMENT CONFIGURATION - RADIO EQUIP CONFIGURED FOR HOT STANDBY OPERATION WITH FAULT SENS- ING AND NOISE SQUELCH CIRCUITRY AT ALL STATIONS. | X | T | T | |

LDRCL TVRTM
UHF SYSTEM

| FAA-E-2853 | TITLE | LEVEL AND METHOD | | | REMARKS |
|-------------------|---|------------------|--------|-------|---------|
| | | UNIT | SYSTEM | FIELD | |
| 3.2.3 (CONT'D) | <ul style="list-style-type: none"> - SATISFY SPEC IN ANY CONFIGURATION ORDERED. - METHOD FOR SENSING FAILURES IN ACTIVE CHANNEL AND AUTOMATICALLY SWITCHING TO STANDBY CHANNEL - MONITOR STANDBY CHAN TO DETECT AND ALARM FAILURES TO PREVENT SWITCHING TO FAILED CHANNEL - PERMIT NORMAL ACTIVE CHAN OPERATION DURING MAINT ON STANDBY CHANNEL. - PILOT SENSING FOR DETECTING ANALOG FAILURES | | | | |
| 3.2.4 | RADIO FREQUENCY (RF) COUPLER <ul style="list-style-type: none"> - COUPLER WITH 30 dB FORWARD ATTN - MOUNTED NEAR TOP OF RACK | I | I | I | |
| 3.2.5 | RADIO FREQUENCY CONNECTORS <ul style="list-style-type: none"> - HIGH QUALITY, HIGH FREQUENCY, TYPE N, SMA, OR WAVEGUIDE | I | I | I | |
| 3.2.6 | ANTENNAS <ul style="list-style-type: none"> - LIGHTWEIGHT GRID FOR MOST APPLICATIONS - SOLID PARABOLIC DISHES WHERE REQUIRED - ANTENNAS, MOUNTS AND HARDWARE PER SPEC AND IN ACCORDANCE WITH STANDARDS RECOMMENDED IN EIA RS-195 | I | X | I | |
| 3.2.7 | TRANSMISSION LINE <ul style="list-style-type: none"> - UNPRESSURIZED FOAM COAX BETWEEN XMITTER/RCVR OUTPUT/INPUT PORTS AND ANTENNA UNLESS PATH DESIGN CRITERIA DICTATES OTHERWISE - PRESSURIZED SYSTEMS EQUIPPED WITH MAINTENANCE FREE AIR DRYER - LOW PRESSURE ALARM FOR AIR PRESSURE - ALARM FOR MONITORING SYSTEM - FOUR PORT MANIFOLD | I | X | I | |

LDRCL TVRTM
UHF SYSTEM

| FAA-E-2853 | TITLE | LEVEL AND METHOD | | | REMARKS |
|------------|---|------------------|--------|-------|---------|
| | | UNIT | SYSTEM | FIELD | |
| 3.2.8 | RECEIVER COMBINER/SWITCH - NOT CAUSE INTERRUPTIONS OR TRANS- IENTS WHICH DEGRADE SIGNAL - NO LOSS OF DIGITAL DATA DUE TO AUTOMATIC COMBINER/SWITCH ACTION - NO ACTIVE ELEMENTS COMMON TO BOTH CHANNELS - PERMIT NORMAL SYSTEM OPERATION WITH EITHER PATH DISABLED DUE TO EQUIP FAILURE OR MAINTENANCE - NOT EFFECT TRANSMISSION IN OPPOSITE DIRECTION - FAULT SENSING CKT INDICATE WHICH CHANNEL IS ACTIVE | T | T | T | |
| 3.2.10 | ORDER WIRE SERVICE CHANNEL | | | | |
| 3.2.10.1 | GENERAL - WHEN ORDERED PROVIDE SINGLE LINK PARTY LINE CHANNEL AT ALL STATIONS - OPERATE INDEPENDENTLY OF MUX EQUIP | X | D | D | |
| 3.2.10.2 | AUXILIARY FUNCTIONS - EQUIPPED WITH OPERATOR HEADSET PLUGGED INTO FRONT PANEL - PROVIDED WITH INTEGRAL SIGNALING - LOUDSPEAKER PROVIDED FOR MONITORING | X | D | D | |
| 3.2.11 | JACK FIELDS - BANTAM JACKS FOR ANALOG TESTING AND PATCHING | I | I | I | |
| 3.2.12 | RF SPLITTER - STANDARD CONFIG 3:3 dB COUPLER | I | I | I | |
| 3.2.13 | LINE CONDITIONING EQUIPMENT - ATTENUATION DEVICES TO PROVIDE UP TO 23 dB OF ATTENUATION, LOCATED CLOSE TO MULTIPLEX EQUIPMENT | I | T | T | |
| 3.3.14.11 | ANALOG MULTIPLEX EQUIPMENT - MUX EQUIP TO BE DTL TYPE - MASTER DTL SHELF HOLDS 12 FDM CARDS | T | T | T | |

LDRCL TVRTM
UHF SYSTEM

| FAA-E-2853 | TITLE | LEVEL AND METHOD | | | REMARKS |
|-----------------------|---|------------------|--------|-------|---------|
| | | UNIT | SYSTEM | FIELD | |
| 3.3.14.11 (CONT'D) | - AUXILIARY SHELF HOLD MIN 12 FDM CARDS - TERMINAL STATIONS INCLUDE MASTER DTL SHELF WITH 12 FDM CARDS - REPEATER STATIONS PROVIDED WITH OR WITHOUT DROP/INSERT CAPABILITY PER GOVT ORDER - MUX EQUIP MEET FOLLOWING RQMTS | | | | |
| 3.3.14.11.1 | LEVEL STABILITY - +/- 0.25 dB PER 30 DAY INTERVAL - LESS THAN +/- 0.5 dB PER YEAR | T | T | T | |
| 3.3.14.11.2 | CHANNEL AMPLITUDE FREQUENCY RESPONSE - REFERENCED TO 1000Hz : <u>RANGE</u> <u>RESPONSE</u> 300 TO 600 Hz +0.1, -0.8 dB 600 TO 3000Hz +/-0.3 dB 3000 TO 4000Hz +0.1, -1.3 dB | T | T | T | |
| 3.3.14.11.3 | CHANNEL ENVELOPE DISTORTION - TERMINALS OPERATING BACK TO BACK ENVELOPE DELAY + 100 us, - 200 us THROUGHOUT BANDWIDTH OF 1000-2600 Hz | T | T | T | |
| 3.3.14.11.4 | FOUR-WIRE VOICE FREQUENCY INTERFACE - ALL FDM CARDS CONFIGURED FOR FOUR WIRE OPERATION AND ADJUSTABLE TO ALLOW FOLLOWING VF INTERFACE PARAMETERS AS MEASURED AT THE INPUT/OUTPUT TERMINALS : a. IMPEDANCE 600 OHMS BAL b. XMIT LEVEL 0 TO -16 dBm c. RCV LEVEL 0 TO +10 dBm d. RETURN LOSS 26 dB e. LONGITUDINAL BALANCE 45 dB f. SIGNALING OUT OF BAND WITH E&M SIGNALING | T | T | T | |
| 3.3.14.11.5 | BASEBAND INTERFACE - MEET THE FOLLOWING PARAMETERS : | T | T | T | |

LDRCL TVRTM
UHF SYSTEM

| FAA-E-2853 | TITLE | LEVEL AND METHOD | | | REMARKS |
|-------------------------|---|------------------|--------|-------|---------|
| | | UNIT | SYSTEM | FIELD | |
| 3.3.14.11.5 (CONT'D) | a. IMPEDANCE 75 OHMS UNBALANCED b. XMIT LEVEL -16 dBm MAX c. RCV LEVEL -34 dBm NOM | | | | |
| 3.3.14.11.6 | CHANNEL NOISE LOOPED - a. 13 dBRNCO MAX PER IDLE CHANNEL b. 16 dBRNCO MAX PER LOADED CHANNEL | T | T | T | |
| 3.3.14.11.7 | PHASE JITTER - VF DROP TO VF DROP MAX OF 3 DEGREES PEAK TO PEAK BELOW 20 Hz MEASURED ON A 1000 Hz TEST TONE | T | T | T | |
| 3.3.14.11.8 | END-TO-END FREQ TRANSLATION ERROR - VF DROP TO VF DROP LESS THAN 1 Hz AS MEASURED ON A 1000 Hz TEST TONE | T | T | T | |
| 3.4 | PARAMETERS FOR UHF EQUIPMENT | | | | |
| 3.4.1 | FREQUENCIES OF OPERATION FOR UHF - OPERATE IN 932-935 AND 941-944 MHz GOVT FIXED SERVICE BANDS - MEET ALL SPEC RQMTS ANYWHERE WITHIN BAND | T | T | T | |
| 3.4.2 | RF POWER - MIN XMIT POWER 5 WATTS MEASURED AT XMITTER EQUIP ANTENNA OUTPUT PORT - OPTIONAL AMP WITH AN ADDITIONAL 8 dB OF GAIN | T | T | T | |
| 3.4.3 | TRANSMITTER FREQUENCY STABILITY - BETTER THAN +/- 0.00015% | T | T | T | |
| 3.4.4 | RECEIVER SENSITIVITY - BETTER THAN 90 dB FOR 30 dB S/N | T | T | T | |
| 3.4.5 | CHANNEL CAPACITY - CAPABILITY TO REMOTE ONE ANALOG VOICE CHANNEL OF A 4 KHz BANDWIDTH - SIGNAL CAPABILITY PROVIDED USING E & M CONTACTS SUCH THAT RADIO CAN BE USED FOR REMOTING A TELEPHONE CKT | T | T | T | |

LDRCL TVRTM
UHF SYSTEM

| FAA-E-2853 | TITLE | LEVEL AND METHOD | | | REMARKS |
|------------|---|------------------|--------|-------|---------|
| | | UNIT | SYSTEM | FIELD | |
| 3.4.7 | MULTICHANNEL UHF LINK - OPTION CAPABLE OF TRANSMITTING UP TO 12 FDM VOICE CHANNELS USING MUX EQUIPMENT WHEN ORDERED BY GOVT - PROVIDE LINK IN FULL DUPLEX HOT STANDBY CONFIGURATION - PROVIDE WHEN ORDERED, POWER AMP CAPABLE OF MAX OUTPUT AUTHORIZED BY FCC DOCKET 89-45 | T | T | T | |
| 3.4.7.1 | MULTIPLEX EQUIPMENT - SUPPLY ANALOG MUX EQUIP CAPABLE OF UP TO 12 VOICE CHANNELS CONFORMING TO CCITT MULTIPLEX FORMAT - DTL USED WITH EACH CHANNEL ON SEPARATE CARD INDEPENDENT OF OTHER CHANNELS - EACH CHANNEL FIELD TUNEABLE WITHIN FIRST 600 CHANNELS OF CCITT FORMAT - EQUIP IN ACCORDANCE WITH 3.3.14.11 SUPPLY ONLY 12 CHANNELS | T | T | T | |
| 3.6 | REMOTE MONITORING/SENSING - PROVIDE REMOTE MONITORING/SENSING AT TERMINAL STATIONS THAT PROVIDE ALARM STATUS FOR ALL STATIONS - POLLING DEVICE PROVIDED FOR SYSTEMS WITHOUT ACCESS TO ACORN - DEVICE POLLS, STORES AND COLLECTS ALARMS - ACORN COMPATIBLE | I | I | I | |
| 3.6.1 | REPORTED ALARMS - MINIMUM ALARMS : a. XMITTER PARAMETERS b. RCVR PARAMETERS c. PRIMARY POWER FAILURE d. BATTERY CHARGER FAILURE e. LOW DC VOLTAGE ALARM f. MULTIPLEX EQUIP ALARM g. LOW TRANSMISSION LINE PRESSURE h. OBSTRUCTION LIGHT FAILURE * i. BLDG INTRUSION ALARM * | T | T | T | |

LDRCL TVRTM
UHF SYSTEM

| FAA-E-2853 | TITLE | LEVEL AND METHOD | | | REMARKS |
|-------------------|---|------------------|--------|-------|---------|
| | | UNIT | SYSTEM | FIELD | |
| 3.6.1 (CONT'D) | j. MIN OF 2 ADDITIONAL UNASSIGNED * k. ACTIVE/STANDBY MICROWAVE CHANNEL STATUS ALARM * GOVT PROVIDE INPUT FOR THIS ALARM (DRY CONTACT- GND & OPEN CKT) | | | | |
| 3.6.2 | ALARM INDICATION - PROVIDE CAPABILITY OF REPORTING FAILURES BY AUDIO & VISUAL ALARMS - ALARMS FOR HIGH/LOW OPER PERF - ALARMS POINTS CONNECTED TO CONNECTORIZED TERMINAL BLOCK - CAPABILITY TO INTERFACE WITH EXTER- NAL ALARM MONITORING SYSTEM - COMPATIBLE WITH RCL ANMS - ALARMS NOT REMOTED TO RCL ARE COLLECTED AND TERMINATED AT SITE DESIGNATED BY THE GOVERNMENT - MEANS TO SILENCE AUDIBLE ALARM WITH VISUAL ALARM ACTIVE UNTIL FAULT CLEARED - AUDIBLE ALARM TO REACTIVATE FOR ADDITIONAL ALARMS - ALARM INDICATION TO INCLUDE STATION IDENTIFIER, TIME, TYPE, STATUS AND ANY OTHER INFO TO ALLOW QUICK CORR- RECTIVE ACTION | T | T | T | |
| 3.6.2.1 | ALARM INTERFACE WITH RCL SYSTEM -TABS - PROVIDE RACK MOUNTED CONNECTIVITY POINT FOR ACORN INTERFACE - PROVIDE BLOCKS FOR ABOVE | T | T | T | |
| 3.6.3 | REMOTE CONTROLS - CAPABILITY TO ALLOW SELECTION OF MAIN/STANDBY EQUIP AND FOUR EXTER- NAL FUNCTIONS FROM A REMOTE LOCA- TION | T | T | T | |
| 3.7.1 | RELIABILITY - MTBA NOT LESS THAN 10,000 HRS | A | A | X | |

LDRCL TVRTM
UHF SYSTEM

| FAA-E-2853 | TITLE | LEVEL AND METHOD | | | REMARKS |
|------------|--|------------------|--------|-------|---------|
| | | UNIT | SYSTEM | FIELD | |
| 3.7.2 | MAINTAINABILITY - MAXTTR NO MORE THAN 30 MIN | A | A | X | |
| 3.7.3 | AVAILABILITY - NOT LESS THAN 99.99% | A | A | X | |
| 3.8.1 | BATTERIES - BATTERY COMPLEMENT WITH STANDARD BATTERY RACKS CAPABLE OF OPERATING AT -24 VOLTS OR -48 VOLTS - MADE UP OF INCREMENTS TO SUSTAIN MAX CONFIGURATION FOR MIN OF 8 HRS - BATTERY CAPACITIES SIZED IN 4 HR INCREMENTS FROM MIN OF 8 HRS TO MAX OF 24 HRS - BATTERIES AND RACKS MEET FAA-E-2826 TYPE I, CLASS 2, STYLE A - SPECIAL APPLICATIONS, 30 MINUTE BATTERY BACKUP | I | X | I | |
| 3.8.1.1 | BATTERY PROTECTION - LOW VOLTAGE DISCONNECT AT 1.75 VOLTS PER CELL - REMOTE CONTROL OF LOW VOLTAGE DISCONNECT - LOCAL AND REMOTE OVERRIDE OF LOW VOLTAGE DISCONNECT FUNCTION - AUTOMATIC RESET OF LOW VOLTAGE DISCONNECT WHEN BATTERIES REACH FULL CHARGE - TRANSIENT PROTECTION | X | T | T | |
| 3.8.2 | BATTERY CHARGER - BATTERY CHARGER TO PROVIDE 1:1 REDUNDACY TO SUPPORT SITE LOAD AND BATTERY RATING - CHARGERS RATED AT 25, 50, 75, 100, 150, 200, OR 250 AMPS PROVIDE POWER FOR INSTALLED SYSTEM - VOLTAGES -24 OR -48 VDC - SINGLE POINT OF FAILURE ELIMINATED | T | T | L | |

LDRCL TVRTM
UHF SYSTEM

| FAA-E-2853 | TITLE | LEVEL AND METHOD | | | REMARKS |
|-------------------|---|------------------|--------|-------|---------|
| | | UNIT | SYSTEM | FIELD | |
| 3.8.2 (CONT'D) | <ul style="list-style-type: none"> - SIZED TO CHARGE BATTERIES IN 3.8.1 TO AT LEAST 90% BASED ON A 1:3 RATIO RECHARGE TIME WHILE ALSO POWERING EQUIPMENT - FULLY AUTOMATIC - AUTOMATIC CHARGING CIRCUITRY TO SWITCH FROM FLOAT TO HIGH RATE WITH RECTIFIER OPERATING IN CURRENT LIMITING FOR PREDETERMINED TIME - SETABLE TIMER OR SENSING CKT TO TIME LIMIT HIGH RATE OF CHARGE - HARMONIC CONTENT OF INPUT CURRENT CAUSED BY EQUIP NOT EXCEED 5% OF 60 Hz AND NO SINGLE HARMONIC >5% UNDER LINEAR LOAD CONDITIONS - OVERLOAD PROTECTION INCLUDED IN CHARGER - INPUT POWER FACTOR WITHIN 0.8 LAG TO UNITY WHEN OPERATED FROM 50 TO 100% RATED OUTPUT LOAD - INCLUDE A LOAD DISTRIBUTION POWER PANEL - COPPER GROUND BUSS BAR - RACK MOUNTED | | | | |
| 3.8.2.1 | OPTIONAL BATTERY CHARGER SYSTEM <ul style="list-style-type: none"> - USED FOR A MINIMUM BACKUP PERIOD - PROVIDES POWER UNTIL MOTOR GENERATOR PROVIDE POWER - RECTIFIER/CHARGER RACK MOUNTED AND OPERATING AT -24 VDC OR -48 VDC | T | X | T | |
| 3.8.3 | SPACE DIVERSITY <ul style="list-style-type: none"> - OPTION FOR 1.8 GHz - PROVIDE ALL EQUIP INCLUDING SEPARATE ANTENNA SYSTEM FOR STBY RCVR - SPACE DIVERSITY RECEIVER SWITCHES ON BIT ERROR RATE - SPACE DIVERSITY RECEIVER IDENTICAL TO NON SPACE DIVERSITY RECEIVER | T | T | T | |
| 3.8.4 | TOWERS <ul style="list-style-type: none"> - CONFORM TO EIA/TIA-222-E | I | X | D | |

LDRCL TVRTM
UHF SYSTEM

| FAA-E-2853 | TITLE | LEVEL AND METHOD | | | REMARKS |
|-------------------|--|------------------|--------|-------|---------|
| | | UNIT | SYSTEM | FIELD | |
| 3.8.4 (CONT'D) | - WHEN LIGHTING IS REQUIRED PROVIDE A TOWER LIGHT FAILURE ALARM THAT INTERFACES WITH THE ANMS | | | | |
| 3.8.4.1 | OBSTRUCTION LIGHTS - LIGHTS FOR TOWERS > 200 FEET - 20,000 CANDLE POWER FOR DAY AND TWILIGHT HOURS, 2,000 CANDLE POWER FOR NIGHT HOURS | A | A | I | |
| 3.8.5 | ANTENNA MOUNTS - DETERMINED BY PATH ANALYSIS - PROPOSED IN SITE PREPARATION PLAN | A | A | I | |
| 3.8.6 | GROUNDING SYSTEM - PROVIDE AIR TERMINALS, DOWN CONDUCTORS, FASTENERS, CLAMPS, ETC WITH EACH TOWER | X | X | T | |
| 3.9.1 | DRAWINGS, PARTS LIST AND COURSE MATERIALS - SITE INSTALLATION DRAWINGS PROVIDED IN HARDCOPY AND MAGNETIC MEDIA - ENG DWGS IN ACCORDANCE WITH MIL-T- 31000 PARAGRAPH 3.6.4 - COURSE MATERIAL IN ACCORDANCE WITH FAA-STD-028A - PARTS LISTS IN HARD COPY USED FOR PROVISIONING FORMATTED IN ACCORD WITH FAA-G-1375 - PARTS LIST FOR LSA IN ACCORDANCE WITH MIL-STD-1388-2A | I | X | X | |
| 3.9.2 | INSTRUCTION BOOKS - 2 COMPLETE SETS FOR EACH STATION - BOOK FOR EACH EQUIP IN ACCORDANCE WITH FAA-D-2494 AND CONTAIN a. GENERAL INFO AND RQMTS b. TECHNICAL DESCRIPTION c. OPERATION d. CORRECTIVE AND PREVENTIVE MAINT e. INSTALL, INTEG AND CHECKOUT f. PARTS LIST | I | X | I | |

LDRCL TVRTM
UHF SYSTEM

| FAA-E-2853 | TITLE | LEVEL AND METHOD | | | REMARKS |
|-------------------|---|------------------|--------|-------|---------|
| | | UNIT | SYSTEM | FIELD | |
| 3.9.2 (CONT'D) | g. SCHEMATIC DIAGRAMS IN ACCORDANCE WITH DOD-STD-100 h. CKT DIAGRAMS WITH DESCRIPTIONS | | | | |
| 3.10.2.1 | SITE SPARES - PROVIDE RECOMMENDED QUANTITY OF SITE LRU'S TO SATISFY AVAILABILITY REQUIREMENTS - PROVIDE ALL REQUIRED SITE SPARES | X | X | I | |
| 3.10.2.2 | DEPOT PARTS-PECULIAR - PROVIDE IN ACCORDANCE WITH FAA-G-1375 | X | X | I | |
| 4.2 | UNIT TESTS - CONDUCT FACTORY TESTS ON EACH SUB-ASSEMBLY IN SYSTEM - TESTS DEMONSTRATE NORMAL OPERATING TOLERANCES PER EQUIP DOCUMENTATION, SPEC AND CONFIGURATION CONTROL DOC. | T | X | X | |
| 4.3 | SYSTEM TESTS - CONDUCT SYSTEM END-TO-END TESTS ON FIRST SYSTEM OF EACH TYPE - TESTS DEMONSTRATE NORMAL OPERATION PER EQUIP DOC, SPEC, INSTRUCTION BOOKS AND CONFIGURATION CONTROL DOC - ALL OTHER SYSTEMS TESTED AT RACK LEVEL AT A MIN | X | T | X | |
| 4.4 | FIELD TESTS - CONDUCT FIELD SYSTEM END-TO-END PERFORMANCE ACCEPTANCE TESTS ON INSTALLED SYSTEMS - TESTS DEMONSTRATE NORMAL OPERATION PER EQUIP DOCUMENTATION, SITE INSTALLATION PLAN, SPEC, INSTRUCTION BOOK AND CONFIGURATION CONTROL DOC. - TESTS DEMONSTRATE THAT PROPAGATION PATH OPERATING WITHIN 3dB OF CALCULATED VALUE | X | X | T | |

LDRCL TVRTM
UHF SYSTEM

| FAA-E-2853 | TITLE | LEVEL AND METHOD | | | REMARKS |
|------------|--|------------------|--------|-------|---------|
| | | UNIT | SYSTEM | FIELD | |
| 5.0 | PREPARATION FOR DELIVERY - IN ACCORDANCE WITH BEST COMMERCIAL PRACTICES - ALASKA AND HAWAII SHIPPED THROUGH DEFENSE TRANSPORTATION SYSTEM | I | I | X | |
| 6.0 | PREPARATION FOR INSTALLATION - SITE PREP CONFORMS TO NATIONAL ELECTRICAL CODE, LOCAL CODES AND EIA INSTALLATION STANDARDS - NEW CONSTRUCTION CONFORMS TO FAA-STD-032 | X | X | I | |

NOTES:

- T - TEST
- D - DEMONSTRATION
- I - INSPECTION
- A - ANALYSIS
- X - NOT APPLICABLE

APPENDIX E

23-GHz DIGITAL SYSTEM TVRTM

LDRCL TVRTM
23-GHz DIGITAL SYSTEM

| FAA-E-2853 | TITLE | LEVEL AND METHOD | | | REMARKS |
|------------|---|------------------|--------|-------|---------|
| | | UNIT | SYSTEM | FIELD | |
| 3.1.2.1 | DUTY CYCLE - CAPABLE OF CONTINUOUS OPERATION | A | A | X | |
| 3.1.2.2 | AMBIENT TEMPERATURE - OPERATE WITHIN SPEC OVER FOLLOWING RANGE : 0 DEG C TO +50 DEG C | D | A | X | |
| 3.1.2.3 | RELATIVE HUMIDITY - OPERATE WITHIN SPEC OVER FOLLOWING RANGE : 95% AT 40 DEG C WITHOUT CONDENSATION | D | A | X | |
| 3.1.2.4 | POWER - ALL EQUIP EXCLUDING BATTERY CHARGER OPERATE WITHIN SPEC WITH INPUT OF -24 VDC (-21 TO -28 VDC) OR -48 VDC (-42 TO -54 VDC) WITH A MAXIMUM RIPPLE OF 300mv - BATTERY CHARGER TO OPERATE AT 120 VOLTS +/-10%, 60 Hz AC +/-2%. | D | A | X | |
| 3.1.2.5 | RACKS - EQUIP INSTALLED INDOORS MOUNTED IN STD 19" OR 23" RACKS, NO MORE THAN 7' TALL - BATTERY CHARGER MOUNTED IN ACCORD- ANCE WITH 3.8 - ALL CONNECTIONS WITHIN 7' RACK - BATTERY CHARGER WALL OR RACK MOUNTED - BATTERIES MOUNTED IN STD BATTERY RACKS, EXCEPT AS AN OPTION, EARTH- QUAKE RESISTANT FREE STANDING RACKS PROVIDED AT LOCATIONS WHERE ORDERED BY GOVERNMENT - TOP ACCESS FOR EXTERNAL CABLES, BOTTOM ACCESS WHEN ORDERED BY GOVT. - ALL EQUIP PROVIDED WITH REMOVABLE DUST COVERS OR OTHER METHODS TO PREVENT DUST ON COMPONENT PARTS - ALL WIRING WITHIN NATIONAL ELECTRIC CODE | I | I | X | |

LDRCL TVRTM
23-GHz DIGITAL SYSTEM

| FAA-E-2853 | TITLE | LEVEL AND METHOD | | | REMARKS |
|------------|---|------------------|--------|-------|---------|
| | | UNIT | SYSTEM | FIELD | |
| 3.1.2.7 | SOLID STATE - USE ONLY SOLID STATE FOR ACTIVE COMPONENTS, EXCEPT FOR RELAYS, SWITCHES AND METERS | I | I | I | |
| 3.1.2.8 | ACCESSIBILITY - EQUIP CONSTRUCTED SO THAT EACH MODULE AND SUBASSEMBLY IS EASILY ACCESSIBLE. - MODULE AND SUBASSEMBLY MOUNTED TO TO PERMIT REPLACEMENT WITHOUT REMOVAL OF OTHER MODULES OR SUBASSEMBLIES. - RACK CABLING ARRANGED SO THAT EQUIP CAN BE REMOVED AND INSERTED WITHOUT DAMAGE TO EQUIP OR CABLING. - UNUSED MUX SHELF POSITIONS WIRED NOT EQUIPPED AND CONNECTORIZED - MOST OF MAINTENANCE ACCOMPLISHED FROM FRONT | I | I | I | |
| 3.1.2.9 | TRANSIENT PROTECTION, GROUNDING, BONDING AND SHIELDING - IN ACCORDANCE WITH FAA-E-019 AND FAA-E-020. | I | I | I | |
| 3.1.2.10 | FINISHES - IN ACCORDANCE WITH CONTRACTOR COMMERCIAL STANDARDS | I | I | I | |
| 3.1.2.11 | COOLING - CONVECTION COOLING FOR MOST OF THE SYSTEM - FORCED AIR TO EXTEND SERVICE LIFE WITH AIR FLOW MONITOR AND ALARM TO DETECT FAILURE OF AIR FLOW | I | I | I | |
| 3.1.2.12 | INTER-CHANGEABILITY - CKT CARDS, PWR SUPPLIES, MODULES AND OTHER ASSEMBLIES OF THE SAME TYPE AND MANUFACTURE INTERCHANGEABLE AND INTEROPERABLE. | D | A | X | |

LDRCL TVRTM
23-GHz DIGITAL SYSTEM

| FAA-E-2853 | TITLE | LEVEL AND METHOD | | | REMARKS |
|------------|--|------------------|--------|-------|---------|
| | | UNIT | SYSTEM | FIELD | |
| 3.1.2.13 | SPECIAL EQUIPMENT - IDENTIFY AND SUPPLY ANY SPECIAL/ UNIQUE TEST EQUIP, TOOLS, CABLES AND EXTENDER CARDS REQUIRED FOR TEST AND ADJUSTMENT AND ONLY AVAIL- ABLE FROM CONTRACTOR. | I | I | I | |
| 3.2 | REQUIRED CHARACTERISTICS | | | | TITLE |
| 3.2.1 | GENERAL - ALL EQUIP COMMERCIALY AVAILABLE OFF-THE-SHELF. - IN ACCORDANCE WITH REQUIREMENTS - MEET ALL RQMTS WHEN ASSEMBLED INTO CONFIG FOR FIELD INSTALLATION. | I | T | X | |
| 3.2.2 | MICROWAVE RADIO EQUIPMENT | | | | TITLE |
| 3.2.2.1 | SPECTRUM DESIGN REQUIREMENTS - XMITTERS AND RCVRs IN ACCORDANCE RQMTS OF NTIA MANUAL. - DESIGNED FOR EFFICIENT USE OF SPECTRUM | D | X | I | |
| 3.2.2.2 | FREQUENCY AND ANTENNA POLARIZATION ASSIGNMENTS - PROVIDE FREQ AND ANT POLARIZATION ASSIGNMENT CRITERIA. - INCLUDE ALL NECESSARY DATA FOR SYSTEM OPERATION IN CONGESTED AREAS - INCLUDE INTERMOD, LOCAL OSC, IMAGE FREQ AND ALL OTHER CONSIDERATIONS TO ALLOW FREQ ASSIGNMENTS FOR SYS OPERATION IN ACCORDANCE WITH SPEC. - PROVIDE INFO TO ALLOW GOVT TO CHANGE FREQ WITHIN OPERATING BAND. | D | D | I | |
| 3.2.3 | EQUIPMENT CONFIGURATION - RADIO EQUIP CONFIGURED FOR HOT STANDBY OPERATION WITH FAULT SENS- ING AND NOISE SQUELCH CIRCUITRY AT ALL STATIONS. | X | T | T | |

LDRCL TVRTM
23-GHz DIGITAL SYSTEM

| FAA-E-2853 | TITLE | LEVEL AND METHOD | | | REMARKS |
|-------------------|--|------------------|--------|-------|---------|
| | | UNIT | SYSTEM | FIELD | |
| 3.2.3 (CONT'D) | <ul style="list-style-type: none"> - SATISFY SPEC IN ANY CONFIGURATION ORDERED. - METHOD FOR SENSING FAILURES IN ACTIVE CHANNEL AND AUTOMATICALLY SWITCHING TO STANDBY CHANNEL - MONITOR STANDBY CHAN TO DETECT AND ALARM FAILURES TO PREVENT SWITCHING TO FAILED CHANNEL - PERMIT NORMAL ACTIVE CHAN OPERATION DURING MAINT ON STANDBY CHANNEL. - 10E-06 BER SWITCHING FOR DIGITAL SYSTEMS | | | | |
| 3.2.4 | RADIO FREQUENCY (RF) COUPLER <ul style="list-style-type: none"> - COUPLER WITH 30 dB FORWARD ATTN - MOUNTED NEAR TOP OF RACK | I | I | I | |
| 3.2.5 | RADIO FREQUENCY CONNECTORS <ul style="list-style-type: none"> - HIGH QUALITY, HIGH FREQUENCY, TYPE N, SMA, OR WAVEGUIDE | I | I | I | |
| 3.2.6 | ANTENNAS <ul style="list-style-type: none"> - LIGHTWEIGHT GRID FOR MOST APPLICATIONS - SOLID PARABOLIC DISHES WHERE REQUIRED - ANTENNAS, MOUNTS AND HARDWARE PER SPEC AND IN ACCORDANCE WITH STANDARDS RECOMMENDED IN EIA RS-195 | I | X | I | |
| 3.2.7 | TRANSMISSION LINE <ul style="list-style-type: none"> - UNPRESSURIZED FOAM COAX BETWEEN XMITTER/RCVR OUTPUT/INPUT PORTS AND ANTENNA UNLESS PATH DESIGN CRITERIA DICTATES OTHERWISE - PRESSURIZED SYSTEMS EQUIPPED WITH MAINTENANCE FREE AIR DRYER - LOW PRESSURE ALARM FOR AIR PRESSURE - ALARM FOR MONITORING SYSTEM - FOUR PORT MANIFOLD | I | X | I | |

LDRCL TVRTM
23-GHz DIGITAL SYSTEM

| FAA-E-2853 | TITLE | LEVEL AND METHOD | | | REMARKS |
|------------|--|------------------|--------|-------|---------|
| | | UNIT | SYSTEM | FIELD | |
| 3.2.8 | RECEIVER COMBINER/SWITCH - NOT CAUSE INTERRUPTIONS OR TRANSIENTS WHICH DEGRADE SIGNAL - NO LOSS OF DIGITAL DATA DUE TO AUTOMATIC COMBINER/SWITCH ACTION - NO ACTIVE ELEMENTS COMMON TO BOTH CHANNELS - PERMIT NORMAL SYSTEM OPERATION WITH EITHER PATH DISABLED DUE TO EQUIP FAILURE OR MAINTENANCE - NOT EFFECT TRANSMISSION IN OPPOSITE DIRECTION - FAULT SENSING CKT INDICATE WHICH CHANNEL IS ACTIVE | T | T | T | |
| 3.2.9 | MULTIPLEXING EQUIPMENT - CAPABLE OF MUXING UP TO 8 DS-1 CHAN - CHAN CAPACITY AS ORDERED BY GOVT COMPLETE WITH CHAN BANKS & EQUIP REQD AT BOTH TERM ENDS TO INTERFACE WITH 4-WIRE VF & E&M ANALOG CKTS OR DS-1 LEVEL DATA STREAMS - EXTENDED SUPERFRAME FORMAT FOR DS1 - ADDITIONAL CHANNEL CARDS <ul style="list-style-type: none"> a. 4W E&M/ER b. 4W E&M/PLR/ER c. 4W TO/ER | T | T | T | |
| 3.2.9.1 | REDUNDANT CONFIGURATION - FULLY REDUNDANT AT CHAN BANK LEVEL WITH HOT STANDBY REDUNDANT CHANNEL BANK COMPONENTS FOR NO INTERRUPTION IN SERVICE FOR MORE THAN ONE CHAN | X | T | T | |
| 3.2.9.2 | MONITOR AND TEST CAPABILITY - INCORPORATE BUILT-IN DIAGNOSTICS TO INCLUDE INDIVIDUAL DS-1 LOOPBACK TESTING AND BER MONITORING | T | T | T | |
| 3.2.10 | ORDER WIRE SERVICE CHANNEL | | | | |

LDRCL TVRTM
23-GHz DIGITAL SYSTEM

| FAA-E-2853 | TITLE | LEVEL AND METHOD | | | REMARKS |
|------------|---|------------------|--------|-------|---------|
| | | UNIT | SYSTEM | FIELD | |
| 3.2.10.1 | GENERAL - WHEN ORDERED PROVIDE SINGLE LINK PARTY LINE CHANNEL AT ALL STATIONS - OPERATE INDEPENDENTLY OF MUX EQUIP | X | D | D | |
| 3.2.10.2 | AUXILIARY FUNCTIONS - EQUIPPED WITH OPERATOR HEADSET PLUGGED INTO FRONT PANEL - PROVIDED WITH INTEGRAL SIGNALING - LOUDSPEAKER PROVIDED FOR MONITORING | X | D | D | |
| 3.2.11 | JACK FIELDS - BANTAM JACKS FOR ANALOG TESTING AND PATCHING - DSX-1 JACKFIELDS FOR TESTING AND PATCHING AT A DS1 LEVEL - SEPARATE DIGITAL JACKFIELD | I | I | I | |
| 3.2.12 | RF SPLITTER - STANDARD CONFIG 3:3 dB COUPLER - OPTIONAL 1:10 dB FOR 1.8 DIGITAL SYSTEM | I | I | I | |
| 3.2.13 | LINE CONDITIONING EQUIPMENT - ATTENUATION DEVICES TO PROVIDE UP TO 23 dB OF ATTENUATION, LOCATED CLOSE TO MULTIPLEX EQUIPMENT | I | T | T | |
| 3.3.13.5 | DIGITAL MULTIPLEX EQUIPMENT - PROVIDE CAPABILITY FOR UP TO EIGHT DS-1 CHANNELS - FRONT PANEL JACKS FOR TESTING AND PATCHING - IN ACCORDANCE WITH 3.2.9 | T | T | T | |
| 3.3.13.5.1 | NARROWBAND DIGITAL MULTIPLEX EQUIP - OPTIONALLY CAPABLE OF MUXING ONE DS-1 CHAN (24 VOICE CHAN EQUIV) WITH OCCUPIED BANDWIDTH NOT TO EXCEED 1.6 MHz - EXPANDABLE TO 4 DS-1'S | T | T | T | |

LDRCL TVRTM
23-GHz DIGITAL SYSTEM

| FAA-E-2853 | TITLE | LEVEL AND METHOD | | | REMARKS |
|------------|---|------------------|--------|-------|---------|
| | | UNIT | SYSTEM | FIELD | |
| 3.5.1 | FREQUENCIES OF OPERATION FOR 23 GHz - OPERATE IN THE 21.2 TO 23.6 BAND - MEET ALL SPECS WHEN TUNED IN THESE FREQUENCY RANGES | T | T | T | |
| 3.5.2 | SYSTEM GAIN/RECEIVER THRESHOLD - >91 dB (90dB FOR 8 DS1) FOR A BER 10E-6 - THRESHOLD -75.5 dBm AT 10E-3 | T | T | T | |
| 3.5.3 | TRANSMITTER FREQUENCY STABILITY - +/- 0.01% OVER SERVICE RANGE | T | T | T | |
| 3.5.4 | EQUIPMENT PACKAGING - RF EQUIPMENT CONTAINED IN WEATHER-PROOF HOUSING FOR OUTDOOR MOUNTING - MEET SPEC REQUIREMENTS IN TEMPERATURE RANGE OF -30 TO + 50 DEGREES C WITH UP TO 100% HUMIDITY - INTERFACE MODEM 19" RACK MOUNTABLE AND WITHIN 600 FEET OF RF UNIT | I | I | I | |
| 3.5.6 | PATH RELIABILITY - PATH ENGINEERED FOR MAX OF 10E-06 BER UTILIZING PUBLISHED RAIN RATES | X | X | T | |
| 3.6 | REMOTE MONITORING/SENSING - PROVIDE REMOTE MONITORING/SENSING AT TERMINAL STATIONS THAT PROVIDE ALARM STATUS FOR ALL STATIONS - POLLING DEVICE PROVIDED FOR SYSTEMS WITHOUT ACCESS TO ACORN - DEVICE POLLS, STORES AND COLLECTS ALARMS - ACORN COMPATIBLE | I | I | I | |
| 3.6.1 | REPORTED ALARMS - MINIMUM ALARMS : a. XMITTER PARAMETERS b. RCVR PARAMETERS c. PRIMARY POWER FAILURE d. BATTERY CHARGER FAILURE e. LOW DC VOLTAGE ALARM | T | T | T | |

LDRCL TVRTM
23-GHz DIGITAL SYSTEM

| FAA-E-2853 | TITLE | LEVEL AND METHOD | | | REMARKS |
|-------------------|--|------------------|--------|-------|---------|
| | | UNIT | SYSTEM | FIELD | |
| 3.6.1 (CONT'D) | f. MULTIPLEX EQUIP ALARM g. LOW TRANSMISSION LINE PRESSURE h. OBSTRUCTION LIGHT FAILURE * i. BLDG INTRUSION ALARM * j. MIN OF 2 ADDITIONAL UNASSIGNED * k. ACTIVE/STANDBY MICROWAVE CHANNEL STATUS ALARM * GOVT PROVIDE INPUT FOR THIS ALARM (DRY CONTACT- GND & OPEN CKT) | | | | |
| 3.6.2 | ALARM INDICATION - PROVIDE CAPABILITY OF REPORTING FAILURES BY AUDIO & VISUAL ALARMS - ALARMS FOR HIGH/LOW OPER PERF ALARMS POINTS CONNECTED TO CONNECTORIZED TERMINAL BLOCK - CAPABILITY TO INTERFACE WITH EXTERNAL ALARM MONITORING SYSTEM - COMPATIBLE WITH RCL ANMS - ALARMS NOT REMOTED TO RCL ARE COLLECTED AND TERMINATED AT SITE DESIGNATED BY THE GOVERNMENT - MEANS TO SILENCE AUDIBLE ALARM WITH VISUAL ALARM ACTIVE UNTIL FAULT CLEARED - AUDIBLE ALARM TO REACTIVATE FOR ADDITIONAL ALARMS - ALARM INDICATION TO INCLUDE STATION IDENTIFIER, TIME, TYPE, STATUS AND ANY OTHER INFO TO ALLOW QUICK CORRECTIVE ACTION | T | T | T | |
| 3.6.2.1 | ALARM INTERFACE WITH RCL SYSTEM -TABS - PROVIDE RACK MOUNTED CONNECTIVITY POINT FOR ACORN INTERFACE - PROVIDE BLOCKS FOR ABOVE | T | T | T | |
| 3.6.3 | REMOTE CONTROLS - CAPABILITY TO ALLOW SELECTION OF MAIN/STANDBY EQUIP AND FOUR EXTERNAL FUNCTIONS FROM A REMOTE LOCATION | T | T | T | |

LDRCL TVRTM
23-GHz DIGITAL SYSTEM

| FAA-E-2853 | TITLE | LEVEL AND METHOD | | | REMARKS |
|------------|---|------------------|--------|-------|---------|
| | | UNIT | SYSTEM | FIELD | |
| 3.7.1 | RELIABILITY - MTBA NOT LESS THAN 10,000 HRS | A | A | X | |
| 3.7.2 | MAINTAINABILITY - MAXTTR NO MORE THAN 30 MIN | A | A | X | |
| 3.7.3 | AVAILABILITY - NOT LESS THAN 99.99% | A | A | X | |
| 3.8.1 | BATTERIES - BATTERY COMPLEMENT WITH STANDARD BATTERY RACKS CAPABLE OF OPERATING AT -24 VOLTS OR -48 VOLTS - MADE UP OF INCREMENTS TO SUSTAIN MAX CONFIGURATION FOR MIN OF 8 HRS - BATTERY CAPACITIES SIZED IN 4 HR INCREMENTS FROM MIN OF 8 HRS TO MAX OF 24 HRS - BATTERIES AND RACKS MEET FAA-E-2826 TYPE I, CLASS 2, STYLE A - SPECIAL APPLICATIONS, 30 MINUTE BATTERY BACKUP | I | X | I | |
| 3.8.1.1 | BATTERY PROTECTION - LOW VOLTAGE DISCONNECT AT 1.75 VOLTS PER CELL - REMOTE CONTROL OF LOW VOLTAGE DISCONNECT - LOCAL AND REMOTE OVERRIDE OF LOW VOLTAGE DISCONNECT FUNCTION - AUTOMATIC RESET OF LOW VOLTAGE DISCONNECT WHEN BATTERIES REACH FULL CHARGE - TRANSIENT PROTECTION | X | T | T | |
| 3.8.2 | BATTERY CHARGER - BATTERY CHARGER TO PROVIDE 1:1 REDUNDANCY TO SUPPORT SITE LOAD AND BATTERY RATING - CHARGERS RATED AT 25, 50, 75, 100, 150, 200, OR 250 AMPS PROVIDE POWER FOR INSTALLED SYSTEM - VOLTAGES -24 OR -48 VDC | T | T | L | |

LDRCL TVRTM
23-GHz DIGITAL SYSTEM

| FAA-E-2853 | TITLE | LEVEL AND METHOD | | | REMARKS |
|-------------------|---|------------------|--------|-------|---------|
| | | UNIT | SYSTEM | FIELD | |
| 3.8.2 (CONT'D) | <ul style="list-style-type: none"> - SINGLE POINT OF FAILURE ELIMINATED - SIZED TO CHARGE BATTERIES IN 3.8.1 TO AT LEAST 90% BASED ON A 1:3 RATIO RECHARGE TIME WHILE ALSO POWERING EQUIPMENT - FULLY AUTOMATIC - AUTOMATIC CHARGING CIRCUITRY TO SWITCH FROM FLOAT TO HIGH RATE WITH RECTIFIER OPERATING IN CURRENT LIMITING FOR PREDETERMINED TIME - SETABLE TIMER OR SENSING CKT TO TIME LIMIT HIGH RATE OF CHARGE - HARMONIC CONTENT OF INPUT CURRENT CAUSED BY EQUIP NOT EXCEED 5% OF 60 Hz AND NO SINGLE HARMONIC >5% UNDER LINEAR LOAD CONDITIONS - OVERLOAD PROTECTION INCLUDED IN CHARGER - INPUT POWER FACTOR WITHIN 0.8 LAG TO UNITY WHEN OPERATED FROM 50 TO 100% RATED OUTPUT LOAD - INCLUDE A LOAD DISTRIBUTION POWER PANEL - COPPER GROUND BUSS BAR - RACK MOUNTED | | | | |
| 3.8.2.1 | OPTIONAL BATTERY CHARGER SYSTEM <ul style="list-style-type: none"> - USED FOR A MINIMUM BACKUP PERIOD - PROVIDES POWER UNTIL MOTOR GENERATOR PROVIDE POWER - RECTIFIER/CHARGER RACK MOUNTED AND OPERATING AT -24 VDC OR -48 VDC | T | X | T | |
| 3.8.3 | SPACE DIVERSITY <ul style="list-style-type: none"> - OPTION FOR 1.8 GHz - PROVIDE ALL EQUIP INCLUDING SEPARATE ANTENNA SYSTEM FOR STBY RCVR - SPACE DIVERSITY RECEIVER SWITCHES ON BIT ERROR RATE - SPACE DIVERSITY RECEIVER IDENTICAL TO NON SPACE DIVERSITY RECEIVER | T | T | T | |

LDRCL TVRTM
23-GHz DIGITAL SYSTEM

| FAA-E-2853 | TITLE | LEVEL AND METHOD | | | REMARKS |
|------------|--|------------------|--------|-------|---------|
| | | UNIT | SYSTEM | FIELD | |
| 3.8.4 | TOWERS - CONFORM TO EIA/TIA-222-E - WHEN LIGHTING IS REQUIRED PROVIDE A TOWER LIGHT FAILURE ALARM THAT INTERFACES WITH THE ANMS | I | X | D | TITLE |
| 3.8.4.1 | OBSTRUCTION LIGHTS - LIGHTS FOR TOWERS > 200 FEET - 20,000 CANDLE POWER FOR DAY AND TWILIGHT HOURS, 2,000 CANDLE POWER FOR NIGHT HOURS | A | A | I | |
| 3.8.5 | ANTENNA MOUNTS - DETERMINED BY PATH ANALYSIS - PROPOSED IN SITE PREPARATION PLAN | A | A | I | |
| 3.8.6 | GROUNDING SYSTEM - PROVIDE AIR TERMINALS, DOWN CONDUCTORS, FASTENERS, CLAMPS, ETC WITH EACH TOWER | X | X | T | |
| 3.9.1 | DRAWINGS, PARTS LIST AND COURSE MATERIALS - SITE INSTALLATION DRAWINGS PROVIDED IN HARDCOPY AND MAGNETIC MEDIA - ENG DWGS IN ACCORDANCE WITH MIL-T-31000 PARAGRAPH 3.6.4 - COURSE MATERIAL IN ACCORDANCE WITH FAA-STD-028A - PARTS LISTS IN HARD COPY USED FOR PROVISIONING FORMATTED IN ACCORD WITH FAA-G-1375 - PARTS LIST FOR LSA IN ACCORDANCE WITH MIL-STD-1388-2A | I | X | X | |
| 3.9.2 | INSTRUCTION BOOKS - 2 COMPLETE SETS FOR EACH STATION - BOOK FOR EACH EQUIP IN ACCORDANCE WITH FAA-D-2494 AND CONTAIN a. GENERAL INFO AND RQMTS b. TECHNICAL DESCRIPTION c. OPERATION d. CORRECTIVE AND PREVENTIVE MAINT | I | X | I | |

LDRCL TVRTM
23-GHz DIGITAL SYSTEM

| FAA-E-2853 | TITLE | LEVEL AND METHOD | | | REMARKS |
|-------------------|---|------------------|--------|-------|---------|
| | | UNIT | SYSTEM | FIELD | |
| 3.9.2 (CONT'D) | <ul style="list-style-type: none"> e. INSTALL, INTEG AND CHECKOUT f. PARTS LIST g. SCHEMATIC DIAGRAMS IN ACCORDANCE WITH DOD-STD-100 h. CKT DIAGRAMS WITH DESCRIPTIONS | | | | |
| 3.10.2.1 | SITE SPARES - PROVIDE RECOMMENDED QUANTITY OF SITE LRU'S TO SATISFY AVAILABILITY REQUIREMENTS - PROVIDE ALL REQUIRED SITE SPARES | X | X | I | |
| 3.10.2.2 | DEPOT PARTS-PECULIAR - PROVIDE IN ACCORDANCE WITH FAA-G-1375 | X | X | I | |
| 4.2 | UNIT TESTS - CONDUCT FACTORY TESTS ON EACH SUB-ASSEMBLY IN SYSTEM - TESTS DEMONSTRATE NORMAL OPERATING TOLERANCES PER EQUIP DOCUMENTATION, SPEC AND CONFIGURATION CONTROL DOC. | T | X | X | |
| 4.3 | SYSTEM TESTS - CONDUCT SYSTEM END-TO-END TESTS ON FIRST SYSTEM OF EACH TYPE - TESTS DEMONSTRATE NORMAL OPERATION PER EQUIP DOC, SPEC, INSTRUCTION BOOKS AND CONFIGURATION CONTROL DOC - ALL OTHER SYSTEMS TESTED AT RACK LEVEL AT A MIN | X | T | X | |
| 4.4 | FIELD TESTS - CONDUCT FIELD SYSTEM END-TO-END PERFORMANCE ACCEPTANCE TESTS ON INSTALLED SYSTEMS - TESTS DEMONSTRATE NORMAL OPERATION PER EQUIP DOCUMENTATION, SITE INSTALLATION PLAN, SPEC, INSTRUCTION BOOK AND CONFIGURATION CONTROL DOC. - TESTS DEMONSTRATE THAT PROPAGATION PATH OPERATING WITHIN 3dB OF CALCULATED VALUE | X | X | T | |

LDRCL TVRTM
23-GHz DIGITAL SYSTEM

| FAA-E-2853 | TITLE | LEVEL AND METHOD | | | REMARKS |
|------------|--|------------------|--------|-------|---------|
| | | UNIT | SYSTEM | FIELD | |
| 5.0 | PREPARATION FOR DELIVERY - IN ACCORDANCE WITH BEST COMMERCIAL PRACTICES - ALASKA AND HAWAII SHIPPED THROUGH DEFENSE TRANSPORTATION SYSTEM | I | I | X | |
| 6.0 | PREPARATION FOR INSTALLATION - SITE PREP CONFORMS TO NATIONAL ELECTRICAL CODE, LOCAL CODES AND EIA INSTALLATION STANDARDS - NEW CONSTRUCTION CONFORMS TO FAA-STD-032 | X | X | I | |

NOTES:

- T - TEST
- D - DEMONSTRATION
- I - INSPECTION
- A - ANALYSIS
- X - NOT APPLICABLE