

AD-A259 611



1

DTIC
ELECTE
JAN 22 1993
S C D

STRUCTURED DESIGN

TASK 301

FUNCTIONAL REQUIREMENTS IDENTIFICATION

SUBTASK 301.2.4.2

RELIABILITY CENTERED MAINTENANCE (RCM) ANALYSIS

APJ 966-217

APJ



AMERICAN POWER JET CO. RIDGEFIELD N.J.

93 1 22 004

93-01117
25950
3978

DISTRIBUTION STATEMENT A
Approved for public release
Distribution Unlimited

REPORT DOCUMENTATION PAGE

Form Approved
OMB No. 0704-0188

1a. REPORT SECURITY CLASSIFICATION UNCLASSIFIED		1b. RESTRICTIVE MARKINGS	
2a. SECURITY CLASSIFICATION AUTHORITY		3. DISTRIBUTION/AVAILABILITY OF REPORT UNLIMITED	
2b. DECLASSIFICATION/DOWNGRADING SCHEDULE		4. PERFORMING ORGANIZATION REPORT NUMBER(S)	
4. PERFORMING ORGANIZATION REPORT NUMBER(S)		5. MONITORING ORGANIZATION REPORT NUMBER(S)	
6a. NAME OF PERFORMING ORGANIZATION AMCCOM, Army	6b. OFFICE SYMBOL (if applicable) AMSMC-MAE-EA	7a. NAME OF MONITORING ORGANIZATION	
6c. ADDRESS (City, State, and ZIP Code) Rock Island Arsenal Rock Island, IL 61299-6000		7b. ADDRESS (City, State, and ZIP Code)	
8a. NAME OF FUNDING/SPONSORING ORGANIZATION	8b. OFFICE SYMBOL (if applicable)	9. PROCUREMENT INSTRUMENT IDENTIFICATION NUMBER	
8c. ADDRESS (City, State, and ZIP Code)		10. SOURCE OF FUNDING NUMBERS	
		PROGRAM ELEMENT NO.	PROJECT NO.
		TASK NO.	WORK UNIT ACCESSION NO.
11. TITLE (Include Security Classification) Repair Level Analysis Software (LSA Subtask 303.2.7), User's Manual (Version 1.0), (APJ 966-617).			
12. PERSONAL AUTHOR(S) DULCOS, RONALD		12. PERSONAL AUTHOR(S) SHEPHERD, NED	
13a. TYPE OF REPORT FINAL		13b. TIME COVERED FROM _____ TO _____	14. DATE OF REPORT (Year, Month, Day) May 1991
15. PAGE COUNT 134		16. SUPPLEMENTARY NOTATION	
17. COSATI CODES		18. SUBJECT TERMS (Continue on reverse if necessary and identify by block number)	
FIELD	GROUP	EXECUTIVE MODULE USER'S MANUAL, TASK/SUBTASK USER'S MANUALS, AUTOMATED LOGISTICS SUPPORT ANALYSIS TOOLS, ALSAT, LOGISTICS SUPPORT ANALYSIS TASKS over	
19. ABSTRACT (Continue on reverse if necessary and identify by block number)			
<p>This User's Manual is the complete users documentation package for the prototype version of the Repair Level Analysis (RLA) software. The RLA software provides a computer assisted guide to logisticians in the performance of Repair Level Analysis as defined in MIL-STD-1388-1A. It defines, organizes, tracks, models and reports on procedures that define a weapon system maintenance concept. It refers to LSA Task 303 "Evaluation of Alternatives and Trade-Off Analysis", and fulfills the requirements of LSA Subtask 303.2.7, "Repair Level Analysis" in accordance with MIL-STD-1388-1A. RLA is a decision-making process which determines the most cost-effective actions for dealing with a failed item.</p>			
20. DISTRIBUTION/AVAILABILITY OF ABSTRACT <input checked="" type="checkbox"/> UNCLASSIFIED/UNLIMITED <input type="checkbox"/> SAME AS RPT. <input type="checkbox"/> DTIC USERS		21. ABSTRACT SECURITY CLASSIFICATION UNCLASSIFIED	
22a. NAME OF RESPONSIBLE INDIVIDUAL NED SHEPHERD		22b. TELEPHONE (Include Area Code) (309) 782-2479	22c. OFFICE SYMBOL AMSMC-MAE-EA

18. AND SUBTASKS MODULES, WEAPON SYSTEM LIFE CYCLE STAGE INDEPENDENT, LIFE CYCLE PHASES, WEAPON SYSTEM/END ITEM, STAGE, DEFINES, ORGANIZES, TRACKS, MODELS AND REPORTS ON LSA PROCEDURES, COLLATING AND FORMATTING INFORMATION, ANALYSIS PROCESS, WEAPON SYSTEM SUPPORT CONCEPT, STRUCTURED METHODOLOGIES, SURVIVABILITY AND BATTLEFIELD DAMAGE REPAIR CHARACTERISTICS, EVALUATION OF ALTERNATIVES AND TRADE-OFF ANALYSIS, LOGISTIC SUPPORT ANALYSIS, LSA, OPTIMAL SOLUTIONS, SYSTEM DESCRIPTION AND ACQUISITION DATA INPUTS, DESIGN IMPACT, COST EFFECTIVENESS, AVAILABILITY OF DATA, ON-LINE HELP, SUPPORTABILITY OBJECTIVES, WEAPON SYSTEM/END ITEM ACQUISITION, SELECTION RATIONALE, ILS ELEMENT SUBELEMENT, BATTLE DAMAGE ASSESSMENT AND REPAIR.

APJ 966-217

STRUCTURED DESIGN

LSA TASK 301

FUNCTIONAL REQUIREMENTS IDENTIFICATION

SUBTASK 301.2.4.2

RELIABILITY CENTERED MAINTENANCE (RCM) ANALYSIS

under

CONTRACT DAAA21-86-D-0025

for

DTIC QUALITY INSPECTED 8

HQ US AMCCOM
INTEGRATED LOGISTIC SUPPORT OFFICE
AMSMC-LSP
ROCK ISLAND, IL

Accession For	
NTIS GRA&I	<input checked="" type="checkbox"/>
DTIC TAB	<input type="checkbox"/>
Unannounced	<input type="checkbox"/>
Justification	

Location/	
Availability Codes	
Avail and/or	
Special	
Dist	
A-1	

by

AMERICAN POWER JET COMPANY

RIDGEFIELD, NJ

FT. EUSTIS, VA

FALLS CHURCH, VA

ST. LOUIS, MO

January 1989

TABLE OF CONTENTS

<u>TITLE</u>	<u>PAGE</u>
PROCESS 301.2.4.2, RELIABILITY CENTERED MAINTENANCE (RCM) ANALYSIS.....	1
Summary.....	1
Introduction.....	2
Downstream Efforts.....	3
1. Process 301.2.4.2.1 - Assess Criticality of Each Piece/Part in Equipment System.....	6
2. Process 301.2.4.2.2 - Economic Assessment of Scheduled Vs. Unscheduled Maintenance.....	11
3. Process 301.2.4.2.3 - Impending Failure Detection Assessment.....	16
4. Process 301.2.4.2.4 - Undetectable Impending Failure Analysis.....	26
5. Process 301.2.4.2.5 - Detectable Failure Assessment.....	31

PROCESS 301.2.4.2
RELIABILITY CENTERED MAINTENANCE (RCM) ANALYSIS

SUMMARY

The Structured System Analysis, and the corresponding Data Flow Diagrams and Data Dictionary for Reliability Centered Maintenance, (RCM) was presented in APJ Report 966-208, "Structured Analysis - Reliability Centered Maintenance (RCM)" previously reviewed and submitted.

This report develops the Structured Design based on the Data Flow Diagrams developed in the Structured Analysis. After review, the material presented herein will be provided to the programming staff for preparation of the software for this LSA task implementation.

This is a working document forwarded for review. Comments are welcome and should be directed to:

AMERICAN POWER JET COMPANY
Attn: James M. Ciccotti
705 Grand Avenue
Ridgefield, New Jersey 07657-1583
(201) 945-8203

INTRODUCTION

This task is part of the process to provide a computer assisted guide to the assessment of LSA Task 301.2.4.2, "Reliability Centered Maintenance", identified in MIL-STD 1388-1A. This LSA evaluation sub-program provides a step by step procedure concerning RCM actions to assist in the performance of RCM.

The purpose of the Reliability Centered Maintenance (RCM) Analysis is to develop a scheduled maintenance program that increases the readiness of an item of equipment by identifying failures and potential failures before they degrade system/equipment effectiveness. The RCM analysis is conducted to determine what maintenance task(s) would provide increased system/equipment reliability over the life of the system/equipment, based on a logical selection as described in AMC-PAM 750-2, "Maintenance of Supplies and Equipment Guide to Reliability Centered Maintenance". This analysis is applicable to any system/equipment development program.

The RCM process uses information generated by the Failure Modes, Effects and Criticality Analysis (FMECA) to identify those items which are critical to the reliability of the equipment and in which a failure would have an effect on readiness.

Provided herein is the Structured Systems Design (SSD) of the Data Flow Diagrams developed in APJ Report 966-208, "Structured Analysis - LSA Task 301, Functional Requirements Identification: Subtask 301.2.4.2, Reliability Centered Maintenance (RCM)". This SSD provides the step-by-step procedure to be used for conducting the RCM analysis in accordance with MIL-STD 1388-1A and AMC-P 750-2.

DOWNSTREAM EFFORTS

The questions in this Structured Systems Design will be programmed for presentation to the prospective users. Provision will be made to record all responses via the hardware (computer or terminal), save to the computer storage area, formatted and available for downstream management and technical actions.

The following Structured Systems Design maps on the Structured Systems Analysis presented in APJ Report 966-208. Each "bubble" or process in this report is translated into the actions required to execute procedure.

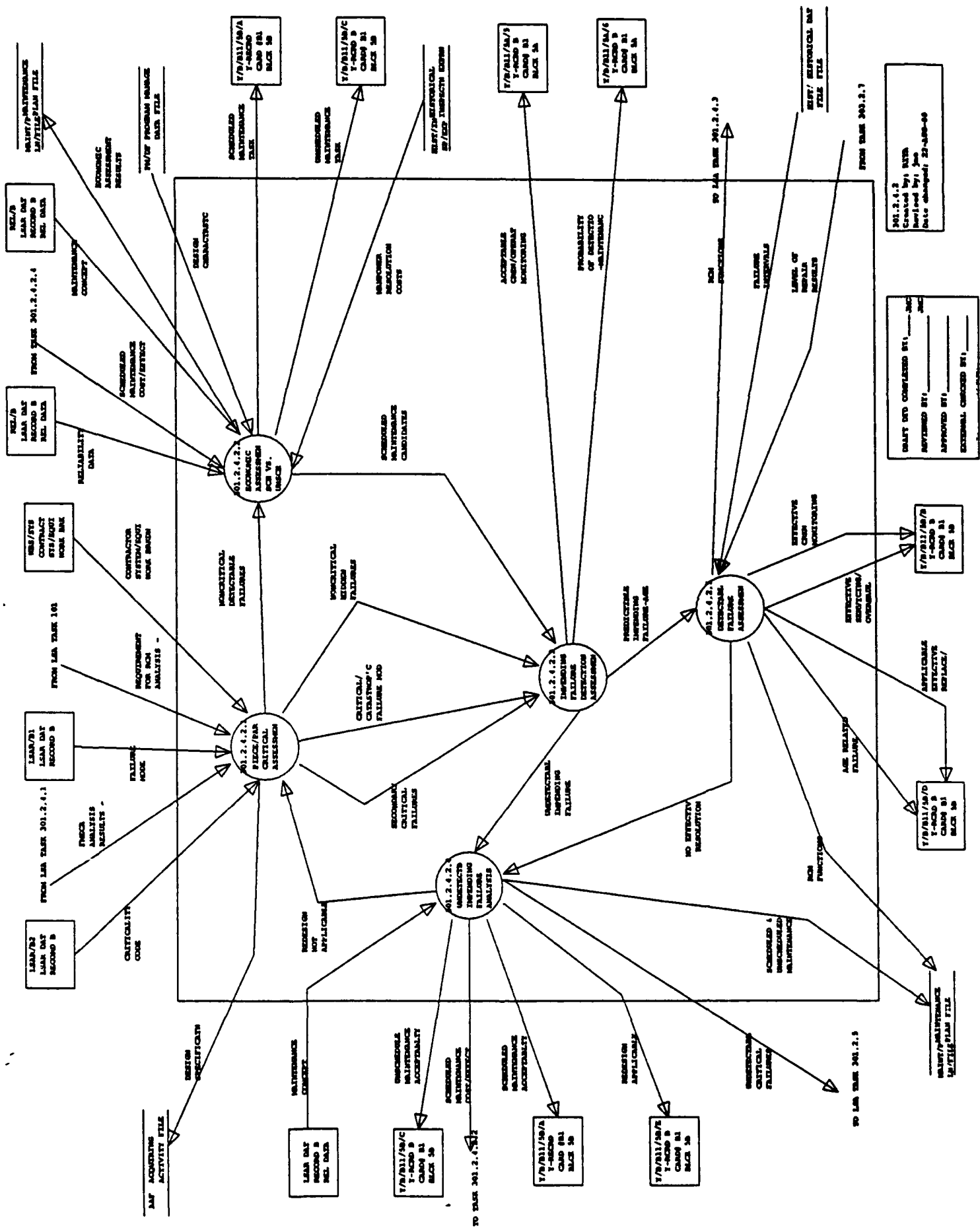

301.2.4.2
 Created by: JAC
 Revised by: JAC
 Date changed: 23-08-00

DRAFT INTO COMPLETED BY: _____
 REVIEWED BY: _____
 APPROVED BY: _____
 EXTERNAL CHECKED BY: _____

1/8/01/01/01
 T-RECORD B
 CHAD B1
 BLACK 50

1/8/01/01/01
 T-RECORD B
 CHAD B1
 BLACK 50

1/8/01/01/01
 T-RECORD B
 CHAD B1
 BLACK 50

1/8/01/01/01
 T-RECORD B
 CHAD B1
 BLACK 50

1/8/01/01/01
 T-RECORD B
 CHAD B1
 BLACK 50

1/8/01/01/01
 T-RECORD B
 CHAD B1
 BLACK 50

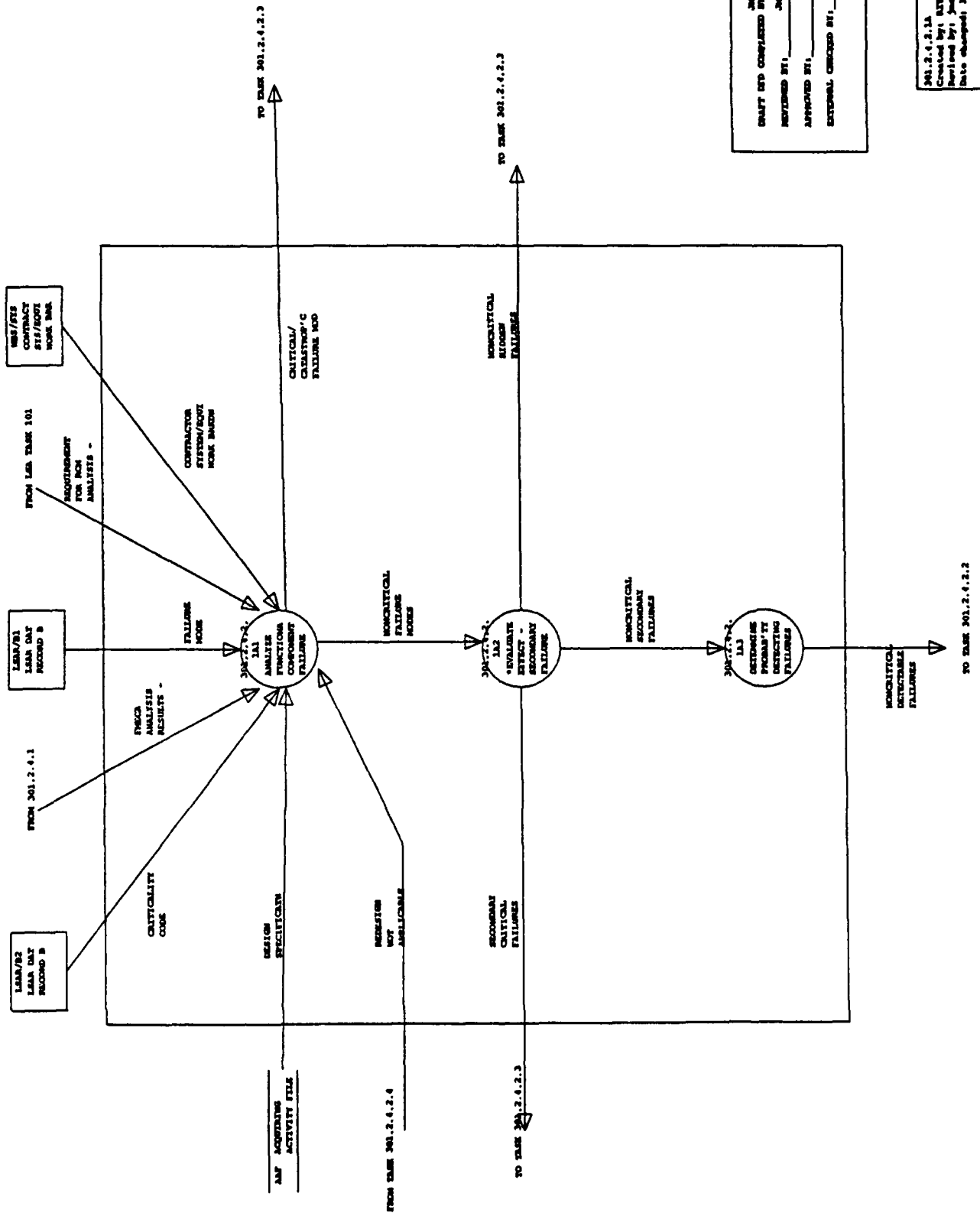

1. PROCESS 301.2.4.2.1 - ASSESS CRITICALITY OF EACH PIECE/
PART IN EQUIPMENT/SYSTEM

PROCESS 301.2.4.2.1A
ANALYZE FUNCTIONAL COMPONENT FAILURE CRITICALITY

OBJECTIVE:

THE USER SHALL INVESTIGATE THE SYSTEM/COMPONENT TO BE ANALYZED. AT THE OUTSET, THE FUNCTIONAL FAILURE IS ASSESSED FOR CONSEQUENCE OF FAILURE AND IS PROCESSED FOR ONE OF FOUR BASIC CATEGORIES:

1. CATASTROPHIC
2. CRITICAL
3. MAJOR
4. MINOR.

THE FOUR CATEGORIES ARE IDENTIFIED AS SAFETY HAZARD SEVERITY CODES (SHSC'S) 1 TO 4. WITH THE CONSEQUENT CATEGORY ESTABLISHED, THOSE TASK SELECTIONS PERTINENT TO THE CATEGORY MUST BE SELECTED. SCHEDULED MAINTENANCE TASKS SHOULD BE REVIEWED FOR NONCRITICAL (CATEGORIES 3 AND 4) COMPONENTS ONLY WHEN PERFORMANCE OF THE SCHEDULED TASK WILL REDUCE THE LIFE CYCLE COST OF THE EQUIPMENT/SYSTEM.

SCHEDULED MAINTENANCE TASKS SHOULD BE REVIEWED ON CRITICAL COMPONENTS (CATEGORIES 1 AND 2) WHEN SUCH TASKS WILL PREVENT A DECREASE IN RELIABILITY OR DETERIORATION OF SAFETY TO UNACCEPTABLE LEVELS, OR WHEN THE TASKS WILL REDUCE THE LIFE CYCLE COST OF OWNERSHIP OF THE SYSTEM/COMPONENT.

PROCEDURE:

1. OBTAIN THE APPROPRIATE FMECA WORKSHEET FROM LSA PROCESS 301.2.4.1 (FMECA ANALYSIS RESULTS) OR THE LSAR/B1

RECORD FOR THE SYSTEM/COMPONENT UNDER ANALYSIS. IF NO RECORDS ARE AVAILABLE FOR THE SYSTEM/COMPONENT UNDER ANALYSIS, FIND A DATA BASE FOR A LOGISTICALLY SIMILAR EQUIPMENT SYSTEM/COMPONENT.

2. SELECT THE ITEMS WITH A CONSEQUENCE OF FAILURE CATEGORY (SHSC'S) 1 TO 4 FROM THE FMECA WORKSHEET OR LSAR RECORD B1 AND PROCEED TO PROCESS 301.2.4.2.3 (FAILURE DETECTION ASSESSMENT).

- IF CORRESPONDING FAILURE MODE IS IDENTIFIED WITH A SHSC OR 1 OR 2.
- IF FAILURE MODE IS IDENTIFIED WITH SHSC OR 3 OR 4, BUT IS DESCRIBED AS BEING A HIDDEN FUNCTION (i.e., THE FUNCTION OF EQUIPMENT/ASSEMBLY WHOSE FAILURE IS NOT VISIBLE BY CURSORY INSPECTION WITHOUT A TEARDOWN OR REMOVAL OF SCREENING EQUIPMENT). OTHERWISE PROCEED TO PROCESS 301.2.4.2.1A2.
- IF A NONCRITICAL FAILURE MODE, SHSC 3 OR 4, CAUSES A SECONDARY FAILURE CLASSIFIED AS CRITICAL AND RESULTS IN EITHER A SAFETY HAZARD OR MISSION ABORT.

PROCESS 301.2.4.2.1A2
EVALUATE EFFECTS OF SECONDARY FAILURE

OBJECTIVE:

THE USER SHALL FURTHER INVESTIGATE THOSE NONCRITICAL FAILURE MODES FOR THE SYSTEM/COMPONENT, CLASSIFIED AS HAVING A POTENTIAL "SECONDARY FAILURE". THE IDENTIFIED NONCRITICAL FAILURE MODE WHICH COULD CAUSE A SECONDARY FAILURE IS RECLASSIFIED AS "CRITICAL" IF IT CAN RESULT IN EITHER A SAFETY HAZARD OR MISSION ABORT.

THE POTENTIAL SECONDARY FAILURE MODE WILL BE FURTHER ANALYZED TO DETERMINE WHICH SCHEDULED MAINTENANCE TASKS CAN BE PERFORMED THAT WILL PREVENT OR DECREASE THE LIKELIHOOD THAT

RELIABILITY OR SAFETY WILL DETERIORATE BELOW ACCEPTABLE LEVELS.

PROCEDURE:

1. OBTAIN THOSE PRIMARY FAILURES FROM PROCESS 301.2.4.2.1A1, INITIALLY IDENTIFIED AS BEING NONCRITICAL, BUT WHICH HAVE A POTENTIAL SECONDARY FAILURE NOW CLASSIFIED AS BEING "CRITICAL".

2. PROCEED TO PROCESS 301.2.4.2.3 (FAILURE DETECTION ASSESSMENT).

A. IF COMPONENT'S POTENTIAL FAILURE MODE OBTAINED IN STEP #1 IS CLASSIFIED AS BEING CRITICAL (SHSC 1 OR 2)

OR--

B. IF COMPONENT IS IDENTIFIED WITH SHSC OR 3 OR 4 AND IS DESCRIBED AS BEING A HIDDEN FUNCTION (i.e., THE FUNCTION OF EQUIPMENT/ASSEMBLY WHOSE FAILURE IS NOT VISIBLE CURSORY INSPECTION WITHOUT A TEARDOWN OR REMOVAL OF SCREENING EQUIPMENT).

3. IF THE POTENTIAL FAILURE MODE IS CLASSIFIED AS BEING A NONCRITICAL HIDDEN FAILURE (SHSC 3 OR 4) THAT MAY BE OPERATED TO FAILURE WITHOUT INCURRING A SAFETY HAZARD OR MISSION ABORT, THEN PROCEED TO PROCESS 301.2.4.2.1A3 FOR DETERMINING THE PROBABILITY OF DETECTING FAILURES.

PROCESS 301.2.4.2.1A3
DETERMINE THE PROBABILITY OF DETECTING FAILURES

OBJECTIVE:

THE USER SHALL INVESTIGATE AND DETERMINE THE PROBABILITY OF DETECTING A NONCRITICAL SECONDARY FAILURE THAT MAY OCCUR. A RESULTANT DECREASE IN SYSTEM/COMPONENT CAPABILITY OR ANY

SIGNAL WILL INFORM THE CREW, OPERATOR, OR MAINTENANCE PERSONNEL THAT A FAILURE HAS OCCURRED PRIOR TO ITS DETERIORATION TO A POTENTIAL CATASTROPHIC/CRITICAL FAILURE.

PROCEDURE:

1. OBTAIN THOSE POTENTIAL NONCRITICAL FAILURES FROM PROCESS 301.2.4.2.1A2 AND CATEGORIZE THEM ACCORDING TO DEGREE OF PROBABILITY OF DETECTION IDENTIFIED AS HIGH OR LOW*. THE CREW, OPERATOR, OR MAINTENANCE PERSONNEL MUST BE ABLE TO DETECT ANY CHANGES IN THE SYSTEM/COMPONENT'S OPERATIONAL CHARACTERISTICS BY THE USE OF WARNING LIGHTS, GAUGES, VIBRATION, SOUND, ETC.

2. PROCEED TO PROCESS 301.2.4.2.2 FOR DETERMINING THE ECONOMIC FEASIBILITY OF A SCHEDULED VS. UNSCHEDULED MAINTENANCE PLAN.

* REFER TO REQUIRED OPERATIONAL CHARACTERISTICS DATA IN THE ACQUIRING ACTIVITY FILE SUBMITTED AT PROCESS 301.2.4.2.1A1 FOR THE HIGH AND LOW LIMITS OF THE SYSTEM/COMPONENT UNDER ANALYSIS OR A LOGISTICALLY SIMILAR SYSTEM/COMPONENT.

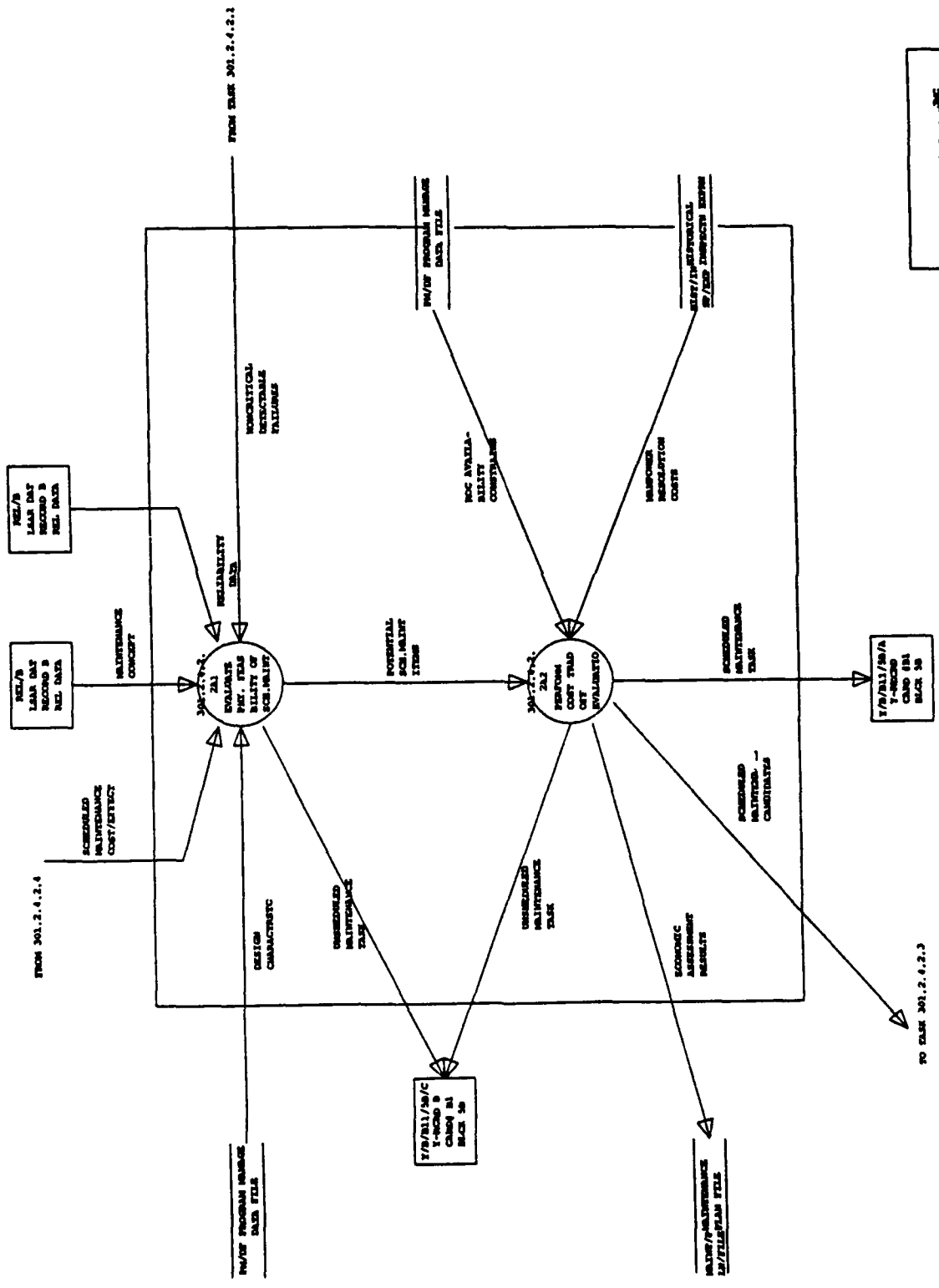

DRAFT NOT COMPLETED BY: _____
 REVIEWED BY: JMC
 APPROVED BY: _____
 EXTERNAL CHECKED BY: _____

301.2.4.2.2a
 Created by: NTA
 Revised by: JMC
 Date changed: 11-18-88-08

2. PROCESS 301.2.4.2.2 - ECONOMIC ASSESSMENT OF SCHEDULED VS. UNSCHEDULED MAINTENANCE.

PROCESS 301.2.4.2.2A1
EVALUATE PHYSICAL FEASIBILITY OF SCHEDULED MAINTENANCE

OBJECTIVE:

THE USER MUST EVALUATE EACH SYSTEM/COMPONENT AND DETERMINE ITS APPLICABILITY AND EFFECTIVENESS FOR SCHEDULED MAINTENANCE. THE APPLICABILITY AND EFFECTIVENESS MUST BE EVALUATED FOR EACH POTENTIAL FAILURE MODE AND FAILURE CONSEQUENCE.

PROCEDURE:

1. OBTAIN THOSE POTENTIAL NONCRITICAL DETECTABLE FAILURES FROM PROCESS 301.2.4.2.1 OR USE A LOGISTICALLY SIMILAR FAILURE LOCATED IN THE HISTORICAL INSPECTION FILE OR IN THE LSAR RECORD B.

2. IF THE FAILURE MAY BE PHYSICALLY DETECTABLE BY VISUAL INSPECTION AND/OR BY MEASURABLE CHANGES IN PHYSICAL PROPERTIES, AND IF IT IS POSSIBLE TO DEFINE A POTENTIAL FAILURE CONDITION BY AN EXPLICIT TASK, PROCEED TO PROCESS 301.2.4.2.2A2 TO REVIEW POTENTIAL SCHEDULED MAINTENANCE TASK(S).

3. RECORD THOSE POTENTIAL FAILURES THAT DO NOT MEET THE CRITERIA FOR ABOVE ITEM #2 INTO THE LSAR RECORD B, CARD B1, BLOCK 5B AS A CANDIDATE FOR AN UNSCHEDULED MAINTENANCE TASK.

PROCESS 301.2.4.2.2A2
PERFORM COST TRADE-OFF EVALUATION

OBJECTIVE:

THE USER WILL ANALYZE AND DETERMINE IF THOSE POTENTIAL SCHEDULED MAINTENANCE ITEMS WILL DECREASE THE LIFE CYCLE COST OF THE END ITEM. ECONOMIC CONSIDERATIONS ARE DIVIDED INTO TWO GROUPS - OPERATIONAL AND NONOPERATIONAL EFFECTS:

A. OPERATIONAL EFFECTS - TASK IS DESIRABLE IF THE COST OF THE TASK IS LESS THAN THE COMBINED COST OF THE OPERATIONAL CONSEQUENCES AND THE COST OF REPAIR.

B. NONOPERATIONAL EFFECTS - TASK IS DESIRABLE IF THE COST OF THE TASK IS LESS THAN THE COST OF REPAIR.

PROCEDURE:

1. ACQUIRE FAILURE RATE FOR A SIMILAR SYSTEM/COMPONENT FROM THE HISTORICAL DATA FILE AND DETERMINE IF FAILURE RATE IS HIGH RELATIVE TO CONTRACT OR SPECIFICATION.

A. IF FAILURE RATE IS HIGH, CONTINUE WITH ACTION (2A) BELOW; IF NOT, PROCEED TO ACTION (2b).

2. DETERMINE IF THE POTENTIAL FAILURE INVOLVES OPERATIONAL CONSEQUENCES FROM THE IDENTIFIED SAFETY HAZARD SEVERITY CODE (3 OR 4) AND PROCEED AS FOLLOWS:

A. IF FAILURE MODE IS IDENTIFIED WITH A SHSC-3, REVIEW ECONOMIC ASSESSMENT RESULTS FOUND IN THE MAINTENANCE PLAN FILE FOR A SIMILAR SYSTEM/COMPONENT.

IF DATA SHOWS A SIMILAR TASK PROVED COST-EFFECTIVE, TASK UNDER EVALUATION IS ASSUMED TO BE COST-EFFECTIVE.

- B. IF FAILURE MODE IS IDENTIFIED WITH A SHSC-4, CALCULATE TASK COST-BENEFIT RATIO (Cbr) OF PREVENTIVE MAINTENANCE TO CORRECTIVE (REPAIR) MAINTENANCE AS FOLLOWS:*

$$Cpm = (NT/Yr.) (DMMH/Preventive Task) (Labor Cost/hr)$$

Where:

Cpm = Cost of Preventive Task/Yr.

NT = No. of Proposed Preventive Tasks

DMMH = The total no. of accumulated direct labor hours expended in performing a maintenance action.

$$Ccm = (NF) (DMMH/Corrective Task) (Labor Cost/Hr)$$

Where:

Ccm = Cost of Prevented Failures

NF = No. of Failures Prevented by Proposed Task/Yr.

Cost benefit ratio:

$$Cbr = Cpm/Ccm$$

If $Cbr < 1$, the Preventive Task is considered cost-effective.

* Other costs, supply support and support equipment, are assumed to be the same for Preventive and Corrective tasks.

3. IF MAINTENANCE TASK IS PROVEN TO BE COST-EFFECTIVE, DOCUMENT THE SCHEDULED MAINTENANCE TASK IN THE LSAR RECORD B, CARD B1, BLOCK 5B AND PROCEED TO PROCESS 301.2.4.2.3.

4. IF THE COST OF SUPPLY SUPPORT AND SUPPLY EQUIPMENT IS NOT THE SAME FOR CORRECTIVE AND PREVENTIVE MAINTENANCE AS CALCULATED IN ITEM #2 ABOVE THE RELATIONSHIP CAN BE EXPRESSED AS FOLLOWS:

$$Csr = Csepm + Cssp/Csecm + Cssc$$

Where:

Csr = Cost Support Ratio.

Csepm = Cost Support Equipment for Preventive Maintenance.

Cssp = Cost Supply Support for Preventive Maintenance.

Csecm = Cost Support Equipment for Corrective Maintenance.

Cssc = Cost Supply Support for Corrective Maintenance.

A COST-BENEFIT RATIO CAN THEN BE DEVELOPED AS FOLLOWS:

$$Cbr = Cpm/Ccm \cdot Csr$$

WHEN THE Cbr IS CALCULATED TO BE LESS THAN 1, THEN THE PREVENTIVE TASK IS CONSIDERED COST EFFECTIVE.

5. DOCUMENT ECONOMIC ASSESSMENT RESULTS IN A MAINTENANCE PLAN FILE.

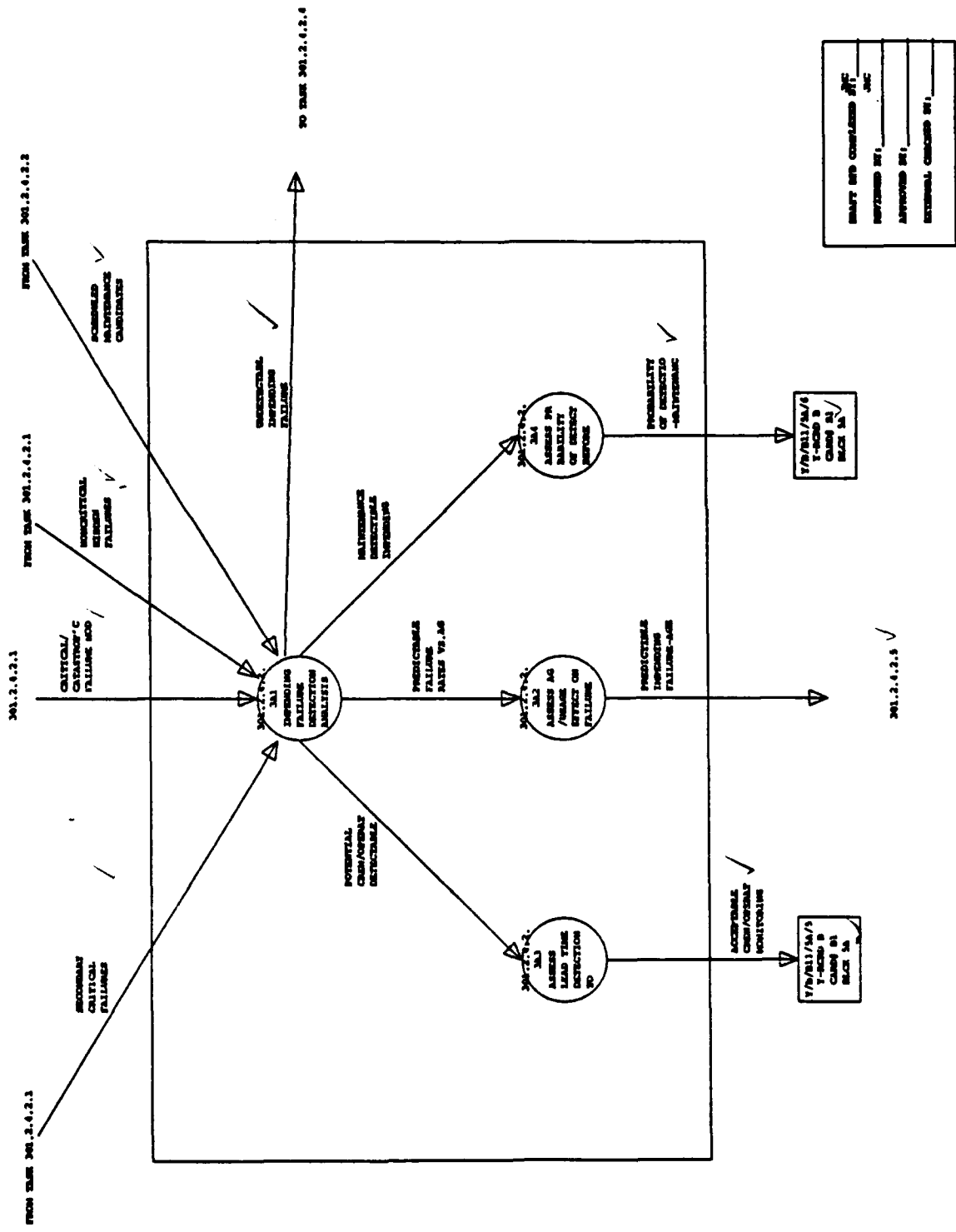

DEPT: MFC COMPLEX	DATE:
REVIEWED BY:	DATE:
APPROVED BY:	DATE:
EXTERNAL CHECKED BY:	DATE:

301.2.4.2.2
 Created by: RHM
 Verified by: Jue
 Date changed: 19-SEP-88

6. RECORD FEASIBLE SCHEDULED MAINTENANCE TASK IN THE LSAR RECORD B, CARD B1, BLOCK 5B.

7. PROCEED TO PROCESS 301.2.4.2.3 FOR FAILURE DETECTION ASSESSMENT.

8. RECORD IN THE LSAR, RECORD B, CARD B1, BLOCK 5B, THOSE POTENTIAL CANDIDATES THAT ARE FOUND TO BE ECONOMICALLY FEASIBLE FOR AN UNSCHEDULED MAINTENANCE TASK RATHER THAN A SCHEDULED MAINTENANCE TASK.

3. PROCESS 301.2.4.2.3 - IMPENDING FAILURE DETECTION ASSESSMENT.

PROCESS 301.2.4.2.3A1
IMPENDING FAILURE DETECTION ANALYSIS

OBJECTIVE:

1. THE USER WILL ANALYZE THE POTENTIAL IMPENDING FAILURE UNDER ANALYSIS AND SELECT AN APPROPRIATE MEANS OF DETECTION TO BE FURTHER ANALYZED.

THERE ARE THREE (3) MAJOR AREAS OF DETECTION THAT MUST BE CONSIDERED PRIOR TO ASSIGNING A MAINTENANCE TASK(S):

A. THE CREW/OPERATOR MUST BE ABLE TO IDENTIFY AND DETECT THOSE POTENTIAL CRITICAL FAILURE MODES THROUGH ROUTINE MONITORING WITH SUFFICIENT LEAD TIME TO PREVENT A MISSION ABORT OR SAFETY HAZARD. THE DETECTION MEANS CAN BE IN THE FORM OF INSTRUMENTS (GAUGES, WARNING LIGHTS, ETC.) OR OPERATIONAL CHARACTERISTICS (VIBRATION, SOUND, ETC.).

B. EVALUATED DATA MUST INDICATE IF THE PROBABILITY OF SYSTEM/COMPONENT FAILURE INCREASES AS CALENDAR TIME OR USAGE INDICATORS (OPERATING HOURS, MILES, ROUNDS, CYCLES) INCREASES. A SCHEDULED MAINTENANCE TASK MAY BE CONSIDERED AT A POINT IN TIME OR AFTER A SPECIFIED AMOUNT OF USAGE WHEN THE PROBABILITY OF FAILURE INCREASES TO AN UNACCEPTABLE LEVEL.

C. STATISTICAL DATA MUST INDICATE A HIGH PROBABILITY* THAT THE TIME BETWEEN ONSET OF DEGRADATION AND THE OCCURRENCE OF FAILURE IS SUCH THAT THE IMPENDING FAILURE WILL BE DETECTED AND CORRECTED BEFORE IT ACTUALLY OCCURS. THIS PROBABILITY OF DETECTION SHOULD COINCIDE WITH A SCHEDULED MAINTENANCE TASK.

PROCEDURE:

1. USE DATA FOR CRITICAL, NONCRITICAL, AND SECONDARY FAILURES FROM PROCESS 301.2.4.2.1 AND THOSE SCHEDULED MAINTENANCE CANDIDATES FROM PROCESS 301.2.4.2.2 AND ANALYZE AS FOLLOWS:

A. IF DATA (INCLUDING LEADTIME TO FAILURE INFORMATION), CONTAINED IN THE RELIABILITY REPORT FOR THE

* REFER TO REQUIRED OPERATIONAL CHARACTERISTICS DATA IN THE ACQUIRING ACTIVITY FILE SUBMITTED AT PROCESS 301.2.4.2.1a1 FOR THE HIGH AND LOW LIMITS OF THE SYSTEM/COMPONENT UNDER ANALYSIS OR A LOGISTICALLY SIMILAR SYSTEM/COMPONENT.

SYSTEM/COMPONENT*, INDICATES THAT THE IMPENDING FAILURE MAY BE DETECTED THROUGH ROUTINE CREW/OPERATOR MONITORING THEN, PROCEED TO PROCESS 301.2.4.2.3A3 FOR FURTHER ANALYSIS.

B. IF FAILURE RATES CONTAINED IN THE DETAILED DESIGN AND/OR RELIABILITY REPORT FOR THE SYSTEM/COMPONENT*, INDICATE THAT THE PROBABLE FAILURE INCREASES TO A STATISTICALLY PROVEN AGE OR USAGE LIMIT, THEN PROCEED TO PROCESS 301.2.4.2.3A2 FOR FURTHER ANALYSIS.

C. IF PROBABILITY DATA, CONTAINED IN THE DESIGN AND/OR RELIABILITY REPORT, INDICATES THAT IMPENDING FAILURE HAS A HIGH** PROBABILITY OF LEADTIME DETECTION PRIOR TO ACTUAL OCCURRENCE OF FAILURE THEN PROCEED TO TASK 301.2.4.2.3A4.

2. PROCEED TO PROCESS 301.2.4.2.4 IF THERE ARE NO MEANS OF DETECTING AN IMPENDING FAILURE FOR THE SYSTEM/COMPONENT UNDER ANALYSIS.

PROCESS 301.2.4.2.3A2
ASSESS AGE/USAGE EFFECT ON FAILURE DETECTION

OBJECTIVE:

THE USER MUST INVESTIGATE THE SYSTEM/COMPONENT UNDER ANALYSIS AND IDENTIFY THE POINT IN TIME OR A SPECIFIED AMOUNT OF USAGE WHEN THE PROBABILITY OF FAILURE INCREASES TO AN UNACCEPTABLE LEVEL.

* IF NO DATA ARE AVAILABLE FOR THE SYSTEM/COMPONENT UNDER ANALYSIS, USE DATA FOR A LOGISTICALLY SIMILAR SYSTEM/COMPONENT AS REFERENCE.

** SPECIFICATIONS FOR DEFINING "HIGH PROBABILITY" SHOULD BE OBTAINED FROM PROGRAM MANAGER'S DATA FILE FOR THE SYSTEM/COMPONENT OR LOGISTICALLY SIMILAR SYSTEM/COMPONENT UNDER ANALYSIS.

FOR THESE WEAROUT COMPONENTS, A SCHEDULED MAINTENANCE TASK (REMOVE AND REPLACE) MAY BE ASSIGNED IN ORDER TO RETURN THE PROBABILITY OF FAILURE TO ITS ORIGINAL LEVEL.

PROCEDURE:

1. USE THOSE PREDICTABLE FAILURE RATES VS. AGE RELATED DATA FOR THE SYSTEM/COMPONENT OR A LOGISTICALLY SIMILAR SYSTEM/COMPONENT FROM PROCESS 301.2.4.2.3A1.

2. IF DATA HAS AN AGE LIMIT BASED ON SOME MAXIMUM OPERATING AGE OR NUMBER OF STRESS CYCLES, THIS DATA MAY BE USED FOR IMPROVING THE OVERALL RELIABILITY OF THE SYSTEM/COMPONENT BY INITIATING A SCHEDULED REPLACEMENT/OVERHAUL MAINTENANCE TASK.

3. PROCEED TO PROCESS 301.2.4.2.5 TO DETERMINE THE APPROPRIATE MAINTENANCE TASK FOR THE SYSTEM/COMPONENT UNDER ANALYSIS.

PROCESS 301.2.4.2.3A3
ASSESS LEAD TIME DETECTION TO FAILURE

OBJECTIVE:

THE USER SHALL INVESTIGATE AND IDENTIFY THOSE CRITICAL FAILURE MODES THAT CAN BE DETECTED THROUGH ROUTINE MONITORING BY CREW/OPERATOR WITH SUFFICIENT LEADTIME TO PREVENT A SAFETY HAZARD OR MISSION ABORT. THE MEANS OF DETECTION CAN BE IN THE FORM OF INSTRUMENTS (GAUGES, WARNING LIGHTS, ETC.) OR OPERATIONAL CHARACTERISTICS (VIBRATION, SOUND, ETC.).

PROCEDURE:

1. USING DATA FROM PROCESS 301.2.4.2.3A1, RECORD THOSE POTENTIAL FAILURES IN THE LSAR RECORD B, CARD B1, BLOCK 5A FOR WHICH THERE IS SUFFICIENT TIME BETWEEN MEASURABLE FAILURE ONSET AND ACTUAL FAILURE OCCURRENCE MEASURED IN DAYS OR MONTHS. THESE POTENTIAL FAILURES ARE ACCEPTABLE CANDIDATES FOR DETECTION BY CREW/OPERATOR.

PROCESS 301.2.4.2.3A4

ASSESS PROBABILITY OF DETECTION BEFORE
FAILURE OCCURS

OBJECTIVE:

THE USER MUST REVIEW HIGH PROBABILITY DATA AND JUSTIFY THE TIME BETWEEN ONSET OF DEGRADATION AND THE OCCURRENCE OF FAILURE SUCH THAT THE IMPENDING FAILURE WILL BE DETECTED AND CORRECTED BEFORE IT ACTUALLY OCCURS. AS A RESULT, IT MAY BE POSSIBLE TO DEVELOP A SCHEDULED MAINTENANCE TASK TO COINCIDE WITH DETECTION OF DEGRADATION OF SYSTEM/COMPONENT.

PROCEDURE:

1. USE CRITICAL FAILURE MODES FROM PROCESS 301.2.4.2.3A1 THAT MAY BE DETECTED THROUGH ROUTINE MAINTENANCE TASKS.
2. PROBABILITY DATA FOR THE SYSTEM COMPONENT OR A LOGISTICALLY SIMILAR SYSTEM/COMPONENT, FROM PROCESS 301.2.4.2.3A1, THAT INDICATES A HIGH PROBABILITY THAT THE

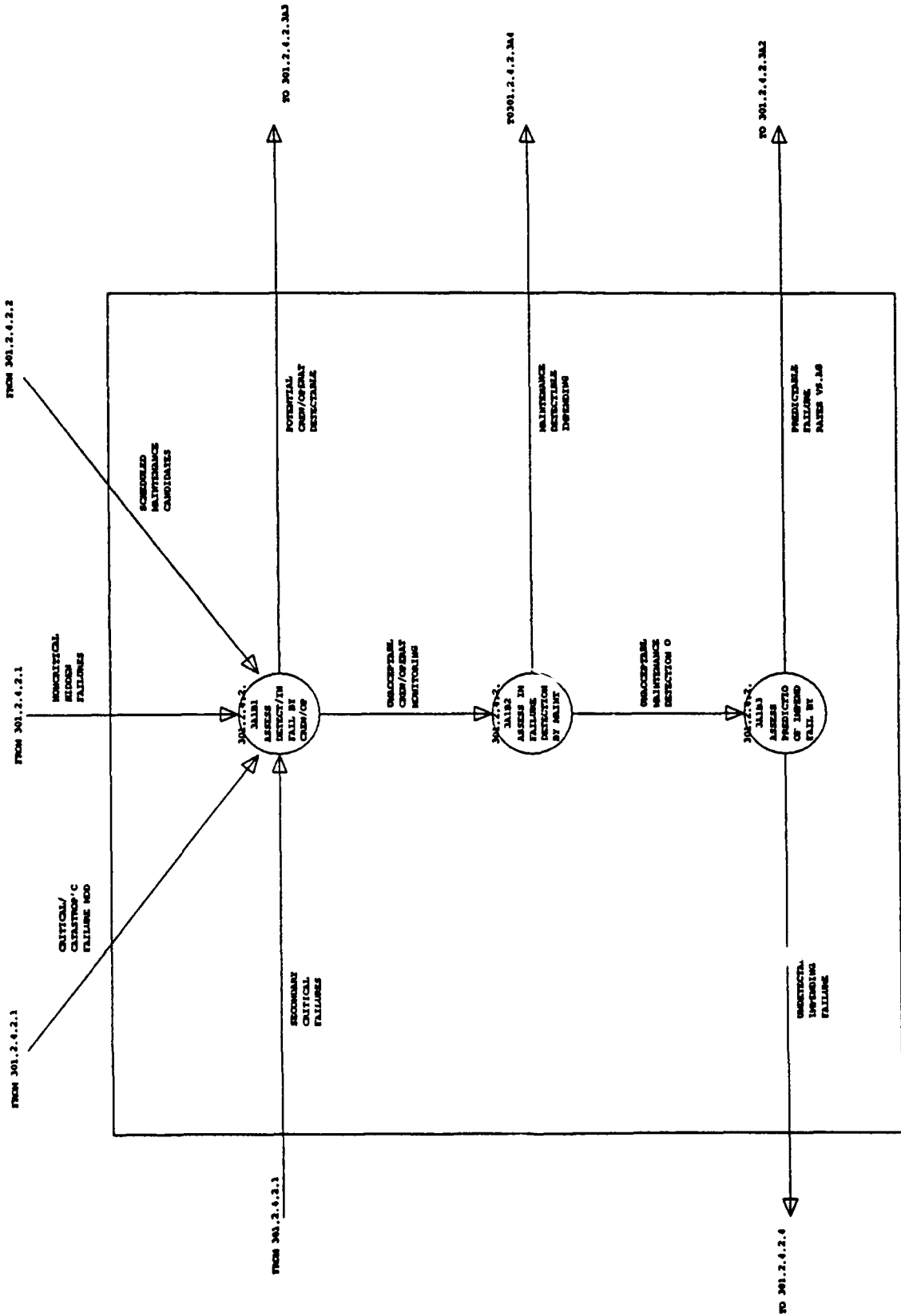

301.2.4.2.3.M3
 Created by: AK
 Revised by: Jue
 Date changed: 11-18-88

FAILURE MODE UNDER ANALYSIS CAN BE DETECTED WITH SUFFICIENT LEADTIME BEFORE ACTUAL FAILURE OCCURS MUST BE RECORDED IN THE LSAR RECORD B, CARD B1, BLOCK 5A.

PROCESS 301.2.4.2.3A1B1
ASSESS DETECTION OF IMPENDING FAILURE
BY CREW/OPERATOR MONITORING

OBJECTIVE:

THE USER MUST INVESTIGATE THE PROCESS WHERE THE CREW/OPERATOR DETECTS EITHER EXPERIENCED OR IMPENDING FAILURE THROUGH ROUTINE MONITORING OF THE OPERATION.

EXPERIENCED AND IMPENDING FAILURES ARE DETECTABLE DIRECTLY, BY THE CREW/OPERATOR, THROUGH THE HUMAN SENSES (SOUND, TOUCH, SIGHT, ETC.), OR INDIRECTLY, THROUGH THE INCORPORATION OF DESIGN FEATURES SUCH AS BUILT-IN TEST EQUIPMENT AND SENSORS/TRANSDUCERS (WARNING LIGHTS, GAUGES, ETC.)

PROCEDURE:

1. USE CRITICAL, SECONDARY CRITICAL, AND NONCRITICAL HIDDEN FAILURE MODES FROM TASK 301.2.4.2.1 AND SCHEDULED MAINTENANCE CANDIDATES FROM TASK 301.2.4.2.2 AND PROCEED TO ACTION ITEM #2.

2. IF FAILURE MODE FOR THE SYSTEM/COMPONENT OR LOGISTICALLY SIMILAR SYSTEM COMPONENT CAN BE DETECTED BY THE CREW/OPERATOR USING BUILT-IN TEST EQUIPMENT, SENSORS/TRANSDUCERS OR THROUGH THE HUMAN SENSES THEN, PROCEED

TO PROCESS 301.2.4.2.3A3 TO ASSESS LEADTIME DETECTION TO FAILURE.

3. IF DATA INDICATES THAT FAILURE MODE CANNOT BE CONFIDENTLY DETECTED BY CREW/OPERATOR, PROCEED TO PROCESS 301.2.4.2.3A1B2 FOR INVESTIGATING DETECTABILITY OF FAILURE MODE DURING A SCHEDULED MAINTENANCE FUNCTION.

PROCESS 301.2.4.2.3A1B2
ASSESS IMPENDING FAILURE DETECTION BY MAINTENANCE

OBJECTIVE:

THE USER MUST INVESTIGATE AND ANALYZE THE FAILURE DISTRIBUTIONS OF THE SYSTEM/COMPONENT UNDER ANALYSIS.

A. THE FIRST DISTRIBUTION SHOULD RELATE TO THE TIME UNTIL EVIDENCE OF IMMINENT FAILURE CAN BE DETECTED.

B. THE SECOND DISTRIBUTION DEALS WITH THE TIME FROM ONSET TO OCCURRENCE OF THE FAILURE.

THE OBJECTIVE OF A SCHEDULED MAINTENANCE, IN THIS INSTANCE, IS TO SCHEDULE THE INSPECTIONS SO THAT THERE IS A VERY LOW PROBABILITY THAT A FAILURE WILL OCCUR BETWEEN INSPECTIONS.

PROCEDURE:

1. USE THOSE SYSTEM/COMPONENTS FROM PROCESS 301.2.4.2.3A1B1 WHOSE POTENTIAL FAILURE CANNOT BE DETECTABLE BY CREW/OPERATOR WITH THE USE OF GAUGES, WARNING LIGHTS, ETC. AND/OR BY OPERATIONAL CHARACTERISTICS (VIBRATION, SOUND, ETC.).

2. IF THE PROBABILITY OF FAILURE DATA INDICATES THAT THE FAILURE ONSET WILL OCCUR, AND THE ONSET WILL GO TO FAILURE ALL WITHIN THE INSPECTION INTERVAL AND THUS CAN BE DETECTED, PROCEED TO PROCESS 301.2.4.2.3A4 AND RECORD DATA IN THE LSAR.

3. IF THERE IS A VERY HIGH PROBABILITY THAT A FAILURE WILL OCCUR BETWEEN MAINTENANCE INSPECTIONS PROCEED TO PROCESS 301.2.4.2.3A1B3 TO ASSESS FAILURE PREDICTIONS BY USING AGE/USAGE DATA.

PROCESS 301.2.3.2.3A1B3
ASSESS PREDICTION OF IMPENDING FAILURE BY AGE/USAGE

OBJECTIVE:

THE USER MUST ANALYZE AND INVESTIGATE THE RELIABILITY CHARACTERISTICS OF THE SYSTEM/COMPONENT UNDER ACTUAL OPERATING CONDITIONS, WHICH BEGINS THE DAY A NEW ITEM ENTERS SERVICE.

THIS PROCESS INCLUDES MONITORING THE CONDITION AND PERFORMANCE OF EACH ITEM, ANALYZING FAILURE DATA TO IDENTIFY PROBLEMS AND THEIR CONSEQUENCES, EVALUATING INSPECTION FINDINGS TO ADJUST TASK INTERVALS, AND DETERMINING AGE RELIABILITY RELATIONSHIPS FOR VARIOUS ITEMS.

PROCEDURE:

1. USE THOSE FAILURES FROM PROCESS 301.2.4.2.3A1B2 THAT CANNOT BE DETECTED DURING AN ASSIGNED MAINTENANCE FUNCTION.

2. IF FAILURE RATE DATA FOR THE SYSTEM/COMPONENT OR LOGISTICALLY SIMILAR SYSTEM/COMPONENT INDICATES THAT THE

FROM TASK 301.2.4.2.3

FROM TASK 301.2.4.2.3

301.2.4.2.4A
LBA DAT
MCCO B
PAM DALS

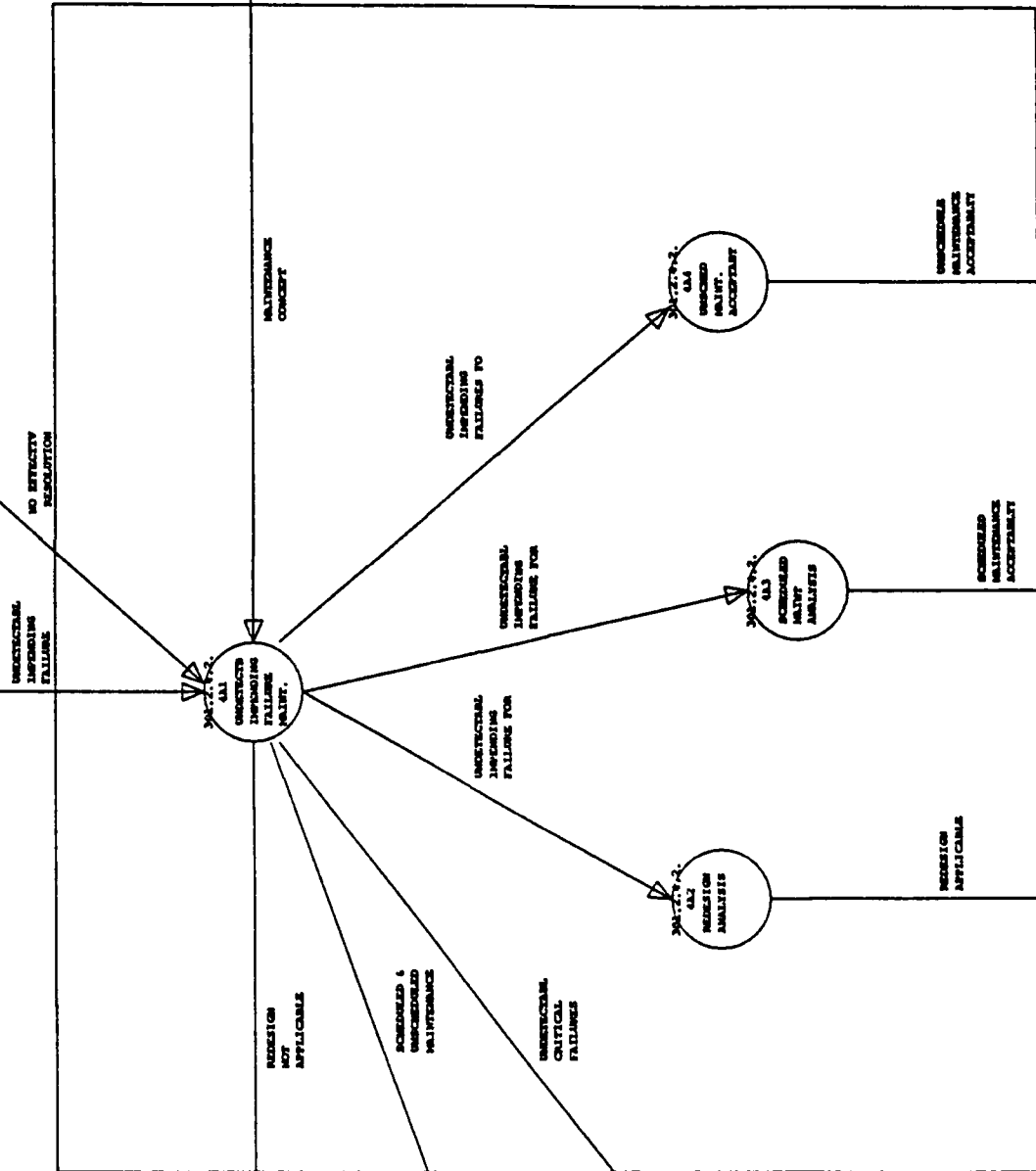

301.2.4.2.4A
Created by: JTS
Revised by: JTS
Date changed: 21-10-88

1/8/81/30/C
T-REC'D B
CAND 01
BLK 10

1/8/81/30/A
T-REC'D B
CAND 01
BLK 10

1/8/81/30/E
T-REC'D B
CAND 01
BLK 10

PROBABILITY OF FAILURE OCCURS DURING A SPECIFIED RANGE OF CALENDAR TIME, OPERATING HOURS, MILES, ROUNDS, OR CYCLES THEN, A REMOVE AND REPLACEMENT MAINTENANCE CAN BE ESTABLISHED AND THEREFORE, PROCEED TO PROCESS 301.2.4.2A2.

3. IF FAILURE RATE DATA IS INDEPENDENT OF EITHER CALENDAR TIME OR USAGE THEN, PROCEED TO PROCESS 301.2.4.2.4.

4. PROCESS 301.2.3.2.4 - UNDETECTABLE IMPENDING FAILURE ANALYSIS.

PROCESS 301.2.4.2.4A1
UNDETECTABLE IMPENDING FAILURE MAINTENANCE ANALYSIS

OBJECTIVE:

THE USER MUST ANALYZE DATA FOR UNDETECTABLE IMPENDING FAILURES AND HISTORICAL MAINTENANCE CONCEPTS FOR THE SYSTEM/COMPONENT OR LOGISTICALLY SIMILAR SYSTEM/COMPONENT AND ASSIGN THE APPROPRIATE MAINTENANCE ACTION TO MEET REQUIRED MAINTENANCE SAFETY LEVELS.

PROCEDURE:

1. OBTAIN THE MAINTENANCE CONCEPTS FROM LSAR RECORD B, CARD B10, BLOCK 4 AND REVIEW BASIS FOR MAINTENANCE PLAN FOR THE SYSTEM/COMPONENT UNDER ANALYSIS.

2. USE THOSE UNDETECTABLE IMPENDING FAILURES IDENTIFIED IN PROCESS 301.2.4.2.3 AND DEVELOP A (SCHEDULED OR UNSCHEDULED) MAINTENANCE PROGRAM FOR FURTHER REVIEW BASED ON MAINTENANCE CONCEPTS FROM ITEM #1.

3. IF DATA INDICATES THAT A SCHEDULED MAINTENANCE MAY RESTORE SAFETY AND MISSION REQUIREMENTS THEN, PROCEED TO PROCESS 301.2.4.2.4A3.

4. IF DATA INDICATES THAT THE FAILURE OR EFFECTS OF THE FAILURE CAN BE TOLERATED, PROCEED TO PROCESS 301.2.4.2.3A4.

5. IF DATA INDICATES DIFFICULTIES IN DEVELOPING A CONSISTENT MAINTENANCE PLAN THEN, PROCEED TO PROCESS 301.2.4.2.4A2 FOR CONSIDERATION OF REDESIGN.

PROCESS 301.2.4.2.4A2
REDESIGN ANALYSIS

OBJECTIVE:

THE USER SHALL INVESTIGATE THE MAINTENANCE PROGRAM FOR EACH FAILURE TO ENSURE THAT IT WILL MEET THE REQUIRED MISSION AND SAFETY LEVELS.

IF THE USER INDICATES THAT THE MAINTENANCE TASKS WILL NOT MEET THE REQUIREMENTS OF THE SYSTEM/COMPONENT, REDESIGN SHOULD BE CONSIDERED.

PROCEDURE:

1. OBTAIN THOSE UNDETECTABLE FAILURES, FROM PROCESS 301.2.4.2.4A1, FOR WHICH NO APPROPRIATE MAINTENANCE TASK SATISFIES THE REQUIREMENTS.

2. REVIEW DESIGN CHARACTERISTICS FROM THE PROGRAM MANAGER'S DATA FILE FOR THE SYSTEM/COMPONENT AND INDICATE IF REDESIGN IS TECHNICALLY AND ECONOMICALLY JUSTIFIABLE.

3. ENTER APPLICABLE REDESIGN DATA IN THE LSAR RECORD B, CARD B1, BLOCK 5A.

4. IF REDESIGN IS NOT APPLICABLE, EVALUATE ALTERNATIVE SOLUTIONS USING MORE MATURE DATA FROM A LOGISTICALLY SIMILAR SYSTEM/COMPONENT AND REEVALUATING PROCESS AT PROCESS 301.2.4.2.1

PROCESS 301.2.4.2.4A3
SCHEDULED MAINTENANCE ANALYSIS

OBJECTIVE:

ONCE THE USER HAS DETERMINED THAT SCHEDULED MAINTENANCE IS REQUIRED, EACH FAILURE MUST BE EVALUATED TO DETERMINE WHICH INSPECTION TASK INTERVAL WILL BE APPLICABLE AND MOST COST EFFECTIVE. THIS WILL BE DONE AS FOLLOWS:

PROCEDURE:

1. USE THOSE FAILURES, FROM PROCESS 301.2.4.2.4A1, FOR WHICH A SCHEDULED MAINTENANCE IS APPLICABLE.

2. DETERMINE THE MOST COST EFFECTIVE INSPECTION INTERVAL
C(Ti) USING THE FOLLOWING EQUATION:

$$C(Ti) = [Ci + Cfu(F(Ti))]/Ti$$

Where:

C(Ti) = Expected Cost per Unit Time

Ci = Cost of Inspection

Cfu = Cost of an Undetected Failure (i.e., Cost of the End Item operating in a Degraded Mode).

F(Ti) = Expected number of failures in Inspection Interval Ti

Ti = Inspection Interval

3. ENTER ACCEPTABLE DATA IN LSAR RECORD B, CARD B1,
BLOCK 5B.

PROCESS 301.2.4.2.4A4
UNSCHEDULED MAINTENANCE ACCEPTABILITY

OBJECTIVE:

THE USER MUST IDENTIFY THOSE FAILURES THAT ARE DETECTABLE BY THE CREW/OPERATOR EITHER AT THE TIME OF OCCURRENCE OR AFTER OCCURRENCE SO THAT UNSCHEDULED MAINTENANCE CAN BE ACCOMPLISHED IN THE EVENT OF FAILURE. IDENTIFICATION IS BASED ON PROBABILITY OF FAILURE, FAILURE DETECTION, RATE, PREDICTABILITY AND CRITICALITY.

IT IS IMPORTANT TO NOTE THAT THE FAILURE OR EFFECTS OF THE FAILURE MUST BE TOLERABLE.

PROCEDURE:

1. OBTAIN THOSE FAILURES IDENTIFIED AS BEING ACCEPTABLE CANDIDATES FOR AN UNSCHEDULED MAINTENANCE TASK FROM PROCESS 301.2.4.2.2A1.

2. IF FAILURE DOES NOT CAUSE A SAFETY HAZARD, BUT RATHER CAUSES A MISSION FAILURE, IDENTIFY THE FAILURE AS TOLERABLE AND ENTER DATA INTO THE LSAR RECORD B, CARD B1, BLOCK 5B.

5. PROCESS 301.2.4.2.5 - DETECTABLE FAILURE ASSESSMENT.

PROCESS 301.2.4.2.5A1
DETECTABLE FAILURE ANALYSIS

OBJECTIVE:

THE USER MUST IDENTIFY THOSE FAILURES THAT CAN BE DETECTED IF THE PROBABILITY OF COMPONENT FAILURE INCREASES AS CALENDAR TIME OR USAGE INDICATORS INCREASE. FOR THESE ITEMS, A SCHEDULED REMOVAL, REPLACEMENT OR OVERHAUL OF ITEM WILL RETURN THE SYSTEM/COMPONENT TO ITS ORIGINAL LEVEL.

PROCEDURE:

1. OBTAIN FAILURE CHARACTERISTICS DATA (PROBABILITY OF FAILURE, FAILURE RATES, FAILURE DETECTION, CRITICALITY) FOR SYSTEM/COMPONENT UNDER ANALYSIS FROM PROCESS 301.2.4.2.3.

2. BASED ON RESULTS OF FAILURE CHARACTERISTICS DATA, DETERMINE THE APPROPRIATE MAINTENANCE ACTION TO BE FURTHER ANALYZED AS FOLLOWS:

A. IF THE SYSTEM/COMPONENT SHOWS INDICATIONS OF WEAROUT THEN, PROCEED TO PROCESS 301.2.4.2.5A2 FOR FURTHER REVIEW.

B. THE SYSTEM/COMPONENT SURVIVES TO A SPECIFIED AGE AND IF IT IS POSSIBLE TO DEFINE POTENTIAL FAILURE CONDITIONS BY AN EXPLICIT TASK THEN, PROCEED TO PROCESS 301.2.4.2.5A3.

C. IF THE SYSTEM/COMPONENT EXPERIENCED OR IMPENDING FAILURE CAN BE DETECTED BY CREW MONITORING THEN, PROCEED TO PROCESS 301.2.4.2.5A4 FOR FURTHER REVIEW.

PROCESS 301.2.4.2.5A2
REPLACE/OVERHAUL ANALYSIS

OBJECTIVE:

THE USER MUST IDENTIFY THOSE CRITICAL AND HIDDEN COMPONENTS THAT EXHIBIT WEAR-OUT CHARACTERISTICS WHERE IMPENDING FAILURE CAN BE DETECTED. THEIR INHERENT RELIABILITY AND SAFETY LEVELS CAN BE PRESERVED BY EITHER A RESTORATION OR DISCARD TASK. EACH OF THE TWO ALTERNATIVES MUST BE ANALYZED IN TERMS OF COST AND THE RELIABILITY AND SAFETY LEVELS THAT CAN BE MAINTAINED UNDER EACH ALTERNATIVE.

PROCEDURE:

1. OBTAIN THOSE POTENTIAL FAILURES FOR WHICH INSPECTION/TESTS OR UNIT MAINTENANCE ARE NOT FEASIBLE FROM A SAFETY OR COST-EFFECTIVE STANDPOINT FROM PROCESS 301.2.4.2.5A1.

2. USE MIL-STD-882 AND/OR AR 385-55 AS A GUIDE FOR ENSURING SAFETY CONSIDERATIONS.

3. DETERMINE THE REPLACE INTERVAL (T_r) USING THE FOLLOWING COST EQUATION:

$$C(T_r) = (C_{pr} + C_f(F(T_r)/T_r)$$

Where:

$C(T_r)$ = Expected Cost per Unit Time.

C_{pr} = Cost of a Preventive Replacement.

C_f = Cost of a Failure (includes Cost of Part Replacement and System Downtime).

$F(T_r)$ = Expected number of failures in replace interval T_r .

4. ENTER DATA IN LSAR RECORD B, CARD B1, BLOCK 5B.

PROCESS 301.2.4.2.5A3
SERVICE/OVERHAUL ANALYSIS

OBJECTIVE:

THE USER MUST INVESTIGATE THE COST EFFECTIVENESS OF A SCHEDULED LUBRICATION OR SERVICE FUNCTION AND IDENTIFY THOSE RESPONSIBLE FOR PERFORMING THE PRESCRIBED TASK (I.E., CREW/OPERATOR OR HIGHER MAINTENANCE LEVEL - ORGANIZATION OR INTERMEDIATE SUPPORT.

PROCEDURE:

1. OBTAIN THOSE POTENTIAL FAILURES FROM PROCESS 301.2.4.2.5A1 FOR WHICH LUBRICATION OR SERVICE WILL POSSIBLY RESTORE ORIGINAL FAILURE RESISTANCE.

2. DETERMINE THE SERVICE/OVERHAUL INTERVAL (Ts) AND COST EFFECTIVENESS BY USING THE FOLLOWING EQUATION:

$$C(Ts) = [Cs + Cfs(Ti)fs]/Ti$$

C(Ts) = Cost per Unit Time

Cs = Cost of a Service

Cis = Cost to the Mission per Unit Time due to End Item Operating in a Degraded Mode.

(Ti)fs = Expected Age Limit that a Conditional Failure would go Undetected in Inspection Interval Ti.

Ti = Inspection Interval

PROCESS 301.2.4.2.5A4
CREW/MONITORING ANALYSIS

OBJECTIVE:

THE USER SHALL IDENTIFY EXPERIENCED OR IMPENDING FAILURES THROUGH ROUTINE CREW MONITORING OF THE OPERATION AND USE OF THE ITEM. THE FAILURE SHOULD BE DETECTABLE BY CREW/OPERATOR THROUGH THE HUMAN SENSES OR DIRECTLY THROUGH THE INCORPORATION OF BUILT-IN TEST EQUIPMENT AND SENSOR/TRANSDUCER DEVICES.

THE COST OF CREW/OPERATOR MONITORING MUST BE DETERMINED FOR FAILURES SO THAT A COMPARISON TO SCHEDULED AND HARD TIME CAN BE MADE.

PROCEDURE:

1. OBTAIN THOSE EXPERIENCE FAILURES FROM PROCESS 301.2.4.2.5A4 THAT ARE DETECTABLE BY THE OPERATOR/CREW WHEN OR AFTER THEY OCCUR.

2. DETERMINE THE COST EFFECTIVENESS FOR OPERATOR/CREW MONITORING BY USING THE FOLLOWING FORMULA:

$$C(Cm) = (Crd/Na + Cm) + (Cfu \times Ftu)$$

Where:

C(Cm) = Expected Cost of Undetected Failures in Life of System for Crew Monitoring.

Crd = Cost of Research & Development for Monitoring System

Na = Number of Weapon Systems/End Items to be Acquired

Cm = Cost of Monitoring System

Cfu = Cost of Undetected Failure

Ftu = Number of Failures Undetected over the Life of the System.

3. ENTER DATA INTO THE LSAR RECORD B, CARD B1, BLOCK 5A.