

AD-A259 615

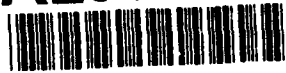

FINAL REPORT
JANUARY 1992

REPORT NO. 91-02

TRANSPORTABILITY TESTS OF
VARIOUS COMBAT CONFIGURED
LOADS (CCLs) ON THE
PALLETIZED LOADING SYSTEM
(PLS) TRUCK/TRAILER



1-283

93-01035



SSP8

SDTIC
ELECTE
JAN 21 1993
E D

Prepared for:
U.S. Army Defense Ammunition
Center and School
ATTN: SMCAC-DET
Savanna, IL 61074-9639

Distribution Unlimited



U.S. ARMY
ARMAMENT
MUNITIONS
CHEMICAL COMMAND

U.S. ARMY DEFENSE AMMUNITION
CENTER AND SCHOOL

VALIDATION ENGINEERING DIVISION
SAVANNA, ILLINOIS 61074-9639

08 1 21 005

AVAILABILITY NOTICE

A copy of this report will be furnished each attendee on automatic distribution. Additional copies or authority for reprinting may be obtained by written request from Director, U.S. Army Defense Ammunition Center and School, ATTN: SMCAC-DEV, Savanna, IL 61074-9639.

DISTRIBUTION INSTRUCTIONS

Destroy this report when no longer needed. Do not return.

Citation of trade names in this report does not constitute an official endorsement.

The information contained herein will not be used for advertising purposes.

REPORT DOCUMENTATION PAGE				Form Approved OMB No. 0704-0188	
1a. REPORT SECURITY CLASSIFICATION UNCLASSIFIED		1b. RESTRICTIVE MARKINGS			
2a. SECURITY CLASSIFICATION AUTHORITY		3. DISTRIBUTION / AVAILABILITY OF REPORT UNLIMITED			
2b. DECLASSIFICATION / DOWNGRADING SCHEDULE					
4. PERFORMING ORGANIZATION REPORT NUMBER(S) 91-02		5. MONITORING ORGANIZATION REPORT NUMBER(S)			
6a. NAME OF PERFORMING ORGANIZATION U.S. Army Defense Ammunition Center and School		6b. OFFICE SYMBOL <i>(if applicable)</i> SMCAC-DEV	7a. NAME OF MONITORING ORGANIZATION		
6c. ADDRESS <i>(City, State, and ZIP Code)</i> ATTN: SMCAC-DEV Savanna, IL 61074-9639		7b. ADDRESS <i>(City, State, and ZIP Code)</i>			
8a. NAME OF FUNDING / SPONSORING ORGANIZATION U.S. Army Defense Ammunition Center and School		8b. OFFICE SYMBOL <i>(if applicable)</i> SMCAC-DET	9. PROCUREMENT INSTRUMENT IDENTIFICATION NUMBER		
8c. ADDRESS <i>(City, State, and ZIP Code)</i> ATTN: SMCAC-DET Savanna, IL 61074-9639		10. SOURCE OF FUNDING NUMBERS			
		PROGRAM ELEMENT NO.	PROJECT NO.	TASK NO.	WORK UNIT ACCESSION NO.
11. TITLE <i>(Include Security Classification)</i> Transportability Test of Various Combat Configured Loads (CCLs) on the Palletized Loading System (PLS) Truck/Trailer					
12. PERSONAL AUTHOR(S) A. C. McIntosh					
13a. TYPE OF REPORT Final		13b. TIME COVERED FROM _____ TO _____		14. DATE OF REPORT <i>(Year, Month, Day)</i> 1992 January	15. PAGE COUNT
16. SUPPLEMENTARY NOTATION					
17. COSATI CODES			18. SUBJECT TERMS <i>(Continue on reverse if necessary and identify by block number)</i>		
FIELD	GROUP	SUB-GROUP			
19. ABSTRACT <i>(Continue on reverse if necessary and identify by block number)</i> The U.S. Army Defense Ammunition Center and School (USADACS) was tasked by USADACS, Transportation Engineering Division (SMCAC-DET), to test various Combat Configured Loads (CCLs) on the Palletized Loading System (PLS) truck/trailer. The test loads were made up of weighted inert materiel and consisted of artillery, propellant charges, and Multiple Launch Rocket System (MLRS) pods. The proposed ammunition tiedown methods were adequate in restraining all loads when subjected to standard road transportation tests.					
20. DISTRIBUTION / AVAILABILITY OF ABSTRACT <input checked="" type="checkbox"/> UNCLASSIFIED/UNLIMITED <input type="checkbox"/> SAME AS RPT. <input type="checkbox"/> DTIC USERS			21. ABSTRACT SECURITY CLASSIFICATION UNCLASSIFIED		
22a. NAME OF RESPONSIBLE INDIVIDUAL JEROME H. KROHN		22b. TELEPHONE <i>(Include Area Code)</i> 815-273-8929		22c. OFFICE SYMBOL SMCAC-DEV	

U.S. ARMY DEFENSE AMMUNITION CENTER AND SCHOOL
VALIDATION ENGINEERING DIVISION
SAVANNA, IL 61074-9639

REPORT NUMBER 91-02

TRANSPORTABILITY TESTS OF VARIOUS COMBAT CONFIGURED LOADS (CCLs)
ON THE PALLETIZED LOADING SYSTEM (PLS) TRUCK/TRAILER

TABLE OF CONTENTS

PART	PAGE NO.
1. INTRODUCTION	1-1
A. BACKGROUND.....	1-1
B. AUTHORITY.....	1-1
C. OBJECTIVE.....	1-1
D. CONCLUSION	1-1
2. ATTENDEES	2-1
3. TEST PROCEDURES	3-1
4. TEST RESULTS.....	4-1
5. PHOTOGRAPHS	5-1
6. DRAWINGS	6-1

PART 1

INTRODUCTION

A. **BACKGROUND.** The U.S. Army Defense Ammunition Center and School (USADACS), Validation Engineering Division (SMCAC-DEV), was tasked by USADACS, Transportation Engineering Division (SMCAC-DET), to test Combat Configured Loads (CCLs) on the Palletized Loading System (PLS) truck/trailer. The tactical loads were designed to be used in a tactical environment as part of the acceptance of the production version of the PLS.

B. **AUTHORITY.** This test was conducted IAW mission responsibilities delegated by U.S. Army Armament, Munitions and Chemical Command (AMCCOM), Rock Island, IL. Reference is made to Change 4, 4 October 1974, to AR 740-1, 23 April 1971, Storage and Supply Activity Operations; AMCCOMR 10-17. 13 January 1986, Mission and Major Functions of USADACS.

C. **OBJECTIVE.** The objective of this test was to verify six tactical load configurations for the PLS flatrack. These loads consist of an artillery CCL, a 25 percent CCL, and Multiple Launch Rocket System (MLRS) pods in configurations of four, three, two, and one pod(s).

D. **CONCLUSIONS.** All loads were successfully transported through the road transportation course; however, not without modifications. The CCL required reconfiguring the load with the artillery projectiles at the rear of the pallet and the propellant charges at the front. This was necessary for removal of the flatrack from the PLS trailer. In the case of the MLRS loads, it was found that support assemblies were required to reduce lateral load movement, reduce point loading on the flatrack deck and prevent the skids from deforming. If the support devices are not used, the flatrack deck and MLRS skids can be damaged.

PART 2

ATTENDEES

A. C. McIntosh
DSN 585-8989
815-273-8989
E-Mail address: amcintos@savanna-emh1.army.mil

Director
U.S. Army Defense Ammunition Center
and School
ATTN: SMCAC-DEV
Savanna, IL 61074-9639

John Simons
DSN 585-8074
815-273-8074

Director
U.S. Army Defense Ammunition Center
and School
ATTN: SMCAC-DET
Savanna, IL 61074-9639

DTIC QUALITY INSPECTED 8

Accession For	
NTIS CRA&I	<input checked="" type="checkbox"/>
DTIC TAB	<input type="checkbox"/>
Unannounced	<input type="checkbox"/>
Justification	
By	
Distribution/	
Availability Codes	
Dist	Avail and/or Special
A-1	

PART 3

TEST PROCEDURES

These test procedures were extracted from TP-91-01, Transportability Testing Procedures, July 1991.

A. Road Hazard Course. This step required the CCLs on flatrack to be transported on a PLS truck/trailer driven over the 200-foot-long segment of concrete paved road, which consists of two series of railroad ties projecting 6 inches above the level of the road surface. The truck/trailer combination traversed this course two times (figure no. 1).

B. Road Trip. The PLS truck/trailer was used to transport the CCLs for a distance of 30 miles over a combination of roads surfaced with gravel, concrete, or asphalt. The test route included curves, corners, railroad crossings, cattle guards, stops and starts. The PLS traveled at the maximum speed suitable for the particular road being traversed, except as limited by legal restrictions. Upon completion of the 30-mile road trip, the loaded PLS truck/trailer was subjected to three full airbrake stops while traveling in the forward direction and one in the reverse direction. The first three stops were at 5, 10, and 15 mph, while the stop in the reverse direction was approximately 5 mph.

C. Washboard Course. The PLS truck/trailer, with CCLs on flatrack, was driven over the washboard course (figure no. 2) at a speed which produced the most violent response in the test load. The washboard course was constructed as shown in figure no.

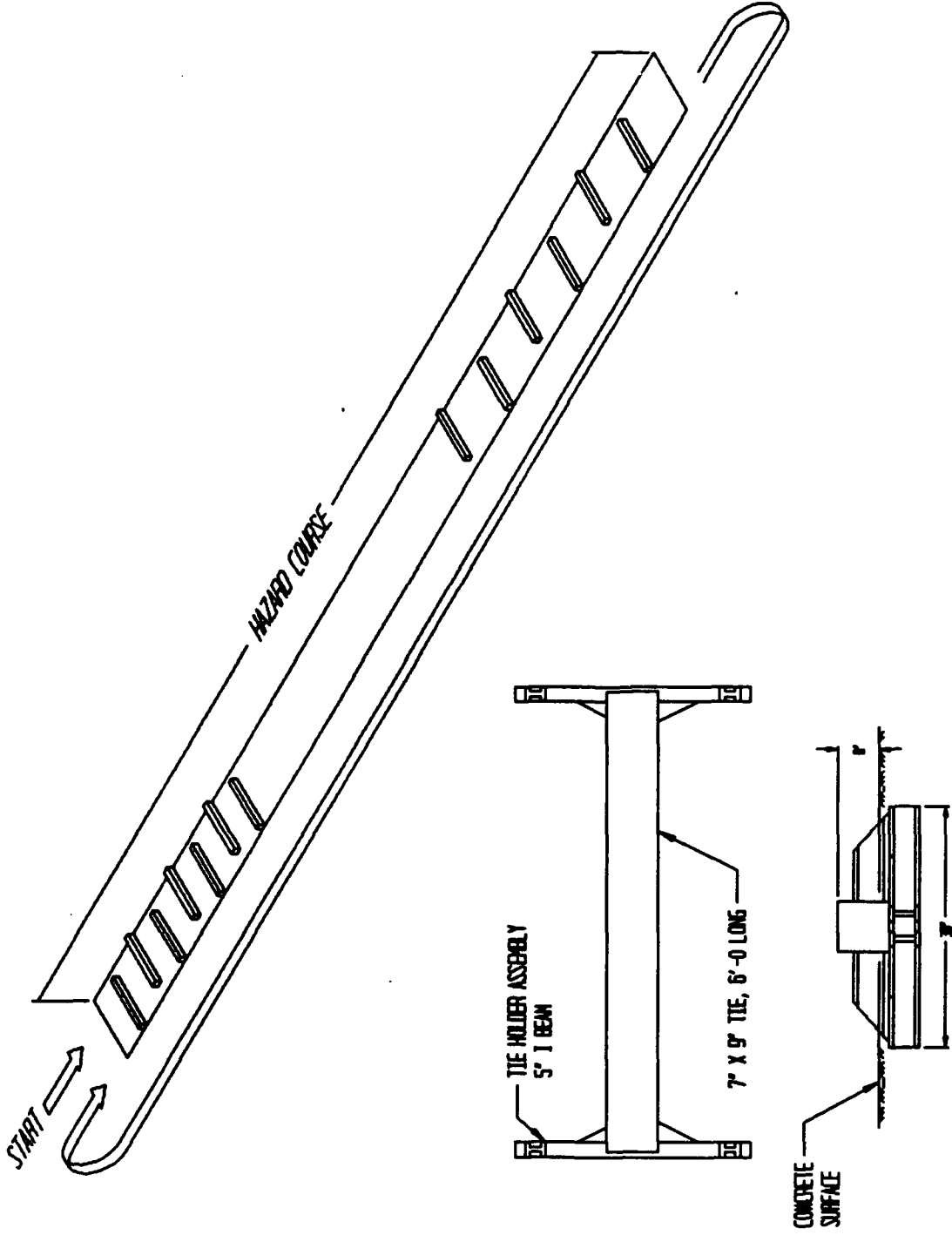

TIE HOLDER DETAILS

FIGURE 1

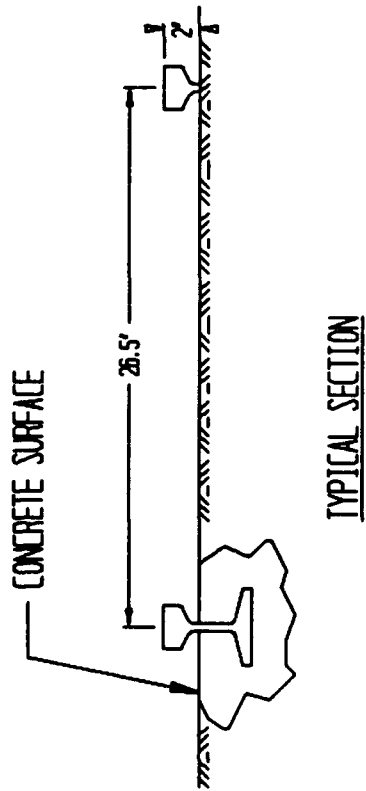
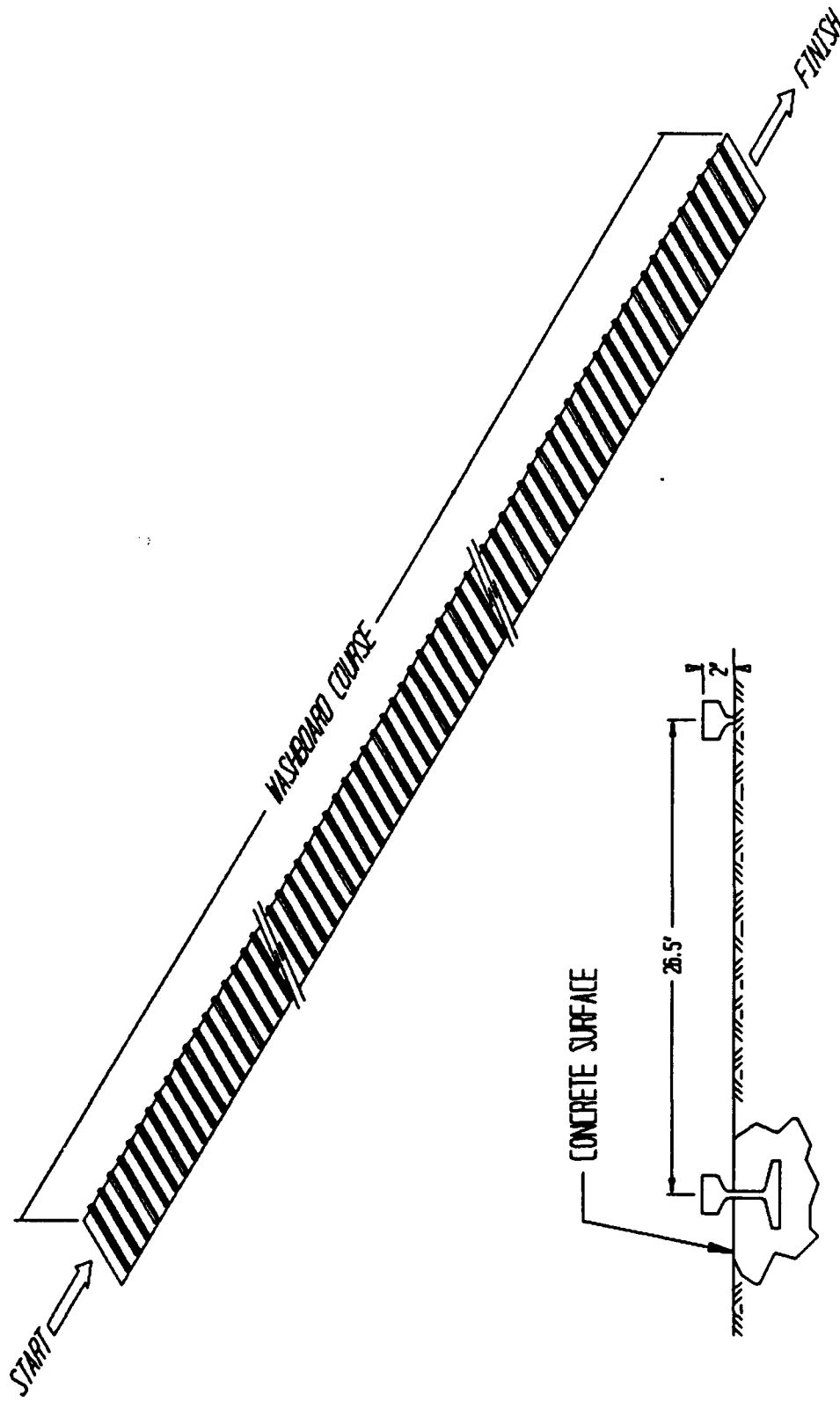

FIGURE 2

PART 4

TEST RESULTS

TEST SPECIMEN AND RESULTS

ROAD TEST DATA

TEST NO. 1

DATE: 16 SEP 91

TEST SPECIMEN: Maximum load of 155mm pallet units on truck and 1/4 CCL on the PLS trailer.

ROAD HAZARD COURSE.

PASS 1-A OVER FIRST SERIES OF TIES 0.11 MIN 5.16 MPH

PASS 1-B OVER FIRST SERIES OF TIES 0.10 MIN 5.68 MPH

REMARKS: Pallets on trailer shifted 4-3/8 inch. No movement of 155MM pallets on truck.

PASS 2-A OVER FIRST SERIES OF TIES 0.09 MIN 6.31 MPH

PASS 2-B OVER FIRST SERIES OF TIES 0.10 MIN 6.68 MPH

REMARKS: Deteriorated pallet post collapsed on truck.

30 MILE ROAD TEST: No movement of load on truck or trailer.

PANIC STOP TEST: No movement of load on truck or trailer.

PASS 3-A OVER FIRST SERIES OF TIES 0.10 MIN 5.68 MPH

PASS 3-B OVER FIRST SERIES OF TIES 0.09 MIN 6.31 MPH

REMARKS: Perimeter pallets returned to within one inch of original position on trailer.

PASS 4-A OVER FIRST SERIES OF TIES 0.09 MIN 6.31 MPH

PASS 4-B OVER FIRST SERIES OF TIES 0.10 MIN 5.68 MPH

REMARKS: Rear strap on CCL loosened up. Pallet post collapsed. Trailer load remained intact.

WASHBOARD COURSE: Propelling charge containers cut into 155mm pallet base. No movement of 155mm load on truck.

REMARKS: Total weight of 155mm pallets on the PLS truck was too heavy for the load handling system to remove it. Weight of the 155mm load is 34,900 pounds, which is within limits of the PLS lifting requirements (33,000 payload + 3,200 pounds flatrack). Load geometry placed a heavier torque on the lifting arm. Reconfiguring the test load distributed the weight so the truck could lift the flatrack from the truck.

:

:

ROAD TEST DATA

TEST NO. 2

DATE: 17 SEP 91

TEST SPECIMEN: PLS truck with 25 percent CCL of propelling charges, 155mm projectiles, fuses, and primers.

ROAD HAZARD COURSE.

PASS 1-A OVER FIRST SERIES OF TIES	0.09 MIN	6.31 MPH
PASS 1-B OVER FIRST SERIES OF TIES	0.10 MIN	5.68 MPH

REMARKS: No load movement.

PASS 2-A OVER FIRST SERIES OF TIES	0.09 MIN	6.31 MPH
PASS 2-B OVER FIRST SERIES OF TIES	0.10 MIN	5.68 MPH

REMARKS: No load movement.

30 MILE ROAD TEST: No load movement.

PANIC STOP TEST: No load movement.

PASS 3-A OVER FIRST SERIES OF TIES	0.11 MIN	5.16 MPH
PASS 3-B OVER FIRST SERIES OF TIES	0.09 MIN	6.31 MPH

REMARKS: No load movement.

PASS 4-A OVER FIRST SERIES OF TIES	0.10 MIN	5.68 MPH
PASS 4-B OVER FIRST SERIES OF TIES	0.09 MIN	6.31 MPH

REMARKS: No load movement.

WASHBOARD COURSE: No load movement greater than 1/2-inch. Metal pallets cutting into wood pallets at interface. Pallet load weight 13,780 pounds.

ROAD TEST DATA

TEST NO. 3

DATE: 17 SEP 91

TEST SPECIMEN: 155mm pallets loaded from aft toward front of PLS flatrack on PLS truck.

ROAD HAZARD COURSE.

PASS 1-A OVER FIRST SERIES OF TIES	0.10 MIN	5.68 MPH
PASS 1-B OVER FIRST SERIES OF TIES	0.09 MIN	6.31 MPH

REMARKS: No load movement. Tiedown straps remained tight.

PASS 2-A OVER FIRST SERIES OF TIES	0.10 MIN	5.68 MPH
PASS 2-B OVER FIRST SERIES OF TIES	0.10 MIN	5.68 MPH

REMARKS: No load movement. Tiedown straps remained tight.

30 MILE ROAD TEST: No movement in load position on flatrack.

PANIC STOP TEST: No movement in load position on flatrack.

PASS 3-A OVER FIRST SERIES OF TIES	0.09 MIN	6.31 MPH
PASS 3-B OVER FIRST SERIES OF TIES	0.10 MIN	5.68 MPH

REMARKS: No load movement. Tiedown straps remained tight.

PASS 4-A OVER FIRST SERIES OF TIES	0.09 MIN	6.31 MPH
PASS 4-B OVER FIRST SERIES OF TIES	0.09 MIN	6.31 MPH

REMARKS: No load movement.

WASHBOARD COURSE: No load movement. Tiedown straps remained tight.

ROAD TEST DATA

TEST NO. 4

DATE: 10 DEC 91

TEST SPECIMEN: Four MLRS pods on PLS truck and trailer.

ROAD HAZARD COURSE.

PASS 1-A OVER FIRST SERIES OF TIES	0.09 MIN	6.31 MPH
------------------------------------	----------	----------

PASS 1-B OVER FIRST SERIES OF TIES	0.10 MIN	5.68 MPH
------------------------------------	----------	----------

REMARKS: No movement of loads or loosening of tiedown straps.

PASS 2-A OVER FIRST SERIES OF TIES	0.10 MIN	5.68 MPH
------------------------------------	----------	----------

PASS 2-B OVER FIRST SERIES OF TIES	0.11 MIN	5.16 MPH
------------------------------------	----------	----------

REMARKS: No movement of loads or loose straps.

30 MILE ROAD TEST: No movement or loose straps.

PANIC STOP TEST: No load movement.

PASS 3-A OVER FIRST SERIES OF TIES	0.10 MIN	5.68 MPH
------------------------------------	----------	----------

PASS 3-B OVER FIRST SERIES OF TIES	0.09 MIN	6.31 MPH
------------------------------------	----------	----------

REMARKS: No change in load position.

PASS 4-A OVER FIRST SERIES OF TIES	0.08 MIN	7.10 MPH
------------------------------------	----------	----------

PASS 4-B OVER FIRST SERIES OF TIES	0.09 MIN	6.31 MPH
------------------------------------	----------	----------

REMARKS: No change in load position.

WASHBOARD COURSE: The MLRS pod loads on the PLS truck flatrack and the trailer flatrack remained intact during this test sequence. No straps loosened.

ROAD TEST DATA

TEST NO. 5

DATE: 11 DEC 91

TEST SPECIMEN: PLS loaded with two MLRS pods (no supports) and the PLS trailer loaded with 37 pallets of 155mm projectiles starting from rear of PLS flatrack.

ROAD HAZARD COURSE.

PASS 1-A OVER FIRST SERIES OF TIES	.11 MIN	5.16 MPH
------------------------------------	---------	----------

PASS 1-B OVER FIRST SERIES OF TIES	.10 MIN	5.68 MPH
------------------------------------	---------	----------

REMARKS: No movement in the 155mm projectile load. No load movement in the two-wide MLRS load.

PASS 2-A OVER FIRST SERIES OF TIES	.09 MIN	6.13 MPH
------------------------------------	---------	----------

PASS 2-B OVER FIRST SERIES OF TIES	.10 MIN	5.68 MPH
------------------------------------	---------	----------

REMARKS: No load movement in either load or loosening of tiedown straps.

30 MILE ROAD TEST: No damage to loads or movement.

PANIC STOP TEST: Some bouncing of the flatrack on the PLS truck. No damage to either load.

PASS 3-A OVER FIRST SERIES OF TIES	.08 MIN	7.10 MPH
------------------------------------	---------	----------

PASS 3-B OVER FIRST SERIES OF TIES	.10 MIN	5.68 MPH
------------------------------------	---------	----------

REMARKS: No movement of loads.

PASS 4-A OVER FIRST SERIES OF TIES	.09 MIN	6.13 MPH
------------------------------------	---------	----------

PASS 4-B OVER FIRST SERIES OF TIES	.10 MIN	5.68 MPH
------------------------------------	---------	----------

REMARKS: No damage to either loads or movement in them.

WASHBOARD COURSE: Flatracks bounce in locking fixtures on the vehicles. No load movement, loose tiedown straps, or load damage.

ROAD TEST DATA

TEST NO. 6

DATE: 12 DEC 91

TEST SPECIMEN: CCL on PLS truck and two MLRS pods on the PLS trailer.

ROAD HAZARD COURSE.

PASS 1-A OVER FIRST SERIES OF TIES	.10 MIN	5.68 MPH
------------------------------------	---------	----------

PASS 1-B OVER FIRST SERIES OF TIES	.11 MIN	5.16 MPH
------------------------------------	---------	----------

REMARKS: No movement in the CCL. Side-to-side movement in the rear of the MLRS pods (approximately 12 inches).

PASS 2-A OVER FIRST SERIES OF TIES	.11 MIN	5.16 MPH
------------------------------------	---------	----------

PASS 2-B OVER FIRST SERIES OF TIES	.10 MIN	5.68 MPH
------------------------------------	---------	----------

REMARKS: No movement of CCL. Load of MLRS pods moving approximately side-to-side 8 inches from original position.

30 MILE ROAD TEST: CCL shifted one inch to the rear. No movement of the two MLRS pods on the PLS trailer.

PANIC STOP TEST: No additional movement of either load.

PASS 3-A OVER FIRST SERIES OF TIES	.10 MIN	5.68 MPH
------------------------------------	---------	----------

PASS 3-B OVER FIRST SERIES OF TIES	.09 MIN	6.31 MPH
------------------------------------	---------	----------

REMARKS: No movement in CCL. MLRS still bounced side-to-side six inches.

PASS 4-A OVER FIRST SERIES OF TIES	.09 MIN	6.31 MPH
------------------------------------	---------	----------

PASS 4-B OVER FIRST SERIES OF TIES	.10 MIN	5.68 MPH
------------------------------------	---------	----------

REMARKS: CCL was okay. MLRS still moves. Straps loosening.

WASHBOARD COURSE: CCL stable. MLRS on trailer shifting side-to-side.

RESULTS: The MLRS load needs to be retested with supports. The CCL could not be removed from the PLS with the load handling system due to overload of the PLS handling system and location of the test load center of gravity. Pallet needs to be reconfigured.

:

ROAD TEST DATA

TEST NO. 7

DATE: 16 DEC 91

TEST SPECIMEN: PLS with one supported MLRS pod and trailer with re-oriented CCL
(155mm pallets at rear of flatrack).

ROAD HAZARD COURSE.

PASS 1-A OVER FIRST SERIES OF TIES	.10 MIN	5.68 MPH
------------------------------------	---------	----------

PASS 1-B OVER FIRST SERIES OF TIES	.09 MIN	6.31 MPH
------------------------------------	---------	----------

REMARKS: No movement in either load.

PASS 2-A OVER FIRST SERIES OF TIES	.09 MIN	6.31 MPH
------------------------------------	---------	----------

PASS 2-B OVER FIRST SERIES OF TIES	.11 MIN	5.13 MPH
------------------------------------	---------	----------

REMARKS: No movement of either load.

30 MILE ROAD TEST: No movement of either load.

PANIC STOP TEST: No load movement.

PASS 3-A OVER FIRST SERIES OF TIES	.10 MIN	5.68 MPH
------------------------------------	---------	----------

PASS 3-B OVER FIRST SERIES OF TIES	.11 MIN	5.13 MPH
------------------------------------	---------	----------

REMARKS: Both loads undamaged and straps tight.

PASS 4-A OVER FIRST SERIES OF TIES	.10 MIN	5.68 MPH
------------------------------------	---------	----------

PASS 4-B OVER FIRST SERIES OF TIES	.09 MIN	6.31 MPH
------------------------------------	---------	----------

REMARKS: No movement of loads. Tiedown straps tight.

WASHBOARD COURSE: No load movement.

ROAD TEST DATA

TEST NO. 8

DATE: 17 DEC 91

TEST SPECIMEN: PLS truck with CCL (artillery pallets at rear of flatrack) and PLS trailer with one supported MLRS pod.

ROAD HAZARD COURSE.

PASS 1-A OVER FIRST SERIES OF TIES .11 MIN 5.16 MPH

PASS 1-B OVER FIRST SERIES OF TIES .10 MIN 5.68 MPH

REMARKS: No movement of either load. Straps tight.

PASS 2-A OVER FIRST SERIES OF TIES .10 MIN 5.68 MPH

PASS 2-B OVER FIRST SERIES OF TIES .09 MIN 6.31 MPH

REMARKS: Straps tight. No load movement.

30 MILE ROAD TEST: CCL shifted one inch to rear of PLS flatrack. Straps tight, both loads.

PANIC STOP TEST: No load movement.

PASS 3-A OVER FIRST SERIES OF TIES .10 MIN 5.68 MPH

PASS 3-B OVER FIRST SERIES OF TIES .11 MIN 5.13 MPH

REMARKS: No load movement.

PASS 4-A OVER FIRST SERIES OF TIES .11 MIN 5.13 MPH

PASS 4-B OVER FIRST SERIES OF TIES .10 MIN 5.68 MPH

REMARKS: No load movement.

WASHBOARD COURSE: Total load movement in CCL and MLRS was less than one inch.

ROAD TEST DATA

TEST NO. 9

DATE: 18 DEC 91

TEST SPECIMEN: PLS truck with three supported MLRS pods on a flatrack. PLS trailer loaded with two supported MLRS pods on a flatrack.

ROAD HAZARD COURSE.

PASS 1-A OVER FIRST SERIES OF TIES	.09 MIN	6.31 MPH
------------------------------------	---------	----------

PASS 1-B OVER FIRST SERIES OF TIES	.11 MIN	5.16 MPH
------------------------------------	---------	----------

REMARKS: No movement in either load.

PASS 2-A OVER FIRST SERIES OF TIES	.10 MIN	5.68 MPH
------------------------------------	---------	----------

PASS 2-B OVER FIRST SERIES OF TIES	.11 MIN	5.16 MPH
------------------------------------	---------	----------

REMARKS: No movement of either load.

30 MILE ROAD TEST: PLS trailer MLRS pod load shifted one inch to the rear of the flatrack.

PANIC STOP TEST: No additional load movement.

PASS 3-A OVER FIRST SERIES OF TIES	.10 MIN	5.68 MPH
------------------------------------	---------	----------

PASS 3-B OVER FIRST SERIES OF TIES	.11 MIN	5.16 MPH
------------------------------------	---------	----------

REMARKS: No movement in either load.

PASS 4-A OVER FIRST SERIES OF TIES	.10 MIN	5.68 MPH
------------------------------------	---------	----------

PASS 4-B OVER FIRST SERIES OF TIES	.09 MIN	6.31 MPH
------------------------------------	---------	----------

REMARKS: No load movement.

WASHBOARD COURSE: No load movement.

ROAD TEST DATA

TEST NO. 10

DATE: 18 DEC 91

TEST SPECIMEN: PLS truck loaded with two supported MLRS pods. PLS trailer loaded with three MLRS pods.

ROAD HAZARD COURSE.

PASS 1-A OVER FIRST SERIES OF TIES	.10 MIN	5.68 MPH
PASS 1-B OVER FIRST SERIES OF TIES	.09 MIN	6.31 MPH

REMARKS: No load movement or loose straps.

PASS 2-A OVER FIRST SERIES OF TIES	.09 MIN	6.31 MPH
PASS 2-B OVER FIRST SERIES OF TIES	.10 MIN	5.68 MPH

REMARKS: Load tight and no apparent damage.

30 MILE ROAD TEST: Loads shifted one inch toward rear of flatrack.

PANIC STOP TEST: No load movement.

PASS 3-A OVER FIRST SERIES OF TIES	.09 MIN	6.31 MPH
PASS 3-B OVER FIRST SERIES OF TIES	.11 MIN	5.16 MPH

REMARKS: No movement in the test loads.

PASS 4-A OVER FIRST SERIES OF TIES	.10 MIN	5.68 MPH
PASS 4-B OVER FIRST SERIES OF TIES	.11 MIN	5.16 MPH

REMARKS: No movement in the test loads.

WASHBOARD COURSE: No movement of the test loads.

PART 5

PHOTOGRAPHS



	U.S. ARMY DEFENSE AMMUNITION CENTER AND SCHOOL - SAVANNA, IL	
--	---	--

EVT-91-02-001	This photo shows one MLRS pod supported on a PLS flatrack. This load was tested separately on the PLS truck/trailer.
----------------------	---



	U.S. ARMY DEFENSE AMMUNITION CENTER AND SCHOOL - SAVANNA, IL	
--	---	--

EVT-91-02-002	This photo shows one MLRS pod supported on a PLS flatrack. This load was tested separately on the PLS truck/trailer.
----------------------	---

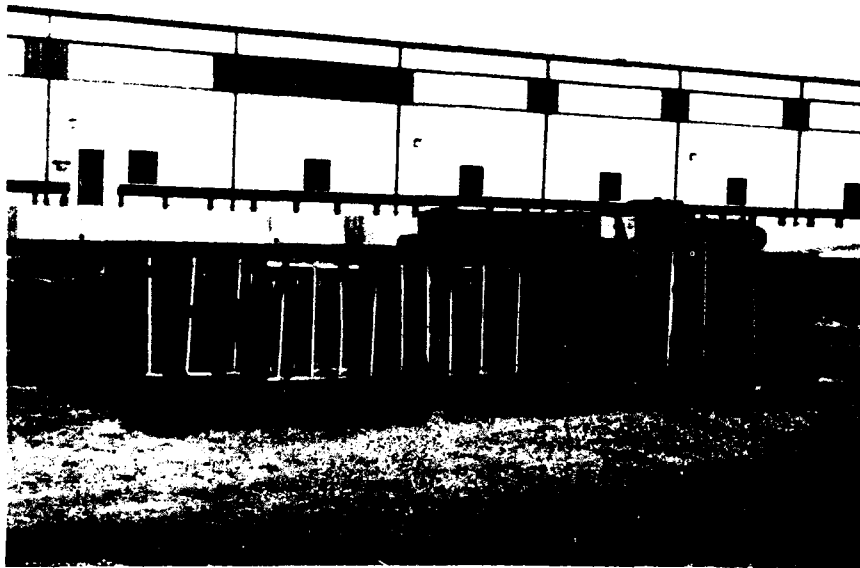

	U.S. ARMY DEFENSE AMMUNITION CENTER AND SCHOOL - SAVANNA, IL	
--	---	--

EVT-91-02-003 This photo shows the CCL on a PLS pallet. It was configured with the heaviest part of the load at the rear of the pallet, to reduce lifting torque on the truck's lifting arm.

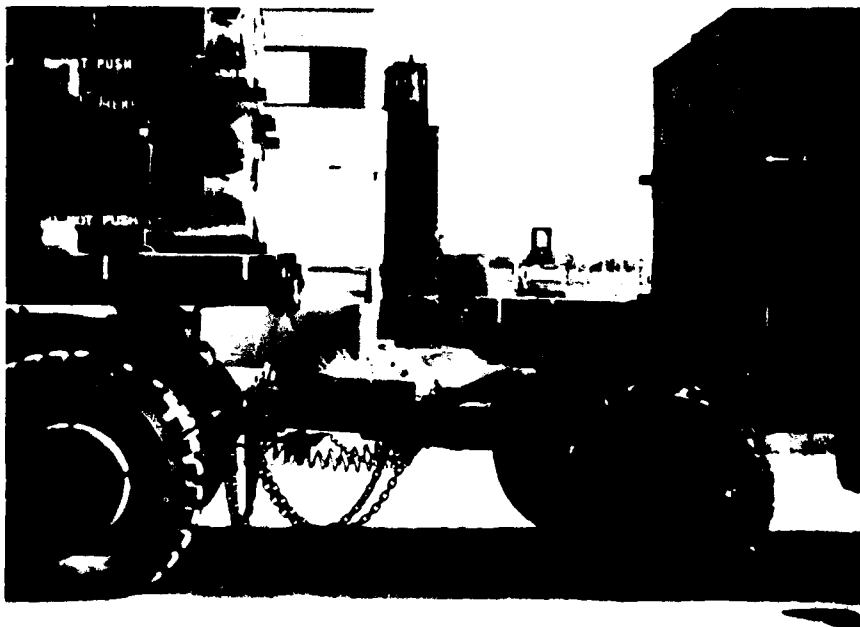

	U.S. ARMY DEFENSE AMMUNITION CENTER AND SCHOOL - SAVANNA, IL	
--	---	--

EVT-91-02-004 This photo shows a closeup of the PLS trailer hitch in a quasi-extended/retracted position. The truck and trailer are loaded with four inert MLRS pods.

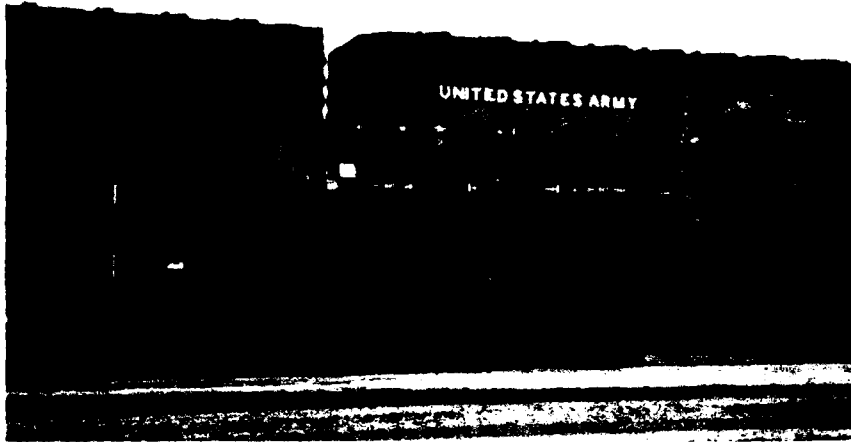

	U.S. ARMY DEFENSE AMMUNITION CENTER AND SCHOOL - SAVANNA, IL	
--	---	--

	EVT-91-02-005 This is a side view of the PLS truck with two MLRS pods loaded side-by-side. This test specimen is unsupported. It passed tests on the PLS truck.
--	--



	U.S. ARMY DEFENSE AMMUNITION CENTER AND SCHOOL - SAVANNA, IL	
--	---	--

	EVT-91-02-006 This photo shows the PLS truck/trailer. The PLS truck is loaded with two inert MLRS pods. The PLS trailer is loaded with 37 pallets of inert 155mm projectiles.
--	--

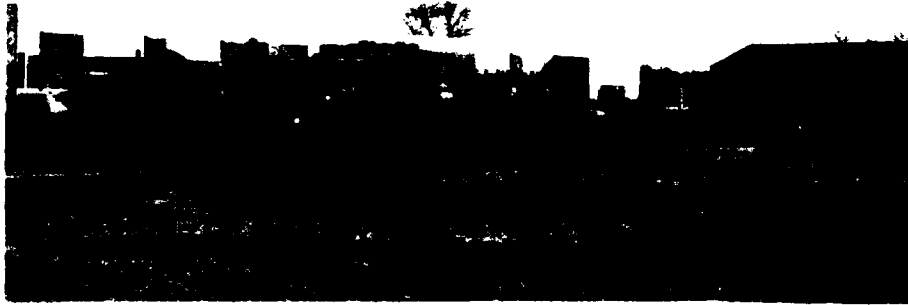

	U.S. ARMY DEFENSE AMMUNITION CENTER AND SCHOOL - SAVANNA, IL	
--	---	--

<p>EVT-91-02-007 This side view of the PLS truck/trailer shows the truck's pallet loaded with a CCL, and the trailer's pallet loaded with two inert MLRS pods. The CCL could not be removed from the PLS truck.</p>
--



	U.S. ARMY DEFENSE AMMUNITION CENTER AND SCHOOL - SAVANNA, IL	
--	---	--

<p>EVT-91-02-008 This side view of the PLS truck/trailer shows a test load on the truck consisting of two supported MLRS pods and a CCL with the 155mm artillery projectiles at the rear of the pallet.</p>
--

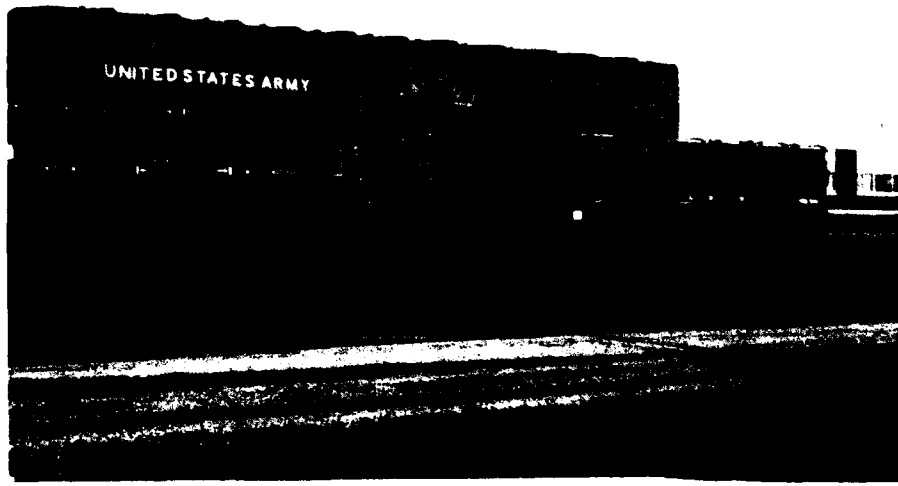

	U.S. ARMY DEFENSE AMMUNITION CENTER AND SCHOOL - SAVANNA, IL	
--	---	--

EVT-91-02-009 This photo shows the PLS trailer and part of the truck. The trailer was loaded with 37 155mm artillery projectiles. The truck was loaded with two unsupported MLRS pods.		
---	--	--



	U.S. ARMY DEFENSE AMMUNITION CENTER AND SCHOOL - SAVANNA, IL	
--	---	--

EVT-91-02-010 This photo shows the PLS truck/trailer. The truck's pallet was loaded with a CCL that was too front heavy for the load handling system to lift. The trailer was loaded with two unsupported MLRS pods.		
---	--	--

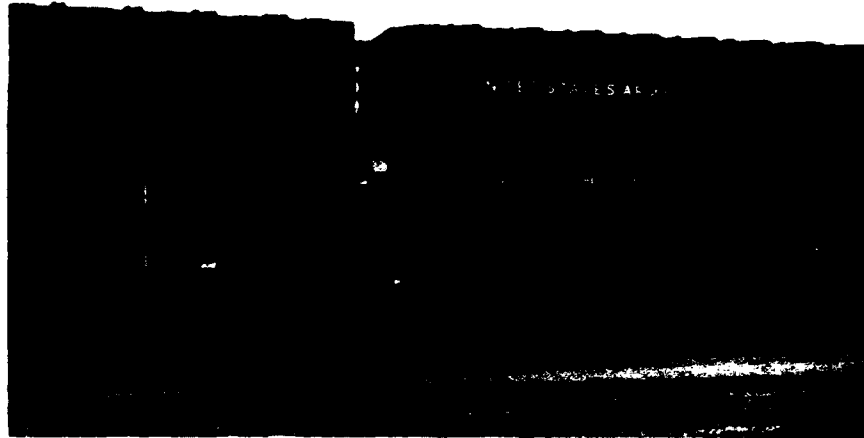

	U.S. ARMY DEFENSE AMMUNITION CENTER AND SCHOOL - SAVANNA, IL	
--	---	--

EVT-91-02-011 This photo shows the PLS truck's pallet loaded with two unsupported MLRS pods. At the right is the trailer loaded with 37 155mm projectiles.		
--	--	--



	U.S. ARMY DEFENSE AMMUNITION CENTER AND SCHOOL - SAVANNA, IL	
--	---	--

EVT-91-02-012 This photo shows the PLS truck/trailer loaded with four supported MLRS pods.		
--	--	--



	U.S. ARMY DEFENSE AMMUNITION CENTER AND SCHOOL - SAVANNA, IL	
--	---	--

EVT-91-02-013 This photo shows test personnel inspecting the four MLRS pods on the trailer after traversing the road hazard course.
--

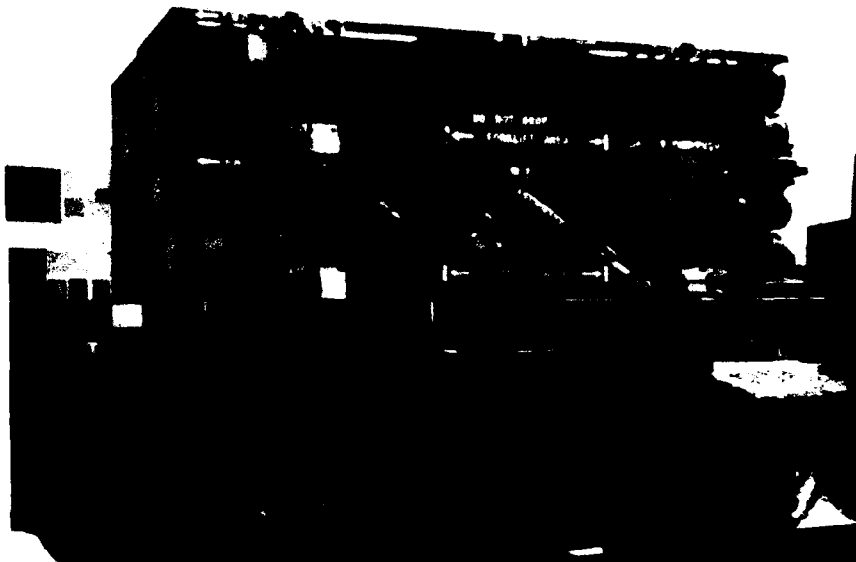

	U.S. ARMY DEFENSE AMMUNITION CENTER AND SCHOOL - SAVANNA, IL	
--	---	--

EVT-91-02-014 This photo shows a test load of four MLRS pods as tested on the PLS truck. Note, load supports between the MLRS pods and flatrack deck and the second layer of pods. This support technique eliminates the need for MLRS skid pockets.

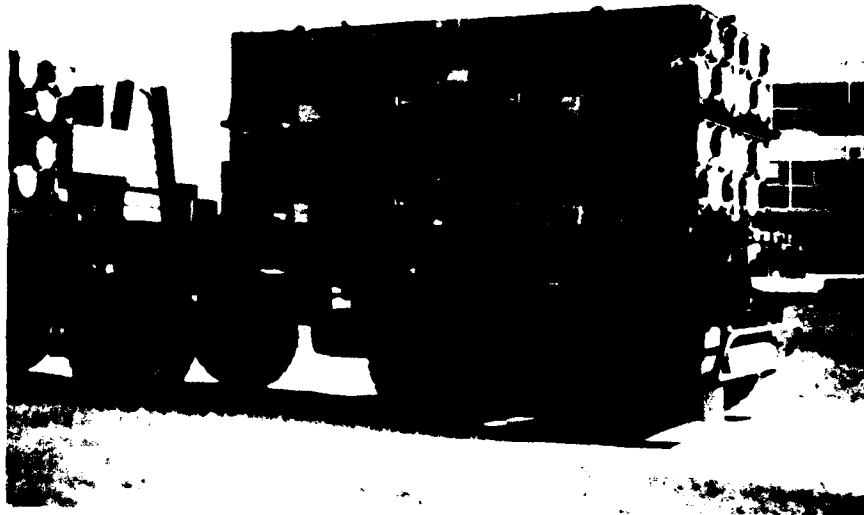

	U.S. ARMY DEFENSE AMMUNITION CENTER AND SCHOOL - SAVANNA, IL	
--	---	--

<p>EVT-91-02-015 This photo shows a test load of four MLRS pods as tested on the PLS trailer. Note, load supports between the MLRS pods and pallet deck and the second layer of pods. This support technique eliminates the need for MLRS skid pockets.</p>
--

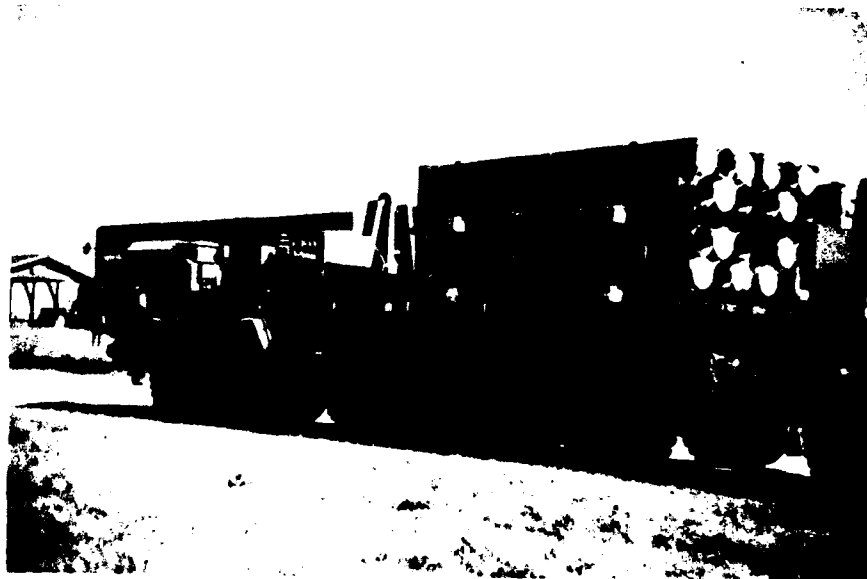

	U.S. ARMY DEFENSE AMMUNITION CENTER AND SCHOOL - SAVANNA, IL	
--	---	--

<p>EVT-91-02-016 This photo shows the PLS truck with a pallet of inertly-filled MLRS pods.</p>

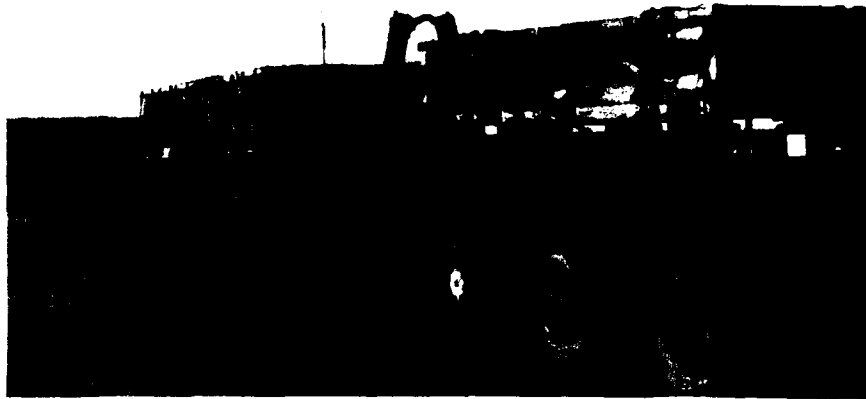

	U.S. ARMY DEFENSE AMMUNITION CENTER AND SCHOOL - SAVANNA, IL	
--	---	--

EVT-91-02-017 This photo shows the rear of the PLS truck/trailer. The truck was loaded with two unsupported MLRS pods. The trailer was loaded with 36 155mm artillery projectiles.



	U.S. ARMY DEFENSE AMMUNITION CENTER AND SCHOOL - SAVANNA, IL	
--	---	--

EVT-91-02-018 This photo shows the flatrack load of MLRS pods moving forward on the trailer after traversing the road hazard course. The flatrack locks were not set when the test was run.
--

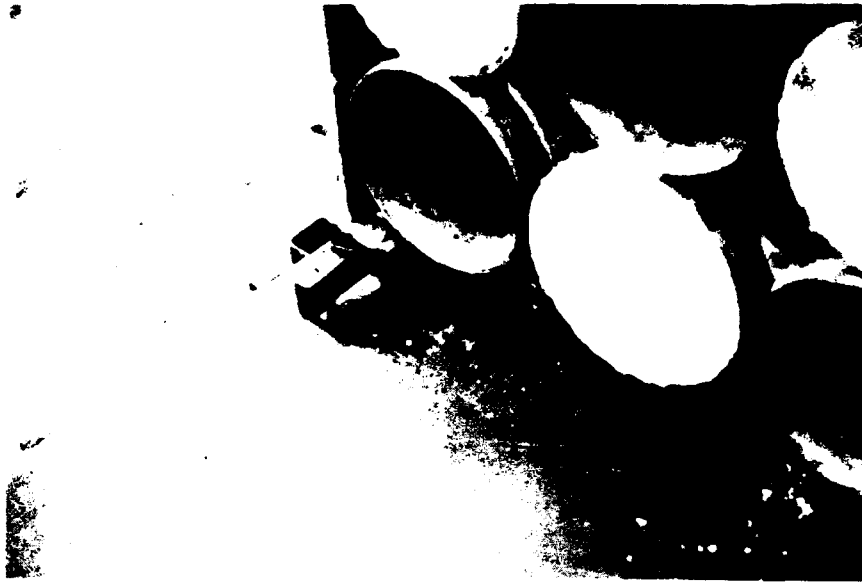

	U.S. ARMY DEFENSE AMMUNITION CENTER AND SCHOOL - SAVANNA, IL	
--	---	--

EVT-91-02-019 The lateral load movement of unsupported MLRS pods was illustrated by the scuff marks in the flatrack deck's paint to the right of the rubber foot.		
---	--	--

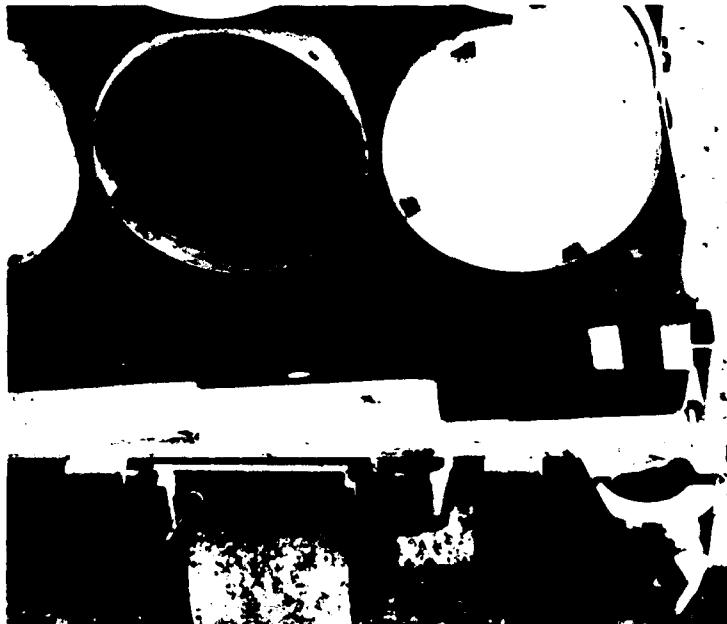

	U.S. ARMY DEFENSE AMMUNITION CENTER AND SCHOOL - SAVANNA, IL	
--	---	--

EVT-91-02-020 Note, lateral scuff marks in the flatrack deck's paint finish to the left of the foot.		
--	--	--

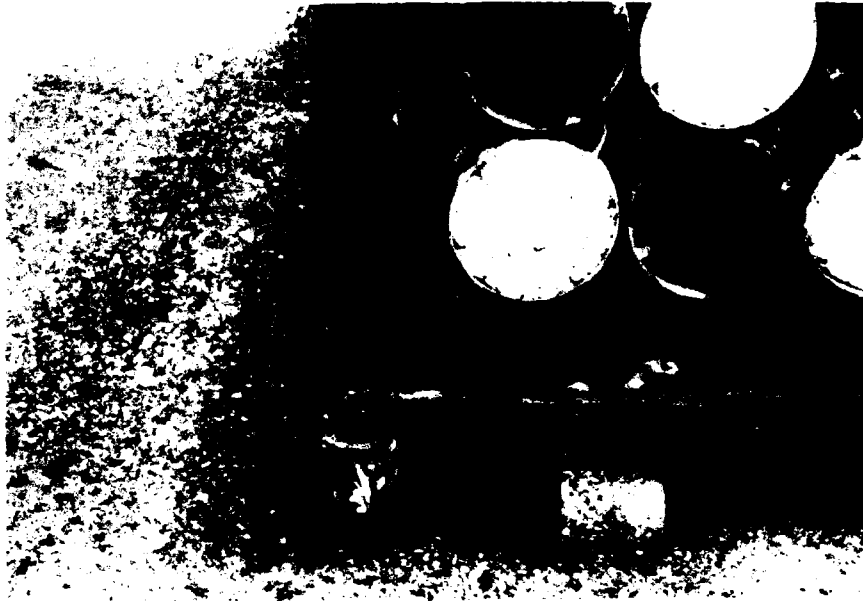

	<p align="center">U.S. ARMY DEFENSE AMMUNITION CENTER AND SCHOOL - SAVANNA, IL</p>	
--	--	--

<p>EVT-91-02-021 Note, the scuff marks in the flatrack deck's paint to the left of the rubber MLRS skid. This test was conducted without support under the MLRS pods. In addition to scuff marks, the flatrack deck was depressed from bouncing pods on the road hazard course.</p>



	<p align="center">U.S. ARMY DEFENSE AMMUNITION CENTER AND SCHOOL - SAVANNA, IL</p>	
--	--	--

<p>EVT-91-02-022 Note, lateral MLRS pod movement on the PLS flatrack. The MLRS was unsupported.</p>



	U.S. ARMY DEFENSE AMMUNITION CENTER AND SCHOOL - SAVANNA, IL	
--	---	--

EVT-91-02-023 This photo shows some of the longitudinal displacement experienced with unsupported MLRS pods after traversing the road hazard course.



	U.S. ARMY DEFENSE AMMUNITION CENTER AND SCHOOL - SAVANNA, IL	
--	---	--

EVT-91-02-024 This photo is a top view of a support assembly after testing. The scuffed paint illustrates approximately 12 inches of longitudinal movement in the support. This was observed only on the road hazard course.

PART 6

DRAWINGS

The test load was prepared using the same blocking and bracing methods specified in the tiedown procedures proposed for use with the munitions. A copy of these procedures is contained in section 3 of this report. The flatrack used in this test shall be inspected to assure its adequacy for munitions transport. Items used to build the load shall be inert (nonexplosive). The weight and physical characteristics of the load configuration shall be identical to the live (explosive) ammunition provided for in the tiedown procedure; i.e., weights, physical dimensions, center of mass, materials, etc. The ammunition packages used shall duplicate that of the live ammunition. Certification of packaging/unitization will have already been accomplished by the U.S. Army Armament Research, Development and Engineering Center (ARDEC), U.S. Army Test and Evaluation Command (TECOM), or USADACS, as appropriate.

LOADING AND TIEDOWN PROCEDURES FOR CONVENTIONAL AMMUNITION ITEMS LOADED ON THE PALLETIZED LOADING SYSTEM (PLS) FLATRACK

INDEX

<u>ITEM</u>	<u>PAGE(S)</u>
GENERAL NOTES, MATERIAL SPECIFICATIONS AND LOADING PROCEDURES - - - - -	2,3
155MM COMBAT CONFIGURED LOAD - - - - -	4,5
25% 155MM COMBAT CONFIGURED LOAD - - - - -	6,7
155MM SEPARATE LOADING PROJECTILES - - - - -	8,9
FOUR MLRS PODS - - - - -	10,11
THREE MLRS PODS - - - - -	12,13
TWO MLRS PODS - - - - -	14,15
ONE MLRS POD - - - - -	16,17
DETAILS - - - - -	18-21

Prepared during December 1991 by:
U.S. Army Defense Ammunition
Center and School
ATTN: SMCAC-DET
Savanna, IL 61074-9639
POC: Mr. John Simons
DSN 585-8074/8927
Comm (815) 273-8074/8927
Fax 585-8811

for Gregory L. Willis
William R. Frerichs
Chief, Transportation Engineering Division

GENERAL NOTES

- A. THE PURPOSE OF THIS DOCUMENT IS TO PROVIDE INTERIM PROCEDURES FOR LOADING AND TIEDOWN OF CONVENTIONAL AMMUNITION ITEMS LOADED ON THE PALLETIZED LOADING SYSTEM (PLS) FLATRACK. ALL LOADS SHOWN WITHIN THIS DOCUMENT MET THE USADACS TEST PARAMETERS AND MAY BE USED TEMPORARILY FOR TYPICAL LOADS DURING TESTING OF THE PALLETIZED LOADING SYSTEM (PLS) FLATRACK.
- B. DEPICTED PROCEDURES APPLY TO FLATRACKS HAVING AN ALL METAL CARGO DECK AREA 19'-0" LONG BY 7'-8-3/4" WIDE, EQUIPPED WITH ELEVEN TIEDOWN ANCHORS ON EACH SIDE AND FOUR ON EACH END. THE EMPTY FLATRACK WEIGHT IS 3,100 POUNDS AND THE LOAD CAPACITY IS 33,000 POUNDS.
- C. WHEN LOADING MAXIMUM WEIGHT, OR NEAR MAXIMUM WEIGHT LOADS, ON THE FLATRACK, SUCH AS SEPARATE LOADING PROJECTILES, START LOADING AS CLOSE TO THE AFT END AS POSSIBLE AND WORK TOWARD THE FORWARD END OF THE FLATRACK. LIGHTER LOADS MAY BE POSITIONED AGAINST THE FORWARD BULKHEAD IF DESIRED. SEE LOADING PROCEDURES ON PAGE 3.
- D. DURING LONG HAULS THE WEB STRAPS SHOULD BE CHECKED AT VEHICLE STOPS AND TIGHTENED IF NECESSARY.
- E. WEB STRAP TIEDOWN ASSEMBLIES MUST BE SECURELY HOOKED INTO ANCHORING DEVICES ON THE TRANSPORTING VEHICLE AND FIRMLY TENSIONED. FIRMLY TENSIONED MEANS, WHEN THE OPERATOR PULLS ON THE RATCHET HANDLE BY HAND, THE RATCHET WILL NOT ADVANCE ANOTHER NOTCH. NO TYPE OF MECHANICAL EXTENSION OR LEVER WILL BE USED. EXERCISE CARE DURING STRAP APPLICATION. AVOID TWISTS IN THE STRAP TO THE EXTENT POSSIBLE (IF TIME PERMITS) BUT ENSURE THERE ARE NO KNOTS IN THE STRAP. ON THE TAKEUP SPOOL OF THE RATCHET, ENSURE STRAIGHT LAY OF THE STRAP WHEN TENSIONING. AFTER INITIAL WEBBING-TO-WEBBING CONTACT HAS BEEN MADE, BY ROTATING THE TAKE-UP SPOOL UNTIL NO METAL ON THE SPOOL IS SHOWING AND THE STRAP HAS MADE CONTACT WITH ITSELF, THE TENSIONED STRAP MUST FORM AT LEAST 1/2 BUT NOT MORE THAN 1-1/2 WRAPS OF STRAP ON THE TAKE-UP SPOOL OF THE TENSIONING RATCHET. AFTER TENSIONING IS COMPLETED, ENSURE THAT THE SPOOL LOCKING-PAWL IS FULLY SEATED AT BOTH ENDS OF THE SPOOL IN MATCHING LOCKING NOTCHES. TIE BACK THE LOOSE END OF THE STRAP AFTER TENSIONING IS COMPLETED (LOOSE END MAY BE FOLDED AND TAPED OR TIED TO THE TENSION STRAP IF TIME PERMITS). FOR ADDITIONAL GUIDANCE, SEE "RATCHET/RATCHETING DETAILS" ON PAGES 20 AND 21.
- F. ADJUSTABLE SCUFF SLEEVES PROVIDED ON WEB STRAP ASSEMBLIES WILL BE LOCATED TO PROVIDE A PAD WHERE STRAPS PASS OVER SHARP EDGES, OR RATCHETS AND HOOKS ON PREVIOUSLY INSTALLED WEB STRAP TIEDOWN ASSEMBLIES.
- G. PROCEDURES DEPICTED HEREIN ARE TYPICAL IN NATURE RELATIVE TO ITEM LOCATION IN/ON THE VEHICLES AND THE QUANTITIES SHOWN. ITEM LOCATION AND QUANTITIES OF THE DESIGNATED ITEM MAY BE VARIED TO SATISFY OPERATIONAL REQUIREMENTS. PROVIDED LOADING AND TIEDOWN PRINCIPLES SPECIFIED HEREIN ARE RETAINED.
- H. WHEN ONE WEB STRAP TIEDOWN ASSEMBLY IS NOT LONG ENOUGH TO SPAN THE DISTANCE DEPICTED, TWO ASSEMBLIES MAY BE HOOKED TOGETHER TO GAIN THE NECESSARY LENGTH.
- J. AFTER ALL LOADING PROCEDURES ARE COMPLETE, CHECK ALL WEB STRAP TIEDOWN ASSEMBLIES FOR MAXIMUM TIGHTNESS AND RATCHET TIGHTER IF REQUIRED. PRIOR TO FOLDING UP AND SECURING THE LOOSE ENDS OF STRAP AS INSTRUCTED IN GENERAL NOTE E.
- K. FOR ADDITIONAL GUIDANCE SEE THE "SPECIAL NOTES" FOR EACH LOAD.

MATERIAL SPECIFICATIONS

STRAP - - - - - : WEBBING, UNIVERSAL TIEDOWN, NSN
5340-00-980-9277, PN10900880, OR NSN
1870-00-725-1437, PN 1378 013.
ALTERNATIVE: NSN 5340-01-089-4997, PN
11669588, OR NSN 5340-01-204-3009, PN
9392419.

LOADING PROCEDURES:

1. WHEN LOADING A FLATRACK ASSURE THAT THE HEAVIEST ITEMS AND/OR THE HEAVIEST PORTION OF THE LOAD IS POSITIONED AS FAR TO THE AFT END OF THE FLATRACK AS POSSIBLE.
2. IF THE WEIGHT OF THE LOAD AT THE FORWARD END OF THE FLATRACK EXCEEDS THE LIFTING CAPABILITY OF THE VEHICLE LIFTING ARM, AN AUTOMATIC LOCKING DEVICE WILL LOCK THE FLATRACK TO THE VEHICLE AND/OR THE TRAILER AND PREVENT THE LIFTING ARM FROM LIFTING THE LOADED FLATRACK AND THEREFORE, THE LOADED FLATRACK CAN NOT BE OFF-LOADED FROM THE VEHICLE AND/OR TRAILER.
3. NOTE THAT A LOADED FLATRACK HAVING A LOAD WEIGHT OF 33,000 POUNDS OR LESS MAY BE HEAVY ENOUGH AT THE FORWARD END TO CAUSE ENGAGEMENT OF THE AUTOMATIC OVERLOAD LOCKING DEVICE ON THE VEHICLE AND/OR TRAILER. THE VEHICLE LIFTING ARM WILL LIFT THIS LOAD ON TO THE VEHICLE AND/OR TRAILER WITH NO INDICATION THAT ONCE LOADED IT MAY ENGAGE THE AUTOMATIC OVERLOAD LOCKING DEVICE WHICH WILL PREVENT THE LOADED FLATRACK FROM BEING UNLOADED FROM THE VEHICLE.
4. PRIOR TO LOADING ITEMS ON THE FLATRACK ASSURE THAT THE DECK IS FREE OF EXCESSIVE AMOUNTS OF DIRT, SAND AND GRAVEL.
5. WHEN ATTACHING A WEB STRAP HOOK TO THE TIEDOWN ANCHOR ON THE FLATRACK ASSURE THAT THE TIEDOWN ANCHOR IS IN A RAISED OR VERTICAL POSITION PRIOR TO AND AFTER THE STRAP IS TIGHTENED.
6. ASSURE THAT ALL PALLET UNITS ARE POSITIONED TIGHTLY AGAINST EACH OTHER Laterally AND LONGITUDINALLY AS LOADING PROGRESSES. THIS WILL REDUCE LOAD MOVEMENT AND THE QUANTITY OF WEB STRAPS REQUIRED TO SECURE THE LOAD. VOID SPACES BETWEEN PALLET UNITS WILL FILL IN DURING TRANSPORT CAUSING WEB STRAPPING TO BECOME LOOSE.
7. EACH LATERAL ROW OF ONE OR MORE PALLET UNITS OF 155MM PROJECTILES MUST BE SECURED WITH TWO WEB STRAPS OVER THE TOP. THESE TWO STRAPS MAY BE CROSSED AND/OR POSITIONED STRAIGHT ACROSS THE TOP OF A ROW. HOWEVER, THEY MUST BE POSITIONED TO THE INSIDE OF LIFTING RING ON THE NOSE END OF THE END PROJECTILES, OF EACH PALLET UNIT ON THE END OF A ROW, AS SHOWN IN THE LOAD ON PAGE 8. THIS WILL ASSURE THAT THERE ARE TWO STRAPS OVER EACH ROW AND THE LIFTING RING WILL ALSO HELP TO KEEP THE STRAP IN POSITION.
8. AFTER ALL LOADING PROCEDURES ARE COMPLETED, CHECK ALL WEB STRAPS FOR MAXIMUM TIGHTNESS AND RATCHET TIGHTER IF REQUIRED, PRIOR TO FOLDING UP AND TAPING THE LOOSE ENDS OF STRAP AS INSTRUCTED IN GENERAL NOTE "E" ON PAGE 2.
9. DURING LONG HAULS, WHEN POSSIBLE, STRAPS SHOULD BE CHECKED DURING VEHICLE STOPS AND TIGHTENED, IF NECESSARY.

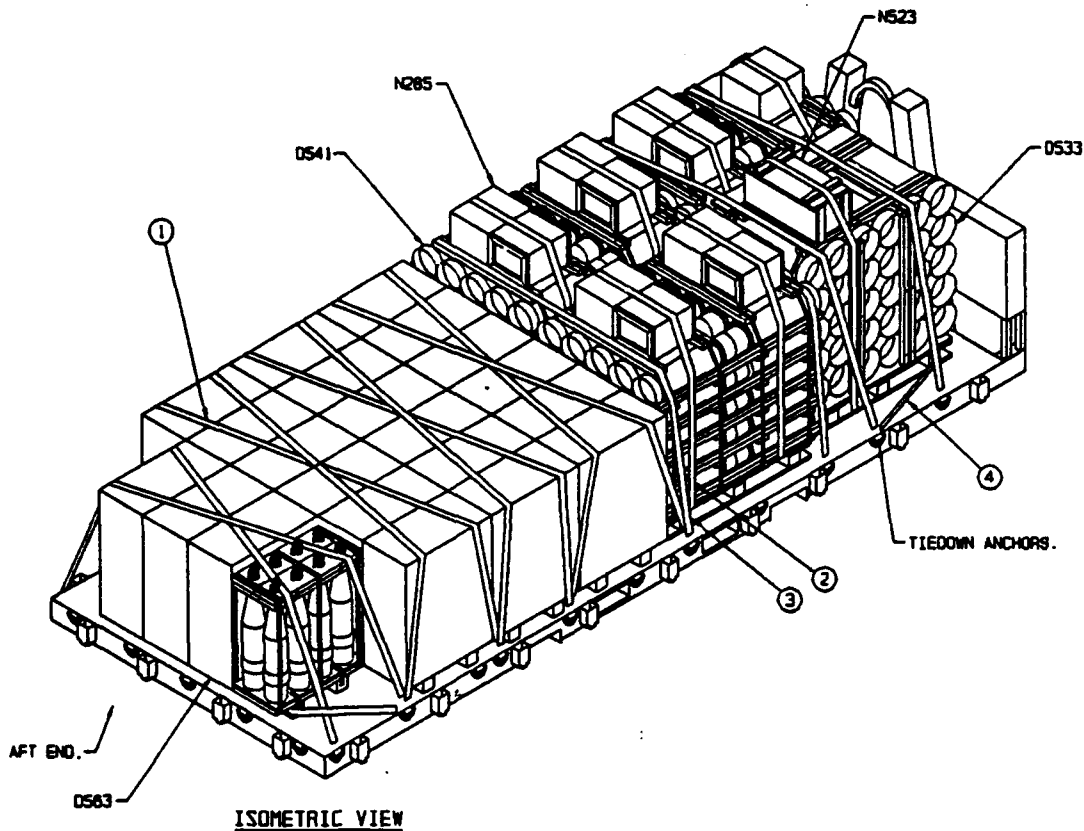

ISOMETRIC VIEW

KEY NUMBERS

- ① WEB STRAP TIEDOWN ASSEMBLY (8 REQD). INSTALL EACH STRAP FROM A TIEDOWN ANCHOR, ON SIDE OF FLATRACK, OVER TOP OF A ROW OF PALLET UNITS, TO A TIEDOWN ANCHOR ON OPPOSITE SIDE OF FLATRACK. POSITION STRAP SCUFF PADS AT SHARP EDGES. TAKE UP EXCESS SLACK IN STRAP AND THEN RATCHET TIGHT.
- ② WEB STRAP TIEDOWN ASSEMBLY (7 REQD). PRE-POSITION EACH STRAP UNDER TOP DECK OF PALLET AT LOCATION DESIRED. PRIOR TO POSITIONING PALLET UNITS TIGHT AGAINST EACH OTHER. POSITION LOOSE BOXES ON TOP OF THE PALLET UNITS. BRING ENDS OF STRAP UP OVER TOP OF LOOSE BOXES AND HOOK ENDS OF STRAP TOGETHER. POSITION STRAP SCUFF PADS AT SHARP EDGES. TAKE UP EXCESS SLACK IN STRAP AND THEN RATCHET.
- ③ WEB STRAP TIEDOWN ASSEMBLY (4 REQD). INSTALL EACH STRAP FROM A TIEDOWN ANCHOR, ON SIDE OF FLATRACK, OVER TOP OF EACH TWO LATERALLY ADJACENT PALLET UNITS TO A TIEDOWN ANCHOR ON OPPOSITE SIDE OF FLATRACK. POSITION STRAP SCUFF PADS AT SHARP EDGES. TAKE UP EXCESS SLACK IN STRAP AND THEN RATCHET TIGHT.
- ④ WEB STRAP TIEDOWN ASSEMBLY (2 REQD). INSTALL EACH STRAP FROM A TIEDOWN ANCHOR, ON SIDE OF FLATRACK, AROUND PALLET BASE AS SHOWN AT EACH END OF LOAD, TO A TIEDOWN ANCHOR ON OPPOSITE SIDE OF FLATRACK. POSITION STRAP SCUFF PADS AT SHARP EDGES. TAKE UP EXCESS SLACK IN STRAP AND THEN RATCHET TIGHT.

COMBAT CONFIGURED LOAD				
DDIC	ITEM	ITEM QUANTITY	LOAD QUANTITY	TOTAL WEIGHT
D533	PROP CHG, 155MM, W8 M199 45.50 L X 35.75 V X 49.00 H	30	1 PALLET	1,562
D541	PROP CHG, 155MM, W8 M4 55.00 L X 40.00 V X 44.88 H	150	3 PALLETS	5,298
D563	PROJ, 155MM, ICH, M483A1 14.62 L X 29.12 V X 39.38 H	176	22 PALLETS	19,228
N285	FUZE, M160, M577 14.63 L X 12.75 V X 9.18 H	176	11 BOXES	600
N523	PERCUSSION PRIMER, M82 24.13 L X 12.00 V X 11.25 H	500	1 BOX	62

SPECIAL NOTES:

1. WHEN LOADING FLATRACK POSITION THE FOUR PALLET UNITS OF PROPELLING CHARGE CONTAINERS AT THE FORWARD END AS SHOWN, WITH THE REAR TWO PALLETS IN LINE Laterally TO PROVIDE AN EVEN SURFACE FOR THE SLP PALLETS. THEN POSITION THREE ROWS OF SIX EACH, 155MM SLP PALLET UNITS, AGAINST THE PALLET UNITS OF PROPELLING CHARGE CONTAINERS. SEE LOADING PROCEDURES ON PAGE 3.
2. PRIOR TO LOADING PALLET UNITS ASSURE THAT ALL STEEL STRAPPING ON EACH PALLET UNIT IS IN POSITION AND IS TIGHT. MISSING AND LOOSE STEEL STRAPPING SHOULD BE REPLACED.
3. EACH LATERAL ROW OF ONE OR MORE PALLET UNITS MUST BE SECURED WITH TWO WEB STRAPS OVER THE TOP AS SHOWN. THESE TWO STRAPS MAY BE CROSSED AND/OR POSITIONED STRAIGHT ACROSS THE TOP OF A ROW.
4. ALL PALLET UNITS MUST BE POSITIONED TIGHTLY AGAINST EACH OTHER Laterally AND LONGITUDINALLY. THIS WILL REDUCE LOAD MOVEMENT AND THE QUANTITY OF WEB STRAPS REQUIRED TO SECURE THE LOAD. VOID SPACES BETWEEN PALLET UNITS WILL FILL IN DURING TRANSPORT CAUSING WEB STRAPPING TO BECOME LOOSE.
5. A TOTAL OF TWENTY-ONE WEB STRAP TIEDOWN ASSEMBLIES ARE REQUIRED FOR THE LOAD SHOWN.

LOAD AS SHOWN

<u>ITEM</u>	<u>WEIGHT (APPROX)</u>
155MM COMBAT CONFIGURED LOAD - - - -	26.750 LBS

155MM COMBAT CONFIGURED LOAD

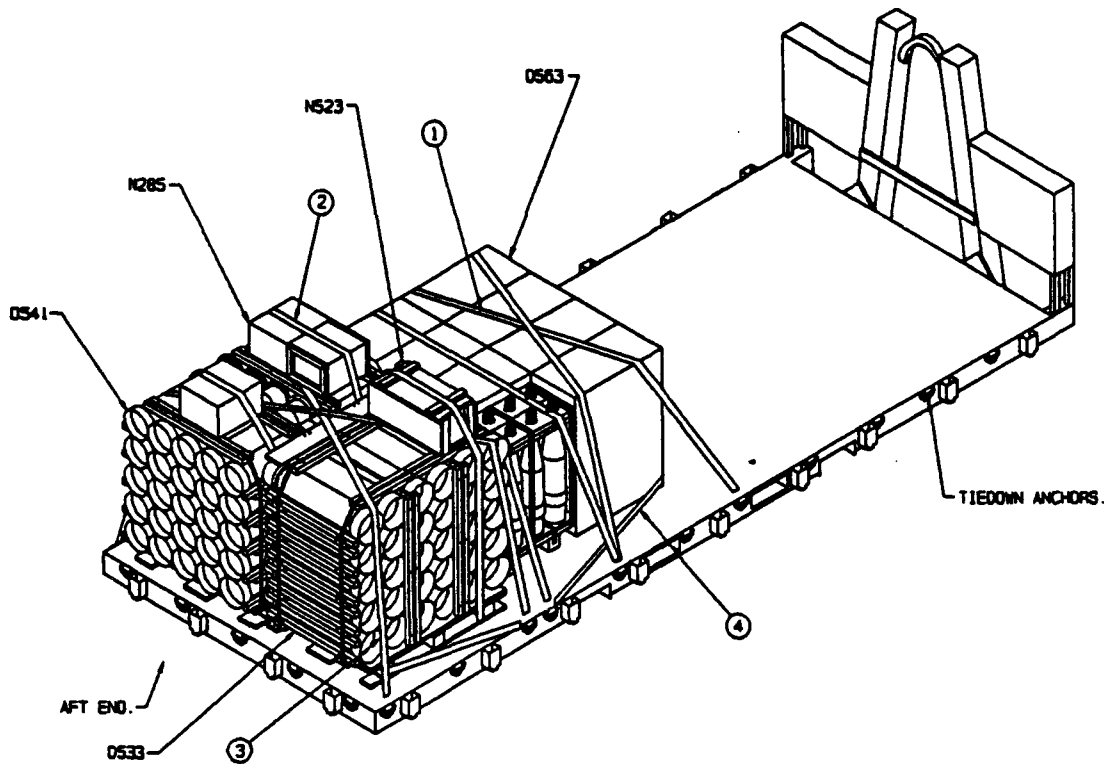

ISOMETRIC VIEW

KEY NUMBERS

- ① WEB STRAP TIEDOWN ASSEMBLY (4 REQD). INSTALL EACH STRAP FROM A TIEDOWN ANCHOR, ON SIDE OF FLATRACK, OVER TOP OF A ROW OF PALLET UNITS, TO A TIEDOWN ANCHOR ON OPPOSITE SIDE OF FLATRACK. POSITION STRAP SCUFF PADS AT SHARP EDGES. TAKE UP EXCESS SLACK IN STRAP AND THEN RATCHET TIGHT.
- ② WEB STRAP TIEDOWN ASSEMBLY (3 REQD). PRE-POSITION EACH STRAP UNDER TOP DECK OF PALLET AT LOCATION DESIRED. PRIOR TO POSITIONING PALLET UNITS TIGHT AGAINST EACH OTHER. POSITION LOOSE BOXES ON TOP OF THE PALLET UNITS. BRING ENDS OF STRAP UP OVER TOP OF LOOSE BOXES AND HOOK ENDS OF STRAP TOGETHER. POSITION STRAP SCUFF PADS AT SHARP EDGES. TAKE UP EXCESS SLACK IN STRAP AND THEN RATCHET.
- ③ WEB STRAP TIEDOWN ASSEMBLY (2 REQD). INSTALL EACH STRAP FROM A TIEDOWN ANCHOR, ON SIDE OF FLATRACK, OVER TOP OF EACH TWO LATERALLY ADJACENT PALLET UNITS TO A TIEDOWN ANCHOR ON OPPOSITE SIDE OF FLATRACK. POSITION STRAP SCUFF PADS AT SHARP EDGES. TAKE UP EXCESS SLACK IN STRAP AND THEN RATCHET TIGHT.
- ④ WEB STRAP TIEDOWN ASSEMBLY (2 REQD). INSTALL EACH STRAP FROM A TIEDOWN ANCHOR, ON SIDE OF FLATRACK, AROUND PALLET BASE AS SHOWN AT EACH END OF LOAD, TO A TIEDOWN ANCHOR ON OPPOSITE SIDE OF FLATRACK. POSITION STRAP SCUFF PADS AT SHARP EDGES. TAKE UP EXCESS SLACK IN STRAP AND THEN RATCHET TIGHT.

COMBAT CONFIGURED LOAD

DDIC	ITEM	ITEM QUANTITY	LOAD QUANTITY	TOTAL WEIGHT
0533	PROP CHG, 155MM, WB M198 45.50 L X 35.75 W X 48.00 H	30	1 PALLET	1,562
0541	PROP CHG, 155MM, WB M4 55.00 L X 40.00 W X 44.88 H	50	1 PALLET	1,766
0563	PROJ, 155MM, ICM, M483A1 14.82 L X 29.12 W X 39.38 H	84	8 PALLETS	8,992
N285	FUZE, MT90, M577 14.83 L X 12.75 W X 9.18 H	48	3 BOXES	184
NS23	PERCUSSION PRIMER, M82 24.13 L X 12.00 W X 11.25 H	500	1 BOX	62

SPECIAL NOTES:

1. WHEN LOADING FLATRACK POSITION THE TWO PALLET UNITS OF PROPELLING CHARGE CONTAINERS AT THE AFT END WITH THE FOREMOST ENDS OF THE PALLET UNITS IN LINE Laterally TO PROVIDE AN EVEN SURFACE FOR THE SLP PALLETS. THEN POSITION TWO ROWS OF FOUR EACH, 155MM SLP PALLET UNITS, AGAINST THE PALLET UNITS OF PROPELLING CHARGE CONTAINERS. THE LOAD MAY BE POSITIONED ANYWHERE WITHIN THE LENGTH OF THE FLATRACK. HOWEVER, THE AFT END OF THE FLATRACK IS THE ROUGHEST RIDING AREA. SEE LOADING PROCEDURES ON PAGE 3.
2. PRIOR TO LOADING PALLET UNITS ASSURE THAT ALL STEEL STRAPPING ON EACH PALLET UNIT IS IN POSITION AND IS TIGHT. MISSING AND LOOSE STEEL STRAPPING SHOULD BE REPLACED.
3. EACH LATERAL ROW OF ONE OR MORE PALLET UNITS MUST BE SECURED WITH TWO WEB STRAPS OVER THE TOP AS SHOWN. THESE TWO STRAPS MAY BE CROSSED AND/OR POSITIONED STRAIGHT ACROSS THE TOP OF A ROW.
4. ALL PALLET UNITS MUST BE POSITIONED TIGHTLY AGAINST EACH OTHER Laterally AND LONGITUDINALLY. THIS WILL REDUCE LOAD MOVEMENT AND THE QUANTITY OF WEB STRAPS REQUIRED TO SECURE THE LOAD. VOID SPACES BETWEEN PALLET UNITS WILL FILL IN DURING TRANSPORT CAUSING WEB STRAPPING TO BECOME LOOSE.
5. A TOTAL OF ELEVEN WEB STRAP TIEDOWN ASSEMBLIES ARE REQUIRED FOR THE LOAD SHOWN.

LOAD AS SHOWN

<u>ITEM</u>	<u>WEIGHT (APPROX)</u>
COMBAT CONFIGURED LOAD - - - - -	10,546 LBS

25% COMBAT CONFIGURED LOAD

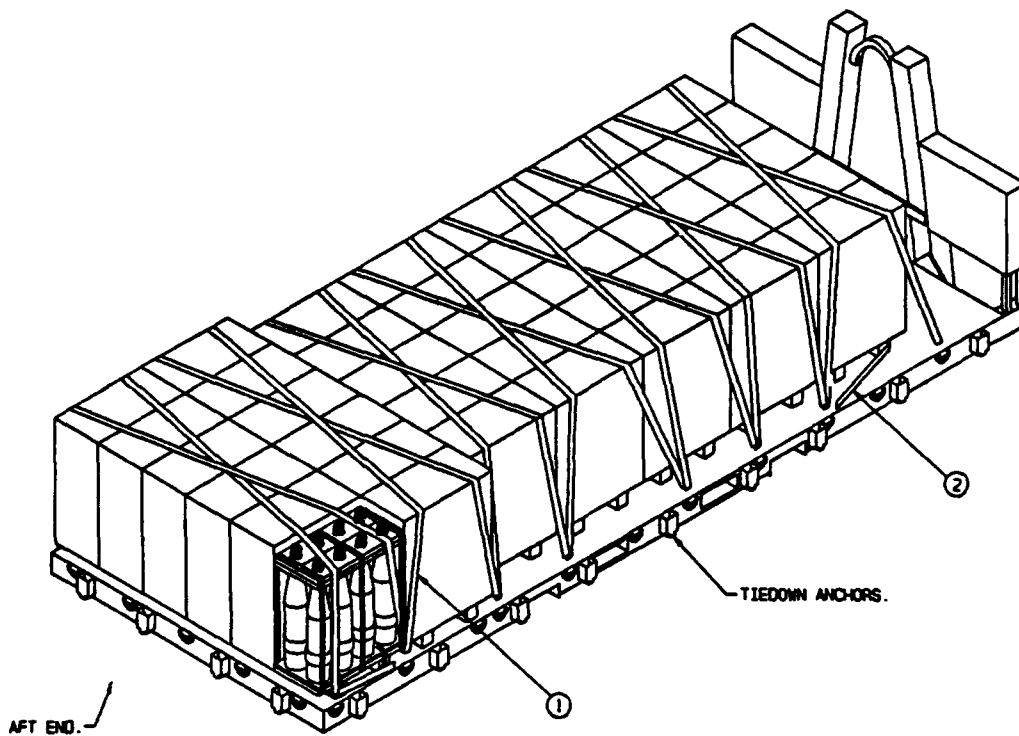

ISOMETRIC VIEW

KEY NUMBERS

- ① WEB STRAP TIEDOWN ASSEMBLY (14 REQD). INSTALL EACH STRAP FROM A TIEDOWN ANCHOR, ON SIDE OF FLATRACK, OVER TOP OF A ROW OF PALLET UNITS, TO A TIEDOWN ANCHOR ON OPPOSITE SIDE OF FLATRACK. POSITION STRAP SCUFF PADS AT SHARP EDGES. TAKE UP EXCESS SLACK IN STRAP AND THEN RATCHET TIGHT.
- ② WEB STRAP TIEDOWN ASSEMBLY (2 REQD). INSTALL EACH STRAP FROM A TIEDOWN ANCHOR, ON SIDE OF FLATRACK, AROUND PALLET BASE AS SHOWN AT EACH END OF LOAD, TO A TIEDOWN ANCHOR ON OPPOSITE SIDE OF FLATRACK. POSITION STRAP SCUFF PADS AT SHARP EDGES. TAKE UP EXCESS SLACK IN STRAP AND THEN RATCHET TIGHT.

COMBAT CONFIGURED LOAD				
OODIC	ITEM	ITEM QUANTITY	LOAD QUANTITY	TOTAL WEIGHT
0563	PROJ, 155MM, ICM, M483A1 14.62 L X 29.12 W X 39.38 H	296	37 PALLETS	32,336

SPECIAL NOTES:

1. WHEN LOADING FLATRACK POSITION A ROW OF SIX PALLET UNITS ACROSS THE WIDTH OF FLATRACK AND EVEN WITH THE AFT END OF THE DECK. THEN POSITION A SECOND ROW OF SIX PALLET UNITS TIGHT AGAINST THE FIRST ROW. POSITION FIVE ROWS OF FIVE PALLET UNITS EACH TIGHT AGAINST EACH OTHER AND THE SECOND ROW OF SIX PALLET UNITS. SEE LOADING PROCEDURES ON PAGE 3.
2. PRIOR TO LOADING PALLET UNITS ASSURE THAT ALL STEEL STRAPPING ON EACH PALLET UNIT IS IN POSITION AND IS TIGHT. MISSING AND/OR LOOSE STEEL STRAPPING SHOULD BE REPLACED.
3. EACH LATERAL ROW OF ONE OR MORE PALLET UNITS MUST BE SECURED WITH TWO WEB STRAPS OVER THE TOP AS SHOWN. THESE TWO STRAPS MAY BE CROSSED AND/OR POSITIONED STRAIGHT ACROSS THE TOP OF A ROW. HOWEVER, THEY MUST BE POSITIONED TO THE INSIDE OF LIFTING RING ON THE NOSE END OF THE END PROJECTILES, OF EACH PALLET UNIT ON THE END OF A ROW, AS SHOWN IN THE LOAD ON PAGE 8. THIS WILL ASSURE THAT THERE ARE TWO STRAPS OVER EACH ROW AND THE LIFTING RING WILL ALSO HELP TO KEEP THE STRAP IN POSITION.
4. ALL PALLET UNITS MUST BE POSITIONED TIGHTLY AGAINST EACH OTHER Laterally AND LONGITUDINALLY. THIS WILL REDUCE LOAD MOVEMENT AND THE QUANTITY OF WEB STRAPS REQUIRED TO SECURE THE LOAD. VOID SPACES BETWEEN PALLET UNITS WILL FILL IN DURING TRANSPORT CAUSING WEB STRAPPING TO BECOME LOOSE.
5. A TOTAL OF SIXTEEN WEB STRAP TIEDOWN ASSEMBLIES ARE REQUIRED FOR THE LOAD SHOWN.

LOAD AS SHOWN

<u>ITEM</u>	<u>WEIGHT (APPROX)</u>
155MM PALLET - - - - - 37 - - - - -	32,338 LBS

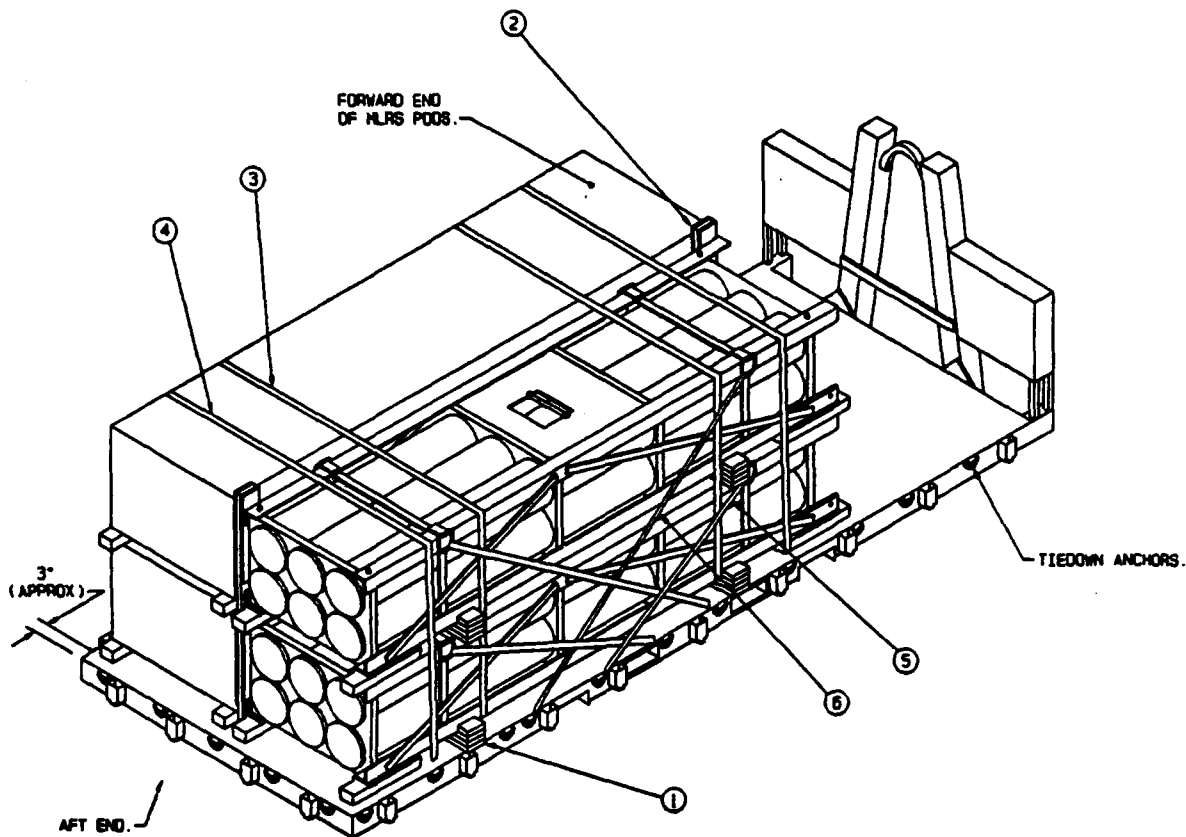

ISOMETRIC VIEW

KEY NUMBERS

- ① SUPPORT ASSEMBLY A (4 REQD). SEE THE DETAIL ON PAGE 19. POSITION AT LOCATIONS SHOWN, WITH SECOND LAYER SUPPORT ASSEMBLY ADJACENT TO THE LIFT/TIEDOWN RING ON THE BOTTOM PODS AND IN LINE VERTICALLY. SEE SPECIAL NOTES 1 AND 2 ON PAGE 11.
- ② SPACER ASSEMBLY A (2 REQD). SEE DETAIL ON PAGE 19. POSITION ONE ASSEMBLY AS NEAR TO EACH END OF LOAD AS POSSIBLE AND WIRE TIE IN PLACE AT TOP AND BOTTOM OF ASSEMBLY. SEE SPECIAL NOTES 1 AND 3 ON PAGE 11.
- ③ WEB STRAP TIEDOWN ASSEMBLY (2 REQD). EACH ASSEMBLY WILL CONSIST OF TWO WEB STRAPS HOOKED TOGETHER TO ENCIRCLE ALL FOUR MLRS PODS AT THE LOCATION SHOWN, ADJACENT TO SUPPORT ASSEMBLIES. POSITION STRAP SCUFF PADS AT SHARP EDGES. TAKE UP EXCESS SLACK IN STRAP AND THEN RATCHET TIGHT. NOTE: ASSURE THAT THE SUPPORT ASSEMBLY A AND SPACER ASSEMBLY A PIECES ARE IN POSITION PRIOR TO RATCHETING STRAPS TIGHT.
- ④ WEB STRAP TIEDOWN ASSEMBLY (2 REQD). INSTALL EACH STRAP FROM A TIEDOWN ANCHOR, ON SIDE OF FLATRACK, OVER TOP OF LOAD, TO A TIEDOWN ANCHOR ON OPPOSITE SIDE OF FLATRACK. POSITION STRAP SCUFF PADS AT SHARP EDGES. TAKE UP EXCESS SLACK IN STRAP AND THEN RATCHET TIGHT.
- ⑤ WEB STRAP TIEDOWN ASSEMBLY (4 REQD). INSTALL EACH STRAP FROM A TIEDOWN ANCHOR, ON SIDE OF FLATRACK, TO A LIFT/TIEDOWN RING ON THE FAR END OF THE BOTTOM MLRS POD AS SHOWN. TAKE UP EXCESS SLACK IN STRAP AND THEN RATCHET TIGHT.
- ⑥ WEB STRAP TIEDOWN ASSEMBLY (4 REQD). INSTALL EACH STRAP FROM A TIEDOWN ANCHOR, ON SIDE OF FLATRACK, TO A LIFT/TIEDOWN RING ON THE FAR END OF THE TOP MLRS POD AS SHOWN. TAKE UP EXCESS SLACK IN STRAP AND THEN RATCHET TIGHT.

COMBAT CONFIGURED LOAD				
DDIC	ITEM	ITEM QUANTITY	LOAD QUANTITY	TOTAL WEIGHT
H104	MLRS POD 166.0 L X 41.5 W X 33.0 H	24	4 PODS	20,312

SPECIAL NOTES:

1. POSITION FOUR MLRS PODS AT AFT END OF FLATRACK AT LOCATION SHOWN. WITH THE FORWARD END OF THE PODS TOWARD THE FORE END OF THE FLATRACK. POSITION THE SUPPORT ASSEMBLY A AND SPACER ASSEMBLY A PIECES AS LOADING PROGRESSES. NOTE: ASSURE THAT THE STACKING PINS ON THE BOTTOM PODS ARE MATED TO THE HOLES IN THE SKIDS OF THE TOP PODS.
2. THE SUPPORT ASSEMBLY A PIECES ARE REQUIRED TO PREVENT THE SKIDS FROM DEFORMING AND TO PROVIDE STABILITY FOR THE STACKED PODS DURING TRANSPORT.
3. THE SPACER ASSEMBLY A PIECES ARE REQUIRED SO THE MLRS PODS CAN BE POSITIONED IN LINE WITH EACH OTHER Laterally WITHOUT THE LIFT/TIEDOWN RINGS ON ADJACENT PODS CONTACTING EACH OTHER. PRIOR TO PICKING UP PODS WITH LAUNCHER, CUT WIRE TIES AND KNOCK SPACER ASSEMBLIES OUT FROM BETWEEN PODS.
4. A TOTAL OF FOURTEEN WEB STRAP TIEDOWN ASSEMBLIES ARE REQUIRED FOR THE LOAD SHOWN.

LOAD AS SHOWN

<u>ITEM</u>	<u>WEIGHT (APPROX)</u>
COMBAT CONFIGURED LOAD -----	20,312 LBS
DUNNAGE -----	241 LBS
TOTAL WEIGHT -----	20,553 LBS

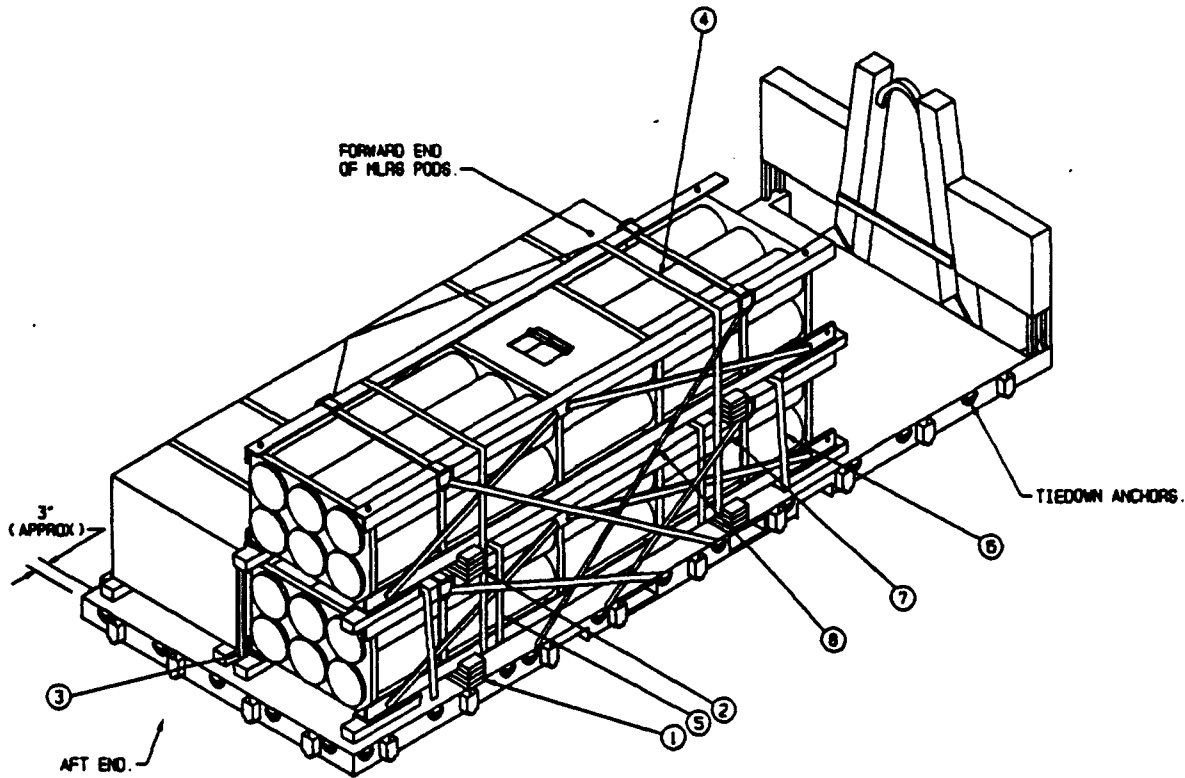

ISOMETRIC VIEW

KEY NUMBERS

- ① SUPPORT ASSEMBLY A (4 REQD). SEE THE DETAIL ON PAGE 19. POSITION AT LOCATIONS SHOWN. SEE SPECIAL NOTES 1 AND 2 ON PAGE 11.
- ② SUPPORT ASSEMBLY B (4 REQD). SEE THE DETAIL ON PAGE 19. POSITION AT LOCATIONS SHOWN. SEE SPECIAL NOTES 1 AND 2 ON PAGE 11.
- ③ SPACER ASSEMBLY B (2 REQD). SEE DETAIL ON PAGE 19. POSITION ONE ASSEMBLY AS NEAR TO EACH END OF LOAD AS POSSIBLE AND WIRE TIE IN PLACE AT TOP AND BOTTOM OF ASSEMBLY. SEE SPECIAL NOTES 1 AND 3 ON PAGE 11.
- ④ WEB STRAP TIEDOWN ASSEMBLY (2 REQD). INSTALL EACH STRAP TO ENCIRCLE TOP AND BOTTOM MLRS PODS AT THE LOCATIONS SHOWN. POSITION STRAP SCUFF PADS AT SHARP EDGES. TAKE UP EXCESS SLACK IN STRAP AND THEN RATCHET TIGHT. NOTE: ASSURE THAT THE SUPPORT ASSEMBLIES A AND B ARE IN POSITION PRIOR TO RATCHETING STRAPS MARKED ④ TIGHT.
- ⑤ WEB STRAP TIEDOWN ASSEMBLY (2 REQD). INSTALL EACH STRAP TO ENCIRCLE BOTTOM TWO LATERALLY ADJACENT MLRS PODS AT LOCATIONS SHOWN. POSITION STRAP SCUFF PADS AT SHARP EDGES. TAKE UP EXCESS SLACK IN STRAP AND THEN RATCHET TIGHT. NOTE: ASSURE THAT SUPPORT ASSEMBLY A PIECES AND SPACER ASSEMBLY B PIECES ARE IN POSITION PRIOR TO RATCHETING STRAPS MARKED ⑤ TIGHT.
- ⑥ WEB STRAP TIEDOWN ASSEMBLY (2 REQD). INSTALL EACH STRAP FROM A TIEDOWN ANCHOR, ON SIDE OF FLATRACK, OVER TOP OF BOTH BOTTOM MLRS PODS, TO A TIEDOWN ANCHOR ON OPPOSITE SIDE OF FLATRACK. POSITION STRAP SCUFF PADS AT SHARP EDGES. TAKE UP EXCESS SLACK IN STRAP AND THEN RATCHET TIGHT.
- ⑦ WEB STRAP TIEDOWN ASSEMBLY (4 REQD). INSTALL EACH STRAP FROM A TIEDOWN ANCHOR, ON SIDE OF FLATRACK, TO A LIFT/TIEDOWN RING ON THE FAR END OF THE BOTTOM MLRS POD AS SHOWN. TAKE UP EXCESS SLACK IN STRAP AND THEN RATCHET TIGHT.
- ⑧ WEB STRAP TIEDOWN ASSEMBLY (4 REQD). INSTALL EACH STRAP FROM A TIEDOWN ANCHOR, ON SIDE OF FLATRACK, TO A LIFT/TIEDOWN RING ON THE FAR END OF THE TOP MLRS POD AS SHOWN. TAKE UP EXCESS SLACK IN STRAP AND THEN RATCHET TIGHT.

COMBAT CONFIGURED LOAD				
DDIC	ITEM	ITEM QUANTITY	LOAD QUANTITY	TOTAL WEIGHT
W104	MLRS POD 166.0 L X 41.5 W X 33.0 H	18	3 PODS	15,234

SPECIAL NOTES:

1. POSITION THREE MLRS PODS AT AFT END OF FLATRACK AT LOCATION SHOWN. WITH THE FORWARD END OF THE PODS TOWARD THE FORWARD END OF THE FLATRACK. POSITION THE SUPPORT ASSEMBLIES A AND B. AND SPACER ASSEMBLY B PIECES AS LOADING PROGRESSES. NOTE: ASSURE THAT THE STACKING PINS ON THE BOTTOM POD ARE MATED TO THE HOLES IN THE SKIDS OF THE TOP POD.
2. THE SUPPORT ASSEMBLIES A AND B REQUIRED TO PREVENT THE SKIDS FROM DEFORMING AND TO PROVIDE STABILITY FOR THE STACKED PODS DURING TRANSPORT.
3. THE SPACER ASSEMBLY A PIECES ARE REQUIRED SO THE MLRS PODS CAN BE POSITIONED IN LINE WITH EACH OTHER LATERALLY WITHOUT THE LIFT/TIEDOWN RINGS ON ADJACENT PODS CONTACTING EACH OTHER.
4. A TOTAL OF FOURTEEN WEB STRAP TIEDOWN ASSEMBLIES ARE REQUIRED FOR THE LOAD SHOWN.

LOAD AS SHOWN

<u>ITEM</u>	<u>WEIGHT (APPROX)</u>
COMBAT CONFIGURED LOAD - - - - -	15,234 LBS
DUNNAGE - - - - -	168 LBS
<u>TOTAL WEIGHT - - - - -</u>	<u>15,402 LBS</u>

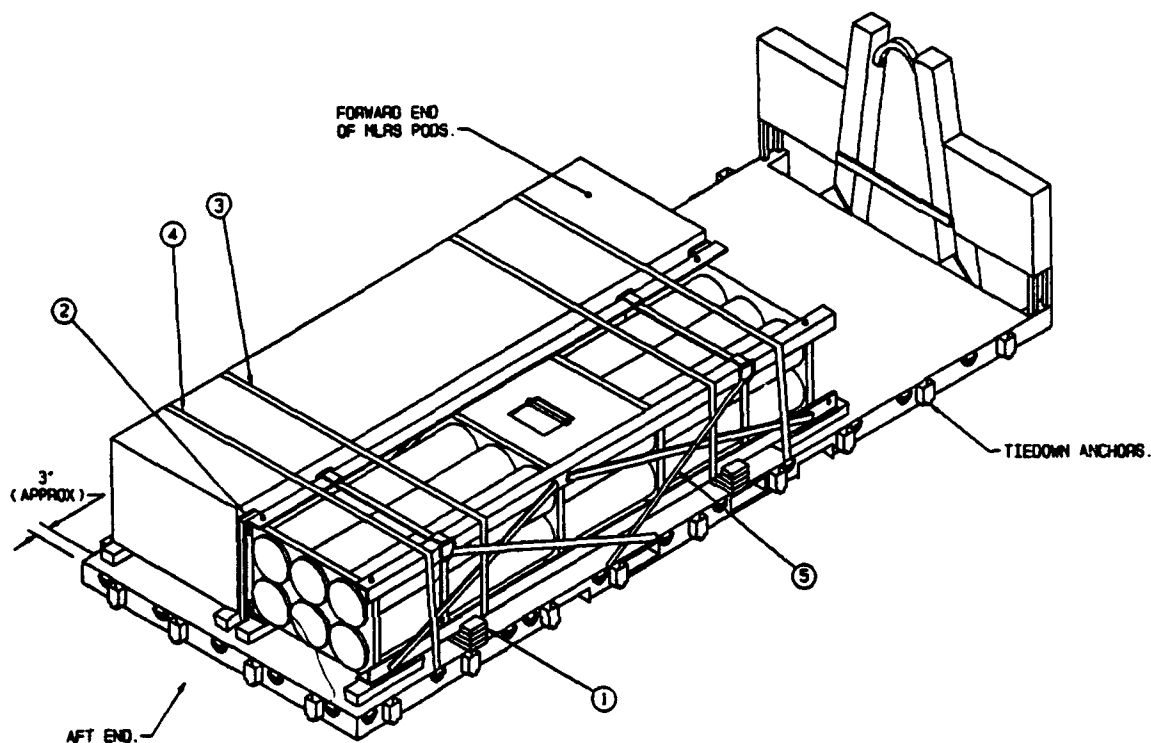

ISOMETRIC VIEW

KEY NUMBERS

- ① SUPPORT ASSEMBLY A (2 REQD). SEE THE DETAIL ON PAGE 19. POSITION AT LOCATIONS SHOWN. SEE SPECIAL NOTES 1 AND 2 ON PAGE 15.
- ② SPACER ASSEMBLY B (2 REQD). SEE DETAIL ON PAGE 19. POSITION ONE ASSEMBLY AS NEAR TO EACH END OF LOAD AS POSSIBLE AND WIRE TIE IN PLACE AT TOP AND BOTTOM OF ASSEMBLY. SEE SPECIAL NOTES 1 AND 3 ON PAGE 11.
- ③ WEB STRAP TIEDOWN ASSEMBLY (2 REQD). INSTALL EACH STRAP TO ENCIRCLE BOTH MLRS PODS AT THE LOCATIONS SHOWN. POSITION STRAP SCUFF PADS AT SHARP EDGES. TAKE UP EXCESS SLACK IN STRAP AND THEN RATCHET TIGHT. NOTE: ASSURE THAT THE SPACER ASSEMBLY B ARE IN POSITION PRIOR TO RATCHETING STRAPS MARKED ② TIGHT.
- ④ WEB STRAP TIEDOWN ASSEMBLY (2 REQD). INSTALL EACH STRAP FROM A TIEDOWN ANCHOR, ON SIDE OF FLATRACK, OVER TOP OF LOAD, TO A TIEDOWN ANCHOR ON OPPOSITE SIDE OF FLATRACK. POSITION STRAP SCUFF PADS AT SHARP EDGES. TAKE UP EXCESS SLACK IN STRAP AND THEN RATCHET TIGHT.
- ⑤ WEB STRAP TIEDOWN ASSEMBLY (4 REQD). INSTALL EACH STRAP FROM A TIEDOWN ANCHOR, ON SIDE OF FLATRACK, TO A LIFT/TIEDOWN RING ON THE FAR END OF THE MLRS POD AS SHOWN. TAKE UP EXCESS SLACK IN STRAP AND THEN RATCHET TIGHT.

COMBAT CONFIGURED LOAD				
DDOIC	ITEM	ITEM QUANTITY	LOAD QUANTITY	TOTAL WEIGHT
H104	MLRS POD 186.0 L X 41.5 W X 33.0 H	12	2 PODS	10.156

SPECIAL NOTES:

1. POSITION TWO MLRS PODS AT AFT END OF FLATRACK AT LOCATION SHOWN. WITH THE FORWARD END OF THE PODS TOWARD THE FORE END OF THE FLATRACK. POSITION THE SPACER ASSEMBLY 8 PIECES AS LOADING PROGRESSES.
2. THE SUPPORT ASSEMBLY A PIECES ARE REQUIRED TO PREVENT THE SKIDS FROM DEFORMING AND TO PROVIDE STABILITY FOR THE PODS DURING TRANSPORT.
3. THE SPACER ASSEMBLY 8 PIECES ARE REQUIRED SO THE MLRS PODS CAN BE POSITIONED IN LINE WITH EACH OTHER Laterally WITHOUT THE LIFT/TIEDOWN RINGS ON ADJACENT PODS CONTACTING EACH OTHER.
4. A TOTAL OF EIGHT WEB STRAP TIEDOWN ASSEMBLIES ARE REQUIRED FOR THE LOAD SHOWN.

LOAD AS SHOWN

<u>ITEM</u>	<u>WEIGHT (APPROX)</u>
COMBAT CONFIGURED LOAD - - - - -	10,156 LBS
DUNNAGE - - - - -	18 LBS
<hr/>	
TOTAL WEIGHT - - - - -	10,174 LBS

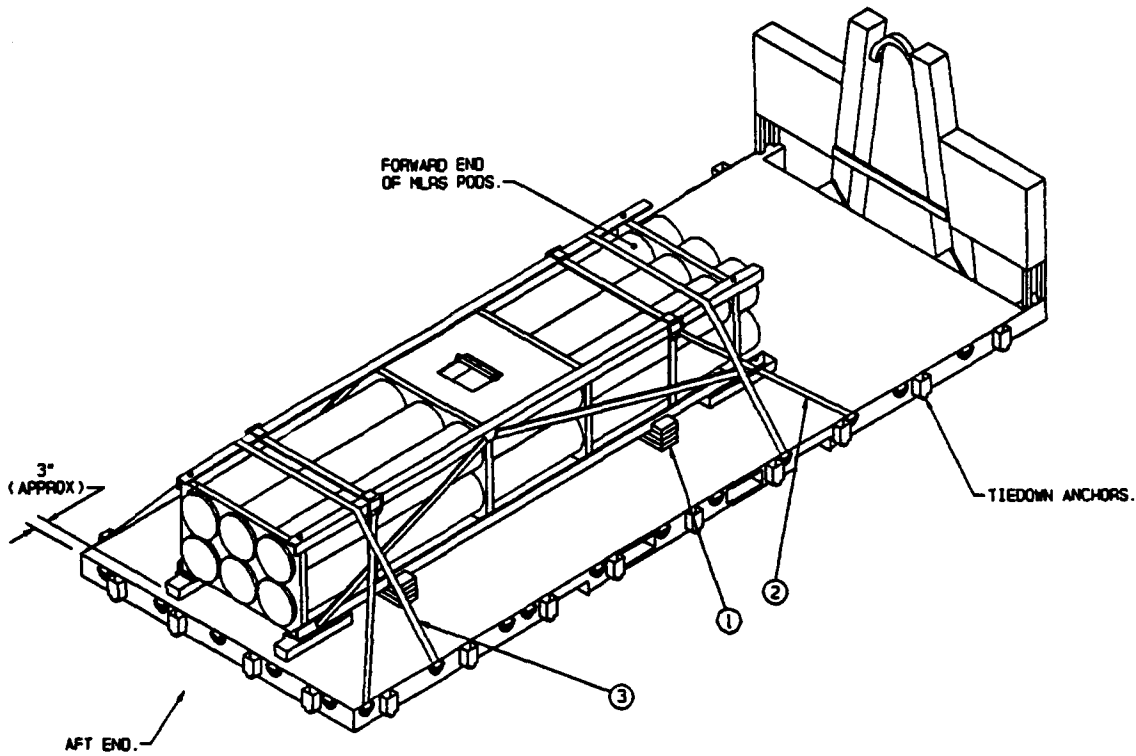

ISOMETRIC VIEW

KEY NUMBERS

- ① SUPPORT ASSEMBLY B (2 REQD). SEE THE DETAIL ON PAGE 19. POSITION AT LOCATIONS SHOWN. SEE SPECIAL NOTES 1 AND 2 ON PAGE 15.
- ② WEB STRAP TIEDOWN ASSEMBLY (4 REQD). INSTALL EACH STRAP FROM A TIEDOWN ANCHOR, ON SIDE OF FLATRACK, TO A LIFT/TIEDOWN RING ON THE FAR END OF THE MLRS POD AS SHOWN. TAKE UP EXCESS SLACK IN STRAP AND THEN RATCHET TIGHT.
- ③ WEB STRAP TIEDOWN ASSEMBLY (2 REQD). INSTALL EACH STRAP FROM A TIEDOWN ANCHOR, ON SIDE OF FLATRACK, OVER TOP OF LOAD, TO A TIEDOWN ANCHOR ON OPPOSITE SIDE OF FLATRACK. POSITION STRAP SCUFF PADS AT SHARP EDGES. TAKE UP EXCESS SLACK IN STRAP AND THEN RATCHET TIGHT.

COMBAT CONFIGURED LOAD

DDIC	ITEM	ITEM QUANTITY	LOAD QUANTITY	TOTAL WEIGHT
H104	MLRS POD 166.0 L X 41.5 W X 33.0 H	6	1 PODS	5.078

SPECIAL NOTES:

1. POSITION ONE MLRS POD AT AFT END OF FLATRACK AT LOCATION SHOWN, WITH THE FORWARD END OF THE PODS TOWARD THE FORE END OF THE FLATRACK.
2. THE SUPPORT ASSEMBLY B PIECES ARE REQUIRED TO PREVENT THE SKIDS FROM DEFORMING AND TO PROVIDE STABILITY FOR THE POD DURING TRANSPORT.
3. A TOTAL OF SIX WEB STRAP TIEDOWN ASSEMBLIES ARE REQUIRED FOR THE LOAD SHOWN.

LOAD AS SHOWN

<u>ITEM</u>	<u>WEIGHT (APPROX)</u>
COMBAT CONFIGURED LOAD - - - - -	5.078 LBS
DUNNAGE - - - - -	18 LBS
<hr/>	
TOTAL WEIGHT - - - - -	10.174 LBS

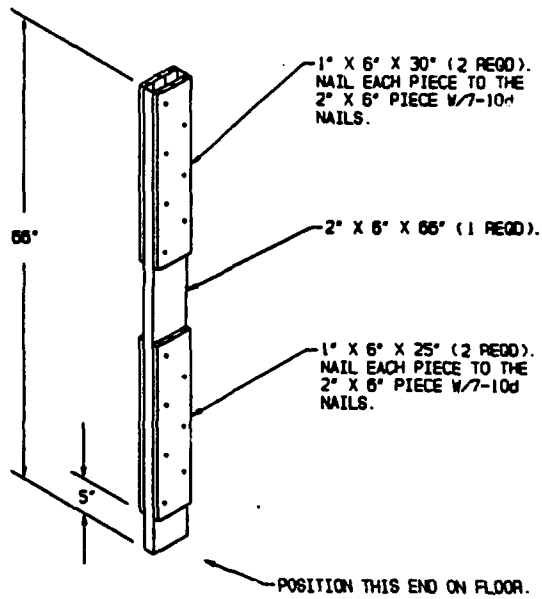

SPACER ASSEMBLY A

FOR USE WITH TWO HIGH LOADS OF MLRS
PODS AS SHOWN IN THE LOAD ON PAGE 10.

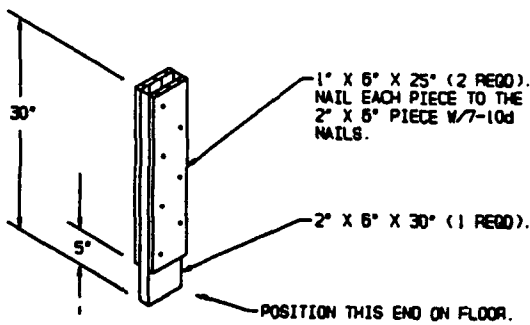

SPACER ASSEMBLY B

FOR USE WITH ONE HIGH LOADS OF MLRS
PODS AS SHOWN IN THE LOAD ON PAGE 12.

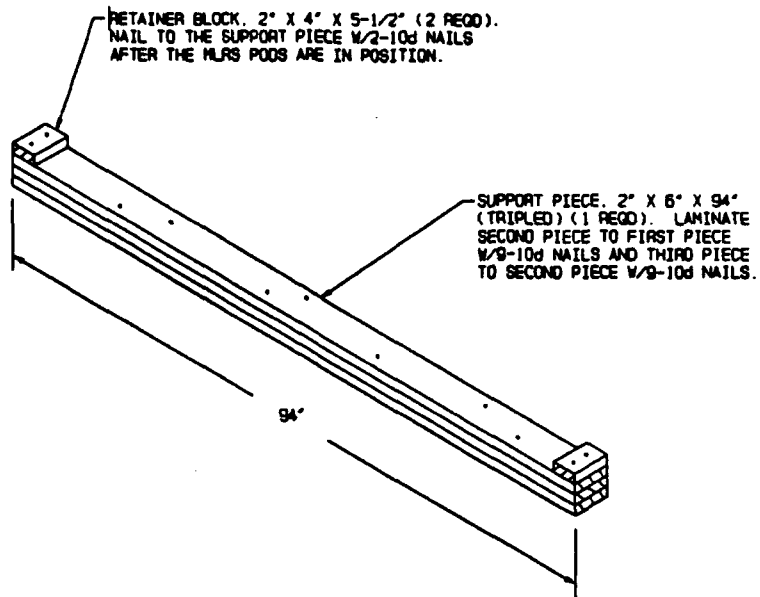

SUPPORT ASSEMBLY A

FOR USE WITH TWO WIDE LOADS OF MLRS
POOS AS SHOWN IN THE LOAD ON PAGE 10.

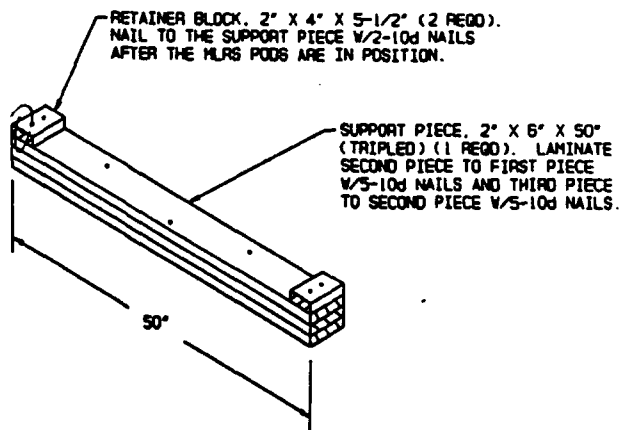

SUPPORT ASSEMBLY B

FOR USE WITH TWO WIDE LOADS OF MLRS
POOS AS SHOWN IN THE LOAD ON PAGE 12.

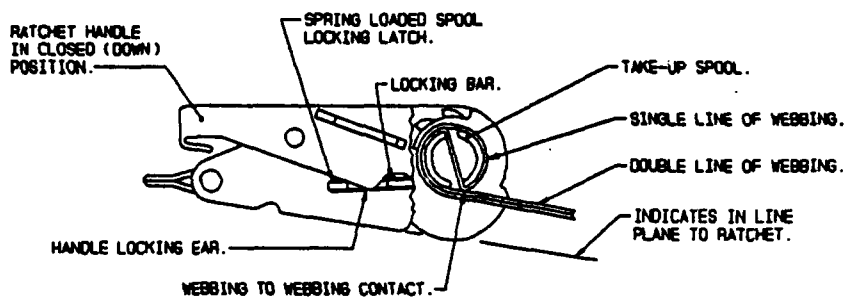

STEP 1

IN THIS VIEW PART OF THE RATCHET HOUSING IS SHOWN BROKEN AWAY TO DEPICT WEBBING-TO-WEBBING CONTACT ON THE TAKE-UP SPOOL OF THE RATCHET. WEBBING-TO-WEBBING CONTACT IS ACHIEVED WHEN THE OPERATOR HOLDS THE DOUBLE LINE OF WEBBING IN AN "IN LINE PLANE TO THE RATCHET" AND IT MAKES CONTACT WITH THE SINGLE LINE OF WEBBING.

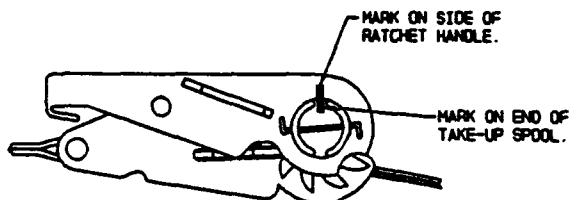

STEP 2

THIS VIEW DEPICTS THE LOCATION OF THE FIXED MARK ON THE RATCHETING HANDLE. WITH ANOTHER MATCHING MARK ON THE TAKE-UP SPOOL. AFTER WEBBING-TO-WEBBING CONTACT HAS BEEN MADE.

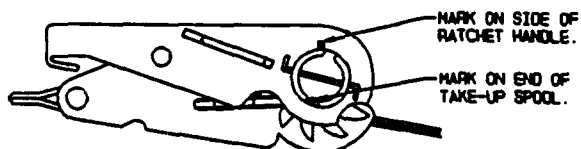

STEP 3

THIS VIEW DEPICTS THE LOCATION OF THE MARK ON THE END OF THE TAKE-UP SPOOL AFTER THE SPOOL HAS BEEN ROTATED ONE-HALF TURN, AFTER WEBBING-TO-WEBBING CONTACT HAS BEEN MADE.

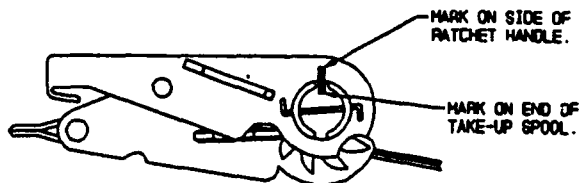

STEP 4

THIS VIEW DEPICTS THE LOCATION OF THE MARK ON THE END OF THE TAKE-UP SPOOL AFTER THE SPOOL HAS BEEN ROTATED ONE FULL TURN, AFTER WEBBING-TO-WEBBING CONTACT HAS BEEN MADE.

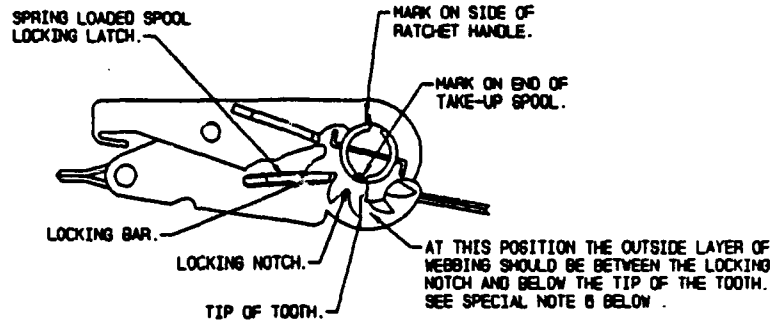

STEP 5

THIS VIEW DEPICTS THE LOCATION OF THE MARK ON THE END OF THE TAKE-UP SPOOL AFTER THE SPOOL HAS BEEN ROTATED ONE AND ONE-HALF TURNS, AFTER WEBBING-TO-WEBBING CONTACT HAS BEEN MADE. ALSO IN THIS VIEW, PART OF THE RATCHET HANDLE IS BROKEN AWAY TO SHOW THE LOCKING BAR FULLY SEATED IN THE MATCHING LOCKING NOTCH (SPROCKET GEAR TEETH).

SPECIAL NOTES:

1. THE PURPOSE OF THE RATCHET DETAILS ON PAGE 20 AND THE DETAIL AND NOTES ON THIS PAGE ARE TO AUGMENT THE GUIDANCE SET FORTH WITHIN GENERAL NOTE "E" ON PAGE 2.
2. THE REQUIREMENTS FOR 1/2 BUT NOT MORE THAN 1-1/2 WRAPS OF STRAP ON THE TAKE-UP SPOOL OF THE TENSIONING RATCHET, AS SPECIFIED WITHIN GENERAL NOTE "E" ON PAGE 2, ACTUALLY MEANS 1/2 TO 1-1/2 WRAPS OF DOUBLE WEBBING. ALSO, THE 1/2 TO 1-1/2 WRAPS (TURNS) ARE TO BE ACCOMPLISHED ONLY AFTER ENOUGH WEBBING HAS BEEN WOUND ONTO THE SPOOL TO ACHIEVE A WEBBING-TO-WEBBING CONFIGURATION, AS SHOWN IN THE "STEP 1" DETAIL.
3. ONE METHOD THAT CAN BE USED TO ENSURE THAT THE 1/2 TO 1-1/2 WRAPS ARE WOUND ONTO THE TAKE-UP SPOOL, AFTER WEBBING-TO-WEBBING CONTACT HAS BEEN MADE, IS TO PLACE A FIXED MARK (PAINT OR SIMILAR MATERIAL) ON THE SIDE OF THE RATCHETING HANDLE, WITH THE HANDLE IN ITS CLOSED (DOWN) POSITION, AND ANOTHER SHORT MATCHING MARK ON THE END OF THE SPOOL, AS SHOWN IN THE "STEP 2" DETAIL. AS THE SPOOL IS ROTATED TO TENSION A TIEDOWN STRAP ASSEMBLY, THE NUMBER OF WRAPS (TURNS) CAN BE DETERMINED VISUALLY BY COMPARING THE "MARK" LOCATION ON THE SPOOL TO THE "MARK" LOCATION ON THE RATCHETING HANDLE WITH THE HANDLE IN CLOSED POSITION. SEE THE "STEP 3", "STEP 4" AND "STEP 5" DETAILS.
4. ANOTHER METHOD THAT CAN BE USED TO ENSURE THAT THE 1/2 TO 1-1/2 WRAPS ARE ACHIEVED, AFTER WEBBING-TO-WEBBING CONTACT HAS BEEN MADE, IS TO COUNT THE AUDIBLE CLICKS MADE BY THE RATCHET ASSEMBLY AS A WEB STRAP ASSEMBLY IS BEING TENSIONED. THE RATCHET ASSEMBLY ON MOST WEB STRAP ASSEMBLIES HAVE 11 TEETH ON THE GEARLIKE DEVICE ON EACH END OF THE TAKE-UP SPOOL; SOME OTHER STRAP ASSEMBLIES HAVE ONLY 9 TEETH. THEREFORE, AFTER INITIAL WEBBING-TO-WEBBING CONTACT HAS BEEN MADE, ROTATE (TURN) THE SPOOL THROUGH A MINIMUM OF 6 TO A MAXIMUM OF 16 CLICKS (1/2 TO 1-1/2 WRAPS) WHEN THE GEAR HAS 11 TEETH, AND ROTATE (TURN) THE SPOOL THROUGH A MINIMUM OF 5 TO A MAXIMUM OF 13 CLICKS (1/2 TO 1-1/2 WRAPS) IF THE GEAR HAS 9 TEETH.

(CONTINUED AT RIGHT)

(SPECIAL NOTES CONTINUED)

5. AFTER A STRAP ASSEMBLY HAS BEEN PROPERLY TENSIONED, CARE MUST BE EXERCISED TO ASSURE THAT THE TAKE-UP SPOOL LOCKING LATCH (SPRING LOADED DEVICE WITH A LOCKING BAR ON EACH SIDE OF THE RATCHET ASSEMBLY) IS FULLY SEATED ON BOTH SIDES IN MATCHING LOCKING NOTCHES, WHICH ARE SIMILAR TO SPROCKET GEAR TEETH, THAT ARE LOCATED ON EACH END OF THE TAKE-UP SPOOL. SEE "STEP 5" DETAIL ABOVE. THE LOCKING LATCH IS "FULLY SEATED" WHEN THE HANDLE WILL CLOSE AND THE LOCKING BAR, OR SIMILAR DEVICE ON THE HANDLE, PREVENTS THE ACCIDENTAL WITHDRAWAL OF THE LOCKING LATCH. SEE "STEP 1" DETAIL. IF THE FULLY SEATED CONDITION CANNOT BE ACHIEVED, THE STRAP MUST BE RELEASED AND HAND RETENSIONED AS TIGHT AS POSSIBLE TO ACHIEVE THE FULLY SEATED CONDITION.
6. ANOTHER VISUAL METHOD OF DETERMINING WHEN THERE IS 1/2 TO 1-1/2 WRAPS OF WEBBING ON THE TAKE-UP SPOOL, AFTER INITIAL WEBBING-TO-WEBBING CONTACT HAS BEEN MADE, IS TO LOOK AT THE SPOOL. WHEN A TIEDOWN IS COMPLETE, THE STRAP WEBBING ON THE SPOOL OF THE RATCHET SHOULD BE ABOVE THE LOWER CURVE OF THE LOCKING NOTCH, AND SHOULD BE BELOW THE TIPS OF THE TEETH OF THE RATCHET AS IDENTIFIED IN "STEP 5" ABOVE. IT SHOULD BE NOTED THAT ANY PROCEDURES THAT ENSURE PROPER TENSIONING ARE ACCEPTABLE AND METHODS ON THE DRAWING ONLY PROVIDE SOME METHODS.