

AD-A259 935



2

FINAL REPORT
MARCH 1991

REPORT NO. 91-11

FIRST ARTICLE TESTING (FAT)
OF 105MM PALLETS
AND ADAPTERS

DTIC
ELECTE
JAN 22 1993
S E D

Prepared for:
U.S. Army Armament Research, Development
and Engineering Center
ATTN: SMCAR-AEP
Picatinny Arsenal, NJ 07806-5000

Distribution Unlimited

36
pp

93-01144



U.S. ARMY
ARMAMENT
MUNITIONS
CHEMICAL COMMAND
U.S. ARMY DEFENSE AMMUNITION
CENTER AND SCHOOL



VALIDATION ENGINEERING DIVISION
SAVANNA, ILLINOIS 61074-9639

AVAILABILITY NOTICE

A copy of this report will be furnished each attendee on automatic distribution. Additional copies or authority for reprinting may be obtained by written request from Director, U.S. Army Defense Ammunition Center and School, ATTN: SMCAC-DEV, Savanna, IL 61074-9639.

DISTRIBUTION INSTRUCTIONS

Destroy this report when no longer needed. Do not return.

Citation of trade names in this report does not constitute an official endorsement.

The information contained herein will not be used for advertising purposes.

REPORT DOCUMENTATION PAGE

Form Approved
OMB No. 0704-0188

1a. REPORT SECURITY CLASSIFICATION UNCLASSIFIED		1b. RESTRICTIVE MARKINGS	
2a. SECURITY CLASSIFICATION AUTHORITY		3. DISTRIBUTION / AVAILABILITY OF REPORT UNLIMITED	
2b. DECLASSIFICATION / DOWNGRADING SCHEDULE			
4. PERFORMING ORGANIZATION REPORT NUMBER(S) 91-11		5. MONITORING ORGANIZATION REPORT NUMBER(S)	
6a. NAME OF PERFORMING ORGANIZATION U.S. Army Defense Ammunition Center and School	6b. OFFICE SYMBOL (if applicable) SMCAC-DEV	7a. NAME OF MONITORING ORGANIZATION	
6c. ADDRESS (City, State, and ZIP Code) ATTN: SMCAC-DEV Savanna, IL 61074-9639		7b. ADDRESS (City, State, and ZIP Code)	
8a. NAME OF FUNDING / SPONSORING ORGANIZATION U.S. Army Armament Research, Development and Engineering Center	8b. OFFICE SYMBOL (if applicable) SMCAR-AEP	9. PROCUREMENT INSTRUMENT IDENTIFICATION NUMBER	
8c. ADDRESS (City, State, and ZIP Code) ATTN: SMCAR-AEP Picatinny Arsenal, NJ 07806-5000		10. SOURCE OF FUNDING NUMBERS	
		PROGRAM ELEMENT NO.	PROJECT NO.
		TASK NO.	WORK UNIT ACCESSION NO.
11. TITLE (Include Security Classification) First Article Testing (FAT) of 105mm Pallets and Adapters			
12. PERSONAL AUTHOR(S) Quinn D. Hartman			
13a. TYPE OF REPORT Final	13b. TIME COVERED FROM _____ TO _____	14. DATE OF REPORT (Year, Month, Day) 1991 March	15. PAGE COUNT
16. SUPPLEMENTARY NOTATION			
17. COSATI CODES		18. SUBJECT TERMS (Continue on reverse if necessary and identify by block number)	
FIELD	GROUP	SUB-GROUP	
19. ABSTRACT (Continue on reverse if necessary and identify by block number) The U.S. Army Defense Ammunition Center and School (USADACS) was tasked by the U.S. Army Armament Research, Development and Engineering Center (ARDEC), Packaging Division (SMCAR-AEP), Picatinny Arsenal, NJ, to develop an ammunition unit load for the shipping and storage of 105mm metal PA117 containers. The metal pallet and adapters unitization procedures were designed by USADACS, Supply Engineering Division (SMCAC-DES); and USADACS, Validation Engineering Division (SMCAC-DEV), verified that both the unitization procedures and the first article production sample pallets and adapters could satisfy MIL-STD-1660, Design Criteria for Ammunition Unit Loads.			
20. DISTRIBUTION / AVAILABILITY OF ABSTRACT <input checked="" type="checkbox"/> UNCLASSIFIED/UNLIMITED <input type="checkbox"/> SAME AS RPT. <input type="checkbox"/> DTIC USERS		21. ABSTRACT SECURITY CLASSIFICATION UNCLASSIFIED	
22a. NAME OF RESPONSIBLE INDIVIDUAL JEROME H. KROHN		22b. TELEPHONE (Include Area Code) 815-273-8929	22c. OFFICE SYMBOL SMCAC-DEV

U.S. ARMY DEFENSE AMMUNITION CENTER AND SCHOOL
 VALIDATION ENGINEERING DIVISION
 SAVANNA, IL 61074-9639

REPORT NO. 91-11
 FIRST ARTICLE TESTING (FAT) OF
 105MM PALLETS AND ADAPTERS

TABLE OF CONTENTS

PART	PAGE NO.
1. INTRODUCTION	1-1
A. BACKGROUND	1-1
B. AUTHORITY	1-1
C. OBJECTIVE	1-1
2. ATTENDEES	2-1
3. TEST PROCEDURES	3-1
4. TEST EQUIPMENT	4-1
5. TEST RESULTS	5-1
6. CONCLUSIONS AND RECOMMENDATIONS	6-1
7. TEST SYNOPSES	7-1
8. PHOTOGRAPHS	8-1
9. DRAWINGS	9-1

Justification	<input checked="" type="checkbox"/> <input type="checkbox"/> <input type="checkbox"/>
By	
Distribution /	
Availability Codes	
Dist	Avail and/or Special
<i>A-1</i>	

PART 1

INTRODUCTION

A. **BACKGROUND.** The U.S. Army Defense Ammunition Center and School (USADACS), Validation Engineering Division (SMCAC-DEV), was tasked by the U.S. Army Armament Research, Development and Engineering Center (ARDEC), Packaging Division (SMCAR-AEP), to develop an ammunition unit load for the shipping and storage of 105mm metal PA117 containers in a configuration of six containers wide by five containers high. The design and development of the pallet, top adapter, and bottom adapter was accomplished by USADACS, Supply Engineering Division (SMCAC-DES). The procedures for the unitization of the PA117 containers on the metal pallet were developed by USADACS, Transportation Engineering Division (SMCAC-DET). The validation of both the first article sample pallets and adapter designs and the unitization procedures was performed by USADACS, Validation Engineering Division (SMCAC-DEV). First article production samples were produced by Helgesen Industries, Incorporated, Hartford, WI. Procedures used for validating the pallet and adapter designs and unitization procedures were extracted from MIL-STD-1660, Design Criteria for Ammunition Unit Loads.

B. **AUTHORITY.** This test was conducted in accordance with mission responsibilities delegated by the U.S. Army Armament, Munitions and Chemical Command (AMCCOM), Rock Island, IL.

C. **OBJECTIVE.** The objective of these tests was to verify that the first article production samples produced by Helgesen Industries, Incorporated, satisfied the requirements for an ammunition unit load as set forth in MIL-STD-1660, Design Criteria for Ammunition Unit Loads.

PART 2

ATTENDEES

Quinn D. Hartman
Test Engineer
DSN 585-8992
815-273-8992

U.S. Army Defense Ammunition Center
and School
ATTN: SMCAC-DEV
Savanna, IL 61074-9639

Steve L. VonThun
Engineering Draftsman
DSN 585-8929
815-273-8929

U.S. Army Defense Ammunition Center
and School
ATTN: SMCAC-DEV
Savanna, IL 61074-9639

Sandra M. Schultz
Industrial Engineer
DSN 585-8086
815-273-8086

U.S. Army Defense Ammunition Center
and School
ATTN: SMCAC-DES
Savanna, IL 61074-9639

Ron Marshall
414-673-4444

Helgesen Industries, Incorporated
7261 Highway 60 West
Hartford, WI 53027

Gene Conley
414-673-4444

Helgesen Industries, Incorporated
7261 Highway 60 West
Hartford, WI 53027

PART 3

TEST PROCEDURES

The test procedures outlined in this section were extracted from MIL-STD-1660, Design Criteria for Ammunition Unit Loads, 8 April 1977. This standard identifies nine steps that a unitized load must undergo if it is considered to be acceptable. The four tests that were conducted on the test specimen are synopsized below.

1. SUPERIMPOSED LOAD TEST. The unit load shall be loaded to simulate a stack of identical unit loads stacked 16 feet high for a period of one hour, as specified in Method 5016, Federal Standard 101. This stacking load is simulated by subjecting the unit load to a compression of weight equal to an equivalent 16-foot stacking height. The compression load is calculated in the following manner. The unit load weight is multiplied by 192 minus the unit height in inches, divided by the unit height in inches, then multiplied by a safety factor of two. The resulting number is the equivalent compressive force of a 16-foot-high load.

2. REPETITIVE SHOCK TEST. The repetitive shock test shall be conducted in accordance with Method 5019, Federal Standard 101. The test procedure is as follows: The test specimen shall be placed on, but not fastened to the platform. With the specimen in one position, vibrate the platform at 1/2-inch amplitude (1-inch double amplitude) starting at a frequency of about 3 cycles-per-second. Steadily increase the frequency until the package leaves the platform. The resonant frequency is achieved when a 1/16-inch-thick feeler gage may be momentarily slid freely between every point on the specimen in contact with the platform at some instance during the cycle or a platform acceleration achieves $1 \pm 0.1G$. Midway into the testing period, the specimen shall be rotated 90 degrees, and the test continued for the duration. Unless failure occurs, the total time of vibration shall be two hours if the specimen is tested in one position; and, if tested in more than one position, the total time shall be three hours.

3. EDGEWISE ROTATIONAL DROP TEST. This test shall be conducted by using the procedures of Method 5008, Federal Standard 101. The procedure for the edgewise rotational drop test is as follows: The specimen shall be placed on its skids with one end of the pallet supported on a beam 4 1/2-inches high. The height of the beam shall be increased, if necessary, to ensure that there will be no support for the skids between the ends of the pallet when dropping takes place, but should not be high enough to cause the pallet to slide on the supports when the dropped end is raised for the drops. The unsupported end of the pallet shall then be raised and allowed to fall freely to the concrete, pavement, or similar underlying surface from a prescribed height. Unless otherwise specified, the height of drop for level A protection shall conform to the following tabulation.

GROSS WEIGHT NOT EXCEEDING <u>(POUNDS)</u>	DIMENSIONS ON ANY EDGE NOT EXCEEDING <u>(INCHES)</u>	HEIGHT OF DROP LEVEL A PROTECTION <u>(INCHES)</u>
600 lbs.	72	36
3,000 lbs.	no limit	24
no limit	no limit	12

4. INCLINE-IMPACT TEST. This test shall be conducted by using the procedure of Method 5023, Incline-Impact Test of Federal Standard 101. The procedure for the incline-impact test is as follows: The specimen shall be placed on the carriage with the surface or edge which is to be impacted projecting at least two inches beyond the front end of the carriage. The carriage shall be brought to a predetermined position on the incline and released. If it is desired to concentrate the impact on any particular position on the container, a 4- by 4-inch timber may be attached to the bumper in the desired position before the test. No part of the timber shall be struck by the carriage. The position of the container on the carriage and the sequence in which surfaces and

edges are subjected to impacts may be at the option of the testing activity and will depend upon the objective of the tests. When the test is to determine satisfactory requirements for a container or pack, and, unless otherwise specified, the specimen shall be subjected to one impact on each surface that has each dimension less than 9.5 feet. Unless otherwise specified, the velocity at time of impact shall be 7 feet-per-second.

PART 4

TEST EQUIPMENT

1. COMPRESSION TESTER.

- a. Manufacturer: Ormond Manufacturing
- b. Platform: 60 inches by 60 inches
- c. Compression Limit: 50,000 pounds
- d. Tension Limit: 50,000 pounds

2. TRANSPORTATION SIMULATOR.

- a. Manufacturer: Gaynes Laboratory
- b. Capacity: 6,000-pound pallet
- c. Displacement: 1/2-inch Amplitude
- d. Speed: 50 to 400 rpm
- e. Platform: 5 foot by 8 foot

3. INCLINED RAMP.

- a. Manufacturer: Conbur Incline
- b. Type: Impact Tester
- c. Grade: 10 percent Incline
- d. Length: 12-foot Incline

PART 5

TEST RESULTS

A. The FAT of the initial three pallet and adapter sets submitted by Helgesen Industries, Incorporated, was conducted 26 - 28 March 1991. A full set of MIL-STD-1660 tests, as outlined in part 2, was conducted on each ammunition load (see part 7 for a detailed synopsis of the testing results). Results from these tests indicated that the pins in the bottom adapter were not strong enough to prevent the load from shifting off of the pallet during the incline-impact test. As a result of incline-impact testing, 7 of the 12 adapter pins were sheared off and 3 were bent. The failure of the bottom adapter pins resulted in a failure of the first three pallet and adapter sets submitted by Helgesen Industries, Incorporated.

B. An investigation into the pin failures found that a material change had been made between the prototype pallets and the first article production pallets. The prototype pallets that successfully passed MIL-STD-1660 testing utilized 1018 grade steel for the adapter pins while the initial first article samples utilized 12L14 grade steel for the adapter pins. After discussions with Helgesen Industries, Incorporated, about the different steels that had been used, Helgesen Industries, Incorporated, decided to reproduce three new sets of pallets and adapters utilizing 1018 grade steel for the bottom adapter pins.

C. The FAT of the second set of pallets and adapters submitted by Helgesen Industries, Incorporated, was conducted 9 - 15 April 1991. During pre-test inspection, a manufacturing error (which was not present on the original first article samples) was noted on each of the pallet adapter tops that were shipped with the second set of FAT samples. The lifting ring assemblies at the bell end of the containers were assembled with the lifting ring retainer placed too close to the outside edge of the side rail on the adapter top. This manufacturing error inhibited the lifting

ring from being rotated to the 75-85 degree angle specified in the drawings. As before, the three ammunition loads were tested using MIL-STD-1660 tests (as outlined in part 3).

MIL-STD-1660 testing resulted in minor damage during the slinging test as a result of the manufacturing error and minor bending of one of the bottom adapter pins on each bottom adapter.

PART 6

CONCLUSIONS AND RECOMMENDATIONS

1. CONCLUSIONS. The initial set of first article samples produced by Helgesen Industries, Incorporated, failed MIL-STD-1660 testing. The initial samples were considered unacceptable because the bottom adapter pins sheared off during the incline-impact test. Failure of the bottom adapter pins was attributed to the 12L14 grade steel that was used to manufacture the bottom adapter pins. The prototype pallets that passed MIL-STD-1660 testing were fabricated using 1018 grade steel for the bottom adapter pins. The second set of first article samples, submitted by Helgesen Industries, Incorporated, utilized 1018 grade steel. While there was a minor manufacturing error with the second set of samples, the second set of first article pallets and adapters submitted by Helgesen Industries, Incorporated, successfully passed MIL-STD-1660 testing.

2. RECOMMENDATIONS. Since the second set of first article pallets and adapters submitted by Helgesen Industries, Incorporated, successfully passed all phases of MIL-STD-1660 testing with only minor damage, USADACS, Validation Engineering Division, recommends that the pallets and adapters produced by Helgesen Industries, Incorporated, be approved for U.S. Army (USA)-wide use to ship and store ammunition, provided the bottom adapter pins are not constructed with the alternate materials, 12L14 or 11L17 grade steel, and the manufacturing error on the top lift adapter be corrected.

PART 7

TEST SYNOPSES

1. Initial first article samples, pallet 1:

a. Compression Test. The test pallet was compressed under a load of 16,800 pounds for a period of 1 hour. Prior to compression the pallet was 41 inches high. After compression, the pallet was 40 5/8-inches high. The load straps were loosened slightly due to the compaction of the load.

b. Transportation Simulator Test. The test pallet was vibrated 90 minutes in the longitudinal orientation at 180 rpm and 90 minutes in the lateral position at 190 rpm. No damage was sustained by the test pallet during this test.

c. Edgewise Rotational Drop Test. The test pallet had each edge of the pallet raised to a height of 24 inches from the floor and then dropped. During the drop testing, the test pallet was bent slightly along the longitudinal axis. All stacking pins on the containers remained engaged throughout the drop testing.

d. Sling Test. The test pallet was lifted by the top lift adapter with five different lifting configurations; four corner lift, three corner lift, two adjacent corner lifts, two diagonal corner lifts, and a one corner lift. The top lift adapter sustained no damage during the slinging tests.

e. Incline-Impact Test. The test pallet was incline-impacted on each side of the pallet from a height of 8 feet. No external damage was noted during the impacts. After disassembly and inspection, however, the bottom adapter was found to have two sheared and one bent bottom adapter pins. This was considered a failure because the bottom adapter pins are essential in keeping the load from shifting independently of the pallet.

2. Initial first article samples, pallet 2:

a. Compression Test. This test pallet was also compressed under a load of 16,800 pounds for a period of 1 hour. Prior to compression the pallet was 41 inches high. After compression, the pallet retained the initial height of 41 inches. No damage or loosening of the load was noted.

b. Transportation Simulator Test. This test pallet was vibrated 90 minutes in the longitudinal orientation at 190 rpm and 90 minutes in the lateral position at 185 rpm. No damage was sustained by the test pallet during this test.

c. Edgewise Rotational Drop Test. This test pallet had each edge of the pallet raised to a height of 24 inches from the floor and then dropped. During the first longitudinal and lateral drops, the test pallet was bent slightly in both the longitudinal and lateral axes. Also, one of the stacking pins at the bell end of the PA117 container became disengaged from an upper container. During the two drops, the container shifted back into position and the stacking pin re-engaged with the upper container. The only permanent damage from this test was the minor bending of the pallet and adapters in both the longitudinal and lateral axes.

d. Sling Test. This test pallet was lifted by the top lift adapter with the five different lifting configurations; four corner lift, three corner lift, two adjacent corner lifts, two diagonal corner lifts, and a one corner lift. No damage was sustained during the slinging test.

e. Incline-Impact Test. This test pallet was incline-impacted on each side of the pallet from a height of 8 feet. As with test pallet 1, no external damage was noted during the impacts. Dissassembly revealed that the bottom adapter had one sheared and two bent bottom adapter pins. This pallet was also considered a failure because the bottom adapter pins would no longer keep the load from shifting independently of the pallet.

3. Initial first article samples, pallet 3:

a. Compression Test. This test pallet was compressed under a load of 16,800 pounds for a period of 1 hour. Prior to compression the pallet was 40 3/4-inches high. After compression, the pallet retained the initial height of 40 3/4-inches. No damage or loosening of the load was noted.

b. Transportation Simulator Test. This test pallet was vibrated 90 minutes in the longitudinal orientation at 190 rpm and 90 minutes in the lateral position at 190 rpm. No damage was sustained by the test pallet during this test.

c. Edgewise Rotational Drop Test. This test pallet had each edge of the pallet raised to a height of 24 inches from the floor and then dropped. As with test pallet 2, this test pallet had one of the PA117 container's stacking pins become disengaged during the first two edgewise rotational drops and was then re-engaged during the last two drop tests. Minor bending in the longitudinal orientation was the only permanent damage during this test.

d. Sling Test. This test pallet was lifted by the top lift adapter with the five different lifting configurations; four corner lift, three corner lift, two adjacent corner lifts, two diagonal corner lifts, and a one corner lift. No damage was sustained during the slinging test.

e. Incline-Impact Test. This test pallet was incline-impacted on each side of the pallet from a height of 8 feet. As with test pallets 1 and 2, no external damage was noted during the impacts. Dissassembly revealed that the bottom adapter had all four adapter pins sheared off. This pallet was considered a failure because the bottom adapter pins would no longer keep the load from shifting independently of the pallet.

4. Second set of first article samples, pallet 1:

a. Pre-Inspection. During pre-inspection, this pallet was noted to have a manufacturing defect on the top pallet adapter. The lifting ring assemblies at the bell end of the containers were assembled with the lifting ring retainer placed too close to the outside edge of the side rail on the adapter top. This manufacturing error prohibited the lifting ring from being rotated to the 75-85 degree angle specified in the drawings.

b. Compression Test. This test pallet was compressed under a load of 16,800 pounds for a period of 1 hour. Prior to compression the pallet was 41 inches high. After compression, the pallet was 40 1/2-inches high. No damage or significant loosening of the load was noted.

c. Transportation Simulator Test. This test pallet was vibrated 90 minutes in the longitudinal orientation at 190 rpm and 90 minutes in the lateral position at 175 rpm. No damage was sustained by the test pallet during this test.

d. Edgewise Rotational Drop Test. This test pallet, again, had each edge of the pallet raised to a height of 24 inches from the floor and then dropped. Post test inspection noted a very minor bending of the pallet in the longitudinal direction.

e. Sling Test. This test pallet was lifted by the top lift adapter with five different lifting configurations; four corner lift, three corner lift, two adjacent corner lifts, two diagonal corner lifts, and a one corner lift. The top lift adapter sustained minor damage due to the lifting ring manufacturing error.

f. Incline-Impact Test. This test pallet was incline-impacted on each side of the pallet from a height of 8 feet. No external damage was noted during the impacts. After disassembly and

inspection, the bottom adapter was found to have only sustained a minor bending in one of the adapter pins.

5. Second set of first article samples, pallet 2:

a. Pre-Inspection. This test pallet was found to have the same defect as test pallet 1 of the second set of first article samples.

b. Compression Test. This test pallet was compressed under a load of 16,800 pounds for a period of 1 hour. Prior to compression the pallet was 41 inches high. After compression, the pallet returned to a height of 40 1/2-inches. No damage or loosening of the load was noted.

c. Transportation Simulator Test. This test pallet was vibrated 90 minutes in the longitudinal orientation at 175 rpm and 90 minutes in the lateral position at 185 rpm. No damage was sustained by this test pallet during this test.

d. Edgewise Rotational Drop Test. This test pallet had each edge of the pallet raised to a height of 24 inches from the floor and then dropped. The test pallet sustained minor bending of the pallet in both the longitudinal and lateral directions.

e. Sling Test. This test pallet was lifted by the top lift adapter with five different lifting configurations; four corner lift, three corner lift, two adjacent corner lifts, two diagonal corner lifts, and a one corner lift. This top lift adapter also sustained minor damage due to the lifting ring manufacturing error.

f. Incline-Impact Test. This test pallet was incline-impacted on each side of the pallet from a height of 8 feet. No external damage was noted during the impacts. Again, disassembly and inspection revealed one bottom adapter was found to have sustained minor bending.

6. Second set of first article samples, pallet 3:

a. Pre-Inspection. This test pallet was found to have the same defect as test pallets 1 and 2 of the second set of first article samples.

b. Compression Test. This test pallet was compressed under a load of 16,800 pounds for a period of 1 hour. Prior to compression the pallet was 41 inches high. After compression, the pallet returned to a height of 40 1/2-inches. No damage or loosening of the load was noted.

c. Transportation Simulator Test. This test pallet was vibrated 90 minutes in the longitudinal orientation at 185 rpm and 90 minutes in the lateral position at 175 rpm. No damage was sustained by this test pallet during this test.

d. Edgewise Rotational Drop Test. This test pallet had each edge of the pallet raised to a height of 24 inches from the floor and then dropped. No damage was sustained by the pallet during any of the drops.

e. Sling Test. This test pallet was lifted by the top lift adapter with five different lifting configurations; four corner lift, three corner lift, two adjacent corner lifts, two diagonal corner lifts, and a one corner lift. The test pallet sustained minor damage due to the lifting ring manufacturing error.

f. Incline-Impact Test. This test pallet was incline-impacted on each side of the pallet from a height of 8 feet. As with test pallets 1 and 2, no external damage was noted during the impacts. Again, disassembly and inspection revealed one bottom adapter was found to have sustained minor bending.

PART 8

PHOTOGRAPHS

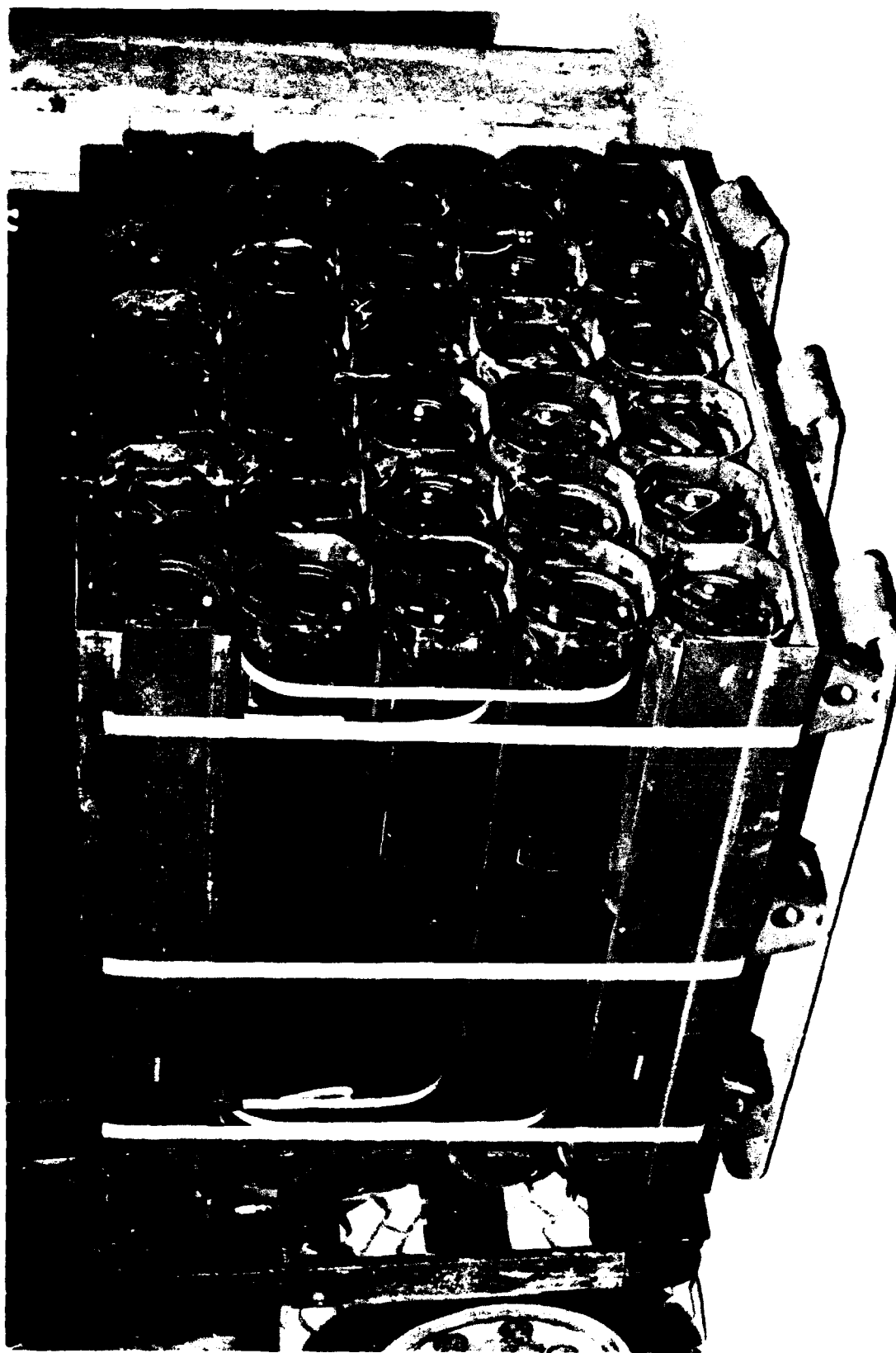

U.S. ARMY DEFENSE AMMUNITION CENTER AND SCHOOL - SAVANNA, IL

Photo No. AO317-SPN-91-173-1922. This photo shows the overall assembly of the 105mm pallet with adapters.

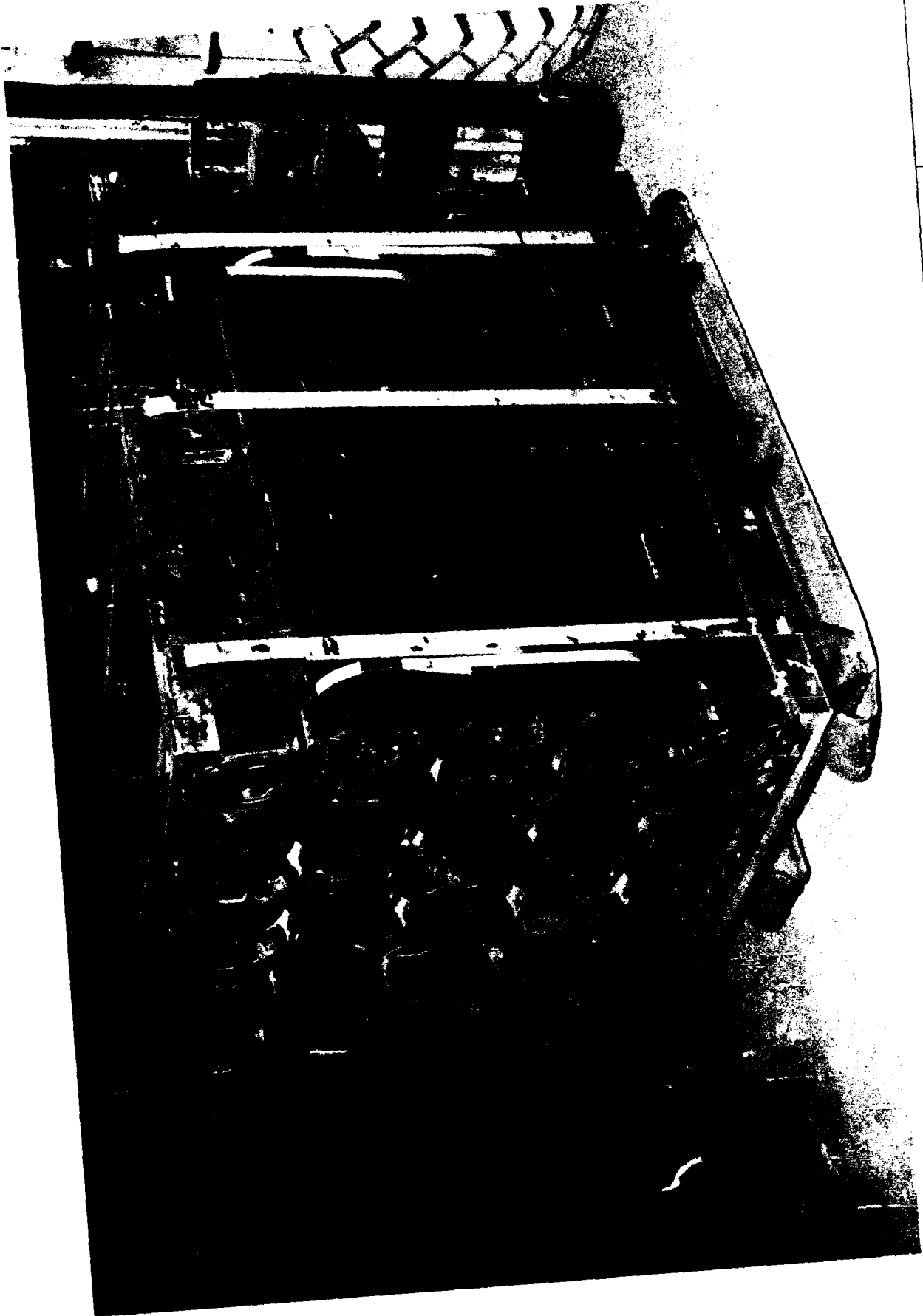

U.S. ARMY DEFENSE AMMUNITION CENTER AND SCHOOL - SAVANNA, IL

Photo No. AO317-SPN-91-1926. This photo shows an additional view of the 105mm pallet with adapter.



U.S. ARMY DEFENSE AMMUNITION CENTER AND SCHOOL - SAVANNA, IL

Photo No. AO317-SPN-91-173-1928. This photo shows the bottom surface of the bottom pallet adapter. The adapter pin was sheared off by the pallet during the incline-impact test.

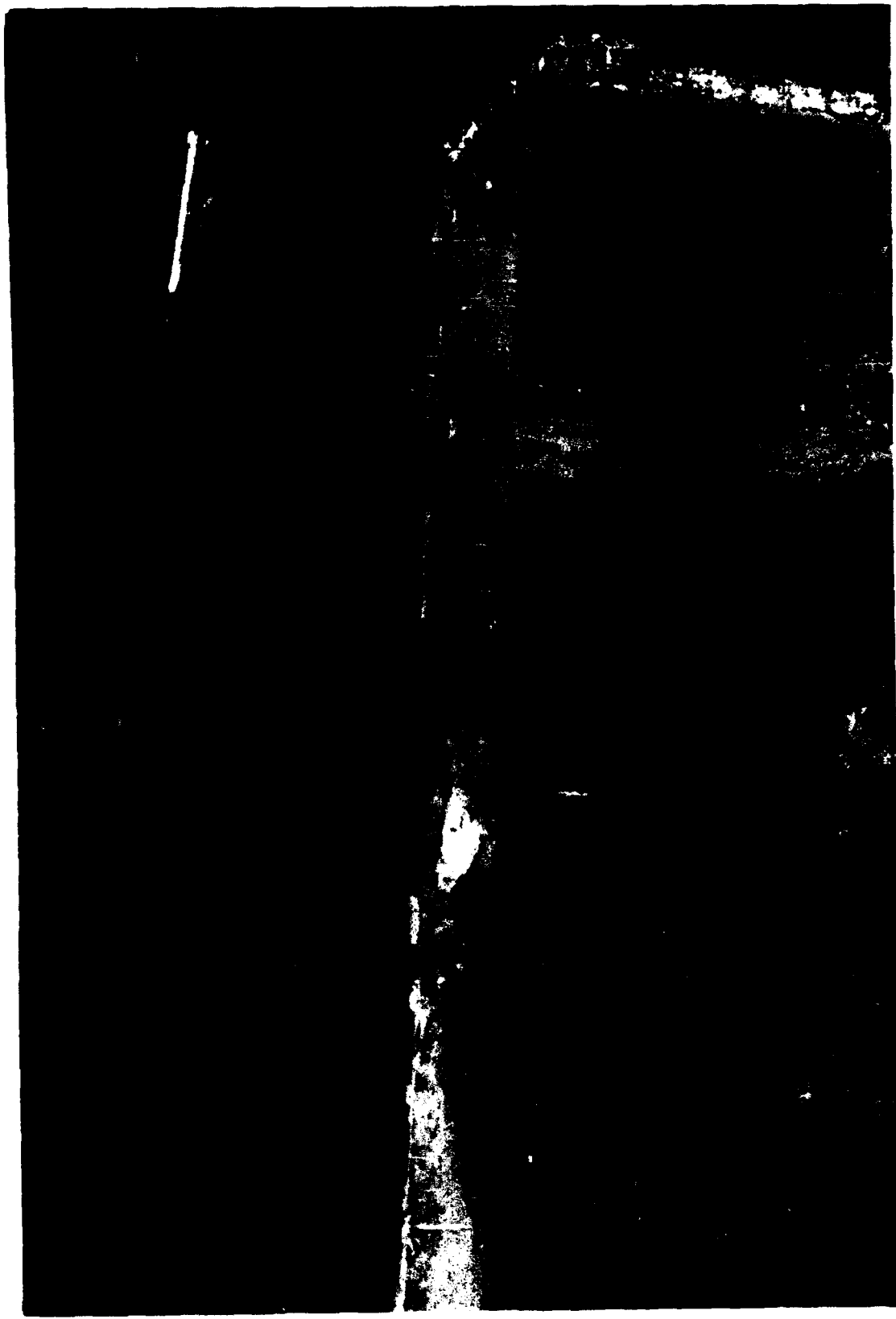

U.S. ARMY DEFENSE AMMUNITION CENTER AND SCHOOL - SAVANNA, IL

Photo No. AO317-SPN-91-173-1930. This photo shows deformation of the pallet sustained around the hole in the pallet deck where the bottom adapter pins are inserted.

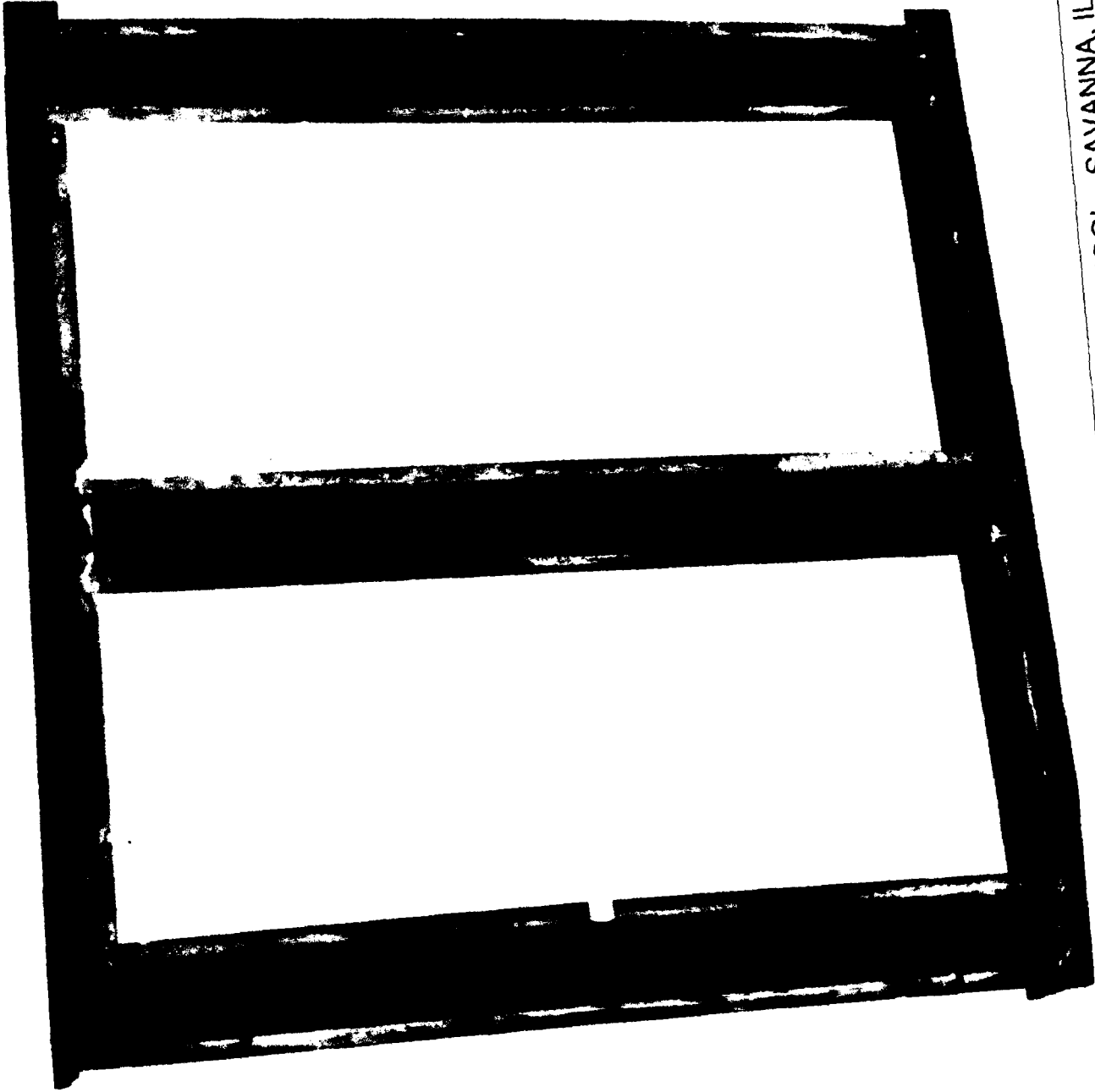

U.S. ARMY DEFENSE AMMUNITION CENTER AND SCHOOL - SAVANNA, IL

Photo No. AO317-SPN-90-173-2202. This photo shows the bottom surface of one of the bottom pallet adapters. Three of the four adapter pins were sheared off and one was bent during the incline-impact test.

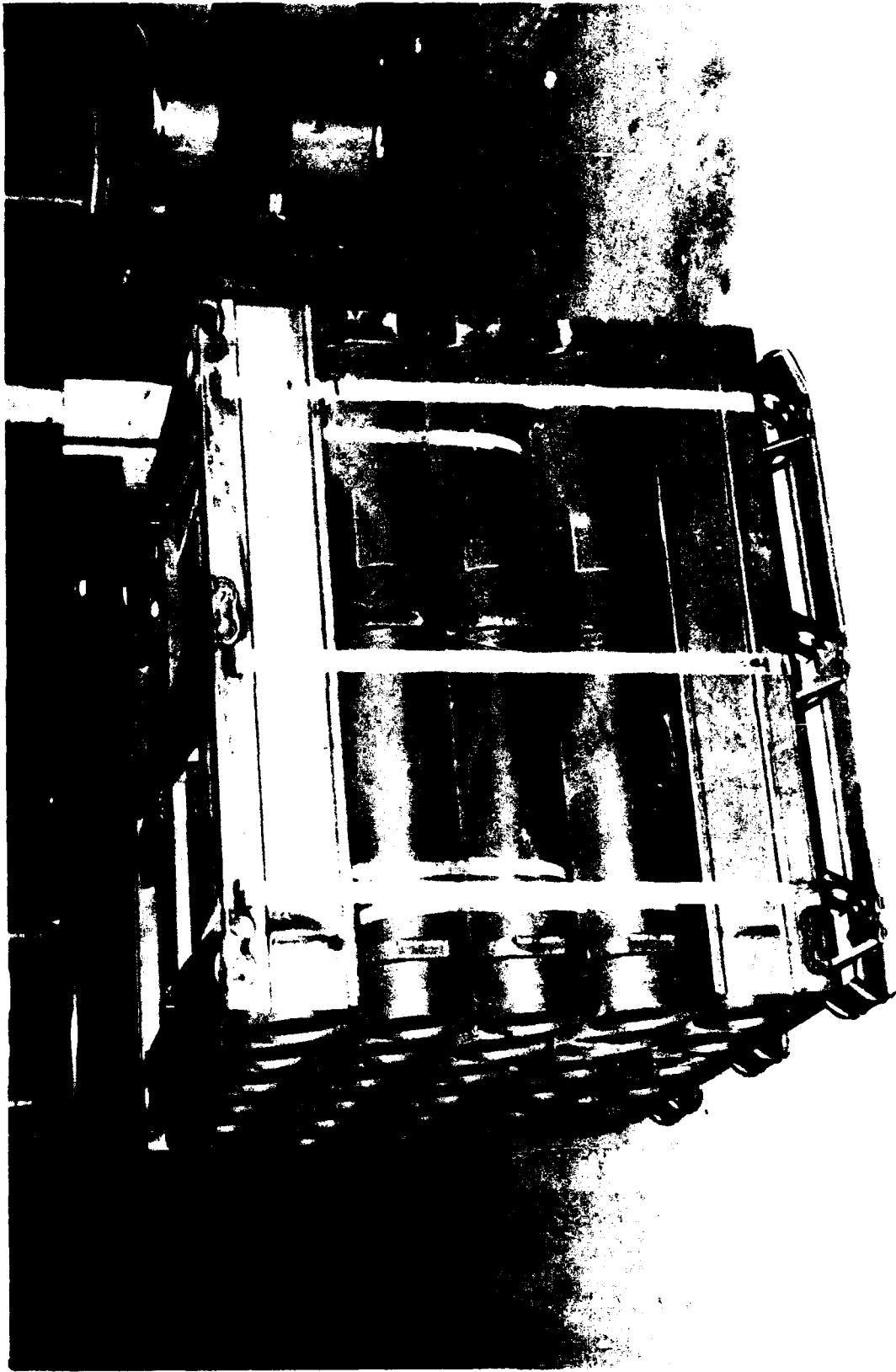

U.S. ARMY DEFENSE AMMUNITION CENTER AND SCHOOL - SAVANNA, IL

Photo No. AO317-SPN-90-173-2207. This photo shows the overall assembly of one of the second FAT samples. This pallet was not painted, in order to save time.



	U.S. ARMY DEFENSE AMMUNITION CENTER AND SCHOOL - SAVANNA, IL	
--	---	--

Photo No. AO317-SPN-90-173-2213. This photo shows the degree of bending that the adapter pins sustained during the second FAT. These pins, which passed the incline-impact test, utilized 1018 grade steel. The pins that sheared off during the first FAT utilized 12L14 grade steel.

PART 9

DRAWINGS

DATE	DESCRIPTION	DATE
90-10-04	PRODUCT BASELINE	90-10-04
ERR MOD 2063		

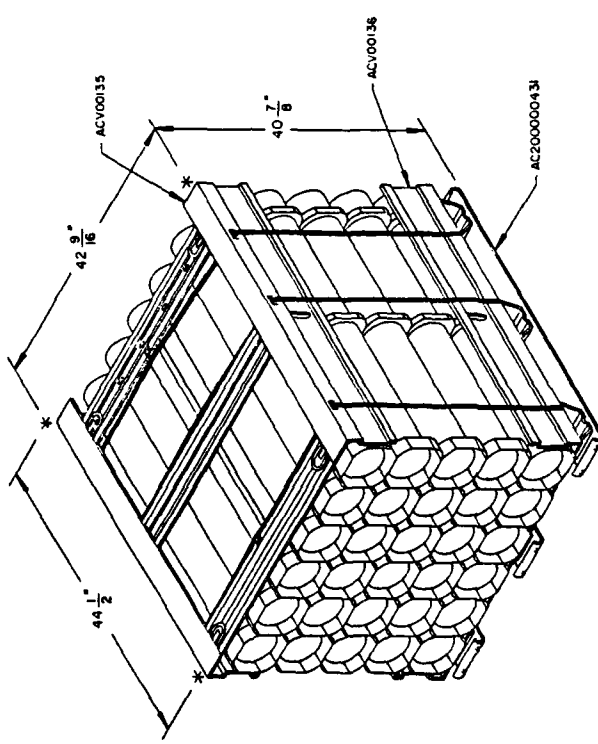

COMBINATION OF ADOPTED ITEMS	PART NO.
PALLET - STANDARD SIZE 44" X 40" SHEET METAL	AC200000431
TOP ASSEMBLY - PALLET ADAPTER, PAL17 CONTAINER	ACV000135
BOTTOM ASSEMBLY - PALLET ADAPTER, PAL17 CONTAINER	ACV000136

DESIGN ACTIVITY	U.S. ARMY CORPORATION AND CHEMICAL CENTER DURHAM, NORTH CAROLINA 27709-5000
DATE	90-10-04
DESIGNER	DREIER
DATE	90-10-04
SCALE	D
SCALE NUMBER	28620
UNIT WT	ACV000134
SHEET	1 OF 1

UNLESS OTHERWISE NOTED
DIMENSIONS ARE IN INCHES
DIMENSIONS IN PARENTHESES ARE IN MILLIMETERS
FRACTIONS ON
DIMENSIONS
DECIMALS
INCHES
MATERIAL

COMBINATION OF ADOPTED ITEMS,
PALLET & PALLET ADAPTER,
UTILIZATION OF PAL17 CONTAINER

APPROVED: *[Signature]*
DATE: 90-10-04

REV	DESCRIPTION	DATE	APPROVED
A	1. REPRAY DETAIL 2. ADD LENGTHS TO WELD CALLOUTS 3. CHANGE DIMENSIONS 4. REPRAY TOLERANCES 5. REPRAY TOLERANCES AND R-R 6. ADDED NOTES AND CHANGED WELDS 7. REPRAY TOLERANCES AND TOLERANCES. 8. REPRAY ON CAD		JMG 02/15/08

- NOTES:
- SPEC MIL-K-2550 AMERICAN WELDING SOCIETY STD. A 2 4-40 ANSI Y14.3-82 APPLY
 - PROTECTIVE FINISH SHALL BE IN ACCORDANCE WITH DWG AC20000423.
 - COLOR SHALL BE GREEN NO. 383 PER MIL-C-46169 (FED STD 595 NO. 34095).
 - PAINTING SHALL BE IN ACCORDANCE WITH DWG AC20000423.
 - COLOR SHALL BE WHITE NO. 37875 1/4 INCH HIGH LETTERS.
 - WEIGHT CONSTRUCTION SPEC MIL-S-120-7281 APPLIES.
 - WELDING SHALL BE IN ACCORDANCE WITH MIL-STD-883C AND MIL-STD-883D.
 - WELDS SHALL BE FULL PENETRATION WELDS.
 - WELDS SHALL BE FULL WELDED UNLESS OTHERWISE SPECIFIED BY 10 MORE THAN 1500 LBS UNIFORMLY APPLIED TO THE TOP SURFACE OF THE DECK.
 - THIS DIMENSION IS TO BE CHECKED AT THE INSPECTION POINTS (IP) DEFINED IN THE TOP VIEW.

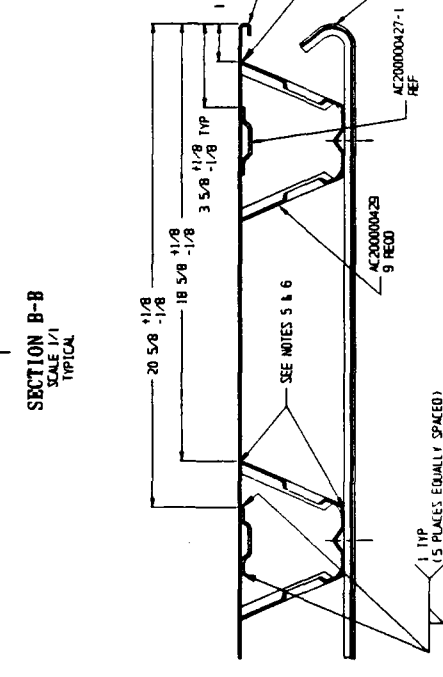
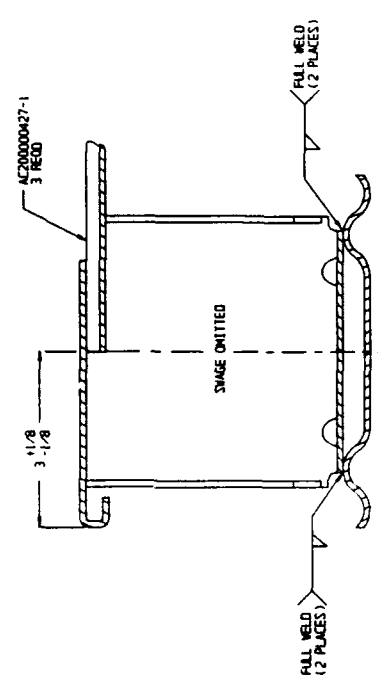
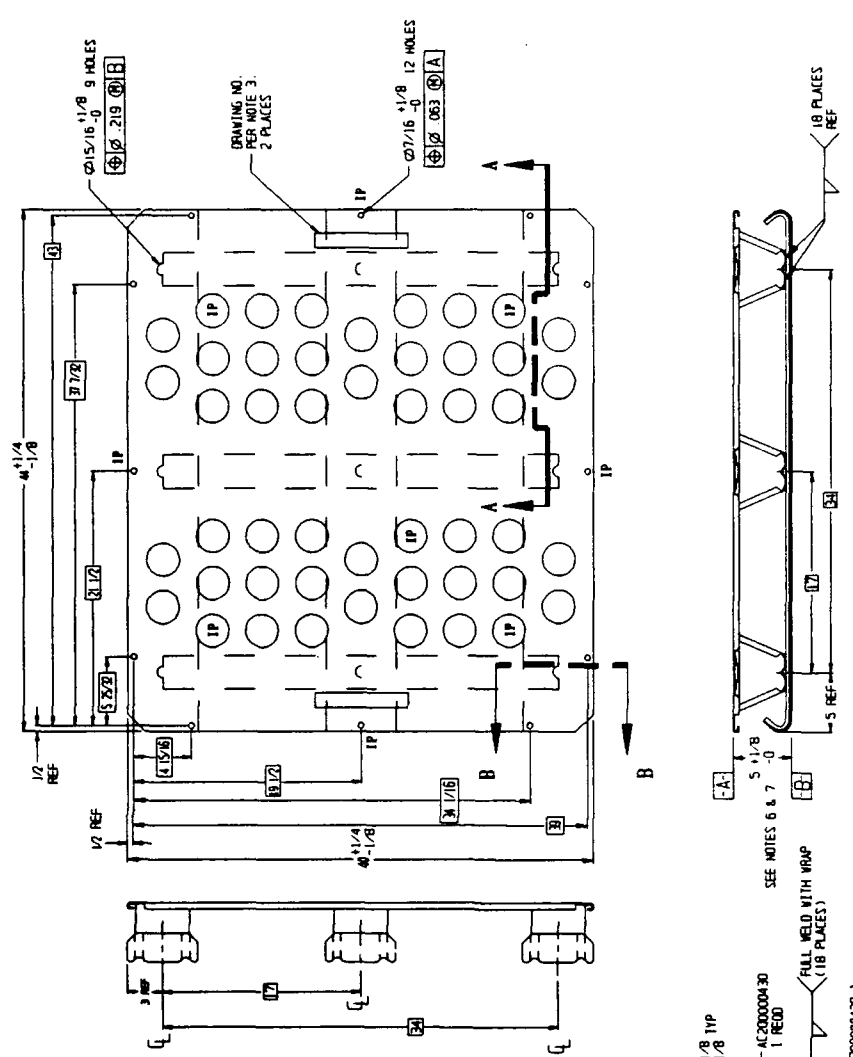

REV	DESCRIPTION	DATE	APPROVED
A	1. REPRAY DETAIL 2. ADD LENGTHS TO WELD CALLOUTS 3. CHANGE DIMENSIONS 4. REPRAY TOLERANCES 5. REPRAY TOLERANCES AND R-R 6. ADDED NOTES AND CHANGED WELDS 7. REPRAY TOLERANCES AND TOLERANCES. 8. REPRAY ON CAD		JMG 02/15/08

DESIGN ACTIVITY

DESIGNER: JMG
CHECKER: JMG
DATE: 02/15/08

US MAR 1959
MATERIAL: 6061-T6 ALUMINUM
FINISH: ANODIZED
TOLERANCES: UNLESS OTHERWISE SPECIFIED

WELDS: FULL PENETRATION WELDS
WELDING: MIL-STD-883C AND MIL-STD-883D

INSPECTION: MIL-STD-883C AND MIL-STD-883D

SCALE: 1/4

PROJECT: AC20000431

SHEET: 28620

APPLICATION:

PALLET - STANDARD SIZE 44 X 40
SHEET METAL

SCALE: 1/4

SHEET: 28620

PROJECT: AC20000431

DESIGNER: JMG

CHECKER: JMG

DATE: 02/15/08

REVISION		DATE	APPROVED
1	PRODUCT BASELINE EPR MDC2063	90-10-04	90-10-04

- NOTES:
- SPEC MIL-A-2850, AMERICAN WELDING SOCIETY STD A 2.4-79 AND ASTM V1A S4-82 APPLY.
 - PROTECTIVE FINISH SHALL BE IN ACCORDANCE WITH DNG AC200000423.
 - COLOR SHALL BE GREEN NO. 383 PER MIL-C-46108 (FED STD 595 NO. 34086).
 - MARKING SHALL BE IN ACCORDANCE WITH DNG AC200000423.
 - COLOR SHALL BE WHITE NO. 37875 1/4 INCH HIGH LETTERS.
 - WELDMENT CONSTRUCTION SPEC MIL-STD-1281 APPLIES.
 - DIMENSIONS OF THE RETAINER RING MAY BE VARIED TO INSURE THE RING'S POSITION WHEN LIFTED VERTICALLY SHALL BE BETWEEN 75 AND 85 DEGREES WITH THE HORIZONTAL. THIS DIMENSION ASSURES THAT THE RING SHALL BE SELF NESTING WHEN NOT IN USE.
 - CHAMFERED CORNER SHALL NOT BE WELDED IN ORDER TO ALLOW ADDITIONAL DRAIN HOLE.
 - ALTERNATE ALIGNING LUG (PART NO. AC200000453-3) MAY BE USED INSTEAD OF PART NO. AC200000453-1.
 - MINOR DEFORMATIONS TO THE SIDE RAIL MAY BE ACCEPTABLE AFTER THE RINGS ARE PULL-TESTED TO THE 2,500 POUND LOAD TEST.

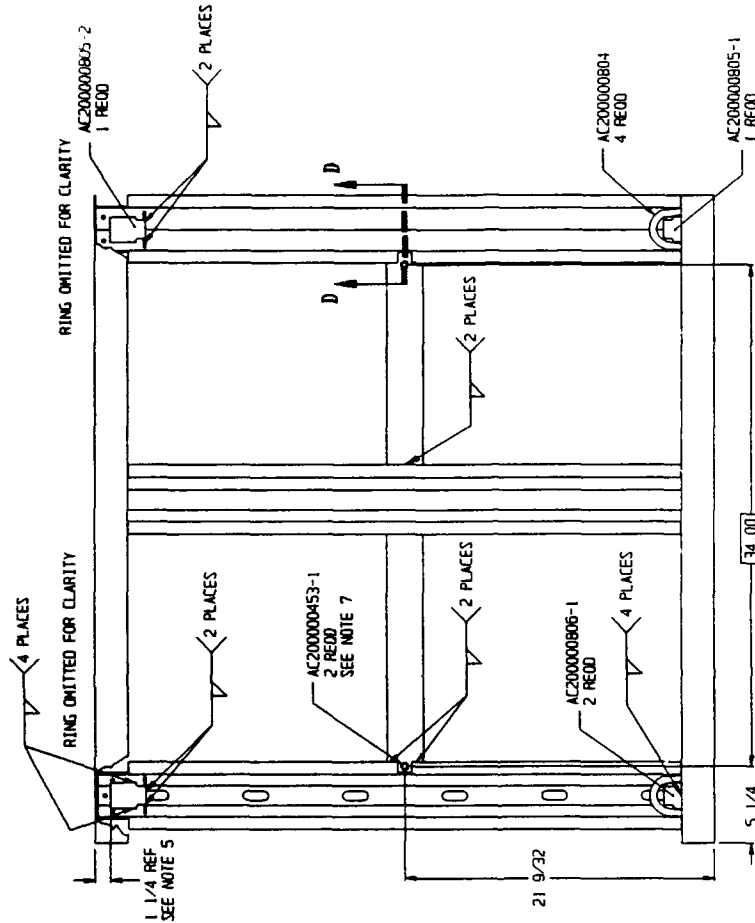

VIEW A-A

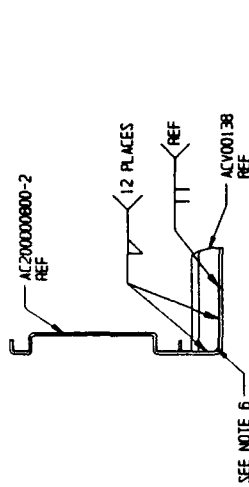

VIEW B-B
SCALE 1/2

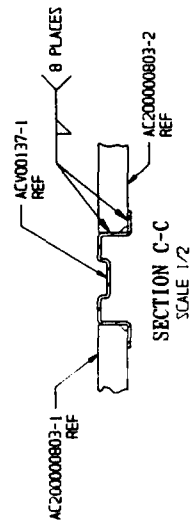

SECTION C-C
SCALE 1/2

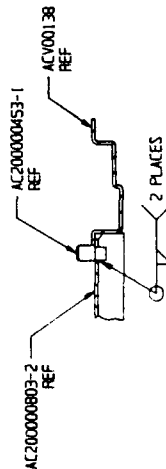

SECTION D-D
SCALE 1/2

DESIGN ACTIVITY		U.S. Army ARMED SERVICES CENTER DISTRIBUTION CENTER BETHLEHEM, PENNSYLVANIA 18015-5061	
DATE	90-10-04	DESIGNER	DREIER
BY	KNO SMS	CHECKED	
APPROVED		DATE	
TITLE		SCALE	UNIT
TOP ASSEMBLY - PALLET ADAPTER PALLET CONTAINER		D	1/4
PART NUMBER		ACV00135	
APPLICATION			
SHEET 2 OF 2			

APPENDIX 45

UNITIZATION PROCEDURES FOR AMMUNITION AND COMPONENTS PACKED IN CYLINDRICAL METAL OR PLASTIC CONTAINERS ON 4-WAY ENTRY METAL PALLET

CARTRIDGE, 105MM, PACKED 1 PER PA117
CYLINDRICAL METAL CONTAINER, UNITIZED 30
PER 44" X 40" PALLET; APPROX CONTAINER
SIZE 44-1/2" L X 6-7/8" W X 6-7/8" H

NOTICE: THIS APPENDIX CANNOT STAND ALONE BUT MUST BE USED IN CONJUNCTION WITH
THE BASIC UNITIZATION PROCEDURES DRAWING 19-48-4231-20PM1006.

U.S. ARMY MATERIEL COMMAND DRAWING			
APPROVED, U.S. ARMY ARMAMENT, MUNITIONS AND CHEMICAL COMMAND <i>David G. Piskovick</i> <i>Capt David M. Brown</i> <small>TMCAR-ESK AMSMC-TMD</small>	DRAFTSMAN	TECHNICIAN	ENGINEER
	S. VON THUN		L. FIEFFER
APPROVED BY ORDER OF COMMANDING GENERAL, U.S. ARMY MATERIEL COMMAND <i>Allen L. Byrd</i> U.S. ARMY DEFENSE AMMUNITION CENTER AND SCHOOL	EVALUATION DIVISION	STORAGE & OUTLOADING DIVISION	LOGISTICS ENGINEERING OFFICE
	<i>J. W. Smith</i>	<i>W. Smith</i>	<i>W. F. Ernst</i>
	DECEMBER 1990		
	CLASS	DIVISION	DRAWING
	19	48	4231/ 45
			FILE
			20PM 1006

DO NOT SCALE

PALLET UNIT DATA						
ITEMS INCLUDED		HAZARD CLASSIFICATION ●				WEIGHT
NSN	OOOIC	DOT CLASS	CG CLASS	QD CLASS	COMP GROUP	(LBS)
1315-UNASSIGNED	C445	_____	TO BE DETERMINED	_____	_____	1,987
UNASSIGNED	C449	_____	TO BE DETERMINED	_____	_____	2,197
UNASSIGNED	C473	_____	TO BE DETERMINED	_____	_____	1,987
UNASSIGNED	C479	_____	TO BE DETERMINED	_____	_____	2,077
01-245-4019	C524	B	II-B	(08)1.2	C	1,919
UNASSIGNED	C540	_____	TO BE DETERMINED	_____	_____	2,077
UNASSIGNED	C542	_____	TO BE DETERMINED	_____	_____	2,197
01-324-6633	C543	B	II-B	(08)1.2	C	1,919
01-320-4190	C544	_____	TO BE DETERMINED	_____	_____	2,257
01-250-2857	C546	_____	TO BE DETERMINED	_____	_____	2,257

● HAZARD CLASSIFICATION DATA CONTAINED IN THE ABOVE CHART IS FOR GUIDANCE AND INFORMATIONAL PURPOSES ONLY. VERIFICATION OF THE SPECIFIED DATA SHOULD BE MADE BY CONSULTING THE MOST RECENT JOINT HAZARD CLASSIFICATION SYSTEM LISTING OR OTHER APPROVED LISTING(S).

GENERAL NOTES

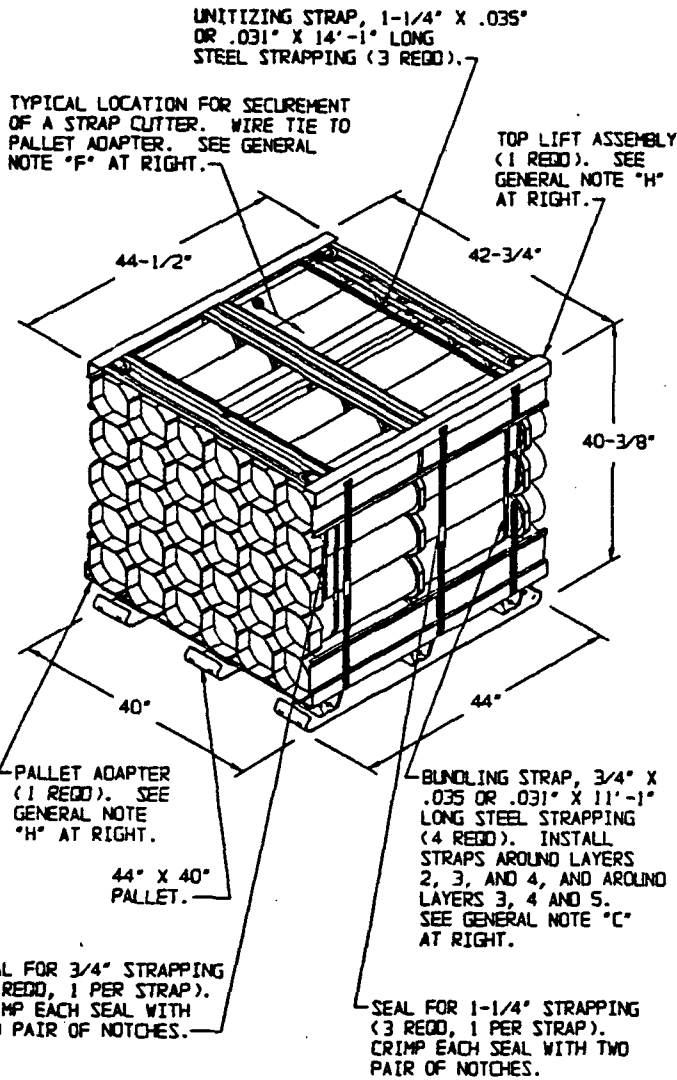

- A. THIS APPENDIX CANNOT STAND ALONE BUT MUST BE USED IN CONJUNCTION WITH THE BASIC UNITIZATION PROCEDURES DRAWING 19-48-4231-20PM1006. TO PRODUCE AN APPROVED UNIT LOAD, ALL PERTINENT PROCEDURES, SPECIFICATIONS AND CRITERIA SET FORTH WITHIN THE BASIC DRAWING WILL APPLY TO THE PROCEDURES DELINEATED IN THIS APPENDIX. ANY EXCEPTIONS TO THE BASIC PROCEDURES ARE SPECIFIED IN THIS APPENDIX.
- B. DIMENSIONS, CUBE AND WEIGHT OF A PALLET UNIT WILL VARY SLIGHTLY DEPENDING UPON THE ACTUAL DIMENSIONS OF THE BOXES AND THE WEIGHT OF THE SPECIFIC ITEM BEING UNITIZED.
- C. BUNDLING STRAPS MUST BE TENSIONED AND SEALED PRIOR TO THE APPLICATION OF THE UNITIZING STRAPS. INSTALL BUNDLING STRAPS AS CLOSE TO THE OUTER CONTAINER BELLS OR RINGS AS POSSIBLE, TO AVOID DAMAGE TO THE CONTAINERS.
- D. ALTHOUGH THE CONTAINERS DEPICTED IN THE UNIT LOAD AT LEFT ARE CONSTRUCTED WITH INTERLOCKING DEVICES, THE INTERLOCKS WILL NOT FUNCTION PROPERLY UNLESS THE CONTAINERS ARE POSITIONED SO THAT THE "PINS" OF THE INTERLOCKS ARE FACING UPWARD. THIS ORIENTATION WILL AID IN THE PREVENTION OF CONTAINER MOVEMENT, BOTH LATERALLY AND LONGITUDINALLY, DURING SHIPMENT OF THE UNIT LOAD.
- E. THE FOLLOWING AMC DRAWINGS ARE APPLICABLE FOR UNLOADING AND STORAGE OF THE ITEMS COVERED BY THIS APPENDIX.
 - CARLOADING - - - - 19-48-4246/45-SPM1011
 - TRUCKLOADING - - - - 19-48-4247/45-11PM1011
 - STORAGE - - - - - 19-48-4250-1-2-3-4-14-22PM1005
 - COMMERCIAL CONTAINER - - - - - 19-48-4244/45-1SPM1007
 - MILVAN - - - - - 19-48-4245/45-1SPM1008
- F. FOR METHOD OF SECURING A STRAP CUTTER TO THE PALLET UNIT, SEE AMC DRAWING 19-48-4127-20P1000.
- G. IF ITEMS COVERED HEREIN ARE UNITIZED PRIOR TO ISSUANCE OF THIS APPENDIX, THE CONTAINERS NEED NOT BE REUNITIZED SOLELY TO CONFORM TO THIS APPENDIX.
- H. FOR DETAILS OF THE PALLET ADAPTER AND TOP LIFT ASSEMBLY, SEE MILITARY SPECIFICATION MIL-A-70754.
- J. THE UNITIZATION PROCEDURES DEPICTED HEREIN MAY ALSO BE USED FOR UNITIZING 105MM CARTRIDGES WHEN IDENTIFIED BY DIFFERENT NATIONAL STOCK NUMBERS (NSN) THAN WHAT IS SHOWN ON PAGE 2, PROVIDED THE CONTAINER PACK DOES NOT VARY FROM WHAT IS DELINEATED HEREIN. THE EXPLOSIVE CLASSIFICATION OF OTHER ITEMS MAY BE DIFFERENT THAN WHAT IS SHOWN.
- K. EMPTY OR REJECT PA117 CONTAINERS WILL BE USED AS FILLER CONTAINERS AS NECESSARY. FILLER CONTAINERS MUST BE INSTALLED IN THE MIDDLE OF THE TOP LAYER(S) OF CONTAINERS. IF SIX FULL CONTAINERS ARE TO BE OMITTED, ONE FULL LAYER OF CONTAINERS WILL BE OMITTED. WHEN (EMPTY) FILLER CONTAINERS ARE USED IN PLACE OF OMITTED CONTAINERS TO COMPLETE A LAYER ON A PALLET, THEY WILL BE MARKED AS SPECIFIED WITHIN MIL-STD-129.

PALLET UNIT

SEE GENERAL NOTE "B" AT RIGHT.

30 CONTAINERS OF 105MM CARTRIDGES (1 PER CONTAINER) @ 68 LBS	-----	2,040 LBS (APPROX)
QUINAGE	-----	112 LBS
PALLET	-----	105 LBS
TOTAL WEIGHT	-----	2,257 LBS (APPROX)
CUBE	-----	44.45 CU FT (APPROX)

BILL OF MATERIAL

METAL PALLET, 44" X 40"	-----	1 REQ	-----	105 LBS
PALLET ADAPTER	-----	1 REQ	-----	48 LBS
TOP LIFT ASSEMBLY	-----	1 REQ	-----	54 LBS
STEEL STRAPPING, 3/4"	44.33'	REQ	-----	3.17 LBS
STEEL STRAPPING, 1-1/4"	42.25'	REQ	-----	6.04 LBS
SEAL FOR 3/4" STRAPPING	-----	4 REQ	-----	NIL
SEAL FOR 1-1/4" STRAPPING	-----	3 REQ	-----	NIL

