

AD-A260 677

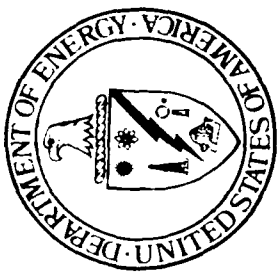

DTIC
ELECTE
FEB 12 1993
S E D

Facsimile Report



Reproduced by
**UNITED STATES
DEPARTMENT OF ENERGY**

Office of Scientific and Technical Information
Post Office Box 62
Oak Ridge, Tennessee 37831

DISTRIBUTION STATEMENT
Approved for public release
Distribution Unlimited

42:379 DOE/STI

93-02572

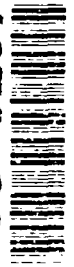

93 2 10 098

LEGIBILITY NOTICE

A major purpose of the Technical Information Center is to provide the broadest dissemination possible of information contained in DOE's Research and Development Reports to business, industry, the academic community, and federal, state and local governments.

Although a small portion of this report is not reproducible, it is being made available to expedite the availability of information on the research discussed herein.

DISCLAIMER NOTICE

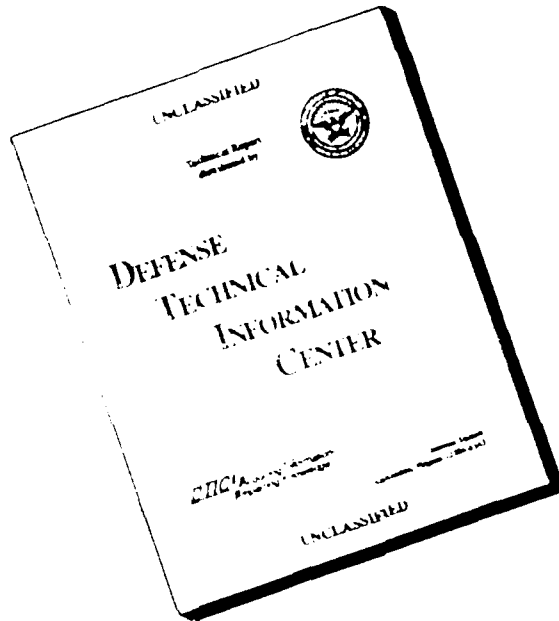

THIS DOCUMENT IS BEST
QUALITY AVAILABLE. THE COPY
FURNISHED TO DTIC CONTAINED
A SIGNIFICANT NUMBER OF
PAGES WHICH DO NOT
REPRODUCE LEGIBLY.

Weapons Engineering Division
Materials Fabrication Division

UCRL-JC--104493
DE90 015192

IGES EFFICIENCY EVALUATION

 Lawrence Livermore
National Laboratory

Accession For	
NTIS CRA&I	<input checked="" type="checkbox"/>
DTIC TAB	<input type="checkbox"/>
Unannounced	<input type="checkbox"/>
Justification	
By	
Distribution/	
Availability Codes	
Dist	Avail and/or Special
A-1	23

June 12, 1990

M. Christensen, ASD
J. Farrell, MFD
S. Green, ASD

DISCLAIMER

This report was prepared as an account of work sponsored by an agency of the United States Government. Neither the United States Government nor any agency thereof, nor any of their employees, makes any warranty, express or implied, or assumes any legal liability or responsibility for the accuracy, completeness, or usefulness of any information, apparatus, product, or process disclosed, or represents that its use would not infringe privately owned rights. Reference herein to any specific commercial product, process, or service by trade name, trademark, manufacturer, or otherwise does not necessarily constitute or imply its endorsement, recommendation, or favoring by the United States Government or any agency thereof. The views and opinions of authors expressed herein do not necessarily state or reflect those of the United States Government or any agency thereof.

FORM 3

TABLE OF CONTENTS

<u>SECTION</u>	<u>PAGE</u>
1.0 INTRODUCTION	1
2.0 WED ACTIVITIES	2
2.1 DRAWING CREATION TIME SUMMARY	3
2.2 DATABASE CHECKING AND PREPPING PROCEDURES	4
3.0 DATA TRANSMISSION SUMMARY	5
4.0 MFD ACTIVITIES	6
4.1 NC AND INSPECTION PROGRAMMING TIME SUMMARY	6
4.2 MFD NC AND INSPECTION PROGRAMMING CONCLUSIONS	7
4.3 WED OBSERVATION OF MFD ACTIVITIES	8
4.3.1 ACCURACY	8
4.3.2 DATABASE CHECKING	8
4.3.3 CONTOUR DEFINITION	8
5.0 INTRODUCTION TO DATA EXCHANGE FORMATS	9
5.1 HPGL FILES	9
5.2 IGES FILES	9
5.3 DATA EXCHANGE FORMAT EVALUATION	10
5.3.1 PART 1 - MOCK CHOCK	10
5.3.1.1 CASE 1 - UNCHECKED IGES FILE	10
5.3.1.2 CASE 2 - CHECKED IGES FILE	11
5.3.1.3 CASE 3 - HPGL FILE	11
5.3.2 PART 2 - BELLYBAND	11
5.3.2.1 CASE 1 - UNCHECKED IGES FILE	11
5.3.2.2 CASE 2 - CHECKED IGES FILE	12
5.3.2.3 CASE 3 - HPGL FILE	12
5.4 DATA EXCHANGE SUMMARY	12
6.0 RECOMMENDATIONS	13
7.0 CONCLUSIONS	14
APPENDIX	
A. IGES MAPPING TABLE	
B. BELLYBAND HPGL SHEETS 1 AND 2	
C. BELLYBAND UNCHECKED IGES SHEETS 1 AND 2	
D. BELLYBAND CHECKED IGES SHEETS 1 AND 2	

Executive Summary

This report describes the IGES Efficiency Study, a joint effort of Weapons Engineering Division (WED) and Materials Fabrication Division (MFD). The goal of the study was to quantify the impact of accurate geometry in design, manufacturing and inspection of mechanical parts.

Two parts were designed, manufactured and inspected; a hemispherical and non-hemispherical part. Each part was designed in WED using CAD. Then three sources of numerical control (NC) tool paths and inspection probe paths were received in MFD: (1) an unchecked CAD/IGES database, (2) a guaranteed CAD/IGES database, (3) an electronic Hewlett-Packard Graphics Language (HPGL) file representing the CAD drawing.

These are the Evaluation Team recommendations:

- 1) WED should release HPGL and unchecked IGES files to MFD.
- 2) MFD should check the geometry before manufacturing.
- 3) WED should transfer IGES files to MFD generated from a double precision database.
- 4) Until recommendation number three is implemented, MFD should create splines from data in the contour tables, and not the contour data file.
- 5) MFD should remove redundant effort on the part of the NC and inspection programmers.
- 6) Both WED and MFD should keep their IGES processors updated to the current IGES version available from their respective CAD software vendors.

Acknowledgements

Many people contributed to this study. It was initiated by Fumi Shimamoto, past CIM Manager in MFD, and Derek Wapman, CAE Group Leader in WED. The cooperation of the W89 program, who supplied the parts, is greatly appreciated, along with MFD NC programming and inspection.

This work was performed under the auspices of the U.S. Department of Energy by Lawrence Livermore National Laboratory under contract No. W-7405-Eng-48.

1.0 Introduction

To maximize the investments in CAD and CAM systems requires the creation and utilization of accurate geometry information during the design, manufacturing and inspection processes. The verification of geometry information creates additional costs to the design divisions. However, accurate geometry potentially reduces the direct costs of the manufacturing cycle. This study was designed to quantify those costs and to identify other intangible or second-order benefits in both design and manufacturing.

Each part was designed and used to generate NC and inspection probe paths.

Case 1

An unchecked IGES file was generated from a CAD drawing. The unchecked IGES file and HPGL file were sent via the electronic connection between WED and MFD. MFD checked the geometry and then generated the NC tool paths and inspection probe paths using these files.

Case 2

The CAD database was checked and the geometry "guaranteed" by WED. The checked IGES file was generated from the CAD drawing. The checked IGES file and the HPGL file were sent via the electronic connection to MFD. MFD generated the NC tool paths and inspection probe paths using these files. MFD did not recheck the IGES file.

Case 3

The CAD drawing was used to generate a HPGL file which was sent to MFD via the electronic connection. MFD generated the NC tool paths and the inspection probe paths using a paper drawing printed from the HPGL file.

2.0 WED ACTIVITIES

The two parts selected for the IGES efficiency evaluation are "typical" parts of WED Drafting. This is a study evaluating the exchange of database information as opposed to the file contents. Therefore, detailed techniques of drawing creation are not covered. To reduce the time to create a drawing, drafters occasionally modify released drawings. Time differences between creating a drawing from scratch versus modifying existing drawings is dependent on the complexity of the part being defined - typically twice as long.

The parts were designed using Computervision (CV) CADDStation CADD54X v3.0, in the unchecked database mode. The unchecked database implies that the geometry may be incorrect and must not be used for manufacturing. The unchecked database complies with WED Drafting standards of layering convention & annotation. The drafter creates a plot file when WED standards are met and the visual representation of the part is correct. The lead designer manually checks the plot content for visual correctness. The interaction between drafter and designer continues until the designer approves the visually correct plot file.

An accurate (checked) database is a superset of an unchecked database. The geometry is checked for accuracy and could be used for manufacturing. The checking of an accurate database is interactive and time expensive, but routines have been written to reduce the time and possible errors. To create an accurate database requires an experienced detail drafter because more intelligence is included in the database. The checked database follows the same sign-off procedures as an unchecked database. Not only does the accurate database meet WED drafting standards, but also CIM standards (i.e. gap check, duplicate entity, associative dimensions, etc...).

When the drawing is released, the part database is archived. Routines to check the part for WED drafting compliance is accomplished interactively. If any changes need to be made, the lead designer is notified where the corrective action is determined. The drawing could be modified on-line or returned to the drafter where the process starts over. The part databases are stored on an IBM 4361 main-frame via CV's Product Data Manager (PDM). The database is marked as a released part and locked to prevent any further modifications. Revisions are maintained and stored as new parts with identical part name but different version number.

Plot files, including IGES files, are stored on a VAX 8530 via DEC's Engineering Data Control System (EDCS) after any file format modifications are completed.

Releases to manufacturing plants are extracted from EDCS

2.1 DRAWING CREATION TIME SUMMARY

Table 1 shows the times measured for each part. Two drawings were created for the Mock Chock and are identified separately. The time for the contour file received from physics is outside the scope of this study, but is listed to distinguish the two parts.

Table 1

<u>PART</u>	<u>ACTION</u>	<u>TIME</u>
Part 1		
Mock Chock FWD (AAA89-113801-00)		
	Contour from Physics	?
	Create part database	2.00 hours
	Designer check (visual)	1.00 hour *
	Accurate Database	1.50 hour
	Prepping (HPGL, IGES, EBR)	0.50 hour

	Total	5.00 hours
Part 1		
Mock Chock AFT (AAA89-113800-00)		
	Contour from Physics	?
	Create part database	2.00 hours
	Designer check (visual)	1.00 hour *
	Accurate Database	1.00 hour
	Prepping (HPGL, IGES, EBR)	0.50 hour

	Total	4.50 hours
Part 2		
BellyBand (AAA89-113592-00)		
	Create part database	4.00 hours
	Designer check (visual)	1.00 hour *
	Accurate Database	5.00 hours
	Prepping (HPGL, IGES, EBR)	0.25 hour

	Total	10.25 hours

* time for each drawing sheet

2.2 DATABASE CHECKING AND PREPPING PROCEDURES

Following is a list of actions taken within the checking and prepping of a database. Every drawing is verified to meet WED drafting standards via the unchecked database routine. An accurate database is verified to meet WED drafting standards and CIM standards. The actions are listed in chronological order.

Unchecked Database [required for all files]

1. Clean-up & maintenance of database (check/pack/sort)
2. Part Parameter check
 - Drawing names follow WED standard
 - Part units (model units = draw units)
 - View names follow WED standard
 - Single precision database mode
3. WED Annotation convention (automated routine)
4. WED layering convention (interactive routine)

Creation of plot files [required for all plot files]

1. Create plot files (automated routine)
2. Build NWC headers (automated routine)

Accurate Database [IGES only]

1. Gap closure check (automated routine)
2. Duplicate entity check (automated routine)
3. Point comparison check for contours (automated routine)
4. Associative dimension check (automated routine)

Prepping [IGES only]

1. Build NWC headers (automated routine)
2. Delete N-Fig (drawing format)
3. Create drawing format
4. Insert Disclaimer (unchecked only)
5. Create IGES v2.0 files

3.0 DATA TRANSMISSION SUMMARY

MFD receives WED engineering data via two channels, (1) via the ERC, and (2) via the WED - MFD electronic link. Data received in MFD via the ERC is a hand-delivered packet containing paper engineering drawings and a job order. Data received in MFD via the electronic link is a set of electronic files; a HPGL file representing the engineering drawing, an ASCII contour definition file, and a faxed job order. Section 7.0 describes in detail the formats of the HPGL and IGES files transferred for this study.

Empirical data collected by MFD indicates WED engineering data typically spends four to five days in the ERC before being released to MFD. However, MFD will receive data transferred electronically within the hour following its release from WED. The fact that MFD can receive this data sooner means manufacturing can begin sooner, resulting in WED receiving their part(s) sooner.

4.0 MFD ACTIVITIES

The parts were programmed in MFD using the McDonnell Douglas Unigraphics (UG) CAD/CAM software. The activities of the NC and inspection programmer prior to tool and probe path generation are identical. The only difference will be how the programmer describes the tool or probe path to the manufacturing system. Typically, the programmer will follow these steps:

- 1) Open new Unigraphics part file
- 2) Create geometry necessary to machine/inspect particular features of the part
- 3) Import contour data (if necessary)
- 4) Dimension geometry to verify accuracy and conformance to the engineering drawing
- 5) Copy geometry to different layers per NC and inspection programming layering conventions
- 6) Describe tool and tool path to the Unigraphics machining module

OR

- 6) Run probe path generation program

4.1 NC AND INSPECTION PROGRAMMING TIME SUMMARY

Table 2 shows the amount of time spent on each test case. Note that these values apply only to these test cases, and should not be used as a reference for similar parts manufactured in the future.

Table 2

Part 1 Mock Chock	NC Prog.		Inspection		
	Aft	Fwd	Aft	Fwd	
Case 1	7.0	8.0	5.0	6.0	Unchecked IGES
Case 2	5.0	4.0	2.5	3.0	Checked IGES
Case 3	6.0	4.0	5.0	5.0	Print Only

Part 2 Bellyband	NC Prog.	Inspection	
	Case 1	5.0	
Case 2	3.0	4.0	Checked IGES
Case 3	8.5	4.0	Print Only

The following comments are included to help interpret the values shown in Table 2.

MFD NC and inspection programmers had no experience working with IGES files.

Thus, the times reported for Part 1, Case 1 include time spent learning WED IGES file organization.

There is approximately a 30-50% time savings when a checked IGES file was used instead of an unchecked IGES file. Actual savings are less because the programmers knew exactly what they were to do when use of the IGES file was repeated.

Likewise, programming time for Case 3 is influenced by repeated programming tasks in Case 1 and Case 2. A follow-up interview conducted with the NC and inspection programmer revealed that no matter what case ordering was used, programming time would be influenced from previous cases.

WED observers were on hand during NC and inspection programming for Case 1 Aft. Thus, the reported times for this part includes discussion time among all attendees, both WED and MFD, during which the programmer participated.

Even though Case 2 used a checked IGES file, the numbers still include the programmer having to make minor modifications to geometry prior to tool path generation. These modifications involved the addition of machining geometry and dimensions to ensure engineering drawing conformance.

4.2 MFD NC AND INSPECTION PROGRAMMING CONCLUSIONS

Following are concluding comments discussed with the NC and inspection programmers following the IGES Efficiency Study.

Lack of experience with IGES files made initial programming cumbersome. When the post-processed IGES file was first viewed in Unigraphics, there was no indication of how it was organized. In fact, when first retrieved in Unigraphics, only geometry was visible. Having all entities (geometry, notes, labels, dimensions, etc.) displayed initially would provide valuable information.

Using the IGES file is preferred to creating the geometry from scratch. IGES files are especially useful after learning how they are organized.

It is much easier if MFD checks the database. IGES does not transfer associative dimensions. Thus, dimensioning the geometry would re-establish associative dimensions, and establish an accounting trail detailing the status of the geometry prior to manufacture. If the accounting trail does not exist, any errors in the manufactured part will be difficult to trace to a problem either MFD, WED, their CAD systems, or IGES introduced.

Using an IGES file (checked or unchecked) will never relieve the programmer from having to create or modify geometry. Geometry will always need to be created or modified in order to conform to established programming practices.

4.3 WED OBSERVATION OF MFD ACTIVITIES

WED personnel observed MFD retrieving and using the transferred IGES files. The following sections introduce key problems identified during this evaluation.

4.3.1 ACCURACY

There seems to be some confusion between the accuracy expected by physics and what is actually manufactured. If every stage of the part definition was double precision then accuracy would not be a problem. WED defines the parts in single precision, therefore IGES transfers the points in single precision. A method of achieving higher precision from current electronic file transfers needs to be identified.

4.3.2 DATABASE CHECKING

The checking of geometry must be accomplished before the part is manufactured. The question remains who is responsible for checking the database; the sender or receiver? WED noticed that some of the items checked did not benefit MFD (i.e. gap check on sections of the part that MFD did not use for manufacturing). Other checks were irrelevant (i.e. associative dimensions are not supported by IGES so if MFD wants them they must redefine them). WED Drafting standards did benefit MFD (i.e. layering conventions).

4.3.3 CONTOUR DEFINITION

The points guaranteed by WED drafting to create splines are not used by MFD. Because the accuracy of the contour point geometry is limited by being single precision, MFD re-creates the contours from the contour data file. WED guarantees the spline points in the contour table for "text" visual correctness. However, MFD uses the contour file which is not guaranteed, and thus must be verified visually. Routines should be written to extract the needed information from the contour table.

5.0 INTRODUCTION TO DATA EXCHANGE FORMATS

As discussed in the preceding sections of this report, WED delivered engineering drawings to MFD in three formats: (1) a HPGL file, (2) an unchecked IGES file, and (3) a checked IGES file. This section will detail each mode of delivery and discuss how successfully each format transferred the engineering data used in this test.

5.1 HPGL FILES

To begin, one type of digital data delivered to MFD was a HPGL file. This is the usual format WED uses for digital data delivery. HPGL is a simple vector plot format for HP plotters. It is not the preferred mode of delivery for several reasons. First, it is not a national graphics exchange language, but has become a de facto standard due to its wide usage. Second, its files are very large because it is made up of stroked line segments representing text and geometric shapes. Lastly, HPGL is not preferred because the data drives a plotter at the receiving site, and not a CAD system. However, because of HPGL's simplicity, the sending site is reassured that the receiver can produce a visually equivalent plot of the engineering drawing. The receiving site must transcribe the data from the plotted paper to the CAD system for use.

5.2 IGES FILES

MFD would like to get away from having to re-enter engineering drawing data into its CAD system and looked to IGES for help. IGES is a data format that permits the exchange of a wide number of CAD entities between different CAD systems. Some examples of CAD entities transferred by IGES are: geometry such as circles, lines, and splines; annotation such as notes and dimensions; and structure such as views and drawings. IGES is a national standard published both by the National Institute of Standards and Technology (NIST) and the American National Standards Institute (ANSI). It is widely supported by most CAD vendors, however, not always fully nor well. This is why IGES testing is necessary.

The first step to conduct an IGES test is to prepare a mapping table. A mapping table explores the CAD entities that the transmitting system can pre-process and which of those entities the receiving system can post-process. This table is compiled from the information given by the vendors in their IGES users guides. Only if there is a good correlation between the CAD systems on paper, should one progress to hands-on testing. The mapping for the transfer of data from WED's Computer Vision (CV) CAD system to MFD's Unigraphics (UG) CAD system is displayed in Appendix A. On paper, it appeared that the data transfer would work well; WED and MFD therefore continued with testing.

5.3 DATA EXCHANGE FORMAT EVALUATION

5.3.1 PART 1 - MOCK CHOCK

5.3.1.1 CASE 1 - UNCHECKED IGES FILE

Due to the classification of the Mock Chock, only a brief analysis of the IGES file was conducted. The evaluation revealed that the IGES data transferred well from WED to MFD's CAD system, but an issue arose in its precision. The issue was that the points used to define the contours of the splines were transferred with one less decimal place of precision than desired.

To understand the reason for this loss of precision, one must follow the data path. Originally, the contour data points WED received from physics contained eight digits of information including the decimal place (for example, 1.345678). WED entered these points into its CV CAD system (a 32 bit machine working under single precision) as eight digit numbers including the decimal place (i.e. 1.345678). However, a 32 bit computer can accurately represent only seven digits of information (i.e. 1.34567). Even though the CV CAD system saved the numbers to eight digits, the last digit was not precise. The CV IGES pre-processor, aware of this 32 bit limitation, wrote the IGES data to seven digits including the decimal place (i.e. 1.34567). These seven digit numbers were then read by MFD's UG system (a double precision, 64 bit machine) and saved as seven digits (i.e. 1.34567). In this case, the seven digits of accuracy were still quite good for manufacturing's purposes, but the issue could worsen if WED on occasion delivered larger parts. In that case, data would lose more of its precision.

For example, an actual line was created and transferred via IGES to demonstrate this concept. The CV system was used in default mode (single precision). The line was created and different methods of measurement were used to extract precision accuracy. Table 3 contains this data.

Table 3

Line created with length = 123.456789

CV Command	Original Value	Value After IGES Processing
Verify Entity	123.4568	123.457
Dump Entity	123.4567871	123.4570007
Dimension Entity (default)	123.457	123.457
Dimension Entity (prec. = 6)	123.456785	123.457

Due to the loss of accuracy, it was determined that the spline points in the IGES files would not be used, and that the spline points should be recreated from the contour data file. Even though the spline points from the IGES file were discarded, the remaining geometry such as lines and arcs were used.

5.3.1.2 CASE 2 - CHECKED IGES FILE

Again, detailed analysis was not conducted. A brief evaluation revealed similar results to the unchecked IGES file.

5.3.1.3 CASE 3 - HPGL FILE

The HPGL data transferred well from WED's CAD system to MFD's HP plotter. MFD was able to re-create a visually equivalent engineering drawing.

5.3.2 PART 2 - BELLYBAND

5.3.2.1 CASE 1 - UNCHECKED IGES FILE

The unclassified Bellyband IGES file from the unchecked database was evaluated in depth revealing interesting results. Analysis of the IGES transfer was conducted at the CALS Test Network Lead Test Bed operated by LLNL. The data was parsed, verified, and viewed.

Overall the results were good. The multi-viewed, super-sheeted, engineering drawing maintained its general appearance and functionality. More importantly, the geometry that MFD needed transferred well. On the down side, the graphics MFD displayed contained a few pieces of stray geometry and a fair amount of misplaced annotation. Plots of the engineering drawings both as created by WED and as received by MFD are displayed in Appendices B-D. As the plots show, errors include:

- 1) Centerlines that were angled through the second and fourth quadrants were skewed out of position (see Main View, Section B-B, Section g-g, View h-h, View m-m, and View d-d). These were attributed to CV's pre-processor.
- 2) Multi-lined notes were improperly spaced (see NOTES section on sheet 1). This also was attributed to CV's pre-processor.
- 3) Feature control symbols in the text of dimensions were missing their framing box (see View d-d, View h-h, View K-K, View m-m). This was attributed to both the IGES specification which does not accommodate dimensions with feature control framed text and to the CV pre-processor that does not try to reconstruct the missing annotation.
- 4) Witness lines on linear dimensions that were supposed to be blanked were visible (see Detail 2 and Detail 3). This was attributed to the UG post-processor.
- 5) Model entities that were blanked from view using the Views Visible, Color, Line Font Entity (402 Form 4) were visible in all views (see Section c-c, Section g-g, Section J-J). This was due to UG's inability to post-process this particular form of the views visible entity.
- 6) The radius dimension was incorrectly positioned due to both CV which wrote several incorrect parameters into the IGES file and to UGII which tried to draw the wrong style of radius dimension (see Section E-E).

- 7) Angular dimensions containing two witness lines (versus one witness line found in some of the angular dimensions in the checked IGES file) were incorrectly positioned by the UGII post-processor (see Detail 2).
- 8) Crosshatching was not received by MFD in both the unchecked and checked IGES files. This is because crosshatching is removed from the part file during DOEDEF prepping (see Section E-E).

5.3.2.2 CASE 2 - CHECKED IGES FILE

Interestingly, the Bellyband's checked IGES file transferred differently than the unchecked IGES file. To begin, the graphics were slightly different in appearance because the designer actually drafted the parts differently. Furthermore, even though the checked IGES file transfer contained the same graphical problems mentioned above, some items were improved and some impaired by the use of WED's database checking routine.

For example, some stray lines disappeared while others appeared in other places. This occurred when the WED drafter edited the part to correct errors reported by the checking routine. Upon filing the part, the CV database improperly cleaned and packed itself. This allowed stray lines to pre-process into the reissued IGES file. Unfortunately, it is known that the CV IGES pre-processor will unpredictably translate different IGES files following different editing sessions. Furthermore, the appearance of some dimensions improved while others declined. The incorrect location of the radius dimension improved slightly because the dimension regained its associativity through the checking process. However, the text of the dimension was still misplaced because of UG's attempt to change the style of the radius dimension. For angular dimensions, the results also improved with the checking routine's deletion of the duplicative witness lines. Now containing only one witness line, UG properly processed these angular dimensions.

5.3.2.3 CASE 3 - HPGL FILE

The HPGL data transferred well from WED's CAD system to MFD's HP plotter. MFD was able to re-create a visually equivalent engineering drawing.

5.4 DATA EXCHANGE SUMMARY

In most cases, the geometry entities that MFD desired transferred well in the IGES format. In the future, the use of double precision in WED's CAD systems will improve IGES transfers. The annotation entities which did not transfer as well will begin to translate acceptably as the vendors improve their pre- and post-processors. Efforts will be made to alert the CAD system vendors to the short-comings discovered in this test. Hopefully, the vendors will correct these issues in future versions of their products.

6.0 RECOMMENDATIONS

The Evaluation Team makes the following recommendations after consideration of the data collected during this study.

- 1) **WED should release HPGL and unchecked IGES files to MFD.**
 - HPGL files transfer the visual equivalent of the engineering drawing.
 - IGES files transfer geometry, which may be useful to NC and inspection programmers.
- 2) **MFD should check the geometry before manufacturing.**
 - WED can not guarantee the geometry transferred via IGES will be received by MFD with the decimal accuracy specified in the engineering drawing.
 - MFD will only use geometric entities for NC and inspection programming, while WED will check all entities (geometric and annotation) in the database.
 - MFD may only use selected entities from selected views of the engineering drawing.
- 3) **WED should transfer IGES files to MFD generated from a double precision database.**
 - This will improve the quality of the geometry transfer. MFD may receive geometric data with the identical decimal precision specified on the engineering drawing.
- 4) **Until recommendation number three is implemented, MFD should create splines from data in the contour tables, and not the contour data file.**
 - WED does not guarantee the text of the contour tables, even when generating an unchecked IGES file.
 - Data in the contour data file is not guaranteed.
- 5) **MFD should remove redundant effort on the part of the NC and inspection programmers.**
 - Automation routines can be written to perform IGES post-processing and other UG start-up sequences common to both NC and inspection practices.
- 6) **Both WED and MFD should keep their IGES processors updated to the current IGES version available from their respective CAD software vendors.**
 - Each release of IGES processing software is meant to fix problems with the previous release. This will further improve the quality of annotation entity transfers.

7.0 CONCLUSIONS

The goal of this study is to quantify the impact of accurate geometry in design, manufacturing and inspection of mechanical parts. Accurate geometry (engineering data) should be verified before or after transfer to a manufacturing site.

Engineering data transfer requires the use of both HPGL and IGES files. WED is assured through HPGL that MFD will reproduce a visually equivalent engineering drawing.

IGES is inadequate for generating a visually equivalent engineering drawing, but is satisfactory for transferring geometric information. The single precision issue creates a problem for MFD. Until WED transfers all geometry in double precision, MFD will need to evaluate the extent of IGES use on a per transfer basis. The determining criteria is if geometric data is transferable to UG in seven characters or less (e.g. X.XXXXX or XX.XXXX or XXX.XXX, etc.).

Table 4 shows the least amount of time was spent when WED checked the IGES file prior to its electronic transfer to MFD.

Table 4

Case 1 (Unchecked IGES)	49.25 hours
Case 2 (Checked IGES)	41.25 hours
Case 3 (Paper Drawing)	44.70 hours

However, the transfer of unchecked IGES files is currently recommended for the following reasons:

- 1) WED can not guarantee MFD will receive accurate geometry due to the precision problem.
- 2) Redundant effort for Case 1 (database checking for NC AND inspection programming) reduces the chance of incorrect part manufacture.
- 3) IGES use is more beneficial than no IGES use.
- 4) Time delays by the ERC eliminate Case 3.

The state of engineering data transfer is vastly improved when performed electronically as opposed to manual methods. Electronic data transfer can reduce the design to manufacturing cycle time by several days. However, implementing electronic data transfer through HPGL and IGES files is not all that can be done. Additional methods must be explored to further streamline the design to manufacturing cycle.

Appendix A

IGES Mapping Table From Computervision CADDStation v3.0 To Unigraphics II v7.0

CV entity name	Pre-processed with WED routine into IGES entity number and form	Post-processed into UGII entity? Y/N	UGII entity name
Adimension	202	yes	Dimension
Arc/Circle	100	yes	Arc
B-spline 1-3 deg	112	yes	Spline
B-spline 4-7 or w/RBS	126	yes	B-curve
B-surface 1-3 deg	114	yes	Sculptured surf
B-surface 4-7 deg	128	yes	B-surface
Surface mesh property	406 5558	no	-
B-surface w/ subrecord	140	yes	Appropriate surface
Centerline	106 20	yes	Centerline
Conic - Ellipse	104 1	yes	Conic
Conic - Hyperbola	104 2	yes	Conic
Conic - Parabola	104 3	yes	Conic
Cpole	126	yes	B-curve
Correct Node	132	yes	GSM node
Ddimension	206	yes	Dimension
Feature control sym	228	yes	Draft aid
Flag note	228	yes	Draft aid
General label	210	yes	Draft aid
or	228	yes	Draft aid
Local nodal figures	402 7	yes	Group
or	406 15	yes	Name attributes
Line	110	yes	Line
Ldimension	216	yes	Dimension
Mass point	116	yes	Point
or	406 5559	no	-
Nfigure	320	yes	GSM symbol master
Nfigure instance	420	yes	GSM symbol
Nodal line	106 12	yes	Lines, groups
or	402 18	no	-
Nodal subfigure	320	yes	GSM symbol master
Nodal subfig instance	420	yes	GMS symbol
Nodal text plus text	312	no	-
NURB Curve	126 0-5	yes	B-curve
NURB Surface	128 0-9	yes	Dimension
or	220	yes	Draft aid
Plane	108 +1,-1	yes	Bounded plane
Plus figure	308	yes	Reference set
or	125	no	-

CV entity name	Pre-processed with WED routine into IGES entry number and form		Post-processed into UGII entity? Y/N	UGII entity name
Point	116		yes	Point
Rdimension	222		yes	Dimension
Rectangle	106	63	yes	Lines, group
Relation (Group)	402	1	yes	Group
Rsurface	118	1	yes	Ruled surface
Rsurface w/ subrecord	140		yes	Appropriate surface
Shape	106	63	yes	Lines, group
String 2-D	106	11	yes	Lines, group
String 3-D	106	12	yes	Lines, group
Special line fonts	304	2	no	-
Subfigure definition	308		yes	Reference set
Subfigure instance	408		yes	Component
Spole	128		yes	B-surface
Srevolution	120		yes	Surface of revolution
Srevolution w/subrec	140		yes	Appropriate surface
Tcylinder	122		yes	Tabulated cylinder
Tcylinder w/subrecord	140		yes	Appropriate surface
Text	212		yes	Draft aid
Text node w/nodal text	312		no	-
Drawing	404		yes	Drawing
Drawing name	406	15	yes	Drawing name
Drawing units	406	17	yes	Drawing units
Drawing size	406	16	yes	Drawing size
View	410		yes	View
View name	406	15	yes	View name
Construction plane	124	0	yes	Transformation matrix
Layer discrim (color)	DE		yes	Color
Layer	DE		yes	Layer
Line fonts	DE		yes	Line fonts
Blank/unblank	DE		yes	Blank/unblank
View inclusion/excl	402	3	yes	Erased in view
View specific attrib.	402	4	no	-

Appendix B
Bellyband HPGL Sheets 1 and 2

REV	DATE	BY	CHKD

1. ALL DIMENSIONS UNLESS OTHERWISE SPECIFIED ARE IN INCHES.
 2. DIMENSIONS ARE TO CENTER UNLESS OTHERWISE SPECIFIED.
 3. DIMENSIONS ARE TO CENTER UNLESS OTHERWISE SPECIFIED.
 4. DIMENSIONS ARE TO CENTER UNLESS OTHERWISE SPECIFIED.
 5. DIMENSIONS ARE TO CENTER UNLESS OTHERWISE SPECIFIED.
 6. DIMENSIONS ARE TO CENTER UNLESS OTHERWISE SPECIFIED.

1. ALL DIMENSIONS UNLESS OTHERWISE SPECIFIED ARE IN INCHES.
 2. DIMENSIONS ARE TO CENTER UNLESS OTHERWISE SPECIFIED.
 3. DIMENSIONS ARE TO CENTER UNLESS OTHERWISE SPECIFIED.
 4. DIMENSIONS ARE TO CENTER UNLESS OTHERWISE SPECIFIED.
 5. DIMENSIONS ARE TO CENTER UNLESS OTHERWISE SPECIFIED.
 6. DIMENSIONS ARE TO CENTER UNLESS OTHERWISE SPECIFIED.

1. ALL DIMENSIONS UNLESS OTHERWISE SPECIFIED ARE IN INCHES.
 2. DIMENSIONS ARE TO CENTER UNLESS OTHERWISE SPECIFIED.
 3. DIMENSIONS ARE TO CENTER UNLESS OTHERWISE SPECIFIED.
 4. DIMENSIONS ARE TO CENTER UNLESS OTHERWISE SPECIFIED.
 5. DIMENSIONS ARE TO CENTER UNLESS OTHERWISE SPECIFIED.
 6. DIMENSIONS ARE TO CENTER UNLESS OTHERWISE SPECIFIED.

0

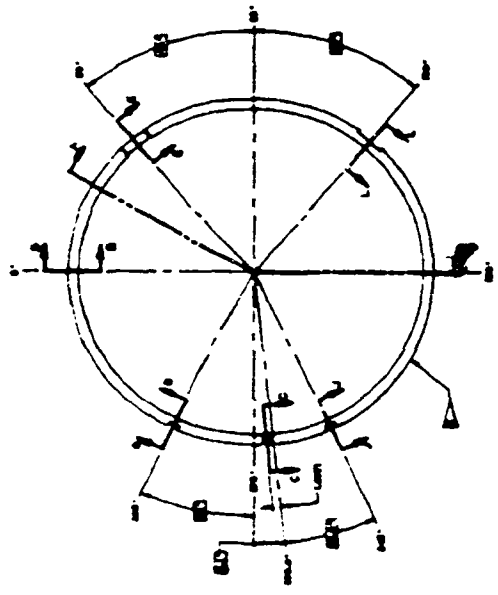
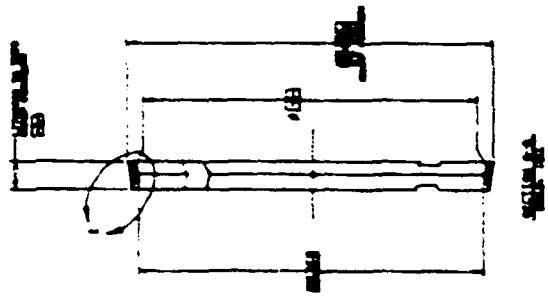
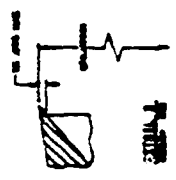
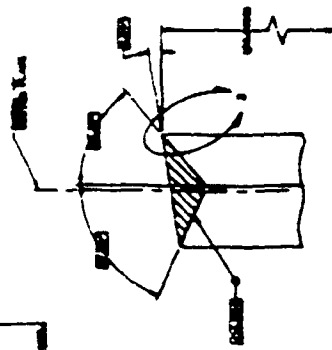
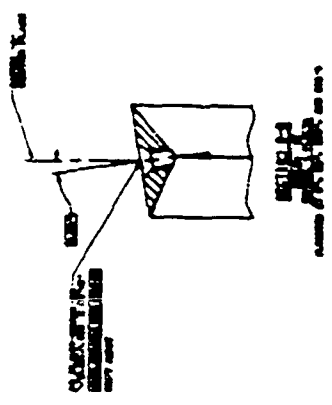

HPGL

REV	DATE	BY	CHKD

REV	DATE	BY

HPGL

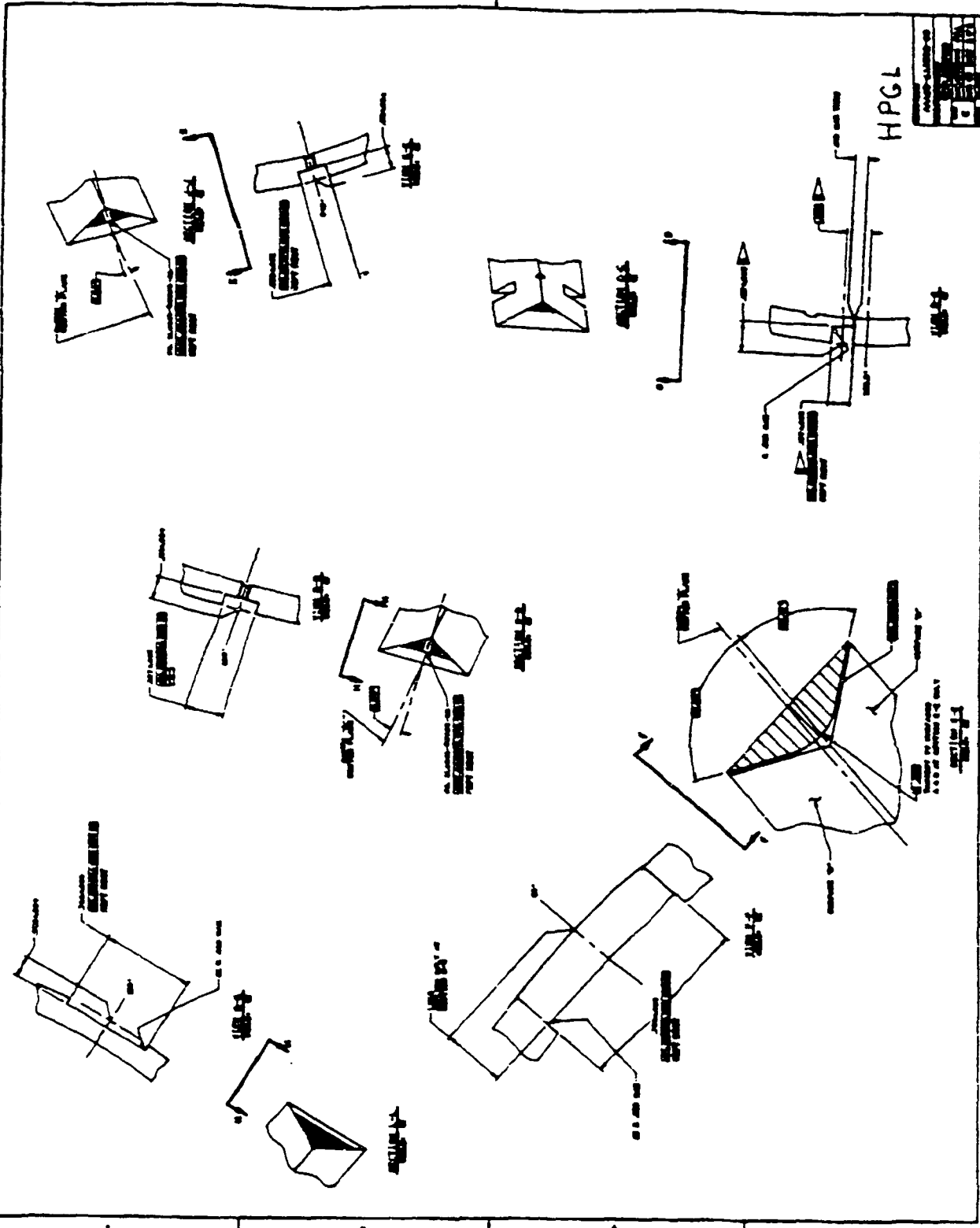

Appendix C

Bellyband Unchecked IGES Sheets 1 and 2

REV	DATE	BY	CHKD
0			

NO.	DESCRIPTION
1	...

NO.	DESCRIPTION
1	...

NO.	DESCRIPTION
1	...

NO.	DESCRIPTION
1	...

NO.	DESCRIPTION
1	...

NO.	DESCRIPTION
1	...

NO.	DESCRIPTION
1	...

NO.	DESCRIPTION
1	...

1. FINISH IS SHOWN AT END.
2. ALL DIMENSIONS ARE IN INCHES.
3. ALL DIMENSIONS ARE TO CENTER UNLESS OTHERWISE SPECIFIED.
4. ALL DIMENSIONS ARE TO CENTER UNLESS OTHERWISE SPECIFIED.
5. ALL DIMENSIONS ARE TO CENTER UNLESS OTHERWISE SPECIFIED.
6. ALL DIMENSIONS ARE TO CENTER UNLESS OTHERWISE SPECIFIED.
7. ALL DIMENSIONS ARE TO CENTER UNLESS OTHERWISE SPECIFIED.
8. ALL DIMENSIONS ARE TO CENTER UNLESS OTHERWISE SPECIFIED.

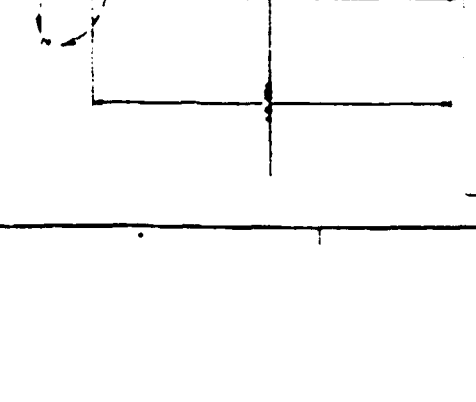
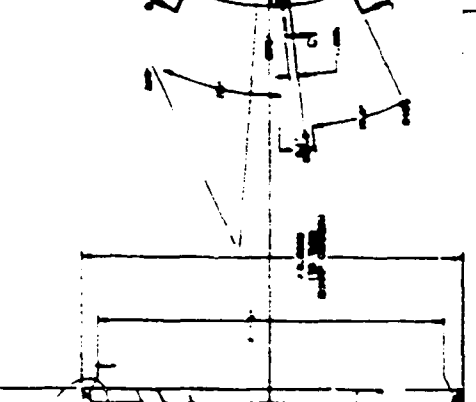
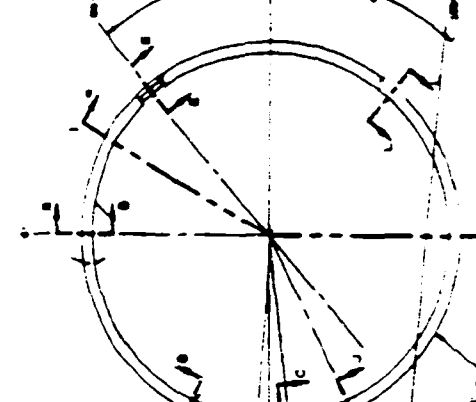
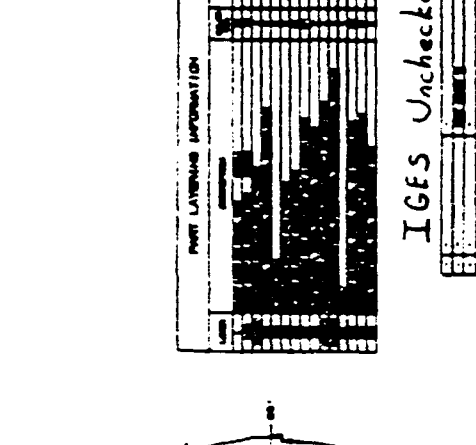
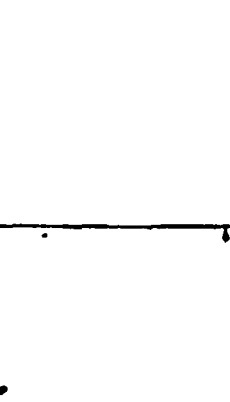
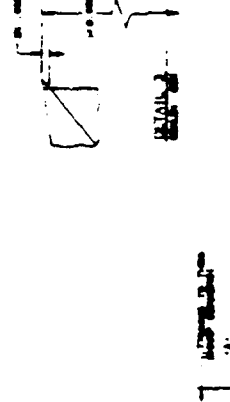
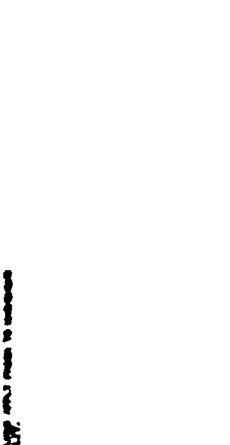

PART LAYERING INFORMATION	
NO.	DESCRIPTION
1	...

IGES Unchecked

NO.	DESCRIPTION
1	...

INACCURATE GEOMETRY
DO NOT USE FOR FABRICATION

Appendix D

Bellyband Checked IGES Sheets 1 and 2

0
 10000
 10000
 10000

0
 10000
 10000
 10000

0
 10000
 10000
 10000

0
 10000
 10000
 10000

0
 10000
 10000
 10000

1. PARTS TO BE SUBMITTED ALL OVER.
2. PARTS TO BE SUBMITTED ALL OVER.
3. PARTS TO BE SUBMITTED ALL OVER.
4. PARTS TO BE SUBMITTED ALL OVER.
5. PARTS TO BE SUBMITTED ALL OVER.
6. PARTS TO BE SUBMITTED ALL OVER.
7. PARTS TO BE SUBMITTED ALL OVER.
8. PARTS TO BE SUBMITTED ALL OVER.

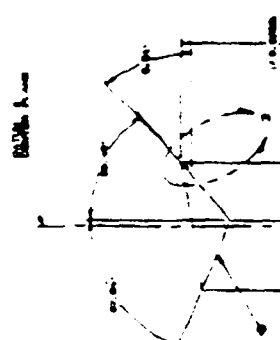
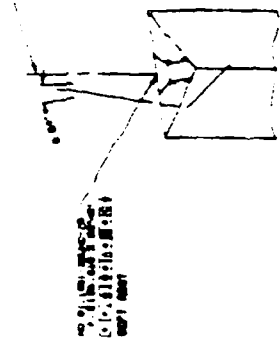

0
 10000
 10000
 10000

0
 10000
 10000
 10000

0
 10000
 10000
 10000

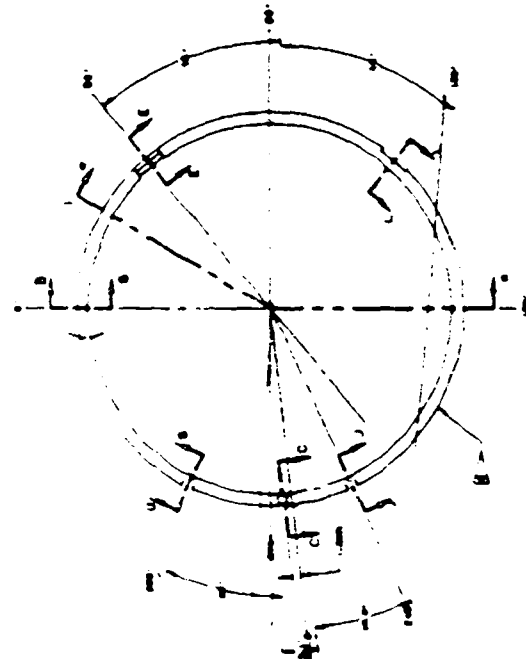
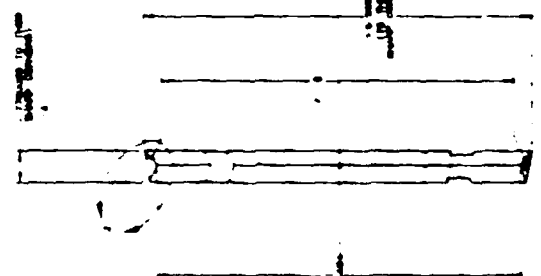
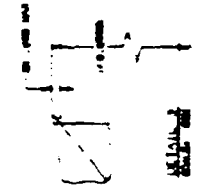

PART LAYERING INFORMATION

Layer Name	Color	Line Style
0	Black	Solid
1	Red	Dashed
2	Green	Dotted
3	Blue	Long Dash Short Dash
4	Magenta	Thin Solid
5	Cyan	Thin Dashed
6	Yellow	Thin Dotted
7	Black	Thin Long Dash Short Dash
8	Black	Thin Solid

IGES Checked

Part Name	Material	Quantity
0	Steel	1
1	Aluminum	2
2	Copper	1
3	Brass	1
4	Stainless Steel	1
5	Carbon Steel	1
6	Aluminum	1
7	Steel	1
8	Steel	1

ENCLOSURE

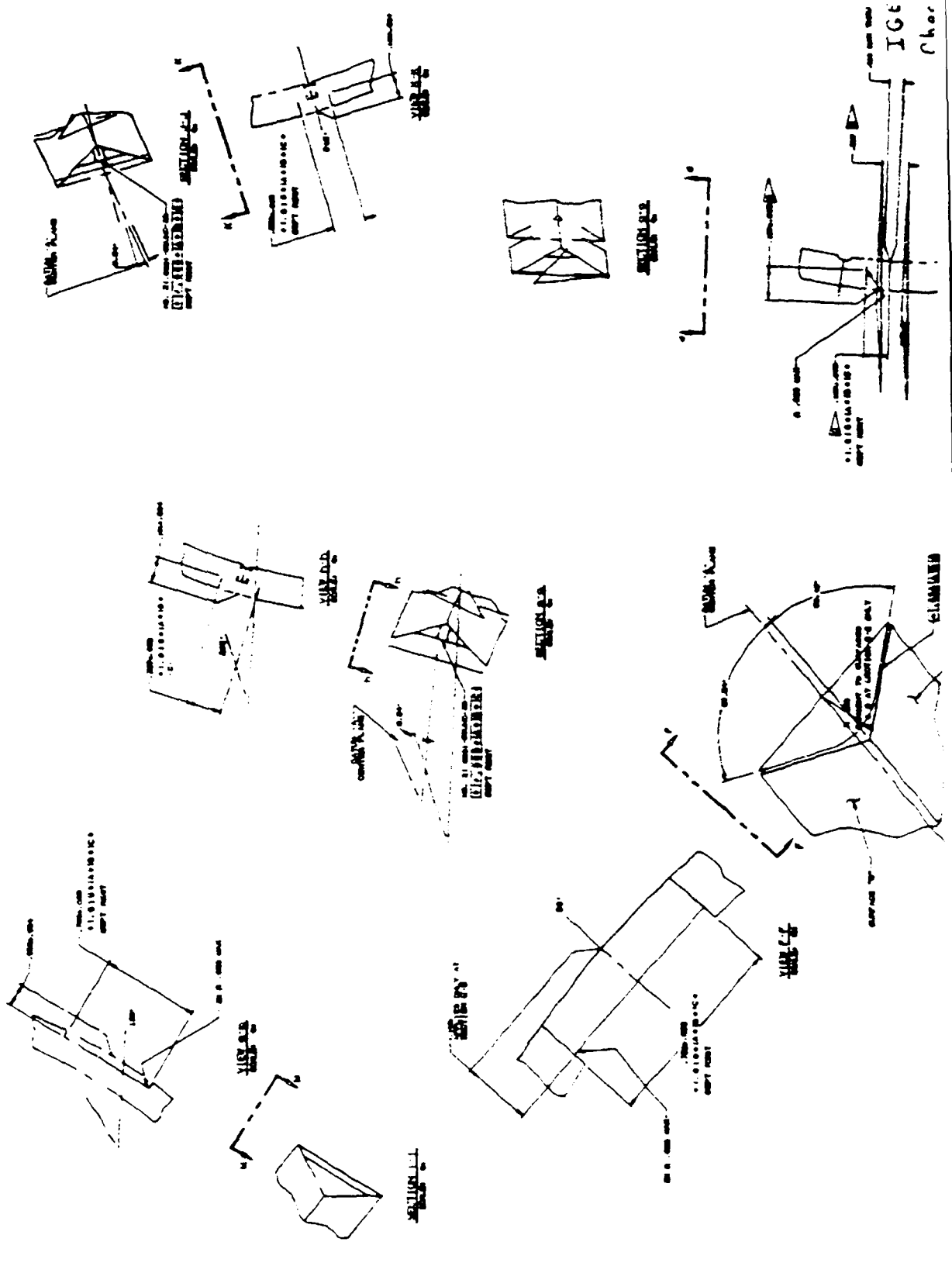

IGES
Charlottesville