

AD-A262 941**INATION PAGE**Form Approved
OMB No. 0704-0165Public
maintain:
sugges
and to:four per response, including the time for reviewing proposals, searching existing data sources, gathering and
ion. Send comments regarding this burden estimate or any other aspect of this collection of information, including
de for Information Operations and Reports, 1215 Jefferson Davis Highway, Suite 1204, Arlington, VA 22202-4302
(188) Washington, DC 20543

1 AGENCY USE ONLY (Leave blank)		2 REPORT DATE February 1993		3 REPORT TYPE AND DATES COVERED professional paper	
4 TITLE AND SUBTITLE DEEP OCEAN ARRAY HANDLING USING ROVs				5 FUNDING NUMBERS In-house funding	
6 AUTHOR(S) A. Fronk					
7 PERFORMING ORGANIZATION NAME(S) AND ADDRESS(ES) Naval Command, Control and Ocean Surveillance Center (NCCOSC) RDT&E Division San Diego, CA 92152-5001				8 PERFORMING ORGANIZATION REPORT NUMBER	
9 SPONSORING/MONITORING AGENCY NAME(S) AND ADDRESS(ES) Naval Command, Control and Ocean Surveillance Center (NCCOSC) RDT&E Division San Diego, CA 92152-5001				10 SPONSORING/MONITORING AGENCY REPORT NUMBER	
11 SUPPLEMENTARY NOTES					
12a. DISTRIBUTION/AVAILABILITY STATEMENT Authorized for public release; distribution is unlimited.				13 DISTRIBUTION CODE	
13. ABSTRACT (Maximum 200 words) The use of Remotely Operated Vehicles (ROVs), may assist in the installation of ocean sensors as long as their capabilities are understood. This paper describes a proof of concept experiment performed to test the ability of an ROV to install a simulated underwater array. The tests were performed by the NOSC Advanced Tethered Vehicle at a 2500 ft. site in September, 1991.					
14 SUBJECT TERMS remotely operated vehicles (ROVs) underwater array advanced tethered vehicle				15 NUMBER OF PAGES	
17 SECURITY CLASSIFICATION OF REPORT UNCLASSIFIED				18 SECURITY CLASSIFICATION OF THIS PAGE UNCLASSIFIED	
19 SECURITY CLASSIFICATION OF ABSTRACT UNCLASSIFIED				20 LIMITATION OF ABSTRACT SAME AS REPORT	

DTIC
SELECTE
APR 12 1993
S C D

93 4 09 043**93-07501**Published in *Proceedings of Intervention/ROV92*, June 1992.

UNCLASSIFIED

21a. NAME OF RESPONSIBLE INDIVIDUAL A. Fronk	21b. TELEPHONE (Include Area Code) (619) 553 1963	21c. TELETYPE CODE Code 942
---	--	--------------------------------

DEEP OCEAN ARRAY HANDLING USING ROVs

Alan Fronk

Naval Command, Control and Ocean Surveillance Center
RDT&E Division
Code 942
San Diego, California 92152-5000 USA

Approved For	
CLASS - CRAZI	<input checked="" type="checkbox"/>
DTIC TAB	<input type="checkbox"/>
Unannounced	<input type="checkbox"/>
Justification	
By	
Distribution	
Availability Codes	
Avail and/or Special	

AI 20

ABSTRACT

The use of Remotely Operated Vehicles (ROVs), may assist in the installation of ocean sensors as long as their capabilities are understood. This paper describes a proof of concept experiment performed to test the ability of an ROV to install a simulated underwater array. The tests were performed by the NOSC Advance Tethered Vehicle at a 2500 ft. site in September, 1991.

PURPOSE

Because the ocean engineering community has always been interested in improving deployment methods of ocean sensors, many sensor arrays of varying size and complexity have been studied and proposed. The methods of installation and deployment for these arrays are diverse and challenging because the intended sites range from shallow and benign to deep and hazardous. These deployment challenges reinforce the need to consider the deployment process in the preliminary stages of the array system design. One of the deployment tools which has become available to system designers is, of course, ROVs. Knowledge of the ROV's capabilities, limitations and liabilities is necessary for designers to use them effectively.

INTRODUCTION

In conjunction with the final testing and evaluation of the Advanced Tethered Vehicle, ATV, (see Figure 1) an experiment was conducted to test the ability of the vehicle to perform tasks related to underwater array installation work. The availability of ATV was an

excellent opportunity to test installation concepts and to evaluate vehicle performance in a real life situation. The tests were designed to simulate an array installation, which included actual hardware, cable, and pressure tolerant electrical components. The goals of the experiment were to determine the vehicle's ability to repeatedly locate objects, to reposition objects on the bottom of the ocean, to lay cable from object to object, and to connect cables. The test array was composed of a junction box, that formed the center of the array, relocatable nodes, interconnecting cables, and a cable continuity tester. The array installation consisted of four main procedures which were carried out several times during the course of the experiment. The vehicle had to locate an object previously placed on the bottom of the ocean, reposition components to a specified location, lay cable between the components of the array without destroying itself or the cable, and make and test electrical connections.

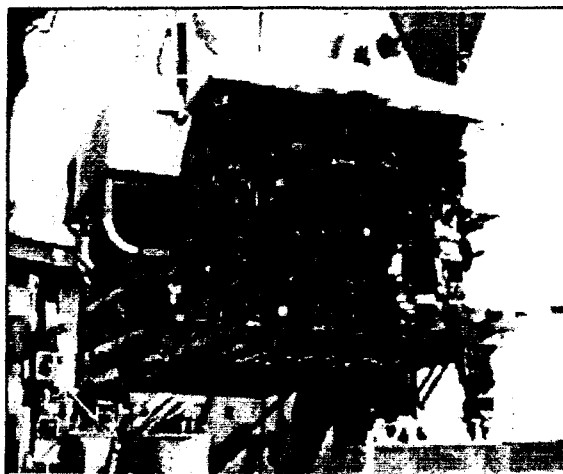

Figure 1 Advanced Tethered Vehicle

PROCEDURE

To satisfy design constraints, the test was composed of readily available components. The mechanical structure was composed of stock angle aluminum and the cables, two copper and two fiber optic, were very similar to, or the same as, cables used on other underwater projects. The electronics bottles for the continuity tester were built of oil-filled tubing, urethane, and pressure tolerant electronics. Ideally, wet mateable fiber optic connectors should have been used with the fiber optic cable, however, this type of connector was unavailable. While ATV was the vehicle used in the test, the electrical connection process was designed to be as simple as possible and not dependent on unique ATV features such as dual manipulators with position and force feedback sensing. The test array was composed of three main parts: the junction box, the nodes, and the cable spools. (See Figure 2.) The junction box was the main frame of the experiment and held all the components of the array. The two nodes contained the female half of the electrical connector and the continuity test circuit. The four spools contained the cable and the male half of the connector.

The junction box was designed to protect the spools and nodes during installation and deployment and to facilitate their removal by

ATV. The spools were held in place by a fixed bracket and then secured by a bolt and cotter pin. ATV removed the cotter pin from the bolt shaft by pulling on the attached lanyard, which allowed the bolt to fall free of the bracket. The spool was then lifted out of its bracket by the vehicle's arm. The nodes, held in the interior of the junction box were also secured by a bolt and cotter pin arrangement. After the removal of the cotter pin and bolt, the nodes were pulled out of the ends of the junction box by ATV. The junction box, loaded and ready to deploy, was 74" L x 60" W x 32" H and weighed 450 lbs dry.

The nodes were also built to be removed from the junction box and carried off by ATV to a new location. Two sets of electrical connectors and alignment plug assemblies were mounted in each node to serve as the base for two cable spool assemblies. When ATV placed the spool on the node, the alignment plug ensured the correct orientation of the electrical connector. The alignment bell, gravity and a little help from ATV ensured the proper alignment of the electrical connector. The nodes also contained the electronics, batteries, and LED displays for the continuity testers. The nodes were 36" L x 24" W x 18" H and weighed about 45 lbs dry, including the continuity tester.

The spool assemblies held the cable used for the experiment and consisted of a 16 in.

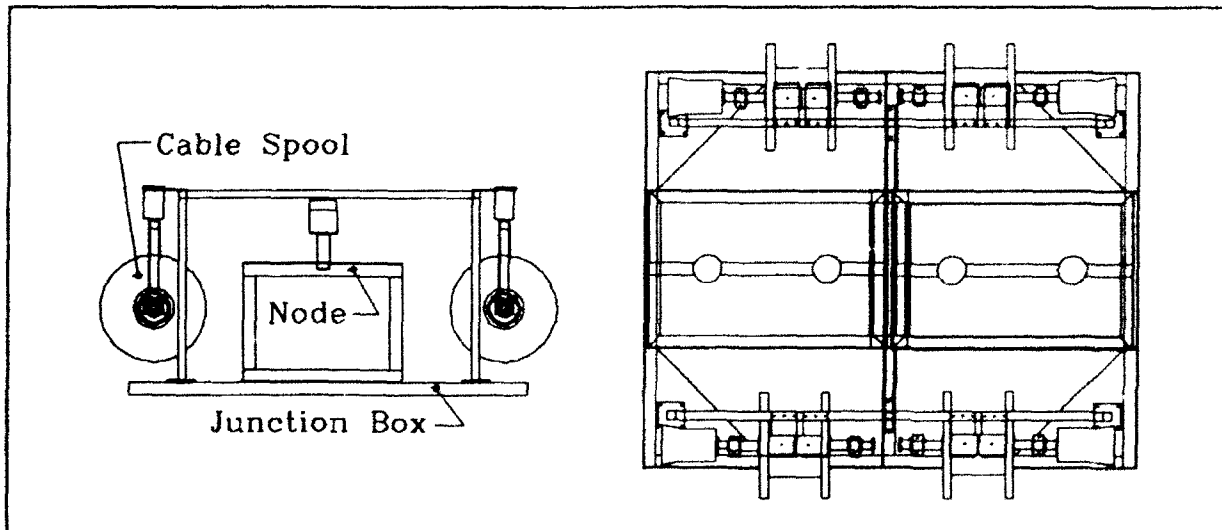

Figure 2 Junction Box with Nodes and Cable Spools Loaded

dia. plastic reel and a supporting bracket. A urethane binder, applied to the cable as it was wound on the spools, kept the cable from entangling on itself as the spools rotated, but still allowed the cable to pay out easily. A hollow axle extending from either side of the reel along its main axis provided the attachment point for the support bracket. The support bracket was a U-shaped yoke with a handle on the bottom and split bearings on the upper ends. The handle was the junction box attachment point and the primary manipulator grip. The yoke bearings clamped around the reel axles and allowed them to rotate. ATV could grasp on to the yoke at any point without impeding the rotation of the spool. The alignment bell and electrical connector were attached to one end of the axle which mated with the alignment plug and electrical connector on the node. When the spools were removed from the junction box, the free end of the cable remained attached to it so that the junction box formed the center of the array. The spools, at widest points, were approximately 32" L x 16" W x 26" H and weighed 45 lbs. (See Figure 3).

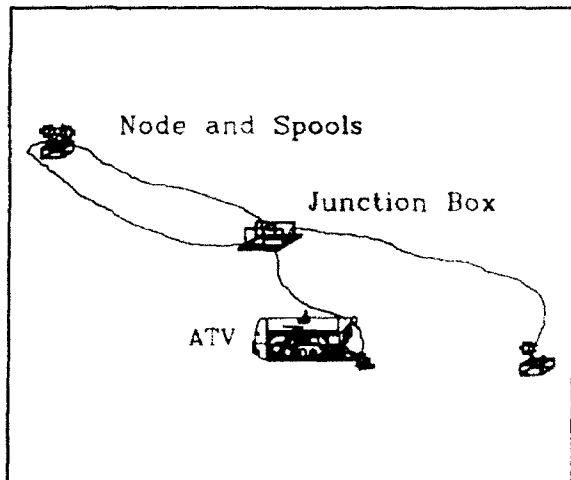

Figure 3 Array Deployment

One of the most important tests of the experiment was to determine the continuity of the cable after deployment. To do this, two continuity test circuits were required: one for each type of cable, copper and fiber optic. The continuity tester for the copper cable was no more than an oscillator circuit that was complete when the cable spool was plugged into the node and the cable was intact. The fiber optic test was slightly

more complex. An LED fiber optic emitter and oscillator circuit were permanently attached to the junction box end of the fiber cables. An optoelectric conversion circuit, at the other end, made up of a photodiode, amplifier, and LED driver was mounted inside the cable spool. This circuit was powered by batteries mounted on the node and was energized when plugged into the node. This test only responded to the presence or absence of a signal above the threshold level. Optical attenuation effects due to microbending, hocking, etc., were not measured. The circuit had enough excess signal and an low enough frequency to overcome most small attenuation problems. The display for all continuity testers consisted of an array of six green LEDs which were potted in urethane so that the body of the LED was exposed to sea water, while the electrical connection remained insulated. Previous tests proved the ability of ATV's cameras to clearly see the light given off by this display in most visibility situations encountered. In order to conserve power and enhance visibility, the LEDs were off when the circuit was incomplete, and strobed at a one Hertz rate when the circuit was continuous. One of the goals of the experiment was to use pressure tolerant electronics and batteries in the continuity testers. The fiber optic sources and receivers used were of a type that might be found in underwater array systems (1330nm., 100mw, single mode). They are generally packaged in small hermetically sealed metal cans, which usually crush under pressure. To protect these components from the effects of pressure they were first potted in hard epoxy, then soldered in the circuit and finally, with the entire circuit, potted in urethane. (See figure 4.) Plastic transistors, plastic integrated circuits, film resistors, LEDs and most nonelectrolytic capacitors have usually demonstrated good pressure tolerance. Several types of alkaline batteries have been tested in pressures up to 10,000 psi without failure. The batteries used in this test showed some deformation at 2000 psi but still provided sufficient output power and life. The electrical cable used in the test was a 2 conductor 16 awg 0.155 x 0.305 in. pvc covered electrical cord. The fiber optic cable was a 10/125 μ m. core/cladding fiber with a 500 μ m. buffer and a 10 strand steel armor with a 0.06 in. od plastic jacket.

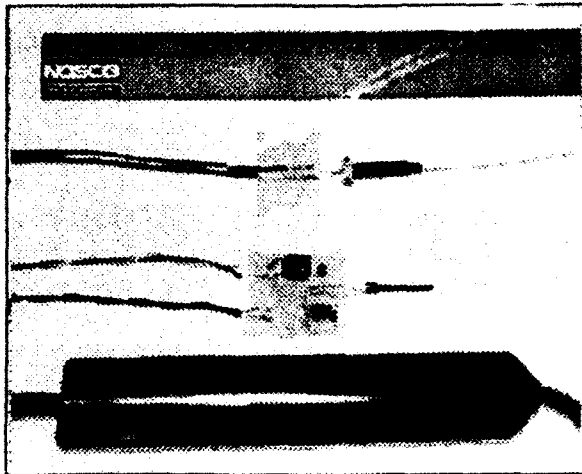

Figure 4 Fiber Optic Receiver and Transmitter

Another objective of the experiment was to make the electrical connection as simple as possible so that a large ROV would not be essential for this type of work. A four conductor underwater mateable connector made by OD Blue was used as the main electrical connector. This connector is built with one large pin that has four conductor rings spaced along its length. The connection is made by inserting the pin into the mating half and pushing the two halves together until they seat, without regard to connector rotation around the pin axis. Also the connector is tolerant to small misalignment and will self align if the offset is small. To take advantage of these properties, an alignment fixture was designed that would assist in the mating of the two halves and would prevent loading that could damage the connector. The plug half of the fixture, attached to the node, was a section of pipe four inches in diameter and six inches in length. The bottom of the pipe was closed off with a plate and mounting bracket. The last two inches of the pipe were tapered down from the outer diameter toward the inside. (See Figure 5.) The mating end, attached to the cable spool axle, was a section of pipe with a 4.25 in. inner diameter. The bottom was closed off with a plate and mounting bracket and the top was welded to a truncated cone that widened out to a five inch inner diameter. As the two halves were mated, the tapered end of the plug would make contact with the inside of the cone. As the plug was pushed further in, the cone would force it to the center of the fixture. At the inner end of the

cone, the taper of the plug would cause the two pipes to be concentric and would allow the plug to slide inside. The axis of the electrical connector was in line with the major axis of the fixture so that when the plug and bell were concentric and started to slide in, the electrical connector would be aligned. The connection was made when the halves were fully inserted. During the mating process the fixture would take all the force and keep the connector from being damaged. Holes on the bottom of the end plates allowed any trapped mud and silt to exit from the fixture so that it would not foul the connector or prevent full insertion and seating of the halves. The alignment fixture was oriented vertically on the node so that the effect of gravity would aid in the connection process and keep the two halves in place after ATV released the top half

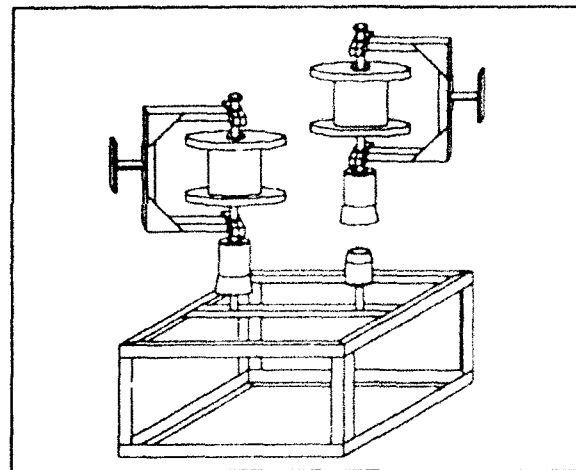

Figure 5 Cable Spool with Alignment Fixture and node.

The experiment would be conducted in the long baseline transponder field being used for ATV test and evaluation. The water in this location is approximately 2500 ft deep and the bottom is composed of mud and silt. The deployment scheme would be as follows. The junction box containing all the parts of the test would be lowered to the ocean floor before ATV was launched. The junction box would be released a short distance above the bottom by an acoustic release. This acoustic release would also be used to track the position and altitude of the junction box as it was lowered. After the

descent line had been recovered, ATV would be launched and would transit to the last known location of the junction box. After locating and inspecting the junction box, ATV would remove a node and carry it away about 400 feet. (see Figure 3) It would return to the junction box and reposition the other node 180 degrees away from the first. ATV would again return to the junction box, and remove the first cable spool, and fly to the nearest node. The cable spool would then be mounted on the alignment fixture on the node and the state of the cable continuity would be determined. After ATV finished checking the cable spool and node combination, it would return to junction box and deploy the remaining three spools in the same manner. After all the spools had been deployed, ATV would make one final inspection of the entire experiment area and return to the support ship for recovery.

RESULTS

On September 12, 1991, the junction box was lowered over the side of the Marsea Fifteen. After the acoustic release failed to function, the junction box was recovered, fitted with another release and then successfully redeployed and set on the ocean floor. (During the recovery of the junction box, however, the cable from one of the optical sources was severed and an emergency fiber optic repair was attempted.) ATV was launched and dove to the last charted location of

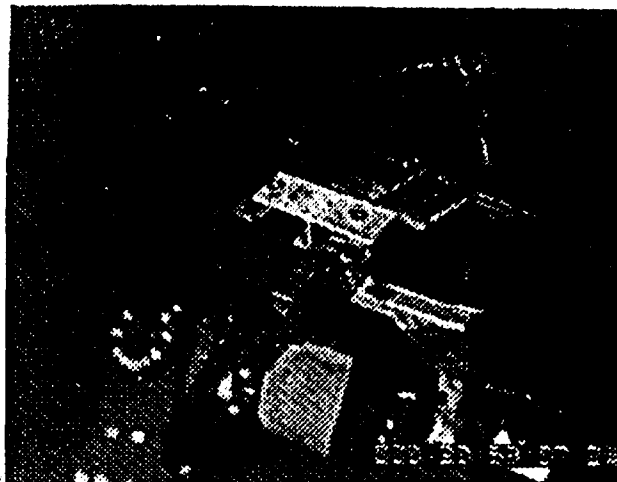

Figure 7 Spool Removal From Junction Box

the junction box. The junction box was easily identified on sonar and quickly found, even though it landed upside down and was partially embedded in the silt. After inspecting the site for a short time, ATV was easily able to right the 450 lb junction box without any apparent damage. Next, the first node was removed from the junction box and carried off and set down 400 ft away. (See Figure 6) ATV then similarly deployed the other node. The locations of the junction box and nodes were carefully recorded for future reference. The first cable spool was then removed from its bracket and carried to the first node. (See Figure 7). During the transit, ATV encountered no problems carrying and holding the spool which was carried to the side or behind the vehicle. The cable came off the spool without fouling on itself or the vehicle. There was

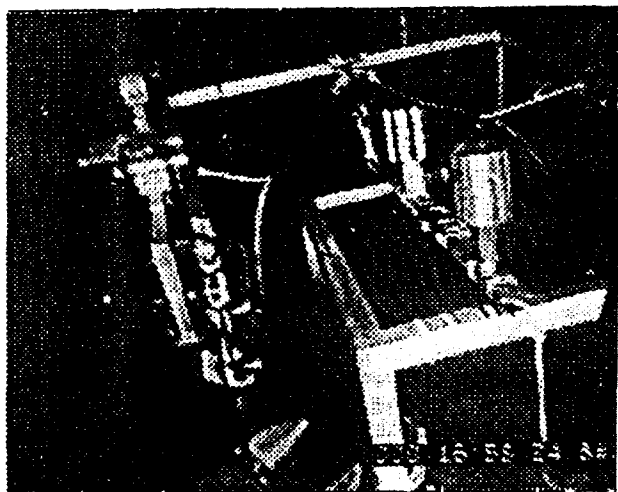

Figure 6 Node Removal From Junction Box

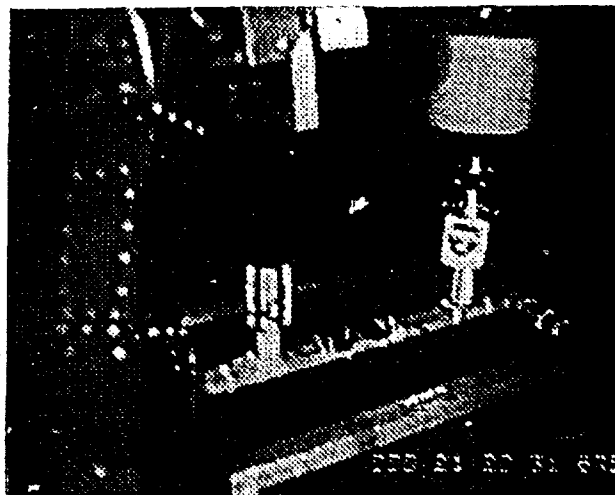

Figure 8 Spool and Node Connection

no tendency for the cable to be pulled into the thrusters nor wrap around the manipulator. This proved to be the case for all the spools in the experiment as well as three preliminary spools previously tested. Both types of cable laid flat without any evidence of hocking or kinking. When ATV reached the node, the spool was brought above the node and then placed on the mating fixture. (See Figure 8) The two halves of the fixture engaged and slid into position easily. The LED continuity display was quite visible and indicated a successful deployment. The vehicle returned to the junction box and repeated the

same procedure with a fiber optic spool. The remaining two spools were also deployed in the same manner. Three of the cable deployments were successful: the two copper and one fiber. The other fiber optic cable, which was severed during the installation of the junction box failed, the emergency splice apparently failed. The deployment of that spool, however, was as trouble free as the other three.

Aside from severing the fiber optic cable during the lowering of the junction box, very few problems were encountered. The combination of

Table I Deployment Times

	Time in Minutes (Sequential)											Ave Time	
Silt clearing time	1	1	2	3	1	5	1	1	3	1			15
Node pin removal time	5	9											5
Node removal time	3	11											7
Node removal to placement time	13	32											22
Spool pin removal time	1	1	1	1									1
Spool removal time	3	2	2	2									2
Spool connection time	3	5	1	2									2.8
Spool removal to connection time	34	27	63	24									37
ATV node-junction box transit time	12	10	13	11	11	13	16	17	14	9			12.7
ATV turn around time	7	15	4	2	2	7	5	9	41	2	6	7	9

Silt clearing time - The time from touch down of ATV to when the object could be clearly seen.

Node / spool pin removal time - Time required to remove securing pin from bolt.

Node / spool removal time - The time from ATV arriving at the junction box to the time leaving with the component.

Node removal to placement time - The total time for node placement.

Spool connection time - The time from ATV landing at the node to finishing the connection process.

Spool removal to connection time - The total time to remove and plug in a cable spool.

ATV node-junction box transit time - The transit time going/coming from the junction box to a node

ATV turn around time - Time from ATV landing to bringing work package to bear on object.

the sonar and navigation systems made the task of locating the nodes and junction box uncomplicated. The times required to deploy various parts of the experiment are summarized in Table 1.

The time required to complete a task in this experiment was entirely dependent on the skill of the operator. ATV is designed with the tether attached to the front end and the work package on the back end. The vehicle usually moves forward, tether end first, so that when an object is encountered the work package end is away from the object. It is necessary to spin the vehicle around to bring the work package to bear. The greatest variable in the test turned out to be the skill of the operator. Turning the vehicle around was the main source of problems. If done well, very little silt was stirred up, in fact it was possible for the vehicle to approach and land with the work package end in proper position without obscuring the object. If not done carefully, the object could be obscured and lost for some time, as once was the case. Even when the vehicle stirred up the bottom silt, it cleared quickly and was not a major problem in this test. When ATV was on site it was able to

complete the required tasks quickly. Several pilots operated the vehicle during the test and so it was not possible to extract performance trends from the data except to note that all the operators were able to complete the desired tasks if given sufficient time.

Three months later ATV returned to the test site and recovered the fiber optic spools. The photodiodes, associated electronics, and connectors were still functional.

The experiment showed that an ROV could do the type of work necessary to install an underwater array. The vehicle had to locate objects on the ocean floor and had to repeatedly return to those objects. It was able to reposition an object to whatever accuracy was desired, dependent on the time allowed to complete the task. It was able to lay out cable to interconnect portions of the array without fouling the cables on the vehicle nor breaking previously laid cables. Finally, it was able to make and test an electrical connection between array elements. The ROV, in this case, ATV, quite easily completed the tasks associated with this array simulation.