

AD-A263 660



CIM 172-Vol. II / July 1991

12

DTIC
ELECTE
MAY 6 1993
S C D

Job Performance Tests for Motor Transport Mechanics

Volume II: Administrative Duties and Job Knowledge Tests

Paul W. Mayberry
Neil B. Carey

DISTRIBUTION STATEMENT A

Approved for public release
Distribution Unlimited



CENTER FOR NAVAL ANALYSES

4401 Ford Avenue • Post Office Box 16268 • Alexandria, Virginia 22302-0268

93 5 05 196

93-09911



94px

APPROVED FOR PUBLIC RELEASE; DISTRIBUTION UNLIMITED.

Work conducted under contract N00014-91-C-0002.

This Information Memorandum represents the best opinion of CNA at the time of issue.
It does not necessarily represent the opinion of the Department of the Navy.

REPORT DOCUMENTATION PAGE

Form Approved
OPM No. 0704-0188

Public reporting burden for this collection of information is estimated to average 1 hour per response, including the time for reviewing instructions, searching existing data sources gathering and maintaining the data needed, and reviewing the collection of information. Send comments regarding this burden estimate or any other aspect of this collection of information, including suggestions for reducing this burden, to Washington Headquarters Services, Directorate for Information Operations and Reports, 1215 Jefferson Davis Highway, Suite 1204, Arlington, VA 22202-4302, and to the Office of Information and Regulatory Affairs, Office of Management and Budget, Washington, DC 20503.

1. AGENCY USE ONLY <i>(Leave Blank)</i>	2. REPORT DATE July 1991	3. REPORT TYPE AND DATES COVERED Final	
4. TITLE AND SUBTITLE Job Performance Tests for Motor Transport Mechanics - Volume II: Administrative Duties and Job Knowledge Tests		5. FUNDING NUMBERS C - N00014-91-C-0002 PE - 65153M PR - C0031	
6. AUTHOR(S) Paul W. Mayberry, Neil B. Carey		8. PERFORMING ORGANIZATION REPORT NUMBER CIM 172 - Volume II	
7. PERFORMING ORGANIZATION NAME(S) AND ADDRESS(ES) Center for Naval Analyses 4401 Ford Avenue Alexandria, Virginia 22302-0268		10. SPONSORING/MONITORING AGENCY REPORT NUMBER	
9. SPONSORING/MONITORING AGENCY NAME(S) AND ADDRESS(ES) Commanding General Marine Corps Combat Development Command (WF 13F) Studies and Analyses Branch Quantico, Virginia 22134		11. SUPPLEMENTARY NOTES	
12a. DISTRIBUTION/AVAILABILITY STATEMENT Approved for Public Release; Distribution Unlimited		12b. DISTRIBUTION CODE	
13. ABSTRACT <i>(Maximum 200 words)</i> Hands-on performance tests and job knowledge tests were developed for several motor transport mechanical maintenance specialities as part of the Marine Corps Job Performance Measurement Project. The purpose of this information memorandum is to disseminate these performance measures to Marine Corps personnel managers, training instructors, and interested researchers who may find them useful. This work comprises two parts: volume I contains the hands-on performance test, and this volume presents the administrative duties and job knowledge tests			
14. SUBJECT TERMS Hands-on tests, Instructions, Maintenance personnel, Marine Corps personnel, Mechanics, Performance (Human), Performance tests, Test methods			15. NUMBER OF PAGES 90
17. SECURITY CLASSIFICATION OF REPORT CPR			16. PRICE CODE
18. SECURITY CLASSIFICATION OF THIS PAGE CPR		19. SECURITY CLASSIFICATION OF ABSTRACT CPR	
20. LIMITATION OF ABSTRACT SAR			



CENTER FOR NAVAL ANALYSES

4401 Ford Avenue • Post Office Box 16268 • Alexandria, Virginia 22302-0268 • (703) 824-2000

8 July 1991

MEMORANDUM FOR DISTRIBUTION

Subj: CNA Information Memorandum 172

Encl: (1) CNA Information Memorandum 172, *Job Performance Tests for Motor Transport Mechanics, Volume II: Administrative Duties and Job Knowledge Tests*, by Paul W. Mayberry and Neil B. Carey, Jul 1991

1. Enclosure (1) is forwarded as a matter of possible interest.
2. Hands-on performance tests and job knowledge tests were developed for several motor transport mechanical maintenance specialties as part of the Marine Corps Job Performance Measurement Project. The purpose of this information memorandum is to disseminate these performance measures to Marine Corps personnel managers, training instructors, and interested researchers who may find them useful.
3. This work comprises two parts: volume I contains the hands-on performance test, and this volume presents the administrative duties and job knowledge tests.

Lewis R. Cabe

Director

Manpower and Training Program

DTIC QUALITY INSPECTED 5

Accession For	
NTIS	CRA&I <input checked="" type="checkbox"/>
DTIC	TAB <input type="checkbox"/>
Unannounced <input type="checkbox"/>	
Justification _____	
By _____	
Distribution /	
Availability Codes	
Dist	Avail and/or Special
A-1	

Subj: Center for Naval Analyses Information Memorandum 172

Distribution

SNDL

45A2 CG I MEF
45A2 CG II MEF
45B CG FIRST MARDIV
45B CG SECOND MARDIV
45Q CG FIRST FSSG
45Q CG SECOND FSSG
A6 HQMC MPR & RA
 Attn: Code MA
FT1 CNET
V12 CG MAGTEC
V12 CG MCCDC
 Attn: Studies and Analyses Branch
 Attn: Standards Branch (3 copies)

Job Performance Tests for Motor Transport Mechanics

**Volume II: Administrative Duties
and Job Knowledge Tests**

**Paul W. Mayberry
Neil B. Carey**

Operations and Support Division

CNA

CENTER FOR NAVAL ANALYSES

4401 Ford Avenue • Post Office Box 16268 • Alexandria, Virginia 22302-0268

ABSTRACT

Hands-on performance tests and job knowledge tests were developed for several motor transport mechanical maintenance specialties as part of the Marine Corps Job Performance Measurement Project. The purpose of this information memorandum is to disseminate these performance measures to Marine Corps personnel managers, training instructors, and interested researchers who may find them useful.

This work comprises two parts: volume I contains the hands-on performance test, and this volume presents the administrative duties and job knowledge tests.

CONTENTS

	Page
VOLUME I	
Introduction	1
Hands-On Performance Test	2
VOLUME II	
Introduction	1
Training Materials for Hands-On Test Administrators	1
Test of Administrative Duties	8
Job Knowledge Test	26

INTRODUCTION

The Marine Corps Job Performance Measurement (JPM) Project is a major effort to measure on-the-job performance of enlisted Marines. The performance measures are used to validate the enlistment test that selects and classifies military recruits. The performance tests also have value in providing unit commanders and training instructors with detailed information concerning the relative strengths and weaknesses of their personnel.

Representative military occupational specialties (MOSs) within the mechanical occupational field were selected for performance measurement. Hands-on performance tests and written job knowledge tests were developed. This document contains the performance tests for the motor transport mechanics that were tested (MOS 3521). A forthcoming CNA research memorandum will detail the test development process. The purpose of this document is to disseminate these performance measures to Marine Corps personnel managers, the training community, and interested researchers who may find them useful.

The performance measures are organized into the following sections:

- Hands-on performance tests with equipment/materials required for testing and procedures to set up each testing station
- Tests of administrative duties
- Job knowledge test with correct alternatives noted.

The test development and administration was conducted by the American Institutes of Research under subcontract to the Center for Naval Analyses.

TRAINING MATERIALS FOR HANDS-ON TEST ADMINISTRATORS

Retired and former Marine Corps staff noncommissioned officers were hired as test administrators. These individuals did not have a vested interest in the outcomes of the tests but were experienced in the mechanical maintenance occupational field and were accustomed to working with young Marines. Each task involved the performance of discrete and observable steps that could be scored objectively in a pass/fail format. To minimize any ambiguity or subjectivity associated with scoring the hands-on test, definitive scoring criteria were established and test administrators completed an extensive training course. This training focused on performing all tasks as well as learning the procedures involved in standardized test administration.

The following materials provide general guidelines for test administrators to observe in the conduct of hands-on testing. The guidelines focus on standardized test administration procedures and codes for professional conduct. Besides these requirements, test administrators were thoroughly instructed in the proper performance of each hands-on task.

A Guide for Test Administrators of USMC Mechanical Hands-on Tests

Prepared by the American Institutes for Research

Overview

Training of Hands-on Test Administrators (TAs) will be done essentially the same way at all test sites -- Camp Lejeune, MCAS New River, MCAS Tustin, and Camp Pendleton. The training cadre will be the same at all test sites to the greatest extent feasible.

The HO Test Stations are shown at the end of this Guide. **CAUTION:** The assignment of tests to stations is tentative. Assignments were made on the basis of time estimates and are subject to change pending tryout.

Each HO Test Site is comprised of eight fixed test stations, each manned by a TA. Each station covers one to several tasks. Each station will test for one hour. Examinees rotate to their next stations at the end of the hour. Eight Marines will complete HO testing daily.

The specific points that will be emphasized and practiced during TA training are included on the following pages.

1. Your Role as Scorers of Hands-On Tests

We will be training you to give the hands-on tests. Your role in this part of the project is critical. You've been hand picked because we think you know the tasks and can do a good job. Here are some general rules you must remember.

- A. Your job is to make it possible for each Marine to do the best job he can or wants to do on each test you give.
- B. Give clear instructions and be certain the Marine understands them.
 - (1) Look at the Marine. Practice the directions until you can read/speak them in a natural manner.
 - (2) Remember that while you may be giving the directions for the 15th time, it is the first time that the examinee has heard them.
- C. Follow the instructions on the scoresheet exactly as written -- do not shorten or add to them.
- D. Keep a professional demeanor. Show that you take the test seriously, and that the Marine being tested is doing something important and worthwhile.
- E. Be sure to complete all of the information asked for on the scoresheet.
- F. Score every performance measure every time. When you finish a test, scan the scoresheet to be sure there are no steps left blank.
- G. Practice good test security at all times.

- 1) We will promise the Marines that no one on the base will see their score or scoresheets.
 - 2) If anyone other than the project staff asks to see any of your scoresheets, politely refuse and refer them to the Hands-on Test Manager or Test Site Manager.
- H. Do not speak to the Marine being tested except when indicated on the scoresheet, or when allowed under the general rules laid out in the set-up sheet.
- I. Do not reveal, by the way you look or move what you think of the Marine's performance.
- 1) Sighs, frowns, raised eyebrows can affect the examinee's performance on your test subsequent tests.
 - 2) If a Marine asks how he did, just tell him you are not allowed to say.
- J. DO NOT coach, teach, help, train, in any way except when specified in the test materials.
- 1) If you are allowed to correct an error, do so without comment to the Marine.
 - 2) Be certain the Marine cannot correct his own error before stepping in.
 - 3) Some tests allow the Marine only one chance to perform the task or step correctly.
 - 4) Do not stop a test until the rules for stopping the test have been met.
 - 5) You may repeat instructions but in only the words printed on the scoresheet.

- 6) If the Marine asks during testing "What should I do next," or "Is this right," reply something like "Do the best you can," or "Do what you think is correct."

2. Giving the Hands-on Tests

A. At the beginning of every test day, you will be responsible for setting up an assigned test station.

- 1) You are responsible for ensuring that you have the equipment and materials you need to conduct the test.
- 2) The test station must be ready to begin testing immediately after the Marines arrive.

B. Each Marine being tested will have been briefed about the project and given a hands-on schedule sheet.

- 1) Copy his last name and ID onto his scoresheet and administer the tests at your station.
- 2) Retain the schedule until he has completed the station.
- 3) The Marine may not leave until he has taken all the tests at the station.
- 4) When he completes the testing, return the schedule and direct him to the next station at the assigned time.

C. You are responsible for maintaining good test conditions at your station.

- 1) You should not allow Marines not being tested to observe the test.

- 2) If a Marine does not cooperate, contact the Hands-on Test Manager or the senior Marine NCO.
- D. At the end of the session, review your scoresheets to be sure they are complete, put them in numerical order by ID, and give them to the Hands-on Test Manager in a folder.

TEST OF ADMINISTRATIVE DUTIES

In addition to the mechanical duties, a variety of administrative responsibilities are also assigned to automotive mechanics. These duties include the documentation of maintenance action performed, the use of technical manuals, and the ordering of parts from the supply system. These skills were also tested. Following are the tests administered to assess the administrative skills of automotive mechanics. Two forms of the test were produced: one for the M923 vehicle and another for the M998 vehicle.

Use of Forms and Manuals

Do not write or make marks in this booklet.

This is a test of your ability to work with manuals and to complete forms that 3521 mechanics use on the job. When the instructions say "use the appropriate form," you must select what you think is the correct form from the stacks on the table, and then fill it out.

Follow these instructions:

- 1. Write your name (last, first, MI), Social Security Number, and the Identification Number assigned to you on the first morning of testing in the spaces provided on the Using Manuals Question and Answer Form.**
- 2. This test booklet presents a number of scenarios that require you to complete a form that mechanics use. Select what you think is the correct form from the stacks on the table, and then fill it out.**
- 3. Next, read the questions on the Using Manuals Question and Answer form. Look up information in the TMs to answer these questions. Write your answers on the Using Manuals Question and Answer Form.**
- 4. When you have finished, put the completed forms, the Using Manuals Questions and Answer Form, and this test booklet back in the envelope and wait for the Test Administrator.**

If you have questions, ask the Test Administrator in the room.

COMPLETING FORMS

1. **An M923 is brought to your shop for maintenance. You are ready to begin working on this truck.**

Select the appropriate form and complete it to report your activity, using the information provided below:

- radiator leaks
 - turbo-charger leaks
 - service brake pedal pad is worn through to show metal
 - tow pintle is broken
-

2. **While reading TM 9-2320-272-20-1 (Oct 1985), you find an error on page 2-228, paragraph 24 (see following page). Items #1 and #2 are mismarked in the figure.**

Select the appropriate form and complete it to report your findings.

3. **Your unit has just received an M923 from the base supply point. Create a new record containing the correct information so that you can transfer the vehicle to another unit.**

Select the appropriate form and complete it using the information below. Record dates using the Julian calendar. Your AAC is 32101.

- antifreeze was changed on Jan 21, 1987
- speedometer was replaced on Feb 10, 1989 (odometer reading: 23,020M)
- unit received this truck on Dec 31, 1986
- the truck was manufactured by Ford Motor Company in 1985
- MI/MT No. 315001, to the starter mounts was completed on Nov 12, 1988
- tires were rotated on Oct 15, 1988
- engine was replaced on Apr 25, 1990 (old ser no GA 194006)
- vehicle was transferred on May 16, 1990 to MMSA-02 with voucher no. BM001

Table 2-12. Compressed Air and Brake System Troubleshooting (Cont'd)

MALFUNCTION	TEST OR INSPECTION	CORRECTIVE ACTION
-------------	--------------------	-------------------

24. HORN DOES NOT WORK (GAGES AT NORMAL OPERATING PRESSURE, WARNING BUZZER NOT SOUNDING)

Test 1. Check air supply at air electric valve (1).

Loosen supply line (2) very slowly.

- a. If air is not heard escaping, repair or replace defective supply line (2).
- b. If air supply is present, go to electrical troubleshooting, table 2-3.

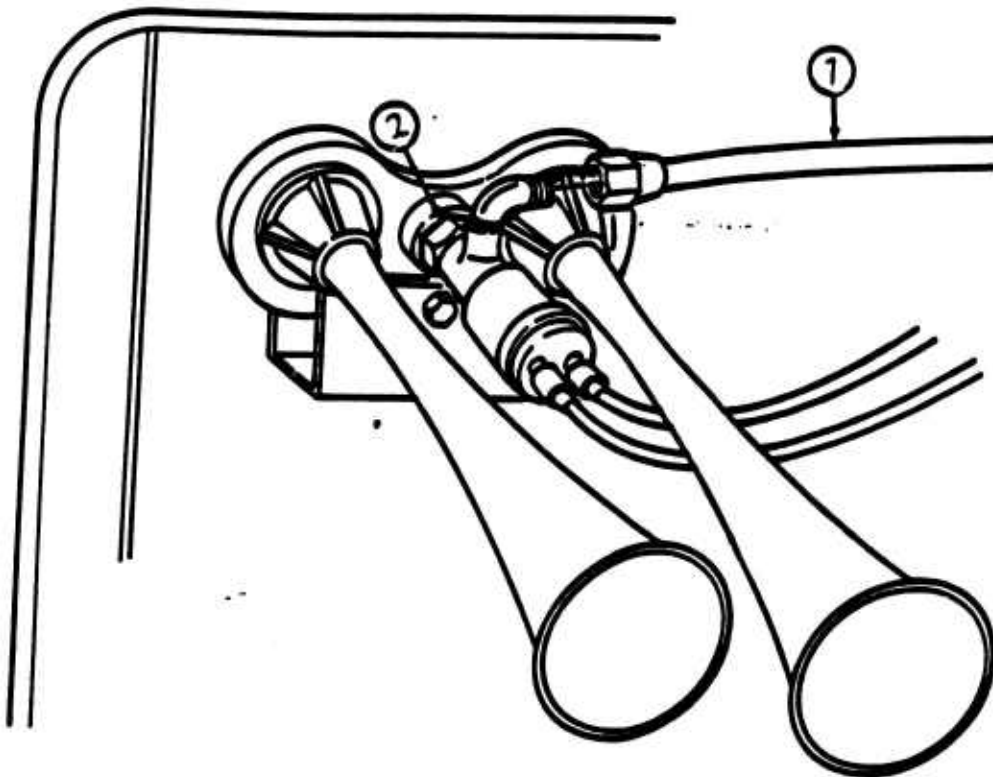

Name: _____

SSN: _____

ID #: _____

LIMITED TECHNICAL INSPECTION MOTOR TRANSPORT (47301)
NAVMC 12284 REV 9 72 54 0000 00 003 1905 U 1 PAD 100 SHEETS PER PAD
PREVIOUS EDITIONS ARE OBSOLETE AND WILL NOT BE USED

TYPE OF VEHICLE TRK, CARGO	UNIT ASSIGNED 12th MAB	SIZE 5 TON	DRIVE 6x6	VEHICLE NO
MANUFACTURER	MODEL M923	CHASSIS SERIAL NO	YEAR OF MANUFACTURE	USMC NO
CONDITION CODE <input type="checkbox"/> A <input type="checkbox"/> B <input type="checkbox"/> C <input type="checkbox"/> D <input type="checkbox"/> E <input type="checkbox"/> F <input type="checkbox"/> G <input type="checkbox"/> H <input type="checkbox"/> W <input type="checkbox"/> X <input type="checkbox"/> Y <input type="checkbox"/> Z				MILEAGE

GROUP	PART	SATISFACTORY			COST	GROUP	PART	SATISFACTORY			COST	MILEAGE	MILEAGE
		REPAIR	REPLACE	MISSING				REPAIR	REPLACE	MISSING			
01	ENGINE					15	FRAME						
02	CLUTCH					15	TOWING CONNECTIONS						
03	CARBURETOR					16	SHOCK ABSORBERS						OTHER SHORTAGES
03	FUEL PUMP					16	SPRINGS						
03	FUEL TANK					17	FENDERS						
03	DIESEL MULTIFUEL					17	HOOD						
	(a) INJECTORS					18	BODY						
	(b) METER PUMP					18	CAB						
	(c) TURBOCHGR					18	FLOOR						
	(d) FLAME HTR					18	GLASS						MAJOR DAMAGE OBVIOUSLY DUE TO OTHER THAN FAIR WEAR AND TEAR
04	MUFFLER AND TAIL PIPE					18	INTERIOR TRIM						
05	FAN & WATER PUMP					18	SEATS AND UPHOLSTERY						
05	RADIATOR					20	WINCH						
06	BATTERY					21	BRUSH GUARD AND GRILL						LETTER OF INVESTIGATION REFERENCE
06	DISTRIBUTOR					21	BUMPERS						
06	GENERATOR					22	VEHICLE ACCESSORIES						LETTER OF UNSERVICEABLE PROPERTY REFERENCE
06	LIGHTS					22	CANVAS						
06	STARTER					22	INSTRUMENTS						
06	REGULATOR					27	ARMAMENT						
06	WIRING					28	PAINT						
07	TRANSMISSION					29	FIFTH WHEEL						
08	TRANSFER					30	DUMP HOIST						
09	DRIVE SHAFT					31	WRECKER BOOM						
10	FRONT AXLE												
11	INTERMEDIATE AXLE												
11	REAR AXLE												
12	HAND BRAKE SYSTEM												
12	SERVICE BRAKE SYSTEM												
13	TIRES												TOTAL COST OF THESE REPAIRS \$
13	TRACKS												
13	WHEELS												INDIVIDUAL REPAIR EXPENDITURE LIMIT \$
14	STEERING GEAR												

REMARKS

ACTIVITY

-12-

DATE

SIGNATURE OF MAINTENANCE OFFICER

Name: _____

SSN: _____

USING MANUALS Examinee ID # _____
QUESTION AND ANSWER FORM

TRUCK (circle one): 998 923

1. You are ordering a tail light for an M923, and need to look up the SMR code.

A) the authorized echelon for repair and disposition of the part is:

B) the TM Number is: _____

C) the page number(s) is/are: _____

2. You want to order a front shock absorber for an M923.

A) the SMR code is: _____

the FSCM is: _____

the Part Number: _____

the Usable On Code: _____

B) the TM Number is: _____

C) the page number(s) is/are: _____

3. You are getting ready to work on the exhaust system of an M923. You want to first look up the safety precautions for working around exhaust gases.

A) the symptoms for exhaust poisoning are: _____

B) the TM Number is: _____

C) the page number(s) is/are: _____

4. The transfer on an M923 has been leaking after operation. You have just determined that all of the seals and gaskets are okay.

A) what should you do next? _____

B) the TM Number is: _____

C) the page number(s) is/are: _____

5. You are preparing to torque the lugnuts on an M923.

A) how tight, and in what pattern, should you torque the lugnuts?

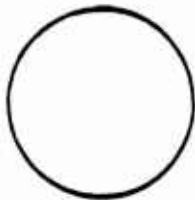

B) the TM Number is: _____

C) the page number(s) is/are: _____

6. You have determined that the transmission oil cooler hoses on an M923 must be replaced.

A) the ecnelon authorized to replace these hoses is:

B) the TM Number is: _____

C) the page number(s) is/are: _____

Use of Forms and Manuals

Do not write or make marks in this booklet.

This is a test of your ability to work with manuals and to complete forms that 3521 mechanics use on the job. When the instructions say "use the appropriate form," you must select what you think is the correct form from the stacks on the table, and then fill it out.

Follow these instructions:

1. Write your name (last, first, MI), Social Security Number, and the Identification Number assigned to you on the first morning of testing in the spaces provided on the Using Manuals Question and Answer Form.
2. This test booklet presents a number of scenarios that require you to complete a form that mechanics use. Select what you think is the correct form from the stacks on the table, and then fill it out.
3. Next, read the questions on the Using Manuals Question and Answer form. Look up information in the TMs to answer these questions. Write your answers on the Using Manuals Question and Answer Form.
4. When you have finished, put the completed forms, the Using Manuals Questions and Answer Form, and this test booklet back in the envelope and wait for the Test Administrator.

If you have questions, ask the Test Administrator in the room.

COMPLETING FORMS

1. **An M998 is brought to your shop for maintenance. You are ready to begin working on this truck.**

Select the appropriate form and complete it to report your activity, using the information provided below:

- one battery is cracked
 - both front tires are worn
 - windshield is cracked
 - fuel tank is cracked
-

2. **While removing/replacing a u-joint assembly from the rear propeller shaft on an M998, you notice an error with the instructions in the TM. The manual (April, 1985) has the labels for the bearing cups and the cross reversed on page 6-11 (see following page).**

Select the appropriate form and complete it to report your findings.

3. **Your unit has just received an M998 from the base supply point. Create a new record containing the correct information so that you can transfer the vehicle to another unit.**

Select the appropriate form and complete it using the information below. Record dates using the Julian calendar. Your AAC is 07199.

- antifreeze was changed on Jan 1, 1989
- transfer gear box was replaced on Nov 15, 1989
- speedometer was replaced on Feb 28, 1989 (odometer reading: 23,020M)
- differential oil was changed on Dec 31, 1988
- unit received this truck on Dec 31, 1986
- vehicle was lubed on Feb 15, 1990
- MI/MT No. 071989, to the engine mounts was completed on Jan 31, 1990
- vehicle was transferred on Feb 14, 1990

6-6. UNIVERSAL JOINT REPLACEMENT

This task covers:

a. Disassembly

b. Assembly

INITIAL SETUP:

Materials/ Parts

Journal and bearing kit:
front 5-419X
rear 5-273X

Personnel Required

One mechanic
One assistant

Manual References

TM 9-2320-280-20P

Equipment Condition

Propeller shaft removed (para. 6-3 or 6-4).

a. Disassembly

CAUTION

Do not drop bearing cups. Needle bearings can be easily lost.

1. Remove two bearing cups (1) from cross (4).
2. Remove two snaprings (2) from yoke (5).
3. Position propeller shaft (3) in vise with 1-1/8 in. (28 mm) socket between vise jaw and bearing cup (1) being removed. Ensure open end of socket is facing bearing cup (1).
4. Place 11/16 in. (17 mm) socket between opposite bearing cup (1) and vise jaw. Ensure open end of socket is facing vise jaw.
5. Press bearing cup (1) out of yoke (5) and remove bearing cup (1) from cross (4).
6. Reverse position of sockets and press remaining bearing cup (1) out of yoke (5).
7. Remove cross (4) from yoke (5).

b. Assembly

CAUTION

Ensure grease fitting on cross faces yoke. Damage to equipment will result if improperly installed.

1. Install cross (4) into yoke (5).
2. Install bearing cup (1) into yoke (5).

CAUTION

Ensure bearing cup is aligned with yoke before pressing in with vise. Damaged cross and bearing cups will result if forced into yoke.

3. Place yoke (5) in vise with 11/16 in. (17 mm) socket between vise jaw and bearing cup (1).
4. Press bearing cup (1) into yoke (5) far enough to install snapring (2) and install snapring (2) into yoke (5).
5. Install bearing cup (1) into yoke (5).
6. Place yoke (5) in vise with 11/16 in. (17 mm) socket between bearing cup (1) and vise jaw.
7. Press bearing cup (1) into yoke (5) far enough to install snapring (2) and install snapring (2) into yoke (5).
8. Install two bearing cups (1) on cross (4).

6-6. UNIVERSAL JOINT REPLACEMENT (Cont'd)

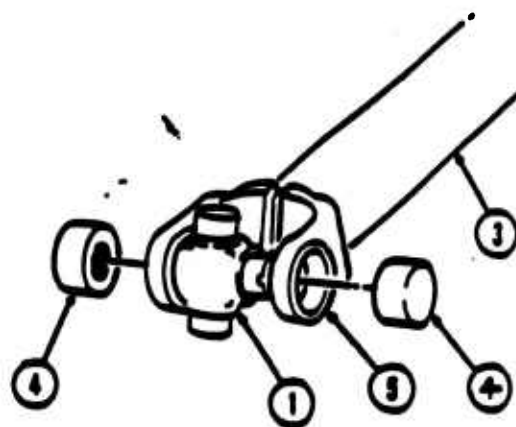
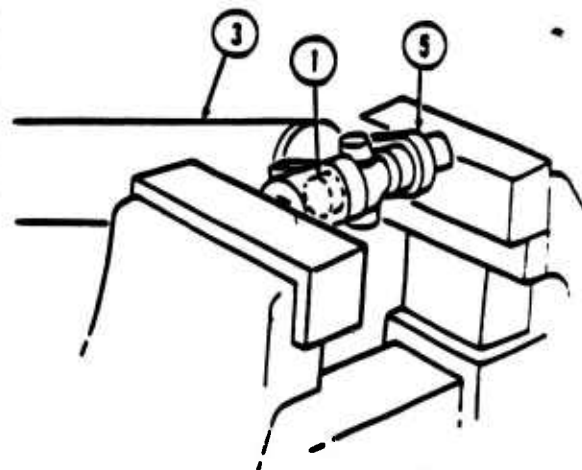
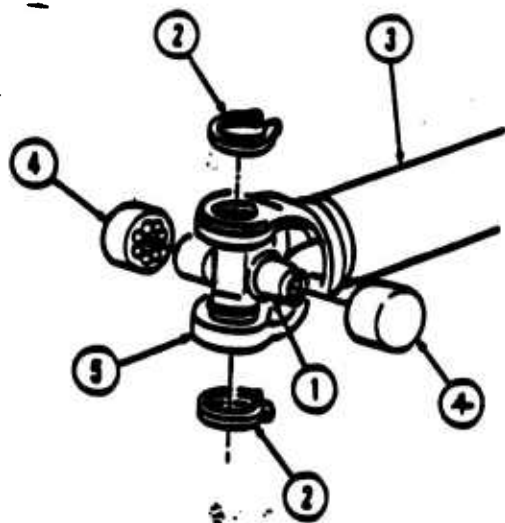

FOLLOW-ON TASK: Install propeller shaft (para. 6-3 or 6-4).

Name: _____

SSN: _____

ID #: _____

TYPE OF VEHICLE TRK, CARGO	UNIT ASSIGNED HQ BTRY 12th MAR	SIZE 1 1/4 T	WHEELS 4x4
MANUFACTURER	MODEL M998	CHASSIS SERIAL NO	YEAR OF MANUFACTURE
CONDITION CODE <input type="checkbox"/> A <input type="checkbox"/> B <input type="checkbox"/> C <input type="checkbox"/> D <input type="checkbox"/> E <input type="checkbox"/> F <input type="checkbox"/> G <input type="checkbox"/> H <input type="checkbox"/> I <input type="checkbox"/> J <input type="checkbox"/> K <input type="checkbox"/> L <input type="checkbox"/> M <input type="checkbox"/> N <input type="checkbox"/> O <input type="checkbox"/> P <input type="checkbox"/> Q <input type="checkbox"/> R <input type="checkbox"/> S <input type="checkbox"/> T <input type="checkbox"/> U <input type="checkbox"/> V <input type="checkbox"/> W <input type="checkbox"/> X <input type="checkbox"/> Y <input type="checkbox"/> Z <input type="checkbox"/> Z			MILEAGE

GROUP	PART	SATISFACTORY	REPAIR	REPLACE	MISSING	COST	GROUP	PART	SATISFACTORY	REPAIR	REPLACE	MISSING	COST	MATERIAL TO BE MADE
01	ENGINE						15	FRAME						
02	CLUTCH						15	TOWING CONNECTIONS						
03	CARBURETOR						16	SHOCK ABSORBERS						OTHER SHORTAGES
03	FUEL PUMP						16	SPRINGS						
03	FUEL TANK						17	FENDERS						
03	DIESEL MULTIFUEL						17	HOOD						
	(a) INJECTORS						18	BODY						
	(b) METER PUMP						18	CAB						
	(c) TURBOCHGR						18	FLOOR						MAJOR DAMAGE OBVIOUSLY DUE TO OTHER THAN FAIR WEAR AND TEAR
	(d) FLAME HTR						18	GLASS						
04	MUFFLER AND TAIL PIPE						18	INTERIOR TRIM						
05	FAN & WATER PUMP						18	SEATS AND UPHOLSTERY						
05	RADIATOR						20	WINCH						
06	BATTERY						21	BRUSH GUARD AND GRILL						LETTER OF INVESTIGATION REFERENCE
06	DISTRIBUTOR						21	BUMPERS						
06	GENERATOR						22	VEHICLE ACCESSORIES						LETTER OF UNSERVICEABLE PROPERTY REFERENCE
06	LIGHTS						22	CANVAS						
06	STARTER						22	INSTRUMENTS						
06	REGULATOR						27	ARMAMENT						
06	WIRING						28	PAINT						
07	TRANSMISSION						29	FIFTH WHEEL						
08	TRANSFER						30	DUMP HOIST						
09	DRIVE SHAFT						31	WRECKER BOOM						
10	FRONT AXLE													
11	INTERMEDIATE AXLE													
11	REAR AXLE													
12	HAND BRAKE SYSTEM													
12	SERVICE BRAKE SYSTEM													
13	TIRES													TOTAL COST OF THESE REPAIRS \$
13	TRACKS													
13	WHEELS													INDIVIDUAL REPAIR EXPENDITURE LIMIT \$
14	STEERING GEAR													

REMARKS _____

ACTIVITY	DATE	SIGNATURE OF MAINTENANCE OFFICER
----------	------	----------------------------------

Name: _____
 SSN: _____
 ID #: _____

PART 1
 LINES 10 PLUS SUPPLEMENTAL NUMBERING AREA

PUBLICATION NO. (SL/TM)	PUBLICATION DATE	SERIES NAME (TYPE, MODEL NO., AND)
-------------------------	------------------	------------------------------------

PAGE NO.	PARAGRAPH	FIELD NO.	ITEM NO.	IN THIS SPACE TELL WHAT IS WRONG AND CHANGE TO BE MADE
BE BOLD - POINT WHERE IT IS				

(IF THIS CODE IS PRINTED, NOTHING IS BEING DONE)

APPROVED BY (Print name, grade, organization, AUTOVON NO.) _____

DATE _____

ACTION TAKEN:

CORRECTION CHANGE WILL BE REFLECTED IN _____

NON-CORRECTION AND COMMENT

MATTER REFERRED TO THE FOLLOWING ORGANIZATION FOR REPLY:

APPROVED BY (Print name, grade, organization, AUTOVON NO.) _____

DATE _____

PART 2
 LINES 10 LOGISTICS - MAINTENANCE - DATA CODES (A.A. CODE) - TECHNICAL AND GENERAL APPROVED (OTHER THAN CODES)

WHEN APPLICABLE, FURNISH THE FOLLOWING DATA:

NO.	PARTICULAR NO.	ID
APPLICABLE	AGENCY CODE	CHANGE TO CODE
SL/TM PLUS HELFUS DATE		

JUSTIFICATION FOR RECOMMENDED CHANGE:

(IF THIS CODE IS PRINTED, NOTHING IS BEING DONE)

APPROVED BY (Print name, grade, organization, AUTOVON NO.) _____	APPROVED BY (Print name, grade, organization, AUTOVON NO.) _____	SIGNATURE (Print name, grade, organization, AUTOVON NO.) _____
DATE _____	DATE _____	DATE _____

ACTION TAKEN:

CORRECTION CHANGE WILL BE REFLECTED IN _____

NON-CORRECTION AND COMMENT

MATTER REFERRED TO THE FOLLOWING ORGANIZATION FOR REPLY:

APPROVED BY (Print name, grade, organization, AUTOVON NO.) _____

DATE _____

Name: _____

SSN: _____

USING MANUALS Examinee ID # _____
QUESTION AND ANSWER FORM

TRUCK (circle one): 998 923

1. You are ordering a tail light for an M998, and need to look up the SMR code.

A) the authorized echelon for repair and disposition of the part is:

B) the TM Number is: _____

C) the page number(s) is/are: _____

2. You want to order a rear shock absorber for an M998.

A) the SMR code is: _____

the FSCM is: _____

the Part Number: _____

the Usable On Code: _____

B) the TM Number is: _____

C) the page number(s) is/are: _____

3. You are getting ready to work on the exhaust system of an M998. You want to first look up the safety precautions for working around exhaust gases.

A) the symptoms for exhaust poisoning are: _____

B) the TM Number is: _____

C) the page number(s) is/are: _____

4. You have been instructed to adjust the transfer case shift rod of an M998. You have just engaged the parking brake and placed the transmissio shift lever in "D"(Drive).

A) what should you do next? _____

B) the TM Number is: _____

C) the page number(s) is/are: _____

5. You are preparing to torque the lugnuts on an M998.

A) how tight, and in what pattern, should you torque the lugnuts?

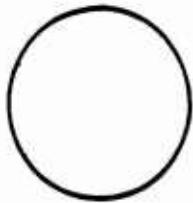

B) the TM Number is: _____

C) the page number(s) is/are: _____

6. You have determined that the transmission oil cooler hoses on an M998 must be replaced.

A) the echelon authorized to replace these hoses is:

B) the TM Number is: _____

C) the page number(s) is/are: _____

JOB KNOWLEDGE TEST

The job knowledge test (JKT) was developed to be parallel in test content to the hands-on test. That is, for each task tested in the hands-on format, the same task was tested in a paper-and-pencil format. The JKT items were based on performance and used extracts from manuals and other pictures to illustrate the task situation. The test was composed of 143 multiple-choice questions that required about an hour and a half to complete.

Although the JKT was pretested to identify poor items, a few items remained in the final version that had inadequate measurement properties. These items were deleted from further analysis. Several other items were ambiguous, so multiple response alternatives were considered correct. Table 1 notes the affected items and reports the correct response alternative for each item.

Table 1. Answer key for the job knowledge test

Correct Item response	Correct Item response	Correct Item response	Correct Item response	Correct Item response	Correct Item response	Correct Item response	Correct Item response		
1	A	30	D	59	C	88	B	117	C
2	C	31	A	60	C	89	C	118	B
3	D	32	A	61	B	90	A	119	C
4	C	33	D	62	A	91	A	120	D
5	A	34	A	63	D	92	B	121	B
6	B	35	A	64	C	93	A	122	A
7	D	36	B	65	B or D	94	C	123	C
8	B	37	D	66	A or D	95	B	124	C
9	C	38	B	67	A	96	B	125	B
10	A or C	39	D	68	C	97	D	126	D
11	B	40	B	69	C	98	B	127	A or B
12	A	41	B	70	A	99	C	128	D
13	D	42	C	71	C	100	C	129	B
14	B	43	A	72	B	101	B	130	A
15	D	44	B	73	A	102	C	131	A
16	B	45	B	74	D	103	D	132	D
17	C	46	C	75	B	104	B	133	D
18	D	47	D	76	dropped	105	B	134	C
19	C	48	B	77	A	106	C	135	D
20	D	49	D	78	B	107	C	136	C
21	A	50	C	79	A	108	D	137	D
22	B	51	A	80	C	109	D	138	C
23	D	52	B	81	D	110	C	139	C
24	D	53	B	82	D	111	C	140	D
25	A	54	D	83	C	112	B	141	D
26	D	55	D	84	A	113	C	142	C
27	B	56	B	85	B	114	B	143	A
28	D	57	B	86	D	115	A	144	D
29	A	58	B	87	D	116	D	145	B

KNOWLEDGE TEST: MOS 3521

Directions

Each item in this booklet consists of a question or statement followed by four answer choices. Only one of the choices correctly answers the question or completes the statement. Read each item. Decide which of the choices you think is correct and blacken the letter on your answer sheet that matches that letter and item number. Here is an example:

1. What game is played in the Superbowl?

- A. Baseball
B. Basketball
C. Football
D. Volleyball

SAMPLE ANSWER SHEET

1. (A) (B) ● (D)

Since football is played in the Superbowl, the answer is C. On the SAMPLE ANSWER SHEET shown above, C has been filled in. Be sure to fill in only one letter for each item on your answer sheet.

Do not spend too much time on any one item. This test has six sections which cover five military vehicles and general mechanical knowledge. If you are not familiar with one of the vehicles, you may continue on to the next section. Remember to go back to the unfinished section in the time you have remaining. Try to answer every item. Even if you are not sure of your answer, make the best guess you can. Mark only one choice for each item, and be sure the item you mark on your answer sheet matches the item number in the booklet.

M923 5-TON VEHICLE

The following 2 questions refer to the figure below.

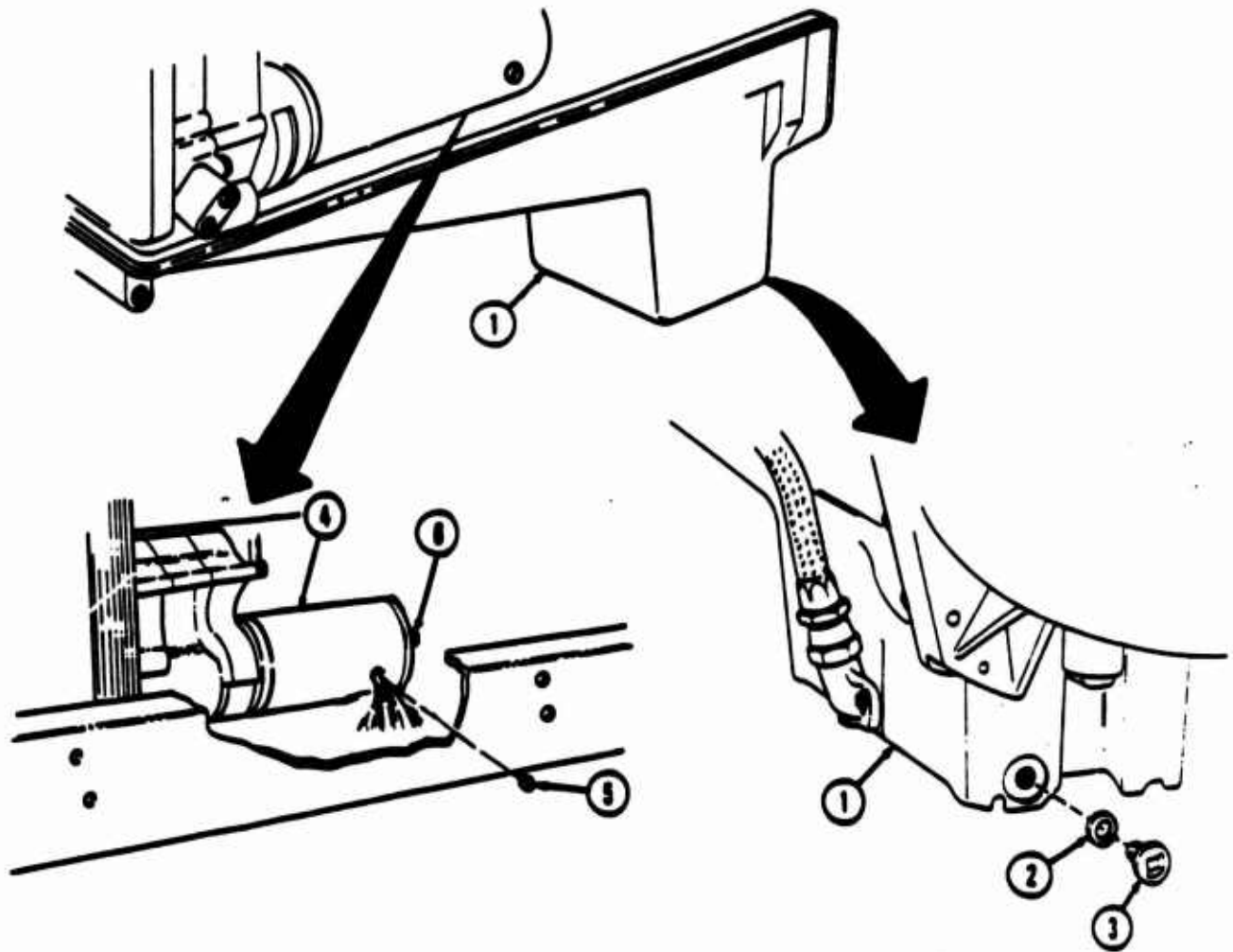

1. You are changing the oil and oil filter on an M923. To allow the old oil to drain out, which part do you remove first?
 - A. 3
 - B. 5
 - C. 4
 - D. 6

2. You are changing the oil and filter on an M923 and servicing the oil filter shell. You have already drained the oil from the crankcase. Which part do you remove next?
- A. 2
 - B. 4
 - C. 5
 - D. 6
3. You are servicing the oil filter shell. You should clean parts with
- A. a clean, damp rag.
 - B. compressed air.
 - C. detergent.
 - D. dry cleaning solvent.

The following 3 questions refer to the figure below.

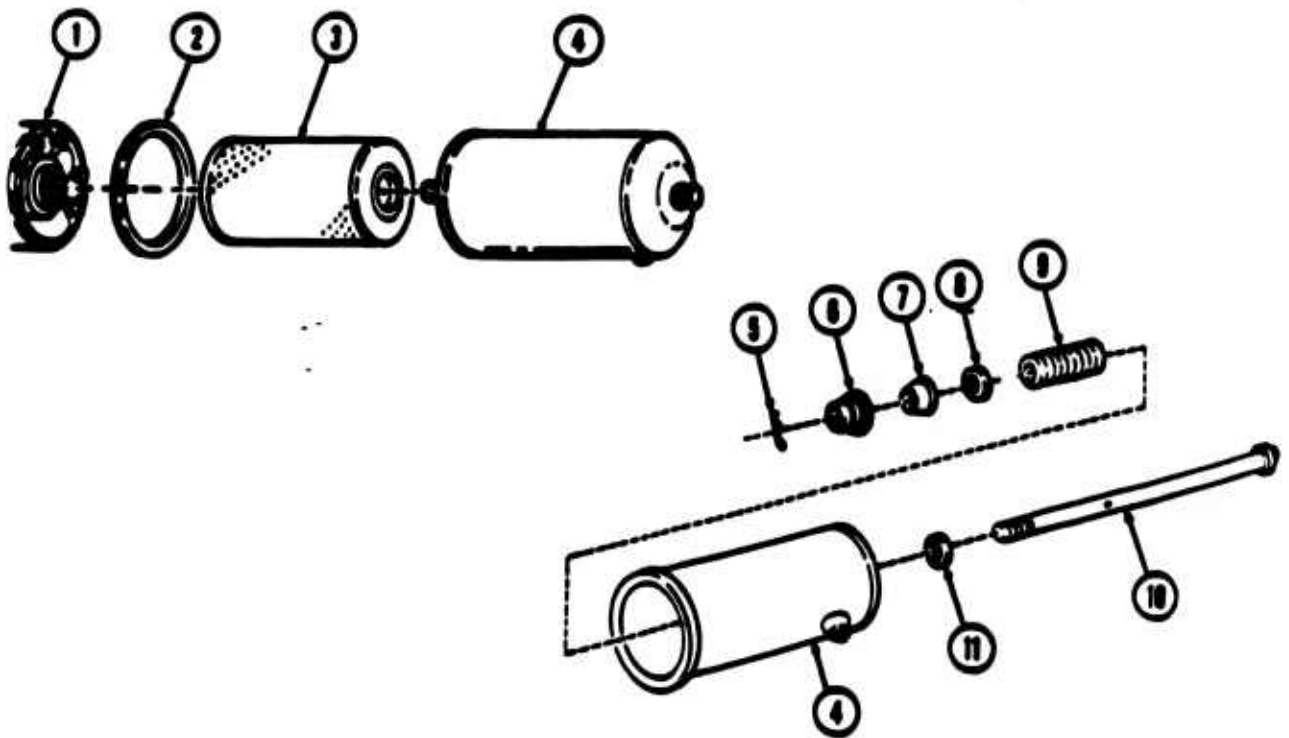

4. You are changing the oil and filter on an M923 and servicing the oil filter shell. You have already drained the oil and disassembled the oil filter shell. Which parts should you clean with solvent before installing the oil filter?
- A. 1 and 4
 - B. 11 and 10
 - C. 4 and 10
 - D. 1 and 2
5. As you are servicing the oil filter, which parts do you inspect for cracks?
- A. 1, 6, and 9
 - B. 2, 3, and 10
 - C. 1, 7, and 8
 - D. 4, 5, and 11
6. You have serviced the oil filter shell and are ready to put the parts back together. Which parts do you throw away and replace with new parts?
- A. 3, 8, and 11
 - B. 2, 3, and 11
 - C. 2, 3, and 5
 - D. 3, 5, and 8
7. You are servicing the oil system of the M923. What should you do with the old paper oil filter element?
- A. Wash it in solvent and then re-use it.
 - B. Drain it, wash it and then re-use it.
 - C. Re-fill it with clean oil and then re-use it.
 - D. Drain it and then throw it away.

8. What should you do with the engine oil pan drainplug gasket after you have removed it from the drainplug?
- A. Clean it off and reinstall it.
 - B. Replace it with a new one.
 - C. Coat it with old engine oil.
 - D. File off any nicks and reinstall it.
9. You should not drain engine oil when the engine is hot because
- A. engine oil is more flammable when hot.
 - B. engine oil flows more quickly when cold.
 - C. you want to avoid injury to yourself.
 - D. your tools might stick to the hot drain pan.
10. To avoid spilling oil while draining the engine oil filter shell you should place a
- A. funnel under the oil filter.
 - B. rag under the oil filter.
 - C. drip can under the oil filter.
 - D. pile of absorbent on the ground.

11. While servicing the oil system and using dry cleaning solvent, you should ensure that the area
- (1) is enclosed with no wind.
 - (2) is well ventilated.
 - (3) has no open flames.
 - (4) is maintained at a temperature between 50° F and 70° F.
- A. 1 and 3
- B. 2 and 3
- C. 2 and 4
- D. 1 and 4
12. You have just cleaned the oil filter shell of an M923 with drycleaning solvent. To dry it, you should
- A. blow compressed air at a maximum of 30 psi.
- B. allow it to air dry.
- C. blow compressed air at a maximum of 45 psi.
- D. place it in front of a fan.
13. Before installation, you should coat the oil filter gasket of an M923 with a light coat of
- A. GAA.
- B. WD40.
- C. drycleaning solvent.
- D. engine oil.

14. What should you wear while cleaning with compressed air?
- A. rubber gloves
 - B. eye protection
 - C. ear protection
 - D. respirator
15. If the M923 starts but fails to keep running, the first step you should take is to
- A. check for proper battery voltage output.
 - B. drain some fuel and check it for contamination.
 - C. check for proper fuel pump pressure, at the engine block.
 - D. check the air restriction indicator.
16. Assume that you have just cleared an obstructed fuel line that prevented the M923 from running after it was started. After reconnecting the fuel line, your next step should be to
- A. drain the fuel tank.
 - B. prime the fuel system.
 - C. clean the fuel filter.
 - D. reconnect the batteries.
17. To clear an obstructed fuel line on the M923, you should use either sturdy wire or
- A. water delivered under high pressure.
 - B. string.
 - C. compressed air.
 - D. a small diameter bolt.

18. To check the air restriction indicator on an M923 you should be
- A. on the left side of the vehicle at the air filter housing.
 - B. in the cab looking under the dash panel.
 - C. under the left side of the vehicle at the air tanks.
 - D. in the cab looking on the dash panel.
19. To reset the air cleaner indicator on an M923 you should
- A. tap it with a wrench.
 - B. turn the dial scale to zero.
 - C. press down on the button on the top of the indicator.
 - D. adjust the indicator with a #1 Phillips screwdriver.
20. To check fuel for contamination on an M923 you should
- A. measure the fuel pump output pressure.
 - B. look to see if light passes through the fuel filter element.
 - C. look in the fuel tank for signs of sediment.
 - D. open draincock at fuel filter and drain fuel into a glass container.

21. You have been told to check the battery voltage on an M923 using a STE/ICE. Your first task is to connect the DCA cable to the VTM. (Refer to the VTM picture.) Where do you connect the cable on the VTM?

- A. 1
- B. 2
- C. 3
- D. 7



DCA Cable

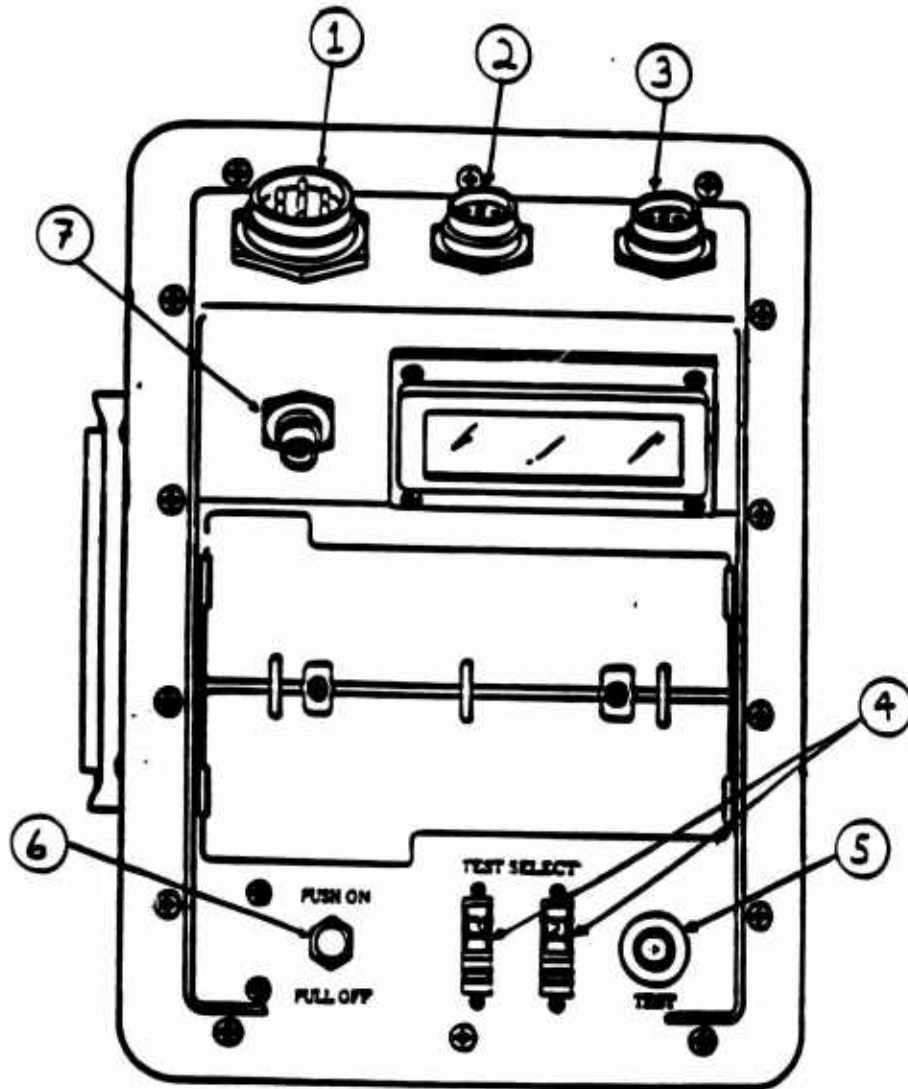

Vehicle Test Meter (VTM)

22. You are checking the battery voltage on an M923 using a STE/ICE. You have connected the DCA cable to the VTM. Next, you must connect the DCA cable to the truck. (Refer to the VTM picture and the TM extract below.) When you connect the cable
- A. 4 must read zero.
 - B. 6 must be OFF.
 - C. 6 must be ON.
 - D. 3 must be connected to the truck.

2-3-3. VTM POWER UP (cont)

2-3-3

8. POWER UP - DCA MODE

In the DCA mode, the VTM receives its power from the W1 cable connected to the vehicle/equipment.

CAUTION

Do not connect VTM to diagnostic connector while VTM power switch is on. Damage to connectors may result.

Connect DCA cable W1 to J1 DCA/PWR on VTM before connecting to the vehicle/equipment diagnostic connector. Otherwise, damage to connector may result.

Do not connect or disconnect VTM while vehicle/equipment is operating. Damage to connector may result.

WARNING

On vehicles with a master switch in the negative (-) battery cable, sparking may occur if the VTM case touches the vehicle while master switch is off and VTM is on. Sparking in the presence of fuel or fuel vapors presents a potential hazard. Avoid hazard by doing all testing with the vehicle master switch on.

23. You are checking the battery voltage on an M923 using a STE/ICE. You have connected the DCA cable to the VTM. Next, you must connect the DCA cable to the DCA connector on the truck. Where should you go to connect the cable?

- A. The left side of the engine
- B. The cab on the driver's side
- C. The battery box connector
- D. The cab on the passenger's side

24. You are checking the battery voltage on an M923 using a STE/ICE. You have connected the DCA cable to the VTM and to the truck. Next, you connect the test probe cable to the VTM. (Refer to the VTM picture.) Where do you connect the cable?

- A. 1
- B. 2
- C. 3
- D. 7



Test Probe Cable

25. You are checking the battery voltage on an M923 using a STE/ICE. You have connected the DCA cable to the VTM and to the truck. You have connected the test probe cable to the VTM. The VTM power and the truck battery switch are on. (Refer to the TM extract below.) What do you do before connecting the test probe to the batteries to run the voltage test?
- A. Run a confidence test.
 - B. Turn the VTM off.
 - C. Start the engine.
 - D. Set the TEST SELECT switches to #89.

2-3-33. DC VOLTAGE 0 TO 45 VDC TEST #89

2-3-33

Description:

This procedure measures voltage in the range of -45 to +45 volts. The VTM is used as a DC voltmeter with the decimal point in the correct position. This test must be done with the component being tested turned on.

Typical Applications:

Battery Coil Primary
 Fuel Solenoid Starter Motor
 Starter Solenoid Starter Cable Drop
 Alt/Gen Output
 Alt/Gen Negative Cable Drop
 Any DC voltages within -45 to +45

References:

Vehicle/Equipment TM

Pre-Test Procedures:

<u>Procedure</u>	<u>Ref</u>
Run confidence test	2-2-3

Possible Error Messages:

E005 Offset not performed

Control Functions:

01, 02, 03, 04, 05, 06

26. You are checking the battery voltage on an M923 using a STE/ICE. You are ready to hook the test probe cable clips to the battery terminals. (Refer to the figure below.) Where do you attach the clips?

- A. red clip to 3; black clip to 2
- B. red clip to 2; black clip to 4
- C. red clip to 3; black clip to 1
- D. red clip to 1; black clip to 4

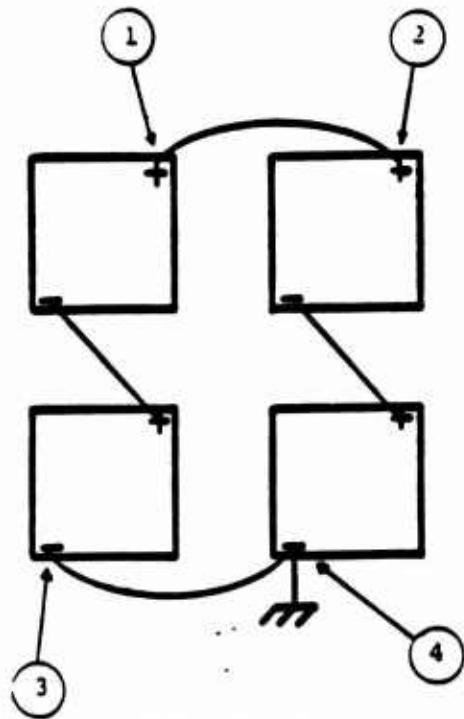

M923 Batteries

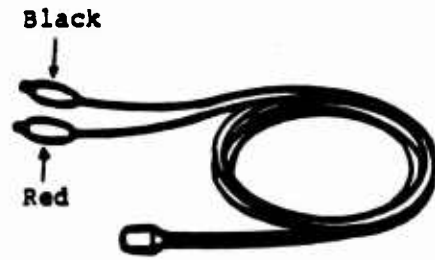

Test Probe Cable

27. You have completed the battery voltage test on an M923 using a STE/ICE. Which of the following readings indicates that you performed the test correctly?

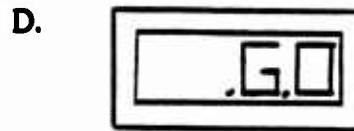

28. Before using the STE/ICE to troubleshoot a problem on the M923, you must first

- A. disconnect the battery ground cables.
- B. support the rear of the vehicle on jackstands.
- C. perform a battery voltage test.
- D. make sure the STE/ICE has been calibrated.

29. Assume that you are replacing the neutral start switch of the M923. After removing the wires from the neutral start switch, what should you do next?
- A. Tag the wires for reinstallation.
 - B. Connect the wires to the wiring harness on the left side of the transmission.
 - C. Remove the engine breather tube.
 - D. Cover the exposed wire leads, to prevent them from shorting against the frame.
30. After you have reinstalled and tightened the neutral start switch on the M923, what should you do next?
- A. Torque the switch to specifications.
 - B. Reconnect the battery ground cables and check the operation of the switch.
 - C. Reconnect the engine breather tube.
 - D. Reconnect the wires to the switch.
31. After you have reinstalled the neutral start switch on the M923, and reconnected the wires and retainer shift linkage, what should you do next?
- A. Reconnect the battery ground cables and check the operation of the switch.
 - B. Adjust the movement of the linkage.
 - C. Torque the switch to specifications.
 - D. Disconnect the battery ground cables.

32. After removing the metric locknut from the left side of the M923 transmission you should
- A. discard it.
 - B. inspect it, and re-use it only if it appears serviceable.
 - C. coat it with oil.
 - D. replace it with a standard locknut.
33. To remove the neutral start switch from the M923 you should first
- A. drain the transmission fluid.
 - B. disconnect the shift cable.
 - C. ensure that the vehicle is in neutral.
 - D. disconnect the negative battery cables.
34. You are installing the neutral start switch in the M923 transmission. You should not
- A. overtighten the switch.
 - B. replace lost transmission fluid.
 - C. replace the engine breather tube.
 - D. install a new metric locknut.
35. To remove the neutral start switch you should use
- A. an open-end wrench.
 - B. a crowfoot wrench with ratchet.
 - C. an adjustable wrench.
 - D. a socket and ratchet.

LVS - LOGISTICAL VEHICLE SYSTEM

The following 9 questions refer to TM 9-2320-297-20, pages 2-282 to 2-290 in the handout.

You are troubleshooting a malfunctioning hydraulic low oil level alarm and light on an LVS.

36. The LTI says that the alarm works but the light does not. You should first check
- A. the serviceability of the sending unit breather tube between the alarm and the light.
 - B. the warning light bulb for a broken filament.
 - C. for grounded wiring between the light bulb and the alarm.
 - D. for voltage between the alarm and the warning light.
37. The LTI says that neither the alarm nor the light works when the ignition is first turned on. You should check
- A. the serviceability of the sending unit breather tube between the alarm and the light.
 - B. the warning light bulb for a broken filament.
 - C. for grounded wiring between the light bulb and the alarm.
 - D. for voltage between the alarm and the warning light.

38. To test for functioning of the alarm and light, you should first test for continuity at the hydraulic oil level sender, located on the picture below by the letter _____.

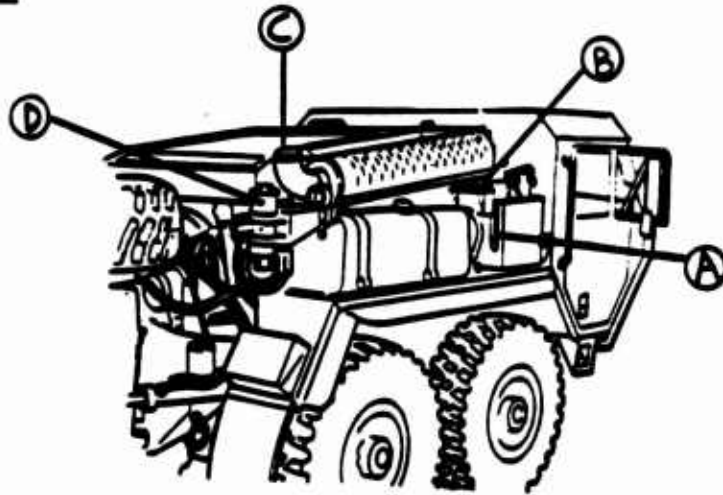

39. You know that the light works. However, you find no voltage at the terminal of the alarm. You should repair/replace the
- A. wiring between the alarm and warning light.
 - B. sending unit harness plug.
 - C. warning alarm relay.
 - D. wiring between the alarm and bulb socket.
40. The LTI says that the alarm does not work but the light does. You should check
- A. the serviceability of the sending unit between the alarm and the light.
 - B. for voltage at terminal of the alarm.
 - C. for continuity at terminal of alarm and light.
 - D. the warning alarm relay.

41. Assume that you have finished Test 10 and found no voltage. The next test you should conduct is
- A. a continuity test at a relay in the cab.
 - B. a voltage test at a relay in the cab.
 - C. a continuity test at the alarm and light socket.
 - D. a voltage test at the alarm and light socket.
42. Assume that you have finished Test 10 and read 23.8 volts on the multimeter. The next test you should conduct is
- A. a continuity test at a relay in the cab.
 - B. a voltage test at a relay in the cab.
 - C. a continuity test at the alarm and light socket.
 - D. a voltage test at the alarm and light socket.

The following 2 questions refer to the figure below.

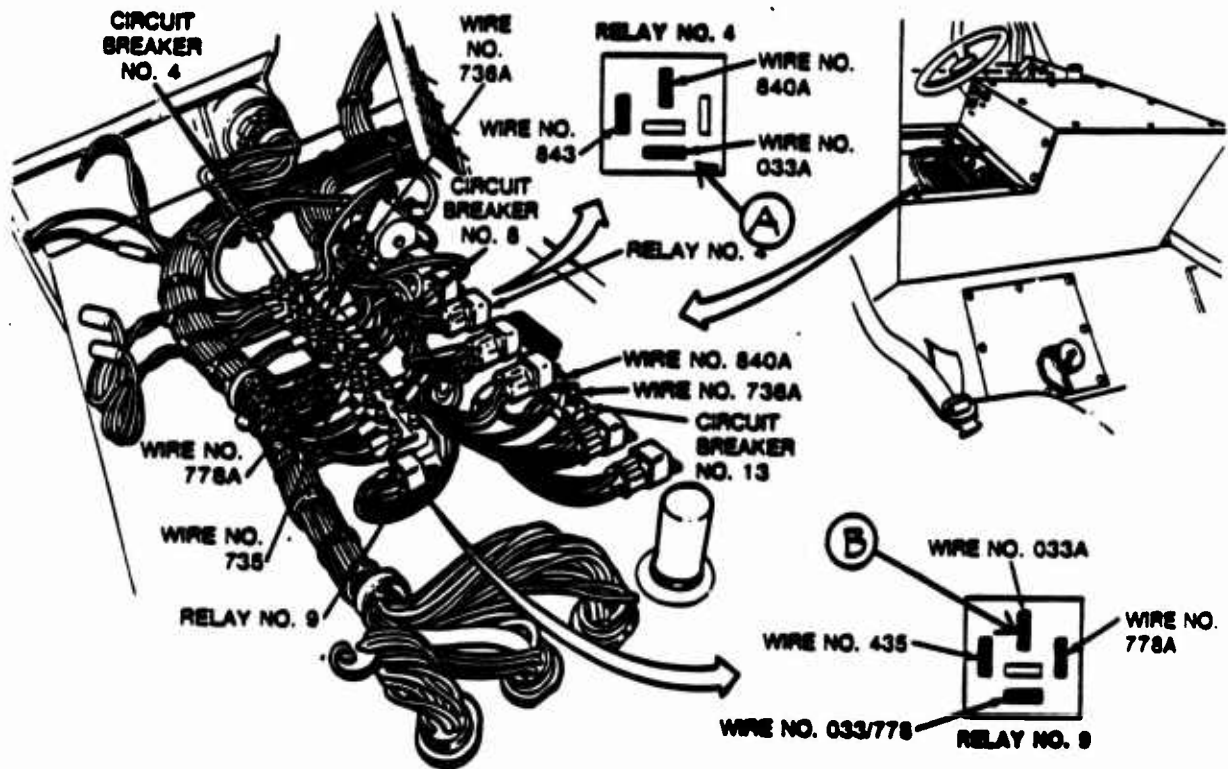

43. You have decided to conduct Test 18. The outcome which would cause you to continue to Test 19 is
- A. no voltage at wire A.
 - B. 24 volts at wire A.
 - C. no voltage at wire B.
 - D. 24 volts at wire B.

44. You have decided to conduct Test 18. The outcome which would cause you to replace wire 033A is
- A. more than 26.8 VDC at wire A.
 - B. 24 volts at wire A.
 - C. more than 26.8 VDC at wire B.
 - D. 24 volts at wire B.
45. You are to drain the radiator of the LVS. What should you do after you push down on the radiator cap?
- A. Wait ten full minutes and then remove the cap.
 - B. Turn one half turn counterclockwise and release pressure.
 - C. Turn one half turn clockwise and release pressure.
 - D. Turn a half turn and remove the cap.
46. What is the correct order of actions you should take to replace the coolant filter on an LVS?
- (1) Close two valves on coolant filter adapter.
 - (2) Position filter and turn one quarter turn clockwise.
 - (3) Coat filter seal on new filter with clean engine oil.
 - (4) Turn filter counterclockwise using a filter wrench.
- A. 1, 4, 2, 3
 - B. 3, 2, 4, 1
 - C. 1, 4, 3, 2
 - D. 4, 1, 3, 2

47. To service the radiator of an LVS, you should use _____ to fill the radiator and fill it to the level of _____.

	<u>Use</u>	<u>Fill to</u>
A.	coolant	the top of the fillerneck
B.	coolant and water	the top of the fillerneck
C.	coolant	one half inch below the fillerneck
D.	coolant and water	one inch below the fillerneck

48. When you begin to service the radiator of an LVS, you should first inspect all hoses for

- (1) wear.
- (2) tightness.
- (3) leaks.
- (4) blockage.

- A. 1, 2 and 4
- B. 1, 2, and 3
- C. 1, 3, and 4
- D. 3 and 4

49. What is the correct sequence of steps for servicing the radiator?

- A. Drain coolant from radiator and engine block, fill radiator, replace coolant filter.
- B. Replace coolant filter, drain coolant from radiator, drain coolant from engine block.
- C. Drain coolant from engine block, drain coolant from radiator, replace coolant filter, fill radiator.
- D. Drain coolant from radiator, drain coolant from engine block, replace coolant filter, fill radiator.

The following 2 questions refer to the figure below.

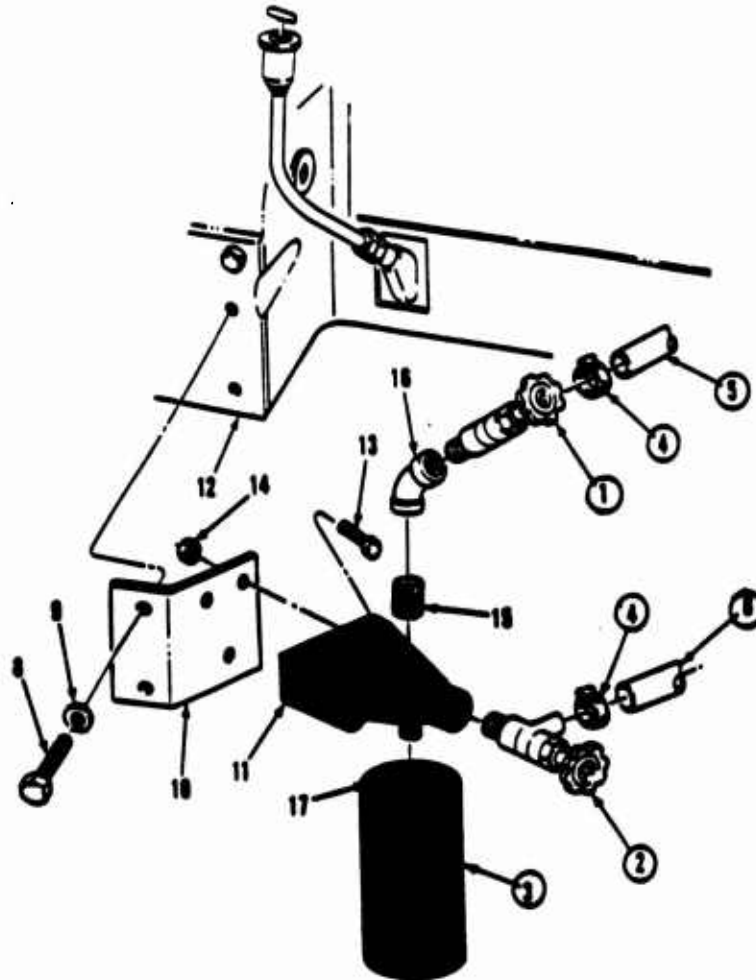

50. After you have closed the valves 1 and 2, and turned the filter by hand to remove it, the next step you should take is to
- A. turn part 3 counterclockwise with a filter wrench.
 - B. turn parts 1 and 2 clockwise to open.
 - C. loosen part 4 and plugs 5 and 6.
 - D. tighten part 5 and plugs 4 and 6.

51. When you have removed part 3, you should
- A. discard it and install a new part.
 - B. inspect it and reuse it only if it appears serviceable.
 - C. discard it, install a new part, and torque it to specifications.
 - D. clean it and reinstall it.
52. While working on the radiator and coolant filter, you should take care to
- A. wear protective footwear.
 - B. wear gloves if the system is hot.
 - C. remove jewelry to avoid electrical shock.
 - D. wear a cover to avoid burning your head on the exhaust pipe.

For the next 7 questions refer to TM 9-2320-297-20, pages 2-485 to 2-489 in the handout.

You must troubleshoot to find the cause of a malfunctioning folding boom on the LVS.

53. You have applied the parking brake and pulled out the shift selector valve. What should you do next?
- A. Check position of auxiliary hydraulics valve.
 - B. Look at the level on the hydraulic reservoir.
 - C. Operate the folding boom in the REMOTE position.
 - D. Operate the folding boom in the MANUAL position.

54. After setting the MANUAL/REMOTE switch to MANUAL, you find that the boom doesn't operate. Next, you should

- A. rotate control A clockwise.
- B. push control B in.
- C. check to ensure valve C is in the AUXILIARY HYDRAULICS position.
- D. check control D for free movement.

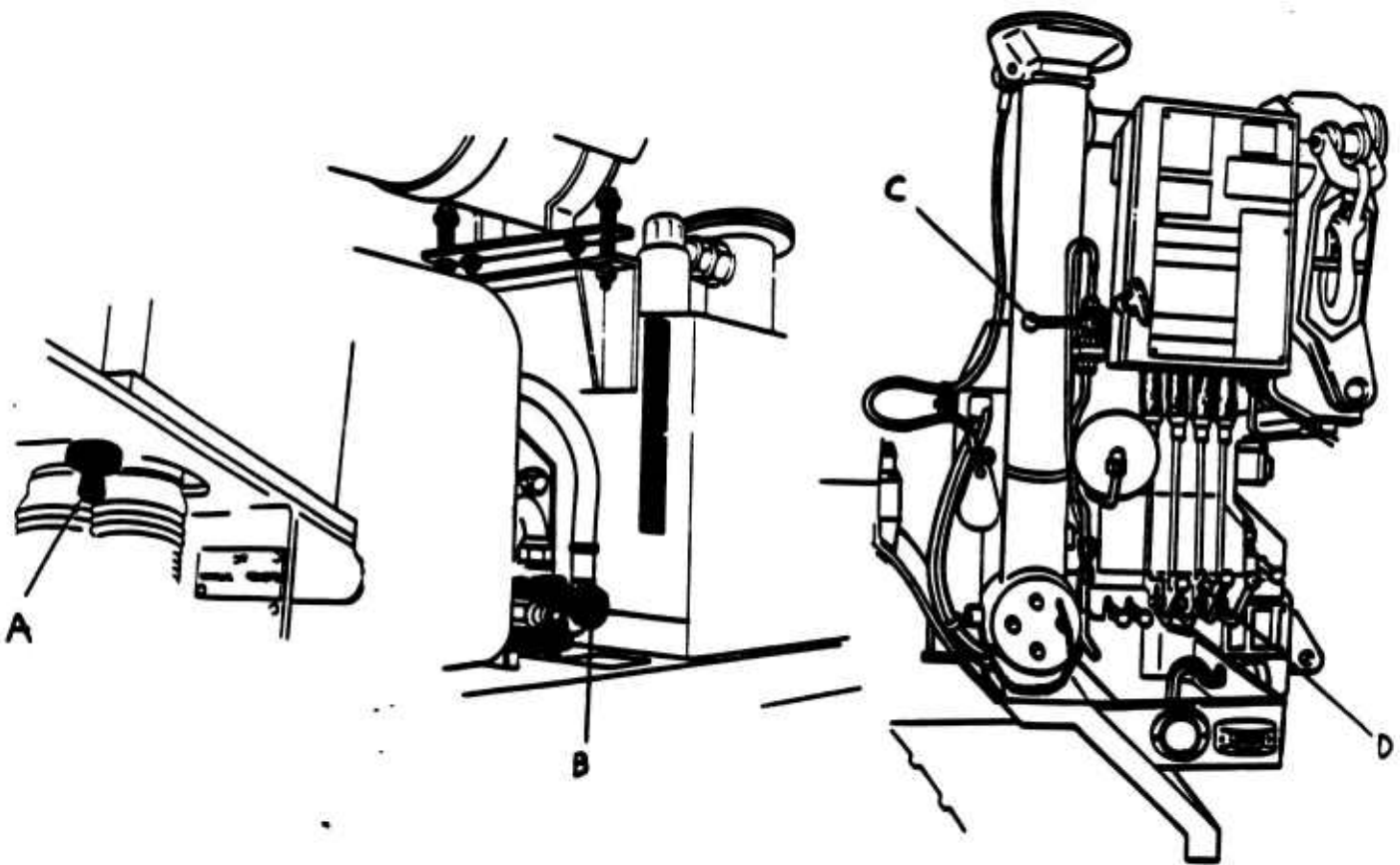

55. Assume that the FOLDING BOOM control operates smoothly. Your next actions should be to

- (1) reduce any excess load on boom.
- (2) check for restrictions in hydraulic lines.
- (3) check to see if folding boom moves upward.
- (4) install a pressure gage at main control valve.

- A. 1 then 4
- B. 2 then 1
- C. 1 then 3
- D. 1 then 2

56. After you find no binding or obstructions in the hydraulic lines, you should

- A. install a pressure gage at A.
- B. install a pressure gage at B.
- C. check crane relief pressure at C.
- D. check crane relief pressure at D.

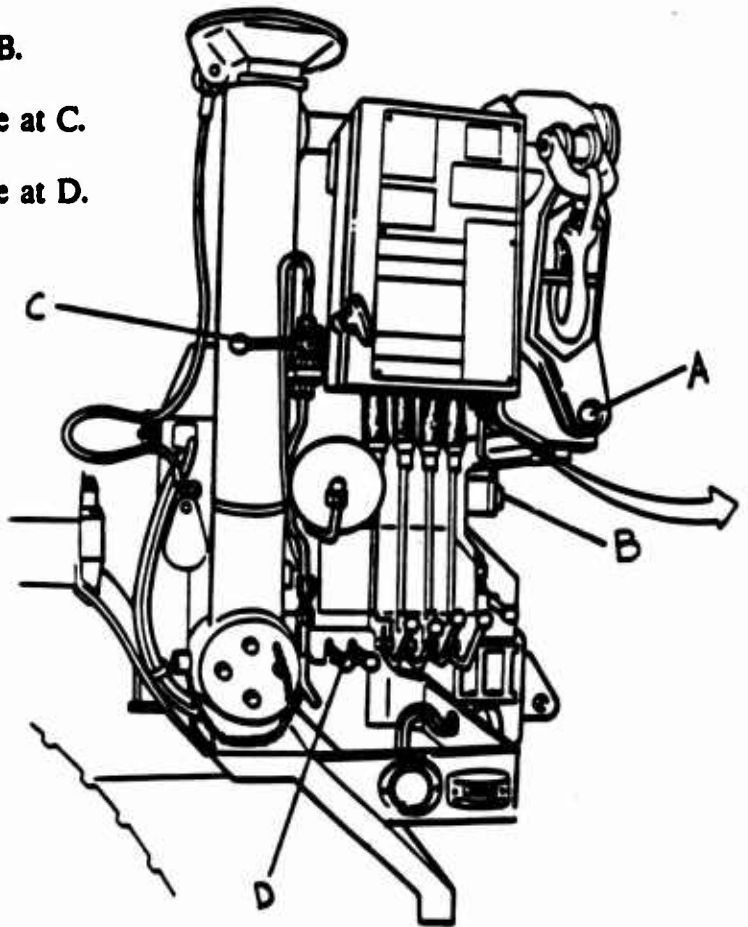

57. You discover that the boom will not operate because the load is excessive. After removing the cargo, what actions should you take next?

- (1) Check for binding/restrictions at the cylinder or lines.
- (2) Try to move the boom downward.
- (3) Try to move the stabilizer legs outward.
- (4) Check to see if the air pressure is within specifications.

- A. 1, 2, and 3
- B. 1 and 2
- C. 2 and 3
- D. 1 and 4

58. At Test 6 you have found no restrictions in the hydraulic lines and no damage at the cylinder. The boom is halfway extended but will not move up or down. What sequence of steps should you take next?

- (1) Install a pressure gage at test port.
- (2) Run the engine.
- (3) Operate boom control lever to raise boom.
- (4) Operate boom control lever to lower boom.

- A. 1, 2, then 4
- B. 1, 2, then 3
- C. 1, then 2
- D. 1, 3, then 4

59. Assume you are at Test 8 and read a pressure of 2,850 psi. You should next

- A. adjust the crane relief pressure.
- B. check the auxiliary selector relief setting.
- C. check the crane relief pressure.
- D. operate the boom to check for free travel.

For the next 4 questions refer to TM 9-2320-297-20, pages 2-429 to 2-434 in the handout.

You are troubleshooting to find what is causing the winch to malfunction.

60. To get a true reading at Test 3, you must first
- A. set shift selector in NEUTRAL.
 - B. ensure hoses and fittings are primed.
 - C. set ignition switch to ON.
 - D. ensure hydraulic oil has been added to reservoir.
61. You have attached the remote control unit in order to test connector MC21. What outcome(s) would send you to Test 6?
- (1) 24 volts on wire 681 pin No. 3.
 - (2) 20 volts on pin No. 4.
 - (3) 20 volts on wire 681 pin No. 3.
 - (4) 26 volts on pin No. 4.
- A. 1 and 4
 - B. 2 and 3
 - C. 3
 - D. 2
62. To check functioning of the winch OUT switch, you should first check (Refer to wiring figure in the manual excerpt.)
- A. wire 1 and then wire 2.
 - B. wire 3 and then wire 4.
 - C. wire 2 and then wire 1.
 - D. wire 4 and then wire 3.

63. You have determined that voltage is getting to the winch OUT switch. To test whether voltage is getting to the winch IN switch, you should test

- A. 5.
- B. 6.
- C. 12.
- D. 11.

64. Before you begin Test 3, you should

- (1) check that the hydraulic lines are not leaking or damaged.
- (2) turn on the ignition switch.
- (3) make sure other people are clear of the vehicle.
- (4) set the ignition switch to ON.

- A. 4
- B. 1 and 2
- C. 1 and 4
- D. 1, 2, and 3

65. When you have found the fault that prevented the winch from operating properly, you should

- A. take the shift selector out of neutral.
- B. reinstall protective caps on hydraulic fittings.
- C. flush the hydraulic system.
- D. turn off the ignition switch.

66. Assume you have just conducted Test 3 and read 22.9 volts on the multimeter. What should your next step be?
- A. Take off the top cover of the remote control and conduct a voltage test on the winch OUT switch.
 - B. Conduct a voltage check at pin No. 4 while holding the winch IN button.
 - C. Connect the remote control to Connector MC21.
 - D. Test pin No. 3 and pin No. 4 on wire 681.
67. Assume that you got a reading of 22.9 volts at wire 840 on terminal NC1 of winch OUT switch. (Refer to wiring diagram in the TM excerpt.) Next, you should
- A. conduct a voltage test at wire 2.
 - B. conduct a voltage test at wire 7.
 - C. test voltage on terminal No. 3 of winch OUT switch.
 - D. test voltage on terminal NC2 of winch IN switch.

M998 (HMMWV VEHICLE)

68. When replacing the runflat assembly of the M998, what should you do with the wheel weights on the wheel?
- A. Tape them in place on the wheel in case they get moved during the job.
 - B. Remove them and mark their locations, then reinstall the same weights after the job is done.
 - C. Remove and discard them.
 - D. Add new weights before beginning the job, making sure that the new weights are in the exact same positions as the old ones.
69. Which answer best describes what you should do with the locknuts that you take off of the runflat halves of the M998?
- A. Discard them and install new locknuts.
 - B. Inspect them, and reuse them only if they appear serviceable.
 - C. Discard them, install new locknuts, and torque the new locknuts to specifications.
 - D. Discard them, and replace them with lockwashers and regular (non-locking) nuts.
70. When reassembling the runflat assembly of the M998, what should you do just before lowering the tire over the rim half?
- A. Center the runflat assembly in the tire.
 - B. Center the O-ring seal on the rim half.
 - C. Bolt together the two rim halves, and torque the 8 nuts to specifications.
 - D. Secure the grease packets to the runflat halves, using filament tape.

71. When reassembling the runflat assembly of the M998, where should the grease packets be installed?
- A. Between the rim and the runflat half, centered on the split between the two runflat halves.
 - B. Between the runflat and the hub, centered on the split between the two runflat halves.
 - C. Between the runflat and the tire, centered on each runflat half.
 - D. Between the rim and the runflat half, centered on each runflat half.
72. When replacing the runflat assembly of the M998, you should orient the notches on the runflat halves so that
- A. they are on opposite sides of the wheel from one another.
 - B. they are on the same side of the wheel.
 - C. they face outward, toward the tire.
 - D. they face inward, toward the rim.
73. When disassembling the runflat assembly of the M998, what must you do before removing the runflat halves from the tire?
- A. Remove the 4 nuts and bolts that secure the runflat halves together.
 - B. Lubricate the tire to make removal of the runflat assembly easier.
 - C. Rotate the runflat assembly 90 degrees, so that you can pull it out of the tire.
 - D. Remove the grease packets from the runflat halves.

74. What should you do with a grease packet that has been removed from a flat M998 tire?
- A. Inspect it and reuse it only if it is serviceable.
 - B. Test it for punctures and reuse it.
 - C. Clean it and reuse it.
 - D. Discard it.
75. When reassembling the runflat assembly of the M998, which of the following should you not do?
- A. Use both double- and single-sided adhesive tape to secure the grease packets.
 - B. Bolt together the two runflat halves before installing them in the tire.
 - C. Torque the locknuts using a crowsfoot wrench.
 - D. Attach grease packets before installing the runflat halves in the tire.
76. When reassembling the wheel and runflat assembly of the M998, you find a paint dot on the tire sidewall. You should
- A. align it with the valve stem.
 - B. align 180 degrees away from the valve stem.
 - C. align it with the wheel weight(s).
 - D. align it with the valve stem on the opposite side of the tire.

77. What is the first step in checking and adjusting the toe in/out on the M998?
- A. Checking tires for uniform tread wear.
 - B. Driving the vehicle and checking for unusual handling.
 - C. Moving the vehicle forward, then backward, to settle the suspension.
 - D. Lubricating the front end with a grease gun.
78. Assume that you are preparing to set the toe in/out on the M998. With the vehicle supported on jackstands, you notice more than 3/8" movement at the top of the tires when you move the tire in and out. What should you do next?
- A. Tighten the upper ball joint.
 - B. Replace the upper ball joint.
 - C. Tighten the wheel bearing.
 - D. Replace the wheel bearing.
79. Assume that you are setting the toe in/out on the front wheels of the M998. You have just measured the distance from tire-to-tire, both on the front and on the rear of the tires. The front distance is 2" greater than the rear distance. What does this tell you about the alinement of the vehicle?
- A. There is toe out.
 - B. There is toe in.
 - C. There is zero toe.
 - D. There is negative camber.

80. The toe in/out is adjusted on the M998 by
- A. rotating one of the tie rod adjusting sleeves.
 - B. adjusting the steering box free play.
 - C. rotating both tie rod adjusting sleeves.
 - D. rotating the control arm bushings.
81. To check for wear in the front end components of the M998 before aligning the vehicle, you must
- A. roll the vehicle forward and back.
 - B. turn the steering wheel back and forth several times.
 - C. attempt to rotate the tie rod adjusting sleeves.
 - D. raise the vehicle and support it on jackstands.
82. To check the toe-in on the M998, the vehicle must be parked on a level surface, and
- A. the front end must be supported on jackstands.
 - B. the wheel bearings must be properly adjusted.
 - C. loaded to full operating capacity.
 - D. the wheels must be pointed straight ahead.
83. Before checking the toe in/out of the M998, you should check the geared hubs for output spindle play. This is done by
- A. revving the engine while turning the steering wheel either way.
 - B. attempting to move the tires up and down by hand.
 - C. attempting to move the tires in and out by hand.
 - D. attempting to move the tie rods horizontally and vertically.

84. Assume that you are checking the toe in/out on the M998. After determining and marking the centerpoint on the front side of each of the front tires, what is your next step?
- A. Measure the distance between the two points.
 - B. Measure the distance between the front and rear of each tire.
 - C. Measure the width of each tire.
 - D. Rotate the tires 180 degrees and repeat the procedure on the rear of each tire.
85. After checking the toe in/out on the M998, you discover that the vehicle has too much toe in. To correct this condition you should
- A. shorten the longer of the two tie rods until it is the same length as the other.
 - B. shorten each of the tie rods an equal amount.
 - C. lengthen the longer of the two tie rods until it is the same length as the other.
 - D. lengthen each of the tie rods an equal amount.
86. Which of the following should be done after you have adjusted the toe-in on the M998?
- A. Adjust the steering free play.
 - B. Lubricate the front end with a grease gun.
 - C. Check the tire pressure.
 - D. Check the vehicle for pull or wander.

87. When reconnecting the propeller shaft to the parking brake rotor of the M998, which of the following should you definitely not do?
- A. Touch the clean surface of the parking brake rotor.
 - B. Replace the used lockwashers with new ones.
 - C. Support the weight of the rotor with one hand.
 - D. Apply thread locker (such as Loctite) to the capscrews, and reuse the old lockwashers.
88. Assume that you are removing the parking brake cable on the M998. After removing the cotter pin from the slotted nut on the parking brake caliper, what should you do with the cotter pin?
- A. Inspect and reuse the cotter pin if it appears serviceable.
 - B. Discard the used cotter pin and install a new one.
 - C. Straighten the used cotter pin using needlenose pliers then reuse it if it appears serviceable.
 - D. Discard the used cotter pin and install a new clevis pin.
89. Before beginning to replace the parking brake cable on the M998, how must you prepare the vehicle?
- A. Jack up the vehicle and support it on jackstands.
 - B. Steam clean the undercarriage of the vehicle.
 - C. Release the parking brake.
 - D. Place the transmission in gear.

90. Before removing the parking brake cable from the frame of the M998, you must first
- A. remove the clip.
 - B. remove the muffler and heat shield.
 - C. remove the rear propeller shaft completely.
 - D. removing the parking brake rod.
91. After installing the spring on the parking brake caliper of the M998 (see part #14 in diagram), what should you do to the spring?
- A. Crimp the small end.
 - B. Safety wire the ends.
 - C. Check to see that it is expanding properly.
 - D. Crimp the large end.

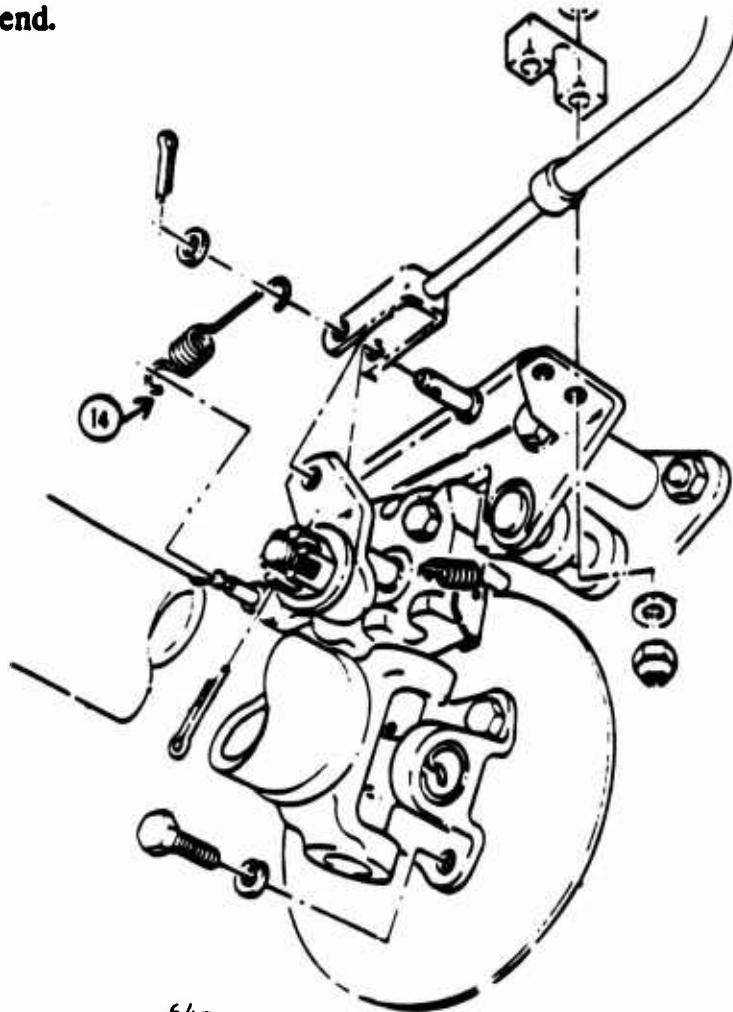

92. After installing a new parking brake cable on the M998, you should
- A. lubricate the cable.
 - B. adjust the parking brake.
 - C. break-in the cable by operating the parking brake several times.
 - D. check the service brakes.
93. When replacing the universal joints of the M998, how should you orient the socket that is driving out the cross from the yoke?
- A. With the open end of the socket toward the vise.
 - B. With the closed end of the socket toward the vise.
 - C. With the socket on its side.
 - D. With the socket covering the grease fitting (zerk) to prevent the fitting from being damaged during removal of the cross.
94. You are removing a universal joint from the driveshaft of the M998. What should you do after pressing the first of the two bearing cups out of the yoke?
- A. Remove the snap ring on the other end of the cross.
 - B. Measure the yoke opening to ensure that it is still parallel and that you have not damaged it.
 - C. Reverse the sockets and press out the other bearing cup.
 - D. Remove the two bearing cups on the exposed ends of the cross.

95. Assume that you are reassembling a universal joint on the M998. To install the first bearing cup into the yoke you should use a
- A. pair of needlenose pliers.
 - B. socket and vise.
 - C. hammer and chisel.
 - D. pair of snapping pliers.
96. When replacing a universal joint on the M998, you should position the grease fitting (zerk) so that it faces
- A. the front of the vehicle.
 - B. toward the yoke.
 - C. the rear of the vehicle.
 - D. away from the yoke.
97. Assume that you are replacing a universal joint on the M998. You have just removed all bearing cups from the cross. What should be your next step?
- A. Remove the snaprings from the yoke.
 - B. Reinstall the snaprings in the yoke.
 - C. Remove the needle bearings from the bearing cups.
 - D. Remove the cross from the yoke.

98. When replacing a universal joint on the M998, what should you do just before pressing the bearing cup into the yoke?
- A. Lubricate the yoke openings.
 - B. Make sure that the bearing cup is properly centered.
 - C. Lubricate the needle bearings.
 - D. Make sure that the cross is properly centered.
99. Before removing the universal joint bearing cups from the yoke of the M998 rear propeller shaft, you must first
- A. position the sockets in the vise.
 - B. apply grease at the grease fitting.
 - C. remove the snaprings.
 - D. remove the grease fitting.

The following 4 questions refer to the TM extract below.

5. EXCESSIVE OIL LOSS OR CONSUMPTION

NOTE

Dark smoke coming from exhaust in conjunction with excessive oil consumption may indicate the engine is burning oil. Report this condition, if noted, to DS maintenance.

- Step 1. Check for oil leaks at oil pan drainplug, oil filter and adapter, oil dipstick tube, oil cooler, oil cooler lines, and fittings. Tighten any loose connections or replace any damaged parts.
- Step 2. Other causes, notify DS maintenance.

END OF TESTING!

100. If you discover that the M998 is leaking oil from the oil cooler line fittings, what should you do first?
- A. Look for additional leaks.
 - B. Notify your supervisor.
 - C. Attempt to tighten the fittings if no parts appear damaged.
 - D. Check the oil level.
101. If you notice dark smoke and excessive oil consumption from the M998, you should
- A. drain and refill the crankcase with oil.
 - B. report the condition to DS maintenance.
 - C. change the oil and filter and continue to monitor the condition.
 - D. try to correct the condition if the vehicle is hard to start.

102. If you notice that the dipstick tube on the M998 is leaking a steady stream of oil, what should you do?
- A. Repair the tube.
 - B. Refer the vehicle to DS maintenance.
 - C. Replace the tube.
 - D. Change the oil.
103. Even though there is no dark exhaust smoke, you notice excessive oil consumption and a loose oil pan drainplug on the M998. What should you do first?
- A. Inspect the drainplug gasket.
 - B. Change to a heavier weight crankcase oil.
 - C. Replace the drainplug and gasket.
 - D. Tighten the drainplug.

M1008 (CUCV) VEHICLE

104. Assume that you are tightening the power steering belt on the M1008. After you have loosened the adjusting bolts, you should next
- A. rotate the pump using the adjusting screw.
 - B. rotate the pump by hand by pulling on the pump body.
 - C. pry the pump gently by wedging a prybar between the pump and the engine block.
 - D. check the belt tension.
105. In order to adjust the power steering belt, which bolts/nuts must be loosened?
- A. 7, 8, 13
 - B. 2, 3, 7, 12
 - C. 12, 13
 - D. 2, 3, 12, 13

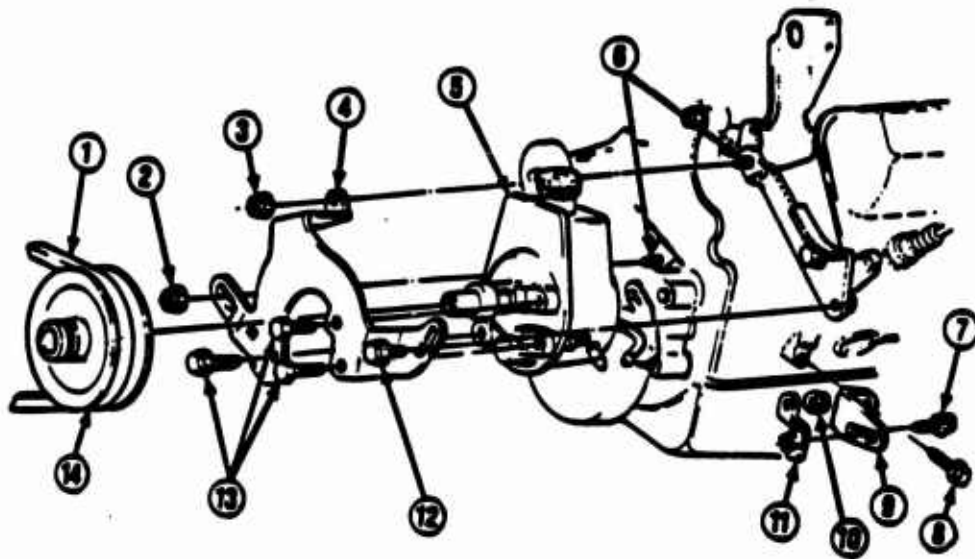

106. You are cleaning the brake shoes of the M1008. You should use
- A. a dry sponge with compressed air.
 - B. a rag soaked with cleaning solvent.
 - C. a wet rag with a soft brush.
 - D. a rag soaked with soapy water.
107. While removing the brake shoe springs of a vehicle what should you wear for safety?
- A. safety shoes
 - B. rubber gloves
 - C. eye protection
 - D. kevlar helmet
108. The name of the proper tool to remove the brake shoe springs is
- A. brake adjusting pliers.
 - B. brake spoon.
 - C. brake adjusting tool.
 - D. brake spring pliers.

M813 5-TON VEHICLE

For the next 8 questions refer to TM 9-2320-260-20-2-1, pages 24-179 to 24-194 in the handout.

The operator of an M813 has told you that both of the stoplights do not work. You are troubleshooting to find the problem. You are using a test lamp for this task instead of a multimeter.

109. You are performing Step 2 -- check for +24 volts DC at left stoplight. You have an assistant in the cab. What do you tell the assistant to do when you check for voltage at lead 22-461?
- A. Turn the battery switch ON and set the main light switch to STOPLIGHT.
 - B. Make sure the turn signals are off.
 - C. Step on the brake pedal.
 - D. All of the above
110. You have completed Step 2 -- check for +24 volts DC at left stoplight. The test lamp did not light. Next, you should
- A. replace the left stoplight lamp.
 - B. test the left stoplight lamp.
 - C. check for voltage at the right stoplight.
 - D. clean left stoplight lamp socket.

111. You have completed Step 11 -- check for +24 volts DC at right stoplight. No voltage was present at lead 22-460. What do you do next?
- A. Check the rear wiring harness.
 - B. Replace the right stoplight lamp.
 - C. Check for operating voltage to the stoplight switch.
 - D. Check the main light switch.
112. When you perform the voltage check on the right rear stoplight, where do you find the best electrical ground?
- A. The stoplight casing
 - B. The frame of the truck
 - C. The tailgate bumper
 - D. The stoplight lens screws
113. You have performed Step 18 -- check that light switch is supplying operating voltage to stoplight switch. Next, you go on to Step 25 if
- A. you check the rear wiring harness and it is a GO.
 - B. you check the front wiring harness and it is a GO.
 - C. you find that voltage is present in one of the leads numbered 75.
 - D. you find that voltage is present in both of the leads numbered 75.
114. You are performing Step 25 -- check stoplight switch. When you connect the test lamp to the stoplight switch, you tell your assistant to
- A. turn the main light switch OFF and make sure that the turn signals are off.
 - B. turn the battery switch ON and step on the brake pedal.
 - C. turn the battery switch OFF and make sure that the turn signals are off.
 - D. turn the main light switch OFF and step on the brake pedal.

115. You have performed Step 25 -- check stoplight switch. The test lamp did not light. What do you do next?

- A. Replace the stoplight switch.
- B. Check lead 22 wire for shorts and continuity.
- C. Put lead 75 back on the switch.
- D. Check the light switch plug for voltage.

116. Which of the following could you use to perform the voltage checks in this troubleshooting task instead of a test lamp?

- A. STE/ICE
- B. Jumper wire
- C. Digital multimeter
- D. Either A or C

117. You have been told to adjust the power steering assist cylinder on an M813. Where do you go to find this cylinder on the truck?

- A. 1
- B. 2
- C. 3
- D. 4

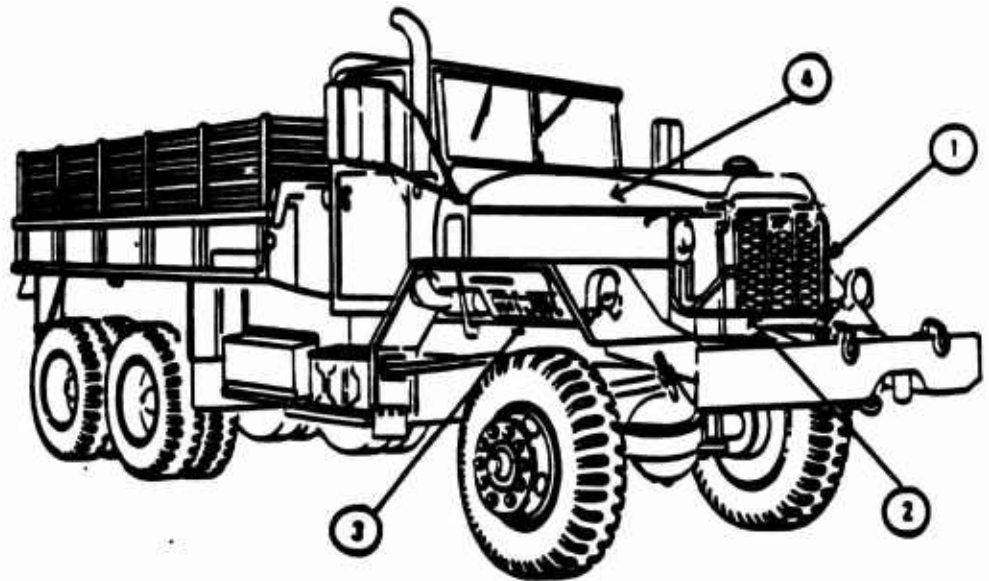

118. You are adjusting the power steering assist cylinder on an M813. The front axle is supported on jack stands and the wheels are pointed straight ahead. You must count the number of turns that the steering wheel makes from stop to stop. What do you do before counting the number of turns?
- A. Measure the travel of the cylinder.
 - B. Start the engine.
 - C. Adjust the travel of the cylinder.
 - D. Lubricate the cylinder.
119. You are adjusting the power steering assist cylinder on an M813. The front axle is supported on jack stands and the wheels are pointed straight ahead. You must count the number of turns that the steering wheel makes from stop to stop. What do you do?
- A. Turn the steering wheel all the way to the right stop and count the number of turns.
 - B. Turn the steering wheel all the way to the left stop and count the number of turns.
 - C. Turn the steering wheel to all the way to the stop in one direction, then turn it all the way to the stop in the other direction, and count the number of turns.
 - D. Turn the steering wheel all the way to the right stop and count the number of turns, then turn it all the way to the left stop and count the number of turns.
120. You are adjusting the power steering assist cylinder on an M813. You have determined that the steering wheel makes 5 turns from stop to stop. How do you position the steering wheel before adjusting the cylinder?
- A. Turn the steering wheel and look to see that the wheels are pointed straight ahead.
 - B. Turn the steering wheel all the way to the right stop and then center it.
 - C. Turn the steering wheel all the way to the left stop and then center it.
 - D. Turn the steering wheel 2 and 1/2 turns from either stop.

The following 3 questions refer to the figure below.

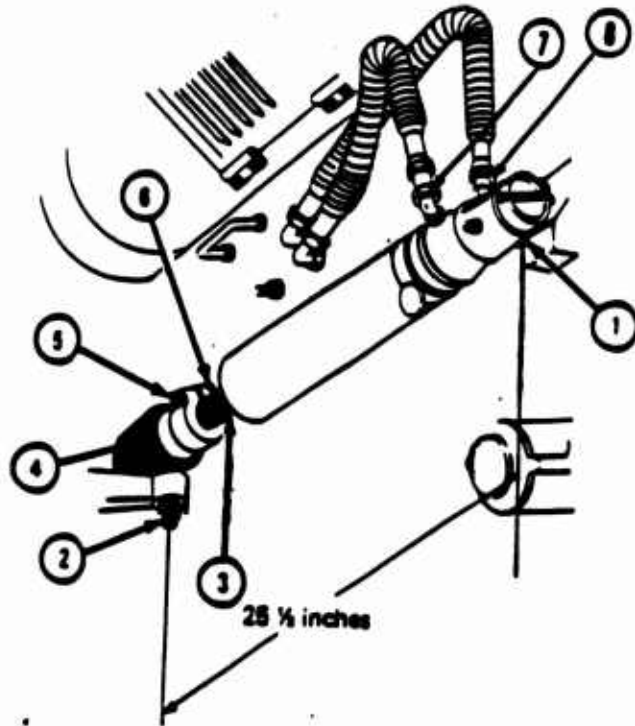

121. You are adjusting the power steering assist cylinder on an M813. You have correctly positioned the steering wheel. What do you do next?
- A. Loosen 5.
 - B. Measure the distance from 1 to 2.
 - C. Screw 3 into 4.
 - D. Tighten 6.

122. You are adjusting the power steering assist cylinder on an M813. You have measured the distance between 1 and 2. The distance is 27 inches. The correct measurement is 25 1/2 inches. What do you do?
- A. Screw 3 into 4.
 - B. Screw 3 out of 4.
 - C. Tighten 1.
 - D. Loosen 6.
123. You have adjusted the power steering assist cylinder on an M813 to the correct distance of 25 1/2 inches. Using a wrench, you tighten
- A. 1 and 6.
 - B. 2 and 5.
 - C. 5 and 6.
 - D. 2 and 3.
124. You have been told to bleed the brakes on an M813 using the pressure method (bleeder tank). Where should you be to connect the bleeder tank?
- A. Behind the right front tire.
 - B. On a creeper under front of the vehicle.
 - C. In the cab on the driver's side.
 - D. Under the hood.

125. You have been told to bleed the brakes on an M813 using the pressure method (bleeder tank). When you remove the master cylinder filler cap, you notice that the fluid level is 1 inch below the top. What should you do?
- A. Connect the bleeder tank to the master cylinder.
 - B. Add brake fluid to the master cylinder.
 - C. Drain brake fluid from the master cylinder.
 - D. Check for leaks in the brake system.

The following 2 questions refer to the figure below.

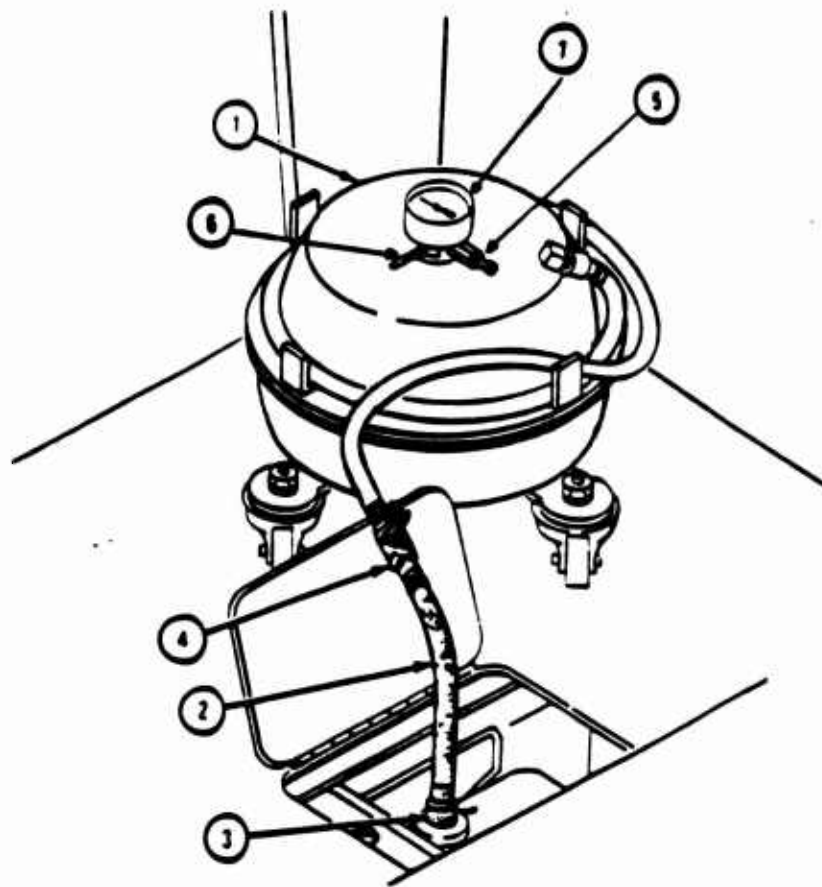

126. You are bleeding the brakes on an M813 using the pressure method (bleeder tank). Where do you connect an air hose to pressurize the bleeder tank?
- A. 4
 - B. 5
 - C. 3
 - D. None of the above
127. You are bleeding the brakes on an M813 using the pressure method (bleeder tank). You have just connected the bleeder tank to the master cylinder as shown in the figure. What do you do next?
- A. Check 7 for correct pressure.
 - B. Open 4 to pressurize system.
 - C. Loosen the bleeder valve on the wheel cylinder.
 - D. None of the above
128. You are bleeding the brakes on an M813 using the pressure method (bleeder tank). You have connected the bleeder tank to the master cylinder and you have connected a bleeder hose to the wheel cylinder. You have opened the wheel cylinder valve and observed the fluid in the container. You close the valve
- A. after 5 seconds or when the container is full.
 - B. after there are no air bubbles and the fluid is clear.
 - C. after 10 seconds and the fluid is clean.
 - D. after there have been no air bubbles for 5 seconds.

129. You are bleeding the brakes on an M813 using the pressure method (bleeder tank). You have bled the wheel cylinder. What should you use to tighten the bleeder valve?

A.

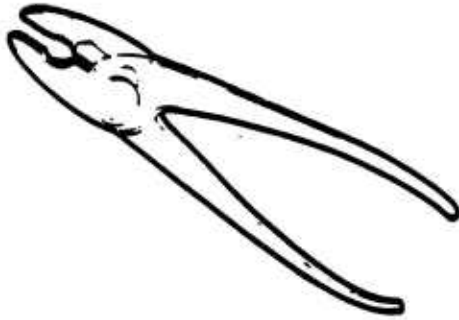

B.

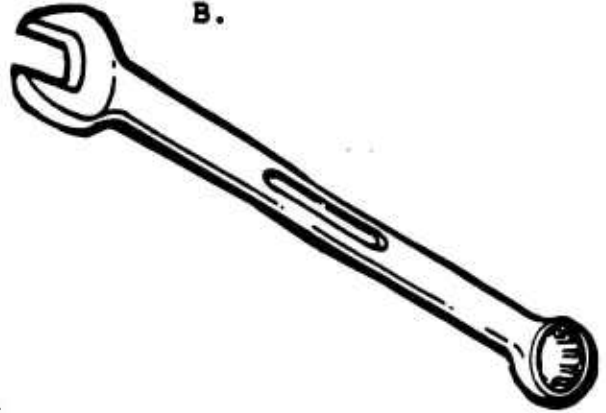

C.

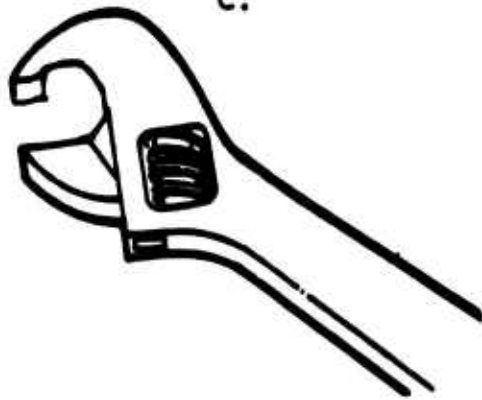

D.

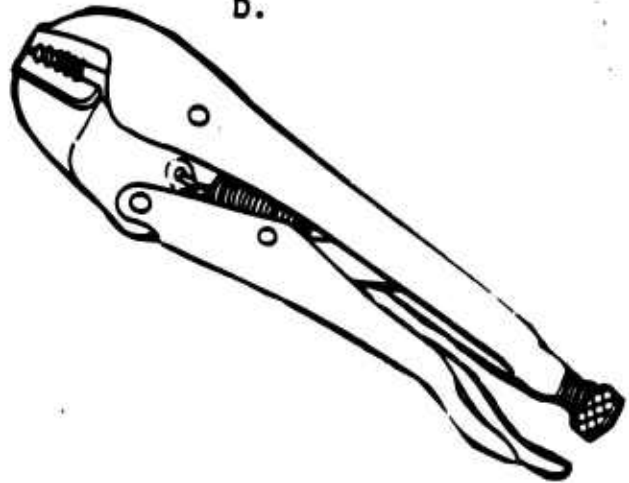

TOOL USE, GENERAL TROUBLESHOOTING, SAFETY

130. Which equipment pictured below comes in the STE/ICE kit?

- A. 1
- B. 2
- C. 3
- D. None of the above

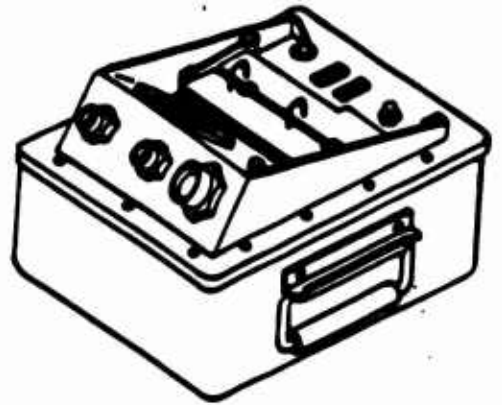

①

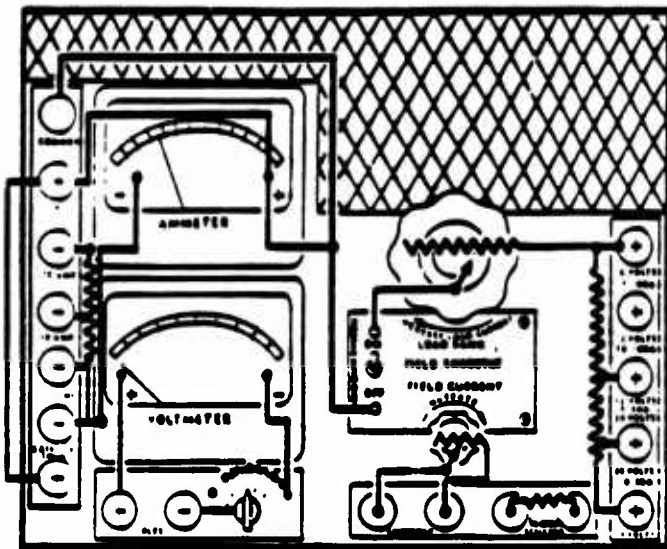

②

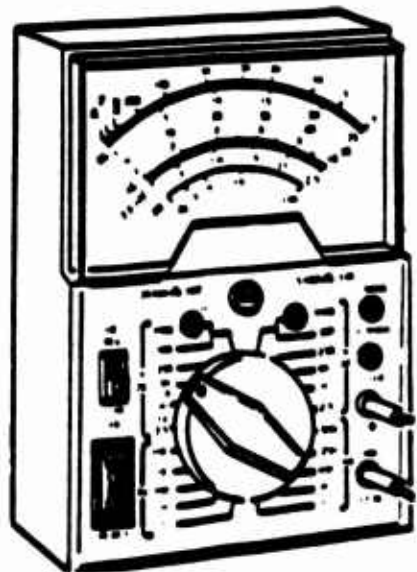

③

131. Which of the vises is found in a motor pool mounted on a work bench?

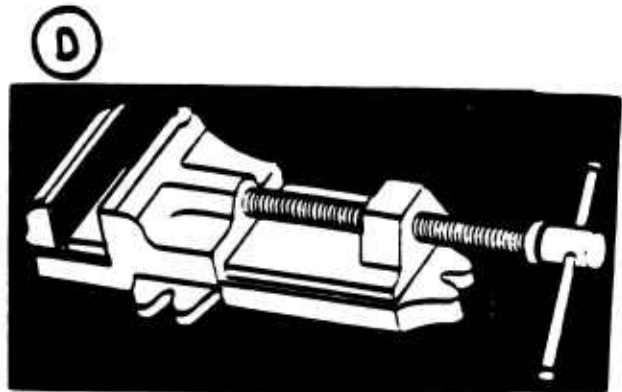
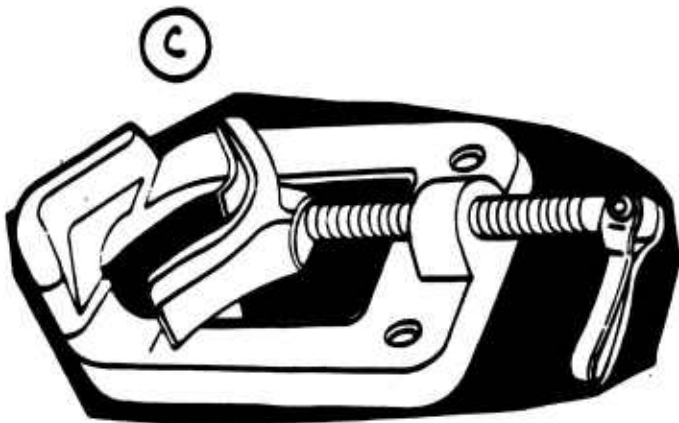
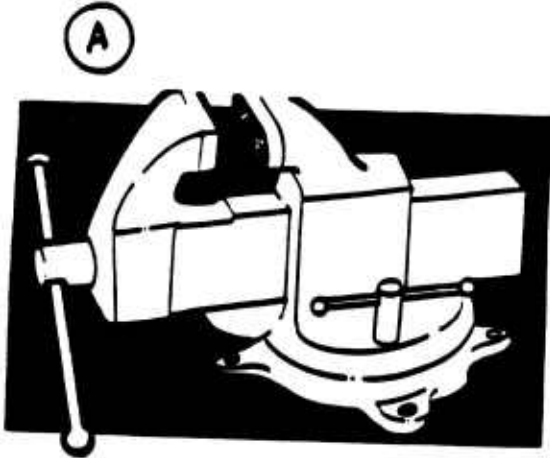

132. Which tool below would you use to remove a Phillips head screw?

- A. 1
- B. 2
- C. 3
- D. None of the tools pictured

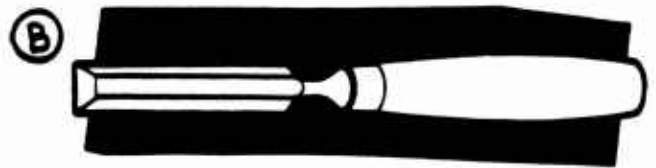

133. The tool in the picture is being used to remove

- A. a recessed screw head.
- B. a cotter pin head.
- C. a wooden dowel head.
- D. a steel rivet head.

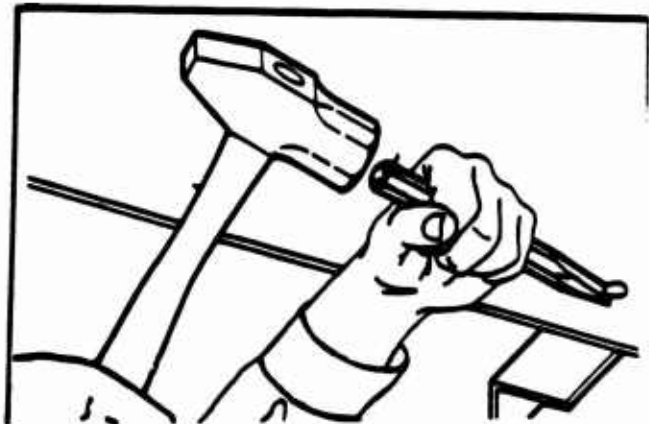

134. To torque a bolt, you should use tool ____.

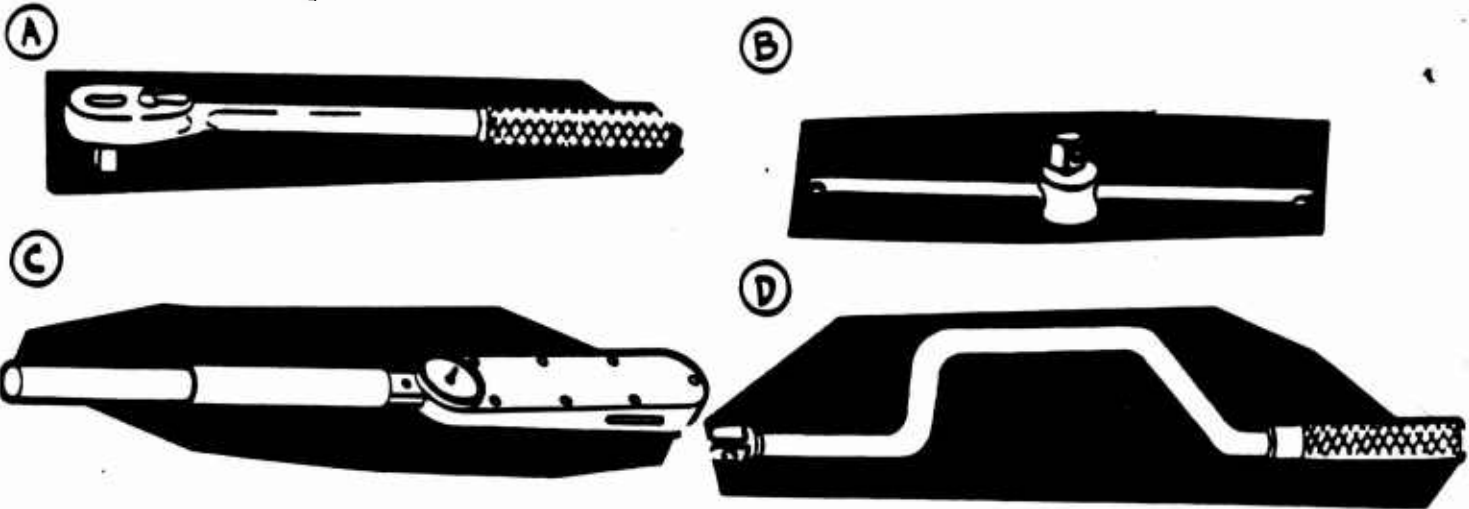

135. To check the specific gravity of a battery you should use

- A. a multimeter.
- B. the right side of a Duo-check gage.
- C. an antifreeze hydrometer.
- D. the left side of a Duo-check gage.

For the next 3 questions assume that you are working on an M923. The LTI states only that the engine won't start.

136. If you know that the fuel tank is not empty, you can narrow the problem down to the air system by
- (1) looking at the air restriction indicator to see if it is red.
 - (2) looking at fuel return lines to see whether fuel is present.
 - (3) checking draincock on the fuel filter to see that fuel drains freely.
 - (4) looking at air filter for obstructions.
- A. 1, 2, and 3
- B. 1 and 4
- C. 1, 2, 3, and 4
- D. 1, 2, and 4
137. You can determine that the truck has an electrical problem if
- (1) the starter relay clicks but the engine won't turn over.
 - (2) the engine makes no sound when you turn the ignition switch on.
 - (3) the engine turns very slowly.
 - (4) the batteries spark when you turn the ignition switch on.
- A. 1 and 4
- B. 2 and 3
- C. 2, 3, and 4
- D. 1, 2, 3, and 4
138. You would be most likely to think that a problem with the diesel fuel system is causing the truck not to start if
- A. you smell diesel fumes.
 - B. the glow plugs are not functioning properly.
 - C. you drain the fuel filter and find contamination.
 - D. the fuel gage shows less than 1/4 tank of fuel.

139. While you are using cleaning fluids, you should
- A. wear protective clothing and remove jewelry.
 - B. remove jewelry and avoid breathing fumes.
 - C. wear protective clothing and stay clear of open flames.
 - D. avoid breathing fumes and wear protective clothing.
140. Hydraulic jacks should be used for
- (1) raising vehicles.
 - (2) supporting vehicles under 5 tons.
 - (3) supporting vehicles under 10 tons.
 - (4) lowering vehicles.
- A. 1 and 2
 - B. 1, 2, and 3
 - C. 1, 3, and 4
 - D. 1 and 4
141. If a person shows the symptoms of exhaust gas poisoning, you should
- A. notify a medic.
 - B. move the person to a well-ventilated area.
 - C. keep the person warm and inactive.
 - D. do all of the above.

142. To safeguard against inhaling exhaust gases while a vehicle engine or heater is operating, you should
- (1) wear a respirator.
 - (2) wear a field protective mask for nuclear, biological, or chemical (NBC) protection.
 - (3) work in an area which provides adequate ventilation.
 - (4) be on the alert for any exhaust odors.
- A. 1 and 3
- B. 1 and 4
- C. 3 and 4
- D. 1, 2, 3, and 4
143. The safety precautions you should follow while performing maintenance on batteries are
- A. wear protective gloves, do not smoke, and wear protective eyewear.
 - B. wear protective eyewear and a respirator.
 - C. wear protective gloves and eyewear, and work in a well-ventilated area.
 - D. do not smoke and wash any areas exposed to battery acid with a baking soda solution.
144. To avoid injury and damage while performing maintenance that requires removing a wheel, you should
- A. apply the parking brake.
 - B. chock the opposite wheel.
 - C. avoid working on a hill.
 - D. do all of the above.

145. What precaution should you take whenever you handle a winch cable?

- A. Wear protective eyewear.
- B. Wear protective gloves.
- C. Ensure that engine is turned off.
- D. Keep hands away from cable while operating winch.