

AD-A264 732



2

ARMY RESEARCH LABORATORY



Sensitivity Testing of RDX/Aluminum  
Powdered Explosive Mixtures  
for the Improved Dispersed  
Explosives (IDX) Project

DTIC  
ELECTE  
MAY 20 1993  
S A D

L. Vande Kieft  
D. Bowman  
R. Maulbetsch  
M. Rodecker  
W. Hillstrom  
V. Boyle  
E. Schlegel

U.S. ARMY RESEARCH LABORATORY

A. Santiago  
D. Heltebran

BELVOIR RESEARCH, DEVELOPMENT, AND ENGINEERING CENTER

ARL-TR-113

April 1993

APPROVED FOR PUBLIC RELEASE; DISTRIBUTION IS UNLIMITED.

03 5 19 083

93-11236



## NOTICES

Destroy this report when it is no longer needed. DO NOT return it to the originator.

Additional copies of this report may be obtained from the National Technical Information Service, U.S. Department of Commerce, 5285 Port Royal Road, Springfield, VA 22161.

The findings of this report are not to be construed as an official Department of the Army position, unless so designated by other authorized documents.

The use of trade names or manufacturers' names in this report does not constitute indorsement of any commercial product.

# REPORT DOCUMENTATION PAGE

Form Approved  
OMB No. 0704-0188

Public reporting burden for this collection of information is estimated to average 1 hour per response, including the time for reviewing instructions, searching existing data sources, gathering and maintaining the data needed, and completing and reviewing the collection of information. Send comments regarding this burden estimate or any other aspect of this collection of information, including suggestions for reducing this burden, to Washington Headquarters Services, Directorate for Information Operations and Reports, 1215 Jefferson Davis Highway, Suite 1204, Arlington, VA 22202-4302, and to the Office of Management and Budget, Paperwork Reduction Project (0704-0188), Washington, DC 20503.

<b>1. AGENCY USE ONLY (Leave blank)</b>		<b>2. REPORT DATE</b> April 1993	<b>3. REPORT TYPE AND DATES COVERED</b> Final, October 1991-September 1992	
<b>4. TITLE AND SUBTITLE</b> Sensitivity Testing of RDX/Aluminum Powdered Explosive Mixtures for the Improved Dispersed Explosives (IDX) Project			<b>5. FUNDING NUMBERS</b> MIPR: A2642 PMS: 985 PAN: 2A64034A Task: A2608630641 CC: A641	
<b>6. AUTHOR(S)</b> L. Vande Kieft, D. Bowman, R. Maulbetsch, M. Rodecker, W. Hillstrom, V. Boyle, E. Schlegel, A. Santiago*, and D. Hettebran*				
<b>7. PERFORMING ORGANIZATION NAME(S) AND ADDRESS(ES)</b> U.S. Army Research Laboratory ATTN: AMSRL-WT-TB Aberdeen Proving Ground, MD 21005-5066			<b>8. PERFORMING ORGANIZATION REPORT NUMBER</b>	
<b>9. SPONSORING/MONITORING AGENCY NAME(S) AND ADDRESS(ES)</b> U.S. Army Research Laboratory ATTN: AMSRL-OP-CI-B (Tech Lib) Aberdeen Proving Ground, MD 21005-5066			<b>10. SPONSORING/MONITORING AGENCY REPORT NUMBER</b>  ARL-TR-113	
<b>11. SUPPLEMENTARY NOTES</b>  * These authors work for the Belvoir Research, Development and Engineering Center (which originated the task and provided the funding)				
<b>12a. DISTRIBUTION/AVAILABILITY STATEMENT</b>  Approved for public release; distribution is unlimited.			<b>12b. DISTRIBUTION CODE</b>	
<b>13. ABSTRACT (Maximum 200 words)</b>  The task reported on here was performed for the Belvoir Research, Development and Engineering Command, and is a portion of a significant effort in the area of Explosives Mine Countermeasures. The goal is to develop a weapon system capable of clearing a path 8m wide by 100m long through a minefield, while under enemy fire. A further consideration is the requirement that the weapon system be relatively invulnerable to all of the hazards of the battlefield, that it not cause injury or damage to friendly forces, and that it survive sufficiently long to perform its function. The weapon system under development employs the high explosive, cyclotrimethylene trinitramine (RDX), in two particle sizes (Classes 3 and 5), mixed dry with flaked aluminum, as the active ingredients. These materials are explosively disseminated into the atmosphere, and allowed to distribute themselves under the forces of gravity and aerodynamic drag, into a ground layer and an atmospheric concentration gradient with a maximum at the ground surface. The airborne cloud is initiated, and the reaction wave initiates the ground layer. The resulting pressure initiates the mines. This task was defined to quantify the sensitivities of the formulations employed, and to provide some direction in defining the packaging configuration of the final weapon system.				
<b>14. SUBJECT TERMS</b> explosives, countermine, sensitivity analyses, dispersed explosives, powdered explosives, minefields			<b>15. NUMBER OF PAGES</b> 35	
			<b>16. PRICE CODE</b>	
<b>17. SECURITY CLASSIFICATION OF REPORT</b> UNCLASSIFIED	<b>18. SECURITY CLASSIFICATION OF THIS PAGE</b> UNCLASSIFIED	<b>19. SECURITY CLASSIFICATION OF ABSTRACT</b> UNCLASSIFIED	<b>20. LIMITATION OF ABSTRACT</b> SAR	

INTENTIONALLY LEFT BLANK.

## TABLE OF CONTENTS

	<u>Page</u>
LIST OF FIGURES .....	v
LIST OF TABLES .....	v
ACKNOWLEDGMENTS .....	vii
1. BACKGROUND .....	1
2. PREPARATION OF EXPLOSIVE FORMULATIONS .....	2
3. STANDARD SENSITIVITY TESTS .....	4
3.1 Drop-Weight Impact .....	4
3.2 Friction Sensitivity .....	6
3.3 Electrostatic Discharge (ESD) .....	7
4. INTERMEDIATE-SCALE SENSITIVITY TESTING .....	8
4.1 Card Gap Testing .....	8
4.2 Fast Cook-Off .....	11
4.3 Wedge Testing .....	13
4.4 RARDE Burn Tube Experiment .....	20
5. DISCUSSION .....	24
6. FUTURE RESEARCH .....	24
7. REFERENCES .....	27
DISTRIBUTION LIST .....	29

Accession for	
NTIS CR&D	✓
DTIC TAB	✓
Unannounced	✓
Justification	✓
By	
Distribution/	
Availability Codes	
Dist	Availability Codes
A-1	

INTENTIONALLY LEFT BLANK.

## LIST OF FIGURES

<u>Figure</u>	<u>Page</u>
1. NOL Large-Scale Gap Test Fixture . . . . .	9
2. Card Gap Test Witness Plate After Formula #2 Test With 100-mm Gap . . . . .	10
3. NAWC Super Small-Scale Cook-Off Bomb . . . . .	12
4. Sketch of the Wedge Test Fixture Designed for Powder and Liquid Charges . . . . .	15
5. Wedge Test Fixture Showing Prism Modification for Additional Illumination . . . . .	16
6. Photographs of the Wedge Test Ready for Firing . . . . .	17
7. Pop Plot of Wedge Test Data for Formulas #1 and #2 With Data From Other Explosives . . . . .	19
8. Test Cylinder for the RARDE Burn Tube Experiment . . . . .	21
9. Test Configuration for RARDE Burn Tube Experiment . . . . .	21
10. Burn Tube Tests Results for Formula #1 . . . . .	22
11. Burn Tube Tests Results for Formula #2 . . . . .	23

## LIST OF TABLES

<u>Table</u>	<u>Page</u>
1. Drop-Weight Impact Test Data for Formula #1 . . . . .	5
2. DWIT Data Summary . . . . .	5
3. Friction Sensitivity Test Results . . . . .	6
4. Card Gap Test Results for Formulas #1 and #2 . . . . .	11
5. SSCB Cook-Off Temperatures . . . . .	13
6. Wedge Test Results for Formulas #1 and #2 . . . . .	16
7. Pop Plot Data for Formulas #1 and #2 and Other Explosives for Comparison . . . . .	19

INTENTIONALLY LEFT BLANK.

## ACKNOWLEDGMENTS

A special thanks to Messrs. James Austing and Douglas Baker, Illinois Institute of Technology Research Institute (IITRI), for their advice and guidance in handling and processing of the IDX materials, and to Mr. Oliver Blake for performing the wedge testing.

INTENTIONALLY LEFT BLANK.

## 1. BACKGROUND

This task was performed for the Countermine Systems Directorate of the Belvoir Research, Development and Engineering Center (BRDEC) Military Interdepartmental Purchase Request No. A2642. It was necessary in order to assess the sensitivity of powder explosive formulations utilized by BRDEC in its Improved Dispersed Explosives (IDX) program. The objectives are to determine the sensitivity of the explosive formulations and to establish a course of action to ensure compliance to the insensitive munition requirements of MIL-STD-2105A (Navy) and its associated Army supplement. This task is a portion of BRDEC's Explosives Mine Countermeasures program.

BRDEC is working on countermine technologies because the proliferation of complex fuzed surface and scatterable mines is a major threat to U.S. ground forces. Existing countermine systems for breaching minefields are ineffective against mines with complex fuzes. BRDEC is developing an explosive technology to neutralize this mine threat. IDX is a new technology that can neutralize all surface-emplaced mines regardless of fuzing.

The weapon system under development employs the high explosive, cyclotrimethylene trinitramine (RDX), in two particle sizes (Classes 3 and 5), mixed dry with flaked aluminum as the active ingredients. Class 3 RDX and Class 5 RDX have a median particle size of 450  $\mu\text{m}$  and 22  $\mu\text{m}$ , respectively. These materials are explosively disseminated into the atmosphere and allowed to distribute themselves under the forces of gravity and aerodynamic drag into a ground layer and an atmospheric concentration gradient with a maximum at the ground surface. This distribution occurs because of the great disparity in particle size between the two classes of RDX. After a short interval (approximately 150 ms) from the initial event, the airborne cloud is initiated to detonation. The reaction wave travels downward, gathering strength, and initiates the ground layer. The resulting pressure at the air-ground interface is on the order of 65,000 psi. This is sufficient to initiate many types of mines and to disrupt, to the point of deactivation, other surface-emplaced mines. Also, simple pressure fuzes are activated on some buried mines.

In September 1991, BRDEC successfully tested prototype munitions that simultaneously detonated both the ground layer and the cloud explosives. These results support the continued development of IDX into a minefield breaching system.

A perceived problem is that of the sensitivity of this prototype weapon system. The final configuration has not yet been determined, so this task was defined to quantify the sensitivities of the formulations employed, and possibly to provide some direction in defining the packaging configuration of the final weapon system.

Our methodology for this task was to mix the IDX formulations and conduct a series of tests to assess sensitivity. After completion of these tests, technical approaches were identified to ensure that the explosives under consideration are safe for transportation and weaponization.

## 2. PREPARATION OF EXPLOSIVE FORMULATIONS

Two formulations are used in this system. They are:

Formula #1: 70% Class 5 RDX / 30% Flaked Aluminum

Formula #2: 97.5% Class 3 RDX / 2.5% Flaked Aluminum

(Percentages are by weight.)

The RDX was acquired from the Illinois Institute of Technology Research Institute (IITRI) Kingsbury Ordnance Plant (KOP), La Porte, IN. This was to assure that any lack of correlation between the results from this task with previous results would not be due to material inconsistencies. IITRI had purchased the RDX from Ensign Bickford, who, in turn, had purchased it from the Royal Armament Research and Development Establishment (RARDE) in England. RARDE does not use the Bachman Process—the process used by the Holston Army Ammunition Plant. The Bachman Process yields a product with a significant fraction of cyclotetramethylene tetranitramine (HMX)—anywhere from 2% to 25%. RARDE uses the acetic anhydride process which is not supposed to yield any HMX.

Differential Scanning Calorimetry (DSC) was used to analyze the IITRI RDX. The Class 3 material showed no evidence of HMX, but the Class 5 material gave an indication of the presence of HMX. To quantify the HMX content, High Performance Liquid Chromatograph (HPLC) runs were made. IITRI Class 3 RDX yielded 1% HMX, and IITRI Class 5 RDX yielded 2 % HMX. Current, standard RDX and HMX were also tested: The RDX had 9% HMX, and the HMX had 3% RDX.

Both classes of the IITRI RDX have a strong, moldy odor. In addition, the Class 5 RDX has numerous deposits of fine, powdery, black debris on the surface of the bagged RDX. Samples of the black material were analyzed in a DSC. The contaminated material melted at the same temperature as standard RDX; however, the reaction exotherm of this material was slightly lower (4° C) than that of standard RDX. A contaminated sample was washed with a 50/50 solution of ethanol/water and dried. A DSC trace on this material was nearly identical to standard RDX. Also, samples from the interior of this same bag gave normal DSC spectra; thus, this material was used in this task, and the moldy material avoided.

The aluminum is Reynolds type 40XD flaked aluminum, produced in Louisville, KY. The flakes are coated with 2-3% stearic acid, which gives it a soapy smell.

The ingredients are thoroughly dried before blending. This is usually done in a vacuum oven at 80° C for 4 hrs in small batches (approximately 100 g). Flaked aluminum is very messy to handle, so coveralls, surgical gloves, and respirators were worn. It is advisable to work in a fume hood, with a furnace filter over the exhaust port to catch aerosolized aluminum. Clean-up can be done with liquid Palmolive soap and water.

Early batches were blended in a 1-pint container on a ball mill. On advice from IITRI, four small wooden cubes (like game dice) were included in the mix to prevent caking. A mixing time of 45 min was used, and appeared to produce a uniform blend; however, upon closer inspection, small-scale irregularities in color were observed. That these were significant was indicated by the Drop Weight Impact Test (DWIT) results. The 50% reaction height for Formula #1 prepared as above was approximately 37 in, whereas with more thorough blending it became 70.1 in. This is discussed in detail in the section on the DWIT results.

Results obtained with material processed as above were discarded because of the non-uniformity of the material. Further batches were prepared by using small, smooth stones in

with the mix instead of the wooden cubes. The density of these stones, measured in the autopycnometer, was  $2.582 \text{ g/cm}^3$ , somewhat greater than that of RDX and much greater than that of wood. Our principal concern in using the stones in place of the wooden cubes was the possibility of changing the particle size distribution. To avoid this possibility, the ball mill was run at a low speed, such that the stones would of necessity roll along near the bottom of the container and not be carried to the top and then drop onto the RDX. This procedure produced a blend that appeared much more uniform than those produced in the earlier manner, and also yielded consistent results in the subsequent testing.

### 3. STANDARD SENSITIVITY TESTS

Standard sensitivity tests include the DWIT, friction, and electrostatic discharge (ESD) tests. The purpose of these tests is to enable the researcher to ensure that the materials to be used are safe to use in the quantities required.

3.1 Drop-Weight Impact. The instrument used for the DWITs is the Bureau of Mines Type 12 Impact Tester. The apparatus and procedure for this test have been described in many places. One of the principal references for this test is the Navy publication, NAVORD OD 44811 (1972). A 2.5-kg weight is dropped from various heights onto suitably prepared samples, and observations are made for evidence of reaction (viz., sound, light, odor, smoke, or the post-test appearance of the sample). If any of these is observed, or the sample appears to have reacted, the test is noted as positive. Following a positive result, the weight is set at a smaller height; for a negative result, the weight is set at a greater height. Approximately 85 of these tests are made on each candidate material in order to allow a sufficiently accurate statistical estimate to be made. The end result of a series of these tests is the height at which a 50% probability of reaction exists—known as  $H_{50}$ . This number was derived through exercise of a statistical data reduction program called the Maximum Likelihood Estimator Program (private communication, 1992).

After running a series of DWITs, the data are grouped (Table 1) for entry into the Maximum Likelihood Estimator Program. The result of running this program on the data of Table 1 is a 70.1-in height for which a 50% probability of reaction exists.

Table 1. DWIT Data for Formula #1

Height (in)	Go's	No-Go's	Total
67	0	2	2
68	2	7	9
69	6	14	20
70	12	15	27
71	13	7	20
72	6	0	6

The complete set of reduced DWIT data is shown in Table 2.

Table 2. DWIT Data Summary

Material	H <sub>50</sub> (in)	Sigma (in)
Class 3 RDX	17.7	2.1
Class 5 RDX	20.2	4.6
Formula #1	70.1	1.9
Formula #2	19.8	3.2
Class 1 RDX	17.3	1.5

Data were taken on standard Class 1 RDX from Holston Army Ammunition Plant, to be available for normalization purposes. For this material,  $H_{50} = 17.3$  in, with  $\sigma = 1.5$ . This is very close to the DWIT sensitivities of both the Class 3 and 5 RDX supplied for these tests, so this tends to validate the results. Formula #2, which is primarily RDX, has about the same sensitivity as plain RDX.

The dominant effect here is that of the aluminum in the formulations. The aluminum may have desensitized Formula #2 slightly, but it had a strong effect on the sensitivity of Formula #1, which has 30 wt-% flaked aluminum, whereas Formula #2 has only 2.5 wt-%. The aluminum appears to strongly desensitize the product to the drop-weight stimulus.

If there is any particle size effect, it is difficult to determine from these data because the standard deviations may obscure it.

3.2 Friction Sensitivity. The instrument used for these tests is the BAM (Bundesanstalt für Materialprüfung) Tester, manufactured by Julius Peters K. G., Berlin, Germany. The procedure used is detailed in Wang and Hall (1985) and NAVORD OD 44811 (1972).

A powder sample of the material under test is placed on a ceramic plate made specifically for this instrument and test procedure. A ceramic pin, mounted on a pivoted lever arm, is allowed to press the material against this plate with a force dependent upon the weight hung on the lever arm and its position relative to the pivot. When the operator energizes the instrument, the ceramic plate moves in one complete cycle (viz., right-left-right) under the stationary pin, thus shearing the energetic material between the pin and plate. Tests are labelled as Go's if any of the following is observed: decomposition (discoloration or odor), flame, crepitation (crackling noise), or explosion.

Data were taken on the two particle sizes of RDX and on the formulas of interest in this study. The friction sensitivities of standard TNT and Comp B were also measured for calibration purposes. Results are in Table 3. Class 5 RDX is an ingredient in Formula #1, and Class 3 RDX is an ingredient in Formula #2. Particle size has an effect, the smaller particle size material having the lower friction sensitivity. The friction process would tend to break the explosive grains through the weak points (e.g., voids and dislocations). The smaller grains would tend to have fewer of those per unit volume, especially if they were produced through fluid energy milling.

Table 3. Friction Sensitivity Test Results

Material	Sensitivity (kg)
IITRI Class 3 RDX	10.8
IITRI Class 5 RDX	12.0
Formula #1	12.0
Formula #2	10.8
TNT	>36
Comp B	>36

However, the significant information from these tests is that the aluminum has no effect whatever on the friction sensitivity. The friction sensitivity of both Classes 3 and 5 RDX did not change with the addition of the flaked aluminum.

3.3 Electrostatic Discharge (ESD). These tests were done in accordance with Appendix A of NAVORD OD 44811 (1972), using a locally fabricated instrument. As before, all materials under test were thoroughly dried before testing. All tests were run with a potential of 5 kV, and the energies applied were varied by using different capacitance values ranging from 0.0001  $\mu\text{F}$  to 0.5  $\mu\text{F}$ . A positive test is one that produces decomposition as evidenced by smoke, flame, flash, odor, or noise. Tests are run until 20 consecutive failures to react are observed at the highest possible energy level.

Classes 3 and 5 RDX were tested successfully (i.e., 20 consecutive failures) at the highest energy level specified by the testing protocol, 6.25 J. In cases of this nature, the protocol requires further testing at lower energy levels because at the highest energy level the expanding air from passage of the spark discharge could have blown the reactants out of the discharge path. Tests at 0.625 J and 0.012 J also yielded negative results.

The aluminized formulations were tested, with the following results:

Formula #1: 20 consecutive failures at 0.25 J (5 kV/0.02  $\mu\text{F}$ )

Formula #2: 20 consecutive failures at 0.625 J (5 kV/0.05  $\mu\text{F}$ ).

These sensitivities are not excessive from the standpoint of working with the materials. The human body can retain at most 80 mJ of electrostatic energy (although possibly at considerably higher voltages than the 5 kV used in these tests). A total of 250 mJ is insufficient to initiate Formula #1 material, and Formula #2 is still less sensitive.

However, the aluminum does significantly sensitize the RDX formulations. One possible mechanism is that the aluminum particles could form conductive chains through the RDX. By the nature of the formulations, these chains would have small gaps, and these gaps would intensify the energy deposition per unit volume. There exists a certain similarity to some detonator designs which have two conductors separated by a short, high-resistance wire

which is embedded in energetic material. In this case, the high resistance wire is replaced by very small gaps between the conductive particles, these gaps being filled with RDX.

In many electrostatic discharge tests, one must carefully observe the results, looking for one of the five indicators previously mentioned as indicating a GO. In these tests, with the aluminum in the formulations, these were never a "partial GO"—a GO was always violent, never a doubtful event.

#### 4. INTERMEDIATE-SCALE SENSITIVITY TESTING

4.1 Card Gap Testing. The card gap test procedure of the Naval Ordnance Laboratory (NOL) as defined and described in Army publications TB 700-2 and AMC 706-180. Local procedure differed in two respects. The test fixture was inverted from the one indicated in the reference (i.e., the witness plate was on top of the test configuration, and the detonator was on the bottom). The reason for this was that the test materials were in the form of powders, and it was much more convenient to maintain the 1/16-in air gap between the witness plate and the material under test with the configuration inverted. Figure 1 shows the normal configuration, and Figure 2 shows the results of a test in which the acceptor charge detonated. Note the clean hole in the witness plate. The other variation from NOL's (Figure 1) was the use of solid cylinders of polymethylmethacrylate (PMMA) instead of cellulose acetate cards. No problems are anticipated from these modifications.

Fourteen shots were fired for the two formulations. The results are shown in Table 4. Shots 10 and 11 resulted in a slight dent in the center of the witness plate. A shot is not recorded as a GO unless the witness plate is perforated or broken into pieces.

It can be seen from these data that Formula #1 has a sensitivity of between 50 and 55 mm of PMMA. This is on the order of 200 cards, near the sensitivity of Composition B. The sensitivity of Formula #2 is between 100 and 110 mm, considerably more sensitive than Formula #1, approximately 400 cards—a very high value! To place this in perspective, it should be noted that the handbook value for pure, dry RDX (likely Class 1) is approximately 300 cards. No effort was made to separate the effects of particle size and the presence of aluminum.

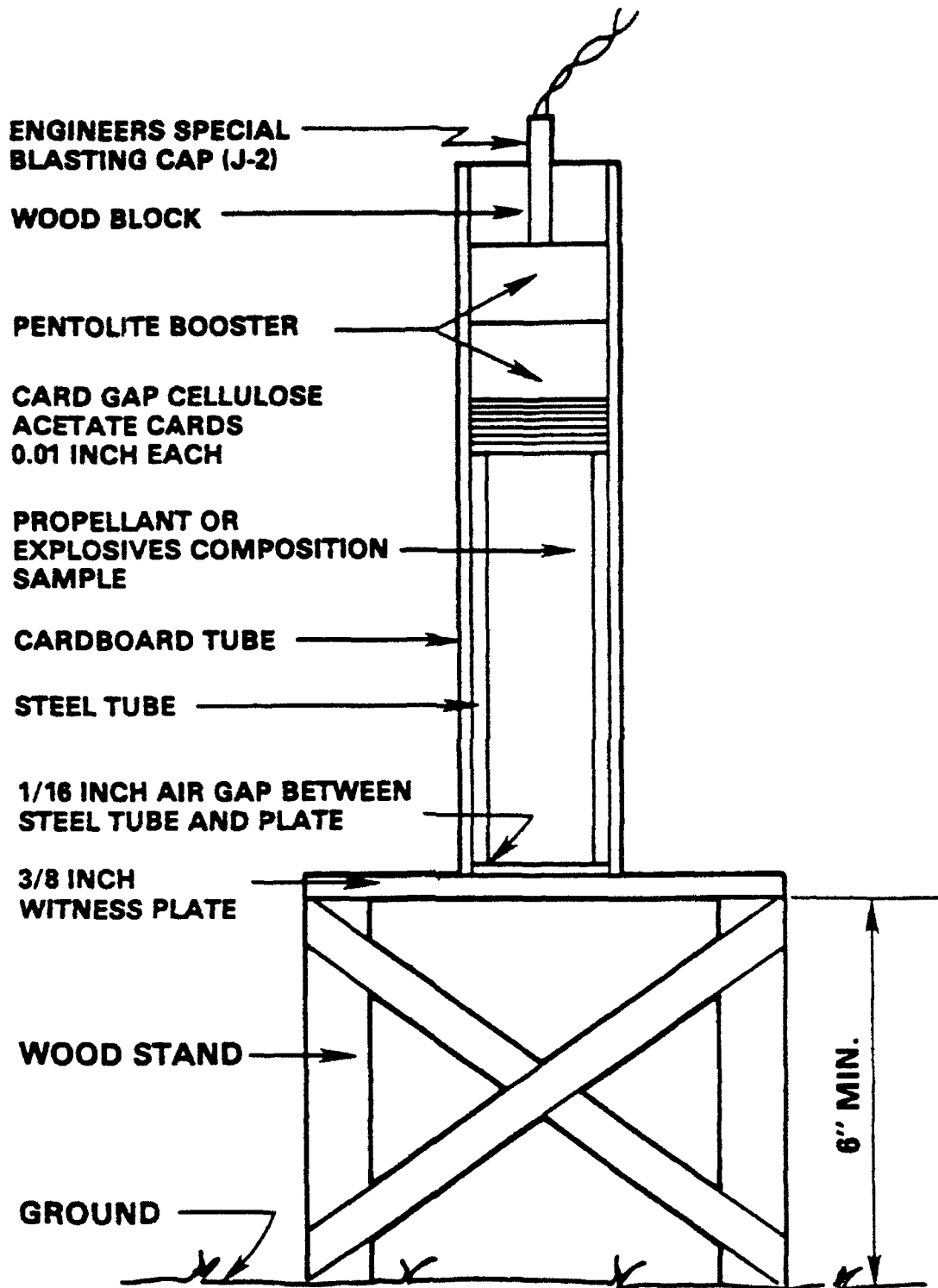

Figure 1. NOL Large-Scale Gap Test Fixture.

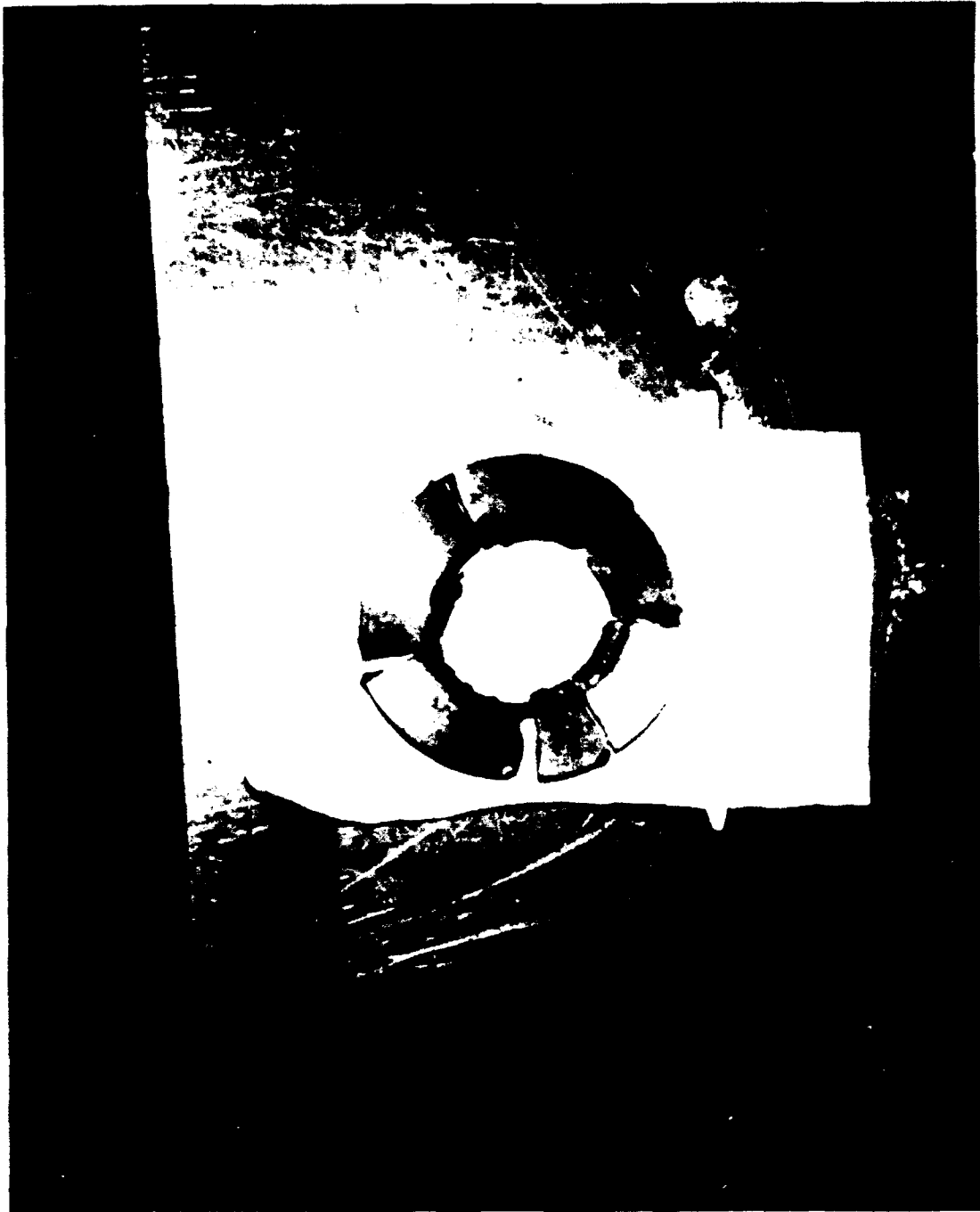

Figure 2. Card Gap Test Witness Plate After Formula #2 Test With 100-mm Gap.

Table 4. Card Gap Test Results for Formulas #1 and #2

Shot No.	Formula No.	Gap (mm)	Result
1	2	20	GO
2	1	20	GO
3	2	40	GO
4	2	60	GO
5	1	60	NO-GO
6	1	60	NO-GO
7	1	50	GO
8	1	50	GO
9	2	80	GO
10	1	55	NO-GO
11	1	55	NO-GO
12	2	90	GO
13	2	100	GO
14	2	110	NO-GO

4.2 Fast Cook-Off. The test devices used for the fast cook-off part of the task were the Super Small-Scale Cook-Off Bombs (SSCB), developed by Jack Pakulak, Naval Air Weapons Center (NAWC), China Lake, CA. These devices are detailed in Figure 3. One significant advantage of this device over older designs is the small amount of explosive used in the performance of each test, only 20 g at usual densities. However, the results achieved by the use of these devices closely track those from earlier designs, those requiring much larger quantities of explosive. These devices were carefully calibrated (Pakulak and Cragin 1983) at the NAWC.

Electrical power is supplied to the heater elements, and temperature is recorded as a function of time. Single-phase 218VAC electrical power is used. The temperature rise rate is on the order of 1° C/s, and since explosion usually occurs near 240° C, the time to explosion is approximately 4 min.

Two series were run on the Formula #1 material. Tests 1–3 and 7–8 were run on the first blend (viz., that mixed by use of the wooden cubes to prevent caking); tests 9–12 were run on a later blend, that mixed by use of small stones. Tests 4–6 were run on Formula #2 material. Results are shown in Table 5.

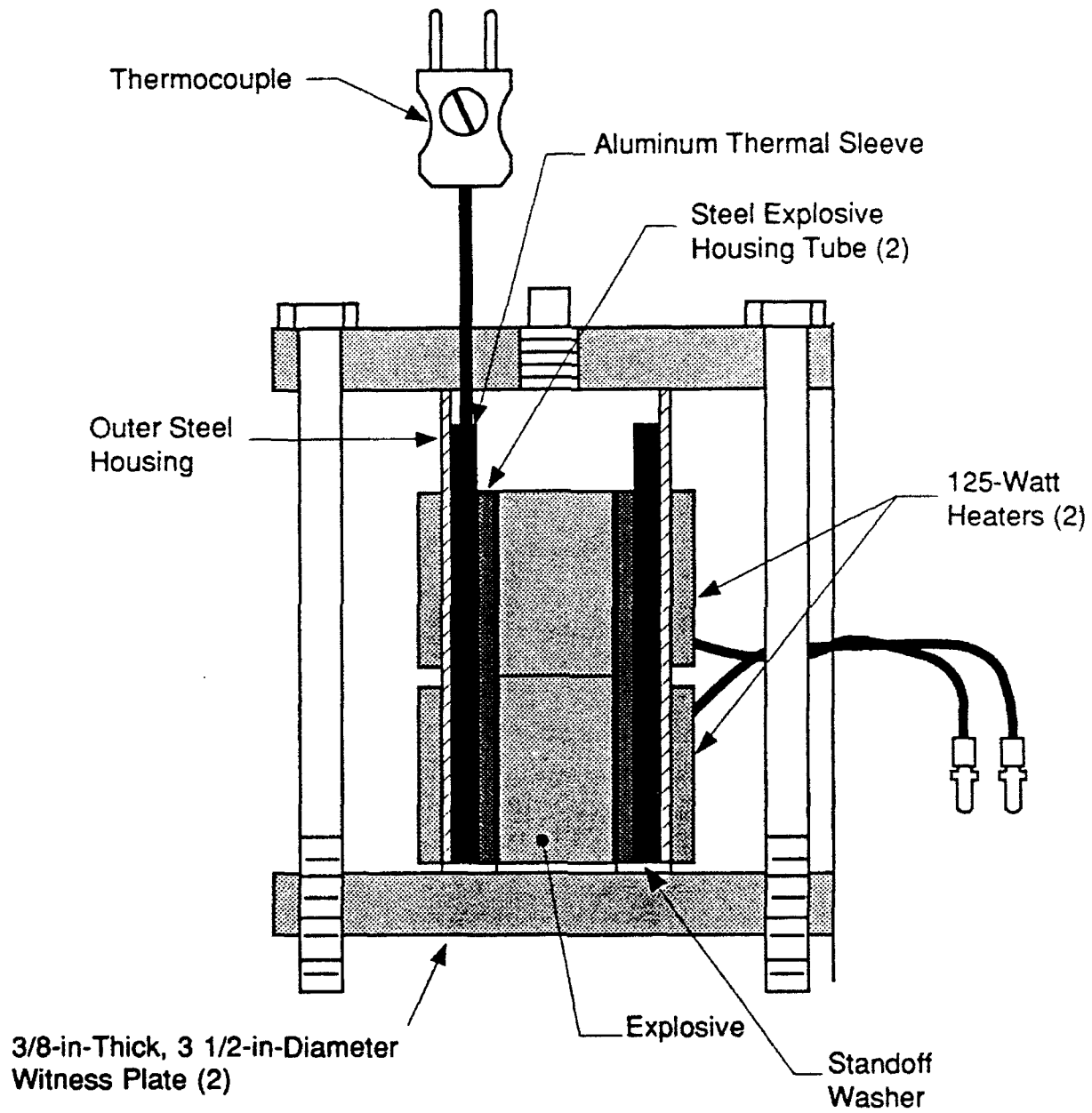

Figure 3. NAWC Super Small-Scale Cook-Off Bomb.

Table 5. SSCB Cook-Off Temperatures

Test No.	Formula #1 (°C)	Formula #2 (°C)	Comments
1	—	—	Instrumentation Failure
2	—	—	Instrumentation Failure
3	259	—	—
4	—	234	—
5	—	230	—
6	—	241	—
7	223	—	—
8	—	—	Same time as for #7— Thermocouple Failure
9	241	—	—
10	240	—	—
11	253	—	—
12	239	—	—

The combination of instrumentation problems and non-uniform mixing yielded poor results for the early tests on Formula #1. Tests 9–12 gave good results. To err on the side of safety, it is suggested that the test #11 result be discarded and the other data averaged. If this is done, the cook-off temperature for Formula #1 becomes 240° C.

Test results for Formula #2 were much more consistent, yielding an average cook-off temperature of 235° C. Any munition containing both of these formulations would have to be considered to have the lower of these cook-off temperatures (viz., 235° C).

4.3 Wedge Testing. In the usual form of wedge testing, one end of a cylinder of the explosive under test is machined to a flat surface which makes a 75° angle with its axis. (This angle is chosen so that the detonation wave travelling parallel to the axis of the cylinder does not experience interference with release waves from this inclined surface.) This forms the upper surface of the test configuration on which the progress of the detonation wave front is observed with a streak camera. The lower surface of the test charge, orthogonal to its axis, is placed on a buffer to attenuate the incident shock wave. This, in turn, rests on an explosive sheet, which sets on a plane wave lens. The detonation wave is initiated at the base or apex of the plane wave lens, propagates through the lens, and initiates the explosive sheet almost simultaneously over its entire surface. This explosive sheet further smoothes the detonation

wave surface before impinging onto the buffer. The buffer attenuates the wave to the shock pressure value desired at the base of the explosive under test. For more information on this test, see Lindstrom (1964).

This test configuration was modified for the same reason as was the card gap configuration (i.e., the test explosives in this evaluation were low-density powders, and powders cannot be machined into wedges). To overcome this problem, a new configuration was devised (shown in top and side views in Figure 4). The upper half of the fixture is a covering, used only for applying vacuum to the charge during the loading process. Vacuum was not required for loading these charges. In early tests of this device, it was found that the wedge was not sufficiently illuminated. To correct this, a prism of PMMA, the material from which this device was fabricated, was attached onto the side of the wedge test cylinder (Figure 5). The angles were cut so that light normal to the prism surface would pass undiffracted to the lower surface of the wedge, and from there be reflected vertically toward the streak camera. Photos of this system, ready for firing, are shown in Figure 6, both from the side and in perspective.

To load this device, its volume up to the top of the wedge is measured, and the explosive is weighed out to yield the desired density when filled to this point. The explosive is poured into the fixture and vibrated until it is all in and the device is filled to the correct level. The test device is then placed on the attenuator pad and fired as described above.

These wedge tests were done in order to measure the run distance to detonation as a function of incident shock pressure so that the shock sensitivity of these explosives could be characterized. A 4-in plane wave lens was used with various buffer systems which had been calibrated beforehand in order to obtain a range of initial shock pressures in the wedge. Table 6 shows the wedge test results. Formula #1 was 70% Class 5 RDX/30% flaked aluminum, vibrated to a bulk density of  $0.701 \text{ g/cm}^3$ . Formula #2 was 97.5% Class 3 RDX/2.5% flaked aluminum, vibrated to a bulk density of  $1.201 \text{ g/cm}^3$ . The initial shock velocity and the run distance to detonation were difficult to measure accurately for shots 06-01-92 and 06-02-92 because of their short run-up to detonation.

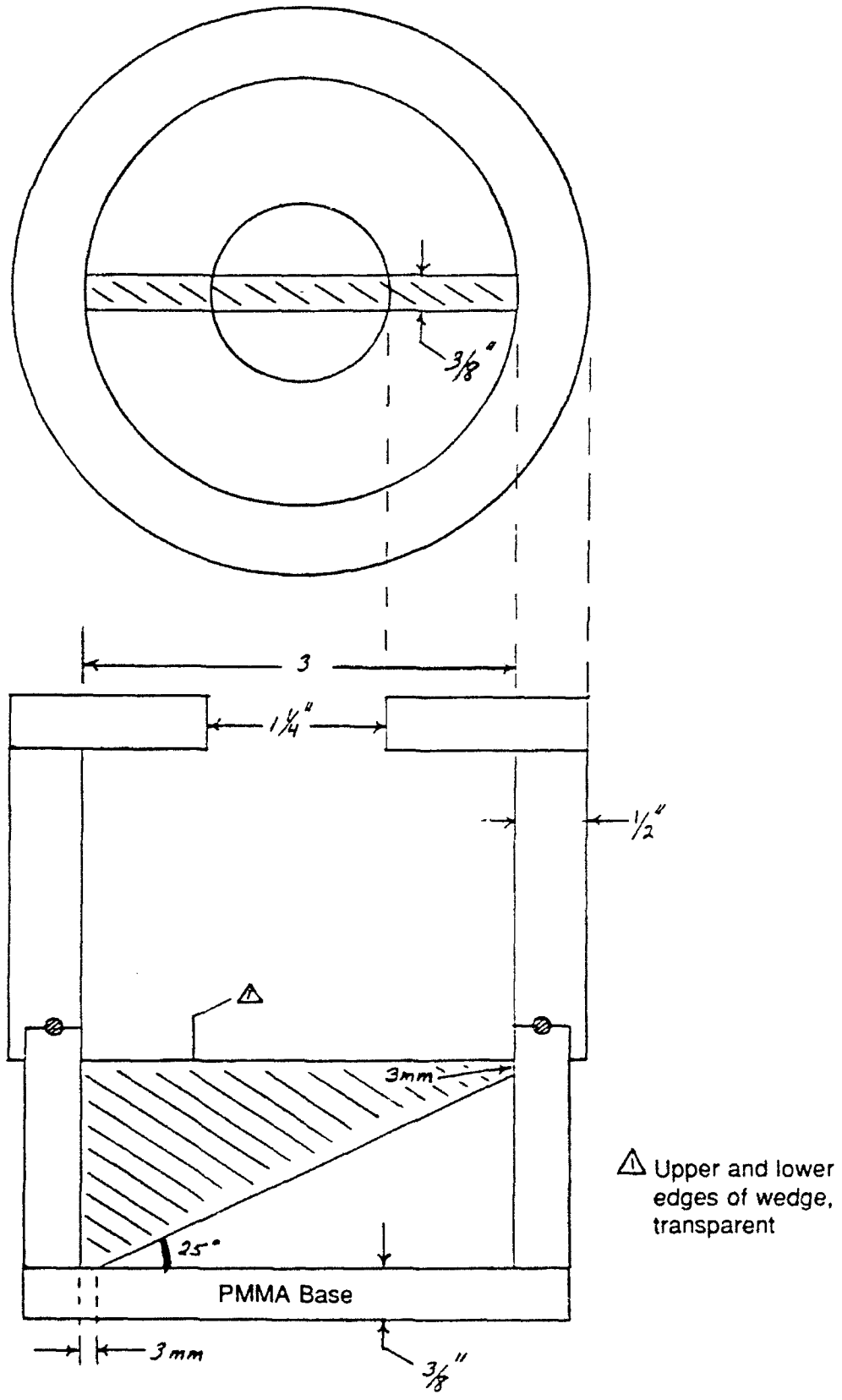

Figure 4. Sketch of the Wedge Test Fixture Designed for Powder and Liquid Charges.

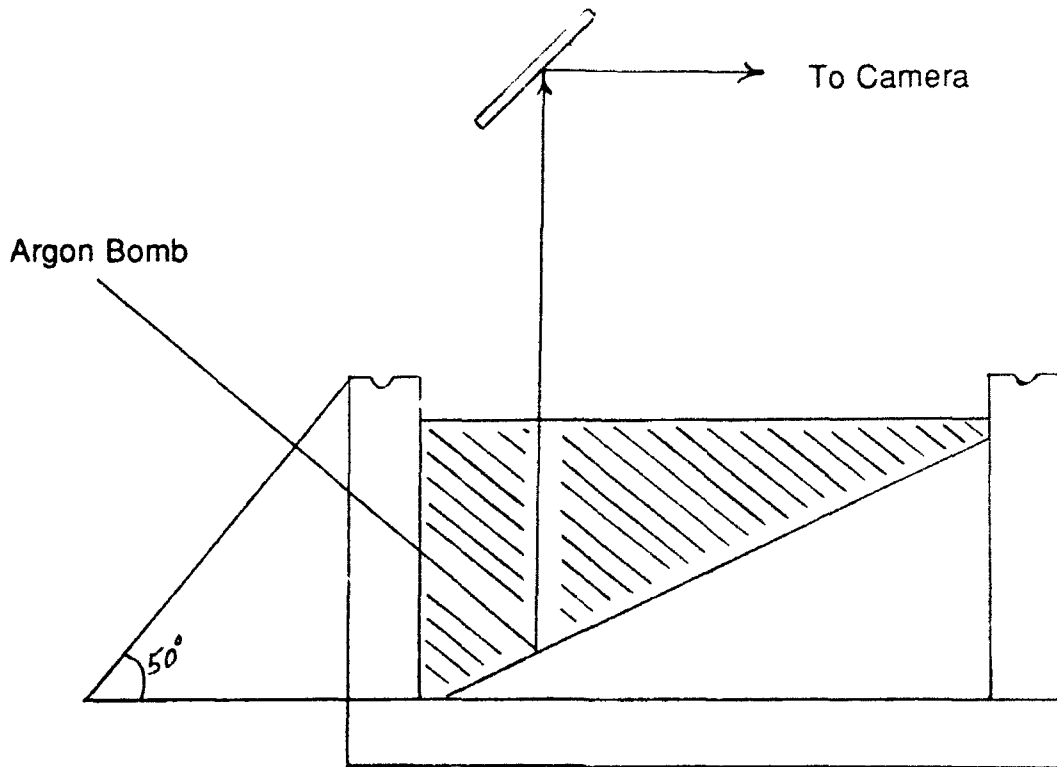

Figure 5. Wedge Test Fixture Showing Prism Modification for Additional Illumination.

Table 6. Wedge Test Results for Formulas #1 and #2

Date	Formula	Shock Velocity (mm/ $\mu$ s)	Shock Pressure (kbar)	Dist. to Deton. (mm)	Det. Rate (mm/ $\mu$ s)	Est. Det. Pressure (kbar)
07-13-92	#1	2.772	20.5	2.1	3.687	28.6
06-02-92	#1	3.016	28.6	0.5	3.792	30.2
06-23-92	#1	4.457	(This appears to have been an overdriven detonation)			
06-18-92	#2	3.786	35.5	2.8	6.483	151.3
06-01-92	#2	4.544	52.8	1.9	6.221	139.2



a. Perspective View

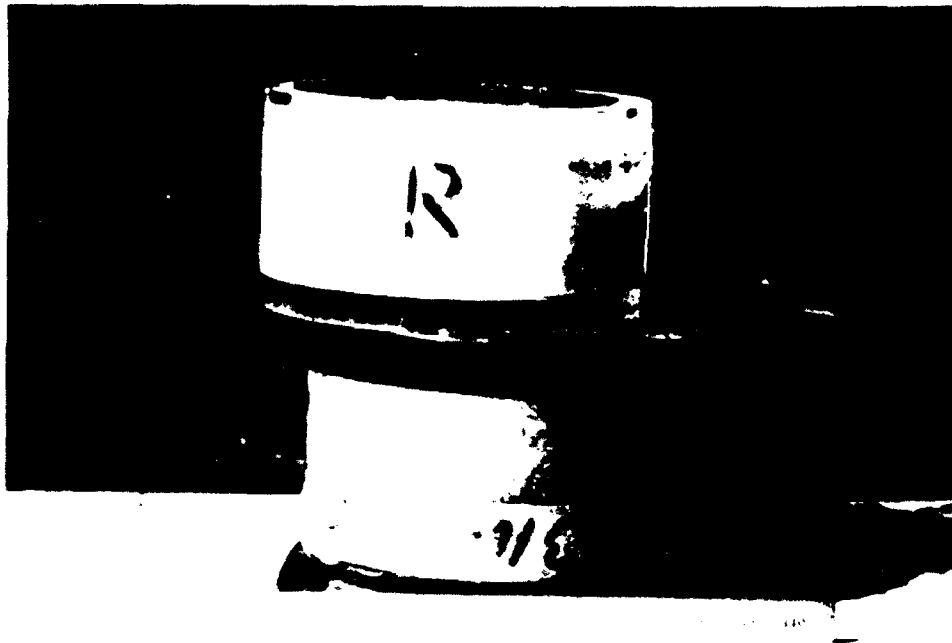

b. Side View

Figure 6. Modified Wedge Test Experiment.

The detonation pressure was estimated as follows:

$$P = (\text{density})(\text{det. rate})(\text{part. vel.}).$$

The particle velocity was assumed to be about 30% of the detonation rate.

$$P = (\text{density})(D)(0.3D)(10) \text{ kbar},$$

using density units of  $\text{g/cm}^3$  and velocity units of  $\text{mm}/\mu\text{s}$ , where

$$D = \text{the measured detonation rate.}$$

The Wedge Test data were graphed as a pop plot along with data from other explosives for comparison purposes (Figure 7). The curves in this figure are identified, along with associated information, in Table 7.

As incident shock pressure increases, free run to detonation decreases, as would be expected. The most sensitive region of this plot is the lower left corner where low shock pressures would result in short run distances to detonation. Formula #1, plotted as curve 10 in Figure 7, appears to be highly sensitive to moderate shock pressures; however, the slope of curve 10 is very steep, indicating that the sensitivity decreases rapidly with decreasing shock pressure. Formula #2, curve 11, is much less shock sensitive than Formula #1 on the high pressure end of the scale, but it appears to have a crossover point around 1.5 GPa, to the lower shock pressure side of which it would be more sensitive to shock.

The Card Gap Test showed Formula #2 to be extremely sensitive to shock initiation, considerably more so than Formula #1. This implies that curve 11 would be valid if extrapolated to the region well to the left of the crossover point of curves 10 and 11. This region has not yet been explored in wedge testing of these formulations. If the extrapolation is valid, Formula #2 would require very little shock pressure to initiate but would then require a long distance to run up to full detonation. In small quantities of material, it would not reach detonation; however, in the quantities under consideration, it could easily reach full detonation. This was corroborated by the Gap Test results of this study.

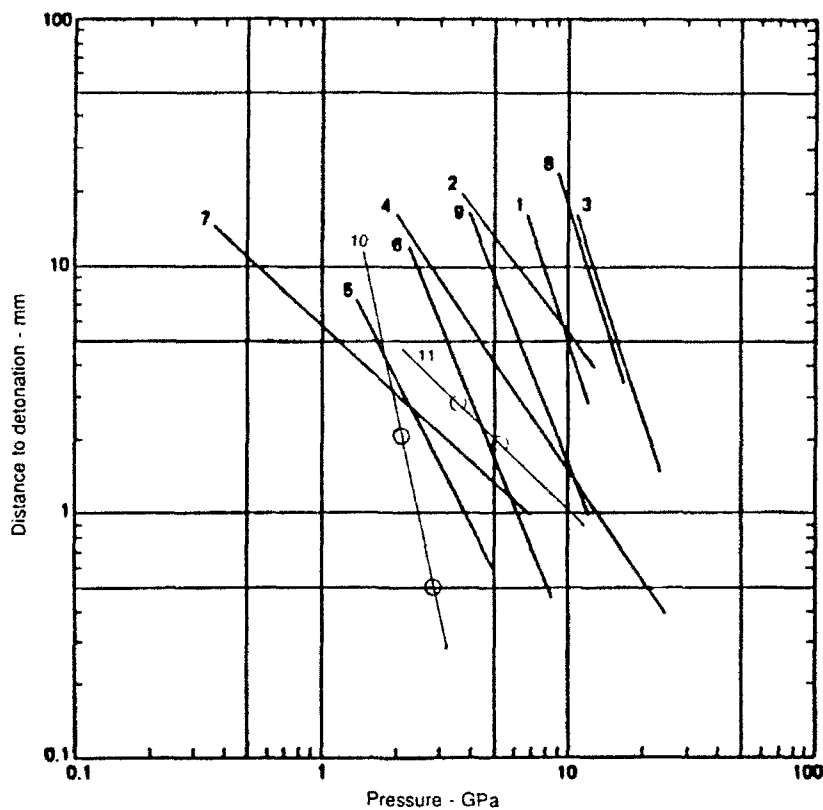

Figure 7. Pop Plot of Wedge Test Data for Formulas #1 and #2 With Data From Other Explosives.

Table 7. Pop Plot Data for Formulas #1 and #2 and Other Explosives for Comparison

Curve No.	Explosive	Density (g/cm <sup>3</sup> )	Reference
1	Baratol (cast)	2.6-2.62	1
2	Composition B	1.72	2
3	LX-17	1.90	3
4	PBX-9404	1.84	1
5	PBX-9407	1.6	1
6	Tetryl	1.70	1
7	Tetryl	1.30	1
8	TNT (cast)	1.62-1.63 <sup>a</sup>	1
9	TNT (pressed)	1.63	2
10	IDX Formula #1	0.701	Current Work
11	IDX Formula #2	1.201	Current Work

<sup>a</sup>25° C - 73° C

NOTES: 1 - Gibbs and Popolato 1980; 2 - Ramsey and Popolato 1965; 3 - Dobratz et al. 1979.

4.4 RARDE Burn Tube Experiment. This experiment originated at RARDE in England, the putative source of the RDX used in this task. The intent of this experiment is to demonstrate whether the formulations being investigated will transition to explosion or detonation in response to a soft ignition, viz., an electric match. This was considered to be vital information since significant quantities of these materials will be packaged together into some final configuration, having some degree of confinement.

The hardware for this experiment is depicted in Figure 8, and is described in Dyer et al. (1981). A photograph of the test configuration is shown in Figure 9. The threads at the ends of the tube are not tapered. The caps have flat bottoms, and pipe ends are flat, smooth and perpendicular to the pipe axis. During assembly, the threads are lubricated and Teflon tape is used for sealing. Aluminum witness plates (25.4 mm thick and 254 mm long) are used. They are stood vertically and the burn tubes are taped to the plates. Data from this experiment are an estimate of the number of fragments produced, depth and length of the dent in the witness plate, and the amount of unreacted explosive. The igniter consists of an M102 electric match inside a small latex bag with 1.50 g of black powder. This conforms closely to the RARDE design.

Figure 10 shows photographs of test results for two test firings on Formula #1. The fragments are shown, together with the witness plate and the inside of the barrette in which the test was conducted. An explosion occurred in both tests, but it was relatively mild. Not all of the explosive reacted; the photographs show significant fractions of the explosive adhering to the inside surface of the barrette and lying on the floor.

Formula #2 reacted much more violently in this test than Formula #1. This is shown in Figure 11. No unreacted explosive was recovered, the bombs were reduced to small fragments, and the witness plates were badly broken up.

These results are specific to this test configuration but are indicative of what might occur under other conditions. The planned weapon system will contain large quantities of explosive similar to that tested, and there will be some degree of confinement. These tests, using very small quantities of explosive compared with that planned for the final weapon configuration,

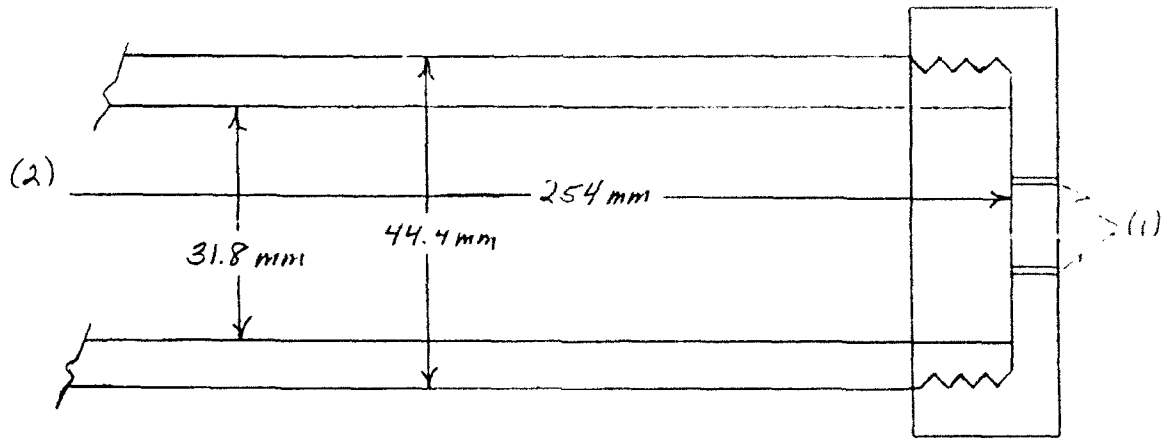

Note: (1) Holes for electric match lead wires.  
 (2) Both ends are identical except for the lead wire holes.

Figure 8. Test Cylinder for the RARDE Burn Tube Experiment.

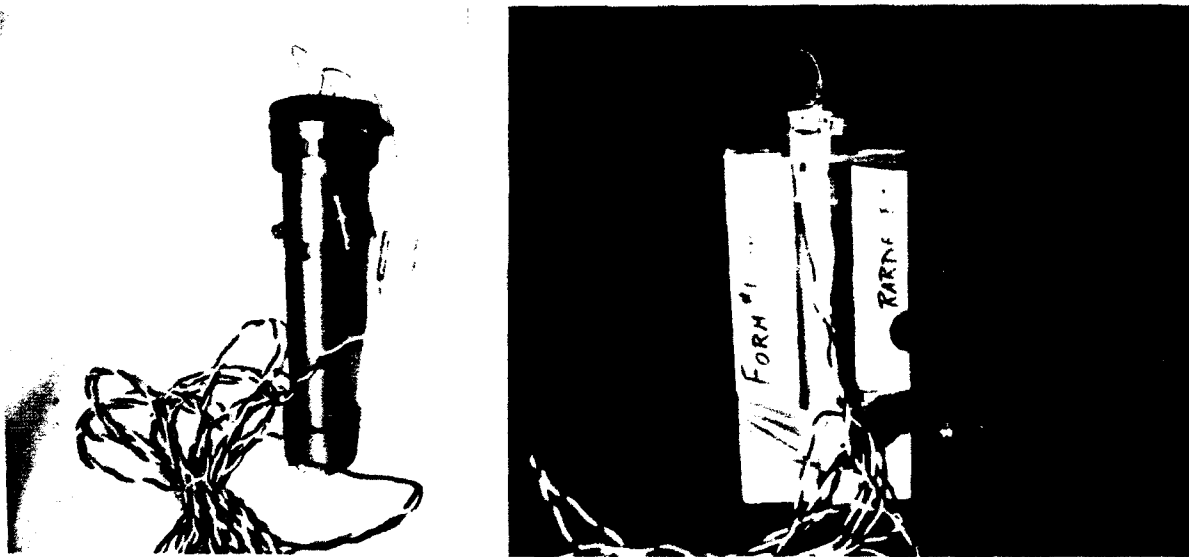

Note: (Mary/Dennis—photograph)  
 (Dennis—Data. See Section 4.4)

Figure 9. Test Configuration for RARDE Burn Tube Experiment.

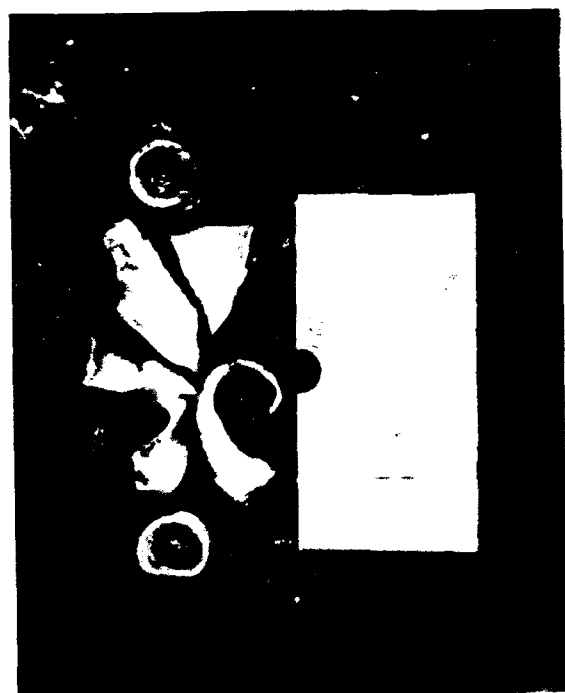
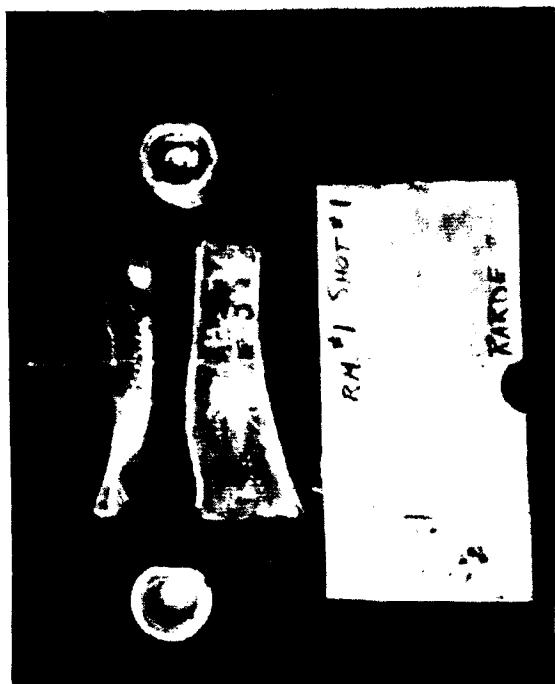

FORMULA #1  
SHOT #2  
20 OCT 92

Figure 10. Burn Tube Tests Results for Formula #1.

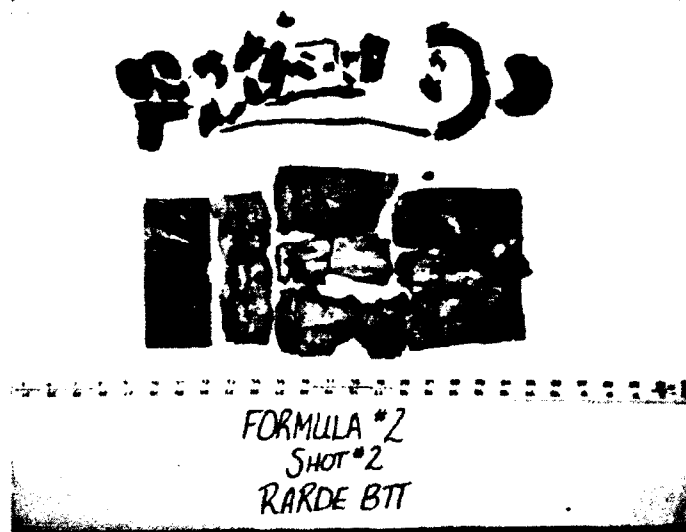
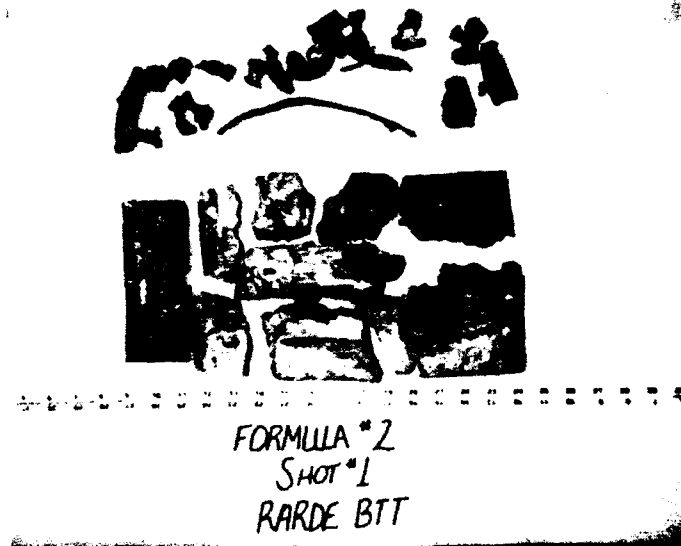

Figure 11. Burn Tube Tests Results for Formula #2.

indicate that the planned weapon would be very vulnerable to a single small ignition source, e.g., a small, hot fragment.

## 5. DISCUSSION

The test results were discussed in each section in the body of this report. It is worth stating that many of these results are not what were expected at the beginning of this research, and reiterating that the sensitivities that have been observed are very significant, to the extent that those working with these materials must exercise a degree of caution greater than required for normal work with secondary explosives. An appropriate comparison can be made with pyrotechnic compositions.

If these compositions are to be used in fielded systems, they must be desensitized and/or packaged in such a way as to shield them sufficiently from the hazards of the battlefield. They must also be made to satisfy the requirements for transportation and storage. To those ends, recommendations are made in Section 6.

## 6. FUTURE RESEARCH

This system in its final configuration must meet the Insensitive Munitions (IM) criteria. It must pass slow and fast cook-off; sympathetic detonation; fragment, bullet, and jet impact tests. In the process of meeting these requirements, it may be possible to reduce the (ESD) sensitivity.

It is recommended that the RDX be coated, thinly and uniformly, with a flame retardant material which, in turn, is coated with a shock desensitizing binder. Small percentages of graphite powder should be incorporated into the formulations to reduce ESD while at the same time promoting flowability and ease of discrete particle dissemination.

The flame retardant material will reduce cook-off susceptibility, and the binder will reduce sympathetic detonation and impact sensitivities. The research effort should emphasize the proper selection of the flame retardants and binder, and particularly the processes which must be developed or modified to apply these materials to the explosive particles.

Anticipated problems are aerodynamics and initiability of the ground layer of the modified particles. The modifications will likely inhibit the capability of the particles to be aerosolized. The larger particles will settle faster than before (considerably faster than the smaller ones) and even though the smaller particles settle faster than in their unmodified condition, reduction of the interval between the dissemination event and the initiation event should allow the desired concentration gradient to be established for proper functioning of the system.

INTENTIONALLY LEFT BLANK.

## 7. REFERENCES

- Dobratz, B. M., M. Finger, L. G. Green, J. R. Humphrey, R. R. McGuire, and H. F. Rizzo. "Selected Sensitivity Tests of Triaminotrinitrobenzene (TATB) Formulations and Their Evaluation." UCID-18026, Lawrence Livermore National Laboratory, Livermore, CA, 1979.
- Dyer, A. S., P. J. Hubbard, P. R. Lee, and D. G. Tisley. "Factors Affecting the Explosiveness of Munition Fillings." Proceedings of the Seventh Symposium on Detonation, pp. 1042-1047, June 1981.
- Gibbs, T. R., and A. Popolato. LASL Explosive Property Data. Berkeley, CA: University of California Press, 1980.
- Lindstrom, I. E. "Plane Shock Initiation of an RDX Plastic-Bonded Explosive." Journal of Applied Physics, vol. 37, no. 3, pp. 4873-4880, December 1964.
- NAVORD OD 44811, vol. 1, Naval Weapons Center, China Lake, CA, 1 January 1972.
- Pakulak, J. M., Jr., and S. Cragin. "Calibration of a Super Small-Scale Cook-off Bomb (SSCB) for Predicting Severity of the Cook-off Reaction." NWC TP 6414, NAWC, China Lake, CA, July 1983.
- Ramsey, J. B., and A. Popolato. "Analysis of Shock Wave and Initiation Data for Solid Explosives." Proceedings of the 4th Symposium (International), Office of Naval Research, ACR-126, pp. 233-238, Washington, 1965.
- Thomas, J. Probability and Statistics Branch, System Engineering and Concepts Analysis Division, U. S. Army Ballistic Research Laboratory, Aberdeen Proving Ground, MD, private communication.
- Wang, P. S., and G. F. Hall. "Friction, Impact, and Electrostatic Discharge Sensitivities of Energetic Materials." MLM-3252/UC-45, Mound, Miamisburg, OH, (performed for the DOE under Contract No. DE-AC04-76-DP00053), 31 May 1985.

INTENTIONALLY LEFT BLANK.

<u>No. of Copies</u>	<u>Organization</u>	<u>No. of Copies</u>	<u>Organization</u>
2	Administrator Defense Technical Info Center ATTN: DTIC-DDA Cameron Station Alexandria, VA 22304-6145	1	Commander U.S. Army Missile Command ATTN: AMSMI-RD-CS-R (DOC) Redstone Arsenal, AL 35898-5010
1	Commander U.S. Army Materiel Command ATTN: AMCAM 5001 Eisenhower Ave. Alexandria, VA 22333-0001	1	Commander U.S. Army Tank-Automotive Command ATTN: ASQNC-TAC-DIT (Technical Information Center) Warren, MI 48397-5000
1	Director U.S. Army Research Laboratory ATTN: AMSRL-OP-CI-AD, Tech Publishing 2800 Powder Mill Rd. Adelphi, MD 20783-1145	1	Director U.S. Army TRADOC Analysis Command ATTN: ATRC-WSR White Sands Missile Range, NM 88002-5502
1	Director U.S. Army Research Laboratory ATTN: AMSRL-OP-CI-AD, Records Management 2800 Powder Mill Rd. Adelphi, MD 20783-1145	1	Commandant U.S. Army Field Artillery School ATTN: ATSF-CSI Ft. Sill, OK 73503-5000
		(Class. only) 1	Commandant U.S. Army Infantry School ATTN: ATSH-CD (Security Mgr.) Fort Benning, GA 31905-5660
2	Commander U.S. Army Armament Research, Development, and Engineering Center ATTN: SMCAR-IMI-I Picatinny Arsenal, NJ 07806-5000	(Unclass. only) 1	Commandant U.S. Army Infantry School ATTN: ATSH-CD-CSO-OR Fort Benning, GA 31905-5660
2	Commander U.S. Army Armament Research, Development, and Engineering Center ATTN: SMCAR-TDC Picatinny Arsenal, NJ 07806-5000	1	WL/MNOI Eglin AFB, FL 32542-5000  <u>Aberdeen Proving Ground</u>
1	Director Benet Weapons Laboratory U.S. Army Armament Research, Development, and Engineering Center ATTN: SMCAR-CCB-TL Watervliet, NY 12189-4050	2	Dir, USAMSA ATTN: AMXSY-D AMXSY-MP, H. Cohen
(Unclass. only) 1	Commander U.S. Army Rock Island Arsenal ATTN: SMCRI-IMC-RT/Technical Library Rock Island, IL 61299-5000	1	Cdr, USATECOM ATTN: AMSTE-TC
1	Director U.S. Army Aviation Research and Technology Activity ATTN: SAVRT-R (Library) M/S 219-3 Ames Research Center Moffett Field, CA 94035-1000	1	Dir, ERDEC ATTN: SCBRD-RT
		1	Cdr, CBDA ATTN: AMSCB-CI
		1	Dir, USARL ATTN: AMSRL-SL-I
		10	Dir, USARL ATTN: AMSRL-OP-CI-B (Tech Lib)

<u>No. of</u> <u>Copies</u>	<u>Organization</u>	<u>No. of</u> <u>Copies</u>	<u>Organization</u>
1	C.I.A. OIR/DB/Standard GE47 HQ Washington, D.C. 20505	5	Commander U.S. Army Armament Munitions and Chemical Command ATTN: SMCAR-QAN-P, Mr. Henry Vandyke Picatinny Arsenal, NJ 07801-5000
1	Chairman DOD Explosives Safety Board Room 856-C Hoffman Bldg 1 2461 Eisenhower Avenue Alexandria, VA 22331	1	Director Missile and Space Intelligence Center ATTN: AIAMS-YDL Redstone Arsenal, AL 35898-5500
2	Commander U.S. Army Chemical and Biological Defense Agency Edgewood Research Development and Engineering Center ATTN: SCBRD-RT, Malecki Irvine Swahn Aberdeen Proving Ground, MD 21010-5423	1	Director U.S. Army Missile Command ATTN: AMSME-RK, Dr. R. G. Rhoades Redstone Arsenal, AL 35898
1	Commander U.S. Army Armament Research, Development, and Engineering Center ATTN: SMCAR-AEE, Dr. J. Lannon Bldg. 3022 Picatinny Arsenal, NJ 07806-5000	1	Director U.S. Army Missile Command ATTN: Bill Melvin Redstone Arsenal, AL 35898-5241
1	Commander U.S. Army Armament Research, Development, and Engineering Center ATTN: SMCAR-AEE, Dr. J. Lannon Bldg. 3022 Picatinny Arsenal, NJ 07806-5000	1	Commandant USAOMMCS ATTN: ATSK-CME, Mr. Steven J. Herman Redstone Arsenal, AL 35897-6500
5	Commander U.S. Army Armament Research, Development, and Engineering Center ATTN: SMCAR-AEE-W, Dr. N. Slagg Mike Joyce Charles Capuccino Dr. Jack Alster Richard Graybush Picatinny Arsenal, NJ 07806-5000	3	Commander Belvoir RD&E Center ATTN: STRBE-N, Dr. David Heberlein STRBE-NA, Dr. Herman Spitzer STRBE-NAN, Ms. Pamela Jacobs Fort Belvoir, VA 22060-5606
1	Commander U.S. Army Armament Munitions and Chemical Command ATTN: AMSMC-IMP-L Rock Island, IL 61299-7300	1	Director TRAC-WSMR ATTN: ATOR-TSL White Sands Missile Range, NM 88002-5502
1	Commander, USACECOM R&D Technical Library ATTN: ASQNC-ELC-IS-L-R, Myer Center Fort Monmouth, NJ 07703-5000	1	Commandant USAFAS ATTN: ATSF-TSM-CN Fort Sill, OK 73503-5600
1	Commander, USACECOM R&D Technical Library ATTN: ASQNC-ELC-IS-L-R, Myer Center Fort Monmouth, NJ 07703-5000	1	Commander U.S. Army Research Office ATTN: Chemistry Division P.O. Box 12211 Research Triangle Park, NC 27709-2211

<u>No. of</u> <u>Copies</u>	<u>Organization</u>
2	Office of Naval Research ATTN: Dr. A. Faulstick, Code 23 (2 cps) 800 N. Quincy Street Arlington, VA 22217-5000
1	Office of the Chief Naval Research ATTN: R. Miller, Code 473 800 N. Quincy Street Arlington, VA 22217-5000
1	Commander Naval Sea Systems Command ATTN: SEA 061, Dr. R. Bowen Washington, DC 20362
1	Commander Naval Explosive Ordnance Disposal Technology Center ATTN: Technical Library, Code 604 Indian Head, MD 20640
1	Commander Naval Research Laboratory ATTN: Code 6100 Washington, DC 20375
1	Commander Naval Surface Warfare Center ATTN: Code G13 Dahlgren, VA 22448-5000
1	Commander Naval Surface Warfare Center ATTN: Mr. L. Roslund, R10C Silver Spring, MD 20902-5000
1	Commander Naval Surface Warfare Center ATTN: Mr. M. Stosz, R10B Silver Spring, MD 20902-5000
1	Commander Naval Surface Warfare Center ATTN: Code X211, Lib Silver Spring, MD 20902-5000
1	Commander Naval Surface Warfare Center ATTN: R R Bernecker, R13 Silver Spring, MD 20902-5000

<u>No. of</u> <u>Copies</u>	<u>Organization</u>
1	Commander Naval Surface Warfare Center ATTN: J. W. Forbes, R13 Silver Spring, MD 20902-5000
1	Commander Naval Surface Warfare Center ATTN: S. J. Jacobs, R10 Silver Spring, MD 20902-5000
1	Commander Naval Surface Warfare Center ATTN: J. Short, R12 Silver Spring, MD 20902-5000
1	Commander Naval Surface Warfare Center ATTN: Carl Gotzmer Silver Spring, MD 20902-5000
1	Commander Naval Surface Warfare Center ATTN: Dr. Kurt Mueller, Code R10 Silver Spring, MD 20902-5000
1	Commander (Code 326) Naval Weapons Center ATTN: Dr. L. Smith China Lake, CA 93555
1	Commander (Code 385) Naval Weapons Center ATTN: Dr. R. Atkins China Lake, CA 93555
1	Commander (Code 388) Naval Weapons Center ATTN: Dr. R. Reed, Jr. China Lake, CA 93555
1	Commander (Code 3891) Naval Weapons Center ATTN: Dr. K. J. Graham China Lake, CA 93555
1	Commander Naval Weapons Center ATTN: Dr. R. Cramer China Lake, CA 93555

<u>No. of</u> <u>Copies</u>	<u>Organization</u>
1	Commander Naval Weapons Center ATTN: Dr. G. Lindsay China Lake, CA 93555
1	Commander (Code 3891) Naval Weapons Center ATTN: Dr. May Chan China Lake, CA 93555
1	Department of the Navy Naval Ordnance Station Indian Head Detachment ATTN: John A. Zehmer III, Code 46 Indian Head, MD 20640-5000
3	Department of the Navy Naval Ordnance Station Indian Head Detachment ATTN: Mr. G. Naufflett Mr. R. Farncomb Dr. S. Peters Indian Head, MD 20640-5000
1	Commander Fleet Marine Force, Atlantic ATTN: G-4 (NSAP) Norfolk, VA 23511
1	Commander Air Force Rocket Propulsion Laboratory ATTN: R. Geisler, Code AFRPL MKPA Edwards AFB, CA 93523
3	WL/MNME ATTN: Gary Parsons Thomas Floyd Stephen Struck Eglin AFB, FL 32542-5000
1	Commander Ballistic Missile Defense Advanced Technology Center ATTN: Dr. David C. Sayles P.O. Box 1500 Huntsville, AL 35807

<u>No. of</u> <u>Copies</u>	<u>Organization</u>
3	Commanding Officer Iowa Army Ammunition Plant ATTN: Peter A. Richardson Kevin J. Hovden Thomas J. Rowan Mason & Hanger/Silas Mason Co., Inc. Middletown, IA 52638-9701
4	Director Lawrence Livermore National Laboratory University of California ATTN: Dr. M. Finger Dr. Raymond McGuire Kenneth Scribner Lee Frahm P.O. Box 808 Livermore, CA 94550
5	Director Los Alamos National Laboratory ATTN: Mr. J. Ramsey Mary Stinecipher Kien-Yin Lee Brigitta Dobratz Dr. Howard Cady P.O. Box 1663 Los Alamos, NM 87545
1	Director Sandia National Laboratories ATTN: Dr. E. Mitchell, Supervisor Division 2513 P.O. Box 5800 Albuquerque, NM 87185
1	Director Sandia National Laboratories ATTN: Dr. Robert Carling Livermore, CA 94557-0096
1	Holston Army Ammunition Plant ATTN: Mr. Charles Smith Bldg. 8 West Stone Drive Kingsport, TN 37660

No. of  
Copies Organization

1 Idos Corporation  
ATTN: Irving B. Akst  
P. O. Box 285  
Pampa, TX 79066-0285

Aberdeen Proving Ground

1 Cdr, CRDEC, AMCCOM  
ATTN: SMCCR-OPP, C. Hassell

5 Cdr, USACSTA  
ATTN: STECS-AA-HT, Mr. Gary Appel