

AD-A265 207



FASTC-ID(RS)T-0241-93

2

# FOREIGN AEROSPACE SCIENCE AND TECHNOLOGY CENTER

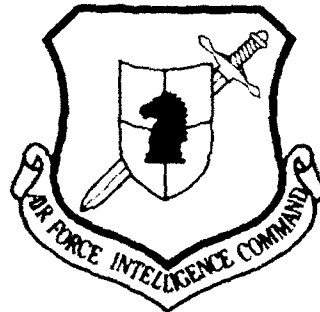

REACTOR FOR CONDUCTING PROCESSES IN A "FLUIDIZED" BED

by

D.D. Logvinenko

DTIC  
ELECTE  
JUN 03 1993  
S B D



Approved for public release;  
Distribution unlimited.



93 6 02 024

93-12419



## HUMAN TRANSLATION

FASTC-ID(RS)T-0241-93 6 May 1993

MICROFICHE NR: 93C000309

REACTOR FOR CONDUCTING PROCESSES IN A "FLUIDIZED" BED

By: D.D. Logvinenko

English pages: 2

Source: Russian Patent Nr. 168264, 18 November  
1965; pp. 1-2

Country of origin: USSR

Translated by: Sgt Tama L. Carstensen

Requester: OLAC PL/STSC/Roger H. Gerzeski

Approved for public release; Distribution unlimited.

THIS TRANSLATION IS A RENDITION OF THE ORIGINAL FOREIGN TEXT WITHOUT ANY ANALYTICAL OR EDITORIAL COMMENT STATEMENTS OR THEORIES ADVOCATED OR IMPLIED ARE THOSE OF THE SOURCE AND DO NOT NECESSARILY REFLECT THE POSITION OR OPINION OF THE FOREIGN AEROSPACE SCIENCE AND TECHNOLOGY CENTER.

PREPARED BY:  
TRANSLATION DIVISION  
FOREIGN AEROSPACE SCIENCE AND  
TECHNOLOGY CENTER  
WPAFB, OHIO

U. S. BOARD ON GEOGRAPHIC NAMES TRANSLITERATION SYSTEM

Block	Italic	Transliteration	Block	Italic	Transliteration
А а	<i>А а</i>	A, a	Р р	<i>Р р</i>	R, r
В в	<i>В в</i>	B, b	С с	<i>С с</i>	S, s
В в	<i>В в</i>	V, v	Т т	<i>Т т</i>	T, t
Г г	<i>Г г</i>	G, g	У у	<i>У у</i>	U, u
Д д	<i>Д д</i>	D, d	Ф ф	<i>Ф ф</i>	F, f
Е е	<i>Е е</i>	Ye, ye; E, e*	Х х	<i>Х х</i>	Kh, kh
Ж ж	<i>Ж ж</i>	Zh, zh	Ц ц	<i>Ц ц</i>	Ts, ts
З з	<i>З з</i>	Z, z	Ч ч	<i>Ч ч</i>	Ch, ch
И и	<i>И и</i>	I, i	Ш ш	<i>Ш ш</i>	Sh, sh
Й я	<i>Й я</i>	Y, y	Щ щ	<i>Щ щ</i>	Shch, shch
К к	<i>К к</i>	K, k	Ъ ъ	<i>Ъ ъ</i>	"
Л л	<i>Л л</i>	L, l	Ы ы	<i>Ы ы</i>	Y, y
М м	<i>М м</i>	M, m	Ь ь	<i>Ь ь</i>	'
Н н	<i>Н н</i>	N, n	Э э	<i>Э э</i>	E, e
О о	<i>О о</i>	O, o	Ю ю	<i>Ю ю</i>	Yu, yu
П п	<i>П п</i>	P, p	Я я	<i>Я я</i>	Ya, ya

\*ye initially, after vowels, and after ъ, ь; e elsewhere.  
When written as ѣ in Russian, transliterate as yě or ě.

RUSSIAN AND ENGLISH TRIGONOMETRIC FUNCTIONS

Russian	English	Russian	English	Russian	English
sin	sin	sh	sinh	arc sh	sinh <sup>-1</sup>
cos	cos	ch	cosh	arc ch	cosh <sup>-1</sup>
tg	tan	th	tanh	arc th	tanh <sup>-1</sup>
ctg	cot	cth	coth	arc cth	coth <sup>-1</sup>
sec	sec	sch	sech	arc sch	sech <sup>-1</sup>
cosec	csc	csch	csch	arc csch	csch <sup>-1</sup>

Russian English

rot curl  
lg log

GRAPHICS DISCLAIMER

All figures, graphics, tables, equations, etc. merged into this translation were extracted from the best quality copy available.

DTIC QUALITY INSPECTED 2

Accession For	
NTIS GRA&I	<input checked="" type="checkbox"/>
DTIC TAB	<input type="checkbox"/>
Unannounced	<input type="checkbox"/>
Justification	
By _____	
Distribution/	
Availability Codes	
Dist.	Avail and/or Special
A-1	

## REACTOR FOR CONDUCTING PROCESSES IN A "FLUIDIZED" BED

Invention author D. D. Logvinenko

Applicant -

---

PUBLICATION OF PATENT № 168264

Dependent on Author's Certificate № -

Applied 25 Oct 1963 (№ 863034/23-4)

with the attachment of application № -

Priority -

Published 18 February 1965 Bulletin № 4

Date of patent specification publication 16 Mar 1965

---

Certain reactors for conducting processes in a "fluidized" bed are made up of a body and housing in which a cooling agent (for example) circulates. The "fluidized" bed in these devices is created either by means of a gas flowing through a gas-diffusion barrier or mechanically by the rotation of a blade system (or fan), or in a centrifugal force field by creating a certain organization in the rotating flow of the fluidized medium.

The (distinguishing) feature of the proposed reactor is that it is made of a nonmagnetic nonconductive material housed within a stator with a rotating magnetic field. The processed material (nickel, for example) becomes fluidized.

This makes it possible to process ferromagnetic materials at elevated pressures, in a vacuum, in the gas phase and in a fluid; to process particles without the loss of small particles from the processing zone.

The proposed reactor is schematically represented in the diagram.

Reactor body (1) is made of nonmagnetic nonconductive material. In design stator (2) is similar to the stator of a asynchronous induction motor. A cooling agent is circulated inside jacket (3). Liquid or gas is fed through connecting pipe (4) to the reactor; a powder, nickel for example, is supplied through connecting pipe (5). Connecting pipe (6) connects the pipe to the vacuum pump, while connecting pipe (7) removes the reaction products.

A rotating magnetic field with a strength of 1-100 Oe (depending on the degree of dispersion of the solid ferromagnetic material, the diameter of the reactor, etc...) is created in stator 2. Particles of the ferromagnetic material when exposed to the magnetic field perform rapid rotating motions about their axes or vibrate and simultaneously move in a circle around the walls of the reactor body. These particles become fluidized. Fine particles of ferromagnetic material are retained in the magnetic field, which allows gas or liquid to pass through the reactor at high speed without loss of the ferromagnetic material from the reactor, thereby guaranteeing the continuity of the process. The reactor can be used in the chemical industry for conducting reactions, with nickel or iron catalysts for example, or as a cementer for cleaning electrolytes, etc...

#### Objective of the Invention

The reactor for conducting processes in a "fluidized" bed consists of a body and a housing through which a cooling agent circulates. Its distinguishing feature is that, for the purpose of standardizing the processes in the "fluidized" bed, the body is made of a nonmagnetic nonconductive material inside a stator with a rotating magnetic field.

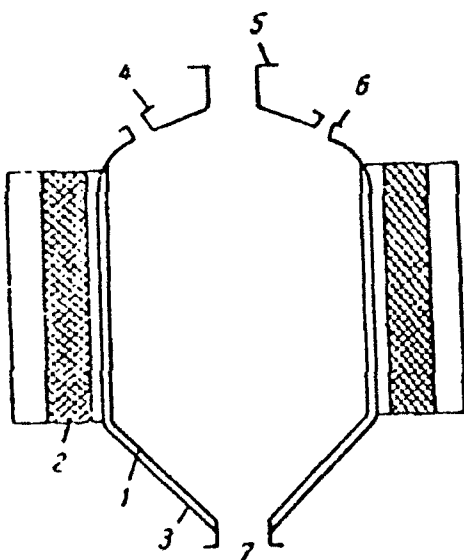

DISTRIBUTION LIST

DISTRIBUTION DIRECT TO RECIPIENT

<u>ORGANIZATION</u>	<u>MICROFICHE</u>
B085 DIA/RTS-2FT	1
C509 BALLOC509 BALLISTIC RES LAB	1
C510 R&T LABS/AVFADCOM	1
C513 ARRADCOM	1
C535 AVRADCOM/TSARCOM	1
C539 TRASANA	1
Q592 FSTC	4
Q619 MSIC REDSTONE	1
Q008 NTIC	1
Q043 AFMIC-IS	1
E051 HQ USAF/INET	1
E404 AEDC/DOF	1
E408 AFWL	1
E410 ASDTC/IN	1
E411 ASD/FTD/TTIA	1
E429 SD/IND	1
P005 DOE/ISA/DDI	1
P050 CIA/OCR/ADD/SD	2
1051 AFTT/LDE	1
PO90 NSA/CDB	1
2206 FSL	1

Microfiche Nbr: FTD93C000309  
FTD-ID(RS)T-0241-93