



March 1993

NCEL

By
Hugh G. Thomson

Technical Note

Sponsored by
Naval Facilities Engineering Command

CONSTRUCTION DIVER LIFT SYSTEMS

ABSTRACT A diver-operated lift system has been developed for underwater construction divers. The system consists of three different open-bottom lift bags with the following lift ranges: 200 to 550 pounds, 500 to 1,250 pounds, and 1,000 to 3,000 pounds. The system maintains a constant buoyancy during ascent by venting the expanding air volume out under the slider of a zipper, which is attached to the side of the bag along the vertical direction. A diver-operated air wand is used to compensate for compression of the air volume during descent. The system is easy to maintain, and most repairs can be performed by the users in the field. This report documents the development, test, and evaluation of the engineering model systems.

DTIC
ELECTE
S D
JUN 11 1993

93-13088



NAVAL CIVIL ENGINEERING LABORATORY PORT HUENEME CALIFORNIA 93043-4328

Approved for public release; distribution is unlimited

93 6 10 04 7

METRIC CONVERSION FACTORS

Approximate Conversions to Metric Measures				Approximate Conversions from Metric Measures			
Symbol	When You Know	Multiply by	To Find	Symbol	When You Know	Multiply by	To Find
in	inches	2.5	centimeters	mm	millimeters	0.04	inches
ft	feet	30	centimeters	cm	centimeters	0.4	inches
yd	yards	0.9	meters	m	meters	3.3	feet
mi	miles	1.6	kilometers	km	meters	1.1	yards
					kilometers	0.6	miles
in ²	square inches	6.5	square centimeters	cm ²	square centimeters	0.16	square inches
ft ²	square feet	0.09	square meters	m ²	square meters	1.2	square yards
yd ²	square yards	0.8	square meters	km ²	square kilometers	0.4	square miles
mi ²	square miles	2.6	square kilometers	ha	hectares (10,000 m ²)	2.5	acres
	acres	0.4	hectares				
oz	ounces	28	grams	g	grams	0.035	ounces
lb	pounds	0.45	kilograms	kg	kilograms	2.2	pounds
	short tons	0.9	tonnes	t	tonnes (1,000 kg)	1.1	short tons
	(2,000 lb)						
tsp	teaspoons	5	milliliters	ml	milliliters	0.03	fluid ounces
Tbsp	tablespoons	15	milliliters	l	liters	2.1	pints
fl oz	fluid ounces	30	milliliters	l	liters	1.06	quarts
c	cups	0.24	liters	l	liters	0.26	gallons
pt	pints	0.47	liters	m ³	cubic meters	35	cubic feet
qt	quarts	0.95	liters	m ³	cubic meters	1.3	cubic yards
gal	gallons	3.8	liters	oC	Celsius temperature	9/5 (then add 32)	Fahrenheit temperature
ft ³	cubic feet	0.03	cubic meters				
yd ³	cubic yards	0.76	cubic meters				
oF	Fahrenheit temperature	5/9 (after subtracting 32)	Celsius temperature				

* 1 in = 2.54 (exactly). For other exact conversions and more detailed tables, see NBS Misc. Publ. 286, Units of Weights and Measures, Price \$2.25, SD Catalog No. C13.10.286.

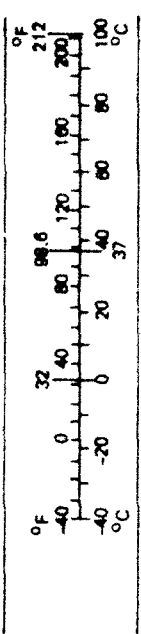

REPORT DOCUMENTATION PAGE			Form Approved OMB No. 0704-018	
Public reporting burden for this collection of information is estimated to average 1 hour per response, including the time for reviewing instructions, searching existing data sources, gathering and maintaining the data needed, and completing and reviewing the collection of information. Send comments regarding this burden estimate or any other aspect of this collection information, including suggestions for reducing this burden, to Washington Headquarters Services, Directorate for Information and Reports, 1215 Jefferson Davis Highway, Suite 1204, Arlington, VA 22202-4302, and to the Office of Management and Budget, Paperwork Reduction Project (0704-0188), Washington, DC 20503.				
1. AGENCY USE ONLY (Leave blank)		2. REPORT DATE March 1993		3. REPORT TYPE AND DATES COVERED Final; October 1983 - September 1988
4. TITLE AND SUBTITLE CONSTRUCTION DIVER LIFT SYSTEMS			5. FUNDING NUMBERS PR - YF60.534.091.01. 412	
6. AUTHOR(S) Hugh G. Thomson				
7. PERFORMING ORGANIZATION NAME(S) AND ADDRESS(ES) Naval Civil Engineering Laboratory 560 Laboratory Drive Port Huene, CA 93043-4328			8. PERFORMING ORGANIZATION REPORT NUMBER TN-1854	
9. SPONSORING/MONITORING AGENCY NAME(S) AND ADDRESS(ES) Naval Facilities Engineering Command 200 Stovall Street Alexandria, VA 22332-5307			10. SPONSORING/MONITORING AGENCY REPORT NUMBER	
11. SUPPLEMENTARY NOTES				
12a. DISTRIBUTION/AVAILABILITY STATEMENT Approved for public release; distribution is unlimited.			12b. DISTRIBUTION CODE	
13. ABSTRACT (Maximum 200 words) A diver-operated lift system has been developed for underwater construction divers. The system consists of three different open-bottom lift bags with the following lift ranges: 200 to 550 pounds, 500 to 1,250 pounds, and 1,000 to 3,000 pounds. The system maintains a constant buoyancy during ascent by venting the expanding air volume out under the slider of a zipper, which is attached to the side of the bag along the vertical direction. A diver-operated air wand is used to compensate for compression of the air volume during descent. The system is easy to maintain, and most repairs can be performed by the users in the field. This report documents the development, test, and evaluation of the engineering model systems.				
14. SUBJECT TERMS Lift system, open-bottom lift bags, dump valve, air-filled valve, air-filled wand			15. NUMBER OF PAGES 35	
			16. PRICE CODE	
17. SECURITY CLASSIFICATION OF REPORT Unclassified	18. SECURITY CLASSIFICATION OF THIS PAGE Unclassified	19. SECURITY CLASSIFICATION OF ABSTRACT Unclassified	20. LIMITATION OF ABSTRACT UL	

CONTENTS

	Page
INTRODUCTION	1
BACKGROUND	1
ADVANCED DEVELOPMENT MODEL (ADM)	2
System Description	3
Laboratory Tests	5
Ocean Tests	8
Conclusions and Recommendations from ADM Testing	9
ENGINEERING DEVELOPMENT MODEL (EDM)	10
EDM System Description	10
Reliability Tests	13
Inverted Bag Test	19
At-Sea Tests	19
Results of EDM Tests	25
USER TESTS	25
CONCLUSIONS	27
RECOMMENDATIONS	27
REFERENCES	28
APPENDIX - Test and Evaluation Master Plan	A-1

DTIC QUALITY INSPECTED

Accession For	
NTIS GRA&I	<input checked="" type="checkbox"/>
DTIC TAB	<input type="checkbox"/>
Unannounced	<input type="checkbox"/>
Justification	
By _____	
Distribution/ _____	
Availability Codes	
Dist	Avail and/or Special
A-1	

INTRODUCTION

Under the sponsorship of the Naval Facilities Engineering Command (NAVFAC), the Naval Civil Engineering Laboratory (NCEL) has developed a diver lift system for use by the Naval Underwater Construction Teams (UCTs). The system consists of three different open-bottom lift bags with the following lift ranges: 200 to 550, 500 to 1,250, and 1,000 to 3,000 pounds. The J.W. Automarine 220-pound lift bag with dump valve control was adequate in the 0- to 220-pound load range.

Diver control of the buoyant force is obtained by using a vertical zipper (running the height of the lift bag), an air wand (to add air), and a diaphragm-type dump valve. During ascent, the expanding volume of air is vented out of the lift bag under the zipper slider. During descent, the air wand is used to compensate for the shrinking air volume. The dump valve allows the diver to rapidly exhaust air from the lift bag.

Attributes of the diver lift system include simple and easy control of the buoyancy force with minimal logistic support requirements beyond levels currently experienced with commercially available open-bottom lift bags. This report documents the development of the NCEL diver lift system and provides documentation to support the production milestone decision.

BACKGROUND

Many UCT tasks require precise movement and positioning of heavy objects underwater. Diver-operated lift bags frequently are used as an alternative to surface-supported load lines. These lift devices range in complexity from simple open-bottom lift bags to microprocessor controlled lift systems. Reference 1, "A Zero Milestone Report on Construction Diver Lift Systems," contains a review of the state-of-the-art and technology opportunities in diver lift systems. This study identified several commercially available opened- and closed-bottom lift bags. In addition, several experimental systems were identified, including fixed-displacement lift bags, variable buoyancy (zipper) lift bags, microprocessor controlled systems, an analog air control system for open-bottom lift bags, and a pressure regulated closed lift system.

In FY83, tests and evaluation of both commercially available and experimental lift bag systems were conducted under contract by the Marine Technology Department at Santa Barbara City College (SBCC). These tests were conducted by the students and faculty at SBCC under the guidance of NCEL. The test results, documented in Reference 2, showed:

1. The lifting force of commercially available open bottom lift bag systems with lifting capacities greater than 250 pounds is difficult to control and potentially hazardous. Lift bags with dump valve operation were difficult to operate with near capacity loads due to the large pressure differential across the valve. In addition, due to poor construction techniques, some manufacturers' lift bags were unsuitable for UCT use.

2. Experimental lift bags using a vertical zipper for venting expanding air demonstrated the potential for good control of the buoyant force on small capacity lift bags (up to 750 pounds). Although tests of these lift bags validated the zipper control concept, these bags require

modification for practical application by the UCTs. One shortfall of these bags is that, even after the zipper is fully opened, a residual amount of air remains in the top of the bag. This makes it difficult to transfer loads on the seafloor since the zipper does not completely deflate the bag. Also, the zipper is often difficult to operate, requires maintenance after each use, and is expected to be a high failure rate component of this system.

3. The adjustable fixed-displacement lift bag provides excellent ascent and descent control of large payloads. However, overall control is degraded due to the bulky nature of the umbilicals and control manifold. Also, in comparison to simple open-bottom lift bags, the complexity of this system may reduce overall reliability and significantly increase logistic support requirements.

Based on these results, it was recommended by NCEL (Ref 3) that NAVFAC pursue one of two development options. The first option would provide the construction diver with improved lift bags for three different lift ranges between 200 and 3,000 pounds. The control mechanism for each lift bag is listed below under the appropriate lift ranges.

<u>Lift Range</u>	<u>Control Mechanism</u>
200 - 550 lb	Diver operated dump valve
500 - 1,250 lb	Diver operated dump valve with control zipper
1,000 - 3,000 lb	Diver operated dump valve with control zipper

The second option would provide the construction diver with a completely stable lift bag for lifts ranging from 2,000 to 10,000 pounds. This lift system would utilize the variable fixed displacement lift bag with an improved diver operated control system.

The first development option above was pursued, with further lift system requirements provided by NAVFAC (Ref 4). Specific objectives of this development effort are outlined in the Test and Evaluation Master Plan (TEMP) thresholds (Appendix A). These include the development of a simple, controllable, underwater lift system limited to the 50- to 3,000-pound range. This report documents this development effort.

ADVANCED DEVELOPMENT MODEL (ADM)

The advanced development model diver lift system was designed and fabricated under contract by Eastport International, Inc. This system, described below, consisted of three different sized lift bags between 0- to 3,000-pound lift capacity. From June through September 1986, laboratory and ocean tests of the diver lift system were conducted at NCEL and offshore Anacapa Island. These tests were conducted to assess system performance, determine general physical characteristics, and identify any safety or human factors deficiencies. The results of these tests are documented in the following sections.

System Description

The system consists of three lift bags, one for each of the following lift ranges: (1) 200 to 550 pounds; (2) 500 to 1,250 pounds; and (3) 1,000 to 3,000 pounds. These bags are open-bottom with a tear-drop shape (similar to J.W. Automarine and Subsvalve lift bags), and contain an iris diaphragm dump valve, control zippers, load lifting bridles, and convenience handles. The bags, fabricated under subcontract by Subsvalve, are made of a heavy-weight polyester fabric that is coated with PVC. The gores of the bag are joined by a bonding process that uses an adhesive and curing of the seam under pressure and heat (a vulcanizing process). This process is reported by the manufacturer (Subsvalve) to provide a bond that exceeds the strength of the fabric material without stitching (thereby reducing the number of potential leak paths).

The iris diaphragm valve selected for use as a dump valve is a modified commercially available valve manufactured by Kemutec Inc of Bristol, PA. The stock valve, shown in Figure 1, is hand-actuated and is designed primarily for use as a shut-off valve for fine powders. It consists of a valve housing (or body), a rotating ring, and a diaphragm. The diaphragm is basically a sleeve, and is attached at one end to the housing and at the other end to the rotating ring. As the ring is rotated within the housing, the orifice of the diaphragm is varied from a closed position to the inside diameter of the sleeve.

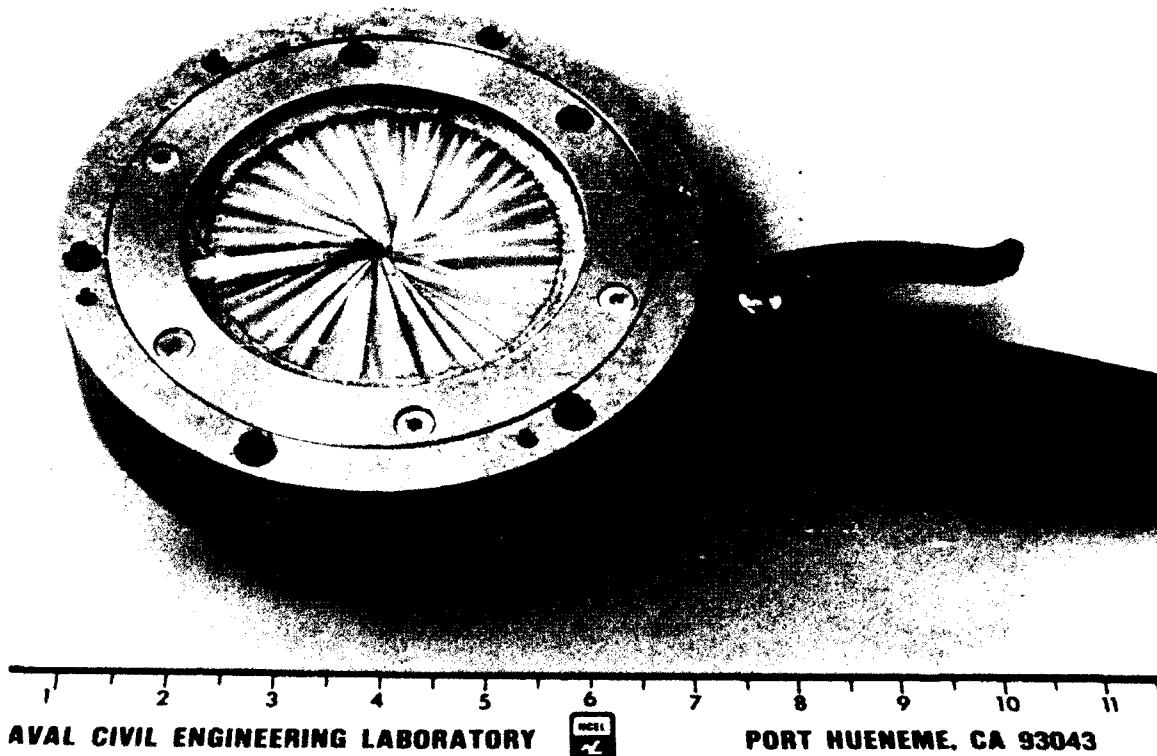

Figure 1. Kemutec Inc. diaphragm valve.

Modifications required to integrate this valve into the diver lift system included:

1. Changing the rotary motion required with the handle to the linear motion of the lanyard.
2. Providing a means for attaching the valve to the lift bag.
3. Modifying the valve for "normally closed" operation.

In order to minimize the cost associated with refabricating components of the dump valve, many components from the commercial valve were used for the test program. Although this would require increased maintenance during testing (due to the material combination), this approach was selected since it provided a cost effective verification of the diaphragm dump valve concept. Any future valve design (beyond the advanced development system) would require materials suitable for use in the ocean environment.

Figure 2 is an assembly drawing of the modified valve. To provide linear actuation of the valve, the lanyard is attached directly to the lever of the rotating ring and rides around the outside of the rotating ring and over a pulley. The end of the lanyard is attached to an aluminum handle at the skirt of the lift bag for operation by divers. To provide normally closed operation, an arm connecting a torsion spring to the rotating ring was added. The arm, spring loaded in the closed position, rotates about the shaft (which is attached to the housing) on a Delrin bushing.

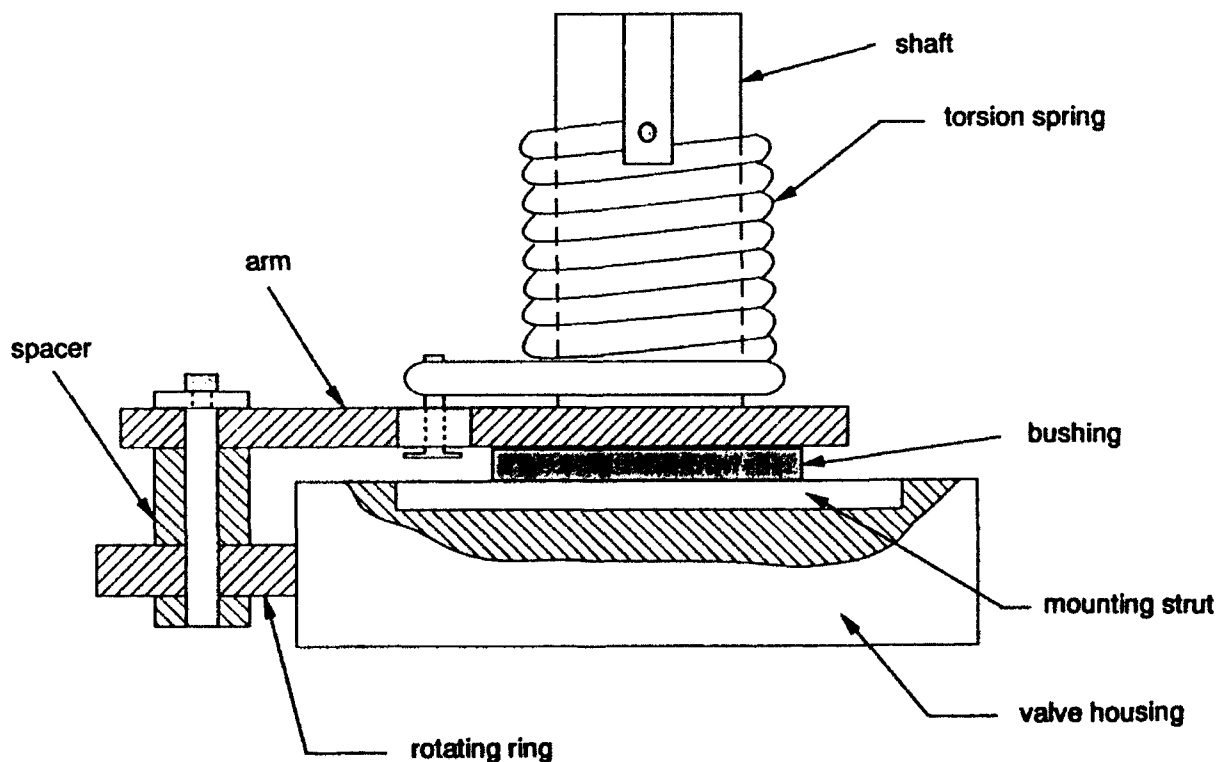

Figure 2. Modified valve.

The valve/bag attachment consists of a split collar assembly that, when threaded together, captures a lip of the bag fabric around the opening for the valve. The body of the valve is used as the inside half of the split collar assembly. The lip, used to help capture the bag inside the collar, was fabricated by bonding an additional ring of fabric material around the opening on the inside of the lift bag.

The load lifting bridle is fabricated from stainless steel and contains four "D" rings for attaching a load lifting line through the bag and load handling slings. The slings are made of 1-inch Kevlar rope and are attached to the "D" rings with safety shackles.

The control zipper (called an Omni Environmental Barrier Slide Fastener) is manufactured by Talon Inc. in Meadville, PA. The zipper, made of a neoprene-coated nylon and nickel-silver alloy, is also used on survival suits as well as on both dry and wet suits for divers. The manufacturer recommends that a paraffin wax be used occasionally to lubricate and maintain the zipper.

Spanning the opening for the zipper on the inside of the bag is a strength member consisting of a strip of polyester fabric (the same material as the bag) with one vertical line of 1/2-inch holes located on 1-1/2-inch centers. The function of the strength member is to constrain the opening for the zipper, thus allowing easy operation of the zipper and insuring that the bag does not spread (at the zipper opening) and push the zipper open.

To provide air for inflating the lift bags, a diver controlled squirt valve (similar to the valve used at gas stations to inflate tires) was rigged to 150 feet of 1/2-inch hose. A 2-foot wand was attached to the end of the valve to aid in directing the air into the bag.

Laboratory Tests

A series of laboratory tests was conducted to provide an initial evaluation of the diver lift system and prepare the system for ocean tests. These tests included operation of the dump valve and control zipper, and general inspection of the lift system hardware.

To evaluate the iris dump valve and identify a suitable diaphragm material, a test fixture was built to simulate the operation of the dump valve on a lift bag underwater. The test fixture is a cylindrical chamber fabricated from PVC. The dump valve mounts to the top of the chamber. Air pressure is applied through an inlet via a pressure regulator, and monitored with 0-10 psi pressure gage. With the dump valve closed, the chamber is sealed to a maximum pressure of 7 psi (a check valve provides the pressure relief).

Two diaphragm materials were selected for evaluation with the dump valve: a polyurethane-coated nylon and a natural rubber. Both materials were reported by the manufacturer to be waterproof. Initial inspection and operation of the valve with each material indicated:

1. The nylon diaphragm is non-elastic and twists tight into a closed position with only a very small force applied to the valve.
2. The rubber diaphragm is very elastic and requires two to three times more force than the nylon to twist closed. Also, because the rubber material stretches as it is rotated, it tends to want to rest in the normally open position.

To test the ability of the diaphragms to seal, the valve was placed in the test fixture and submerged in a tank of water. Pressure was applied to the valve in the closed position and any leaks were noted. The valve was actuated (opened) several times while submerged, then once again checked for leaks.

In addition to sealing tests, the force required to open the valves was recorded. These data were recorded by attaching a 0 to 20-pound load measurement scale (spring type) on the lanyard and slowly pulling up to open the valve. These tests were conducted at least five times for each diaphragm.

The tests results showed:

1. The polyurethane-coated nylon diaphragm (as manufactured) leaked, but required less force to open. The leaks were in the stitching of the seams (the fabric material itself appeared to seal well). In an effort to seal the seams well enough to verify the overall design concept, a coating of liquid seam sealer was applied over the stitching. This dramatically slowed the leakage. However, as the valve sleeve was stretched tight in the closed position, the stitching holes also stretched - allowing a small amount of air to pass. This leakage was considered minor to conduct ocean tests for verification of the valve concept. Any future designs with this diaphragm would incorporate bonded rather than stitched seams.

2. The rubber diaphragm bulged under pressure but remained sealed with additional pretensioning of the torsion spring (beyond what is used with the nylon diaphragm). Since the rubber diaphragm was elastic, it required more torque than the nylon diaphragm to twist closed. It also tended to realign itself in the open position (releasing energy stored in the elastic), thereby behaving like a normally open valve. To compensate for this effect, a torsion spring of greater spring rate was incorporated on the valve.

The forces required to actuate the valve with the nylon and rubber diaphragms are listed in Table 1. These data show an average of 10 and 11 pounds for the nylon and rubber diaphragms, respectively. Although these values are beyond the original design goal of 5 to 7 pounds, it was determined that a properly designed handle on the end of the lanyard would ease the actuation of the valve.

To provide an initial assessment of the zipper, tests were conducted operating each zipper through a minimum of 50 cycles (one cycle is defined as opening and closing the zipper). No operational problems were encountered during these tests. However, it was noted that, due to the stiffness of the zipper, its operation might be considered two-handed since it was eased by grasping a convenience handle with the free hand. The stiffness was not considered excessive considering that, once the zipper position is set, it should remain in place.

Table 1
Valve Operational Pull Forces

Polyurethane Coated Nylon Fabric Diaphragm	
Test No.	Pull Force^a (lb)
1	12
2	9
3	10
4	10
5	9
Natural Rubber Diaphragm	
Test No.	Pull Force^b (lb)
1	11
2	13
3	10
4	11
5	11

^aAverage Pull Force = 10 lb

^bAverage Pull Force = 11 lb

Detailed inspection of the lift system components indicated that, while the system appears very durable, the lift bridle should be redesigned to reduce weight and bulkiness. In addition, the four-sling lifting arrangement should be replaced with an arrangement of three Kevlar slings of smaller diameter. This should improve handling and performance, since it will reduce the number of slings and insure uniform loading of the slings and bridle.

Ocean Tests

To evaluate the control features of the diver lift system at sea, tests were conducted offshore Anacapa Island. These tests, consisting of hover, ascent, descent, and porpoise tests (uncontrolled ascent), were conducted in approximately 60 feet of water. The lift bags were outfitted with the following dump valves:

200 - 550 lb lift bag	4-inch nylon diaphragm
500 - 1,250 lb lift bag	4-inch rubber diaphragm
1,000 - 3,000 lb lift bag	6-inch rubber diaphragm

Diver support was provided by the NCEL dive locker. Concrete clumps weighing between 200 and 2,000 pounds were used as the test loads.

The test procedure consisted of operating the lift system in all operating modes using test loads of approximately minimum, 50 percent, and 100 percent rated capacity of each bag (e.g., for the small bag, 200-, 300-, and about 550-pound weights were used). The test series was conducted using the smallest bag first in the following sequence: hover, ascent, descent, uncontrolled ascent. The hover mode was conducted first in each series of tests, since this was the easiest and safest mode with which to become familiar with each bag. In many cases, the lift bags (with test loads) were used in the ascent/descent modes several times to practice and gain familiarity.

The results of these tests indicated:

1. Controlled hover and ascent were obtained by using the control zipper. The larger lift bags with control zippers were easier to control than the small lift bag that does not have the control zipper. Divers commented that controlled hovering at depths of 60 feet or more could be done easier once the zipper was properly adjusted. The adjustment of the zipper (to obtain neutral or slightly negative buoyancy) required some patience and judgment since it was an interactive process of setting the slide, adding air, and assessing the net weight of the system (normally by trying to lift the clump). Controlled ascents were obtained by adjusting the zipper to neutral buoyancy, grasping one of the convenience handles, and swimming the bag up to the desired depth of water. In one case, one set of divers conducted a completely controlled ascent of the 1,250-pound lift bag from the seafloor (about 60-foot depth) to within 10 to 15 feet of the surface, where they hovered for about 2 minutes before attempting a controlled descent. However, with the zipper/strength member located behind the zipper, the air volume in the bag could increase faster than the zipper opening could vent it. This was primarily because the zipper and strength member were too restrictive to allow total and instantaneous venting of a rapidly expanding air volume. In some tests, to avoid an uncontrolled ascent, the divers used the dump valve to vent air that the zipper could not relieve quickly enough. In these cases, the diver was able to determine when and how long to open the dump valve by observing the level of bubble activity underneath the zipper slide.

2. The iris dump valve provided quick and easy exhaust of the air volume. Divers commented that, in comparison to the standard poppet type commercial dump valves, the iris dump valve is smoother and easier to operate, and is also much quieter. The Automarine commercial valve makes a loud gurgling sound when air passes through the orifice. However, because of the relative ease of operation and lack of noise (when exhausting air), many divers

were not sure how much air was exhausting out the valve without watching it directly. Coupled with the relatively slow response time of the lift bag to the dumping action of the valve (due to large inertial forces of the system), the smooth and easy operation of the valve may have a tendency to overcompensate for changes in buoyancy. A combination of increased spring tension and training is expected to provide suitable dump valve operation.

3. When a descent was initiated from the surface, the descent rate of the lift system was difficult to control. The initial few feet of descent from the surface were generally when the divers lost control of the lift bag. This is because the entrained air bubble (and hence buoyant force) undergoes the most rapid change in volume near the surface. Ideally, the descent rate could be maintained with proper setting of the control zipper (set for neutral buoyancy of the system) and an adequate system for adding air. The results of these tests show that setting the zipper for neutral buoyancy at the surface requires more skill and patience than setting it while on the bottom. This is because it is difficult to displace the bag at the surface (and hence estimate the net buoyancy of the system), since the diver is neutrally buoyant and does not have a solid reaction surface to work against. In addition, the air supply system used during these tests was not large enough to compensate for the rapid change of air volume near the surface. While the squirt valve is adequate for hovering and ascent control, it is not large enough to provide the flowrates required during descents from the surface. Divers commented that the valve is easy to use (since it can be throttled to provide fine adjustment), but is just too small for use near the surface.

4. The lift bags remained on the surface following an uncontrolled ascent. These tests were conducted on the small and medium sized lift bags using test loads of approximately the maximum and minimum rated capacity of the lift bags. In all cases, the lift bags remained on the surface.

5. The mechanism for attaching the dump valve to the lift bag does not provide a good leak-proof seal. The divers commented that the 200- to 550-pound bag leaked slightly between the flange and bag fabric. Although the leakage was considered minor, any leakage on a production model would be considered unacceptable.

Conclusions and Recommendations From ADM Testing

1. The control zipper provided good control of the lift bags during ascent and hover. Better control was obtained by reducing the flow restrictions through the zipper strength member.

2. The dump valve provided quick and easy venting of air. However, because the venting action is quiet, it was difficult for the divers to determine immediately how much air vented. The rubber diaphragm sealed well, but the nylon diaphragm leaked through the seam stitching.

3. The air supply system provides good control for hover and ascent modes, but does not provide the flowrates required for controlled descent from the surface. A larger valve for adding air to the lift bags should provide better control of the descent rate near the surface.

4. The lift bridle and slings should be redesigned to reduce weight and improve the load distribution.

Based on these results, the following recommendations were made for the Engineering Development Model Lift System:

1. Control zippers similar to those used on the 500- to 1,250-pound bag and the 1,000- to 3,000-pound bag should be incorporated into the 200- to 550-pound bag. Strength members (located behind the zippers) with less resistance to air flow should be incorporated on all lift bags.

2. The spring tension on the dump valves should be increased to provide better indication of valve opening. The valve used in the engineering development model should be fabricated of materials suitable for prolonged use in the ocean environment (for example, Delrin or an iodized aluminum). A nylon diaphragm with vulcanized seams should be purchased and evaluated along with the rubber diaphragm for reliability (EDM tests).

3. The dump valve attachment mechanism should be redesigned to provide easy access to the inside of the bag and a positive, leak-proof seal.

4. A lighter weight lifting bridle and attachment lines should be incorporated into the lift system.

ENGINEERING DEVELOPMENT MODEL (EDM)

During January through May 1987, the engineering development model (EDM) diver lift system was designed and fabricated under contract by Eastport International, Inc. The system incorporated the design modifications recommended from the ADM testing. In May through August 1987, laboratory and ocean tests of the EDM diver lift system were performed to verify reliability and performance thresholds as specified in the TEMP, and to identify any safety or human factors deficiencies. The development of the EDM system is documented in the following sections.

EDM System Description

Based on the TEMP (Appendix A) and the result of the ADM tests, the existing ADM system was modified and upgraded to an EDM system to provide improved performance and reliability. Modifications to the existing ADM system included:

1. A vertical zipper for venting air was incorporated into the 500- to 1,250-pound lift bag. The zipper was the same type used on the other lift bags (neoprene coated nylon and nickel-silver alloy) and was integrated into a section of the bag fabric (heavyweight neoprene coated nylon) by using the same vulcanizing technique previously used in joining the gores of the bag.

2. The holes for venting air through the strength members behind the control zippers were enlarged to reduce the air flow resistance. The venting holes on the ADM system consisted of 1/2-diameter holes with centers spaced vertically every 1-1/2 inch. The new venting holes, shown in Figure 3, are 2 inches long by 3/4 inch wide.

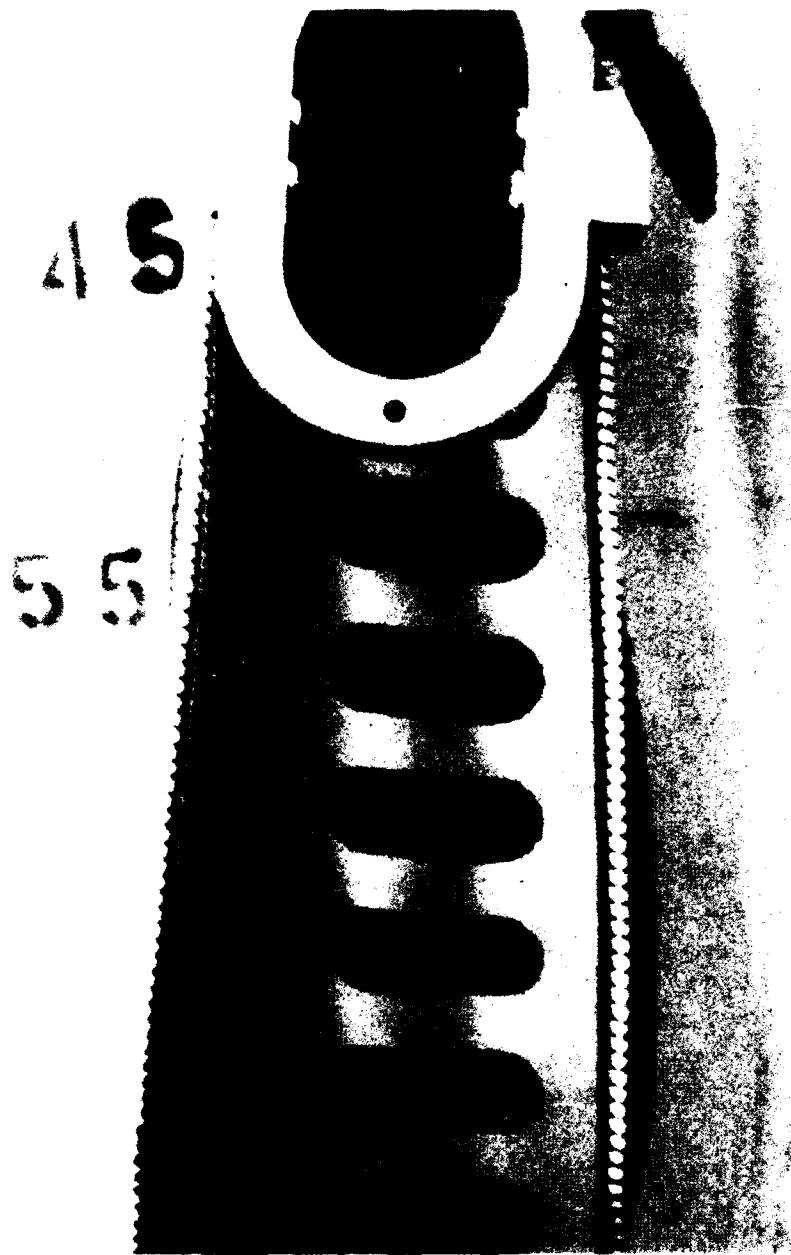

Figure 3. Venting holes in the control zipper strength member.

3. The dump valve was fabricated of materials compatible with use in seawater. Figure 4 shows the 6-inch diaphragm valve. All components of the valve consisted of Delrin plastic or stainless steel.

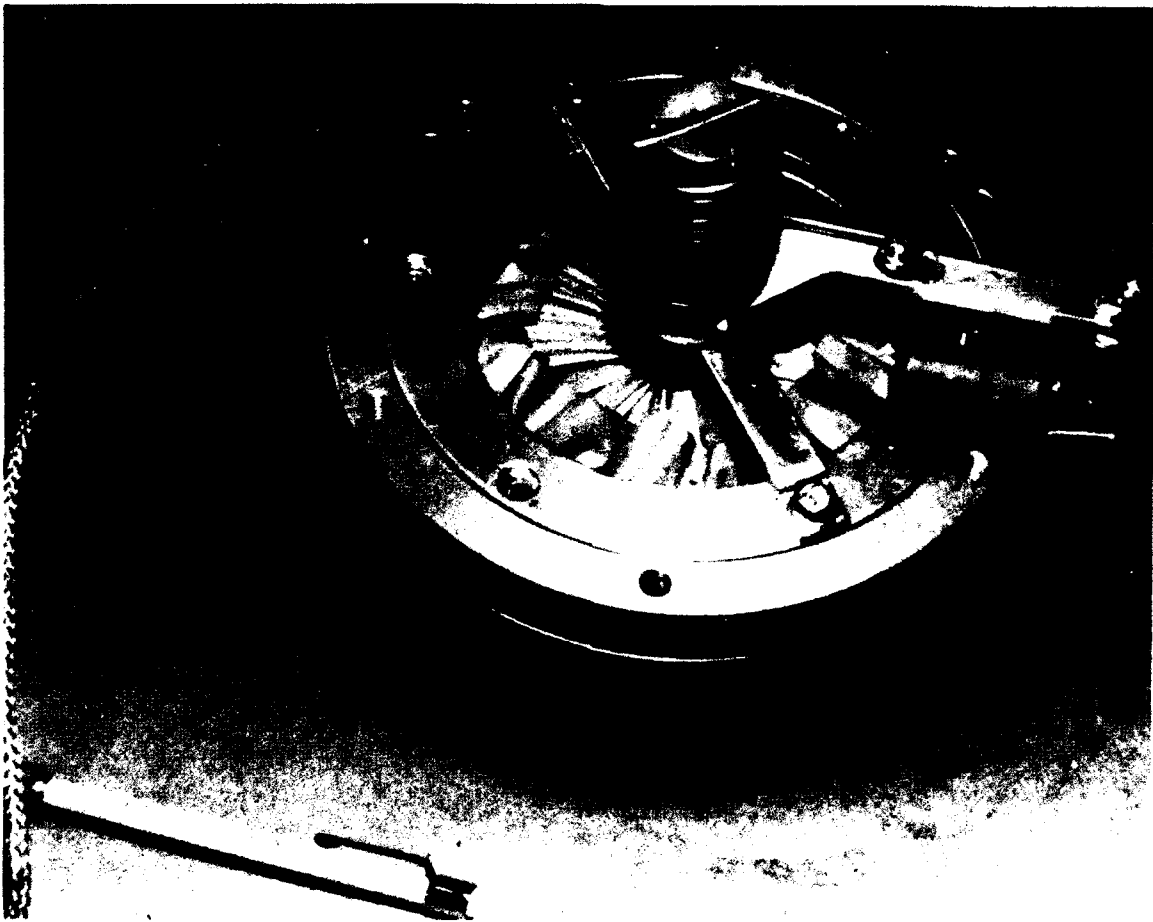

Figure 4. EDM 6-inch dump valve.

4. The air-fill valve was designed to deliver a larger volume of air while providing better control of the air flow. Figure 5 shows the new air-fill valve. Control of the air is provided by either squeezing a palm-activated trigger lever; or rotating a handle (with the trigger lever locked in the open position).

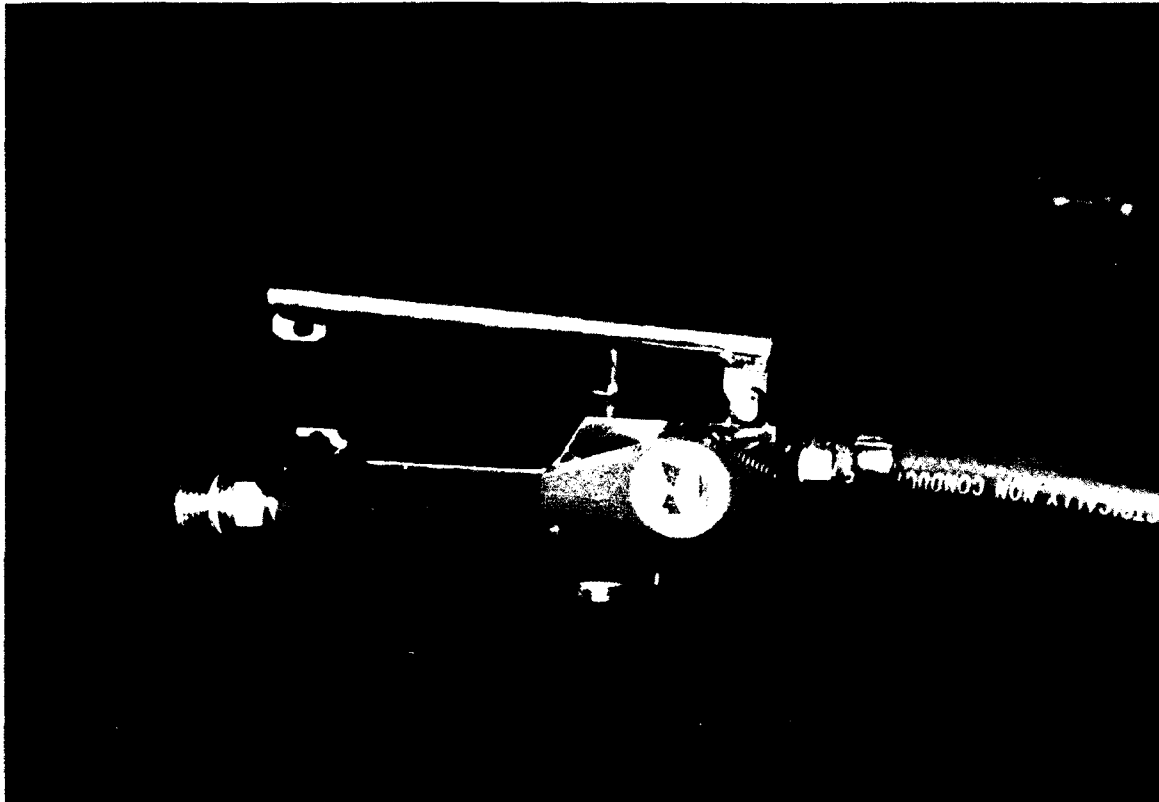

Figure 5. Hand-actuated air-fill valve.

5. The load lifting bridle was reduced in weight by decreasing the thickness of the ring at the base of the lift bag. In addition, to more evenly distribute the load to the slings, the number of slings for attaching a load was reduced from four to three.

Reliability Tests

Reliability is defined as the probability that the system will operate within design parameters without any component malfunction or failure during a mission. The operational cycle assumed in determining the reliability of the diver lift system is shown in Table 2.

Table 2
Diver Lift System Operational Cycle

Storage	Removal from Storage	Operating Time	Down Time (PM)	Back in Storage
1,440 hrs (2 months)	1 hr	8 hr	1 hr	1 hr
	Bag (2 cycles)	Control Zipper (10 cycles)		Bag (2 cycles)
		Dump Valve (10 cycles)		
		Air Fill Valve (15 cycles)		
Ready Time				

In order to determine the overall reliability of the system, each component must be operated enough cycles to determine its specific reliability. The number of failures or malfunctions occurring within the test cycle will determine the probability of successfully operating at various confidence levels. Table 3 shows the required number of test cycles for confidence levels of 60, 80, and 90 percent. For UCT use, a confidence level of 90 percent was chosen. Based on this, 80 test cycles (with 3 allowable failures) were required per mission cycle.

Table 3
Reliability Test Cycles

Confidence Level (%)	Allowable Failures	Test Cycles*
60	6	80
80	4	80
90	3	80

*Times the mean number of cycles the component is used in a mission cycle.

Based on the operational cycle shown above and the number of test cycles required for 90 percent confidence level, the component reliability for the zipper, control valve, fill valve, and bag material were evaluated in the laboratory and at sea. The results of the laboratory reliability tests on each component are shown in Table 4.

Table 4
Laboratory Component Reliability Tests

Component	Test Cycles	Failures	Confidence Level (%)	Reliability
Control Zipper	800	0	90	97 (at 10 cycles)
Dump Valve	800	0	90	97 (at 10 cycles)
Air Fill Valve	1,200	0	90	98 (at 15 cycles)
Fabric Seam	400	0	90	98 (at 5 cycles)

Zipper Reliability Test. The zipper reliability test was conducted to confirm the cyclic reliability of the zipper. Use of the zipper during a particular mission has been conservatively estimated at 10 times per mission cycle. Therefore, 800 test cycles must be made to assess reliability. A test cycle is defined as the zipper pull starting at one end, being pulled the entire length to the other end, and then pulled back the entire length to the starting point.

Zipper tests showed zero failures in 800 cycles demonstrating a reliability of 97 percent at the 90 percent confidence level for 10 operational cycles during an 8-hour mission.

Dump Valve Reliability Test. The dump valve reliability test was conducted to confirm the cyclic reliability of the 4-inch and the 6-inch iris diaphragm dump valves. The use of each valve was estimated at 10 times per mission cycle, indicating that 800 test cycles were required to assess reliability. A test cycle is the full opening and closing of the valve.

The test was performed using the test fixture shown in Figure 6. The valve was attached to one end of the fixture and compressed air was then added to the interior of the fixture to obtain a pressure difference of 5 psi. The lanyard on the valve was then pulled to open the valve, releasing the air. The lanyard was then released, thus completing one cycle.

There were zero failures during the tests, demonstrating a reliability of 97 percent at the 90 percent confidence level for 10 operational cycles during an 8-hour mission.

In addition to the reliability tests, the valves were also tested to determine the minimum spring force required to keep the valve diaphragm from leaking. Test results indicated that 3 pounds of spring force is adequate to keep both the large and small valve from leaking.

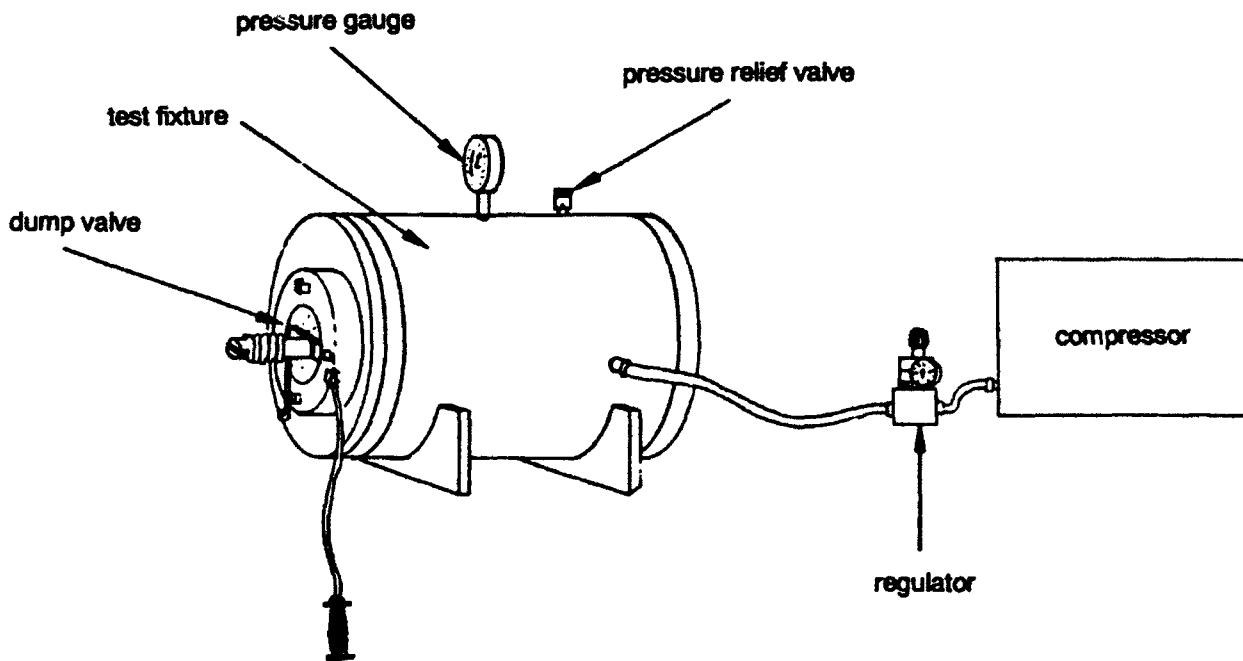
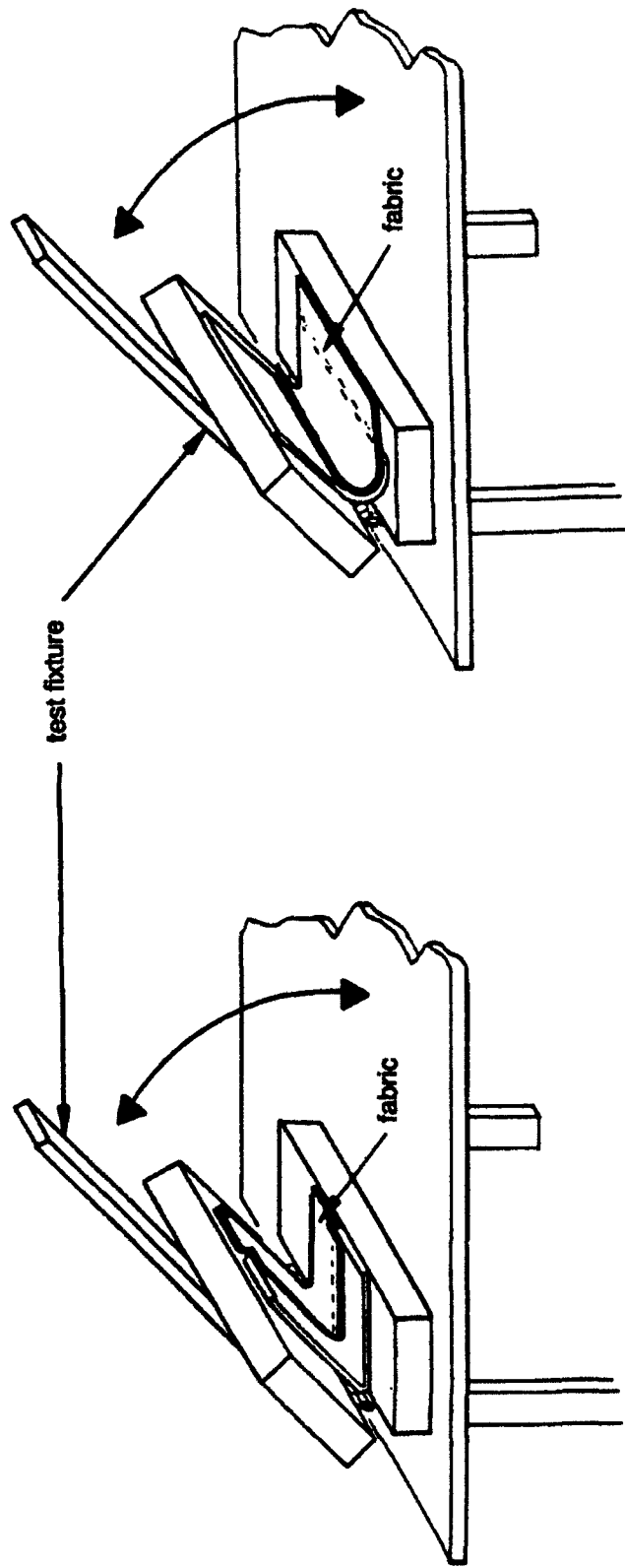

Figure 6. Dump valve test.

Material Seam Reliability Test. The material seam reliability test was conducted to provide information regarding the cyclic fatigue of the lift bag material in bending. Fabric seams were tested for perpendicular and parallel cyclic reliability. Seam testing was conducted using the fixture shown in Figure 7. A seam test sample was first securely fastened to the test fixture. The test fixture was then closed to compress the sample, simulating extreme storage conditions. This procedure was used for both seam orientations. A total of 400 compression cycles was completed for each seam orientation. There were no seam delaminations or punctures in either test sample. Some minor abrasion on both samples was observed where the material rubbed on a hinge of the test fixture. This abrasion was only superficial and is only a result of the test setups. This test resulted in zero failures, demonstrating a 98 percent reliability at 90 percent confidence level for 5 operational cycles per 8-hour mission.



Parallel flexing

Perpendicular flexing

Figure 7. Material seam reliability test.

Air-Fill Valve Reliability Test. The air-fill valve test was performed to determine the cyclic reliability of the valve. Use of the air-fill valve has been conservatively estimated at 15 times per mission cycle. One cycle is defined as the full opening and closing of the air-fill valve.

The test was performed by coupling the air-hose valve to laboratory shop air, submerging the valve, actuating the valve, and noting any leakage or difficulties in actuating the valve. The valve operated without incident until cycle 250 when the handle was released but the valve spindle delayed momentarily before closing. This was considered a malfunction, not a failure, since it does not adversely affect operation of the system. The valve did not have another malfunction until approximately cycle 450, where the same problem occurred for 10 consecutive cycles. Normal operation continued until approximately 550 cycles where the same sticking malfunction was experienced and continued through cycle 1,200, the end of the testing.

Other than the sticking malfunction described above, no mechanical failures occurred in 1,200 cycles, demonstrating a reliability of 98 percent at the 90 percent confidence level for 15 operational cycles during an 8-hour mission. The sticking malfunction indicates that preventative maintenance should be conducted every 75 operational cycles. Assuming 15 operational cycles per day and a 5-day week, the air-fill valve should be lubricated on a weekly basis. Due to the harsh environment in which the UCTs operate and the ease of this maintenance action, the operating instructions will stipulate that the valve be lubricated after each use.

At-Sea Reliability Tests. Additional test cycles and reliability data were generated during at-sea tests conducted offshore Anacapa Island (described in At-Sea Tests). With the data from these tests, an additional 30 mission cycles can be added to the reliability data base. Based on the operational cycle shown in Table 2 (and no component failures observed during the ocean tests), the reliability of the individual components is listed in Table 5.

Table 5
Individual Component Reliability

Item	Confidence Level (%)	Demonstrated Reliability (%)
Control Zipper	90	98
Dump Valve	90	98
Air-Fill Valve	90	98
Lift Bag Seam Material	90	98

Overall System Reliability. Based on the laboratory tests and the ocean tests, the overall system reliability at the 90 percent confidence level is 92.2 percent. Therefore, the diver lift system has exceeded all of the operational suitability thresholds specified in the TEMP.

Inverted Bag Test

The inverted bag test was conducted to assess the watertight integrity of the bag, and strength of the material. Each of the three lift bags was suspended in an inverted attitude from an A-frame support and filled with water to the rated load of the bag (see Figure 8). After the bag was filled it was inspected for leakage. The control zipper and dump valve were also actuated to verify operation. The test results are:

1. The small bag (200 to 550 pounds) had no leakage from the valve diaphragm, but did have very minor leakage from the mounting plate used for attaching the valve to the bag. This leakage resulted from the valve mounting plate being too thick and preventing the bag material from being adequately squeezed for a watertight seal. This problem was resolved by reducing the thickness of the valve mounting plate.

2. The medium bag (500 to 1,250 pounds) had a leak near the valve that was due to a small cut, and a mounting plate leak that resulted from the same problem as the small bag. The small cut was patched and the mounting plate was machined, thereby sealing the bag.

3. The large bag (1,000 to 3,000 pounds) had a leak only from a small hole in the bag material. This leak was fixed and no further leaks were seen.

These test results demonstrate that all three sizes of lift bags are capable of supporting their design loads. In addition, all control zippers and dump valves are capable of leak-proof operation.

At-Sea Tests

The objective of the at-sea tests was to establish the operational performance of the lift system for comparison to the TEMP thresholds. These tests, conducted at Anacapa Island with diver support provided by the NCEL dive locker, included ascent and descent tests, hover tests, and porpoise (uncontrolled ascent) tests.

Ascent and Descent Tests. To evaluate the vertical control of the lift system, ascent and descent tests were performed on each of the three lift bags. These tests were conducted with the bags loaded within their rated capacities.

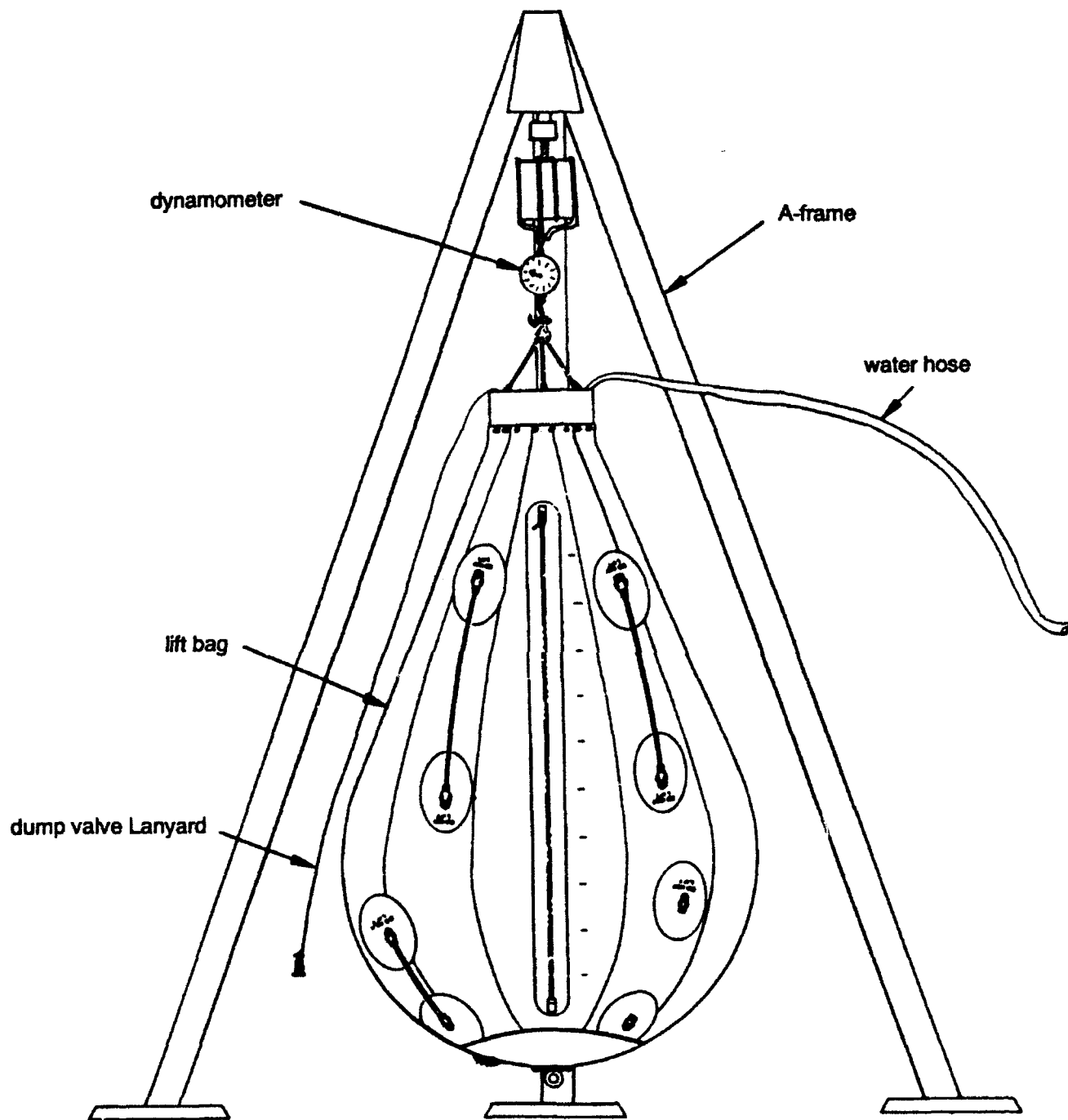

Figure 8. Inverted bag test.

The first dive team began the testing with the medium lift bag loaded with concrete clumps weighing approximately 1,000 pounds. The water was about 47 feet deep. It was apparent at the start of this test that the divers could not get the lift bag neutrally buoyant. When inflated with an attached load, the tension in the bag material prevented the bag from opening below the zipper slider. This resulted in restricting the venting of excess air from the bag. A controlled ascent was not possible even though several attempts were made.

The second dive team was given a wire-rope thimble to place just below the zipper slider. The thimble was expected to keep the fabric below the slider open and allow excess air to vent out of the bag. After adjusting the zipper and thimble to obtain neutral buoyancy, the divers attempted controlled ascent and descent tests. The divers reported that they had good control of the lift bag with the zipper and thimble set to obtain a slightly negative buoyancy of the bag and load. With the zipper set in this position, the buoyancy of the system can be made slightly positive by adding air into the bag (from the fill valve) faster than the thimble can vent it. Obtaining this position was difficult, however, since it required a process of iteration (adding air, assessing net buoyancy, adjusting the zipper, and securing the thimble). Once this position was found, the dive team completed five controlled ascent and descent cycles with the 1,000-pound weight. Each successive ascent and descent provided the divers with increased control as they learned the effects of adding air, and the bag reaction time associated with it.

The third dive team was also able to make controlled ascents with the 500- to 1,250-pound lift bag by positioning the thimble along the zipper to obtain a slightly negative buoyancy.

Each dive team commented on the difficulty in regulating the volume of air released from the dump valve. This was attributed to: (1) the excessive pull length required to open the valve; and (2) the operator's inability to sense when the valve was opened and closed. To improve the valve action, the stroke required to open the valve was reduced to about one-half of its original pull length. This was done by progressively decreasing the torsion spring pre-load, which limited how tightly the diaphragm would close. In addition, a double-braided Dacron line was also used in place of the nylon lanyard to reduce the line stretch when tensioned. Divers reported that these changes improved the valve's operation.

Because the iris dump valve is relatively quiet in operation, it is difficult for the diver to determine how much air is being dumped, unless he is in position to view the valve. When the diver was not in position to watch the dumping action, the tendency in operating the dump valve was to open the valve and then wait for the bag reaction before closing the valve. This usually resulted in uncontrolled descents. Training would provide improved buoyancy control with the dump valve.

Discussions with the divers indicated that the control mechanism preferred was the control zipper. The dump valve was used primarily to dump air at the surface and bottom, and as an emergency air release.

Additional testing was done with the large (1,000- to 3,000-pound) lift bag in 62 feet of water with a 1,500-pound load. As before, a thimble was used to aid in venting the expanding air in the bag during ascents. The first day's testing provided valuable experience for the divers, and their proficiency with the lift bags increased with each use. Controlled ascents and descents of approximately 1 ft/sec were made by each dive team.

Ascent and Descent Test with Modified Zipper. A device was designed to incorporate an expansion ring with the zipper. The expansion ring was positioned just below the zipper slider and was attached to the zipper itself. As the slider was raised or lowered, the expansion ring would follow, allowing the excess air to escape during ascents. This device was tested using the small and medium lift bags in 60 feet of water off Anacapa Island.

The small (200- to 550-pound) lift bag was put in the water and attached to a 450-pound load. The divers were able to set the zipper quickly and move the loaded bag wherever they wanted. Ascents and descents were performed as before but this time the divers had more control of the buoyant force. Small buoyancy adjustments were now possible by sliding the zipper slider and expansion ring assembly together as a unit. No problems were encountered in the operation with this new modification.

A transducer was attached to the medium (500- to 1,250-pound) lift bag to record changes of depth with time. A 1,000-pound load was put into the water and the bag and divers deployed. The divers reported that they had no problem in setting the buoyancy of the bag. After adjusting the zipper (for slightly negative buoyancy), the operator of the air inlet valve positioned himself about 15 feet away from the bag. From this position, the operator reported that he could "drive" the lift bag up and down under complete control. Figure 9 shows controlled ascents of 22 ft/min and 53 ft/min, demonstrating that the TEMP thresholds can be met when the divers are trained to use the system.

Hover Tests and Positioning Control. To evaluate the hover and positioning control of the lift bags, tests were conducted on the seafloor (about 60 feet deep) and in the mid-water column (see Figure 10). The tests conducted on the seafloor consisted of inflating the lift bags on the seafloor, obtaining neutral buoyancy (for 3 to 5 minutes), moving the bag over about 5 feet, and lowering the bag gently back down on the seafloor. The results of this test indicate that hovering within ± 0.5 feet was accomplished easily.

Positioning the lift bags was easily accomplished by setting a slightly negative buoyancy in the bag (10 to 20 pounds). With the bag slightly negative, the diver simply picked up the bag and moved it around as desired.

While performing the ascent and descent portion of the ocean tests, the divers were instructed to attempt to stop in mid-water and hover, keeping the bag under control. They were able to hover with the medium and large lift bags for approximately 10 seconds before continuing the ascent and descent. Figure 4 shows these data. Since this threshold assumes that the diver has visual or tactile reference (as to relative positions or speeds) and that water motions (surge, current, etc.) are negligible, no attempt was made to remain hovering beyond 10 seconds because there was a strong current running through the test site preventing the use of a vertical reference line during the tests.

In addition, without a point of reference in the mid-water column, it is difficult for the divers to determine if the bag is rising, descending, or hovering. The diver's attention was required to keep the lift bags under control during all of the hover attempts due to currents at the test site.

After the zipper expansion ring modification had been made, subsequent testing showed improved diver control of the lift bags during all phases of operation. The modification made operating the zippers easier, even with a load on the bag. An accurate zipper setting enabled the dive teams to move the bags through the water column under complete control, and to stop and hover as needed or desired. These data indicate that the TEMP threshold for hover and positioning control can be met.



Figure 9. Controlled ascents at 22 ft/min and 53 ft/min.

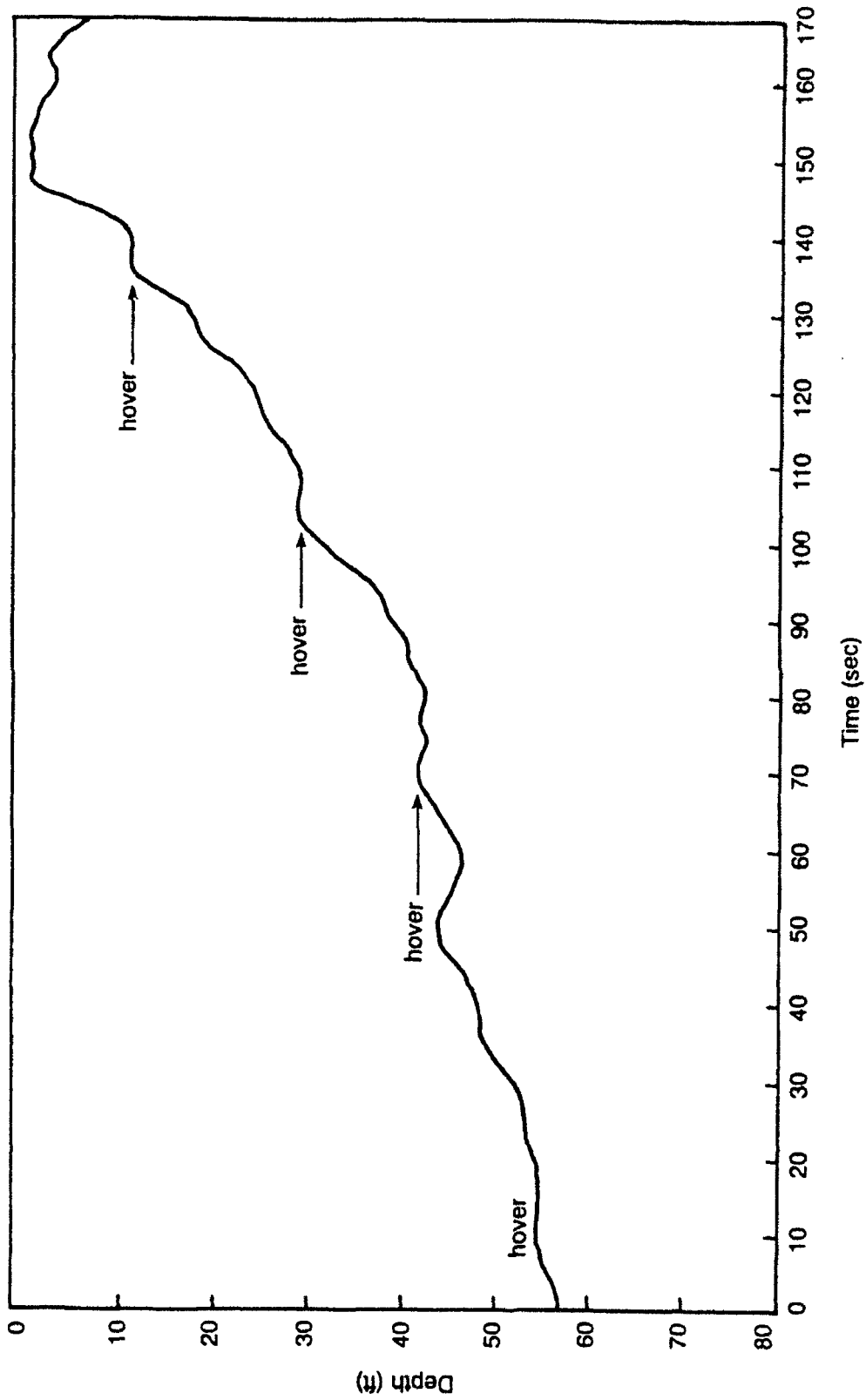

Figure 10. Hover test results with medium and large lift bags.

Uncontrolled Ascent. To evaluate the stability of the lift bag after an uncontrolled ascent, each lift bag was inflated at 60 feet of water and released to the surface. These tests were conducted with the bags attached to a load and the control zipper set for maximum buoyancy.

The results of these tests showed that these bags will remain on the surface after an uncontrolled ascent. Typically, after reaching the surface, these bags broached the surface and then settled back into the water in a floating position. While on the surface, all of the bags remained vertical and upright. Provided that there are no leaks in the dump valve or the bag fabric, these bags will remain on the surface in excess of the TEMP threshold for On-Surface Stability (5 minutes unattended and 1 hour with diver attendance). As an example, Figure 9 shows changes of depth with time of the medium sized lift bag with a 500-pound load.

Although these lift bags demonstrated their stability on the surface, uncontrolled descents are possible if the zipper is set for near neutral buoyancy and the system is being used by an inexperienced operator. To avoid this possibility, the operating instructions should stipulate that the divers close the zipper when the lift bag is on or approaching the surface.

Results of EDM Tests

Test results show that the EDM Diver Lift System met or exceeded the requirements stated in the TEMP for operating characteristics. Table 6 summarizes the results of the EDM tests on the diver lift system.

USER TESTS

User tests of the EDM Diver Lift System were conducted by divers from the NCEL dive locker on 22 March 1988. These tests were performed to verify reliability and performance thresholds (as specified in the TEMP) and to identify any safety or human factors deficiencies. Originally scheduled with UCT-2, and later scheduled with the Naval Construction Training Center (NCTC) Delta Company, these tests were performed by the NCEL dive locker due to UCT and NCTC scheduling conflicts. Although the user tests were performed with NCEL personnel, two of the evaluating divers (including a Master Chief) had been recently stationed with the Underwater Construction Teams.

The results of the User Test are documented in Reference 5. These tests concluded that the Diver Lift System meets the requirements of the Underwater Construction Teams. The system was reported to be quite durable and have a great degree of control not previously seen in a lift bag system. It was also reported that training was absolutely necessary for safe, effective operation of the system.

Table 6
Summary of EDM Test Results

Characteristic	Threshold	Results
Load Range In Water Dry Weight	50-3,000 lb 60-5,000 lb	50-3,000 lb 50-5,000 lb
Operating Depth Range	0-190 feet	0-190 feet
Operational Environment Sea State Swell	SS 0-3 Up to 4 ft with 8 sec or longer period	Demonstrated SS 0-1. SS 2-3 not available during test.
On Surface Stability	5 min unattended 1 hour attended	> 5 min > 1 hour
Vertical Transport Ascent Rate Descent Rate (deeper than 30 feet)	0.3-0.9 ft/sec 0.3-0.9 ft/sec	0.3-0.9 ft/sec 0.3-0.9 ft/sec
Hover Control With Attention	±0.5 ft for 5 min ±5 ft for 30 min	±0.5 ft for 5 min with seafloor reference ±5 ft for 30 min with seafloor reference
Position Control	0.1 ft/sec for distances of 2 ft	0.1 ft/sec for distances of 2 ft on seafloor
Availability	95% when pulled from storage	96% (based on 80 hrs MCBF and 3 hrs to repair)
MTBF	10 deployments or uses	> 10 uses
MTTR	< 3 manhours effort < 24 hours on the beach for 80% failures	< 3 manhours effort < 24 hours on the beach for user repair items*

*User repair items include:

1. Patch kit (for small tears or holes in fabric)
2. Dump valve repair kit
3. Convenient handle
4. Zipper repairs will be performed at depot level

Recommendations from the User Test include:

1. The system should be included in the NCTC school as part of their training.
2. The buoyancy of the air-fill wand should be slightly negative. In the event that the diver loses the air-fill wand, this might prevent an aborted dive.
3. The system should be approved for production and distributed to the Underwater Construction Teams.

CONCLUSIONS

1. A simple, controllable, underwater lift system for diver use has been developed. This system consists of three different open-bottom lift bags in the following lift ranges: 200 to 550, 500 to 1,250, and 1,000 to 3,000 pounds. Diver control of the buoyant force is obtained by adjusting the venting zipper (on the lift bag) and an air wand (attached to a surface supplied air hose).

2. The development of the new diver lift system included the design, fabrication, and testing of both an Advanced Development Model (ADM) system and an Engineering Development Model (EDM) system.

3. Based on the EDM and User Test results, the Diver Lift System provides an improved underwater lifting capability for UCT use. TEMP performance and reliability thresholds were demonstrated during EDM testing. The utility of the system for supporting UCT operations was verified during User Tests.

RECOMMENDATIONS

Based on the results of the development effort, it is recommended that:

1. The Diver Lift System proceed into production.
2. Include the Diver Lift System in the NCTC school as part of their training curriculum.
3. NCEL monitor performance of the first production model Diver Lift System during a UCT operation to ensure a smooth transition into Fleet use.
4. Update the User Data Package. Update with as-built drawings after every production run.

REFERENCES

1. Naval Civil Engineering Laboratory. TM 43-81-03: Construction diver lift systems - A zero milestone report, by LT D.A. Vidal, CEC, USN, Port Hueneme, CA, Jan 1981.
2. _____. Memorandum to files on the evaluation of construction diver lift systems, by Hugh Thomson (NCEL), Greg Bryant (SBCC), and Fred Barrett (Human Engineering Consultants), Port Hueneme, CA, Mar 1983.
3. _____. Memo for the Record Ser 443: Development options for the UCT Diver Lift System. Port Hueneme, CA, 21 Mar 1983.
4. Naval Facilities Engineering Command. Memo for the Record Ser 0320/1425: Requirements for UCT Diver Lift System. Alexandria, VA, 7 Sep 1984.
5. Naval Civil Engineering Laboratory ltr 3900, Ser L40PM/0961 of 21 Jun 1988. Subj: User test reports on the diver lift system and the buried pipe and chain locator.

Appendix

TEST AND EVALUATION MASTER PLAN

I. COMPONENT DESCRIPTION

DIVER LIFT SYSTEMS MISSION AND REQUIRED OPERATIONAL CHARACTERISTICS

WBS 2.250

MISSION: To provide a controllable, underwater lift capability for divers.

<u>Characteristics</u>	<u>Threshold</u>
A. Operational Requirements	
<u>Load Range</u>	
in water	50 - 3,000 lb
dry weight	60 - 5,000 lb
<u>Operating Depth Range</u>	0 - 190 ft
<u>Operational Environment</u>	
sea state	0 - 3
swell	Up to 4 ft with an 8 sec or longer period
<u>On-Surface Stability</u>	The system is stable on the surface (whether it got there by being deployed over the side of a craft with load and then inflated/ballasted, or by controlled ascent from the seafloor, or by uncontrolled ascent) for a minimum of 5 min unattended and for 1 hr with diver attendance.
B. Performance Requirements - For the following three criteria it is assumed that the diver will have visual or tactile reference as to relative positions or vertical speeds. Furthermore, it is assumed that the diver is trained and experienced with the system's operation, and that water motions (surge, current, etc.) are negligible. Diver operation is primarily one-handed with occasional two-handed operation.	

Characteristics

Threshold

Vertical Transport

In an elevator mode the system should be capable of attaining specific diver selected and adjusted ascent-descent rates between 0.3 and 0.9 ft/sec within ± 0.1 ft/sec.

Hover Control

At water depths greater than 20 ft, the system(s) will be capable of hovering at depths to within the following: (a) ± 1 ft for 1 min without diver attention; (b) ± 3 ft for 30 min with diver attention; and (c) ± 0.5 ft for 5 min with diver attention.

Positioning Control

The system can be controlled in ascent or descent to rates of 0.1 ft/sec ± 0.05 ft/sec for vertical distances of 2 ft for gentle positioning, landing, assembling, etc.

C. Operational Suitability

Availability

The system shall work 95% of the time when pulled from active storage, on arrival on site in the provided shipping container(s) and upon demand at the boat/platform (taking into consideration the usual handling on the beach, waterfront, and small boat environment).

Mean Cycles Between Failure (MTBF)

> 10 deployments or uses

Mean Time to Repair (MTTR)

MTTR should be less than 3 man-hr effort and 24 hr elapsed time on the beach BEQ environment for at least 80% of all failures incurred.

Redundant Supply of Two or More Units is Acceptable

Reliability of Two Units

> 99%

Preventive Maintenance Times

Daily

< 1 hr

End of project

< 1 hr

Annual

< 3 hr

DISTRIBUTION LIST

AF / ROBERTS, PARTICK AFB, FL
ARMY CEWES / (TW RICHARDSON), VICKSBURG, MS
ARMY EWES / PERRY, VICKSBURG, MS; WESCD-P (MELBY), VICKSBURG, MS;
WESCV-Z (WHALIN), VICKSBURG, MS
BUREAU OF RECLAMATION / D-1512 (GS DEPUY), DENVER, CO; SMOAK, DENVER, CO
CAL STATE UNIV / C.V. CHELAPATI, LONG BEACH, CA
CHESNAVFACENCOM / CODE FPO-1C, WASHINGTON, DC; YACHNIS, WASHINGTON, DC
CITY OF MONTEREY / CONST MGR (REICHMUTH), MONTEREY, CA
COLORADO SCHOOL OF MINES / DEPT OF ENGRG (CHUNG), GOLDEN, CO
COMNAVACT / PWO, LONDON, UK, FPO AE
COMNAVAIRSYSCOM / CODE 422, WASHINGTON, DC
COMNAVSURF / CODE N42A, NORFOLK, VA; LANT, CO, NORFOLK, VA; PAC, CODE
N-4, SAN DIEGO, CA
COMSUBDEVGRU ONE / OPS OFFR, SAN DIEGO, CA
COMSUBPAC / CODE 541, SCE, PEARL HARBOR, HI
CORNELL UNIV / CIVIL & ENVIRON ENGRG, ITHACA, NY
DCD, USAES / ATSE-CDM-S (SFC FARBER), FT LEONARD WOOD, MO
DEPT OF BOATING / ARMSTRONG, SACRAMENTO, CA
DFSC-F / ALEXANDRIA, VA
DTRC / CODE 2724, BLOOMQUIST, ANNAPOLIS, MD
EODMU / THREE, POINT MUGU, CA
EXXON PRODUCTION RSCH CO / OFFSHORE OP DIV, HOUSTON, TX
GEI CONSULTANTS, INC. / T.C. DUNN, WINCHESTER, MA
IOWA STATE UNIV / CE DEPT, AMES, IA
LONG BEACH PORT / ENGRG DIR (ALLEN), LONG BEACH, CA; ENGRG DIR (LUZZI),
LONG BEACH, CA
MBARI / SHANE, MOSS LANDING, CA
MCAS / 16, MAG, TUSTIN, CA; PWO, KANEOHE BAY, HI
MCRD / PWO, SAN DIEGO, CA
MICHIGAN TECH UNIV / CO DEPT (HAAS), HOUGHTON, MI
NAVCOASTSYSCEN / PWO (CODE 740), PANAMA CITY, FL
NAVDIVESALVTRACEN / CO, PANAMA CITY, FL
NAVFACENCOM / CODE 04A3, ALEXANDRIA, VA; CODE 04A3C, HUBLER,
ALEXANDRIA, VA; CODE 07M (BENDER), ALEXANDRIA, VA
NAVOCEANO / CODE 6200 (M PAIGE), NSTL, MS
NAVSHIPYD / CARR INLET ACOUSTIC RANGE, BREMERTON, WA
NAVSPNSTA / PWO, CHARLESTON, SC
NAVSTA / ENGR DIV, PWD, FPO AA; PWO, ROTA, SPAIN, FPO AE
NAVSTA PUGET SOUND / CODE 922, EVERETT, WA
NAVSUPACT / CODE 430, NEW ORLEANS, LA
NAVSUPFAC / CONTRACT ASSISTANT, FPO AP
NCTC / PLATT, PORT HUENEME, CA
NOAA / JOSEPH VADUS, ROCKVILLE, MD
NORDA / CODE 500, NSTL, MS
NRAD / CODE 944 (H.C. WHEELER), SAN DIEGO, CA; CODE 944 (ROBERT WERNLI),
SAN DIEGO, CA
NUSC / CODE 0031 DIVING OFFR, NEWPORT, RI

NUSC DET / NEWPORT, RI; CODE 2143 (VARLEY), NEW LONDON, CT; CODE TA131,
NEW LONDON, CT; DOC LIB, NEW LONDON, CT
OCNR / CODE 1121 (EA SILVA), ARLINGTON, VA
OREGON STATE UNIV / CE DEPT (BELL), CORVALLIS, OR; OCEANOGRAPHY SCOL,
CORVALLIS, OR
PACNAVFACENCOM / CODE 102, PEARL HARBOR, HI
PMTG / CODE P4234 (G. NUSSEAR), POINT MUGU, CA
PURDUE UNIV / CE SCOL (ALTSCHAEFFL), WEST LAFAYETTE, IN; CE SCOL
(LEONARDS), WEST LAFAYETTE, IN; ENGRG LIB, WEST LAFAYETTE, IN
PWC / CODE 400A.3, FPO AP; CODE 421 (KAYA), PEARL HARBOR, HI; CODE 421
(QUIN), SAN DIEGO, CA
SAN DIEGO STATE UNIV / CE DEPT (NOORANY), SAN DIEGO, CA
SEAL TEAM / 6, NORFOLK, VA
SEATTLE UNIV / CE DEPT (SCHWAEGLER), SEATTLE, WA
TEXAS A&M UNIV / CE DEPT (HERBICH), COLLEGE STATION, TX; OCEAN ENGR
PROJ, COLLEGE STATION, TX
UNIV OF CALIFORNIA / CE DEPT (MITCHELL), BERKELEY, CA; NAVAL ARCHT DEPT,
BERKELEY, CA
UNIV OF HAWAII / LOOK LAB, OCEAN ENGRG, HONOLULU, HI; MANOA, LIB,
HONOLULU, HI
UNIV OF MICHIGAN / CE DEPT (RICHART), ANN ARBOR, MI
UNIV OF NEW HAMPSHIRE / LAVOIE, DURHAM, NH
UNIV OF RHODE ISLAND / PELL MARINE SCI LIB, NARRAGANSETT, RI
UNIV OF TEXAS / CONSTRUCTION INDUSTRY INST, AUSTIN, TX
UNIV OF WISCONSIN / GREAT LAKES STUDIES CEN, MILWAUKEE, WI
USA EWES / WESCR-P (HALES), VICKSBURG, MS
USACOE / CESP-D-CO-EQ, SAN FRANCISCO, CA
USAE / CEWES-IM-MI-R, VICKSBURG, MS
USDA / FOR SVC, EQUIP DEV CEN, SAN DIMAS, CA
USN / CAPT COLIN M JONES, HONOLULU, HI
USNA / OCEAN ENGRG DEPT, ANNAPOLIS, MD
WESTNAVFACENCOM / CODE 407, SAN BRUNO, CA; ROICC, SILVERDALE, WA
WOODS HOLE OCEANOGRAPHIC INST / DOC LIB, WOODS HOLE, MA

DISTRIBUTION QUESTIONNAIRE

The Naval Civil Engineering Laboratory is revising its primary distribution lists.

SUBJECT CATEGORIES

1 SHORE FACILITIES

- 1A Construction methods and materials (including corrosion control, coatings)
- 1B Waterfront structures (maintenance/deterioration control)
- 1C Utilities (including power conditioning)
- 1D Explosives safety
- 1E Aviation Engineering Test Facilities
- 1F Fire prevention and control
- 1G Antenna technology
- 1H Structural analysis and design (Including numerical and computer techniques)
- 1J Protective construction (including hardened shelters, shock and vibration studies)
- 1K Soil/rock mechanics
- 1L Airfields and pavements
- 1M Physical security

2 ADVANCED BASE AND AMPHIBIOUS FACILITIES

- 2A Base facilities (Including shelters, power generation, water supplies)
- 2B Expedient roads/airfields/bridges
- 2C Over-the-beach operations (including breakwaters, wave forces)
- 2D POL storage, transfer, and distribution
- 2E Polar engineering

3 ENERGY/POWER GENERATION

- 3A Thermal conservation (thermal engineering of buildings, HVAC systems, energy loss measurement, power generation)
- 3B Controls and electrical conservation (electrical systems, energy monitoring and control systems)
- 3C Fuel flexibility (liquid fuels, coal utilization, energy from solid waste)

3D Alternate energy source (geothermal power, photovoltaic power systems, solar systems, wind systems, energy storage systems)

3E Site data and systems integration (energy resource data, integrating energy systems)

3F EMCS design

4 ENVIRONMENTAL PROTECTION

- 4A Solid waste management
- 4B Hazardous/toxic materials management
- 4C Wastewater management and sanitary engineering
- 4D Oil pollution removal and recovery
- 4E Air pollution
- 4F Noise abatement

5 OCEAN ENGINEERING

- 5A Seafloor soils and foundations
- 5B Seafloor construction systems and operations (including diver and manipulator tools)
- 5C Undersea structures and materials
- 5D Anchors and moorings
- 5E Undersea power systems, electromechanical cables, and connectors
- 5F Pressure vessel facilities
- 5G Physical environment (including site surveying)
- 5H Ocean-based concrete structures
- 5J Hyperbaric chambers
- 5K Undersea cable dynamics

ARMY FEAP

- BDG Shore Facilities
- NRG Energy
- ENV Environmental/Natural Responses
- MGT Management
- PRR Pavements/Railroads

TYPES OF DOCUMENTS

D - Techdata Sheets; R - Technical Reports and Technical Notes; G - NCEL Guides and Abstracts; I - Index to TDS; U - User Guides; None - remove my name

Old Address:

Telephone No.: _____

New Address:

Telephone No.: _____

INSTRUCTIONS

The Naval Civil Engineering Laboratory has revised its primary distribution lists. To help us verify our records and update our data base, please do the following:

- Add - circle number on list
- Remove my name from all your lists - check box on list.
- Change my address - line out incorrect line and write in correction **(DO NOT REMOVE LABEL).**
- Number of copies should be entered after the title of the subject categories you select.
- Are we sending you the correct type of document? If not, circle the type(s) of document(s) you want to receive listed on the back of this card.

Fold on line, staple, and drop in mail.

DEPARTMENT OF THE NAVY
Naval Civil Engineering Laboratory
560 Laboratory Drive
Port Hueneme CA 93043-4328

Official Business
Penalty for Private Use, \$300

BUSINESS REPLY CARD

FIRST CLASS PERMIT NO. 12503 WASH D.C.

POSTAGE WILL BE PAID BY ADDRESSEE



NO POSTAGE
NECESSARY
IF MAILED
IN THE
UNITED STATES



**COMMANDING OFFICER
CODE L34
560 LABORATORY DRIVE
NAVAL CIVIL ENGINEERING LABORATORY
PORT HUENEME CA 93043-4328**

NCEL DOCUMENT EVALUATION

You are number one with us; how do we rate with you?

We at NCEL want to provide you our customer the best possible reports but we need your help. Therefore, I ask you to please take the time from your busy schedule to fill out this questionnaire. Your response will assist us in providing the best reports possible for our users. I wish to thank you in advance for your assistance. I assure you that the information you provide will help us to be more responsive to your future needs.

R. N. Storer

R. N. STORER, Ph.D., P.E.
Technical Director

DOCUMENT NO. _____ TITLE OF DOCUMENT: _____

Date: _____ Respondent Organization: _____

Name: _____ Activity Code: _____

Phone: _____ Grade/Rank: _____

Category (please check):

Sponsor _____ User _____ Proponent _____ Other (Specify) _____

Please answer on your behalf only; not on your organization's. Please check (use an X) only the block that most closely describes your attitude or feeling toward that statement:

SA Strongly Agree A Agree O Neutral D Disagree SD Strongly Disagree

	SA	A	O	D	SD	
1. The technical quality of the report is comparable to most of my other sources of technical information.	()	()	()	()	()	
2. The report will make significant improvements in the cost and or performance of my operation.	()	()	()	()	()	
3. The report acknowledges related work accomplished by others.	()	()	()	()	()	
4. The report is well formatted.	()	()	()	()	()	
5. The report is clearly written.	()	()	()	()	()	
6. The conclusions and recommendations are clear and directly supported by the contents of the report.	()	()	()	()	()	
7. The graphics, tables, and photographs are well done.	()	()	()	()	()	

Do you wish to continue getting NCEL reports? YES NO

Please add any comments (e.g., in what ways can we improve the quality of our reports?) on the back of this form.

Comments:

Fold on line, staple, and drop in mail.

DEPARTMENT OF THE NAVY
Naval Civil Engineering Laboratory
560 Laboratory Drive
Port Hueneme CA 93043-4328

Official Business
Penalty for Private Use, \$300



BUSINESS REPLY CARD
FIRST CLASS PERMIT NO. 12503 WASH D.C.

POSTAGE WILL BE PAID BY ADDRESSEE

NO POSTAGE
NECESSARY
IF MAILED
IN THE
UNITED STATES



COMMANDING OFFICER
CODE L03
560 LABORATORY DRIVE
NAVAL CIVIL ENGINEERING LABORATORY
PORT HUENEME CA 93043-4328