

**BEST
AVAILABLE COPY**

JUN 4 1993

AD-A265 899

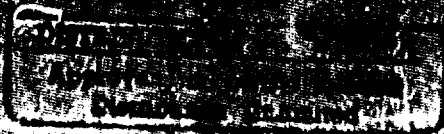

93

92

93-12480



DISCLAIMER NOTICE

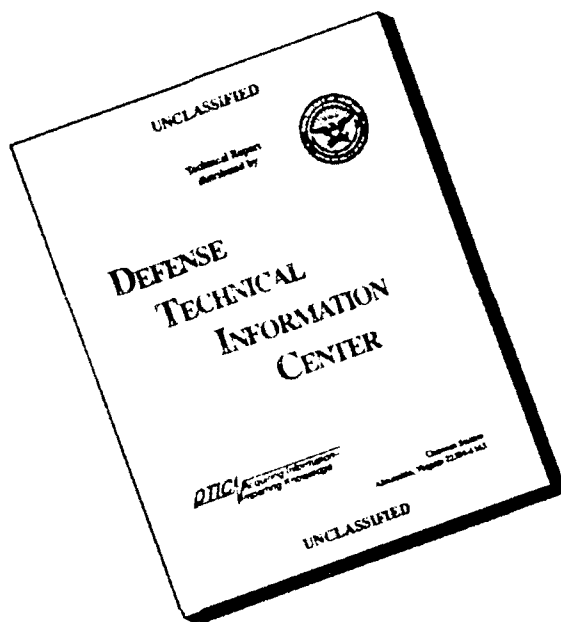

THIS DOCUMENT IS BEST QUALITY AVAILABLE. THE COPY FURNISHED TO DTIC CONTAINED A SIGNIFICANT NUMBER OF PAGES WHICH DO NOT REPRODUCE LEGIBLY.

**MUNICIPAL WASTE INCINERATOR
PUBLIC WORKS CENTER, YOKOSUKA JAPAN
EVALUATION AND RECOMMENDATIONS**

by

Wade B. Wilhelm
LT, CEC, USN

Department of Civil Engineering
Environmental Engineering and Science Program
University of Illinois at Urbana-Champaign

NTIS US AND BY UNRESTRICTED 5

April 1993

Accession For	
NTIS CRA&I	<input checked="" type="checkbox"/>
DTIC TAB	<input type="checkbox"/>
Unannounced	<input type="checkbox"/>
Justification	
By <i>Rec Form 50</i>	
Distribution /	
Availability Codes	
Dist	Avail and/or Special
<i>A-1</i>	

ABSTRACT

A study was done on the Municipal Waste Incinerator (MWI) located at the Public Works Center (PWC) Yokosuka, Japan. The facility consists of two incinerators with combustion capabilities of 3.54 ton (3.22 metric tons) per hour, each equipped with a quencher and a venturi tube where $\text{Ca}(\text{OH})_2$ and Tesisorb are injected to remove HCl and SO_2 from the gas stream, and a fabric filter to remove particulate matter. HCl, NO_x , and SO_2 emissions are continually monitored. Supporting facilities include waste segregation facilities, cardboard, aluminum, and plastic compacting equipment, and a wood shredder.

The facility currently meets both Japanese and U.S. air emission standards. This study investigated the feasibility of burning additional plastic and wood in the incinerator, methods of improving operations or decreasing costs, and evaluates the overall waste management program at the Yokosuka Base.

Additional wood and plastic may be burned in the incinerator, but it will make controlling the temperatures within the incinerator more difficult, thus this proposal is not popular with the operators. The $\text{Ca}(\text{OH})_2$ and Tesisorb injection rates were decreased during the site visit to prior to November 1991 levels. Additional savings, \$76,000 to \$100,000 per year, are proposed by eliminating Tesisorb injection completely, increasing the $\text{Ca}(\text{OH})_2$ injection rates, and changing the control scheme so that the $\text{Ca}(\text{OH})_2$ injection rate is not controlled by the gas temperature, but by the emission levels of SO_2 and HCl.

Regarding overall waste management it is recommended that off-base residents be taught how to dispose of their waste off base and encouraged to do so. The amounts of waste handled at the facility may be reduced by increased emphasis on recycling (especially paper) and through composting.

Table of Contents

	Page
I. Introduction	1
A. General Layout of the Municipal Waste Incinerator and Support Facilities	2
B. Operations and Responsibilities	8
II. Municipal Solid Waste Characteristics and Preparation	8
A. Sources of Municipal Solid Waste	8
1. On-base Residential	8
2. Off-base Residential	9
3. Ships	10
4. Offices, Hospital, and Retail	11
5. Industrial	11
B. Waste Segregation	11
1. Non-Combustibles	14
2. Recycled Materials	14
3. Tires and Non-Recyclable Batteries	17
4. Wood	17
5. Hazardous Waste/Material	17
6. Combustible Material Not Requiring Processing	18
C. Wood Shredder	18
D. Refuse Mixing and Charging	19
III. The Municipal Waste Incinerator	19
A. Description of the Municipal Waste Incinerator	19
B. Combustion Gases Treatment and Monitoring	22
1. Exhaust Gas Cooling Chamber	22

	Page
2. Combustion Air Preheater	26
3. Quencher Reactor	26
4. Dry Venturi	26
5. Fabric Filter	29
6. Emission Monitoring Equipment	29
C. Auxiliary Equipment	32
D. Plant Operations	32
1. System Monitors	32
a. Video Monitors	32
b. Temperature Monitors	33
c. Pressure Monitors	33
d. Emission Monitors	37
2. Automated Controls	37
a. Combustion Chamber Pressure	37
b. Gas Temperatures	37
3. Manual Controls	38
a. Damper Controls	38
b. Ca(OH) ₂ and Tesisorb Powder Injection Rates	39
4. Control Parameters	39
IV. Air Pollution Control Considerations	41
A. Regulations	41
B. Reporting Procedures	45
C. Hydrogen Chloride (HCl) and Sulfur Dioxide (SO ₂)	46
1. HCl Sources and Control	46

	Page
2. SO ₂ Sources	46
3. Post Combustion Removal of HCl and SO ₂	47
4. HCl and SO ₂ Emissions from the Municipal Waste Incinerator	48
D. Nitrogen Oxides (NO _x)	49
1. Fuel NO _x Control	51
2. Thermal NO _x Control	51
3. NO _x Emissions from the Municipal Waste Incinerator	52
E. Particulate Matter	54
F. Effects of Burning Wood and Plastic on Air Contaminant Emissions	54
V. Recommendations	57
A. Recycling, Composting, and Source Segregation	57
1. Scrap Metals	58
2. Cardboard	58
3. Batteries	59
4. Paper	59
5. Plastics	61
6. Yard Waste Management	66
a. Residential Yard Waste Reuse	67
b. Public Area Yard Waste Reuse	68
B. Operational Changes	69
C. Burning More Wood and Plastics	70
D. Future Studies	71
VI. Conclusions	72

APPENDICES

Appendix A	Start-up Procedures
Appendix B	Sample Emission Charts
Appendix C	Refuse Residence Time Calculations
Appendix D	Sorted Analysis of the Municipal Waste
Appendix E	Model of Municipal Waste Incinerator Results
Appendix F	Proper Emission Reporting Procedures
Appendix G	Tesisorb Specifications
Appendix H	Pollution Control Flow Chart
Appendix I	Sample Collection Containers
Appendix J	SPI Bottle Code
Appendix K	A Homeowner's Guide to Recycling Yard Wastes

LIST OF FIGURES

	Page
I. Site Plan of the Municipal Waste Incinerator and Support Facilities	3
II. Basement Floor Plan of the Municipal Waste Incinerator Building	4
III. First Floor Plan of the Municipal Waste Incinerator Building	5
IV. Second Floor Plan of the Municipal Waste Incinerator Building	6
V. Third Floor Plan of the Municipal Waste Incinerator Building	7
VI. Outside Segregation Yard	12
VII. Waste Segregation Process	13
VIII. Corrugated Cardboard and Aluminum Can Compactor	15
IX. Wood Shredder	16
X. Refuse Crane	20
XI. Auxiliary Burner	21
XII. Stoker Hydraulic Rams	23
XIII. System Flow Diagram of Incinerator and Pollution Control Equipment	24
XIV. Gas Cooling Chamber Water Injection Sites and Control Valve	25
XV. Quencher Reactor	27
XVI. Variable Speed Powder Injection Pumps	28
XVII. Fabric Filters	30
XVIII. Reverse Air Damper	31
XIX. Ash Conveyor	34
XX. The Control Room	35
XXI. Combustion Chamber Video Camera	36

LIST OF TABLES

	Page
I. City of Yokosuka's Air Emission Standards	41
II. Municipal Solid Waste Sorted Analysis after Segregation	44
III. U.S. Air Emission Regulations vs Japan's Regulations	44
IV. Plastic Packaging Material Summary	64

I. Introduction

The scope of this project is to evaluate current operations and equipment, and recommend performance enhancements for the Municipal Waste Incinerator (MWI) located at the Public Works Center (PWC) Yokosuka, Japan. The project is sponsored by PWC. The initial focus of the project was to determine if it is technically feasible to burn additional plastics in the incinerator, and if feasible, what impacts will plastic combustion have on operations and air pollution? During the course of the investigation the project was expanded to address the overall management of solid wastes at the Yokosuka Naval Base.

The Yokosuka Naval Base is located about 50 km south of Tokyo adjacent to the city of Yokosuka, population about 350,000. The Yokosuka Naval Base supports ships located at the base under the Navy's Family Residency Program and other visiting ships forward deployed in defense of the far east.

Japan has established a reputation of being a leader in solid waste management (Hershkowitz and Salerni, 1987). Japan's solid waste management plan depends upon a well balanced system of reuse, recycling, incineration, and landfilling. Given Japan's limited land resources, Japan was forced to limit materials deposited in landfills many years before landfilling became a serious concern within the United States. Even with this strong solid waste management plan, landfills remain a scarce resource within Japan.

The Government of Japan's construction of the MWI at PWC under the Facility Improvement Program (the Facility Improvement Program, funded by the Government of Japan supports the U.S. armed forces presence within Japan by building new and replacement facilities to be used by the U.S. Defense Forces) makes the U.S. Navy a part of Japan's and the City of Yokosuka's solid waste management plan. Since the Navy is

dependent upon Yokosuka's landfill resources and the base is governed under their air pollution regulations, the city is interested in MWI's operations. Thus, the base must make regular reports to the City of Yokosuka to indicate that the City's air pollution regulations are not violated.

After making a one time payment of 4,587,000 yen payment to the City of Yokosuka, the Navy is allowed to haul 9,500 metric tons of trash per year to the City's landfill. This trash may consist of non-combustible trash and incinerator ash. Trash in excess of 9,500 metric tons will be charged at the prevailing rate for other industrial users within the City of Yokosuka. Therefore, PWC is making every effort to ensure that no more than 9,500 metric tons of trash is hauled to the landfill. In fiscal years 1990 and 1991 the base disposed of 6,811 and 5,037 metric tons respectively. These figures indicate that PWC is in no immediate danger of exceeding the 9,500 metric ton limitation.

I.A. General Layout of the Municipal Waste Incinerator and Support Facilities

The MWI site includes a 4,701 m² building, a set of scales, and an outside segregation yard (Figure I). The building houses two incinerators, air pollution control equipment, a segregation yard, a plastic shredder and compactor, and a cardboard and aluminum can compactor (Figures II - V). The scales are used to weigh trucks as they enter and leave the facility with trash.

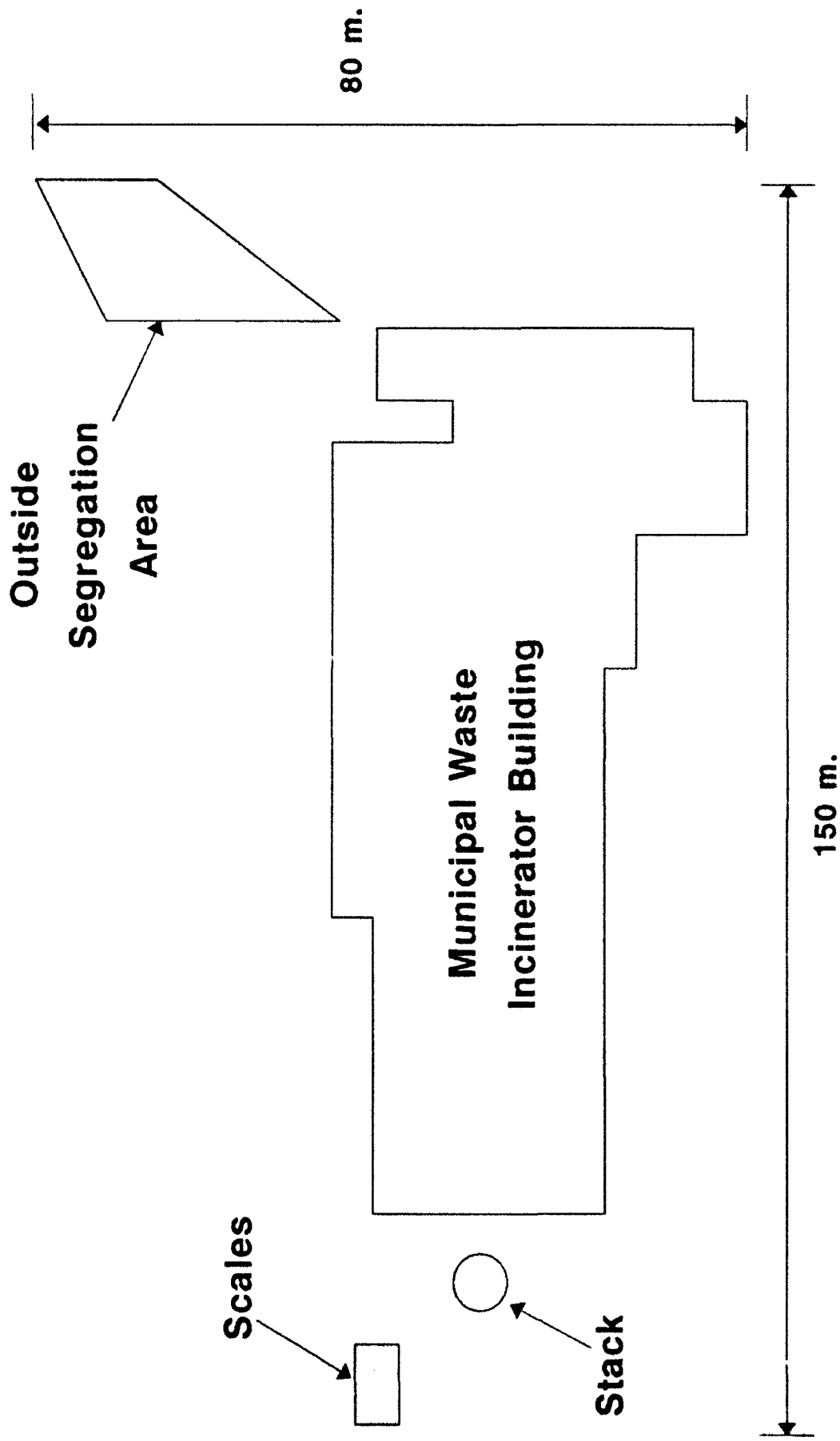

Figure I Site Plan

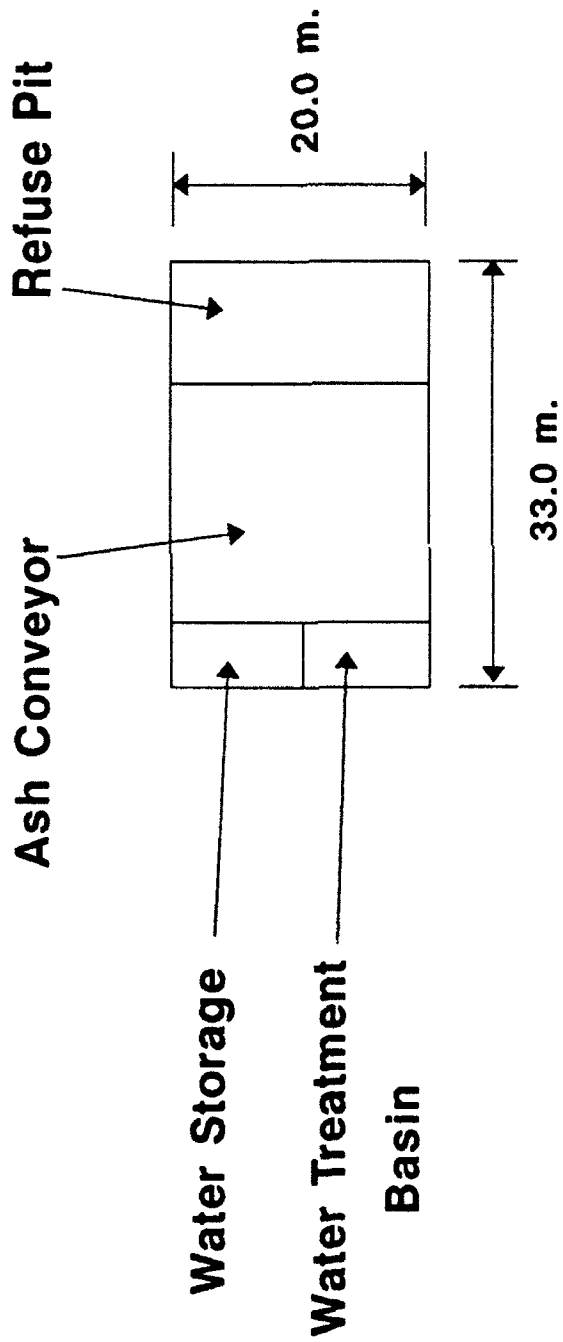

Figure II Basement Floor Plan

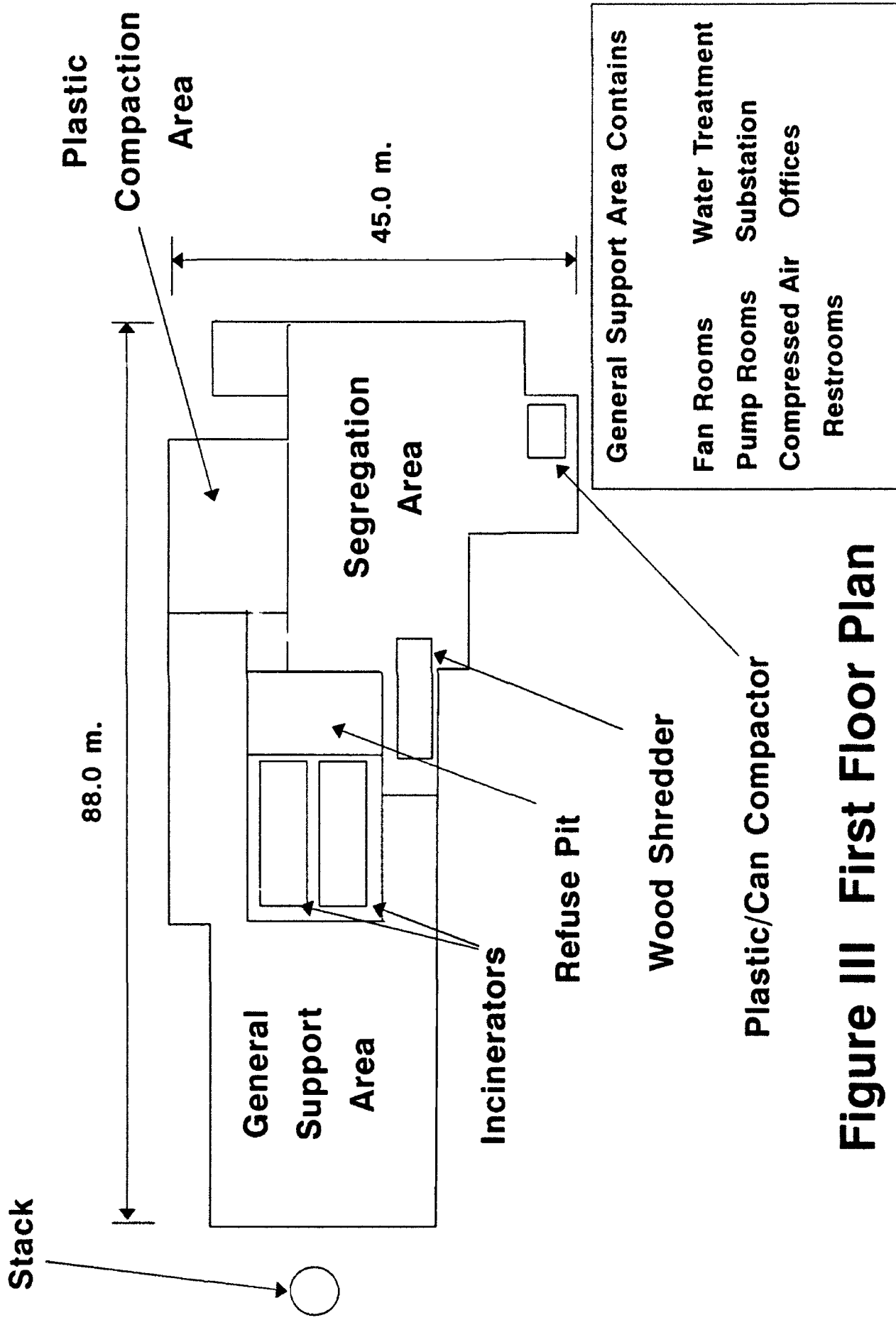

Figure III First Floor Plan

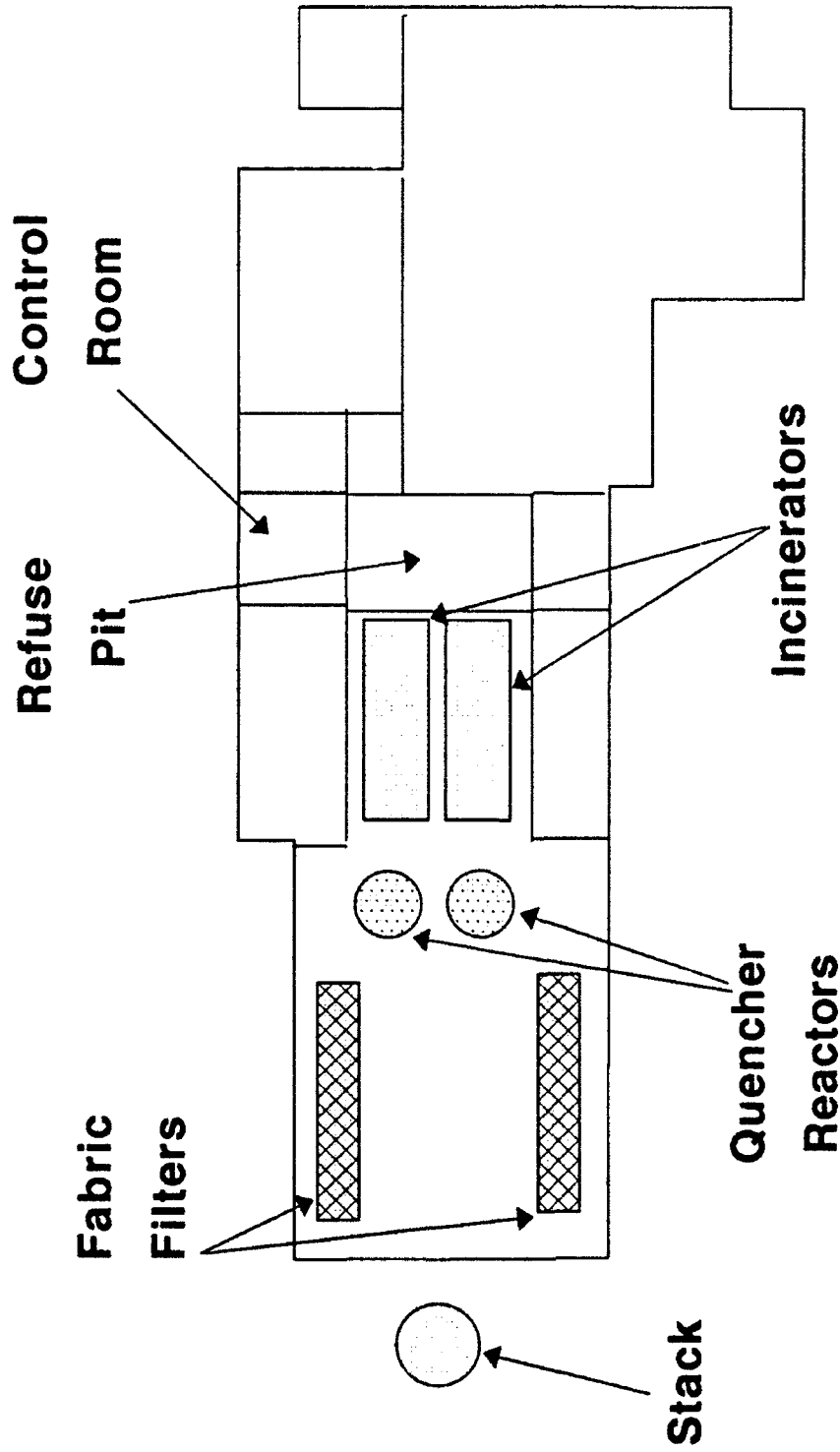

Figure IV Second Floor Plan

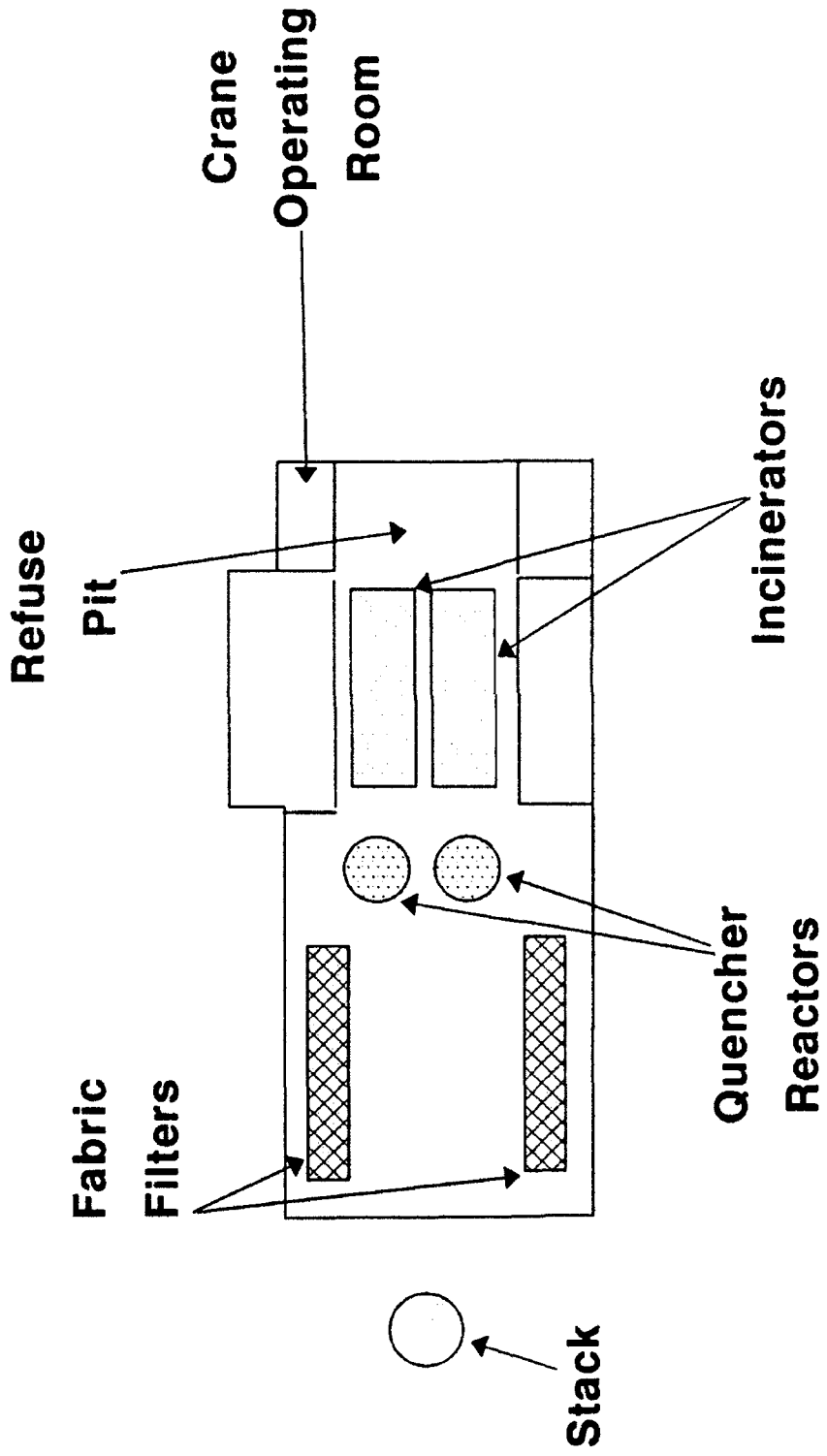

Figure V Third Floor Plan

I.B. Operations and Responsibilities

The incinerator is operated by PWC personnel. The operating personnel include seven high temperature heat plant operators, two low temperature boiler operators, two crane operators, and one supervisor. Contractor personnel are responsible for waste collection and segregation and maintenance of the facility. The two contracts are administered by PWC's Facility Support Contracting Division.

II. Municipal Solid Waste Characteristics and Preparation

II.A. Sources of Municipal Solid Waste

The base occupancy and personnel served by the incinerator are as follows:

- a. On-base residents
- b. Off-base residents
- c. Office personnel
- d. Industrial Workers
- e. Shipboard Personnel

Each of these categories of personnel represent a different municipal waste source.

II.A.1. On-base Residential

On-base residential refuse is collected either from single residence trash cans at

townhouses and duplexes or multi-residence trash containers from the high rise towers, the "H apartments", the Bachelor Officer Quarters, and the Bachelor Enlisted Quarters. The sorted analysis of this waste would be typical for the United States, except minor differences in wastes from packaging. For example, since the commissary and exchange do not usually sell milk and sodas in plastic containers, these bottles will not typically be found within the waste stream. Instead there is a higher frequency of cardboard milk cartons and aluminum cans.

II.A.2. Off-base Residential

Off-base residents have the option of depositing their refuse at neighborhood collection sites; however, a large number of off-base residents choose not to dispose of their refuse within their neighborhood. Instead many off-base residents choose to haul their trash to the base. Prior to about 1990 they disposed of their trash in dumpsters located throughout the base, but are now allowed to dispose of their trash in dumpsters located near the gate that are specifically designated for this purpose.

Stopping this unnecessary flow of refuse through the main gate would make a major reduction in the quantity of waste collected and combusted by PWC. One method to stop this unnecessary flow of waste would be to decree that it shall no longer be allowed, and punish violators. Obviously, this would be unpopular. Instead, the base should look at the root of the problem and take steps to make it as convenient to dispose of the trash off-base as it is to take it to the base.

Off-base residents do not dispose of their trash off-base because it is easier to haul it to the base. In most off-base areas, the refuse must be segregated and set out on different

days to be accepted by the trash collectors. Disposal on base requires no source segregation. Since, most off-base residents make regular trips to the base, it is easier to haul the garbage to the base. However, the requirement to segregate waste to dispose of it off-base and not requiring segregation for on-base disposal may not be the major problem. From personal experience, a compounding problem is that the off-base residents do not always understand the segregation requirements, and what days to set out the materials. When dealing with a different culture and different language the off-base resident finds it easier to haul the waste to the base than it is to find out what they need to do to dispose of the waste off-base. A solution would be to provide complete information and assistance to the off-base residents on how to set up a segregation system to meet the off-base disposal requirements.

Refuse collected from off-base residents is similar in sorted analysis to refuse from on-base residents, except the off-base garbage contains very little yard waste since most houses have small yards, if any.

II.A. 3. Ships

Trash from ships is difficult to characterize. During periods when many ships are in port (could be as many as 18) the quantities of trash collected and incinerated can be several times that when few ships are in port (sometimes as few as two or three). Since, ships provide room and boarding for personnel as well as carry out industrial activities, the trash collected from ships is a mixture of residential and industrial trash. A large quantity of equipment and supplies packaging materials are collected from ships.

II.A.4. Offices, Hospital, and Retail

Office and hospital refuse has a high paper content. Unfortunately the hospital is also a source of needles and other materials not appropriate for general refuse disposal. The presence of these items in the general refuse unnecessarily endangers the lives of refuse handlers. The retail facilities, mainly the commissary and exchange refuse contains large quantities of cardboard and other packaging materials.

II.A. 5. Industrial

Most industrial waste is collected from the Ship Repair Facility, the PWC, and the Naval Supply Depot (NSD) (a major source of wooden pallets). Industrial waste wood and scrap metal is source segregated. Thus, industrial waste has a high concentration of packaging materials and paper.

II.B. Waste Segregation

Most waste segregation is performed at the central segregation facilities. The Morale, Welfare, and Recreation Department has recently begun collecting aluminum cans using large and small collection containers located at various locations around the base. Metals generated by the industrial facilities are segregated at their source and hauled to the MWR collection site for sale by the Defense Reutilization and Marketing Organization (DRMO).

Two central segregation facilities are used. Dumpsters from the industrial areas and berths are segregated within the outside segregation facility (Figures VI and VII).



Figure VI Outside Segregation Yard. In the dumpster to the right plastic and noncombustible materials are collected for direct transportation to the landfill. Recyclable materials are collected on the right.



Figure VII Waste Segregation Process. Waste segregation is a labor intensive process. Plastics, recyclable material, and noncombustibles are placed in the loaders. The remaining combustible material is loaded in a truck and hauled to the refuse pit.

Dumpsters from the residential areas are usually segregated within the inside segregation area directly in front of the refuse pit. To control odor, blowing trash, and an unsightly environment an adequate staff is maintained by the contractor to segregate the trash and remove it from the segregation yards immediately.

II.B.1. Non-Combustibles

Non-combustibles, including most plastics (categorized as non-combustibles by PWC personnel), are immediately placed in a truck or dumpster positioned next to the segregation yard. The non-combustibles are hauled directly from the segregation yard to the landfill. Before a fire destroyed the plastic shredder and compactor plastics were shredded and compacted prior to being put in the landfill. Plans are underway to repair the shredder, but given the inherent danger of another fire within the compactor, the compactor will most likely not be repaired in the near future. Once the shredder is repaired PWC plans to resume shredding the plastic prior to landfilling.

II.B.2. Recycled Materials

Cardboard, aluminum cans, recyclable metals, and batteries are separated for processing and marketing. The waste collection and segregation contractor is allowed to keep proceeds from the sale of recyclable materials. To reduce the bulk, cardboard and aluminum cans are compacted prior to removal from the facility (Figure VIII).

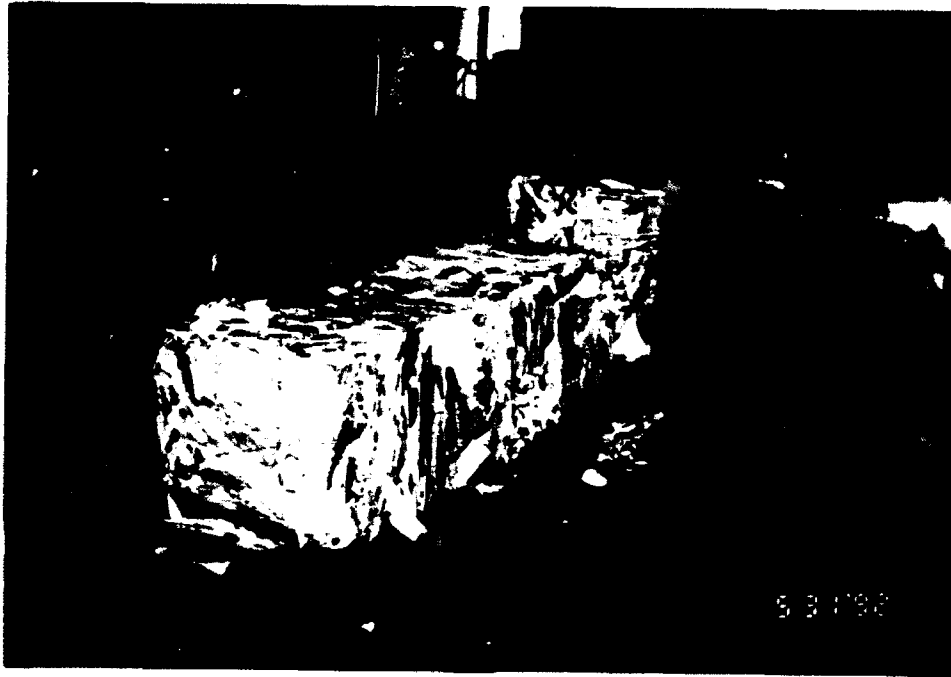

Figure VIII Corrugated Cardboard and Aluminum Can Compactor. Corrugated cardboard (shown in the picture) is compacted to reduce bulk.



Figure IX Wood Shredder. Large pieces of wood are shredded to increase their surface to volume ratio. A hydraulic cylinder presses the wood between offset knives.

II.B.3. Tires and Non-Recyclable Batteries

Tires and non-recyclable batteries are set aside by the contractor and later disposed of at the contractor's expense.

II.B.4. Wood

The majority of the industrial wood is source segregated. Source segregated wood is hauled directly from the collection site to the wood shredder (Figure IX). Large pieces of wood present in the general refuse are removed at the segregation yard and hauled to the shredder. At the shredder, wood is sheared to increase its surface to volume ratio; then remixed with the combustible refuse within the refuse pit. NSD receives thousands of pallets each year from United States sources. These pallets cannot be economically shipped back to the United States, and cannot be sold within Japan since Japan's industry uses a different size pallet size. Thus, excess pallets must be either burned or disposed of off-base. Currently the contractor is required to shred 165 pallets each day. Excess pallets above 165 per day must be disposed of off-base at NSD's expense.

II.B.5. Hazardous Waste/Material

Although, the base requires that all hazardous waste/material be source segregated and not disposed of with the general garbage, periodically hazardous waste/material is found within the general garbage. When the hazardous waste/material is found in the general garbage the hazardous waste management team is notified. The hazardous waste/material

is transferred to the hazardous waste storage site for later transfer to the DRMO.

II.B.6. Combustible Materials Not Requiring Processing

After all the material meeting the above waste categories have been removed, the combustible waste is hauled directly to the refuse pit to await combustion.

II.C. Wood Shredder

The wood shredder consists of a press with offset blades. The segregation contractor is required to operate the wood shredder eight hours per day six days per week. However, during the site visit this requirement was not being met. PWC must decide whether this is a problem. Some reasons this requirement is not being met are: (1) what entails eight hours of operation is not clearly defined in the contract, (2) the operators direct the contractor to limit the wood quantities stating that wood will increase the combustion temperature and increase NO_x formation, (3) the shear is often broken, (4) lack of communication between the MWI operators and contract representatives, and (5) insufficient quantities of wood. These issues will be addressed in the discussion on air pollution and in the recommendations in later chapters.

II.D. Refuse Mixing and Charging

Often the refuse delivered to the refuse pit is not well mixed, especially wood and yard wastes. If the refuse is not mixed there would be many high temperature areas (associated

with large masses of wood or plastic) and other areas where it would be difficult to maintain sufficient combustion (associated with large masses of wet yard waste). Thus, the refuse is mixed using the overhead crane prior to combustion (Figure X). After the refuse is mixed the crane operators use the overhead crane to charge the combustor hoppers. The crane is operated from an enclosed room providing a clear view of the refuse pit and the hoppers. Each refuse load dumped into the incinerator hoppers is weighed and the weight recorded.

III. The Municipal Waste Incinerator

III.A. Description of the Municipal Waste Incinerator

The two incinerators rated at 3.54 tons (3.22 metric tons) per hour were designed and constructed by Takuma Co., Ltd. The incinerators were sized to combust 23 tons of refuse in a eight hour work period. Allowing one and one-half hours for start-up and shut-down the incinerators are often referred to having a rating of 23 tons (20.9 metric tons) per 6.5 hours. They are mass burn, direct flame, stoker fed, with operating temperatures from 800 to 1000°C (current control methods attempt to keep the temperatures in the secondary combustion area between 750 and 950°C . The walls are lined with fire brick. The incinerators are equipped with an auxiliary fuel oil combustor to assist in lighting the refuse after down periods exceeding 24 hours or when the waste has a high moisture content (Figure XI).



Figure X Refuse Crane. The refuse crane is used to mix the refuse within the pit. Mixing the refuse averages out the heating value of the fuel. The refuse crane is also used to charge the incinerator hoppers.

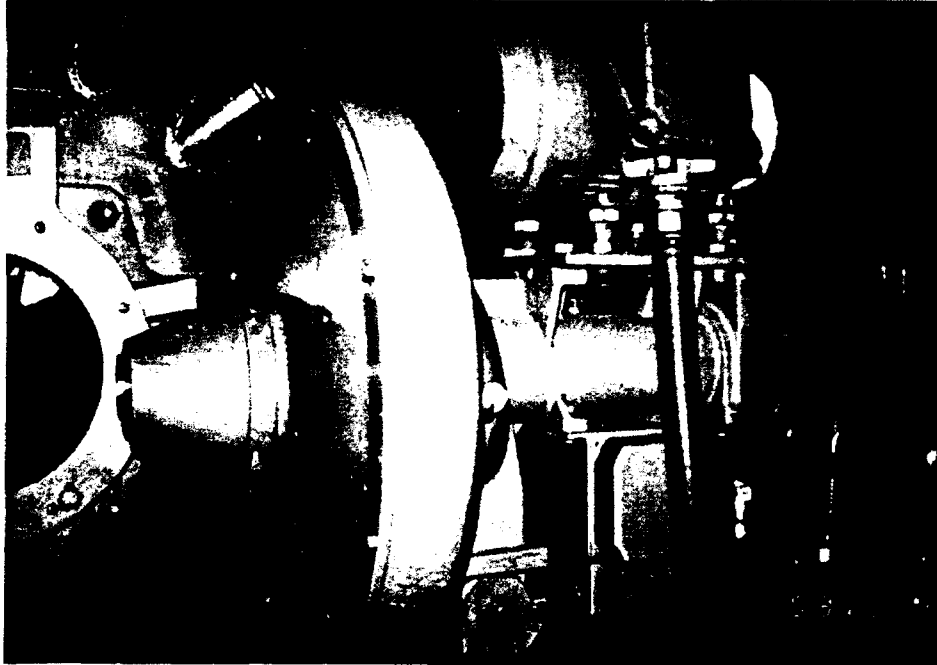

Figure XI Auxiliary Burner. Fuel oil is burned within the auxiliary burner to increase the temperature of the combustor. The auxiliary combustor is usually only required when the combustor has been shut down for over 24 hours, or if the refuse is exceptionally wet. When not in use the auxiliary combustor is removed from the incinerator (as shown). When required the auxiliary combustor is inserted through the opening in the side of the incinerator.

The stoker system consists of a series of grates and hydraulic rams that push the refuse across the grates (Figure XII). The first ram pushes the refuse from the charging hopper onto the drying stoker, where moisture is removed from the refuse through smoldering and initial flame ignition. Next the refuse enters the burning stoker where primary combustion initially occurs. The final grate is the burn-out gate where the ash is allowed to remain up to 150 seconds before being dropped into the ash pit.

During combustion refuse and air undergo multiple chemical reactions forming by-products that leave the combustor as ash and combustion gases. As a result, the ash and combustion gases are laden with a multitude of compounds, many of which are potential pollutants in the environment.

III.B. Combustion Gases Treatment and Monitoring

After leaving the combustion chamber, the combustion gases enter a series of temperature and air pollution control equipment (Figure XIII). The equipment includes the exhaust gas cooling chamber, the combustion air preheater, the quencher reactor, the dry venturi, the fabric filter, and the emissions monitoring equipment discussed below.

III.B.1. Exhaust Gas Cooling Chamber

Within the exhaust gas cooling chamber, water is atomized into the gas stream cools the gases as it evaporates. The feed rate of water is controlled to provide gases entering the quencher at 300°C (Figure XIV). The gases exit the exhaust gas cooling chamber at about 350°C with a 50°C decrease in temperature caused by the combustion air preheater

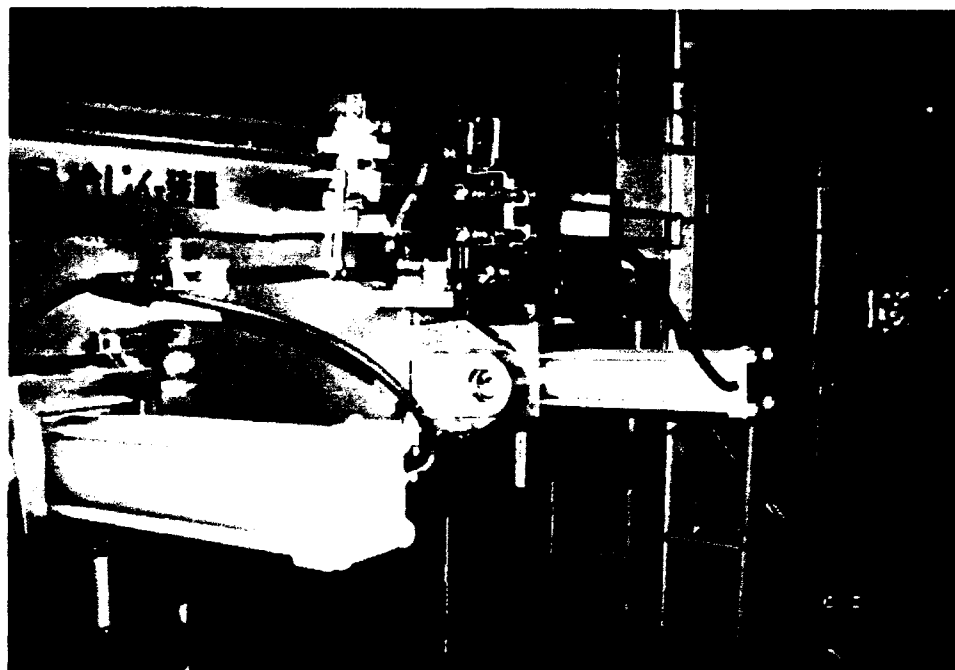

Figure XII Stoker Hydraulic Rams. These hydraulic rams slide the stoker plates within the incinerator. The plates force the refuse through the incinerator.

SOLID WASTE INCINERATION PLANT, BLDG 1829

PWC YOKOSUKA

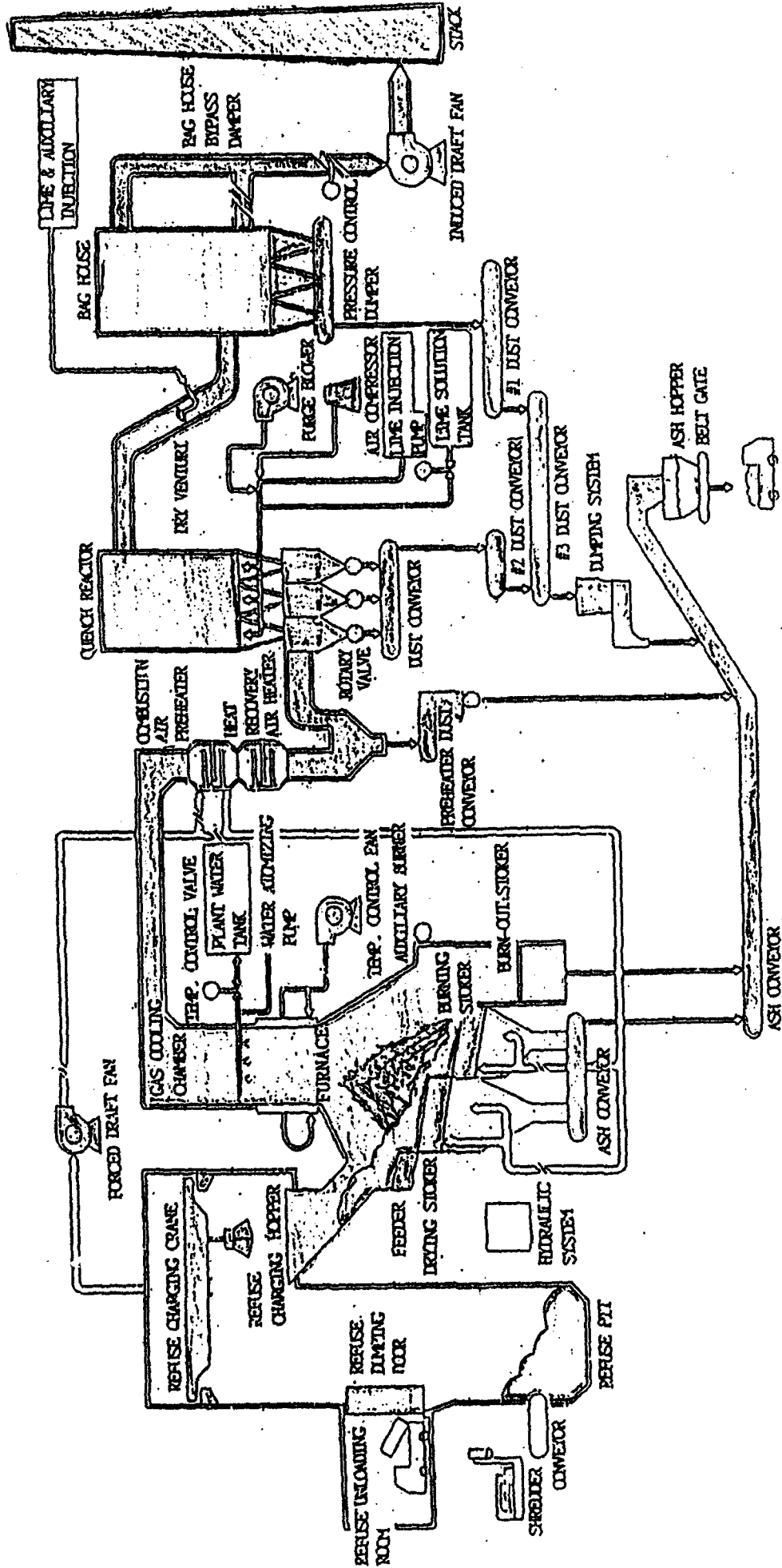

Figure XIII. System Flow Diagram

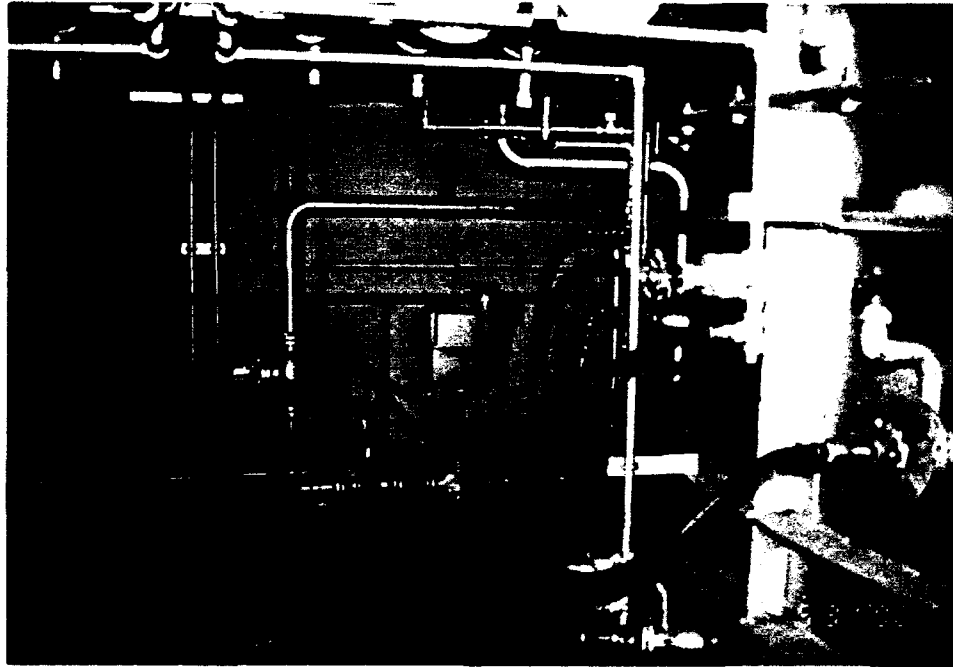

Figure XIV Gas Cooling Chamber Water Injection Sites and Control Valve. Water injected into the gas cooling chamber evaporates to cool the gas. The quantity of water injected is controlled by the valve in the background based upon the gas temperature entering the quencher reactor.

located between the gas cooling chamber and the quencher reactor.

III.B.2. Combustion Air Preheater

The combustion air preheater is a heat exchanger used to preheat the combustion air prior to injection into the burning and drying stokers. The combustion air is preheated to improve drying and combustion during wet refuse conditions.

III.B.3. Quencher Reactor

Within the quencher reactor a lime slurry consisting of calcium hydroxide ($\text{Ca}(\text{OH})_2$) and water is injected into the gas stream (Figure XV). The slurry cools the gas by evaporation and the $\text{Ca}(\text{OH})_2$ reacts with the HCl and SO_2 to form CaCl_2 and CaSO_3 respectively (Figure XVI). The reactions produce dry powder that is collect within the baghouse.

III.B.4. Dry Venturi

The dry venturi is a spool piece in the ductwork that serves as a cake modifier and a reactor for continuing the acid gas neutralization process. $\text{Ca}(\text{OH})_2$ powder and Tesisorb are injected within the dry venturi (Figure XVI). The $\text{Ca}(\text{OH})_2$ continues the reactions with HCl and SO_2 that began within the quencher. Tesisorb is injected to assist in the removal of particles and gases within the fabric filter.



Figure XV Quencher Reactor. The exhaust gas enters the circular quencher reactor at the bottom and exit the top. Within the quencher reactor lime slurry is sprayed into the gas stream. The evaporation of the lime slurry cools the gas stream and the lime reacts with the HCl and SO₂ in the gas stream to form CaCl and CaSO₃.

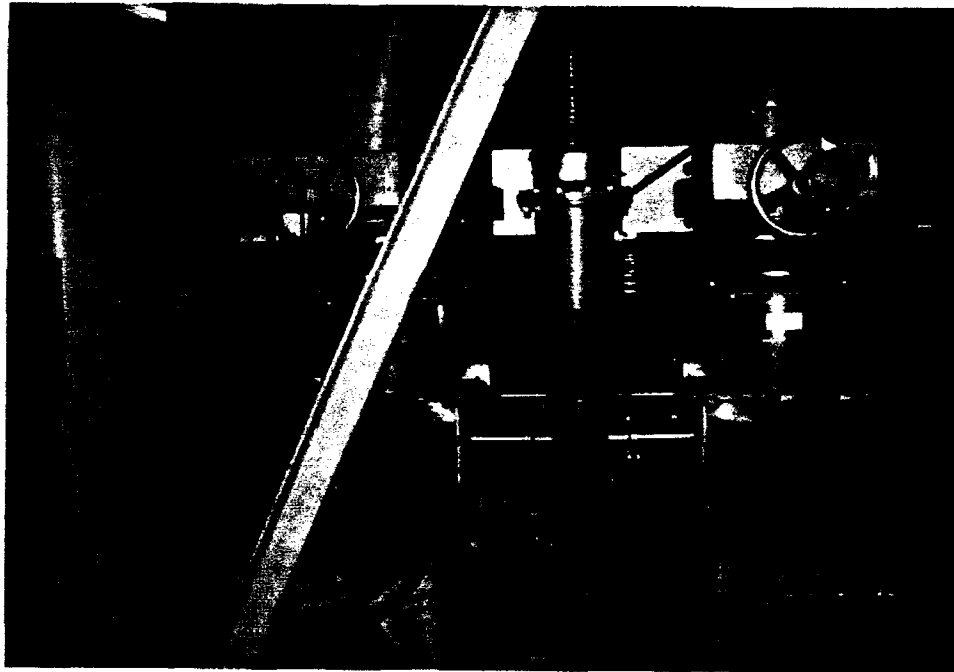

Figure XVI Variable Speed Powder Injection Pumps. Variable speed rotating pumps regulate the quantities of lime $(\text{Ca}(\text{OH})_2$) and Tesisorb injected into the venturi tube.

III.B.5. Fabric Filter

The fabric filter, commonly referred to as the baghouse, consists of 504 tubular fiber glass cloth bags treated with silicon graphite Teflon (Figure XVII). The baghouse is divided into six chambers. Particulate matter within the gas stream is captured as the gas flows through the filters. As the particulate matter collects on the filters it creates a filter cake. The collected filter cake results in an increase in the pressure drop required to pass the gas through the baghouse and an increase in filter cake thickness theoretically increases the cleaning efficiency of the filter. The baghouse is cleaned by a reverse air flow fan in combination with vibration. The total cleaning cycle for the baghouse is three hours. Every 30 minutes one of the six chambers is shutdown for about two minutes. During this cleaning time air is blown through the filters in the opposite direction of normal air flow while at the same time the filters vibrate (Figure XVIII). This activity causes the dust that has collected on the filters to drop to the bottom of the baghouse where it is collected by the fly ash handling system. After the two minute cleaning cycle the chamber goes back on line in normal operation. Thirty minutes later the next chamber is cleaned.

III.B.6. Emissions Monitoring Equipment

Prior to the gas stream exiting through the stack it is continuously monitored for NO_x , SO_2 , HCl, and O_2 content. These values are continuously charted within the control room with the concentrations of NO_x and SO_x adjusted to 12 % O_2 content. The monitoring equipment is automatically calibrated on a daily basis.



Figure XVII Fabric Filter. The fabric filter (sometimes referred to as a baghouse) removes particulate matter from the gas stream. The control panel in the foreground controls the fabric filter cleaning cycle.

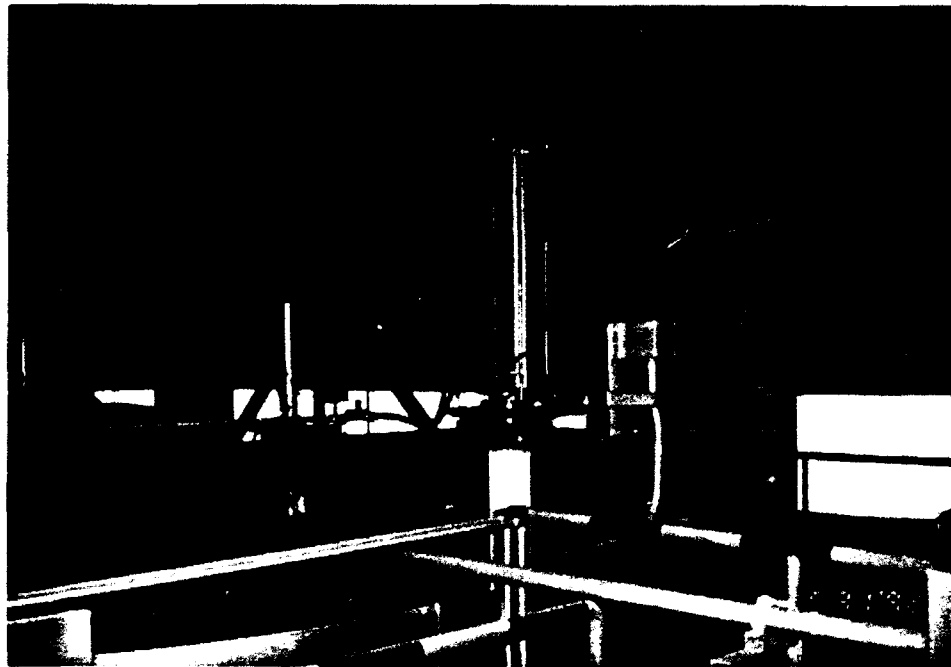

Figure XVIII Reverse Air Damper. Reverse air dampers located at the top of the fabric filter control the air flow within the fabric filter chambers. During the cleaning cycle the reverse air dampers open to allow air to be blown through the fabric filters in the opposite direction as the gas flow. The reverse air combined with vibrators remove the filter cake from the fabric filters.

III.C. Auxiliary Equipment

Ash conveyors transport ash from various locations to the ash hopper where it is loaded onto trucks to be hauled to the landfill (Figure XIX). The ash is quenched in water prior to loading in order to control dust and prevent fires. All of the water used within the plant is treated and reused within the plant. No water is discharged from the plant.

III.D. Plant Operations

After start-up the plant is controlled and monitored from the central control room. Start-up procedures are presented in Appendix A. Usually two operators are stationed within the control room at all times (Figure XX). The operators use a combination of automated and manual controls to manipulate the system based upon flame quality, temperatures, pressures, and emissions.

III.D.1. System Monitors

System performance information is available to the operator on video monitors, temperature monitors, pressure monitors, and emission monitors as described below.

III.D.1.a. Video Monitors

Video cameras are located at strategic locations throughout the plant. The images from these cameras may be observed by the operator on monitors within the control room.



Figure XIX Ash Conveyor. Ash conveyors carry ash from throughout the plant to the ash pit below the incinerators. The ash is quenched in a water bath within the pit and then conveyed to the truck as shown in photo.

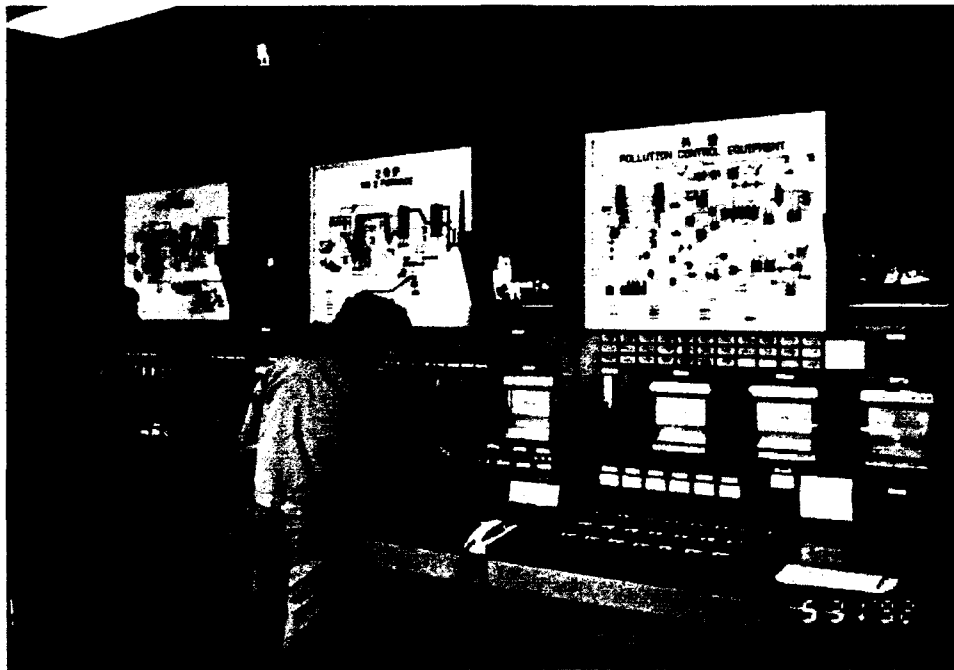

Figure XX The Control Room. Two operators are usually stationed in the control room.

The operator can switch between the various video cameras from within the control room. The primary cameras provide views of the interior of the combustion chamber (Figure XXI) and the smoke stack. By watching the flame within the combustion chamber the experienced operator can determine the quality of the flame, and ensure that the refuse is adequately burned. By viewing the exhaust from the stack the operator can determine whether the emission control equipment is operating properly (Example: Smoke from the stack may be an indication of a ruptured bag in the baghouse).

III.D.1.b. Temperature Monitors

Charts provide continuous recordings of stoker and gas temperatures at various points throughout the system. The operator monitors the stokers' temperatures to ensure that the material limits of the stokers is not exceeded. The stokers' temperatures are kept below 450°C. The gas temperatures are the primary inputs into both the automated and manual controls.

III.D.1.c. Pressure Monitors

Pressure information from various points throughout the system indicate proper operation of pumps and fans.

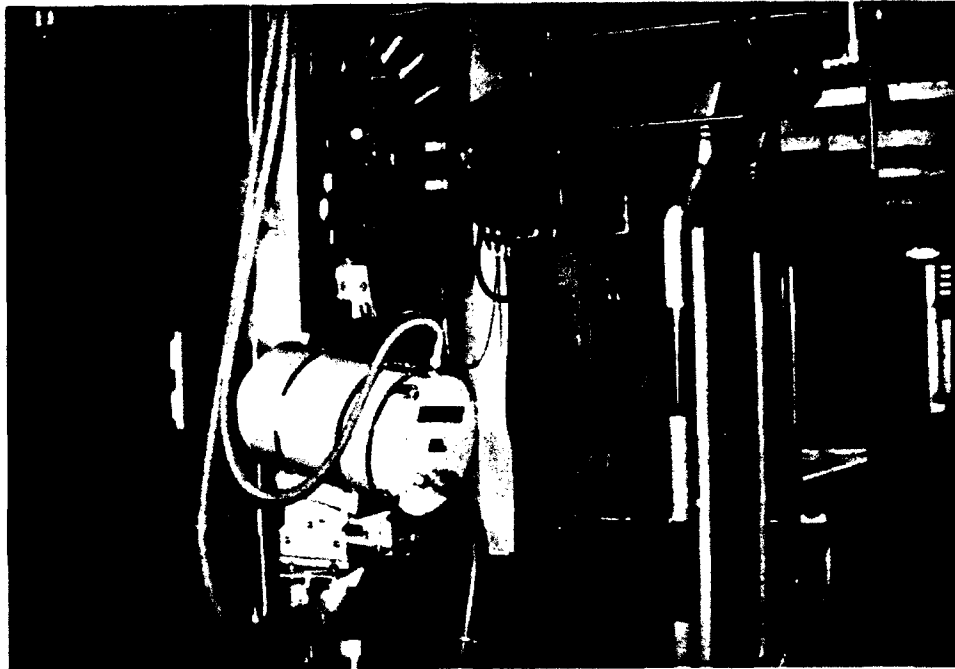

Figure XXI Combustion Chamber Video Camera. The cylindrical video camera is used to monitor the flame condition within the incinerator.

III.D.1.d. Emission Monitors

Emission monitor charts provide continuous readings of NO_x, SO₂, and HCl emissions. The emissions for NO_x and HCl are adjusted for O₂ content in the gas stream with continuous hourly averages. Examples of these charts are provided in Appendix B.

III.D.2. Automated Controls

Automatic controls regulate the combustion chamber pressure, and the gas temperatures at several points throughout the system as described below.

III.D.2.a. Combustion Chamber Pressure

After start-up the pressure within the combustion chamber is automatically controlled through the pressure control damper upstream to the induced draft fan. The combustion chamber pressure is maintained at about negative 10 mm of water.

III.D.2.b. Gas Temperatures

The system automatically regulates the temperature of the exhaust gas entering the quencher and the baghouse. The exhaust gas temperature entering the quencher is adjusted by varying the quantities of water injected within the cooling chamber. The temperature of the gas entering the baghouse is controlled to about 200° C by regulating the slurry injection rate within the quencher.

III.D.3. Manual Controls

The operators may override the automatic controls and directly control several dampers and injection rates of Ca(OH)_2 and Tesisorb.

III.D.3.a. Damper Controls

1) Forced Draft Fan Damper: The forced draft fan provides air pressure to force combustion air into the combustion chamber. The forced draft fan damper controls the total volume of air provided to the drying and burning stokers.

2) Combustion Air Preheater Damper: The combustion air preheater damper controls the fraction of the combustion air that is sent through the combustion air preheater. The combustion air preheater is a heat exchanger that extracts heat out of the exhaust gases to heat the combustion air. When the refuse is wet the combustion air is heated to dry the refuse and increase the flame temperature.

3) Stoker Dampers: The stoker dampers distribute the combustion air between the drying stoker and the burning stoker. The operator adjusts these dampers based upon the refuse moisture content and flame quality.

4) Temperature Control Fan Damper: The temperature control fan damper is used to vary the amount of air that is injected into the secondary combustion chamber above the stoker region (primary combustion chamber).

III.D.3.b. Ca(OH)_2 and Tesisorb Powder Injection Rates

The rate that Ca(OH)_2 and Tesisorb are injected into the venturi are regulated through a variable speed electric motor controlled from the control room. The approximate feed rates of Ca(OH)_2 and Tesisorb are 2.2 kg/hr and 1.2 kg/hr Tesisorb per rpm of the electric motor, respectfully. Up until November 1991 the injection rates were established at 30 rpm (66 kg/hr) for the Ca(OH)_2 and 30 rpm (36 kg/hr) for Tesisorb. In November 1991 the injection rates were changed to 40 rpm (90 kg/hr) for Ca(OH)_2 and 60 rpm (32 kg/hr) for Tesisorb. The increase in injection rates was an attempt to control the NO emissions. The Ca(OH)_2 and Tesisorb have little effect, if any, on the NO emission levels. During the June 1992 site visit it was recommended that these injection rates be lowered. Current information indicates that the injection rates have been reset to the same as they were prior to November 1991. During the site visit it was observed that not all operators were aware of the established injection rates nor did they seem to understand the purpose of these injections.

III.D.4. Control Parameters

Once the start-up procedure is complete, and the automatic systems are operating, the operator's primary functions are to monitor the system and to regulate the flame conditions and the manually controlled temperatures. The temperature most closely monitored and controlled is the temperature within the secondary combustion zone. The secondary combustion zone is the region between the combustion chamber and the cooling chamber where the temperature control air is injected. The system guidelines are to maintain this temperature between 750 and 950°C. The minimum temperature of 750°C is necessary to

ensure proper combustion. According to the operators the maximum temperature of 950°C is maintained in order to limit nitrogen oxides (NO_x) formation and to limit damage to the combustor walls. However, when the temperature occasionally exceeds 950°C by 50 to 100°C there is not an increase in NO_x emissions, and probably no significant damage to the combustor walls.

If the secondary combustion zone temperature rises to about 950°C then the operator increases the volume of temperature control air to the secondary chamber and decreases the air to the stokers. When the secondary combustor temperature approaches 750°C the operator increases the volume of air to the stokers and decreases the volume of air to the secondary combustion zone.

Other factors considered by the operator to determine the ratio of underfire and overfire air include: (1) maintaining the stoker temperatures below 450°C, (2) through observation ensuring that a good burn rate is maintained, (3) limiting the amount of particulate matter in the exhaust gas, and (4) maintain the exhaust gas temperature at the top of the cooling chamber at about 350°C. The fourth criteria is of less importance since, as previously mentioned, this temperature is indirectly controlled by the automatic controller regulating the gas stream temperature entering the quencher.

In addition to controlling the volume and mixing of air entering the combustion chamber, the operator can vary the rate at which the refuse transverses through the combustion cycle. The time it takes the refuse to transverse the combustor is called the refuse residence time. Although an exact residence time is not available, the residence time is estimated to be 20 to 37 minutes for wet refuse and 12 to 24 minutes for dry refuse. The basis for these numbers is provided in Appendix C.

The 12% oxygen adjustment is similar to the 7% oxygen or 12% CO₂ adjustments used within the United States to ensure each plant is evaluated on an equal scale. Different plants have different quantities of excess air in the gas stream. By adjusting the measured emissions to a standard percent O₂ or CO₂ emission concentration, variations due to different quantities of combustion air in the gas stream are eliminated.

According to U.S. regulations the MWI at PWC would be categorized with U.S. standards for facilities with a capacity of 50 - 250 tons (41.7 - 208.3 metric tons) per day. The regulations are based upon the entire facility's burn capacity if operated 24 hr/day. The MWI at PWC would have a capacity of 203.8 tons (169.9 metric tons) per day if operated 24 hr/day. Current U. S. regulations for this size of facility, 50 - 250 tons (41.7 - 208.3 metric tons) per day capacity, are limited to restrictions on particulate matter emissions of 0.18 gr/dscf (6.19 g/Nm³). However, new regulations for facilities with 40 - 250 tons (33.3 - 203.8 metric tons) per day capacity are expected to be released by the U.S. Environmental Protection Agency (EPA) for public comment soon. The EPA has not provided any advance information concerning these regulations except to say that they will be based upon achievable emissions demonstrated by current technologies. Using these guidelines, it is doubtful that the regulations for these small incinerators will exceed current restrictions set by the City of Yokosuka. The most restrictive regulations that are expected would be for the new regulations to match current regulations for incinerators with capacities between 250 - 1100 tons (203.8 - 916.7 metric tons) per day.

The EPA regulations for HCl and SO₂ emissions from existing facilities with 250 - 1100 tons (203.8 - 916.7 metric tons) are based upon 50% removal of the HCl and SO₂ in the gas stream. In order to compare the U.S. regulations and the Japan regulations the amount of HCl and SO₂ in the gas stream prior to entering the quencher must be known. Since this

IV. Air Pollution Control Considerations

IV.A. Regulations

The Navy's policy when operating potentially polluting equipment within another country is to strive to meet the regulation of the host country as well as the applicable U.S. regulations. In operating the MWI, PWC is concerned with meeting Japan's national regulations, the Kanagawa Prefecture (the prefectural government in Japan is similar to a state government within the United States) regulations, as well as the City of Yokosuka's regulations. Since the city's regulations for hydrogen chloride (HCl), sulfur oxides (SO_x), NO_x, and particulate matter are the most stringent they are provided in Table I.

Table I City of Yokosuka's Air Emission Standards

<u>Contaminant</u>	<u>Standard</u>
HCl	25 ppmv adjusted to 12 % oxygen.
SO _x ^a	30 ppmv adjusted to 12 % oxygen.
NO _x ^b	129 ppmv adjusted to 12 % oxygen.
Particulate Matter	.03 g/Nm ³ (Japan Environment Management, 1988)

- a. SO_x includes all sulfur oxides. Although the primary sulfur oxide present within the gas stream is SO₂, typically, there are much smaller quantities of SO₃ present within the gas stream.
- b. NO_x includes all nitrogen oxides. Although the primary oxide of nitrogen present within the gas stream is NO, typically, there are much smaller quantities of NO₂ present within the gas stream.

The EPA regulations for HCl and SO₂ emissions from existing facilities with 250 - 1100 tons (203.8 - 916.7 metric tons) are based upon 50% removal of the HCl and SO₂ in the gas stream. In order to compare the U.S. regulations and the Japan regulations the amount of HCl and SO₂ in the gas stream prior to entering the quencher must be known. Since this information is not available from the PWC MWI, it will be estimated using a municipal waste incinerator modelling program developed by Richard Simek and Dr. Mark Rood of the University of Illinois (Simek and Rood, 1990).

The program requires a sorted analysis of the waste being combusted at the facility. The sorted analysis was developed starting with the sorted analysis performed by the Navy Civil Engineering Laboratory in 1985 followed by making some assumptions as to the quantities of each type of waste removed from the waste stream during the segregation process. The analysis is presented in Appendix D; the resulting sorted analysis is presented in Table II. The inputs, assumptions, and results of the MWI model are presented in Appendix E. The computer model results that will be used to compare the regulations in Japan to the U.S. regulations are that the emissions for HCl and SO₂ are 88.5 ppm_{dv} (@7.0% O₂) and 666.1 ppm_{dv} (@7.0% O₂) respectively. Using these values the U.S. regulations for existing facilities with 250 - 1100 tons (203.8 - 916.7 metric tons) per day capacity compared to the City of Yokosuka regulations are presented in Table III.

Table II Municipal Waste Sorted Analysis After Segregation

<u>Sorted Item</u>	<u>Percent Mass</u>
Mixed Paper	24.1
Mixed Plastics	6.5
Leather & Rubber	3.2
Textiles	5.8
Wood	30.3
Food Wastes	10.0
Yard Wastes	9.3
Glass	2.3
Metal	2.1
Fines	6.4

Table III U.S. Air Emission Regulations (Hootman and Vernet, 1991) vs Japan's Regulations

<u>Air Contaminant</u>	<u>U.S. EPA Standard Existing Facility 250 - 1100 tons/day</u>	<u>U.S. EPA Standard Adjusted to ppmv (@ 12% O₂)^a</u>	<u>City of Yokosuka Standard ppmv (@12% O₂)</u>
HCl	50 % Reduction	197.1	25
SO ₂	50 % Reduction	26.2	30
NO _x	Not Regulated		129
Particulate Matter	1.03 g/dscm ^b		.03 g/dscm
Organics, i.e., dioxins and furans	125 ng/dscm ^c		Not Regulated

a. Adjusted using estimated incinerator emissions from the MWI Model

b. gr/dscf = grams per dry standard cubic foot @ 7.0% O₂

c. ng/dscm = nanograms per dry standard cubic meter @ 7.0% O₂

From this comparison the new U.S. EPA regulations should be about as strict as those currently required by Yokosuka and being met by the PWC incinerator. Actual emissions of contaminants will be discussed later. Even though the Japanese regulations do not pertain to organics, the current equipment used at PWC that combine a spray dryer and Tesisorb injection with a baghouse have demonstrated a removal efficiency of 95 to 99.75% for dioxins (Teller, 1991). Thus if the new U.S. EPA regulations for facilities with capacities over 40 tons (33 metric tons) per day cover organics the only additional requirement to meet U.S. regulations may be to test the gas stream for organics. The tests would probably indicate that the facility is within compliance with potential U.S. EPA regulations.

Additional regulations can be anticipated on other pollutants that are present within typical MWI gas streams. The EPA is considering regulations for pollutants such as mercury, lead, and other heavy metals. It is unknown when these regulations will be implemented.

B. Reporting Procedures

To demonstrate that the facility is meeting the City of Yokosuka's regulations the city requires periodic emission level reports. Since PWC falls outside of the EPA regulating arm they are not required to submit reports to EPA; however emission data should be made available to the various inspection teams that routinely visit the facility.

The Japanese and U. S. regulations are written to allow the emission level to be exceeded for short periods of time. The regulations are based upon a 24 hour geometric average. In simple terms this means that the emission for each hour are averaged and then the average hourly emission rates are averaged over all operating times during a 24 hour period. The City of Yokosuka requests that the emissions be reported as hourly averages.

The PWC MWI monitoring equipment charts the average emissions each hour for both NO_x and HCl. Thus, in order to properly report these values the maximum point reached by the averaging lines should be reported for each hour. For NO_x emissions this means that the highest point reached by the black line during one hour period should be reported. For HCl the highest point reached by the green line during one hour period should be reported. Examples of proper reporting procedures with the lines labeled are provided in Appendix F; in the original charts the lines will be colored as previously mentioned.

IV.C. Hydrogen Chloride and Sulfur Dioxide

IV.C.1. HCl Sources and Control

HCl is formed from the combustion of chlorinated wastes. The main sources of chlorine within the waste stream appear to be plastics, leather, and rubber. Minor sources of chlorine are paper, textiles, wood, food wastes, and yard wastes (Simek and Rood, 1990). HCl can be controlled by limiting the quantities of high chlorine content waste fuels; however, to meet regulations by this method alone would severely limit the types of wastes that could be burned within the incinerator. Therefore, removal of HCl after formation is required to meet emission requirements.

IV.C.2. SO₂ Sources

SO₂ is formed through the oxidation of the sulfur contained in the fuel during combustion. Nearly all MSW contain some quantity of sulfur and the combustion

temperature has very little impact on the formation of SO_2 . Therefore, SO_2 must be removed after its formation in order to meet emission levels, if sulfur containing materials cannot be removed from the feed stream.

IV.C.3. Post Combustion Removal of HCl and SO_2

Since HCl and SO_2 are both acid producing gases and are soluble in water, the removal processes are similar. One of the most common methods used to remove these gases from exhaust streams is through absorption in combination with chemical reaction. Absorption involves mass transfer of a soluble gaseous component to a solvent liquid in a device that promotes intimate contact between the gas and the liquid (Flagan and Seinfeld 1988). The quencher used within the PWC MWI is such a device in which the $\text{Ca}(\text{OH})_2$ slurry absorbs HCl and SO_2 and chemically reacts with the gases to form CaCl_2 , CaSO_3 , and H_2O .

Adsorption is also used as a removal method for HCl and SO_2 within the PWC MWI system. Adsorption is employed to remove low concentrations of gases from exhaust streams by causing gaseous solutes to come in intimate contact with a porous solid to which the solute will adhere (Flagan and Seinfeld, 1988). Within the PWC MWI adsorption and chemical reactions occur in the venturi tube and baghouse as a result of the injection of powder $\text{Ca}(\text{OH})_2$ and Tesisorb. Adsorption and chemical reactions continue from the injection site until the gases have passed through the baghouse.

"Tesisorb" refers to a process owned by Research Cottrell Environmental Services of Summerville, New Jersey. The process involves using a non-reactive, non-hydrophilic material that increases the surface area on the filter cake to improve gas removal efficiencies. The process was designed to increase collection efficiencies without significant cost

increases. The specifications used by PWC (Appendix G) are recommended by Research Cottrell, but the actual material can vary from these specifications.

What is designed to be very low cost in the United States has turned out to be very expensive in Japan. Material that meet the Tesisorb requirements costs about \$5.00 per metric ton in the United States is costing \$1200.00 per metric ton in Japan.

IV.C.4. HCl and SO₂ Emissions from the Municipal Waste Incinerator

Historically PWC has met HCl and SO₂ emission regulations with very little difficulty. SO₂ emissions have typically been between 0 to 20 ppmv @ 12.0% O₂. However, during many periods the SO₂ chart reads less than zero indicating that there may be a problem with the SO₂ monitor. HCl emissions have been below the required 25 ppmdv at 12% O₂ as required by Japanese regulations. Periodically HCl emissions have exceeded this limit for short periods; however, there were no days observed for which the geometric mean exceeded 25 ppmdv at 12% O₂.

An interesting trend in HCl emissions was observed. After an initial spike in HCl emissions immediately after start-up, the HCl emissions drop to a relatively low level (about 5 to 10 ppmv). Then the emission concentration tends upward for about two and one-half to three hours before leveling off.

The trend in the HCl concentration appears to be related to the baghouse cleaning cycle. A complete baghouse cleaning cycle takes three hours. A correlation between the baghouse cleaning cycle and HCl removal efficiency is expected, but the observed correlation is opposite to that expected. Theoretically as the filter cake builds up on the filters more HCl will be removed from the gas stream since the gas stream passes through the filter

cake it can react with the unreacted Ca(OH)_2 which has been captured within the filter cake. A good porous filter cake will not only provide more unreacted Ca(OH)_2 but also provide additional surface area for the HCl and Ca(OH)_2 to interact.

But in the PWC MWI as the filter cake develops, HCl emissions are increasing. An increase in emissions does not necessarily indicate a reduction in HCl removal efficiency, if HCl production from the combustor increased during the first three hours the same trend would be observed. Since raw emission data from the combustor is not available, we cannot be certain that there is not an increase in HCl production during this time; however, this is very unlikely. Chlorine content in the fuel would drive differences in HCl production, but there is no consistent difference between the fuel supplied to the combustor at start-up and after three hours of operation. Thus, the conclusion is drawn that HCl removal efficiencies decrease as the filter cake increase and then levels off as the filter cake reaches a relative constant thickness.

The reason for this trend of increasing HCl emissions with increasing filter cake development is undetermined. One possible reason would be broken filters within the baghouse. In this case when the filter was relatively clean the pressure drop caused by the filter is small. With a low pressure drop very little gas would be forced through the ruptured filters. Therefore, almost all of the gas would pass through filters resulting in a good removal efficiency. As the filter cake develops the pressure drop required to force the gas through the filters increases. The pressure drop increase would force larger volumes of gas through the ruptured filters. Thus, less gas would pass through the filters and more gas would pass through the baghouse unfiltered. If this were the case there should be a noticeable increase in particulate matter emissions, which may be observable at the stack. This scenario is unlikely on a continuous basis if the baghouse is periodically checked for torn filters and the

pressure drop in the baghouse is recorded hourly.

IV.D. Nitrogen Oxides (NO_x)

NO_x differ from HCl and SO₂ because their formation can be greatly effected through combustion practices, and once they are formed, the removal of NO_x is much more difficult and expensive. The PWC MWI does not have any NO_x removal equipment, thus meeting emission standards is dependent upon preventing the formation of excessive quantities of NO_x. The pollution control equipment flow chart (Appendix H) shows that NO_x reacts with Ca(OH)₂ to form Ca_xNO_x; however, this reaction is so slow and energetically unfavorable that an insignificant quantity of the NO_x is removed from the gas stream.

Since meeting NO_x emission regulations depends upon preventing its formation, it is important to understand how it is formed and then make the proper adjustments to the combustion process to prevent it's formation. The two primary sources of NO_x are fuel NO_x and thermal NO_x. Fuel NO_x is formed upon oxidation of the nitrogen in the fuel according to the following equation:

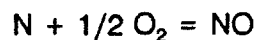

Thermal NO_x results from dissociation of N₂ in the combustion air and oxidation of nitrogen atoms. Thermal NO_x formation is very dependent upon the adiabatic flame temperature. At adiabatic flame temperatures below 1760°C insignificant quantities are produced (Tillman et al., 1989).

IV.D.1. Fuel NO_x Control

Fuel NO_x control is accomplished through starving the combustion zone of O₂ in order to allow the formation of N₂ instead of NO. However, sufficient O₂ must be provided to ensure complete combustion; otherwise, excessive CO will be present within the exhaust gas. A method that meets both criteria is two stage combustion. In two-stage combustion the goal is to maintain fuel-rich gases long enough for the N₂ forming reactions to proceed. The gases are then subjected to a fuel-lean zone where excess O₂ is provided in order to ensure complete combustion. Since the nitrogen from the fuel has been given time to combine to form N₂ prior to reaching the fuel-lean zone, there is less nitrogen available to combine with the excess O₂ in the fuel-lean zone. This results in less NO being formed in the overall combustion process. The PWC MWI indirectly employs this method of NO_x control when the temperature control air is increased and the underfire stoker air is decreased.

IV.D.2. Thermal NO_x Control

To control thermal NO_x the flame temperature should be maintained below 1760°C, but flame temperatures within municipal waste incinerators do not typically exceed 1760°C, except in local "hotspots" where high concentrations of materials with high heating values exist momentarily. Except where the hot spots occur thermal NO_x should not be a problem within the incinerator. Therefore, thermal NO_x can be controlled by limiting the quantities and size of materials with high heating values within the combustor.

IV.D.3. NO_x Emissions from the Municipal Waste Incinerator

NO_x emissions have consistently been the most troubling pollutant to keep below Yokosuka City's regulations of 129 ppm_{dv} at 12% O₂. A random sampling of PWC's emission charts demonstrated that the NO_x emissions often are as high as 150 ppm_v during a given one hour period; although, the geometric mean for each 24 hour period ranged from 80 to 125 ppm_v at 12% O₂. In October 1991 there were several days when the geometric mean was between 130 and 150 ppm_v, but PWC personnel reported that the O₂ adjustment was not working properly at that time. Therefore, when changes are considered in the plants operation NO_x emission will be one of the first concerns, especially when considering changes to the combustion process.

Initially one might consider that anything that might increase the combustion temperature will adversely effect NO_x emissions. However, review of historical data and further analysis has shown that this is not true. Historically when the temperatures within the secondary combustion have been high the NO_x emissions have gone down. The opposite trend is observed when the secondary combustion temperatures are low. Although, we do not have data available to indicate the flame temperature, it will be assumed that when the secondary combustion temperature increases, the adiabatic flame temperature increases due to mixing of combustion air in the secondary combustion zone.

If thermal NO_x was a major contributing factor to NO_x emissions then NO_x emissions would increase at these higher temperatures. Since, NO_x emissions have actually decreased at higher temperatures, what little increases there are in NO_x emissions due to thermal NO_x, if any, must be more than offset by a decrease in fuel NO_x. The temperature control methods used within the plant contribute to significant reductions in fuel NO_x formation.

The temperature control scheme, as discussed in Chapter III, floods the primary combustion zone with air when the temperature within the secondary combustion zone is low (750 - 850°C) and restricts air to the primary combustion zone when the temperatures within the secondary combustion zone approach or exceed 950°C. Thus, when the secondary combustion zone temperatures are low, the excess O₂ available within the primary combustion zone allows formation of NO. When the secondary combustion zone temperatures are high, the primary combustion zone is O₂ starved, restricting the formation of NO. Also many of the low heating value fuels such as textiles, food wastes, and yard trimmings have a higher nitrogen content than wood and plastic. Wood in particular has a very low nitrogen content, with typical values of 0.24 % by weight, compared to 0.85 for plastic, 0.89 % for yard trimmings, 1.13 % for food waste, and 3.11 % for textiles (Appendix E).

This rationale would indicate that any changes to the combustion process that would require less underfire air and more temperature control air would decrease the formation of NO_x. Thus if the heating value of the fuel is increased, the flame temperature and the temperature within the secondary combustion zone will tend to increase. To keep the secondary combustion temperature under control the operator will be forced to provide more overfire air and less underfire air. As long as the flame temperature remains below 1760°C the fuels with larger heating values should produce less NO_x. However, with higher heating value fuel, controlling the secondary combustion and stoker temperatures becomes more difficult. This would explain the apparent reluctance of the operators to increase the quantities of wood and plastic burned within the incinerator.

IV.E. Particulate Matter

Particulate matter emissions are a function of the ash and inert content of the fuel, the firebox configuration, and combustion conditions. Factors which may influence particulate matter production that are under the control of the operator are residence time of the solids within the combustor, the volume of excess air, and the ratio of underfired to overfired air; however, these factors also effect other emissions and operational factors. Since particulate matter is efficiently removed from the gas stream by the baghouse, little effort is made to control particulate matter emissions using these factors.

Particulate matter emission levels are not available except those obtained during the incinerator's start-up tests in 1988. During the start-up tests the average particulate matter concentration was 0.008 g/Nm^3 which is substantially below the maximum concentration of 0.03 g/Nm^3 . Given the excellent particulate matter removal equipment employed at the incinerator these results are not surprising. PWC personnel indicate that tests will be performed periodically in the future to ensure that particulate matter emissions remain below regulatory limits.

IV.F. Effects of Burning Plastics and Wood on Air Contaminant Emissions

The average higher heating values of plastic and wood are about 12,750 and 7,000 Btu/lb respectfully. Since their heat value is above the average heat content of the refuse any increase in the quantities of plastic and wood to be burned will increase the overall heating value of the fuel, and the flame temperature. An increase in flame temperature will tend to increase the temperature within the secondary combustion chamber requiring a

reduction in underfire air accompanied with an increase in the overfire air. Thus, burning additional quantities of wood and plastics should decrease the level of NO_x emissions, unless hotspots occur within the fuel to produce significant thermal NO_x . Also since wood has a much lower nitrogen content than many of the low heating value fuels, burning wood may have an additional benefit of reducing the nitrogen available to form NO .

Since some plastics contain substantial amounts of chlorine and sulfur there can be an increase in HCl and SO_2 formation as the fuel percentage of plastic increases. However, the chlorine contents of plastics other than PVC are not large enough to cause significant HCl emission increases. Thus PVC should be the last plastic added to the combustible fuel. PVC is a durable plastic often used in construction and plumbing. It is also used in some food, shampoo, oil, and household product containers. In Chapter VI information is provided on how PVC plastics can be identified.

Assuming the SO_2 emission data is correct, even fairly moderate increases in SO_2 emissions will not cause compliance problems.

Other impacts of increasing plastic and wood combustion rates are related to the operations of the system. Since the additional plastic and wood content will tend to drive up the combustion temperatures, the operators will have to more closely monitor the secondary combustion temperatures. Air dampers may have to adjusted more often to ensure that the temperatures remain within guidelines. Although, the operators have expressed reluctance to increase the plastic and wood content for this reason, it should not be beyond their capabilities to control the temperatures with fuels with high heat content.

As plastic and wood quantities increase, clinkers may form within the combustor. Clinkers are the result of ash melting to form clumps as a result of temperatures exceeding 1200°C (Tillman et al., 1989). An effective way to reduce the potential of clinker formation is

through shredding the plastics and through mixing the refuse prior to combustion to minimize the concentrations of materials with large heating values. PWC will be able to shred plastic again once the shredder is repaired.

To get an idea of the impacts of combusting additional plastics as well as other operating considerations a site visit was made to the Fujisawa City MWI. The MWI at Fujisawa City is of similar design to the PWC MWI and combusts all the plastics collected. This even includes appliances and furniture which are shredded prior to combustion. The Fujisawa incinerator probably combusts less wood than is currently combusted at PWC. Fujisawa City has not experienced any problems with clinkers or with maintaining emission levels well below those required of PWC. The pollution control equipment on one incinerator at Fujisawa city is very similar to that used at PWC. The other incinerator has an electrostatic precipitator (ESP) instead of a baghouse. The only advantage that Fujisawa City has is in regards to NO_x control. In the Fujisawa City facility a portion of the exhaust gas is recirculated back to be mixed with the underfire air. This recirculated exhaust gas contains less O_2 than air, so it helps to starve the primary combustion zone of O_2 in order to decrease the production of NO_x . This would be a possible retrofit for the PWC facility if deemed necessary at a future date.

The Fujisawa City MWI operations are enhanced by an automatic temperature controller for the secondary combustor temperature. This unit automatically regulates the ratio of overfire air to underfire air as well as the amount of exhaust gas recirculated. Addition of this type of controller on the PWC MWI could be possible, although an expensive retrofit. Lack of exhaust gas recirculation and automatic temperature control should not be reasons to prevent PWC from increasing the wood and plastic ratio in the fuel. The emission levels obtained at Fujisawa City are well below those required to meet regulations (ie.

Fujisawa City emissions for NO_x are about 50 ppmv).

VI Recommendations

VI.A. Recycling, Composting, and Source Segregation

In both the United States and Japan recycling, composting, and source segregation are popular concepts. Concerns over the loss of landfill facilities, the increasing cost of using these facilities, and depleting natural resources have given rise to a popular movement to use and reuse all our resources to their full potential. Although, recycling and composting will not in themselves solve these problems in either country, they have and will continue to be a valuable part of the waste management equation.

"Japan is leading the way in waste management" (Hershkowitz and Salerni, 1987) with a very strong emphasis on recycling in conjunction with incineration. This is the type of environment that the Yokosuka Navy base is located. With this environment and new people arriving daily that have been educated in the new recycle and reuse environment within the United States it is prime time for the Yokosuka Base to move forward in support of recycling and reuse. The Yokosuka Navy Base has some strong programs to recycle metals, cardboard, and batteries, but there is potential to do more.

Not all refuse can be recycled, and not all refuse that is recycled can be economically source segregated. Factors that may impact whether a category of refuse can be economically recycled or segregated include the presence of markets to buy the recyclable material, handling difficulties, transportation, the relative difficulty of source segregation versus central segregation, the potential of contamination when mixed with general waste,

and the degree of participation by the generators in source segregation programs. These factors will be considered as each category of recyclable waste is considered.

VI.A.1 Scrap Metals

Only a small percentage of the scrap metal generated on the base makes it's way into the general refuse. The revenue potential of these commodities has been recognized by MWR and they seem to be making a strong effort to segregate these commodities prior to them reaching the general refuse. Observation of the waste stream indicates that significant quantities of aluminum cans are still getting to the general refuse from the ships and industrial areas. MWR may want to investigate how to capture aluminum cans from these sources. This investigation is outside the scope of this project.

VI.A.2. Cardboard

The market for cardboard is well established as the contractor now recycles corrugated cardboard and collects all revenues. Corrugated cardboard generated by the commissary and the exchange could be easily segregated before entering into the general waste stream. This could be accomplished by having dedicated dumpsters at the commissary and the exchange for corrugated cardboard. Many of the crates received by the industrial facilities and ships have wood stapled to cardboard. This wood is usually separated from the cardboard at the segregation yard. It would not be reasonable to expect the generators to separate the wood prior to disposing the cardboard.

Thus, if sufficient savings can be negotiated in the refuse handling contract, then

source segregation should be considered at the commissary and the exchange. Since the contractor has the equipment to readily separate the cardboard from the wood it is probably more cost effective to continue to segregate the crates at the segregation yard.

VI.A.3. Batteries

Acid batteries when drained can be sold for their lead content, but if they are not drained they are a hazardous waste. From past experience most of the batteries from the industrial facilities are drained and sold instead of discarding to the general waste stream. Most acid batteries that are found in the general refuse are from personal vehicles. To prevent this problem the base should initiate a battery drop-off point where personnel can drop off their used battery at no cost.

When dry batteries are found in the general refuse they are segregated by the contractor. The contractor is responsible for disposing of the dry batteries. The dry batteries have no recycling value and disposal is at the contractor's expense.

VI.A.4 Paper

Paper offers the greatest potential for increased recycling. Currently there is no significant efforts being made to recycle paper. Since paper can be easily soiled when mixed with general refuse or even allowed to get wet, recycling paper would benefit from source segregation. The two potential areas in paper recycling are newspapers and office paper. Within Japan there are strong markets for recyclable paper, since Japan has limited natural

resources. The market is there, the base just needs to address how to segregate the paper and get it to the markets.

The recommended approach to recycling newspapers is to establish a central drop-off point as near to the commissary and exchange as possible. All on-base and off-base personnel make regular trips to the commissary and exchange; collection stations that are easily accessible by people visiting these areas will make recycling as convenient as possible without initiating a curb side pick-up. This system of locating all recycling containers in one convenient location is used in many small cities and on bases throughout the United States. With these arrangements, citizens may deposit recyclable materials on the way to do their shopping. Although participation in these programs have not reached the same levels as those with curbside pick-up, these programs have made significant reductions in waste being deposited in landfills. Appendix I shows some examples of multiple compartment containers that can be used to collect recyclables. One of these types of containers or several of the "igloo" containers already used by MWR to collect aluminum cans could be used for this purpose as long as the paper collection container will prevent most water from entering the container.

Curbside pick-up for recyclable materials is not recommended. Curbside collection programs require a sizable investment and operating budget that could not be recouped with such a small service area as the base.

Office paper can be easily segregated within the office environment by using separate containers for recyclable paper and general trash. There are generally three different approaches available. One approach is to provide each individual with two different containers, one for recyclable paper and the other for general trash. The second approach is to provide strategically placed containers near copy machines, printers and central locations

where individuals can drop off their recyclable paper. The third approach is a combination of the first two. Separate collection containers for paper are provided to individuals that produce large quantities of paper. Other individuals with lower production volumes would be able to use the centrally located collection containers. In most offices the third approach should prove to be the most efficient.

The paper collected within the individual offices must be accumulated into a marketable quantity. The simplest and most expedient method would be to modify the existing janitorial contract to have the contractor collect all the paper and deposit it into a primary accumulation container. Such collection could occur concurrently with the removal of general trash from the offices.

Not all office paper is appropriate for recycling. Confidential and higher security level papers will need to be separately burned or shredded, as currently practiced. There may also be some concerns about allowing "For Official Use Only" materials from leaving the base. These issues will have to be addressed by the security officers. Those papers that are not allowed to be recycled for security reasons can continue to be deposited in the general trash to be burned in the incinerator.

Markets have not been well developed for magazines at this time. The processing costs and concerns about the heavy metals and other pollutants within the inks used on magazines makes them poor candidates for recycling at this time.

VI.A.5 Plastics

The most promising market for recyclable plastics from the base is the Japanese lumber industry. Within the United States, the lumber industry buys mixed plastics to make a

substitute wood that can be used to make fences and other traditional wood products (Fearncombe, 1991). Given the limited wood resources available within Japan, the Japan lumber industry may be using mixed plastic for this same purpose.

Significant progress in plastic recycling within the United States was not made until the later 1980's. Although, the author is not familiar with the current level of plastic recycling in Japan, there was very little plastic recycling in Japan in 1986 (Hershkowitz and Salerni, 1987). Since, plastic recycling is concurrently developing in both countries the status in the United States will be used as a guideline for recommendations for plastic recycling at the base.

Plastic products are generally made from one of six different polymers as shown in Table IV. Most plastic recycling methods require the use of only one polymer. Impurities including presence of other polymers, debris, or other foreign materials will result in an unusable product. The two polymers that are currently recycled most are High Density Polyethylene (HDPE) and Polyethylene Terephthalate (PET). Within the United States, milk, water, juice, and non-carbonated drink bottles are almost exclusively made from HDPE and the clear portion of soft drink bottles are made from PET. The large quantities of these products available in the United States provides an adequate supply of empty containers which are relatively easy to segregate.

Traditionally milk and soft drinks have not been sold in plastic containers at the Yokosuka Navy Base's commissary and the exchange. Consequently there is very little of this easily segregated plastic present in the base's trash. Other bottles are made from these polymers and other recyclable polymers, but these other bottles are not as easily segregated. Many plastic packaging materials are now marked on the bottom with a Plastic Container Code as shown in Appendix J, but unless the plastics are source segregated it becomes a very tedious and costly job to segregate these containers. After the containers are

segregated they often must be processed to remove labels, adhesive, and product residue before they will be accepted by the recycler. These processing systems are costly and would not be cost effective for the relatively low volumes of refuse generated on the base. Typically a population of about one million people is required to make one of these facilities cost effective (Fearncombe, 1990).

TABLE IV PLASTIC PACKAGING MATERIAL SUMMARY

Plastic	General Description and Usage	Primary Markets	Disposable Consumer Packaging
Low Density Polyethylene (LDPE)	Soft, flexible, clear or pigmented, good vapor barrier; predominately film for food, retail & industrial pkg; other major uses are paper coatings, a wide variety of household items, & wire and cable covering	Packaging Housewares Electronics	Films for food packaging, trash bags, grocery sacks retail bags, garment bags, coatings on paperboard, containers & boxes, newspaper wrapping, & diaper liner
High Density Polyethylene (HDPE)	Translucent in natural form, tough, good chemical resistance; predominately blow molded into bottles & large parts (fuel tanks, drums, pails); other uses include pipe, containers, & high strength film	Packaging Building Housewares	Milk, water, juice, noncarbonated drink and pharmaceutical/cosmetic bottles, dairy tubs, household chemical bottles (bleach, detergent, cleaning products, antifreeze, oil, windshield washer fluids, etc.), & beverage bottle and base cups
Polystyrene (PS)	Clear or pigmented in rigid form; foamed or expanded to very light weight; varied uses including modeling kits, toys, food packaging, dinnerware, insulation products, & appliances	Packaging Electronics Building	Foam; single serving plates, cups, hinged containers, egg cartons, & food trays; Rigid: clear tumblers, glasses, cutlery, vending and portion cups, dairy containers, & cassettes
Polypropylene (PP)	Light weight, rigid, good barrier, & chemical resistance; major usage in synthetic fibers (carpet backing & facing yarn, geotextiles, & twines), caps & closures, snack food pkg film, car batteries, & variety of durable goods	Fibers Packaging Transportation	Caps & closures, snack & tobacco packaging films, small food containers (margarine & yogurt tubs, microwave only baking containers, single serving fruit sauces, etc), straws, & contact clear food bottles (syrup, ketchup, barbecue, jams/jellies, salad salad dressing, etc.)

TABLE IV PLASTIC PACKAGING MATERIAL SUMMARY (continued)

Plastic	General Description and Usage	Primary Markets	Disposable Consumer Packaging
Polyethylene Terephthalate (PET)	Clear, shatter-proof, and stiff material; predominately a synthetic fiber (polyester for apparel and carpeting), also used for food and soda bottles, x-ray & video tape film	Fibers Packaging	Clear portion of soft drink bottle, liquor, sparkling water, spice, mouthwash, edible oil, salad dressing, and barbecue sauce bottles, & dual ovenable food trays
Polyvinyl Chloride (PVC)	Clear or pigmented, high gloss, good chemical resistance, self-extinguishing; predominately used in buildings (pipe, siding, windows, flooring), other uses including bottles, blister packs, pkg films, & wire & cable covering	Building Packaging Electronics	Clear bottles: edible oils and vinegar, mouthwash, toiletries, & cleansers; Glossy bottles: motor fluids, toiletries, and cleansers; Films: meat and produce wrapping; Sheet: blister packaging

Source: (Fearncombe, 1990)

Therefore, the best market for recycled plastics is the lumber industry. If this type of market is available, it is recommended that a source segregation depository located near the commissary be used. Plastics are very bulky, thus they would have to be compacted or at least shredded prior to being hauled off the base. Since the incinerator's compactor is not expected to be repaired, currently the base is limited to shredding only.

VI.A.6. Yard Waste Management

Yard waste can be a significant contributor to the waste stream providing up to 50% of the residential waste stream in a typical U.S. suburb during summer and fall months. Since off-base residents and on-base tower and apartment residents contribute very little yard wastes, this figure would be less for the Yokosuka Base. But when considering the yard waste from the public areas, yard waste is a very significant contributor to the refuse handling and disposal problem. In addition, since yard waste is high in moisture content, large quantities of yard waste makes it more difficult to maintain a quality flame within the combustor. Thus, yard waste management warrants consideration when looking at the overall waste management at the Yokosuka Naval Base.

Currently the housing office does recommend to the residents that they can usually leave their grass trimmings on the lawn if they cut the lawn every week. This recommendation does not go far enough to promote proper yard waste management. A few recommendations to improve yard waste management on the Yokosuka Base are presented below:

Yard waste reuse can include leaving the trimmings on the yard or making compost from the trimmings. Compost is the controlled decomposition of organic materials using aerobic bacteria. Composting reduces the material volume by 70 - 80 % (Appendix K). The compost can be spread over existing lawns or incorporated into the soil to provide organic matter in a usable form. An effective yard waste management program involves both leaving the grass trimming in place and composting.

Yard waste management education should go beyond a suggestion in the housing guide. The recommendation is that educational pamphlets such as "A Homeowner's Guide to Recycling Yard Wastes" published by the Illinois Department of Energy and Natural Resources (Appendix K) be made available to the housing residents through the housing office. This pamphlet could be the basis of a class offered by the housing office or the Family Support Center.

Education for the residents will accomplish little, if the materials and services to practice yard waste recycling are not available. Materials to construct composting bins, forks to handle the compost and mower blade sharpening services are essential for a good yard waste recycling program. A possible source for composting bin materials would be the wooden pallets that NSD is now paying to dispose of. Four pallets fastened together with or without a wire mesh lining would form good composting bins. If this arrangement is too unsightly, the composting bin can be surrounded by a picket or wooden fence to enhance the yards aesthetics. Appendix K provides examples of other composting bin designs that may be used.

If this type of composting program is to be undertaken it is recommended that the

base construct model compost bins to prove their benefit prior to publicly implementing the program. The experimental models can be used as examples for the personnel wishing to build their own composting bins. Materials should be provided to the residents at minimal costs to promote maximum cooperation. One option would be to provide composting bin materials to the residents free in order to reduce the quantities of refuse collected and burned. The savings due to reduced volumes could be used to offset the costs of the compost bin materials. If the materials cannot be provided free then they should be provided at a reasonable cost at the Exchange.

A sharp mower blade (a mulching mower is not necessary) and frequent mowing will mean finer clippings that will decompose quickly. To assist residents in maintaining sharp mower blades PWC could provide a mower blade sharpening service much like the air conditioner installation service currently provided to the housing residents at a reasonable charge.

VI.A.4.b. Public Area Yard Waste Reuse

A large composting facility that would accept all the base's yard waste would require a significant quantity of land located where it would not be a nuisance to base personnel or cause ecological concerns. Unfortunately land meeting these requirements is not available. The recommended approach to managing the yard waste from the public areas would be to require the contractor to use mulching mowers where possible and leave the grass residue on the lawns. Branches and twigs can be chipped and placed around trees and shrubs or used to make long lasting walking paths.

The best solution for leaves is to compost them, but space may not be available to

establish adequate composting facilities. If they cannot be composted, then the base has no choice but to continue to burn them.

B. Operational Changes

The most significant operational change that can be made is to eliminate the use of Tesisorb, as recommended by Mr. Jeffrey Machusak of Research Cottrell. The changes described here are the result of a phone conversation with Mr. Machusak. The file and thus the details of these recommendations were sent to research Cottrell Japan, 1-31 Toyotsu-cho, Suita City, Japan; phone number is 063-30-5233 in Japan. Because the required emission levels are not severely restrictive, Mr. Machusak believes that Tesisorb can be eliminated by increasing the amount of lime used. The lime would be increased to a level of about 15-20 % solids in the tank. The actual level would be determined by using trial and error. The cost savings on the Tesisorb will more than offset the additional cost for the lime.

An option that will limit the amount of lime required is to decouple the temperature control from the lime slurry injection rate. This could be done by using 20% solids in the tank to feed the existing spray nozzles. The lime slurry flow rate would be changed to where it is controlled by the SO₂ and HCl emission rates, assuming the monitoring equipment provides reliable data. Only enough lime slurry would be injected to meet required emission levels. This not only will limit the amount of lime used but will also reduce the amount of ash collected on the filters.

Additional spray nozzles may be used to inject water to control the inlet temperature to the baghouse or the additional water requirements may be injected into the slurry before it enters the quencher.

Additional savings may be realized by considering recycling the lime from the fabric filter. After the above changes are made it is recommended that the flyash collected on the filters be tested for unreacted lime. If 20% or more of the lime is unreacted, then it may be economical to recycle the lime by using the flyash in the slurry.

PWC should check with the City of Yokosuka to determine if any additional test will be required when making the suggested changes. The City may require that the system be retested as it was at start-up or they may rely on the continuous monitoring system to ensure that the system continues to meet regulations.

C. Burning More Wood and Plastics

After these changes are made to reduce the cost of operating the incinerator, then PWC can consider increasing the amount of plastics and wood that is burned in the incinerator. If the lime slurry control is to be based upon the SO₂ and HCl emission levels then additional plastics and wood can be added until the system is no longer able to meet HCl and SO₂ emission requirements by increasing the amount of lime injected into the system.

Additionally NO_x emission levels must be monitored. Thus, the level at which plastics and wood can be burned in the incinerator can be best determined by trial and error. The plastics and wood can be increased until one of the regulated emission levels is exceeded, then reduce the quantity of plastic and wood that is combusted until all emission levels are met.

When burning more plastics and wood the temperature in the combustion chamber will tend to increase. This will require that the operators monitor the temperature much closer and possibly increase the ratio of air injected by the temperature control fan to that injected

to the stokers. There was a clear reluctance on the part of the operators to do this.

The plastics should be shredded and well mixed with the other refuse to reduce the formation clinkers and to average the heat value of the fuel.

An economical analysis of whether to burn additional plastics and wood should also be performed. Currently PWC is not sending more than 9500 metric tons per year to the City of Yokosuka landfill; thus, the savings due to burning more plastics may be limited to transportation costs. This savings may be offset by having to use and dispose of more lime and lime reaction end products, respectively. If PWC should have to pay additional disposal fees due to exceeding the 9500 metric ton per year limit or the agreement being changed with the City of Yokosuka, then a new economical analysis should be done as the conditions change.

Wood seems to be the best choice for increasing combustion levels. Since the wood shredder does not seem to be operated constantly for eight hours per day as required by contract, there seems to be a potential for increasing the amount of wood burned. If additional wood is burned then this would directly offset disposal fees currently being paid by NSD.

D. Future Studies

The current operations do not seem to use personnel effectively. An example is that there are two crane operators, but only one crane. Obviously more than one person must be able to operate the crane, but with current arrangements on most days one crane operator runs the crane and the other operator sits at a table. The crane operators are not required to do anything else because "its not in their job description". There also seems to be more

operators than required. Because of the excess staff on many days when there is only enough refuse to operate one incinerator, both are operated for only a short period. An option would be to get the operators more involved with the maintenance of the facility and reduce the maintenance contractor's requirements.

VI Conclusions

The Public Works Center (PWC) incinerator is operating within the U.S. and Japanese regulations. Financially there is little incentive for PWC to burn additional plastic. PWC is allowed to dispose up to 9500 metric tons per year of refuse in Yokosuka City's landfill without additional disposal fees; currently PWC disposes about 6500 metric tons of refuse per year in the landfill. However, technically PWC should be able to burn additional plastics if they so choose and still meet operational and emission limits. Before additional plastics are burned it is recommended that PWC implement cost saving measures recommended in this report.

The most significant cost savings can be obtained by eliminating the use of Tesisorb. The use of Tesisorb in Japan is very costly due to material costs. The emission levels should be met without further use of Tesisorb. Elimination of Tesisorb will likely require the use of additional lime. The amount can be determined by trial and error or the lime slurry injection can be regulated by the emission levels by making some minor modifications to the quencher and the control systems. If no additional lime is required, the annual savings would be \$111,375. If the lime requirement doubles, the annual savings would be \$76,519.

Increasing the amount of wood burned in the incinerator would not decrease the amount of refuse sent to the landfill, but would decrease the cost of disposing wood by other

means. The Naval Supply Depot currently pays a contractor to remove pallets from the base. Since there is no immediate need to decrease the amount of refuse sent to the landfill, additional wood should be burned before additional plastic is burned. The incinerator should be able to burn additional wood and remain within operational and emission limits; although temperature control may be more difficult.

There is potential to reduce the quantities of refuse burned by the incinerator by recycling paper, eliminating waste brought on base by off-base residents, and composting yard wastes. An intense educational program will be required to implement these waste and cost reduction programs.

REFERENCES

- Fearncombe, J. (1991) Guide for Recyclers of Plastic Packaging in Illinois, Bottom Line Consulting for Illinois Department of Energy and Natural Resources Office of Solid Waste and Renewable Resources, Springfield, IL
- Flagan, R. C. and Seinfeld, J. H. (1988) Fundamentals of Air Pollution Engineering, Prentice-Hall, Englewood Cliffs, New Jersey
- Hershkowitz, A. and Salerni, E. (1987) Garbage Management in Japan Leading the Way, Inform, New York, NY
- Hootman, H. A. and Vernet, J. E. (1991) Air Toxins Provisions of the Clean Air Act: Potential Impacts on Energy Report No. ANL/EAIS/TM-66
- Japan Environment Management Center (1988) Initial Stack Emissions Test
- Rood, M. J. (1988) Technical and Economic Evaluation of Municipal Solid Waste Incineration, Office of Technology Transfer (OTT), University of Illinois Center for Solid Waste Management and Research.
- Simek, R. E. and Rood, M. J. (1990) Combustion of municipal solid waste: influence of recycling on emissions of air contaminants and power generation, Masters Thesis, Dept. of Civil Engineering, University of Illinois at Urbana-Champaign
- Teller, A. J., Dr. (1991) Designing systems to meet the air emission control challenge, Solid Waste and Power vol. V, no. 6: 12-16
- Tillman, D. A., Rossi, A. J., and Vick, K. M. (1989) Incineration of Municipal and Hazardous Solid Wastes, Academic Press, San Diego, CA

APPENDIX A
Start-up Procedures

APPENDIX A

MUNICIPAL SOLID WASTE INCINERATOR START-UP PROCEDURES

1. Ensure all charts are operating (operators should also ensure that the charts are synchronized with the actual time)
2. Turn Damper Control Switch On
3. Turn Negative Pressure Control to Manual
4. Close Dampers
5. Start Induced Draft Fan
6. Turn on all system switches
 - a. Stoker Hydraulic Unit
 - b. Ash Conveyer
 - c. Cooling Chamber Control Device
 - d. Gas Temperature Control at Quencher Outlet
 - e. Pre-heater Dust Conveyer
 - f. Pre-heater Dust Damper
 - g. Quencher Equipment: Rotary Valves and Dust Conveyer
 - h. Purge Blower
 - i. Slurry Compressor (Turned on by machinery operator on the machinery floor)
7. The operator notifies the crane operator to charge the refuse hopper
8. If the incinerator has been down for a sufficient time for the coals to cool or if the refuse is very wet, then the auxiliary burner is inserted into the incinerator
9. When the refuse hopper is filled(as indicated on the T.V. screen, the operator starts the stokers
10. The operator watches the negative pressure within the incinerator. When the negative pressure reaches approximately 2-3 mm of water the negative pressure controller is

switched to automatic

11. The operator monitors the flame development and temperatures as the incinerator warms up. The operator gradually transitions the damper settings from start-up to operator settings
12. Once the gas temperature at the inlet of the baghouse reaches 150°C the $\text{Ca}(\text{OH})_2$ and Tesisorb injection systems are started

APPENDIX B

Sample Emission Charts

NO_x and SO₂ Chart

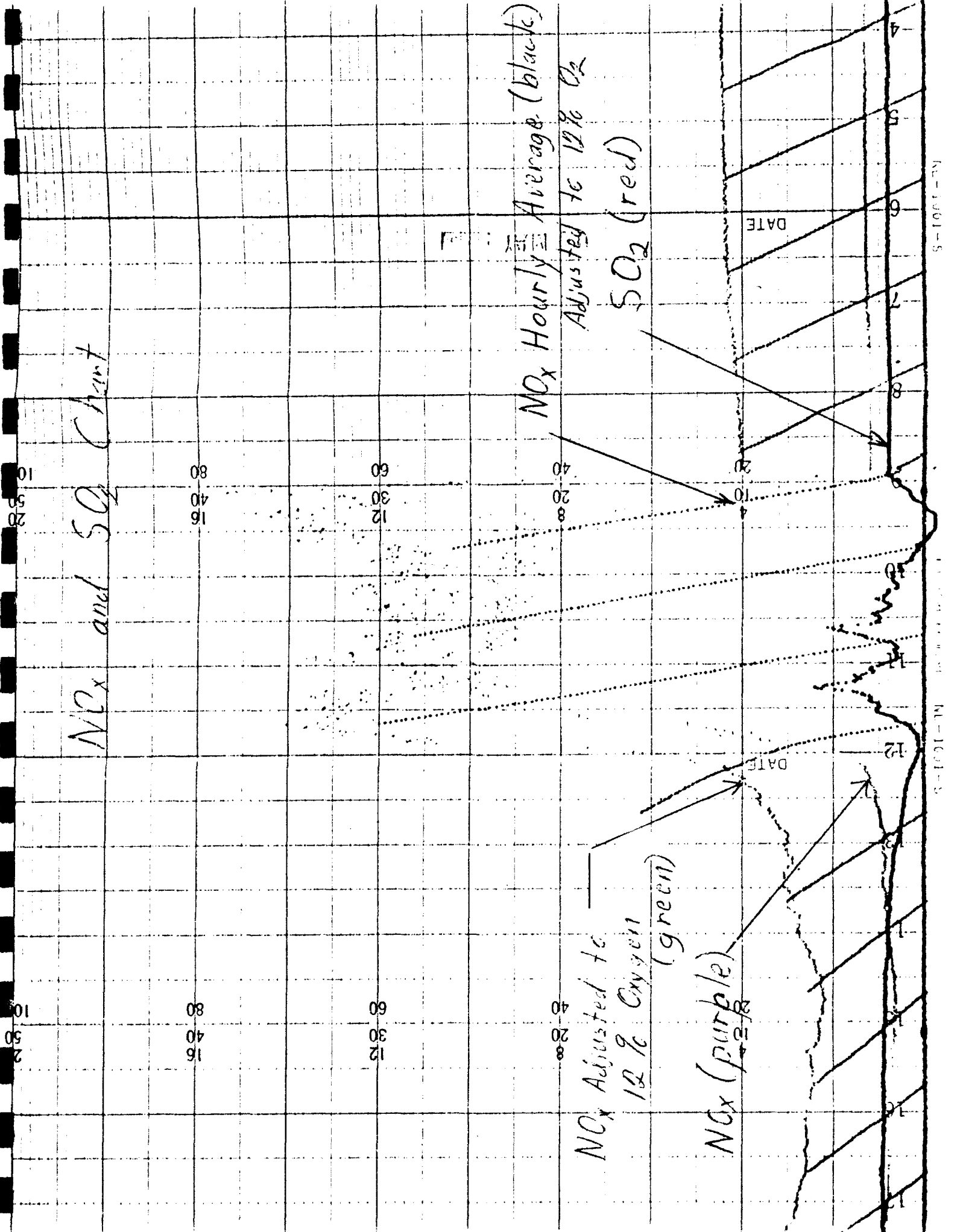

NO_x Hourly Average (black)
Adjusted to 12% O₂

SO₂ (red)

NO_x Adjusted to
12% Oxygen
(green)

NO_x (purple)

DATE

DATE

HCl and Oxygen Chart

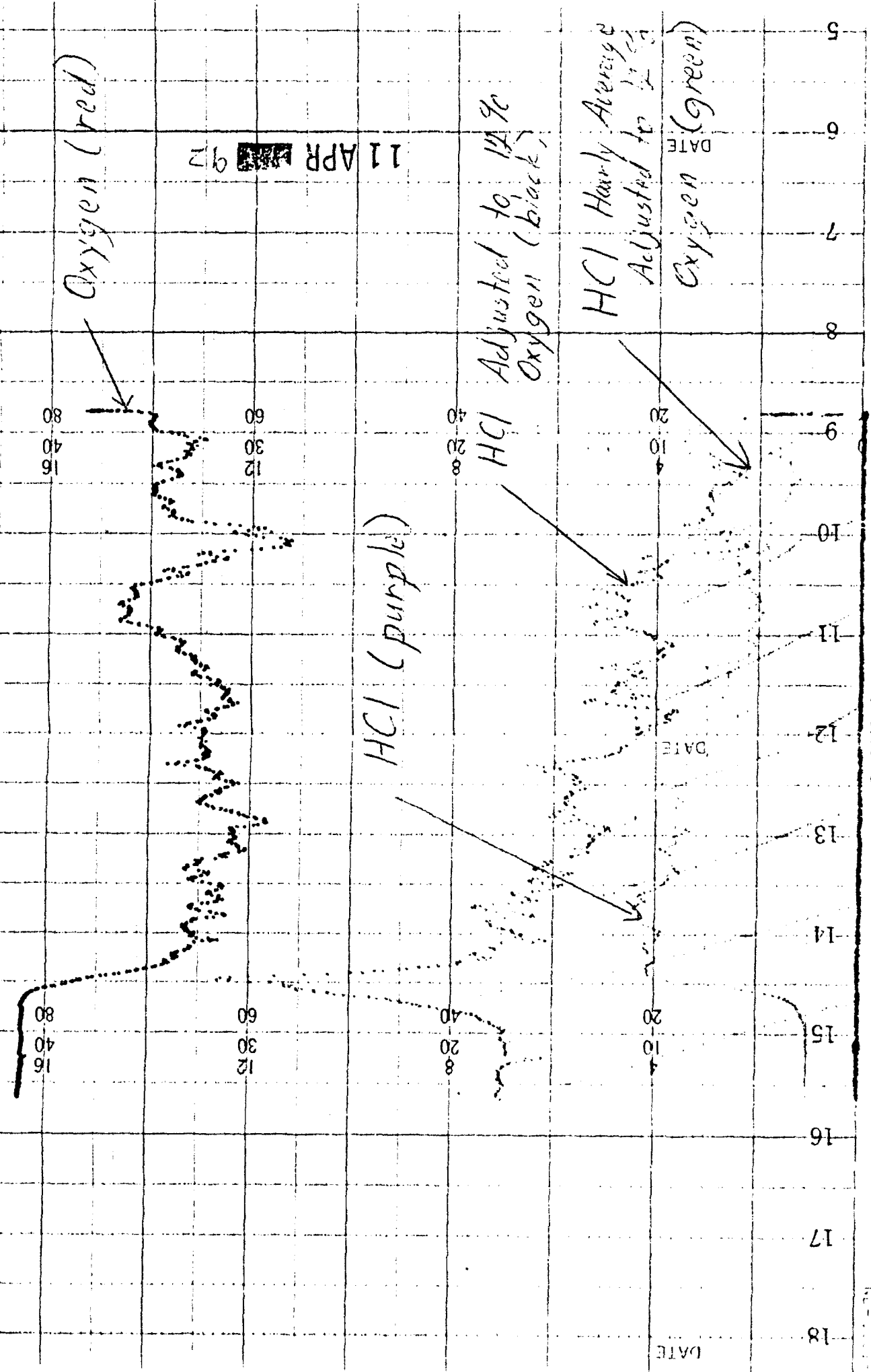

APPENDIX C

Refuse Residence Time Calculations

APPENDIX C

REFUSE RESIDENCE TIME CALCULATIONS

Wet Refuse:

- Feeder: The refuse is pushed once every 600 seconds.
- Drying Stoker: 1 push 100 - 250 seconds, 6 pushes to cross drying stoker.
Crossing time is from 600 - 1500 seconds.
- Burning Stoker: 1 push 80 - 100 seconds, 6 pushes to cross burning stoker.
Crossing time is from 480 - 600 seconds.
- Burn-out Door: Opens every 150 seconds.

Wet Refuse Residence Time:

- Drying Stoker: 600 - 1500 seconds, or 10 - 25 minutes
- Burning Stoker: 480 - 600 seconds, or 8 - 10 minutes
- Burn-out: 0 - 150 seconds, or 0 to 2.5 minutes
- Total Combustor
Residence Time: 18 - 37.5 minutes

Dry Refuse:

- Feeder: The refuse is pushed once every 450 seconds.
- Drying Stoker: 1 push 80 - 150 seconds, 6 pushes to cross drying stoker.
Crossing time is from 480 - 900 seconds.
- Burning Stoker: 1 push 30 - 80 seconds, 6 pushes to cross burning stoker.
Crossing time is from 180 - 480 seconds.
- Burn-out Door: Opens every 90 seconds.

Wet Refuse Residence Time:

- Drying Stoker: 480 - 900 seconds, or 8 - 15 minutes
- Burning Stoker: 180 - 480 seconds, or 3 - 8 minutes
- Burn-out: 0 - 90 seconds, or 0 to 1.5 minutes
- Total Combustor
Residence Time: 11 - 24.5 minutes

APPENDIX D

Sorted Analysis of the Municipal Waste

Appendix D
SORTED WASTE ANALYSIS FOR PWC MWI

Non-Segragated Refuse(Estimated by Navy Civil Engineer Laboratory, 1985):

<u>Sorted Item</u>	<u>Weight %</u>	<u>Btu/lb Energy Content</u>	<u>Btu/lb Energy in Mix</u>
Paper/Cardboard	15.5	7,500	1,160
Wood	32.0	10,000	3,900
Food/Garbage/Yard	8.7	6,750	600
Glass	3.4	-	-
Plastics	14.7	14,000	2,060
Rubber	2.9	10,000	290
Textile	2.9	8,300	240
Metal	9.5	-	-
Others (Ash)	2.9	-	-
Tires	0.5	-	-
	-----		-----
	100.0		8,250

Estimated Segregation and Impact:

Data from PWC:

<u>Fiscal Year</u>	<u>Refuse Collected Metric Tons</u>	<u>Refuse Combusted Metric Tons</u>	<u>Non-combustible Refuse Metric Tons</u>	<u>Contractor Removed Metric Tons</u>
90	17,194	5,567	6,811	4,816
91	18,542	5,215	5,037	8,290
92 (3 months)	4,420	1,982	997	1,441

These figures indicate that a very small percentage of the refuse collected is incinerated. The percent combusted for the above periods range from 28 percent in FY 91 to 45 percent in FY 92. The segregation analysis will be based upon the most recent 45 percent combustion rate in FY 92.

<u>Sorted Item</u>	<u>Estimated % Removed</u>	<u>Combusted Waste per 100 kg Waste</u>	<u>Segragated Sorted Analysis</u>
Paper/Cardboard	30	15.5(.70) = 10.85	24.07
Wood	65	39(.35) = 13.65	30.29
Food/Garbage/Yard	0	8.7(1.00) = 8.7	19.30
Glass	70	3.4(.30) = 1.02	2.26
Plastic	80	14.7(.20) = 2.94	6.52
Rubber	50	2.9(.50) = 1.45	3.22
Textile	10	2.9(.90) = 2.61	5.79
Metal	90	9.5(.10) = .95	2.11
Others	0	2.9(1.00) = 2.90	6.44
		-----	-----
		45.07 kg	100.00

APPENDIX E

Model of Municipal Waste Incinerator Results

Sorted Analysis of Waste

Sorted Item	%mass	%C	%H	%O	%Cl	%S	%N	%H2O	%ASH
MIXED PAPERS	24.1	35.50	4.75	32.71	.2	.20	.13	21.8	4.79
MIXED PLASTICS	6.5	56.43	7.79	8.05	3.0	.29	.85	15.0	8.59
LEATHER & RUBBER	3.2	43.09	5.37	11.57	5.0	1.17	1.34	10.0	22.49
TEXTILES	5.8	37.23	5.02	27.11	.3	.28	3.11	25.0	1.98
WOOD	30.3	41.20	5.03	34.55	.1	.07	.24	16.0	2.82
FOOD WASTES	10.0	17.93	2.55	12.85	.4	.06	1.13	60.0	5.10
YARD WASTES	9.3	23.29	2.93	17.54	.1	.15	.89	45.0	10.07
GLASS	2.3	.51	.07	.35	.0	.00	.03	2.0	97.04
METAL	2.1	4.41	.59	4.21	.0	.01	.05	2.0	88.73
FINES, ≤1"	6.4	15.03	1.91	12.15	.4	.15	.50	25.0	44.90

Ultimate Analysis and Mass Feed Rates of Waste

Component	lbm/hr	mass%	lbmole/100lbm	mole%
CARBON	2590.37	33.28	2.77	27.67
HYDROGEN	334.94	4.30	4.27	42.64
OXYGEN	1914.94	24.60	1.54	15.36
CHLORINE	39.91	.51	.01	.14
SULFUR	13.39	.17	.01	.05
NITROGEN	47.66	.61	.04	.44
WATER	1923.55	24.71	1.37	13.70
ASH**	919.24	11.81	—	—
TOTAL	7784.00	100.00	10.01	100.00

Incinerator Flue Gas Composition

Component	lbm/100lbm(w)	mass%	lbmole/100lbm(w)	mole%
CARBON DIOXIDE	121.98	16.91291	2.62	11.00562
WATER (g)	63.07	8.74540	3.30	13.89865
NITROGEN	486.14	67.40601	16.38	68.91807
OXYGEN	49.15	6.81483	1.45	6.09892
HYDROGEN CHLORIDE	.53	.07313	.01	.05744
SULFUR DIOXIDE	.34	.04741	.01	.02119
SULFUR TRIOXIDE	.00	.00031	.00	.00011
TOTAL	721.21	100.00000	23.76	100.00000

Incinerator Flue Gas Data

Mass emission rate, lbm/hr	56205.3
Volumetric flow rate, acfm	68073.8
Volumetric flow rate, scfm (77°F)	12087.5
Volumetric flow rate, dscfm (77°F)	10407.5
Molar flow rate, lbmole/hr	1849.6
Average molecular weight, lbm/lbmole	30.4
Adiabatic flame temperature, °F	2564.6
Combustion air temperature, °F	77.0
Excess combustion air, %	50.0

Incinerator Emission Concentrations

Oxygen concentration, % dry	7.1
Carbon dioxide concentration, % dry	12.8
Sulfur dioxide concentration, ppm _{dv} (@12% CO ₂)	231.1
Sulfur dioxide emission rate, lbm/hr	55.4
Sulfur trioxide concentration, ppm _{dv} (@12% CO ₂)	1.2
Sulfur trioxide emission rate, lbm/hr4
Sulfur retention in bottom ash, % by mass0
Chlorine concentration, ppm _{dv} (@12% CO ₂)0
Chlorine mass emission rate, lbm/hr0
Hydrogen chloride concentration, ppm _{dv} (@12% CO ₂)	626.4
Hydrogen chloride mass emission rate, lbm/hr	85.4
Particulate loading, gr/acf11
Particulate loading, gr/dscf (@12% CO ₂)70
Particulate loading, mg/Nm ³ (@12% CO ₂)	1747.2
Particulate material mass emission rate, lbm/hr	66.55

Preliminary Incinerator Design Data

Type of incinerator	Mass burn, refractory
Particulate mass emission factor, lbm/ton	17.10
Heat generation rate, Btu/hr	41925410.00
Heat release rate, Btu/cft-hr	25000.00
Total heat input, Btu/lbm	5386.10
Heat loss, % of total heat input00
Volume, cu ft	1677.02
Diameter, ft	8.93
Length, ft	26.79
Length-to-diameter ratio	3.00
Superficial gas velocity, ft/sec	18.12
Gas residence time, sec	1.48

Lower and Higher Heating Value of the Municipal Solid Waste

Lower heating value, Btu/lbm ("as received")	5386.
Lower heating value, Btu/lbm (moisture free)	7155.
Lower heating value, Btu/lbm (moisture & ash free)	8485.
Higher heating value, Btu/lbm ("as received")	6049.
Higher heating value, Btu/lbm (moisture free)	8035.
Higher heating value, Btu/lbm (moisture & ash free)	9529.

APPENDIX F

Proper Emission Reporting Procedures

10 522

10 522

NO_x and SO₂ Chart

80
40
15

80
40
15

Number to report for HCE

80
30
15

80
30
15

Value to report for CMC

NO_x Hourly Average (black)
Adjusted to 12% O₂

NO_x Adjusted to 12% Oxygen (green)

NO_x (purple)

SO₂ (red)

DATE

DATE

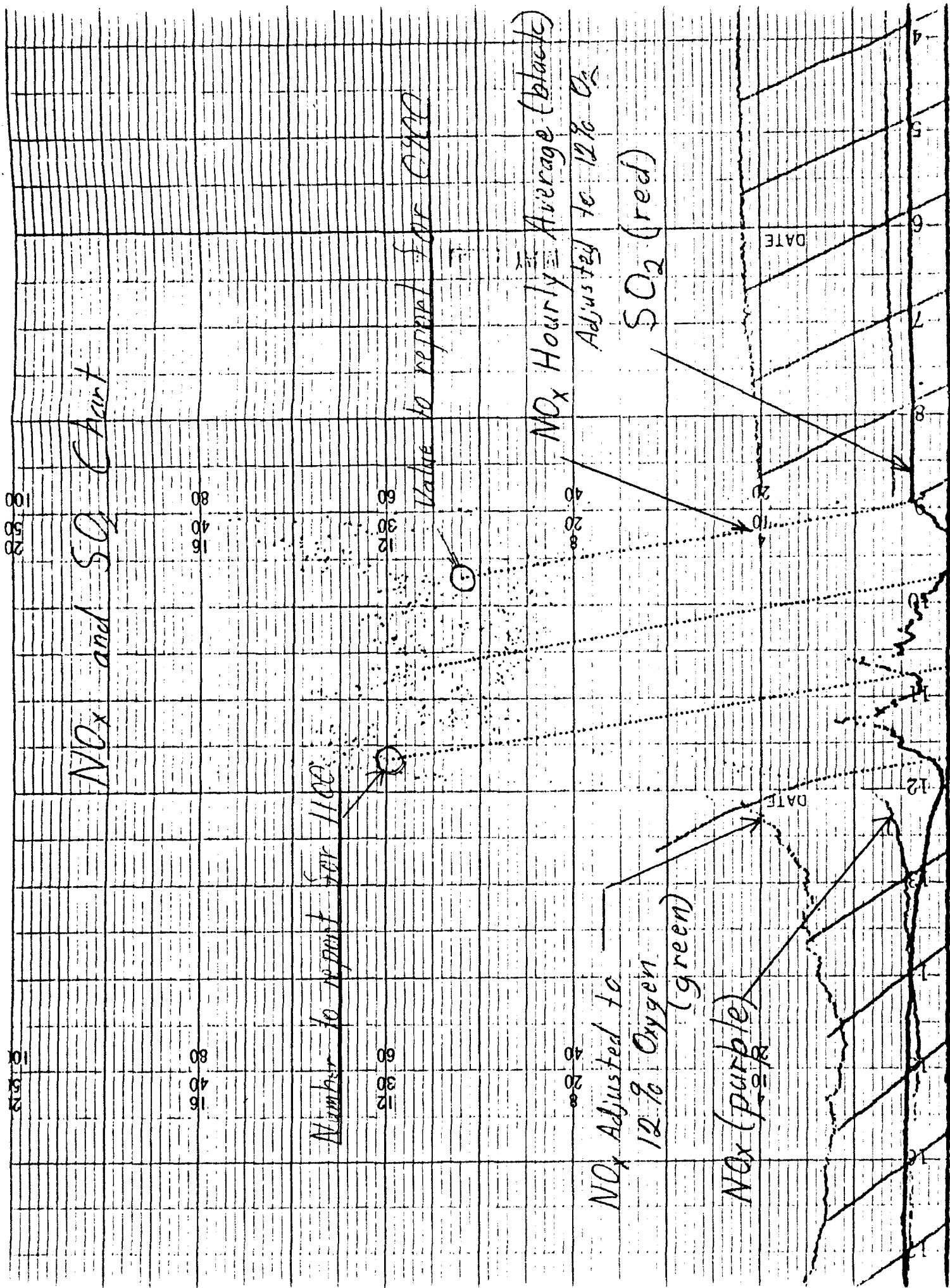

APPENDIX G

Tesisorb Specifications

REQUEST ESTABLISH IDIC FOR PURCHASE CHEMICALS.

ITEM No.	ITEM DESCRIPTION	U/I	TOTAL REQUIREMENT IN ONE YEAR	U/P	AMOUNT
1.	N/A (LOCAL) MSDS #2299 NFPA 1-0-0 CALCIUM HYDROXIDE POWDER. COMPOSITION: a. CALCIUM HYDROXIDE >72.5% b. IMPURITIES < 3.0% c. CARBON DIOXIDE < 1.5% PARTICLE SIZE DISTRIBUTION a. 590 micron 0.0% b. 149 micron 0.0% c. 74 micron < 0.2% d. 44 micron < 2.0% MFC: RYOKOH SEKKAI KOGYO Co., LTD.	KG	240,000 Kg	¥32.5	¥7,300,000-
2.	N/A (LOCAL) MSDS #1265 NFPA 1-0-0 SPECIAL CATALYST. COMPOSITION: a. SILICA 75% b. ALUMINA 15.3% c. CALCIUM OXIDE 0.1% d. FERRICE OXIDE 0.9% e. SODIUM OXIDE 3.5% f. POTASSIUM OXIDE 4.0% GRAVITY: 0.65 - 1.0 MESH: 200 - 325 MESH	KG	240,000 Kg	¥165	¥39,600,000-

JUSTIFICATION: a. These chemicals are indispensable for the EXHAUST-GAS POLLUTION CONTROL SYSTEM in BLDG 1829 SOLID WASTE DISPOSAL PLANT.
b. Gain of refuse amount (redouble over last year) and operating hours.

¥47,300,000-

PRODUCED AT GOVERNMENT EXPENSE

THE QUANTITY OF CHEMICALS CONSUMPTION

CONSUMPTION AT THE UNTIL NOV 1991. (In case of one FURNACE operated)

- FEEDERS rpm of CALCIUM HYDROXIDE POWDER.....30 rpm
- CONSUMPTION of CALCIUM HYDROXIDE POWDER.....about 1.1 Kg/m = 66 Kg/h
- CONSUMPTION of day.....66 Kg/h X 6.5 hours = 429 Kg/day
- CONSUMPTION of month...429 Kg X 25 operated days = 10,725 Kg/month
- FEEDERS rpm of SPECIAL CATALYST POWDER.....30 rpm
- CONSUMPTION of SPECIAL CATALYST POWDER.....about 0.6 Kg/m = 36 Kg/h
- CONSUMPTION of day.....36 Kg/h X 7.5 hours = 270 Kg/day
- CONSUMPTION of month...270 Kg X 25 operated days = 6,750 Kg/month

NOTE : In this case are not obtain a good result for EXHAUST GAS POLLUTION CONTROL.

Reason, not enough is blow quantity.

CONSUMPTION AT THE PRESENT TIME. (In case of one FURNACE operated)

- FEEDERS rpm of CALCIUM HYDROXIDE POWDER.....40rpm
- CONSUMPTION of CALCIUM HYDROXIDE POWDER.....about 1.5 Kg/m = 90 Kg/h
- CONSUMPTION of day.....90 Kg/h X 7.0 hours = 630 Kg/day
- CONSUMPTION of month...630 Kg X 25 operated days = 15,750 Kg/month
- FEEDERS rpm of SPECIAL CATALYST POWDER.....50 rpm
- CONSUMPTION of SPECIAL CATALYST POWDER.....about 1.2 Kg/m = 72 Kg/h
- CONSUMPTION of day.....72 Kg/h X 8.5 hours = 612 Kg/day
- CONSUMPTION of month...612 Kg X 25 operated days = 15,300 Kg/month

NOTE: In this case are obtain a good result for EXHAUST GAS POLLUTION CONTROL.

MINIMUM ORDER QTY FOR ONE DELIVERY ORDER : 8,000 kg

MAXIMUM ORDER QTY FOR ONE DELIVERY ORDER : 10,000 kg

DELIVERY REQUIREMENTS : 4 Days

DELIVERY POINT : BLDG 1829 SOLID WASTE DISPOSAL PLANT CODE 252, PWC.

BREAK DOWN OF REQUIREMENT BY MONTH

OCT	FY 93	20,000 kg
NOV		20,000 kg
DEC		20,000 kg
JAN		20,000 kg
FEB		20,000 kg
MAR		20,000 kg
APR		20,000 kg
MAY		20,000 kg
JUN		20,000 kg
JUL		20,000 kg
AUG		20,000 kg
SEP		20,000 kg

CODE 252 SOLID WASTE DISPOSAL DIVISION MANAGER
WAKABAYASHI YOSHIOKI *for Mr. Y. Yoshio*

PRODUCED AT GOVERNMENT EXPENSE

2 times/month

6/4/1992

WAKABAYASHI
YOSHIOKI

APPENDIX H

Pollution Control Flow Chart

FLOW-CHART OF EXHAUST-GAS POLLUTION CONTROL

A. GENERATION OF EXHAUST-GAS TO POLLUTION CONTROL STEP 3 FINAL

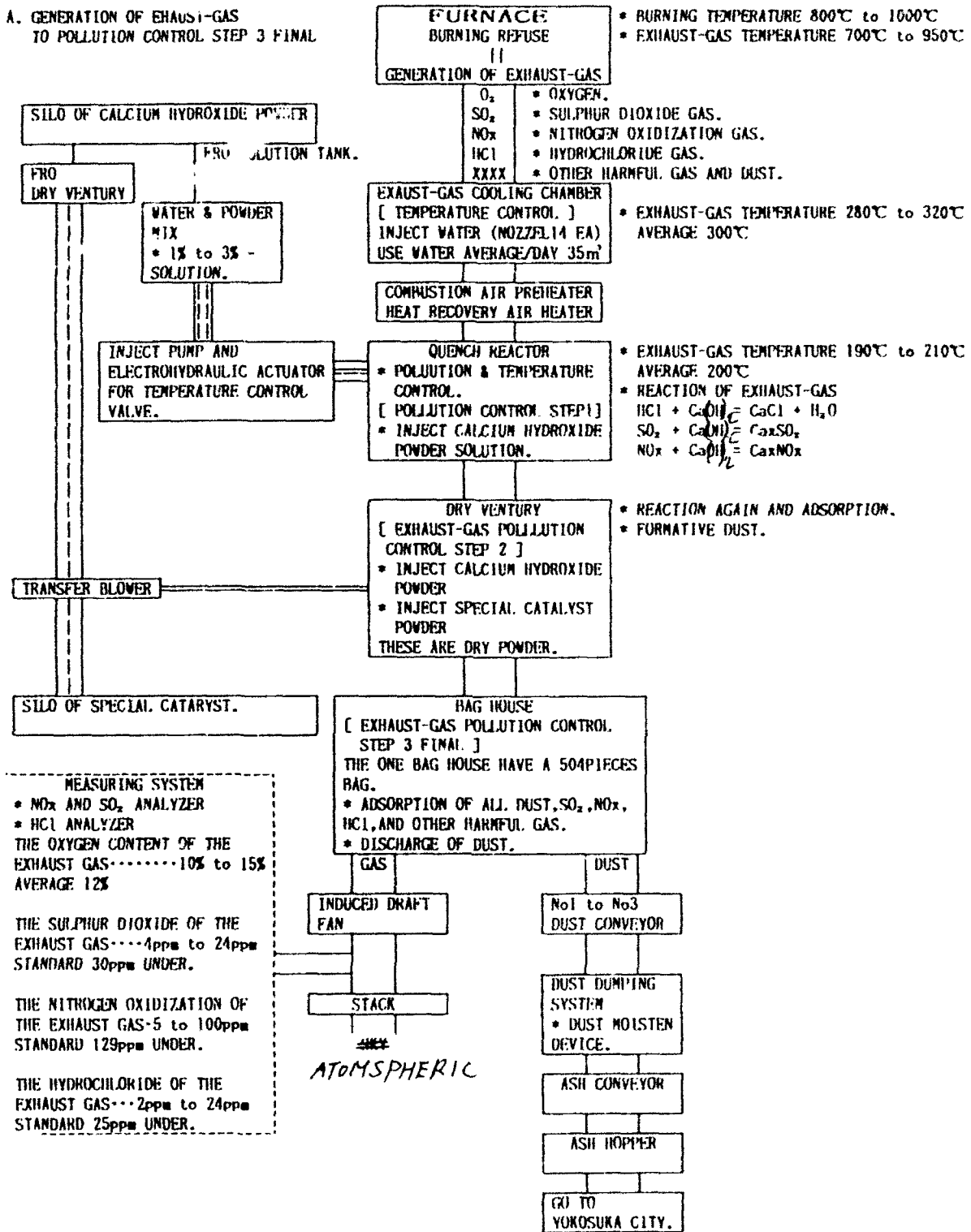

FLOW -- CHART OF WASTE

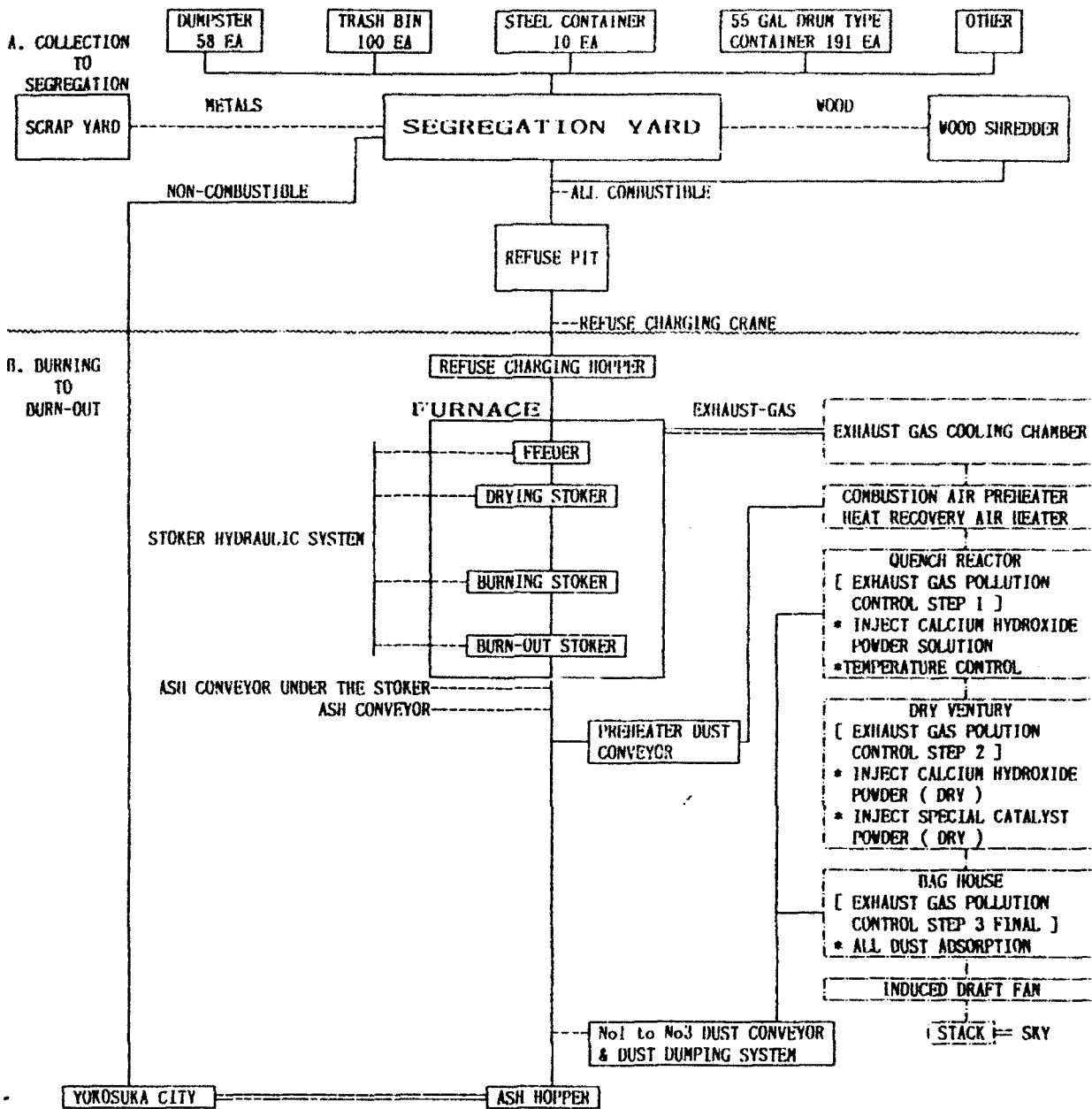

DESCRIPTION

a. COLLECTED WASTE	---	17,193 ton (FY 90 1 OCT 1989 to 30 SEP 1990)
		18,542 ton (FY 91 1 OCT 1990 to 30 SEP 1991)
		4,420 ton (FY 92 1 OCT 1991 to 31 DEC 1991)
b. BURNED	5,567 ton (FY 90)
		5,215 ton (FY 91)
		1,981 Ton (FY 92)
c. OPERATOR	OVER HEAD----- 1
		H/T HEAT PLANT OPERATOR- 7 (INC FA 2)
		L/P BOILER OPERATOR----- 2
		CRANE OPERATOR----- 2
		TOTAL----- 12
		APPLIED RATE: N/A \$22.44/hour

APPENDIX I

Sample Collection Containers



Shamrock Industries Incorporated • 834 North 7th St., Minneapolis, Minnesota 55411-4394 U.S.A.
Telephone 612-332-2100, TWX 910-576-2868 LDI NEHO • Facsimile 612-332-2100 ext. 552 or 612-536-6685 (24 hours)

Thank you for your interest in Shamrock's complete line of curbside recycling containers. Shamrock has been meeting the recycling needs of cities, counties, and haulers all across America and we want to help you get the recycling container best suited for your needs. Our curbside recycling container line includes:

- 1) RC2000 - The ultimate in curbside containers featuring optional lid and wheels and a 23.5 gallon capacity for future growth. It is designed to fully contain three grocery bags full of recyclables in a source separated environment, or can be used in semi-commingled and commingled programs. Its attractiveness and lid encourage kitchen placement where the whole process begins.
- 2) STACKABLE I & STACKABLE II - The solid wall construction prevents litter and makes cleaning the container easier. The Stackable I includes up to 50% post-consumer recycled materials and the Stackable II is a proprietary blend of 100% post-consumer recycled materials (50% milk bottles and 50% reground tires).
- 3) THREE-BAGGER - Heavy duty 21 gallon container for commingled materials or source separated using three standard grocery bags.
- 4) ONE-STEP RECYCLER - 7, 14, and 26 gallon containers for commingled programs. All feature optional lids and locking handles and are aesthetically pleasing, encouraging the convenience of in-home use. Three sizes fit any need such as 7 gallon for apartments and desk side at work, 14 gallon for the average home, and 26 gallon for public facilities, parks, etc. Their identical shape results in instant recognition throughout the community.

All Shamrock curbside containers are manufactured with Recyclene™, a blend of high-density polyethylene, true household post-consumer recycled plastic, and/or used tires. We are the only curbside container manufacturer who actually uses post-consumer material, not just factory generated regrind. Each container style has been thoroughly tested by an independent testing laboratory to insure durability when used in extreme climate conditions. Our containers are guaranteed for five years against defects in materials and workmanship. Each style is available in your choice of color (except the Stackable II, which is available in black only). And the logo of your choice can be hot stamped in white or a contrasting color.

After you have had an opportunity to review the enclosed literature, please call me at 1-800-822-2342 or 612-332-2100 to discuss pricing, availability or any other questions regarding curbside recycling.

Sincerely,

Mark Smiler
Sales Manager
Recycling Containers

Recycling Containers That Keep the Consumer in Mind



RC2000™ ...the cadillac of the industry

*One-Step recyclers are available
in three handy sizes...7-gallon,
14-gallon, and 26-gallon*



*Stackables are made
with up to 100% post-
consumer plastics*

After all, it's the consumers that make or break your curbside recycling program. Shamrock Industries, Inc., a national leader in both the plastics industry and the curbside recycling container market, has a user friendly recycling container to fit every need.

Our innovative product line includes:

- The only containers designed with aesthetics in mind to encourage in-home use.
- A **wide variety** of sizes and types to fit both commingled and source separated programs.
- The only container available with **optional lid and wheels**.
- The use of up to **100% true post-consumer plastics**, making Shamrock the industry leader.

Call today for details on how you can use Shamrock containers to create a successful curbside recycling program.

*Three-Bagger heavy-duty
21-gallon container*

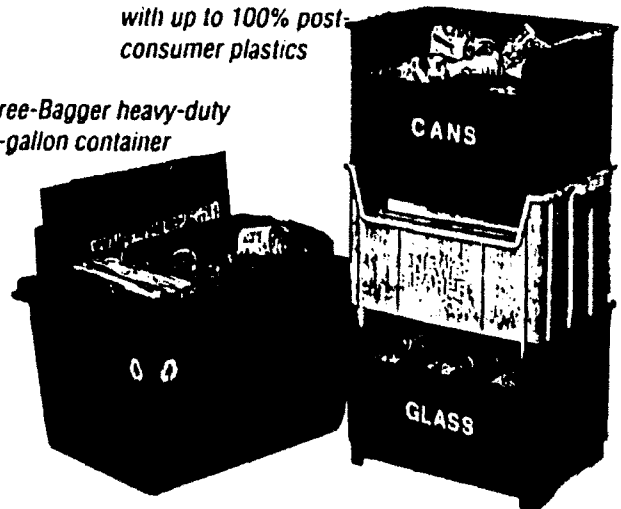

Shamrock®
INDUSTRIES, INC.

Recycling Division
834 North 7th Street
Minneapolis, MN 55411-4394, U.S.A.
(612) 332-2100; 1-800-822-2342 (Toll Free);
1-800-822-2343 (In MN)

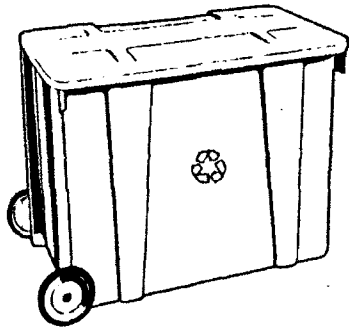

RC2000™ Recycling Container

- Designed to hold three full grocery bags of recyclables.
- 17.75" height fully encloses bags, preventing litter.
- Aesthetically designed for in-home use.
- Optional lid and wheel kits available...industry firsts.
- 23.5 gallon capacity—top I.D. 17.84"H x 23.28"W x 13.66"D.
- Nests or stacks with or without lids.

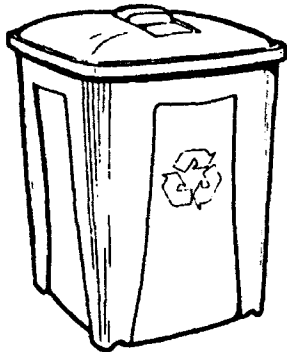

One-Step Recycler

- Aesthetically designed for in-home use.
- Three sizes to fit a wide variety of needs—7, 14, and 26 gallon.
- Optional snug fitting lids and metal carrying/locking handles.
- Identical shape of all three sizes results in instant recognition throughout the community.
- 26.5 gallon capacity—top I.D. 22.50"H x 17.25"W x 17.25"D.
- 14.25 gallon capacity—top I.D. 18"H x 14.50"W x 14.50"D.
- 6.6 gallon capacity—top I.D. 14.25"H x 11.38"W x 11.38"D.

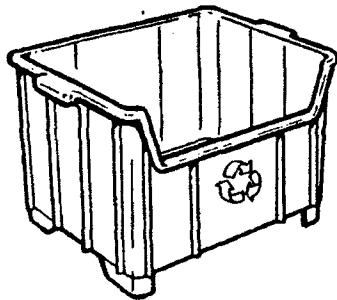

Stackable Recycling Container

- Solid wall construction for safety and to minimize weather and ground problems.
- Double-reinforced handles for easy carrying.
- Units stack securely with interlocking feet.
- Made with up to 100% recycled plastics.
- 11.37 gallon capacity—top I.D. 11.25"H x 17.50"W x 13.50"D.

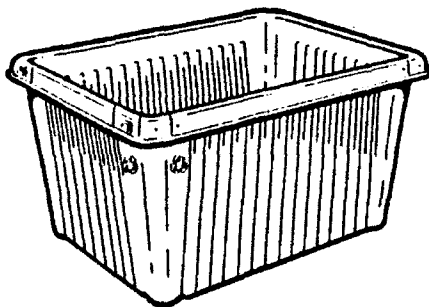

Three-Bagger Recycling Container

- Holds three large grocery bags plus additional room for corrugated or extra paper.
- Rounded top lid makes a comfortable handle.
- Designed with extra height to protect contents and keep them inside bags.
- Optional wheel kit available.
- 20.95 gallon capacity—top I.D. 13.87"H x 24"W x 17.25"D.

Designed with the household and hauler in mind, all Shamrock curbside recycling containers are:

- Available with a blend of "true household post-consumer" resin—up to 100% in some models.
- Guaranteed and fully proven to perform in temperature extremes from -30 degrees to +130 degrees F.
- Made from strong resilient polyethylene.
- Built with solid wall construction for safety and to minimize the consequences of wind, rain, insects, and litter.
- Available in a wide variety of colors and with customized imprints.
- Molded with external handles for comfortable carrying.
- Designed with drain holes but have a reservoir for casual spillage.





WINDSOR
Barrel Works



*bold graphics
and restrictive
openings...*

keys to recycling success.

Canables™ (kan'-a-bl)
cans able to collect recyclables.



 **Canables™**

WINDSOR
Barrel Works

Canables™ are tough steel barrels painted with oven-baked enamel and lids made of ABS plastic. They're great for parks, streets, malls and vending areas.

Reuseable Liner Bag & Ring



Handles



Plain Canables™



Bag and Ring*

Convenient for handling collected recyclables. Bags are made of durable, woven plastic and have a drawstring. Retainer ring holds bag in place and out of sight.

Handles*

For lifting and emptying, especially when a liner is not used.

Plain Canables™

Add your own graphics or use as a companion container for collecting non-recyclables.

Lid for Newspaper*

Enlarged opening with added weather protection.

*additional cost

Ordering Information

Canables™ include the recycling message of your choice. Choose from the messages listed to the right. Be sure to indicate your choice with your order.

Two color choices: blue or green.

Please call for an estimate of shipping costs. We can pre-pay and add them to your invoice.

- CANS
- GLASS
- PLASTIC
- CANS & GLASS
- NEWSPAPER
- TRASH

Custom colors & messages are available in quantity and at an additional cost

For more information, please contact:

WINDSOR BARREL WORKS
P.O. Box 47, Kempton, PA 19529
(800) 527-7848
(215) 756-4344

WB Recyclers™



*a solution for
institutions...*

attractive, all-steel
containers for fire-safe
collection of recyclables.



WB Recyclers™ fit well into an office environment and help create awareness of your recycling program. Some models are UL® listed to conform to strict fire safety codes.

WB Recyclers™ for paper.



Slot: 1 1/2" x 14"

Model for cans & bottles with optional liner.



Hole: 2 1/2" diameter

Rectangular "WB" makes efficient use of space.

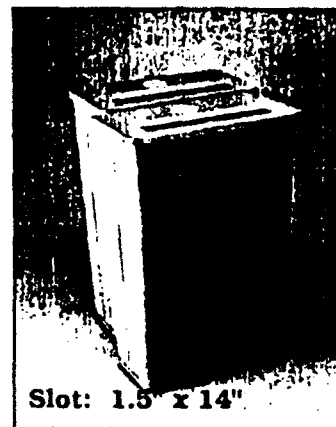

Slot: 1.5" x 14"

Security Recyclers™

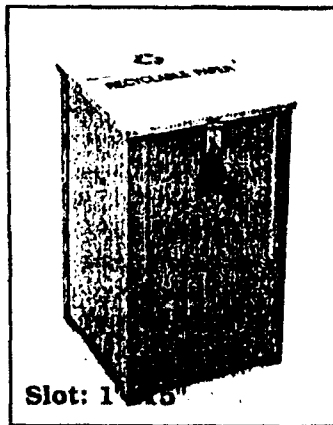

Slot: 1 1/2" x 14"

WB Recyclers™ with plastic base.



WB Recyclers™ and matching waste basket.



Ordering Information

WB Recyclers™ include the message of your choice and the universal recycling symbol. Choose from the recycling messages listed to the right. Be sure to indicate choice with your order.

WB Recyclers™ are packaged 3 per carton; order in multiples of three.

Please call for an estimate of shipping costs. We can pre-pay and add them to your invoice.

- RECYCLABLE PAPER
- OFFICE PAPER
- WHITE PAPER
- COLORED PAPER
- COMPUTER PAPER
- NEWSPAPER
- CANS & BOTTLES
- ALUMINUM CANS
- GLASS BOTTLES

Custom colors, messages & graphics are available at an additional cost

For more information, please contact:

WINDSOR BARREL WORKS
P.O. Box 47, Kempton, PA 19529
(800) 527-7848
(215) 756-4344

clusters



*innovative
containers
for collecting
recyclables in
public places.*

*durable, distinctive, and
recycled too!*





Barrels

Each barrel (designated CL) consists of a steel drum with Durawood™ slats (a recycled plastic product) bolted fast to create an attractive & rugged container for outdoor environments. Combine barrels into Clusters™ of 2, 3, or 4, to suit your recycling program's needs.

Colors: Brown, Redwood, Weathered Gray

Center Post

The center post and recycling symbol alert people to the special function of Clusters™. The Center Post is a recycled material, made of mixed waste plastics and sawdust. Assembly Brackets connect barrels and post together (1 bracket set per Cluster™).

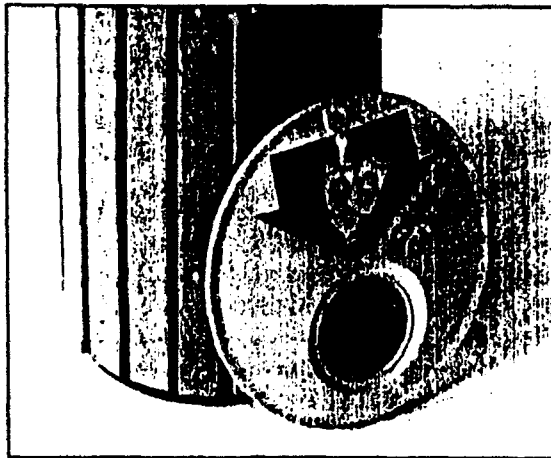

Locking Lid

Our best selling barrel, the CL 30, includes this lid with a built-in lock. The lock helps keep the lid in place and recyclables inside. Made of recycled aluminum, it contributes to Clusters™ durability and recycled content too!

Lids

CL 20- made of plastic, with optional locking bar.

CL 30- made of cast-aluminum, with a built-in lock.

Lid hole sizes:

- 4.5" - CANS, GLASS, CANS & GLASS
- 6" - TRASH, PLASTIC

A special lid for NEWSPAPER is available.

Liners

A reusable liner bag is included with each barrel. It is made of woven polypropylene and has a drawstring closure. Rigid plastic liners are also available.

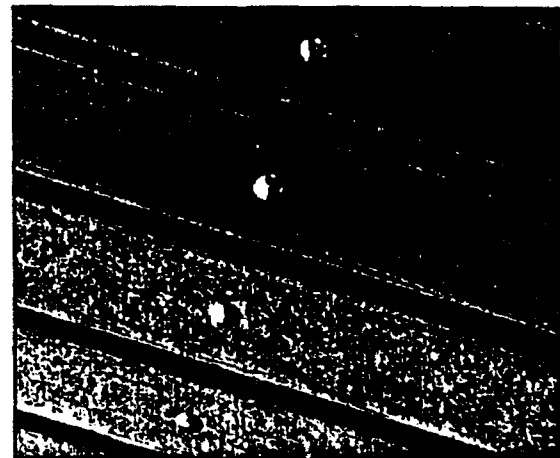

Durawood™

100% post-consumer, recycled plastic; resists cracking, fading, water & stains.

Clusters™ made of Durawood™

- provide excellent visibility for recycling
- highlight potential uses of recycled products
- help meet purchasing guidelines requiring recycled content.

Ordering Information

Multiply CL prices by the number of barrels you want per Cluster™, plus post, brackets, and any accessories to arrive at a total Clusters™ price.

Specify the message you want on each lid. We recommend brief messages such as:

- CANS
- GLASS
- CANS & GLASS
- PLASTIC
- NEWSPAPER
- TRASH

Prices do not include shipping. We can pre-pay shipping costs and add them to your invoice.

For more information, please contact:

WINDSOR BARREL WORKS
P.O. Box 47, Kempton, PA 19529
(800) 527-7848
(215) 756-4344

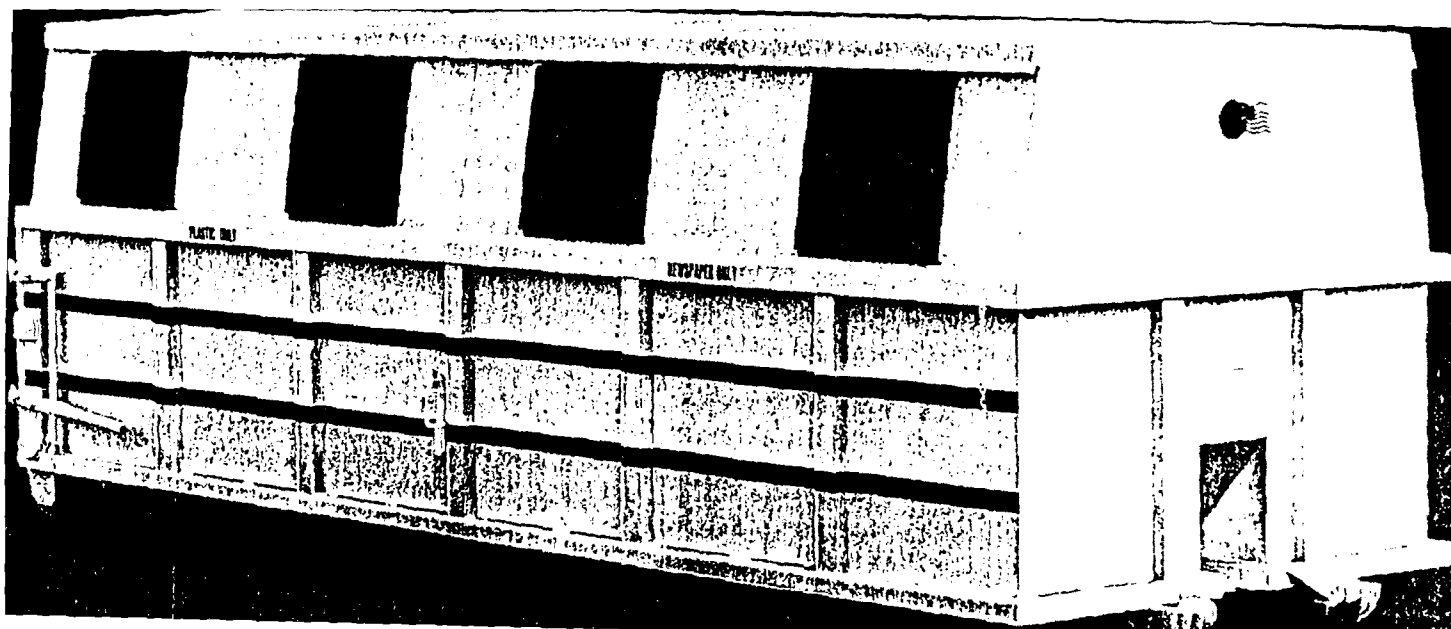

VALUE, DESIGN, DEPENDABILITY. THAT'S WHAT YOU GET FROM THE HESCO RECYCLING ROLL-OFFS.

Hesco Recycling Roll Off Containers are designed and engineered to fit your specific requirements. Hesco incorporates the same high quality techniques and workmanship standards in our recycling containers as you've come to expect from our durable field tested open tops. Whether your needs are for rural collection of recyclables or urban drop off sites, let Hesco custom design a recycling container to fit your individual needs.

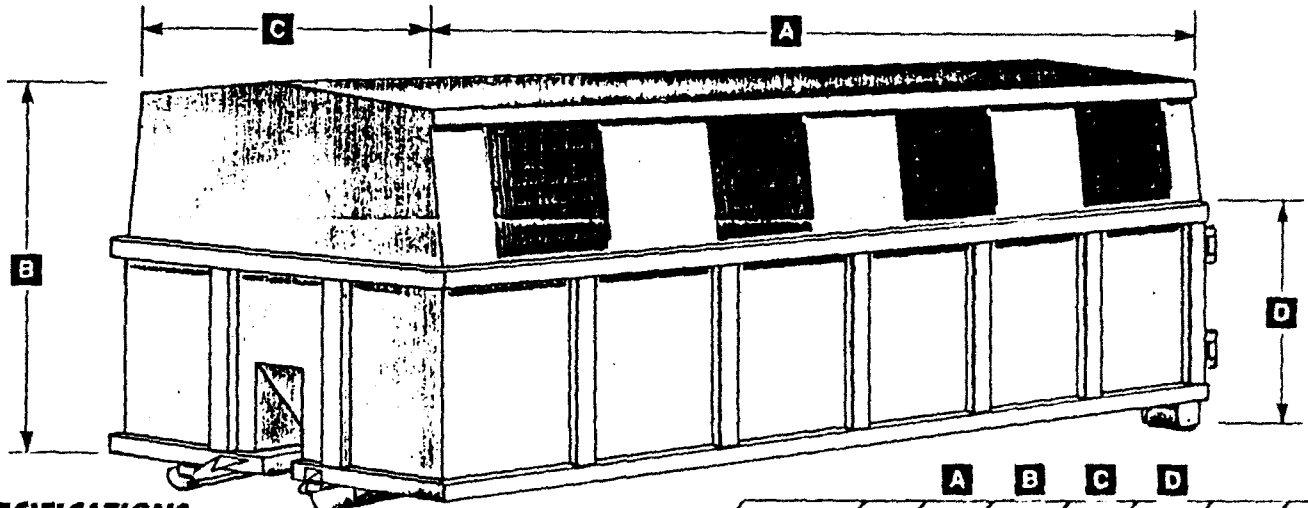

SPECIFICATIONS

Container:

- Floor— 10 Gauge H.R.S.
- Single Rear Door.
- Sides, Top, Door— 12 Gauge H.R.S.
- Multiple Access 30" x 30" Plastic Sliding Doors.

Understructure:

- 6" x 2" x 3/16" Bottom Rails.
- 3" x 4.1# Channel on 20" Centers.
- Rear Rollers—6" Heavy Wall Black Pipe.
- 1 1/4" Solid Pull Hook.
- Partitions/Dividers— 12 Gauge H.R.S. construction with 3" structural channel around edge of dividers.
- Hesco Exclusive Quick-Loc Dividers Lock Mechanism is made of heavy duty 3/8" Plate which conveniently lifts up to lock dividers or quickly release and lowers to unlock.
- Driver/Operator can instantly determine whether divider is locked or unlocked.
- Up to 6 Compartments on selected models.

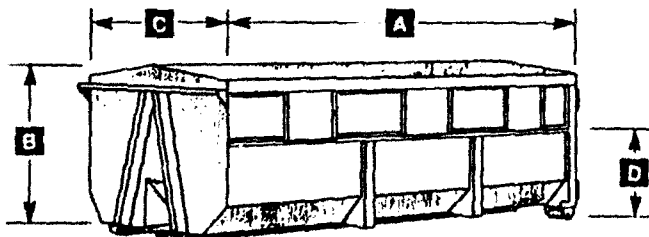

MODEL	CAP. CY	OVERALL LENGTH	OVERALL HEIGHT	OVERALL WIDTH	LOADING HEIGHT	INSIDE HEIGHT	APPROX. WEIGHT
ROR 4024	40	25'	86"	96"	50"	74"	5507 lbs.
ROR 4022	40	23'	93"	96"	57"	81"	5407 lbs.
ROR 3522	35	23'	82 1/2"	96"	46 1/2"	70 1/2"	5089 lbs.
ROR 3120	31	21'	82"	96"	46"	70"	4627 lbs.
ROR 2818	28	19'	82"	96"	46"	70"	4162 lbs.
ROR 2012	20	13'	86"	96"	50"	74"	2703 lbs.
ROR 2715	27	16'	93"	96"	57"	81"	3683 lbs.
ROR 2916	29	17'	93"	96"	57"	81"	3968 lbs.
*RORS 2916	29	17'	92"	94"	52"	80"	3581 lbs.

*Newspaper

Add approx 250 lbs. of additional weight for each divider

- Each Recycling Container is Reinforced with 4" x 3" x 11 Gauge Structural Tubing around mid section of container which serves as main support section of top and bottom. Side Walls are additionally reinforced with 5" Formed Channel. Five supports each side running vertically on side of container.
- Containers are available with Optional Deadlift, Dino, or Amprill Understructures.

Newspaper Container

Hesco Newspaper Collection Containers can be custom designed to your individual requirements. Available from 10' to 25' long with or without dividers. Your choice of plastic or steel sliding doors. Tapered side walls allow for more complete loading of center section. Please call us for details and let us show you why "NOBODY BUILDS 'EM BETTER."

U.S. Container Corp.
27137 South Highway 33
Okahumpka, Florida 34762
TEL: (904) 728-1089
FAX: (904) 326-5796

HESCO
Nobody builds 'em better.

Hesco Sales, Inc
8505 N.W. 74th Street
Miami, Florida 3316
TEL: (305) 597-024
FAX: (305) 594-422



UNITED TRUCK & BODY CORP
U.S. CONTAINER CORP.
U.S. CYLINDER CORP.

Manufacturers of a complete line of solid waste and Recycling Equipment

Dear Sir,

Hesco is a major manufacturer of waste handling recycling, and speciality application products to include cylinders. We have been manufacturing products since 1962

Our new 100,000+ sq. ft manufacturing facility and corporate offices are located on 30 acres of land in Miami, Florida. It is "state of the art".

Our product line includes most every item required in the solid waste and recycling industries. Specialty products include: Fuel blenders, oil filter and can crushers, tarp covers, plastic bottle crushers, and a list of other items.

The latest addition to our product line are the Recycling Roll-Off Containers. A copy of the specification sheet is enclosed. Attractive pricing and delivery is available.

We would appreciate the opportunity to do business with you. Please Call:

1-800-934-3726
FAX-305-594-4228

We look forward to talking with you in the near future.

P.S. Please visit us at the World Recycling Conference & Exposition Show at Booth 711 - Chicago, Illinois June 2-4, 1992 at the Rosemont Exposition Center.

APPENDIX J

SPI Bottle Code

**EXHIBIT III-6
SPI BOTTLE CODE**

PBI, in cooperation with its member companies, established a nationally recognized voluntary material identification system to assist separators of plastic bottles and create a higher value for recycled material.







The Plastic Container Code System is beneficial largely because of the uniformity it offers to bottle manufacturers and recyclers alike. Several states, as well as many bottle and product manufacturers, have recently adopted the code system. Full use will be gradually phased in over three years, with most bottles coded by mid-1991.

Bottles are coded by the six most widely used resins. Here is what to look for:

PLASTIC BOTTLES 16 OZ. CAPACITY AND LARGER
(Other rigid plastic containers, such as tubs and trays, 8 oz. and up)

LOCATE CODE ON BOTTOM OF BOTTLE OR CONTAINER
(Or as near as possible with special shapes)

SIZE OF SYMBOL: MINIMUM 1/2 IN. - MAXIMUM 1 IN

CODE	MATERIAL	% OF TOTAL BOTTLES
 PETE	----- Poly-Ethylene Terephthalate (PET)*	20-30%
 HDPE	----- High Density Polyethylene	50-60%
 V	----- Vinyl / Polyvinyl Chloride (PVC)*	5-10%
 LDPE	----- Low Density Polyethylene	5-10%
 PP	----- Polypropylene	5-10%
 PS	----- Polystyrene	5-10%
 OTHER	----- All Other Resins and Layered Multi-Material	5-10%

*Stand alone bottle code is different from standard industry identification to avoid confusion with registered trademarks.

APPENDIX K

A Homeowner's Guide to Recycling Yard Wastes

THE BENEFITS OF REUSING YARD WASTES

Mulching:

Mulch reduces evaporation from the soil surface, keeps down weeds, and keeps soil temperatures from becoming too hot or too cold. Mulch also protects sloping ground from soil erosion and it stops soil compaction caused by driving rain on any soil surface.

In addition, mulch provides ideal conditions for earthworms and other soil organisms that are necessary for a healthy soil. When mulches break down, they become a compost that feeds the soil.

Composting:

Composting is the controlled decomposition of organic materials using aerobic bacteria. The composting process reduces material volume by 70-80 percent. By using compost you return organic matter to the soil in a usable form. Organic material in the soil improves plant growth by loosening heavy clay soils, which allows better root penetration; by improving the capacity to hold water and nutrients in sandy soils; and by adding essential nutrients to any soil. Improving your soil is the first step toward improving the health of your plants. Healthy plants help clean our air, conserve our soil, and beautify our landscapes.

Other Savings:

Fewer plastic trash bags to buy
Reduces water usage
Eliminates the need to purchase peat moss and other soil conditioners



Illinois Department of
Energy and Natural Resources



Office of Solid Waste
and Renewable Resources

If you have additional questions,
contact:

Illinois Department of
Energy and Natural Resources
Office of Solid Waste
and Renewable Resources
325 West Adams Street
Springfield, IL 62704-1892

(217) 524-5454
(312) 917-3896
1-800-252-8955

This brochure is based in part on
material published by
the State of Wisconsin,
City of Seattle, and
Ramsey County, Minnesota

Printed by the Authority of the State of Illinois
(STA 9-50M-8.00)

ILENR/RR-89/03

A Homeowner's Guide to Recycling

YARD WASTES

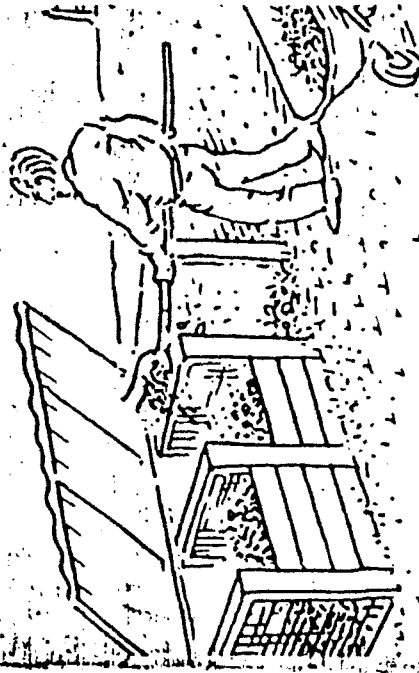

How to improve the health
and quality of your yard
and garden by using

- ✓ Grass Clippings
- ✓ Leaves
- ✓ Wood Chips



Illinois Department of
Energy and Natural Resources

On average, yard waste, accounts for 18 percent of all the material buried in Illinois landfills each year. During the summer and fall months, yard waste can amount to 50 percent or more of residential trash (with collection and disposal costs at about \$90 per ton!).

Illinois is fast running out of landfill space. Yard waste not only uses up this valuable space, but contributes to methane gas and leachate problems, as well. Yard waste also makes incinerators less efficient because of its high moisture content. So, keeping your yard waste out of the garbage truck saves money and protects the environment.

HOW TO USE:

Grass Clippings

- Leave them on the lawn
- Mulch
- Compost

Leaves

- Mulch
- Compost

Wood Chips

- Mulch
- Pathways

WHY BAG YOUR GRASS CLIPPINGS?

After all, lawn care is hard work. And bagging your lawn clippings is one of the most time-consuming parts of the job. Sure, your lawn looks great afterwards. But, the bigger your lawn, the more clippings, the more trash bags — the more exhausting the process.

Now, consider for a moment not bagging your grass. Gone are the hassles of stopping every few minutes to empty the mower bag, raking, wrestling with expensive trash bags. Instead, your clippings are working their way back into the soil.

You may say, not bagging your grass is unhealthy for your lawn ... will cause excessive thatch buildup and kill your lawn.

The fact is, thatch is not made up of grass, but of roots, dead leaf sheaths, and rhizomes, which decompose slowly. Grass clippings decompose rapidly and can help make your lawn more vigorous and durable.

Clippings contain the nutrients your lawn needs to grow. Every garbage bag of grass clippings contains up to 1/4 pound of usable organic nitrogen. You can reduce your fertilization costs by recycling lawn clippings back into the lawn.

GRASS CLIPPINGS HELP:

- Reduce water evaporation from the lawn.
- Reduce lawn wear by creating a cushioning layer, and
- Facilitate better growth by providing nutrients and keeping the soil temperature cooler.

Successfully recycling grass clippings back to your lawn requires only the kind of attention all lawns should have on a regular basis.

- Mow when your grass is dry and 3" to 4" tall. Never cut it shorter than 2" to 2 1/2" in height. This height will allow your lawn to have a larger and deeper root system — making a stronger defense against weeds and droughts.

Use a sharp mower blade (a mulching mower if you have one). A sharp blade and frequent mowing will mean finer clippings that will decompose quickly.

• Avoid over-fertilizing your lawn. If it becomes too dense with growth, your clippings won't reach the soil to decompose.

• Remove excessive thatch before leaving your clippings on the lawn. Although a half inch of thatch is no problem, a thick layer will keep clippings from reaching the soil.

• Limit the use of lawn chemicals. Save money and allow soil organisms to return nutrients to the soil by first correctly diagnosing lawn problems and then applying corrective measures only when needed.

MULCHING TIPS

Grass Clippings can be spread in thin layers over vegetable and flower beds, or mixed with leaves and spread in a thicker layer.

Leaves of deciduous trees can be spread around shrubbery in the fall.

Wood Chips can be used around trees and shrubs or to make a good-looking, long-lasting path.

HOW TO MAKE COMPOST

HOW TO MAKE COMPOST

Here are the basics:

Remove grass and sod cover from the area where you will construct your compost pile to allow materials direct contact with soil microorganisms. The following "recipe" for constructing your compost heap is recommended for best results:

1st layer: 3"-4" of chopped brush or other coarse material on top of the soil surface allows air circulation around the base of the heap.

2nd layer: 6"-8" of mixed kitchen scraps, leaves, grass clippings, sawdust, etc. Materials should be "sponge damp".

3rd layer: 1" of soil serves as an inoculant by adding microorganisms to the heap.

4th layer: 2"-3" of manure or commercial fertilizer to provide the nitrogen needed by microorganisms. Sprinkle lime, wood ash, and/or rock phosphate over the layer of manure to reduce the heap's acidity. Add water if the manure is dry.

5th layer: Repeat steps 1-4 until the bin is almost full. Top off the heap with a 4"-6" layer of straw, and scoop out a "basin" at the top to catch rain water.

A properly made heap will reach temperatures of 140°-160° in four to five days. At this time, you'll notice the pile "settling," a good sign that your heap is working properly.

After five to six weeks, fork the materials into a new pile, turning the outside of the old heap into the center of the new pile. Add water if necessary. You shouldn't need to turn your heap a second time. The compost should be ready to use within three to four months. A heap

Wooden Bin

Covered wooden bins allow convenient protection from pests and heavy rains. Construct bins with removable fronts or sides so that materials can be easily turned. Old wooden pallets can be used for construction. Wire mesh can be substituted for wooden sides to increase air flow.

Prefabricated compost bins can also be purchased through most gardening catalogues.

Turning Bins

This is a series of three or more bins that allows you to make compost in a short time by turning the materials on a regular schedule. Turning bins are most appropriate for gardeners with a large volume of yard waste and the desire to make a high-quality compost. You can also turn your compost with only one bin. Simply remove the bin from around the heap when it's time to turn it, set up the empty bin nearby, and fork the material back into it.

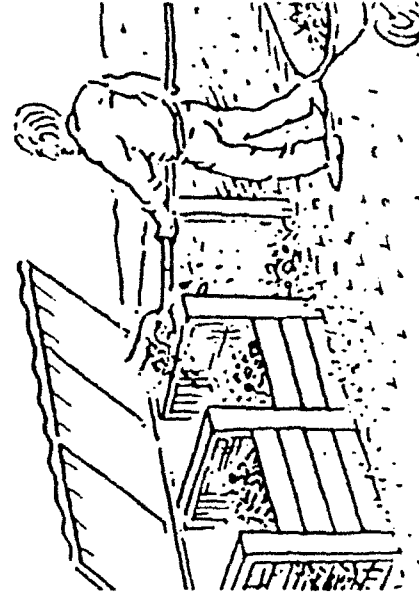

in the autumn. Start another heap in autumn for use in the spring.

You can make compost even faster by turning the pile more often. Check the internal temperature regularly; when it decreases substantially (usually after about a week), turn the pile.

Compost is ready to use when it is dark brown, crumbly, and earthy-smelling. Let it stabilize for a few extra days and screen it through a 1/2" screen if you want the finest product. Turn your soil, apply 1"-3" layers of compost, and work it in well, up to one pound (a heaping, double handful) per square foot.

The following troubleshooting chart is a guide to more efficient composting.

Symptoms	Problem	Solutions
The compost has a bad odor.	Not enough air.	Turn it. Add dry material if the pile is too wet.
The center of the pile is dry.	Not enough water.	Moisten and turn the pile.
The compost is damp and warm only in the middle.	Too small.	Collect more material and mix the old ingredients into a new pile.
The heap is damp and sweet-smelling but still will not heat up.	Lack of nitrogen.	Mix in a nitrogen source like fress grass clippings, fresh manure, or bloodmeal

...the reproduction

THE ESSENTIALS

OF COMPOSTING

Biological Process

The compost pile is really a teeming microbial farm. Bacteria, the most numerous and effective composters, are the first to break down plant tissue. Fungi and protozoans soon join the bacteria and, somewhat later in the cycle, centipedes, millipedes, beetles and earthworms do their parts.



Materials

Anything growing in your yard is potential food for these tiny decomposers. Microorganisms use the carbon in leaves or woodier wastes as an energy source. Nitrogen provides the microbes with the raw element of proteins to build their bodies.



Everything organic has a ratio of carbon to nitrogen (C:N) in its tissues. The following table can help you judge the ratio of your compost ingredients.

Carbon : Nitrogen Ratio

Food Wastes	15:1
Leaves	60:1
Wood	700:1
Fruit Wastes	35:1
Sawdust	500:1
Rotted Manures	20:1
Straw	80:1
Cornstalks	60:1
Grass Clippings	19:1
Alfalfa Hay	12:1

A C:N ratio of 30:1 is ideal for the activity of compost microbes. This balance can be achieved by mixing two parts grass clip-

plings with one part fallen leaves. This combination is the "backbone" of most compost systems.



Surface Area

The more surface area the microorganisms have to work on, the faster the materials decompose. Chopping your garden wastes with a garden tool, or running them through a shredding machine or lawnmower, will speed their composting.



Volume

A large compost pile will insulate itself and hold the heat of microbial activity. Its center will be warmer than its edges. Piles smaller than 3 feet cubed (27 cu.ft.) will have trouble holding this heat, while piles larger than 5 feet cubed (125 cu.ft.) don't allow enough air to reach the microbes at the center. These proportions are of importance only if your goal is a fast, hot compost. Slower composting requires no exact proportions.

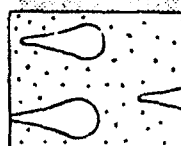

Moisture and Aeration

All life on Earth, including compost microbes, needs a certain amount of water and air to sustain itself. Microbes function best when the compost heap has many air passages and is about as moist as a wrung-out sponge. Extremes of sun or rain can adversely affect this moisture balance.

FOUR BINS TO BUILD

Snow Fence Bin

Bins made with prefabricated snow fencing are popular because they are simple to make and easy to move and store. To build this bin, buy the appropriate length of prefabricated fencing and fasten two-by-fours (2X4s) to the bottom to form a square.

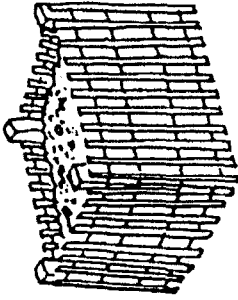

Woven Wire Bin

One easy-to-make, economical container requires only a length of woven wire fencing. Multiply the diameter you want for the compost heap by 3.2. That's the length of fencing you should buy. Fasten the ends with wire or with three or four small chain snaps (available at any hardware store) to make a circle.

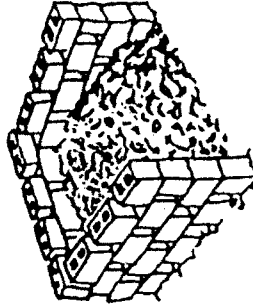
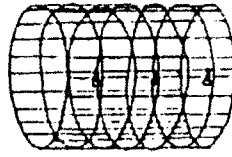

Block or Brick Bin

Compost bins can be made with bricks, cement blocks or rocks. Just lay the blocks without mortar. Leave spaces between each block to permit aeration. Pile them up to form three sides of a square container or a three-bin unit. This bin is sturdy, durable and easily accessible.