

TNO Defence Research

TNO Prins Maurits Laboratory
TD 922743

Lange Kleiweg 137
P.O. Box 45
2280 AA Rijswijk
The Netherlands

Fax +31 15 84 39 91
Telephone +31 15 84 28 42

Handwritten initials and 'TD' stamp

TNO-report
PML 1992-77

January 1993
Copy no.: /

Experimental Investigations into the
Deflagration to Detonation Transition at
TNO-PML

AD-A266 753



Author(s):

H.J. Verbeek
R. Oostdam
E.G. de Jong
DO-assignment no.
A80/KL/137

Classification

Report:

ONGERUBRICEERD

Title:

ONGERUBRICEERD

Summary:

ONGERUBRICEERD

DTIC
S ELECTED
JUL 14 1993
E D

TDCK RAPPORTENCENTRALE

Frederikkazerne, gebouw 140
v/d Burchlaan 31 MPC 16A
TEL. : 070-3166394/6395
FAX. : (31) 070-3166202
Postbus 90701
2509 LS Den Haag

Number of copies:

38

Number of pages:

(incl. annex(es), excl. distr. list and RDP)

31

Number of Annexes:

The classification designation:

ONGERUBRICEERD

is equivalent to:

UNCLASSIFIED

All rights reserved.

No part of this publication may be reproduced and/or published by print, photoprint, microfilm or any other means without the previous written consent of TNO

In case this report was drafted on instructions, the rights and obligations of contracting parties are subject to either the 'Standard Conditions for Research Instructions given to TNO', or the relevant agreement concluded between the contracting parties.

Submitting the report for inspection to parties who have a direct interest is permitted

© TNO

~~RESTRICTED STATEMENT~~
Approved for public release
Distribution Unlimited

All information which is classified according to Dutch regulations shall be treated by the recipient in the same way as classified information of corresponding value in his own country.

No part of this information may be disclosed to any party.

93

028

93-15904



DISCLAIMER NOTICE

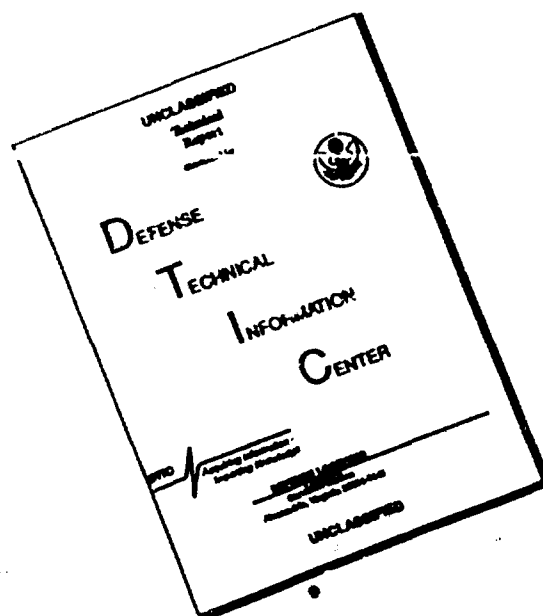

THIS DOCUMENT IS BEST QUALITY AVAILABLE. THE COPY FURNISHED TO DTIC CONTAINED A SIGNIFICANT NUMBER OF PAGES WHICH DO NOT REPRODUCE LEGIBLY.

Summary

This report presents an overview of the experimental research that has been performed at TNO-PML from 1988 to 1991 on the subject of the transition from a deflagration to a detonation (DDT) in solid explosives. A full description is given of the set-up used for the experiments, of the development in time of the set-up and of the rationale for the applied changes. Among the experimental results that are presented, the influence on the DDT process is shown of variations in parameters such as the tube geometry, the explosive density, the particle size and the igniter strength. The results obtained at a relatively low wall thickness of the test-tube are particularly notable.

Samenvatting

In dit rapport wordt een overzicht gegeven van het experimentele onderzoek dat is uitgevoerd op PML-TNO gedurende de periode 1988 t/m 1991 op het gebied van de overgang van een deflagratie naar een detonatie (DDT) in explosieve stoffen. Er wordt een uitgebreide beschrijving gegeven van de wijze waarop de experimenten zijn opgezet, van de wijzigingen die daarbij in de loop van de tijd zijn doorgevoerd en van de redenen voor die wijzigingen. Bij de presentatie van de experimentele resultaten wordt de invloed op het DDT proces gedemonstreerd van variaties in experimentele parameters zoals de afmetingen van de gebruikte buis, de dichtheid en de deeltjesgrootte van de explosieve stof en de kracht van de ontsteker. Met name de experimenten verricht in relatief dunwandige buizen leveren opmerkelijke resultaten op.

Accession For	
NTIS CRA&I	<input checked="" type="checkbox"/>
DTIC TAB	<input checked="" type="checkbox"/>
Unannounced	<input type="checkbox"/>
Justification	
By _____	
Distribution/	
Availability Codes	
Dist	Avail and/or Special
A-1	

CONTENTS

	SUMMARY/SAMENVATTING	2
	CONTENTS	3
1	INTRODUCTION	4
2	DEVELOPMENT OF THE TUBE TEST	5
2.1	Tube geometry	5
2.2	Tube loading	6
2.3	The igniter system	8
2.4	Properties of the tested explosives	9
2.5	Description of the measuring method	10
3	EXPERIMENTAL RESULTS	11
3.1	Chronological overview	11
3.2	Description of the results	12
4	DISCUSSION	24
4.1	General	24
4.2	The interpretation of the signals obtained from the measuring probes	24
4.3	The influence of the igniter system and of density fluctuations in the explosive material	25
4.4	The influence of particle size and density	25
4.5	The influence of the confinement	27
5	FURTHER DEVELOPMENTS	28
6	CONCLUSION	28
7	AUTHENTICATION	29
8	REFERENCES	30

1 INTRODUCTION

Over the last decades, considerable effort has been put into the study of the transition from a deflagration into a detonation (DDT) in explosive materials in many laboratories. Among this research, the work at the Naval Surface Warfare Centre (formerly Naval Ordnance Laboratory) at White Oak, Maryland, USA, stands out both because of the extent and systematics of the research, and because of the broad application area implying research on both cast and pressed high explosives and on propellants (see reference 1). From this and other research, a good understanding has been acquired of the phenomena that occur during a DDT and of the factors that can influence the DDT process. It appears that the DDT behaviour is in fact a property of the total explosive system. It depends on both the chemical properties of the explosive (burn-rate, composition, ignitability, heat conductivity, heat capacity, stability, etc.), its mechanical properties (density, homogeneity, grain size, grain shape, friability, etc.) and on its sensitivity to shock initiation of detonation. Moreover, the geometrical properties of the explosive system such as the thickness and strength of the container wall, and the type and strength of the igniter system used to initiate the combustion process are also of crucial importance for the development of the DDT process. The consequence is that to determine the DDT sensitivity of an explosive system, all these aspects have to be taken into account.

At the TNO Prins Maurits Laboratory, the DDT effort is aimed at reaching a better understanding of the influence of the various parameters on the phenomenon. The acquired knowledge will also be used to develop a standard DDT test to test explosive materials on their tendency to undergo a DDT under certain circumstances. The DDT programme consists of two parts. One part comprises the simulation of the DDT process using a computer program (see references 2, 3 and 4). In this report the outcome of the simulations will only be mentioned indirectly. Instead, this report concentrates on the other part of the DDT programme, the experimental part, in which a tube test is used to study the DDT phenomenon.

The tube test, used at PML, was at first analogous to the experimental work at NSWC, although the tube dimensions used were different. Later on, however, the test was further refined by an increasingly precise definition of the various parts of the tube test, partly influenced by similar work at ISL in France (see references 5, 6 and 7). Great pains were taken to make the ignition of the explosive as well-defined and reproducible as possible, while also the geometry of the tube and the particle size distribution of the explosive grains were controlled within narrow limits. In the experiments, various parameters such as the tube geometry, the density, the particle size and the strength of the igniter were varied to examine their influence on the DDT process.

In this report, a description is given of the set-up of the tube test. A full account is given of the development in time of this set-up and of the reasons for change in the set-up. Next the results are presented of the experiments performed up to now, followed by a discussion of these results. Finally it is indicated which experiments are likely to be carried out in the near future.

This report gives a full account of the experimental work performed between January 1988 and June 1991. Some of the results have been published before (see references 8, 9, 4 and 10). The research project is being carried out as part of the assignment A80/KL/137: Safe production and storage of propellants.

2 DEVELOPMENT OF THE TUBE TEST

2.1 Tube geometry

The experiments are performed in thick-walled stainless steel tubes that have been honed to obtain a constant inner diameter and a smooth inner surface. The tubes are closed at both ends with steel screw caps (see Figure 1). The tubes are almost completely filled with the explosive material to be investigated apart from a part with a length of 10 to 25 mm at one end of the tube that is used for the igniter system. From measurement number 36 onward, at the opposite end of the tube, the part of the tube that is covered on its outside by the screw cap has been filled with a stainless-steel cylindrical piece, since it is not possible to carry out measurements in this part of the tube. In one experiment, instead of a stainless-steel filling piece, a PVC one has been used.

Several holes are drilled in the tube to provide access to the interior for the igniter leads and the measuring probes. At the igniter end, a hole with a diameter of 3.8 mm is bored to provide a feedthrough for the igniter leads, where the remaining space is filled up afterwards with glue. Along the length of the tube, several holes of 1 mm diameter are drilled to provide feedthroughs for the measuring probes. Also in this case, the holes are filled up as much as possible by using Teflon tubes around the probes and glue, in order to preserve the confinement as much as possible. The probes are located at constant intervals in the order of 30 mm from each other and are placed spirally along the tube with a difference in angle of 120° with respect to each other so as not to impair the strength of the tube.

Table I Overview of used tube geometries

Test series	experiment no.	tube geometry			probe location	
		inner diameter (mm)	outer diameter (mm)	length (mm)	1 st probe* (mm)	distance (mm)
I	1 - 17	15.9	33.4	200	35	20
II	18 - 23	36.2	64	327	50	35
III	24 - 29	15.9	33.4	200	35	20
IV	32 - 35	36.2	64	327	35	30
V	36 - 47	28.2	54	358	35	30
VI	48 - 66	16.2	34	334	35	30

* the location of the first probe is given relative to the igniter/explosive interface

Several tube geometries have been used (see Table I). Originally two types were used, one large one with dimensions of 36.2 mm inner diameter and 64 mm outer diameter and a smaller one with dimensions of 15.9 mm inner diameter and 33.4 mm outer diameter. Later also tubes with dimensions of 28.2 mm inner diameter and 54 mm outer diameter were used. Experiments with dimensions of 16.2 mm inner diameter and 44 mm outer diameter will be carried out in the near future. The overall lengths of the tubes are in the order of 300 mm, although in the first stages of the experimental programme many experiments with the small tube have also been carried out with lengths in the order of 200 mm.

2.2 Tube loading

In order to produce reproducible measurements it is very important in a DDT experiment that the density distribution of the explosive material is as homogeneous as possible. Another important factor is that there should not be a gap between the explosive material and the tube wall, to avoid flamespreading through this void. To attain these goals, when filling a tube with granular explosive material, it is necessary to hone the tube and to press the grains directly in the tube. The procedure with which this is done is as follows. A previously determined amount of explosive material is inserted into the tube and then pressed with a previously determined pressure corresponding to the desired density. The amount of explosive material has been determined in such a way that as a result the pressed column of grains has a height that is equal to the diameter of the tube. This procedure is repeated until the tube has almost been filled to the desired height. The remaining part of the tube, which in general will be smaller than the tube diameter, is filled by inserting a proportionally smaller amount of explosive material into the tube and pressing it with the same predetermined pressure. After each filling/pressing operation the height of the explosive material in

material in the tube is measured to watch the homogeneity. With this procedure it appeared possible to reach a reasonably homogeneous density in the tube, where the density is constant within 0.5 %, except for the last pressing operation where often fluctuations in the order of a few % occurred with a few large deviations. Since this is the region that is adjacent to the igniter system and is therefore crucial to the early stages of the DDT process, the loading procedure will be adjusted in future experiments to try to reach a homogeneous density distribution in this region also.

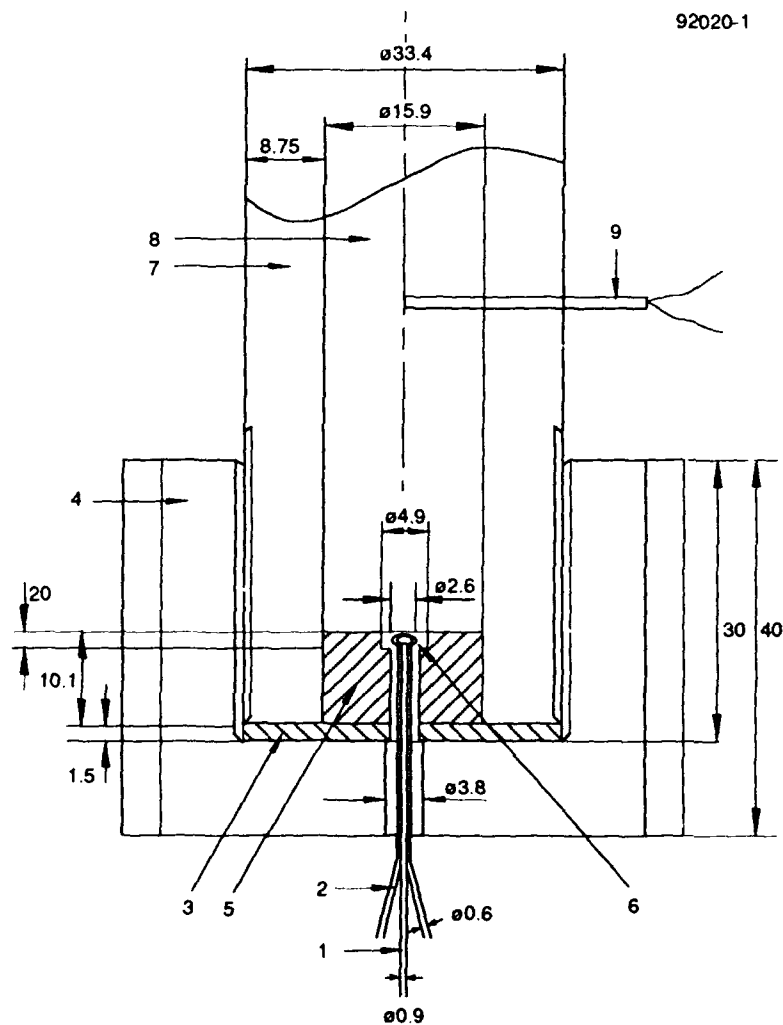

Figure 1 Schematic representation of one end of the DDT tube used in test series I. The dimensions are in millimetres.

- | | |
|--------------------|------------------------------------|
| 1: optical fibre | 6: cavity with pyrotechnic mixture |
| 2: resistance wire | 7: stainless steel tube |
| 3: copper plate | 8: explosive material |
| 4: screw cap | 9: ionization probe |
| 5: PVC cylinder | |

2.3 The igniter system

Since a well-defined and well-controlled ignition is very important to obtain a reproducible development of the DDT process, much care was taken to develop an ignition system that is as well defined as possible. To this end, an ignition system was used that consists of a PVC cylinder with a diameter equal to the inside diameter of the tube and a height of 10 to 25 mm. At one end of this cylinder a cylindrical cavity with a diameter of 5 mm and a depth of 2 mm is made in the centre. In the earlier experiments (see Figure 1), the cavity was connected to the other end of the cylinder by one central hole (diameter 2.6 mm) to provide access to the cavity for two leads of a resistance wire and for an optical fibre. In later experiments (starting with experiment no. 36), instead of one central hole, two small holes (diameter 0.8 mm) located slightly off centre were used, each containing one end of the resistance wire (see Figure 2). A third small hole was provided to contain the optical fibre. The optical fibre was not connected to the cavity but was located a short distance to the side. The resistance wire used was a NiCr wire with a diameter of 0.6 mm and a length of 100 mm. On ignition, a current of 12 A was applied to the resistance wire which had a total resistance of 1 Ohm. The cavity was filled with a fixed quantity of a pyrotechnic mixture. Apart from a number of try-out experiments and the first three experiments of test series I, in which various amounts of the pyrotechnic mixture were used, in our experiments 90 mg was pressed into the cavity. Two different compositions were used in the experiments. One consisted of KNO_3 and Zr (47/53 wt%), and the other of a mixture of lead oxide (Pb_3O_4), tetrazene and boron (85.5/5.0/9.5 wt%). The former mixture produces a considerable amount of gaseous reaction products, while the latter produces mainly hot particles. In the remainder of this report, the ignition system filled with KNO_3/Zr will be referred to as igniter I; when filled with the other mixture it will be called igniter II.

The optical fibre was used to register the time of onset of the chemical reaction. In the earlier experiments, where the fibre was contained in the central hole through the PVC cylinder, it registered the onset of reaction of the pyrotechnic mixture. In the later experiments it registered the onset of reaction in the explosive material itself.

The result of using such an igniter system is that the explosive is ignited very gently at a small central part of the total cross-section of the tube. Although the convective combustion process, generated in the explosive material, is not well defined and reproducible by its very nature, at least by this ignition method the disturbing influence of a variable and badly defined ignition is avoided.

SNPE, batch number: TL22/88). In the course of the experimental programme it was decided to use a narrower particle size distribution width by sieving the raw material. After a number of experiments with the original composition, experiments were carried out with only a sieved fraction with a diameter smaller than 710 μm . In later experiments still narrower particle size distribution widths were selected by sieving the material twice. In this way fractions were obtained with particle sizes between 600 and 710 μm and between 850 and 1000 μm . Experiments were performed with three different material densities: 1.28 mg/mm^3 , 1.35 mg/mm^3 and 1.42 mg/mm^3 .

2.5 Description of the measuring method

To register the position of the flame front, ionization probes are used, the tips of which are positioned on the axis of the tube (see Figure 1). The probes were obtained from Dynasen Inc. (type number CA-1207, length 2"). The probes are inserted into the tube through 1 mm diameter holes in the wall of the tube. They are isolated from the metal wall by a Teflon tube with an inner diameter of 0.65 mm and an outer diameter of 1 mm. The two conductors of the probes have a difference in voltage of 100 V. The change in voltage, due to the short circuiting of the two conductors by the influence of the ionized gases near the reaction front, is passed to a trigger unit that triggers one of the channels of a multichannel transient recorder (Krenz TRC 6070, sample frequency 20 MHz). The signal from the optical fibre in the ignition system is, after conversion to an electrical signal, also registered by the transient recorder and serves as a trigger signal.

A number of experiments were carried out in which one or two optical fibres were used at certain locations instead of ionization probes. This was in order to compare the outcome of these different kinds of probes and to find out how the output of the probes should be interpreted.

After each experiment the remains of the test-tube were gathered and examined and they served as an extra means of evaluating the result of the test.

3 EXPERIMENTAL RESULTS

3.1 Chronological overview

The current experimental programme started in 1987. After performing a number of try-out experiments, in which especially the construction of the igniter system was adjusted, the programme started with a series of experiments in which a tube with dimensions 15.9 mm inner diameter, 33.4 mm outer diameter and 200 mm length was used. In the first tests, explosive composition I was used, but later a switch was made to composition II. Later again, a sieved fraction of this composition ($d_p < 710 \mu\text{m}$) was used. Initially, pyrotechnic mixture I (producing mainly gaseous reaction products) was used to ignite the explosive, while in later experiments a switch was made to mixture II (producing mainly hot particles). An overview of this series of experiments can be found in Table 2.

A second series of experiments was performed with a larger tube (inner diameter = 36.2 mm, outer diameter = 64 mm, length = 327 mm). In this series, explosive composition II was used, and both experiments with the full composition and with a sieved fraction were performed. In each experiment, igniter I was used. Table 3 gives an overview of this series.

In the previously described series, only ionization probes were used to monitor the progress of the reaction front. In series III, a combination of ionization probes and optical fibres was installed to compare the output of both types of probe. These experiments were again performed in the tube used in test series I with the sieved fraction of composition II ($d_p < 710 \mu\text{m}$) as explosive material and with igniter II (see Table 4).

After that, a new test series with the tube of test series II was carried out, but this time with two fractions of composition II with a narrower particle size distribution width ($600 \mu\text{m} < d_p < 710 \mu\text{m}$ and $850 \mu\text{m} < d_p < 1000 \mu\text{m}$). Igniter system II was used and only ionization probes were applied (see Table 5).

In test series V, a new tube configuration was used. In this case the tube dimensions were: inner diameter = 28.2 mm, outer diameter = 54 mm, length = 358 mm. Experiments were performed with two narrow fractions of explosive composition II. In this series, two different explosive densities were used (1.28 mg/mm^3 and 1.35 mg/mm^3). In all experiments, igniter system II was applied (Table 6).

The last test series (VI) performed up to now used a tube geometry similar to the geometry used in series I and III but with a longer length (inner diameter = 16.2 mm, outer diameter = 34 mm, length = 334 mm). Again the two narrow fractions of explosive composition II were used ($600 \mu\text{m} <$

$d_p < 710 \mu\text{m}$ and $850 \mu\text{m} < d_p < 1000 \mu\text{m}$), but in this case three different densities were tested (1.28 mg/mm^3 , 1.35 mg/mm^3 and 1.42 mg/mm^3). Again igniter II was applied (Table 7).

3.2 Description of the results

In test series I, the results showed a rather large dependence on the measurement set-up (see Table 2). The first five experiments performed with the fine-grained composition I and the gas-producing igniter system I show a rather constant picture (see Figure 3).

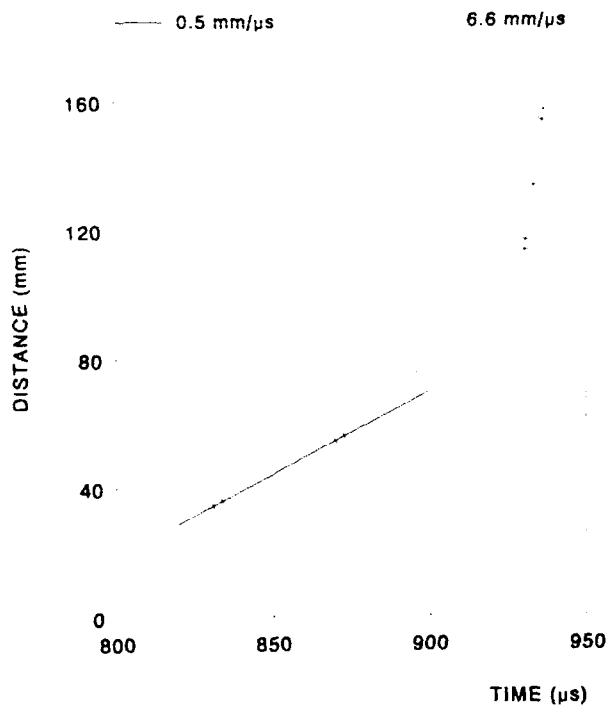

Figure 3 Response times of ionization probes in experiment no. 4 from test series I (tube geometry: inner diameter = 15.9 mm, outer diameter = 33.4 mm, length = 200 mm)

The flame front needs approximately $800 \mu\text{s}$ (except for one case where $1600 \mu\text{s}$ is needed) to reach the first ionization probe. From this time on we will refer to this period of time as the "ignition time". In the first part of the tube, the convective combustion front proceeds with a rather constant velocity in the order of $0.5 \text{ mm}/\mu\text{s}$. At approximately 70 to 110 mm from the igniter, an acceleration to a velocity of about $1 \text{ mm}/\mu\text{s}$ sets in and at a distance of 105 to 135 mm transits into a detonation with a velocity of over $6 \text{ mm}/\mu\text{s}$. One experiment however failed to show a transition; here the flame front showed a rather constant velocity of $0.7 \text{ mm}/\mu\text{s}$.

Table 2 Overview of test series I

experiment number	explosive composition	fraction (μm)	igniter system	density (mg/mm^3)	ignition time (ms)	detonation distance (mm)**
1	I	full	I*	1.276	1.60	120
2	I	full	I*	1.282	0.79	-
3	I	full	I*	1.277	0.86	115
4	I	full	I	1.275	0.84	105
5	I	full	I	1.277	0.69	135
6	II	full	I	1.370	1.13	-
7	II	full	I	1.366	1.49	-
8	II	full	I	1.295	1.22	-
9	II	< 710	I	1.275	1.40	-
10	II	full	I	1.300	1.41	-
11	II	< 710	I	1.264	1.04	-
12	II	< 710	I	1.300	1.36	-
13	II	< 710	II	1.260	3.40	-
14	II	< 710	II	1.280	1.54	-
15	II	< 710	II	1.278	-	-
17	II	< 710	II	1.281	207.44	-

* 180 mg of pyrotechnic mixture was used instead of 90 mg

** in this column, - means that no detonation was reached

In the next seven experiments, composition II was used instead of composition I. Both experiments with the full composition and with a sieved fraction were carried out. In contrast to the earlier experiments, no transition to detonation occurred. Initially the speed of the flame front was approximately $0.4 \text{ mm}/\mu\text{s}$ which later accelerated to approximately $1 \text{ mm}/\mu\text{s}$ but showed no further acceleration. The ignition time was also longer than before, about 1.3 ms. In the last four experiments of this test series, igniter system I was replaced by igniter II, which supplies mainly hot particles. In all experiments, the sieved fraction of composition II was used. From experiment no. 15 on, new pressing equipment was used with which the density of the explosive material could be adjusted more precisely. Also in these experiments, no detonation was reached, although in the last part of the tube, higher velocities were reached (up to $3 \text{ mm}/\mu\text{s}$) than in the previously described

experiments. In these experiments the ignition time fluctuated considerably (from 1.5 ms to 207 ms).

Although in the above experiments the ionization probe data showed no sign of a transition to detonation, from the fragments of the tube it could be observed that in about half of the experiments a detonation was still reached in the last part of the tube. Apparently a steep transition to detonation occurred in the relatively strongly confined final part of the tube where the tube wall is reinforced by the screw cap.

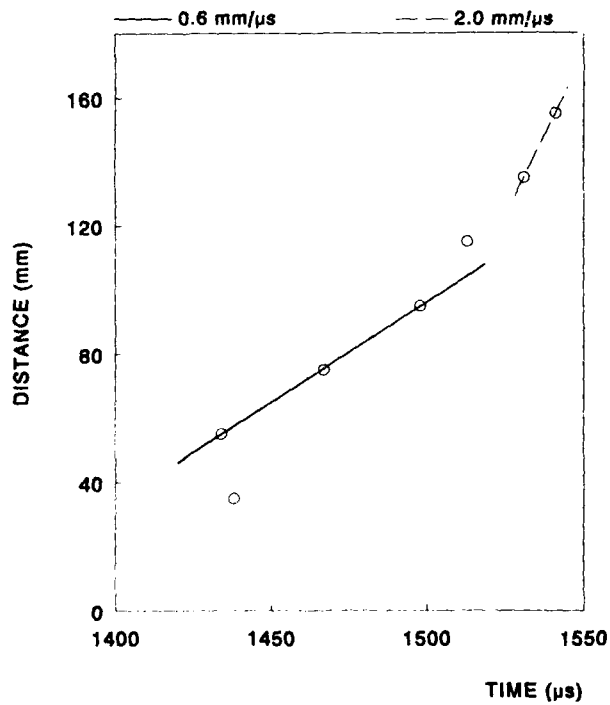

Figure 4 Response times of ionization probes in experiment no. 10 from test series I (tube geometry: inner diameter = 15.9 mm, outer diameter = 33.4 mm, length = 200 mm)

Another phenomenon that occurred in many of the experiments described above is that often the trigger time of the first probe was rather late compared with the response times of the other probes. Figure 4 gives a clear example of this phenomenon in which the first probe responds even later than the second one. Sometimes one of the other probes also showed this phenomenon.

Table 3 Overview of test series II

experiment number	explosive composition	fraction (μm)	igniter system	density (mg/mm^3)	ignition time (ms)	detonation distance (mm)
18	II	< 710	I	1.278	-	160
19	II	< 710	I	1.269	0.98	155
20	II	full	I	1.279	1.30	200
21	II	full	I	1.281	1.03	> 240
22	II	< 710	I	1.280	1.28	140
23	II	< 710	I	1.280	0.07	155

Test series II was performed with a much larger test-tube. This provided a larger confinement to the explosive material and because of its greater length gave more opportunity to transit to detonation. As a consequence, a transition to a detonation occurred in all experiments in contrast to the comparable experiments in test series I where no detonation transition was observed.

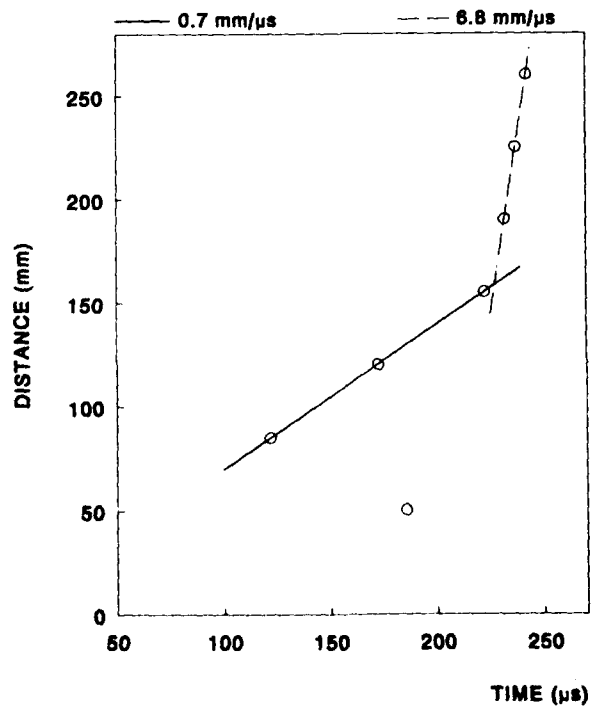

Figure 5 Response times of ionization probes in experiment no. 23 from test series II (tube geometry: inner diameter = 36.2 mm, outer diameter = 64 mm, length = 327 mm)

A typical example is given in Figure 5, showing the result of an experiment performed with sieved material. Initially a convective combustion is observed with an almost constant velocity in the order of $0.6 \text{ mm}/\mu\text{s}$. At 140 to 160 mm from the igniter, a sudden transition to a full detonation occurs. In this respect, a clear difference was observed when comparing the experiments performed with the sieved fraction with those performed with the complete composition. In the latter case, the convective combustion stage has a much longer duration than in the former case. The speed of propagation is not as constant but instead shows a smooth acceleration with a speed varying between $0.3 \text{ mm}/\mu\text{s}$ and $0.9 \text{ mm}/\mu\text{s}$. The final transition to detonation only occurs 200 mm to 250 mm from the igniter system (see Figure 6).

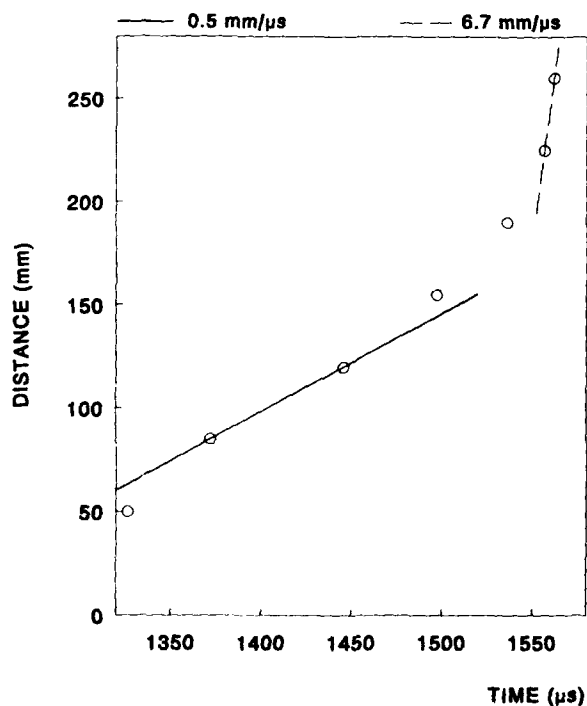

Figure 6 Response times of ionization probes in experiment no. 20 from test series II (tube geometry: inner diameter = 36.2 mm, outer diameter = 64 mm, length = 327 mm)

In this series, the response time of the first probe is often later than expected. The ignition time in most cases lies between 1000 and 1300 μs , which is comparable to the results obtained in test series I with the same igniter (igniter I). In one case however, an ignition time of 70 μs was observed, while in another case the signal from the fibre in the igniter system arrived later than the signals from the ionization probes. In the latter case however, there must have clearly been something wrong either with the location of the optical fibre or with the electronic detector system.

Table 4 Overview of test series III

experiment number	explosive composition	fraction (μm)	igniter system	density (mg/mm^3)	ignition time (ms)	detonation distance (mm)
24	II	< 710	II	1.274	24.64	-
25	II	< 710	II	1.282	37.94	-
26	II	< 710	II	1.295	30.15	>135
27	II	< 710	II	1.293	2.11	-
28	II	< 710	II	1.288	35.90	-
29	II	< 710	II	1.283	38.17	-

The purpose of test series III was to compare the response times obtained with the ionization probes with the response times obtained when an optical fibre detection system is used. The fibres instead of an ionization probe were inserted into holes in the wall of the tube. Their ends were kept flush with the inside wall of the tube and did not extend to the centre of the tube, as was the case with the ionization probes, because of the fragility of the fibres. Two tests were performed with only ionization probes to serve as reference experiments. In two other tests, two ionization probes 75 and 115 mm, respectively, from the igniter were replaced by optical fibres. In the last two measurements, one ionization probe 95 mm from the igniter was replaced by a fibre. In the latter case, the experiments also served as a test for an optical fibre temperature measuring system which is under development at PML. This report will not digress upon this fibre optic thermometer; the difference between the fibre system used for the thermometer and the fibre system used in the other case mainly lies in the detector system and is not relevant to this report.

In this test series, the test-tube from test series I was used. The other parameters were chosen equal to the last part of that test series (igniter II, sieved fraction of composition II, see Table 4). The results obtained from the ionization probes were therefore comparable to the results of these earlier tests. No full detonation is reached but in most experiments an acceleration to a velocity of 2 to 5 mm/ μs is observed in the last part of the tube. The ignition time varies between 2 and 40 ms.

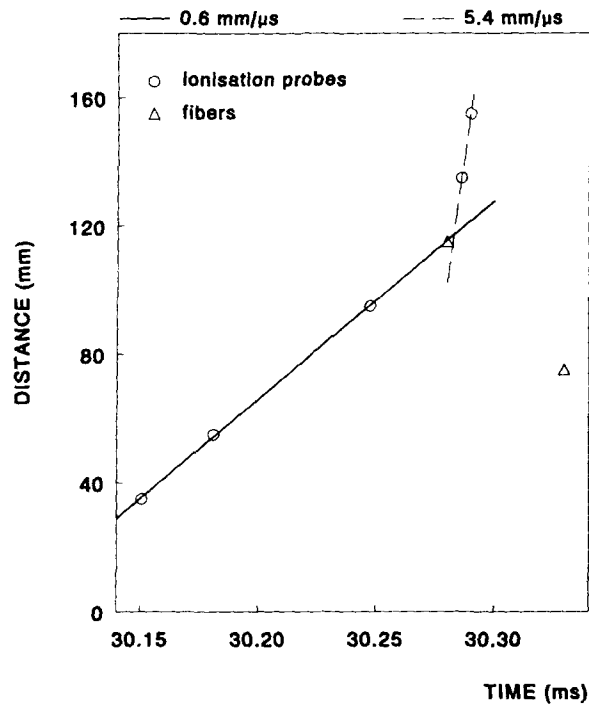

Figure 7 Response times of ionization probes and fibres in experiment no. 26 from test series III (tube geometry: inner diameter = 15.9 mm, outer diameter = 33.4 mm, length= 200 mm)

In Figure 7, an example is given of an experiment where two optical fibres were used instead of ionization probes at two locations. In this experiment, one fibre responds at the time expected from the response times of the ionization probes but the response time of the other is 115 μ s later than expected. The latter is typical of the results obtained with the fibres which tend to respond more than 100 μ s later than the ionization probes. We will come back to this subject again in section 4.2.

Table 5 Overview of test series IV

experiment number	explosive composition	fraction (μ m)	igniter system	density (mg/mm^3)	ignition time (ms)	detonation distance (mm)
32	II	850-1000	II	1.282	3206	175
33	II	850-1000	II	1.283	1031	215
34	II	600- 710	II	1.283	763	125
35	II	600- 710	II	1.281	-	150

Test series IV again made use of the test-tube geometry used in test series II. One of the differences is that in all experiments, igniter II was used instead of igniter I. Another important difference is that from this series on, a narrower particle size distribution width was used in the experiments. In these experiments two fractions were used, one with particle sizes between 600 μm and 710 μm and one with particle sizes between 850 μm and 1000 μm (see Table 5). Only ionization probes were used as measuring instruments. As expected, a transition to detonation occurred in all experiments. Again the transition occurred earlier for smaller particle sizes (125 - 150 mm) than for larger sizes (175 - 215 mm). The ignition time was extremely long and varied between 0.8 s and 3.2 s. In one case this time period could not be measured since the fibre optic probe failed. In Figure 8 an example is given of two experiments with both particle size fractions.

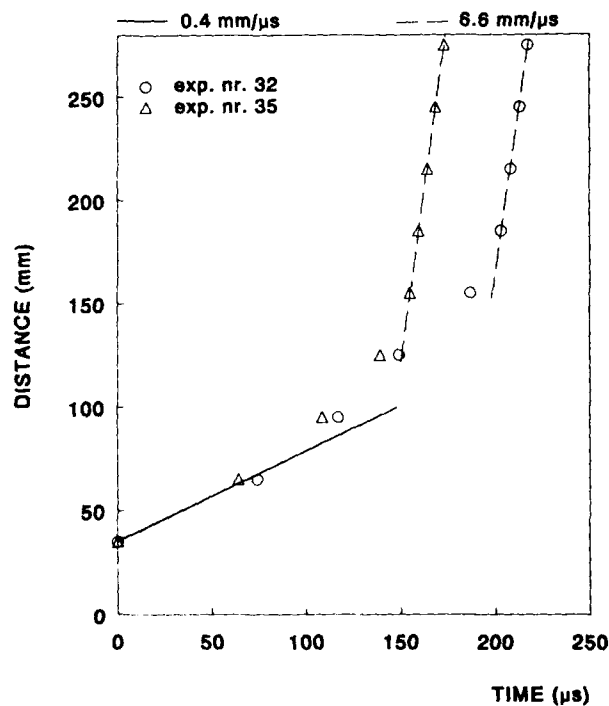

Figure 8 Response times of ionization probes in experiments no. 32 and no. 35 from test series IV (tube geometry: inner diameter = 36.2 mm, outer diameter = 64 mm, length = 327 mm)

In respect of the large difference in time frame, all times in this figure are taken relative to the response time of the first probe.

Table 6 Overview of test series V

experiment number	explosive composition	fraction (μm)	igniter system	density (mg/mm^3)	ignition time (ms)	detonation distance (mm)
36	II	600 - 710	II	1.280	-	150
37	II	600 - 710	II	1.279	0.3	125
38	II	600 - 710	II	1.278	0.3	125
39	II	850 - 1000	II	1.280	1201	195
40	II	850 - 1000	II	1.280	937	185
41	II	850 - 1000	II	1.274	1232	190
42	II	600 - 710	II	1.350	41.6	230
43	II	600 - 710	II	1.350	1.3	120
44	II	600 - 710	II	1.351	0.6	195
45	II	850 - 1000	II	1.350	421	160
46	II	850 - 1000	II	1.349	360	160
47	II	850 - 1000	II	1.348	371	145

Test series V comprised the use of a new tube geometry between the two types used earlier. Also from this test series on, the igniter system was revised in order to reduce the large fluctuations in ignition time observed previously when igniter II was used. In this case two different densities of explosive composition II were tested, and of each density, again two fractions of the particle size distribution.

The revision of the igniter system did not succeed in stabilizing the ignition time as can be seen from Table 6. It is however clear that the ignition time is much longer for larger particle sizes than for smaller particles. The data are too largely scattered to draw definitive conclusions about the influence of the material density, but it looks as if a density increase has a different influence for different particle sizes. Increasing the density has the effect of increasing both the ignition time and the detonation distance for a particle size of 600 - 710 μm , while the opposite is true for a particle size of 850 - 1000 μm . For a density of 1.28 mg/mm^3 , both the ignition time and the detonation distance are shorter for smaller particle sizes, while for a density of 1.35 mg/mm^3 this only holds for the ignition time. The detonation distance on the other hand is now larger for smaller particles. From the table it appears that the reproducibility of the experiments is not unreasonable, except for the experiments with a density of 1.35 mg/mm^3 and a particle size between 600 and 710 μm where a rather large scatter of the results occurs, both in ignition time and in detonation distance.

In some of the experiments the data suggest the presence of an intermediate stage between the convective burning stage and the detonation stage. In this intermediate stage the flame front velocity only slowly increases with a velocity in the order of 1 mm/ μ s until a sudden transition to detonation occurs. Figure 9 gives an example of such an experiment. On several occasions in this test series the response time of one of the first probes was not in line with the response times of the other probes.

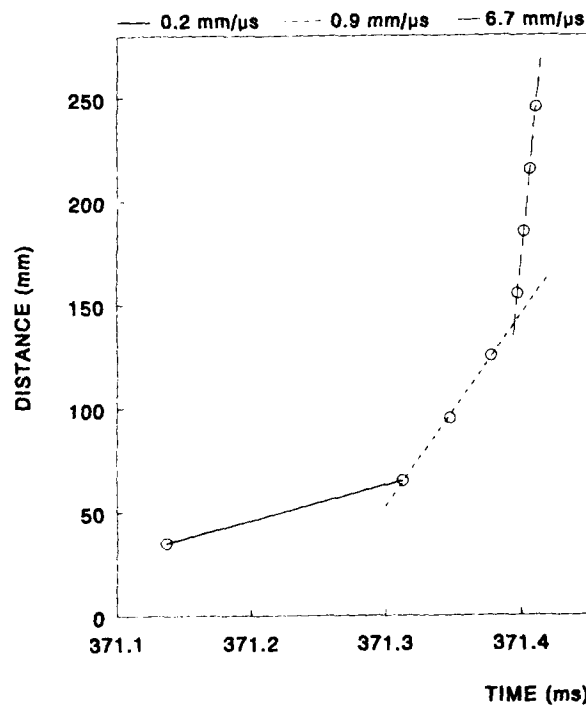

Figure 9 Response times of ionization probes in experiment no. 47 from test series V (tube geometry: inner diameter = 28.2 mm, outer diameter = 54 mm, length = 358 mm)

In test series VI a reversion was made to the small, relatively thin-walled tube used earlier in test series I and III. However the length of the tube was longer in order to be able to also measure long run-up lengths. Igniter type II was used which in test series I had not been able to bring about a transition to detonation within the relatively short length of the tube in that test series. In the current test series, three different explosive densities were tested, each for two different particle size fractions (see Table 7).

The scatter again appeared to be very large and is too large to draw conclusions about its dependency on density and particle size. It appeared to be difficult to reach a full detonation in this tube geometry. In many experiments, no detonation speed was observed by the ionization probes and in the experiments where a detonation was observed, it usually occurred close to the end of the tube. In general, the tests carried out with the 600 - 710 μ m particle fraction showed a greater tendency to

a transition to detonation while the detonation distance seemed to be slightly shorter for lower densities. In the experiments with the 850 - 1000 μm fraction, only occasionally was a full transition to detonation observed.

Table 7 Overview of test series VI

experiment number	explosive composition	fraction (μm)	igniter system	density (mg/mm^3)	ignition time (ms)	detonation distance (mm)
54	II	600 - 710	II	1.280	3.5	240
55	II	600 - 710	II	1.277	51.5	220
56	II	600 - 710	II	1.277	4.5	-
57	II	850 - 1000	II	1.278	110.7	-
58	II	850 - 1000	II	1.278	8.0	240
59	II	850 - 1000	II	1.277	1.5	-
48	II	600 - 710	II	1.350	8.1	-
49	II	600 - 710	II	1.349	0.3	240
50	II	600 - 710	II	1.348	0.4	230
51	II	850 - 1000	II	1.349	5.6	-
52	II	850 - 1000	II	1.347	3.1	-
53	II	850 - 1000	II	1.348	2.1	-
60	II	600 - 710	II	1.420	1.3	250
61	II	600 - 710	II	1.419	0.9	250
62	II	600 - 710	II	1.418	1.8	260
63	II	850 - 1000	II	1.418	6.5	-
64	II	850 - 1000	II	1.421	6.1	-
65*	II	850 - 1000	II	1.421	1.6	-
66**	II	850 - 1000	II	1.419	-	-

* no filling piece used in last part of tube

** PVC filling piece used instead of steel filling piece

The analysis of the remains of the test-tubes revealed a remarkable fact. In nearly all experiments, the tubes showed two large bulges at approximately the same places. In the part of the tube between the two bulges, the deformation of the tube is relatively small (see Figure 10). The final transition to detonation only takes place at a location between the second bulge and the end of the tube. It

therefore appears that the relatively low confinement of this geometry has a very large effect on the transition to detonation.



Figure 10 Remnants of test-tube after experiment no. 48 of test series VI

In most experiments, the filling piece contained in the end screw cap was recovered relatively intact. At the front of the filling piece, an imprint of the grain structure could be seen. This is also the case in experiments where no detonation was reached. In some experiments a small amount of unreacted explosive material was even recovered from the end part of the tube.

4 DISCUSSION

4.1 General

The general picture of the DDT experiments, described in the previous sections, conforms to results in other laboratories (see references 1, 5-7). The slow combustion, generated in the explosive by the igniter system, gradually increases its speed to a velocity in the order of 1 to 2 mm/ μ s and then suddenly transforms into a full detonation. This picture especially applies when the experiments are carried out in a thick-walled tube, but the phenomena appearing in a relatively thin-walled tube have a more complex nature. Another important factor is the initial stage of the DDT process. Although great pains have been taken to make the igniter system as well defined as possible, it still appears that the initial combustion stage is not yet well enough under control. This makes it difficult to draw definitive conclusions about the influence of other parameters that were varied in the experiments such as the density and the particle size distribution. Nevertheless, the combined results from the experiments performed already give clear hints to what kind of processes occur in the DDT process.

4.2 The interpretation of the signals obtained from the measuring probes

In the interpretation of the experimental results, one should take into careful consideration which value one should attach to the electrical signals obtained from the measuring probes. The ionization probes respond to a certain degree of gas ionization around the tip of the probe and it is known that they reliably detect the arrival of higher order reaction fronts. However, it is not certain that they respond timely to the arrival of a low order reaction front, and a lack of sensitivity to a low-order combustion is therefore one of the possible explanations for the often late response times of the first probes. One should also be aware that it is possible in theory that the probes are triggered by a strong shock wave propagating ahead of the flame front. It is, however, not very likely that this type of response played an important role in the experiments described here.

In test series III, a comparison was made between the response of the ionization probes and the response of optical fibres. Usually the fibres responded more than 100 μ s later than should be expected from the response times of the ionization probes. No explanation can be found as yet for these results and more investigations will be needed to further clarify these observations. In spite of the possibility of the improper functioning of the ionization probes, it appears from all the measurements that the response of the probes relative to each other is relatively reliable, except for a

small number of probes located in the front of the tube. Therefore we can still draw conclusions from the experimental results although we should always bear in mind that the principal measuring method might not be reliable in all cases. Another experimental method that was used in the interpretation of the experiments is an analysis of the tube fragments. This can be a useful addition to the results obtained from the probes and it appeared to be of crucial importance in the analysis of the results of test series VI (see section 4.5).

4.3 The influence of the igniter system and of density fluctuations in the explosive material

In the whole range of experiments, much effort has been put into generating a soft and very well-defined ignition for the explosive. Although this has certainly had a positive influence on the reproducibility and stability of the experiments, there still remained large differences between the ignition times, i.e. the time needed for the flame front to reach the first probe. A possible explanation is that this is the result of density fluctuations of the explosive material in the first part of the tube which are due to the method of filling used (see section 2.2). To avoid this effect in future experiments therefore, a different method will be used. However, it is not to be expected that this will completely eliminate the variations in ignition time. The main reason has probably to be looked for in the nature of the convective combustion process itself, where the flame front propagates as a result of the penetration of the hot reaction products into the unburned material and the subsequent ignition of the material. This process very much depends on the local geometry of the grain bed and will therefore always show relatively large fluctuations.

The strength of the ignition certainly appeared to have a large influence on the transition to detonation. In test series I, it appeared that in certain circumstances, a detonation could not be reached when igniter II was used, while it could when igniter I was used which produced a much larger amount of gaseous reaction products. With a stronger ignition, a further stage in the DDT process can be reached immediately, causing the following stages to occur earlier in the tube.

4.4 The influence of particle size and density

From all the experiments performed with a density of 1.28 mg/mm^3 , it can be clearly concluded that a smaller averaged particle size leads to a shorter detonation distance. This is both true for the experiments where a sieved fraction was compared with the original material, and for the experiments where two fractions with a relatively narrow distribution width were compared. The explanation for this dependency might be that the penetrability of the explosive bed is smaller for small particles, providing a larger confinement for the gaseous reaction products which leads to a higher pressure at the combustion front and therefore to an earlier acceleration of the burning

process. However, such a tendency could not be seen in the experiments in test series V, performed with a density of 1.35 mg/mm^3 . Although the scatter in the results is rather high in the experiments performed with the 600 - 710 μm fraction, it still looks as if the detonation distance decreases rather than increases for a larger particle size. How this observation should be explained is not yet clear. One possible explanation might be that for higher densities, a small particle size unfavourably influences the threshold value for shock initiation, which is the final stage in a DDT process. This again emphasizes that in a DDT, a number of different processes occur that depend in a different way on various parameters.

When viewed from another angle, it could also be concluded from the experiments of test series V that the influence on the detonation distance of a density increase is different for a particle size of 610 - 710 μm than for a particle size of 850 - 1000 μm . The results for test series VI are not clear enough to confirm this observation. More experiments will be needed to provide a better base for developing a theoretical explanation for the obtained results.

From the measurements in test series V, it could be concluded that increasing the particle size has the effect of increasing the ignition time. An explanation for this effect is that smaller particles provide a larger burning surface and therefore a higher burn rate in the first stage of the burning process. On the other hand, a smaller particle size presents a larger resistance to convective combustion and has a retarding influence on this type of burning process. Which effect dominates probably depends on a number of different parameters, leading to a different result in different circumstances. This might agree with the results of the other test series where a clear dependency on the particle size could not be observed.

The experiments of test series V also showed that an increase in the density increases the ignition time for particle sizes between 600 μm and 710 μm , while it decreases the ignition time for particle sizes between 850 μm and 1000 μm . Again this seems to indicate that different and opposite effects are at work, where the specific circumstances determine which effect dominates in a specific case. From all the experiments it can be concluded that the ignition time is longer for larger values of the inner diameter of the tube. This effect however is to be expected in view of the decreasing ratio of the igniter surface to the cross-sectional surface of the explosive material for an increasing value of the inner diameter of the tube.

4.5 The influence of the confinement

A clear and reasonably reproducible transition to detonation has only been observed in experiments with thick-walled tubes. In the experiments with the relatively thin-walled tubes, a transition often did not occur or only occurred very late in the tube, even if the other circumstances were equal to those with the thick-walled tubes. A certain level of confinement is clearly necessary in order to invoke the final acceleration to detonation. However, what is actually happening in the case of a relatively low confinement is not yet clear. From the analysis of the tube fragments in test series VI however, a certain picture puts itself forward. The tubes appear to reach their largest expansion at two points, while in between, a region with rather low deformation is found. This indicates that the pressure of the reaction products has reached much higher values in those areas than in the area in between. An explanation for this peculiar phenomenon might be that in the region with low deformation, a so-called "plug" has formed, i.e. a region where the explosive material has been compressed to a density of almost 100% TMD, where no convective combustion can take place and where the explosive burns relatively slowly in conductive mode. The formation of such "plugs" has been observed earlier in other experiments (see reference 11) and has also been predicted by numerical modelling of the DDT process (see reference 4). In this view the explosive material in front of the plug cannot sufficiently vent its product gases and consequently quickly builds up a very high pressure which causes large deformation and fracture of the tube. The material behind the plug is ignited by a compressive combustion wave travelling through the plug and the build-up process repeats itself. The fact that, in many experiments, a final transition to detonation is observed close to the end of the tube can be ascribed to the relatively larger tube strength in this region due to the end screw caps.

5 FURTHER DEVELOPMENTS

In the experiments performed, a number of interesting phenomena has been observed. From these observations some tentative conclusions about the nature of the DDT process have been drawn. However, in order to be able to get rid of some disturbing circumstances, the set-up of the experiment will have to be further improved. One of the disturbing influences is the large irreproducibility of the initial burning stage. One of the possible reasons for this behaviour is a non-uniform density of the explosive material in the region near the igniter, due to the method of preparation of the charge. To eliminate these inhomogeneities in future experiments, a slightly different filling method will be used by which the inhomogeneities will be strongly reduced.

The often irregular responses of the ionization probes in the combustion stages of the DDT process might on the one hand be the result of the formation of plugs, but on the other hand could be the result of an improper functioning of the probes in these low-order stages. To further investigate this latter possibility, new experiments will be performed that will be partly instrumented with optical fibres.

The systematic research on the dependence of the DDT process on variables such as density, particle size and explosive composition will be continued, mainly with thick-walled tubes in order to avoid the results of these experiments becoming obscured by the effects of a low confinement.

Also, the research into the influence of the confinement will be continued, in view of the very interesting results obtained with the relatively thin-walled tube. In this respect, experiments are also planned with a small tube with the same inner diameter as the mentioned thin-walled tube but with a thicker wall.

6 CONCLUSION

In the experimental DDT programme at PML, special care has been taken to make the experiments as well defined and reproducible as possible. Although these efforts have certainly had a positive influence, an optimum has not yet been reached but further improvement of the experimental set-up is certainly still possible. Although the desired level of reproducibility has not yet been reached, interesting observations have been made during the experiments. Especially the observations on the influence of the confinement on the DDT process are very interesting and make further investigations into this point very worthwhile.

7 AUTHENTICATION

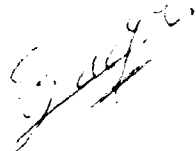

E.G. de Jong
(Author)



R. Oostdam
(Author)



H.J. Verbeek
(Author)

8 REFERENCES

- 1 Bernecker, R.R. and Price, D.
Studies on the Transition from Deflagration to Detonation, *Combust. Flame* 22, 1974, 111-118, 119-129, 161-170.
- 2 Verbeek, H.J.
Modelling of DDT in Granular Explosives, *Proc. Eighth Symp. (Int.) on Detonation*, 1985, 669-677.
- 3 Verbeek, H.J.
The Development of a Numerical Model for the Simulation of DDT in Granular Explosive Materials, PML Report, PML 1986-49.
- 4 Verbeek, H.J.; Steen, A.C. van der
Combined Experimental and Theoretical Investigations into the Deflagration to Detonation Transition, *Proc. Ninth Symp. (Int.) on Detonation*, 1989, 320-328.
- 5 Samirant, M.
Deflagration to Detonation Transition in Waxed RDX, *Proc. Seventh Symp. (Int.) on Detonation*, 1981, 139-142.
- 6 Samirant, M.
DDT in RDX and Ball Powder: Behaviour of the Porous Bed, *Proc. Eighth Symp. (Int.) on Detonation*, 1985, 972-976.
- 7 Samirant, M.
DDT - Determination of the Successive Phases of Phenomena, *Proc. Ninth Symp. (Int.) on Detonation*, 1989, 259-264.
- 8 Verbeek, H.J. and Steen, A.C. van der
Linking Experimental and Theoretical Results on the Deflagration to Detonation Transition, *Prop. Expl. Pyr.* 15, 1990, 35-37.

- 9 Verbeek, H.J. and Steen, A.C. van der
Combined Experimental and Theoretical Investigations into the Deflagration to Detonation
Transition, Proc. 4th Int. Conf. of the GTP, 1989, 61-67
- 10 Oostdam, R.; Jong, E.G. de; Verbeek, H.J.
DDT experimenten in relatief dunwandige buizen, PML rapport, PML 1992-106
- 11 McAfee, J.M.; Asay, B.W.; Campbell, A.W.; Ramsay, J.B.
Deflagration to Detonation in Granular HMX, Proc. Ninth Symp. (Int.) on Detonation,
1989, 276-279.

REPORT DOCUMENTATION PAGE
(MOD NL)

1. DEFENSE REPORT NUMBER (MOD-NL) TD92-2743	2. RECIPIENT'S ACCESSION NUMBER	3. PERFORMING ORGANIZATION REPORT NUMBER PML1992-77
4. PROJECT/TASK/WORKUNIT NO. 221492020	5. CONTRACT NUMBER A80/KI/137	6. REPORT DATE January 1993
7. NUMBER OF PAGES 31	8. NUMBER OF REFERENCES 11	9. TYPE OF REPORT AND DATES COVERED Final
10. TITLE AND SUBTITLE Experimental Investigations into the Deflagration to Detonation Transition at TNO/PML (Het experimentele onderzoek naar de deflagratie naar detonatie overgang op PML/TNO)		
11. AUTHOR(S) H.J. Verbeek, R. Oostdam, E.G. de Jong		
12. PERFORMING ORGANIZATION NAME(S) AND ADDRESS(ES) TNO Prins Maurits Laboratory P.O. Box 45, 2280 AA Rijswijk, The Netherlands		
13. SPONSORING AGENCY NAME(S) AND ADDRESS(ES) DMKL, afdeling Munitie Postbus 90822, 2509 LV Den Haag		
14. SUPPLEMENTARY NOTES The classification designation: ONGERUBRICEERD is equivalent to: UNCLASSIFIED		
15. ABSTRACT (MAXIMUM 200 WORDS (1044 BYTE)) This report presents an overview of the experimental research that has been performed at TNO-PML from 1988 to 1991 on the subject of the transition from a deflagration to a detonation (DDT) in solid explosives. A full description is given of the set-up used for the experiments, of the development in time of the set-up and of the rationale for the applied changes. Among the experimental results that are presented, the influence on the DDT process is shown of variations in parameters such as the tube geometry, the explosive density, the particle size and the igniter strength. The results obtained at a relatively low wall thickness of the test-tube are particularly notable.		
16. DESCRIPTORS Experimental Investigations Explosives		IDENTIFIERS Deflagration-to-Detonation Transition Tube Test
17A. SECURITY CLASSIFICATION (OF REPORT) ONGERUBRICEERD	17B. SECURITY CLASSIFICATION (OF PAGE) ONGERUBRICEERD	17C. SECURITY CLASSIFICATION (OF ABSTRACT) ONGERUBRICEERD
18. DISTRIBUTION AVAILABILITY STATEMENT Unlimited Distribution		17D. SECURITY CLASSIFICATION (OF TITLES) ONGERUBRICEERD

Distributielijst

- 1 DWOO
- 2 HWO-KL
- 3/4 HWO-KLu
- 5 HWO-KM
- 6 Ministerie van Defensie, afdeling Munitie
J.A. van Gool
- 7/9 TDCK
- 10 Hoofddirecteur DO-TNO
- 11 Lid Instituuts Advies Raad PML
Prof. drs. P.J. van den Berg
- 12 Lid Instituuts Advies Raad PML
Prof. ir. M.A.W. Scheffelaar
- 13 Lid Instituuts Advies Raad PML
Prof. ir. H. Wittenberg
- 14 PML-TNO, Directeur; daarna reserve
- 15 PML-TNO, Directeur Programma; daarna reserve
- 16 PML-TNO, Documentatie
- 17 PML-TNO, Archief
- 18/29 Divisie 2, Eigenschappen Energetische Materialen
- 30 Dr. R.R. Bernecker, NSWC, USA
- 31 Dr. M. Samirant, ISL, France
- 32 Dr. M.R. Baer, Sandia National Laboratories, USA
- 33 Dr. J.M. McAfee, LANL, USA
- 34 Dr. P.B. Butler, University of Iowa, USA
- 35 Dr. R. Derr, NWC, USA
- 36 Dr. C. Belanger, DREV, Canada
- 37 Dr. P.J. Haskins, RARDE, UK
- 38 Dr. J.W.B. Crucq, Timberwolf Consulting Services, Middelburg