

AD-A267 139

132

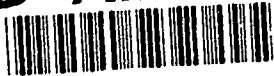

UMENTATION PAGE

Form Approved
OMB No. 0704-0188

DTIC
SELECTED
SCHEDULE 2 1993
S B D

1a. REPORT SECURITY CLASSIFICATION
UNCLASSIFIED

1b. RESTRICTIVE MARKINGS

2a. SECURITY CLASSIFICATION AUTHORITY

3. DISTRIBUTION / AVAILABILITY OF REPORT
Approved for public release;
distribution unlimited

2b. DECLASSIFICATION / DOWNGRADING SCHEDULE

4. PERFORMING ORGANIZATION REPORT NUMBER
Test Operations Procedure
(TOP) 6-2-040

5. MONITORING ORGANIZATION REPORT NUMBER(S)
Same as Item 4

6a. NAME OF PERFORMING ORGANIZATION
U.S. Army Electronic
Proving Ground

6b. OFFICE SYMBOL
(if applicable)
STEEP-MO

7a. NAME OF MONITORING ORGANIZATION
U.S. Army Test and Evaluation Command

6c. ADDRESS (City, State, and ZIP Code)
Fort Huachuca, AZ 85613-7110

7b. ADDRESS (City, State, and ZIP Code)
Aberdeen Proving Ground, MD 21005-5055

8a. NAME OF FUNDING / SPONSORING ORGANIZATION
Same as Item 7a

8b. OFFICE SYMBOL
(if applicable)
AMSIE CT T

9. PROCUREMENT INSTRUMENT IDENTIFICATION NUMBER

8c. ADDRESS (City, State, and ZIP Code)
Same as Item 7b

10 SOURCE OF FUNDING NUMBERS			
PROGRAM ELEMENT NO.	PROJECT NO.	TASK NO.	WORK UNIT ACCESSION NO.

11. TITLE (Include Security Classification)
"Non-Lethal Unmanned Aerial Vehicles (UAVs)" (U)

12. PERSONAL AUTHOR(S)

13a. TYPE OF REPORT
Final

13b. TIME COVERED
FROM _____ TO _____

14. DATE OF REPORT (Year, Month, Day)
1993 June 15

15. PAGE COUNT
41

16. SUPPLEMENTARY NOTATION
Non-Lethal Unmanned Aerial Vehicle (UAV) reflects current terminology. Remotely Piloted Vehicle (RPV) and Drone Aircraft are outdated terms.

17. COSAT: CODES		
FIELD	GROUP	SUB-GROUP

18. SUBJECT TERMS (Continue on reverse if necessary and identify by block number)
UAVs Flight Terminal
Payload FLIR Infrared

19. ABSTRACT (Continue on reverse if necessary and identify by block number)
This TOP describes testing methods for determining the technical characteristics of Non-Lethal Unmanned Aerial Vehicles (UAVs). It provides a general description of facilities, instrumentation, and tasks required. It also specifies the documentation required including safety, environmental, and frequency authorization documentation. In details methodology for measuring Center of Gravity, developing flight profiles, performing flight tests, and performing transportability tests. This TOP discusses in general Electromagnetic Environmental, Manpower Integration/Reliability, Availability, Maintainability (MANPRINT/RAM), and Aural/Visual/Acoustic testing.

93 7 21 023

93-16519



43,05

20. DISTRIBUTION / AVAILABILITY OF ABSTRACT
 UNCLASSIFIED/UNLIMITED SAME AS RPT DTIC USERS

21. ABSTRACT
UNCLASSIFIED

22a. NAME OF RESPONSIBLE INDIVIDUAL

22b. TELEPHONE (Include Area Code)

22c. OFFICE SYMBOL

US ARMY TEST AND EVALUATION COMMAND
TEST OPERATIONS PROCEDURE

*Test Operations Procedure (TOP) 6-2-040
AD No.

15 June 1993

Non-Lethal Unmanned Aerial Vehicles

	<u>Page</u>
Paragraph 1. SCOPE	1
2. FACILITIES AND INSTRUMENTATION.	1
2.1 Facilities.	1
2.2 Instrumentation	2
3. REQUIRED TEST CONDITIONS.	3
3.1 Facilities.	3
3.2 Test Documentation.	4
3.3 Instrumentation	10
3.4 Data Required	10
4. TEST PROCEDURES	11
4.1 Air Vehicle Weight and Center of Gravity Tests.	11
4.2 Support Vehicles/Trailers Weight and Center of Gravity Tests.	13
4.3 Air Vehicle Dimension Measurements.	16
4.4 Transportability Tests.	17
4.5 Emplacement/Displacement Tests.	17
4.6 Flight Tests.	18
4.7 Aural/Visual/Acoustic Tests	19
4.8 MANPRINT/RAM Tests.	20
5. PRESENTATION OF DATA.	20
APPENDIX A METEOROLOGICAL FORMS.	A-1
B DATA COLLECTION FORMS	B-1
C ACRONYMS LIST	C-1
D REFERENCES.	D-1

1. SCOPE. This TOP describes the procedures required to determine the technical characteristics, performance, and limitations of Non-Lethal Unmanned Aerial Vehicles (UAV). Specifically, these procedures include: the collection of flight performance data (e.g., dash speed, rate of climb, service ceiling); determining data link capability; recording the functionality of the avionics, Remote Video Terminals (RVTs), Ground Data Terminals (GDTs), and Ground Control Stations (GCSs); and determining the logistical characteristics of the UAV and ground support equipment (e.g., emplacement time, center of gravity measurements to assess ability to transport system equipment). This TOP does not detail Electromagnetic Environmental and Physical Characteristics testing which are common to most systems. The test engineer should consult the appropriate TOP for additional information.

2. FACILITIES AND INSTRUMENTATION.

*This TOP supersedes MTP 7-2-040, Drone Aircraft, 25 Mar 70.
Approval for public release; distribution unlimited.

2.1 Facilities. UAV systems require an adequate hangar facility to house the air vehicle and perform maintenance actions. The test engineer should pay close attention to the wing span dimension of the air vehicle when choosing a facility. Wherever possible, the test engineer should choose a facility that allows entrance and exit of the air vehicle without removal of the wings. In addition, the facility should provide access for the mobile Ground Control Stations (GCSs).

<u>Facility Requirement</u>	<u>Purpose</u>
Fuel/Chemical Storage	To ensure personnel safety.
Pyrotechnics Storage	To ensure personnel safety.
Launch/Recovery Area	To provide staging area and equipment set-up point. May be paved or unimproved, depending on test requirement.
Controlled Airspace	To provide flying area for UAV.
Real Estate (Preferably government-owned property)	To provide an emergency recovery area for UAV and space for ground targets.

2.2 Instrumentation.

<u>Devices for Measuring</u>	<u>Permissible Error of Measuring Device</u>
Tracking Radar or Laser and Space-Position plotting and recording	± 0.2 milliradians in Azimuth and Elevation ± 4.6 meters in Range
Range Timing (IRIG-B or equivalent)	± 2 microseconds
Still Photo and Video Recording of UAV, Support Equipment, Ground Control Station Displays, and Operator Actions (audio and video)	Quality determined by test requirement. All video must be annotated with range timing.
Scale or Load Cells	± 0.5 % of the total weight
Graduated Cylinder	± 1 milliliter
Measuring Tape	± 25 millimeter
Compass	± 1 degree

Restricted Airspace Area or Military Operating Area (MOA). Each installation has its own set of rules for their Restricted Airspace. Installations may require radar or laser tracking for flights beyond visual range and may also have altitude restrictions, but normally do not require chase aircraft. Consult your local Airspace Safety Officer for specific restrictions. For flights outside your installation's restricted airspace in MOAs or in-transit to MOAs, consult Federal Aviation Administration (FAA) Special Military Operations, 7610.4 G. The FAA requires chase aircraft, but does grant exemptions for special cases. The FAA usually requires an Identify Friend or Foe (IFF) transponder, a Flight Termination System (FTS), and radar tracking. Consult the FAA for specifics. The test engineer must obtain permission from the FAA to fly outside his/her installation's airspace well in advance of the mission. Depending on the amount of traffic in the area, obtaining airspace may be difficult. The test engineer should begin planning airspace requirements as early as possible.

f. Both target vehicles and emergency recovery operations require land area below the airspace in an unpopulated or sparsely populated area. Government property for any ground operations is desirable. If the government property is not owned by the installation performing the test, the test officer must obtain permission from the private owner, state agency or federal agency responsible for the land. Consult your local real estate manager to obtain the required permits and/or permission.

3.2 Test Documentation.

a. Strategy. The test engineer shall review the Test and Evaluation Master Plan (TEMP), the System Specification, and the Independent Evaluation Plan/Test Design Plan (IEP/TDP) to determine a strategy for providing the independent evaluator the information required for analysis. The test engineer must consult the appropriate support agencies within his/her organization for assistance in areas outside his/her expertise [e.g., Electromagnetic Interference/Compatibility (EMI/EMC), Manpower and Personnel Integration (MANPRINT) and Reliability, Availability, and Maintainability (RAM), Emplacement/Displacement, Aural/Visual]. This ensures that all test requirements are adequately addressed.

b. Mission Plan and Flight Profile. The test engineer shall develop mission plans which provide a step by step explanation of events and show the area of operation, operational altitude, time of events, duration, and waypoint coordinates. The test engineer shall also develop a flight profile which provides a map overlaid with the waypoints described in the mission plan. See Figure 1 for an example of a mission plan and Figure 2 for an example of a flight profile. The mission plan shall include the location of waypoints in Universal Transverse Mercator (UTM) or Latitude/Longitude coordinates. The test engineer must identify the datum for the coordinates (e.g., World Geodetic Survey 1984 (WGS 84), North American Datum 1927 (NAD 27)). Current technology prefers UTM coordinates with WGS 84 as the datum. If nighttime (low light level) conditions are required for evaluation of

TOP 6-2-040
15 June 1993

payload performance, the test engineer should consult the local Meteorological Office for forecasts (Appendix A, page A-2, provides sample Met forecasts) and adjust the time of events accordingly.

c. Target Plan. The test engineer shall develop a plan for target deployment and operation which meets the test requirements and coincides with the schedule outlined in the flight profile. Targets may consist of vehicles, personnel, and resolution boards. For vehicles and personnel, the plan shall describe for each mission the number of targets deployed, target locations, time on station, movement requirements, and any special instructions (e.g., camouflage, engines on for infrared sensors). For target resolution boards, the plan shall include the size, pattern, angle with respect to the ground and board type (i.e., day television or infrared). A drawing showing dimensions and orientation is desirable. In addition, the test engineer must ensure that all target locations are surveyed and included in the target plan. Locations are required to ensure the flight path covers the target area and for post-test analysis.

TOP 6-2-040
15 June 1993

FLIGHT #48							
SCENARIO # 1A							
		SENSOR	UAV	REVISION 6	10 JAN 92		
EVENT NUMBER	OBJECTIVE	DATA NUMBER	UPT NUMBER	UTM POSITION	ALT MSL METERS	TIME ZULU	TIME NST
1	CHECK NAVIGATION LIGHTS, C-BAND BEACON, AND UAV LAUNCH POSITION (NAVIGATION ACCURACY).	30,33	N/A	N/A	N/A	N/A	N/A
2	UPDATE LOST LINK WAY POINT FILE FOR WEST RANGE E: 555500 ALTITUDE 2200m RSL N:3496000	N/A	N/A	N/A	N/A	N/A	N/A
3	LAUNCH FROM UNPAVED RUNWAY	28,31	0	N/A	N/A	0900	0200
4	HAND-OFF UAV CONTROL FROM EPC TO LRS	29,37 31	N/A	N/A	N/A	0914	0214
5	TRANSIT TO WP 1 FOLLOWING AV CHECKS. HAND-OFF UAV CONTROL FROM LRS TO GCS #1.	29,37 31	1	E: 553500 N:3500000	1700	0915	0215
6	TRANSIT TO WP 2. DURING TRANSIT, STAGE UNAIDED NAVIGATION MODE FOR 10 MINUTES.	33	2	E: 546950 N:3493250	2200	0920	0220
7	TRANSIT TO WP 3.	33	3	E: 540312 N:3489406	2200	0924	0224
8	TRANSIT TO WP 4.	33	4	E: 530000 N:3490000	2200	0927	0227
9	END UNAIDED NAVIGATION MODE. CONDUCT FREQUENCY CHANGE. OBTAIN PAPA SAFETY'S APPROVAL TO PROCEED TO THE EAST RANGE.	33,32	4	E: 530000 N:3490000	2200	0931	0231
10	STAGE GO TO NAVIGATION MODE (GPS RECEIVER OFF) FOR 15 MINUTES. TRANSIT TO WP 5. DURING TRANSIT, CONDUCT LOW ALTITUDE SPEED TEST (MIN, MAX, CRUISE, LOITER) AT TO'S COMMAND.	33,39	5	E: 575000 N:3498750	2200	0933	0233
11	UPDATE LOST LINK WAY POINT FILE FOR EAST RANGE. E: 571000 ALTITUDE 2200 METERS RSL N:3501000	N/A	N/A	N/A	N/A	N/A	N/A
12	CONDUCT FREQUENCY CHANGE. OBTAIN PAPA SAFETY'S APPROVAL TO PROCEED TO THE WEST RANGE.	52	5	E: 575000 N:3498750	2200	0951	0251
13	STAGE GO TO NAVIGATION MODE (GPS RECEIVER OFF) FOR 15 MINUTES. TRANSIT TO WP 6. DURING TRANSIT, CONDUCT LOW ALTITUDE SPEED TEST (MIN, MAX, CRUISE, LOITER) AT TO'S COMMAND.	33,39	6	E: 530000 N:3490000	2200	0956	0256
14	UPDATE LOST LINK WAY POINT FILE FOR WEST RANGE. E: 535500 ALTITUDE 2600 METERS RSL N:3496000	N/A	N/A	N/A	N/A	N/A	N/A
15	TRANSIT TO WP 7.	N/A	7	E: 540838 N:3492230	2600	1014	0314
16	CONDUCT SEARCH OF AREA BOUNDED BY: E:540838 N:3492230 E:541008 N:3491978 E:543340 N:3493085 E:543505 N:3493435	46	7	E: 540838 N:3492230	3055	1019	0319
17	TRANSIT TO WP 8. DURING TRANSIT, PERFORM EMERGENCY LINK REACQUISITION TEST (DROP UPLINK AND DOWNLINK FOR 5 MINUTES, THEN REACQUIRE.)	33	8	E: 538000 N:3500000	2600	1049	0349
18	LOITER BETWEEN WP 8 AND WP 9. WHILE RELAY UAV LAUNCHES.	N/A	8	E: 538000 N:3500000	2600	1054	0354
19	HAND-OFF SENSOR UAV CONTROL FROM GCS #1 THROUGH RELAY UAV TO GCS #2.	37	8	E: 538000 N:3500000	2600	1127	0427
20	TRANSIT TO WP 9.	N/A	9	E: 530450 N:3491800	2600	1132	0432
21	CONDUCT SEARCH OF AREA BOUNDED BY: E:530450 N:3491800 E:531450 N:3491000 E:530450 N:3492000 E:531450 N:3492000	46	9	E: 530450 N:3491000	2572	1137	0437

Figure 1 (a). Example Mission Plan

FLIGHT #48							
SCENARIO # 1A							
		SENSOR	UAV	REVISION #	10 JAN 92		
EVENT NUMBER	OBJECTIVE	DATA NUMBER	MPT NUMBER	UTM POSITION	ALT MSL METERS	TIME ZULU	TIME MET
22	TRANSIT TO WP 10.	N/A	10	E: 542400 N:3493000	2900	1207	0507
23	DURING TRANSIT, UPDATE TO WP 11.	56	11	E: 533400 N:3497200	2900	1209	0509
24	CONDUCT TARGET LOCATION.	48	11	E: 533400 N:3497200	2877	1219	0514
25	HAND-OFF SENSOR UAV CONTROL FROM GCS #2 TO GCS #1	57	11	E: 533400 N:3497200	2000	1224	0524
26	TRANSIT TO WP 12. DURING TRANSIT, OBTAIN PAPA SAFETY'S APPROVAL TO PROCEED TO EAST RANGE.	N/A	12	E: 543000 N:3496300	2800	1229	0529
27	UPDATE LOST LINK WAY POINT FILE FOR EAST RANGE. E: 571000 ALTITUDE 2500m MSL N:3501000	N/A	N/A	N/A	N/A	N/A	N/A
28	HAND-OFF SENSOR UAV CONTROL FROM GCS #1 THROUGH RELAY UAV TO GCS #2	57	12	E: 543000 N:3496300	2800	1230	0530
29	TRANSIT TO WP 13. CLIMB TO 2920m MSL	N/A	13	E: 573327 N:3504892	2920	1235	0535
30	CONDUCT TWO HOUR TARGET BOARD DETECTION TEST FOLLOWING RACE TRACK CIRCUIT BOUNDED BY:	45	13	E: 573327 N:3504892	1300	0600	
				WP 13 E: 573327 N:3504892	ALT(M)AGL	NO. LAPS	
				WP 14 E: 572327 N:3504892	1900	1	
				WP 15 E: 573327 N:3495392	1800	1	
				WP 16 E: 574327 N:3495392	1600	1	
					1300	1	
					1000	2	
					800	2	
					600	2	
					400	1	
							NOTE: TARGET BOARD ALT 1320m MSL
							REPEAT ALTITUDES UNTIL TEST DIRECTOR DISCONTINUES THIS TEST. (NOTE: THIS IS SCHEDULED FOR 2 HOURS).
							NOTE: SWITCH FOV BETWEEN WP 13 & 14.
31	TRANSIT TO WP 17. DURING TRANSIT, CONDUCT FREQUENCY CHANGE.	52	17	E: 572115 N:3497205	2800	1300	0600
32	CONDUCT 15 MINUTE AUTONOMOUS SEARCH (FOLLOWED BY 15 MINUTE TRANSMISSION OF RECORDED VIDEO) OF AREA BOUNDED BY: E: 572115 N:3497205 E: 571115 N:3497205 E: 571115 N:3496205 E: 572115 N:3496205	52	17	E: 572115 N:3497205	2820	1302	0602
33	TRANSIT TO WP 18. DURING TRANSIT, CONDUCT FREQUENCY CHANGE.	52	18	E: 543000 N:3496300	2500	1332	0632
34	HAND-OFF SENSOR UAV CONTROL FROM GCS #2 TO GCS #1	57	18	E: 543000 N:3496300	2500	1333	0633
35	OBTAIN PAPA SAFETY'S APPROVAL TO PROCEED TO THE WEST RANGE. TRANSIT TO WP 19.	N/A	19	E: 540000 N:3496500	2200	1340	0640
36	UPDATE LOST LINK WAY POINT FILE FOR WEST RANGE. E: 533500 ALTITUDE 1800 METERS MSL N:3496000	N/A	N/A	N/A	N/A	N/A	N/A
37	TRANSIT TO WP 20. DESCEND TO 1800m MSL.	N/A	20	E: 533500 N:3308000	1800	1342	0642
38	LOITER AT WP 20. HAND-OFF SENSOR UAV CONTROL FROM GCS #1 TO LRS.	57	20	E: 533500 N:3308000	1800	1343	0643
39	TRANSIT TO UNPAVED RUNWAY. HAND-OFF UAV CONTROL FROM LRS TO SPC. DEMONSTRATE UAV MANEUVERABILITY. RECOVER ON UNPAVED RUNWAY	28, 57 38	0	N/A	1600	0600	
						TOTAL FLIGHT TIME: 7 HRS 00 MIN	

Figure 1 (b). Example Mission Plan (Cont)

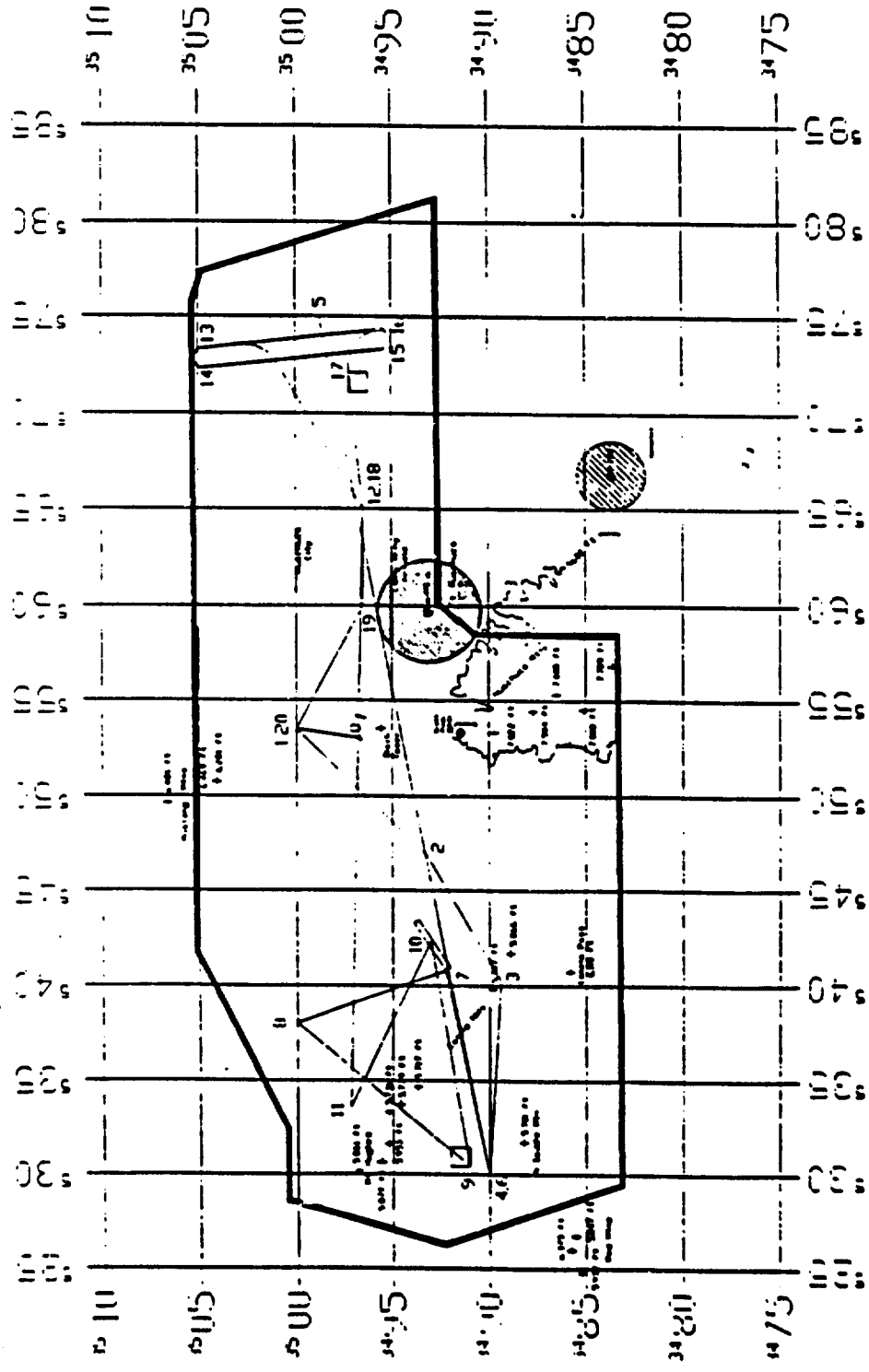

Figure 2. Example Flight Profile

d. Data Collection Forms. The test engineer with assistance from support divisions within his/her organization shall develop data collection forms. The independent evaluator shall review the forms, recommend changes, and approve the final forms. Once approved, the test engineer must ensure that the data collectors are trained to fill out the forms correctly. Appendix B provides sample data forms.

e. Pre-Test Inventory/Test Item Description. The test engineer must document, in a Test Incident Report (TIR) AMC Form 2134 or other format, all test items as they arrive. See AMC Regulation 70-13, Incidents Disclosed During Materiel Testing, for further information. For the air vehicle, this documentation should include the configuration of the air vehicle, the serial number, dimensions, engine type and displacement, propeller size, and control surface design. For the GCS, the test engineer should document the serial number and a general list of its capabilities (e.g., autonomous flight, autopilot). For the GDT, the test engineer should document the serial number, power requirements, operational frequency range, and if applicable, auto-tracking capabilities. In addition, the test engineer should describe the launch system, recovery system, and support equipment functions.

f. System Support Documents. All draft technical manuals and System Support Package (SSP) documentation must arrive in time for review by the test engineer and other support personnel. Manpower and Personnel Integration (MANPRINT) and Reliability, Availability, and Maintainability (RAM) issues require this documentation for analysis.

g. Range Safety Documentation. The range safety officer must certify the UAV system as safe to operate on the range. The range safety officer will brief the UAV operators on range regulations identifying the areas of operation, altitude restrictions, and off-limit areas. In addition, the range safety officer will inspect tracking devices, Flight Termination Systems (FTSs), and IFF transponders, where applicable. For FTSs, the UAV system developer must perform a ground demonstration before government witnesses. The FTS must initiate when commanded to initiate and must not initiate when commanded with the safety pin in place. For FTSs using pyrotechnics, the UAV system developer may connect a test light or siren in place of the actual pyrotechnic during the demonstration. Each test range has its own set of regulations and may require a redundant FTS. Consult your local safety regulations for details.

h. Safety Release/Safety SOP. Requirements for a safety release will vary depending on the type of test, the test range, and the requirements generated by TECOM Headquarters. TECOM HQ will task a TECOM test center safety office to prepare a safety release recommendation IAW AR 385-16. Documents required to support a recommendation may include a Safety Assessment Report (SAR), Health Hazard Assessment Report, Technical Manuals, Maintenance Allocation Chart, Explosive Hazard Classification Data, results of electromagnetic radiation hazard (EMRH) tests, and a nonionizing radiation study by the U.S. Army Environmental Hygiene Agency. If civilian or military

TOP 6-2-740
15 June 1993

nontest personnel (e.g., borrowed soldiers) are used as test participants, the TECOM Human Use Committee (HUC) must review the detailed test plan IAW TECOM Regulation 70-25 to determine the level of risk to which test participants will be exposed. Although the test engineer is ultimately responsible for safety during the conduct of the UAV test, he/she should rely heavily on the installation safety office for guidance during testing. The test engineer and local safety officer must develop a standing operating procedure (SOP) to ensure safety in the areas of: explosive storage and handling; hazardous materials storage and waste disposal; driving on the test range; safety zone for nonessential personnel; rules for mission essential personnel; and other areas of concern. In addition, the test engineer must be aware that military personnel require a TECOM Safety Release to operate or maintain any equipment. Military personnel rarely operate any UAV system equipment during technical and developmental testing due to the high cost of training soldiers and the high dollar value of the UAV under test. These costs are justifiable in the operational phase of testing, but not so during development. However, should the need arise for soldier operation of equipment, the test engineer must plan accordingly and provide new equipment training (NET) to test personnel prior to test conduct.

i. Environmental Documentation. Launch/recovery areas, target areas, fuel storage areas, etc. require environmental documentation. In accordance with AR 200-2, Environmental Effects of Army Actions, every Army action, including testing, must be reviewed for environmental impact. A Record of Environmental Consideration (REC) will be prepared if the UAV test is determined to be within the mission of a test center and discussed within an existing Environmental Impact Statement (EIS) or Environmental Assessment (EA). If this is not the case, the test may require an EA or EIS. An EA can take three to eighteen months to prepare, while an EIS can take years to prepare. Obviously, the test engineer must consult the local Environmental Quality Coordinator (EQC) early in the test planning stage. In addition, the test engineer and EQC should develop an SOP to ensure the environment is not adversely affected during the test. Every test range will have cultural and biological resources that must be avoided. A plan must be developed to ensure hazardous materials and petroleum products are stored and disposed of properly. The test engineer must ensure the UAV system developer understands their responsibility for removal of hazardous materials upon completion of testing. Otherwise, the test organization could incur substantial disposal costs.

j. Frequency Documentation. Frequency coordination helps prevent interference between the UAV uplink and downlink signals and local commercial or military emissions. The area frequency coordinator must approve all operating and communication frequencies. The test engineer insures that all range communications are authorized. The UAV system developer must submit in writing all the planned operating frequencies for the UAV and any additional communication frequencies on a DD Form 1494 to the test engineer. The test engineer will forward the information to the local frequency coordinator. The local frequency coordinator reviews the information and applies for

authorization from the area frequency coordinator. Upon approval, the area frequency coordinator will provide a Radio Frequency Authorization (RFA). The frequency coordinator may authorize use of commercial frequencies for UAV operation on a non-interference basis. However, this is strongly discouraged. Unlike military frequencies, the Department of Defense (DoD) has no control over commercial frequencies and the UAV system developer will then operate the UAV at their own risk. If the UAV system developer chooses to operate on commercial frequencies, the test officer must inform the UAV system developer of the risks of these actions in writing.

k. Emergency Recovery/Crash Investigation Plan. The test engineer shall incorporate a plan for emergency recovery operations. The test engineer shall form a crash investigation team which will include representatives from the UAV system developer, the test range, and the project manager. If the UAV lands on private property, the recovery operations team must include a Judge Advocate General (JAG) officer for legal representation. The test engineer shall identify the team leader, a mobilization point, the mode of transportation to the recovery site, and the recovery rules. The test engineer shall ensure the team carries fire extinguishers, shovels, a map, water jugs, and other necessary items to the recovery site. Once on-site, the recovery team leader must first determine if the UAV is safe to approach. If the team leader feels conditions are safe, the UAV system developer shall replace all safety pins for pyrotechnics and shut off all power. Once the UAV system developer ascertains that all pyrotechnics are unarmed, document the condition of the UAV and recovery site and, if required, take photographs. Finally, the team leader shall release the UAV to the system developer for transport to the maintenance facility.

3.3 Instrumentation.

a. The test engineer shall provide dimensions, power requirements, and weight of tracking devices to assist the UAV system developer with installation. If laser retroreflectors are used, the test engineer shall ensure they are placed in the proper place for optimum tracking. If a C-Band Beacon or other beacon is installed, the test engineer should test the beacon either with a test set or by operating the tracker in concert with the beacon. The test engineer shall also ensure the beacon is powered by the battery bus and not by the alternator/generator. This ensures the beacon is powered at all times so, even if the engine cuts out in flight, the UAV can be tracked to its landing point.

b. The test engineer shall ensure all load cell or scale calibrations are up to date and within tolerance for the test item. (A load cell is an electrical device which measures the pounds force or weight applied). The test engineer shall place the load cells or scales on a smooth level surface. The test engineer shall also mark the locations of the cells or scales to eliminate the need for re-measuring the distances between them each time the test item is weighed. The test engineer should also weigh a known quantity to ensure he/she knows how to use the weight measuring device correctly.

c. The test engineer shall coordinate the placement and connection of test instrumentation to ensure the instrumentation does not inhibit the operation of the UAV system. Locate video cameras, still photography cameras, and their operators in an unobtrusive area outside the established safety zone. Record sample tapes of interior GCS actions, UAV payload video, and any other sources and play them back to ensure connections are correct and the quality is up to standards.

3.4 Data Required. Prepare record forms for systematic entry of data, chronology of tests, and analysis for the final evaluation of the test item. The test engineer shall develop forms to collect information on the arrangement and interconnection of the UAV system components as well as the location of targets. Develop event logs, aural/visual forms, and other required data forms and train the collectors on the proper completion procedures. The test engineer with assistance from the independent evaluator must decide on a format for the Time, Space, Position, Information (TSPI) produced by the tracking device (radar or laser). This includes the units (e.g., m/sec, ft/sec², UTM coordinates) and the media (e.g., 9 track tape, 3 1/2" disk) on which the information is recorded.

4. TEST PROCEDURES.

4.1 Air Vehicle Weight and Center of Gravity Tests.

a. Method. The method described below is for determination of air vehicle weight and two-dimensional center of gravity (CG). For three dimensional CG measurements, consult AMC pamphlet AMCP 706-204. The test engineer should perform the measurements both pre- and post-flight. Knowing the pre- and post-flight weights, the test engineer calculates the amount of fuel consumed and extrapolates endurance from these numbers. CG measurements give the engineer an idea of how the CG location varies as the amount of fuel changes and as the air vehicle configuration changes. Figure 3 provides an example of a generic UAV for illustration purposes.

(1) Determine location of hard points on the air vehicle for placement on the scales or load cells. Ask the UAV system developer for assistance in choosing the locations. Points A, B, and C in Figure 3a provide examples of hard points.

(2) Determine reference lines on the air vehicle for distance measurements. The reference line for the lateral component of the CG should be the centerline of the air vehicle. The reference line for the longitudinal component should be through the nose of the air vehicle or some other fixed point. Lines L_A and L_B , in Figures 3a and 3b, are examples of lateral and longitudinal reference lines, respectively.

(3) Place the air vehicle on the load cells or scales in a level position.

TOP 6-2-040
15 June 1993

(4) Record the weight measurements for each load cell or scale. Weights W_A , W_B , and W_C in Figure 3a correspond to the load cell weights.

(5) Add the individual weight measurements to determine the Gross Vehicle Weight (GVW).

(6) Measure distances perpendicular to the lateral reference line as appropriate, to establish the location of the load cells. Distances L_1 and L_2 are the perpendicular distances in Figure 3a.

(7) Measure the perpendicular distance from the load cell or scale to the longitudinal reference line, L_3 . Distances L_3 and L_4 are the perpendicular distances in Figure 3a.

(8) Photograph the air vehicle to illustrate the test apparatus
and

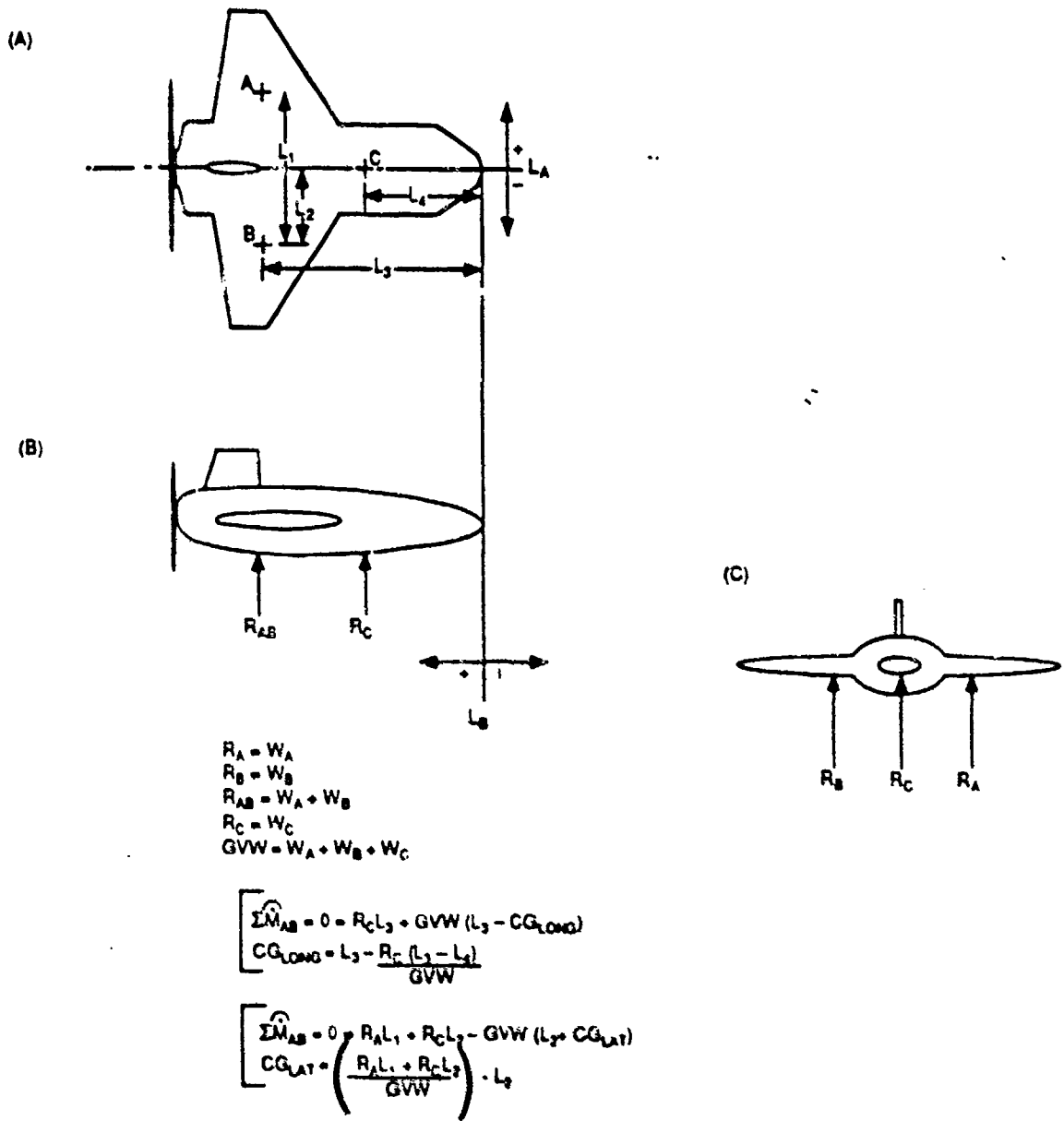

Figure 3. Example of a generic Unmanned Aerial Vehicle (UAV).
(a) Top View, (b) Side View, and (c) Front View.

methodology.

(9) Sum moments using the GVW, distances, and reactions and calculate longitudinal and lateral components of the CG. The formulas in Figure 3 provide examples of these calculations. R_A , R_B , R_{AB} , and R_C represent the reactions at the various points in Figure 3.

b. Data Required. Weight and distance measurements mentioned above are required to calculate the gross vehicle weight and center of gravity.

4.2 Support Vehicles/Trailers Weight and Center of Gravity Tests.

a. Method. The method described is used to determine support vehicle weight and three-dimensional CG. If only a two-dimensional CG determination is required, skip steps 6-11. The test engineer must obtain weight and CG measurements for all support vehicles to certify a UAV system as transportable by C-130 or other means. For vehicles, CG varies as the amount of fuel changes. However, for transportability purposes, this variation is not significant. Consult the independent evaluator for specific test requirements. Fill fuel tanks to the three quarters full mark to establish a baseline and determine gross vehicle weight.

(1) Determine reference lines on the vehicle or trailer. The reference line for the lateral component of the CG should be the center line of the vehicle or trailer. The reference line for the longitudinal component should be through; the front bumper for vehicles, the trailer tongue for trailers, or some other fixed point. The reference line for the horizontal component should be through; the front and rear axle for vehicles or the rear axle parallel to the ground for trailers. Lines L_A and L_B in Figure 4a are examples of longitudinal and lateral reference lines respectively. Line L_C in Figure 4d is an example of a horizontal reference line.

(2) Place the vehicle or trailer on the scale on a smooth level surface. Ensure the tires are inflated to the proper pressure and no personnel are on-board. For vehicles, ensure the fuel tank is three quarters full. For trailers, ensure the tongue is raised until the bed of the trailer is level.

(3) Record the measured weight of each scale. Weights W_A , W_B , and W_C , and W_D in Figure 4a represent the weight on each scale. Add the individual weights to determine the Gross Vehicle Weight (GVW).

(4) Measure the distance from the center of the tire tread on one tire to the center of the tire tread on the opposite tire. Length L_1 represents this distance in Figure 4a. If the front and rear set of tires are of different widths, repeat this process for each axle pair. For dual wheels, measure from the mid-point between the dual wheels instead of the center of the tire tread. Divide the distance by two to determine the center line of the vehicle. In the example, L_2 in Figure 4a represents this dimension.

TOP 6-2-040
 15 June 1993

(5) Measure the distance from the center of the hub of one wheel to the center of the hub of the next wheel for one side of the vehicle. Next, measure the distance from the reference line to the center of the hub of one

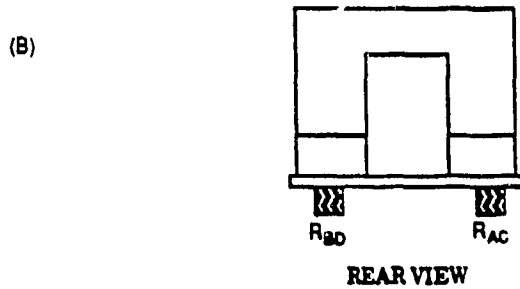
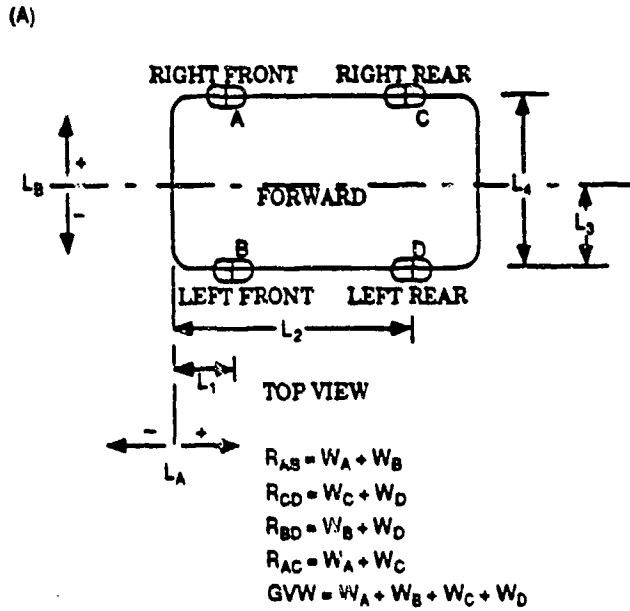

$$\sum \hat{M}_{BD} = 0 = R_{AC}L_4 - GVW(CG_{LAT} + L_3)$$

$$CG_{LAT} = \left(\frac{R_{AC}L_4}{GVW} \right) - L_3$$

Figure 4. Example of a support vehicle, (a) Top View, (b) Rear View.

(C)

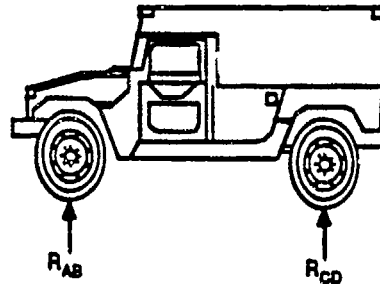

SIDE VIEW

$$\Sigma \hat{M}_{AB} = 0 = R_{CD}(L_2 - L_1) - GVW(CG_{LONG} - L_1)$$

$$CG_{LONG} = \left(\frac{R_{CD}(L_2 - L_1)}{GVW} \right) + L_1$$

(D)

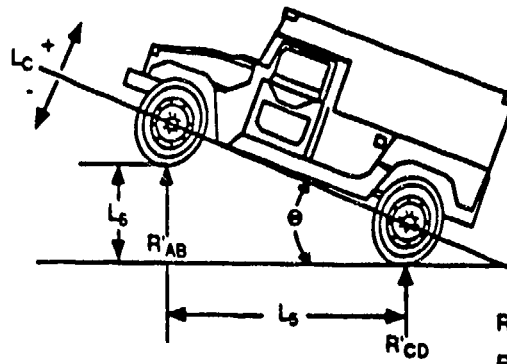

$$\text{TAN } \theta = \frac{L_c}{L_s}$$

$$R'_{AB} = W_A + W_B$$

$$R'_{CD} = W_C + W_D$$

SIDE VIEW INCLINED

$$\Sigma \hat{M}_{CD} = 0 = GVW_{\text{COS } \theta} (L_2 - CG_{LONG}) - GVW_{\text{SIN } \theta} (CG_{LONG}) - R'_{AB} \text{COS } \theta (L_2 - L_1)$$

$$CG_{HOR} = \frac{GVW_{\text{COS } \theta} (L_2 - CG_{LONG}) - R'_{AB} \text{COS } \theta (L_2 - L_1)}{GVW_{\text{SIN } \theta}}$$

Figure 4. Example of a Support Vehicle (Cont),
(c) Side View and (d) Inclined Side View.

wheel. Using this information determine the distance from the reference line to each hub center. Lengths L_1 and L_2 in Figure 4a provide instances of these measurements.

(6) For vehicles, raise the front end with a crane or wrecker and place the front tires on a scale on top of a platform. Inclinations of at least 30 degrees provide the most accurate measure of a three-dimensional center of gravity. However, most vehicles are extremely unstable at this attitude. For this reason, do not attempt to place a vehicle on a platform of more than 76cm (30 in). For trailers, lower the tongue to the scale so that the bed of the trailer is no longer horizontal.

(7) Record the new measured weight for each scale. Weights W'_A , W'_B , and W'_C , and W'_D in Figure 4d represent the new measured weight on each scale. Add the individual weights to determine the Gross Vehicle Weight (GVW). Compare the weight to the value obtained in step (3). The weights should be equal.

(8) Measure the perpendicular distance from the center hub of the rearmost wheel to the center hub of the frontmost wheel. To obtain the perpendicular distance, you must project the position of the hub center of the frontmost wheel to the ground. A plumb bob is helpful in this situation. Length L_5 in Figure 4d is an example of this measurement.

(9) Measure the height of the platform. Length L_6 in Figure 4d is an example of this measurement.

(10) For vehicles, measure the angle of inclination of the frame or body of the vehicle with respect to the horizontal. For trailers, measure the angle of inclination of the frame or bed with respect to the horizontal. Theta is an example of this angular measurement.

(11) Divide the measurement in step (9), L_6 , by the measurement in step (8), L_5 . Take the arctangent of this value and compare it to the angle measured in step (10). The values should be within one degree of each other. If they are not, remeasure L_5 , L_6 , and theta until the measurements provide values within the ± 1 degree tolerance.

(12) Photograph a sample of each vehicle type to illustrate the test apparatus and methodology. Photographs of every vehicle are not necessary.

(13) Sum moments using the GVW, distances, and reactions and calculate longitudinal, lateral, and horizontal components of the center of gravity. The formulas in Figure 4 provide examples of these calculations. R_{AB} , R_{CD} , R_{BD} , R_{AC} , R'_{AB} , and R'_{CD} represent the reactions at the various points in Figure 4.

b. Data Required. Weight, distance, and angle of inclination measurements are required to complete the calculations mentioned above.

4.3 Air Vehicle Dimension Measurements.

a. Method. The UAV system developer usually provides dimensioned drawings of the assembled air vehicle. If the dimensions are not provided or the test engineer believes the provided dimensions are inaccurate, the test engineer shall measure the wingspan, length of the fuselage, height of vertical stabilizers, etc.

b. Data Required. The final test report requires an accurate, dimensioned drawing using the International System of Units (SI). Consult the independent evaluator for accuracy requirements. Accuracy of plus or minus one centimeter is usually sufficient.

4.4 Transportability Tests.

a. Method. The test engineer shall measure the dimensions of all support vehicles and trailers in a ready for transport configuration. This includes HMMWVs with GCS shelters, HMMWVs loaded with support equipment, HMMWVs or 5 tons carrying UAVs in transport containers, generators, GDTs, launchers, etc. Measure the vehicle bumper to bumper length, vehicle width, vehicle height, and shelter height with antennas retracted or removed. Similarly for trailers, measure the length from the trailer tongue to the bumper, width, and height. Next, the test engineer shall load the vehicles on the proposed transportation vehicle. Mock-ups of C-130 and C-5 aircraft are often available and are acceptable substitutes.

b. Data Required. The measurements and actions described above are required for transportation certification. Center of gravity and weight measurements described in section 4.2 are also required.

4.5 Emplacement/Displacement Tests.

a. Method.

(1) Displacement. The displacement test is a measurement of the time to convert a complete system from an operational configuration to a road march configuration. This entails dismantling and packing all equipment (to include air vehicles) and storing them in vehicles (e.g., HMMWVs, 5 tons, trailers). Displacement time starts with all flight required systems powered and in their location for proper operation, a UAV on the runway ready to launch, and all operations personnel at their stations. Displacement time ends when all vehicles are ready for a road march. The test engineer shall obtain a list of equipment and the vehicles they are stowed in from the system developer. With this list, the test engineer trains the data collectors and assigns them to a vehicle. In addition, the test engineer provides the data collectors a stop watch and data collection forms. During test, the data

collector monitors the stowing of equipment in their assigned vehicle and records the elapsed time.

(2) **Emplacement.** The emplacement test is a measurement of the time to go from a road march configuration to a ready for launch configuration. This entails setting up all equipment in their proper location, powering up all equipment required for launch, placing a UAV on the runway ready for launch, and placing all operational personnel at their stations. Emplacement time starts with all vehicles lined up in a road march configuration and ends when the UAV is ready for launch. Both displacement and emplacement are performed by only the personnel outlined in the UAV system manuals obtained from the system developer. This ensures that the displacement and emplacement times are accurate and unbiased by the addition or shortage of UAV personnel.

b. **Data Required.** A list of equipment and storage vehicles is required. In addition, the data collectors must record the start and stop times for both the emplacement and displacement events.

4.6 Flight Tests.

a. **Method.**

(1) Conduct a pre-mission brief from 1 to 3 hours prior to the actual mission to allow sufficient time for the UAV system developer to prepare the UAV for flight. Outline specific mission objectives, flight profile, duration of flight, UAV configuration, maintenance since last flight, role of participants, operational area, safety issues, and current and projected weather conditions. Discuss maximum crosswind requirements, density altitude, and other weather conditions which would preclude launch approval. The final decision to launch will ultimately reside with the test officer based on the system specification. The UAV system developer may still refuse to launch even if the weather conditions and runway size are within the system specification, but will be scored accordingly.

(2) If requested by the test sponsor, tune a spectrum analyzer to the UAV uplink frequency and record the display annotated with IRIG-B time or equivalent. If an incident occurs, the spectrum analyzer will provide a history of the frequency activity in the UAV control band and may rule out outside interference as a cause. The frequency authorization mentioned in para 3.2j will prevent other authorized users from operating in the UAV frequency band, but cannot guarantee that unauthorized users will not use it. Cases of unauthorized use are rare, but without frequency monitoring the test sponsor may have difficulty determining whether an incident was caused by interference or a fault in the UAV system.

(3) Construct a block diagram of the ground support equipment (e.g., GDT, GCS, Launcher, etc.) and UAV. Include the model and serial number of each and all interconnections. Appendix B, page B-8, provides a sample

block diagram.

(4) Draw a diagram of the UAV location with respect to the runway. If a launcher is used, measure the compass direction of the launcher and if requested the angle of inclination of the UAV. See Appendix E, pages B-2 and B-3, for an example.

(5) Photograph and/or video tape the launch, local flight patterns, and recovery to support test results and document any incidents. Annotate the video with IRIG-B time or equivalent. If two video cameras are available during launch, fix one stationary camera on the launcher and pan or follow the UAV off the launcher with the other. If an incident occurs during launch, the fixed camera may show if the launcher was at fault.

(6) Record the downlinked UAV payload video to document payload quality and stability of the UAV as a payload platform. If necessary, record the interior GCS video of the Air Vehicle Operator (AVO) and Mission Payload Operator (MPO) to answer MANPRINT issues. Annotate the video with IRIG-B time or equivalent.

(7) Record the chronological order of events, pertinent remarks, and observations in an engineering laboratory notebook. This information will aid the test engineer in completing and reviewing data collection forms and TIRs. In addition, the information will refresh the test engineer's memory of the test conditions on a particular day and assist the test officer with post-test analysis. Ensure that the data collectors record the information on data collection forms and event logs. See Appendix B for sample forms and event logs.

(8) Draw a diagram of the recovery location noting both the initial impact point and final rest point. See Appendix B, page B-3, for an example. Document any damage with still or motion photography and hand-written notes.

(9) Conduct a post-mission brief. Discuss the number of events completed, but do not discuss test results. Have the AVO recap the mission from start to finish and detail any anomalies. Open the discussion to all participants to explain any perceived failures. Record any preliminary explanations for failure noting the source and the estimated time for a final determination. Outline the objectives and schedule for the next mission.

(10) Review all data collection forms for accuracy. Interview the data collectors when the data does not appear to be correct. Correct any inaccuracies.

b. Data Required. Time, space, position information (TSPI), weather data, video recordings, photographs, data collection forms, and TIRs are required. For sample data items, see Appendices A and B.

4.7 Aural/Visual/Acoustic Tests.

a. Method. Position observers on surveyed locations in a circular pattern. Space the observers 300m to 500m apart so, they cannot see each other's actions and cue the arrival of the UAV. However, in a technical test environment, some cuing is necessary and desirable. Missions rarely occur exactly on schedule. Observers may be positioned for several hours waiting to fulfill their portion of the mission. The test engineer should announce the start of the aural/visual flight pattern. The test engineer shall ensure that all observers have had vision and hearing tests IAW AR 40-501, Standards of Medical Fitness, and do not wear sunglasses during the mission. The test engineer must also ensure the flight path patterns vary the approach direction, vary in altitude, and overfly the observers' positions. In addition, the test engineer shall ensure the navigation lights on the UAV are turned off for the Aural/Visual portion of the mission. Synchronize all watches to IRIG-B time or equivalent. For each pass of the UAV, the observers shall record the time the UAV is detected aurally and the time it is detected visually. Additionally, the test engineer shall record acoustical measurements on a separate set of UAV passes. The recording instrumentation should be calibrated to reduce the effects of ambient noise levels.

b. Data Required. Time of visual detection, time of aural detection, and acoustical measurements are required. Appendix B, page B-7, provides an example Aural/Visual data collection form.

4.8 MANPRINT/RAM Tests.

a. Method. Manpower and Personnel Integration (MANPRINT) and Reliability, Availability, and Maintainability (RAM) issues are important to all tests. The test engineer shall address MANPRINT issues such as: number of personnel required to assemble the UAV and load on the launcher; number of personnel required to control the UAV from the GCS; quality of video displays; and ease of operator software interactions. The test engineer shall collect operation times of the UAV, generators, GCSs, etc. and types of failures for calculations of mean time between failure. The test engineer shall also collect data on items under repair, repair times, and number of personnel required for repair. Consult the independent evaluator to define the level of detail required (e.g., do you stop at the UAV level or divide the UAV into payload subsystem, avionics subsystem, etc.)

b. Data Required. Checklists, data collection forms, and Test Incident Reports for repair actions are required. Appendix B, page B-5, provides an example of a MANPRINT form.

5. PRESENTATION OF DATA.

a. Reduce raw data to a readable form. Correct flight performance data to standard day conditions to reduce the impact of each day's weather on

system performance (Appendix A, page A-3, provides sample Met data). Correlate system events with IRIG-B time or equivalent. Typical flight parameters of interest are service ceiling, rate of climb, endurance, loiter speed, cruise speed, and dash speed. Plot rate of climb versus Density Altitude, Density Altitude versus time, airspeed versus time, and other pertinent plots to better illustrate performance. Compare the planned flight profile versus the actual to analyze navigational accuracy.

b. Review the recorded payload video and assess the stability of the UAV. Does the UAV appear to be a stable platform for both day television and FLIR payloads? Report the results of the maneuverability tests and compare them to the system specification. Assess the data link capability by documenting the farthest distance between air vehicle and Ground Data Terminal and reporting the number of lost link incidents (i.e., loss of air vehicle control by a break in the link between UAV and GCS). If applicable, describe the time required to reacquire a lost link. Describe auto navigation abilities and pitfalls. Compare the navigational accuracy in programmed mode to the accuracy experienced in manual mode. If activated during the test, discuss the emergency recovery system. Does the emergency recovery system minimize damage to the UAV? Does it activate when commanded? Does it discern which signals are supposed to activate it so, that it does not activate when it's not commanded?

c. Review Test Incident Reports (TIR's) in a TIR working group meeting to classify and score incidents. Report corrective actions or explanations for actions that do not require corrective actions. Compare mean time between failure rates versus the system specification and include the results in the final report. Report the results of the MANPRINT/RAM findings. Compare the mean time between failures (MTBFs) required in the system specification to the MTBFs experienced during test.

d. Using the results of the aural/visual/acoustic test, describe the strong points and shortfalls of the UAV's survivability. Perform a statistical analysis of the data to determine the distances at which the observers can see and hear the UAV. Calculate the observer-to-UAV slant range at first and last visual and aural detection. Then, calculate the average and standard deviation of visual and aural detection slant ranges for the group of observers. Further describe the aural characteristics by comparing the aural data with the acoustic signature data recorded by the sound level instrumentation. The Independent Evaluator shall review any statistical methods, recommend changes, and approve the methods.

e. With the results of the weight and center of gravity tests and the transportability tests, determine the acceptable modes of transport (e.g., C-130, C-5, train, etc.) and number of vehicles required (e.g., five C-130 loads). Present your findings to Natick Research Development and Engineering Center and the Military Traffic Management Command (NTMC) to obtain transportability certification.

TOP 6-2-040
15 June 1993

f. Compare the surveyed locations of targets with the locations reported by the UAV to assess target location accuracy. Determine target detection and recognition distances by comparing the detection and recognition times reported by the Mission Payload Operator (MPO) with the UAV location at that time recorded by the tracking device. Perform a similar analysis for the target boards by comparing the payload imagery with the UAV location. Perform a qualitative analysis of the day television and forward looking infrared (FLIR) payload imagery in both wide and narrow field of view (FOV). Look for signs of degradation caused by tight turns, high altitude, and large separation distances between the air vehicle and Ground Data Terminal (GDT). These analyses are also applicable to the data link assessment. Perform qualitative analysis of the data link by reviewing the payload imagery. Determine the point at which imagery degradation falls below standards to define the maximum operating range.

g. Finally, document findings in a formal report. Present test results in the form of graphs, charts, tables, and photographs to facilitate comprehension. Compare system specifications to actual, observed performance. Delineate performance parameters which were exceeded as well as those which did not meet the specification.

Recommended changes to this publication should be forwarded to Commander, ATTN: AMSTE-CT-T, Aberdeen Proving Ground, MD 21005. Technical information may be obtained from Commander, U.S. Army Electronic Proving Ground, ATTN: STEEP-MT-T, Fort Huachuca, AZ 85613-7110. Additional copies are available from the Defense Technical Information Center, Cameron Station, Alexandria, VA 22304-6145. This document is identified by the accession number (AD No.) printed on the first page.

TOP 6-2-040
15 June 1993

(THIS PAGE IS INTENTIONALLY BLANK)

APPENDIX A
METEOROLOGICAL FORMS

1. Page A-2 contains a sample Meteorological table which shows the projected time for sunrise and sunset. This information is critical when scheduling payload missions for low light (dusk and dawn) conditions.

2. Page A-3 contains a sample Meteorological printout of upper air conditions. Pressure, temperature, and wind speed information at the different operational altitudes are required to translate actual test weather conditions to standard day conditions.

TOP 6-2-040
15 June 1993

SOLAR DATA
Nautical Twilight, Civil Twilight,
and Sunrise/Sunset

For: FORT HUACHUCA, ARIZONA
Latitude 31 deg 34 min N Longitude 110 deg 20 min W
Flying Altitude: 0

MAY
1993

ALL TIMES ARE GREENWICH MEAN TIME MINUS 7 Hrs 0 Mins

DAY	BMNT	BMCT	SUN RISE	SUN SET	EECT	EENT
1	0439	0510	0536	1901	1928	1958
2	0438	0509	0535	1902	1928	1959
3	0436	0508	0534	1903	1929	2000
4	0435	0507	0533	1903	1930	2001
5	0434	0506	0532	1904	1931	2002
6	0433	0505	0531	1905	1931	2002
7	0432	0504	0530	1906	1932	2003
8	0431	0503	0529	1906	1933	2004
9	0430	0503	0529	1907	1934	2005
10	0429	0502	0528	1908	1934	2006
11	0429	0501	0527	1908	1935	2007
12	0428	0500	0526	1909	1936	2008
13	0427	0459	0526	1910	1937	2009
14	0426	0459	0525	1911	1937	2010
15	0425	0458	0524	1911	1938	2010
16	0424	0457	0524	1912	1939	2011
17	0424	0456	0523	1913	1940	2012
18	0423	0456	0522	1913	1940	2013
19	0422	0455	0522	1914	1941	2014
20	0421	0454	0521	1915	1942	2015
21	0421	0454	0521	1915	1942	2016
22	0420	0453	0520	1916	1943	2016
23	0419	0453	0520	1917	1944	2017
24	0419	0452	0519	1917	1945	2018
25	0418	0452	0519	1918	1945	2019
26	0418	0451	0518	1919	1946	2019
27	0417	0451	0518	1919	1947	2020
28	0417	0450	0518	1920	1947	2021
29	0416	0450	0517	1920	1948	2022
30	0416	0450	0517	1921	1948	2022
31	0415	0449	0517	1922	1949	2023

BMNT-Beginning Morning Nautical Twilight

EENT-Ending Evening Nautical
Twilight

BMCT-Beginning Morning Civil Twilight

EECT-Ending Evening Civil Twilight

12:40:00 07-18-91 DigiCORR Radiosonde Only File: IA1001.vax
1479 m above sea Page 1
Site Latitude: 31.357 (degrees) Site Longitude: -110.264 (degrees)
720AV BLACK TOWER

Density Altitude (ft)	MSL (ft) Altitude	Press (mb)	Temp (C)	RH (%)	Dev P Temp (C)	Air Density (g/m3)	Wind Direct (deg)	Wind Speed (kts)	Wind W/S (kts)	Wind Spd E/W (kts)	Wind Spd of Sound (kts)	Index of Refrac (Radio)
6610.6	4852	853.9	21.9	28	2.6	1005.0	245	4.0	-1.7	-3.6	34448.6	1.000256
6775.6	5000	849.5	21.8	30	3.5	999.9	243	4.5	-2.0	-4.0	34442.8	1.000257
7689.6	6000	820.1	19.9	27	0.4	972.1	237	9.9	-5.4	-8.3	34331.7	1.000244
8724.3	7000	791.5	18.9	28	0.0	941.4	229	7.0	-4.6	-5.3	34273.6	1.000237
9662.4	8000	763.9	17.0	34	1.1	914.0	327	3.5	2.9	-1.9	34164.3	1.000233
10508.4	9000	737.0	14.4	36	-0.4	890.0	357	7.3	7.3	-0.3	34010.5	1.000225
11410.2	10000	710.8	12.0	51	2.1	865.1	61	6.7	3.3	2.8	33865.6	1.000226
12286.3	11000	685.3	9.3	72	4.6	841.2	93	8.9	-0.5	8.9	33706.8	1.000228
13210.1	12000	660.6	7.4	74	3.1	816.6	98	10.8	-1.5	10.7	33593.9	1.000219
14080.3	13000	636.6	5.1	71	0.3	794.1	100	12.1	-2.1	11.9	33452.7	1.000207
14996.9	14000	613.2	3.3	54	-5.1	770.9	115	12.2	-5.1	11.0	33343.8	1.000192
15973.1	15000	590.6	1.9	47	-8.3	746.5	138	15.4	-11.4	10.3	33258.5	1.000183
16885.7	16000	568.6	-0.2	48	-9.9	724.4	138	14.2	-10.6	9.5	33133.4	1.000176
17803.5	17000	547.4	-2.1	39	-14.1	702.5	134	14.8	-10.3	10.6	33019.4	1.000167
18742.2	18000	526.8	-3.9	35	-17.0	680.8	127	13.4	-8.1	10.7	32908.4	1.00016
19749.1	19000	506.9	-5.0	23	-22.9	658.0	130	13.4	-8.6	10.3	32840.9	1.000152
20804.8	20000	487.6	-5.7	14	-28.9	634.9	129	15.8	-10.0	12.3	32795.6	1.000144
21750.6	21000	469.0	-7.4	13	-31.4	614.6	124	14.9	-8.3	12.4	32692.0	1.000139
22774.5	22000	450.9	-8.4	6	-39.5	593.4	115	10.7	-4.6	9.7	32628.9	1.000133
23632.9	23000	433.5	-10.9	9	-37.9	575.8	130	7.8	-4.9	6.0	32475.1	1.00013
24527.1	24000	416.6	-13.1	12	-36.4	558.0	155	9.0	-8.1	3.9	32341.7	1.000126
25411.1	25000	400.2	-15.4	12	-38.2	540.8	186	4.4	-4.3	-0.4	32200.1	1.000122
26335.9	26000	384.4	-17.3	17	-36.4	523.4	210	2.3	-2.0	-1.2	32078.0	1.000118
27183.1	27000	369.1	-19.9	21	-36.6	507.5	245	1.8	-0.7	-1.6	31917.4	1.000115
28112.1	28000	354.2	-21.8	14	-40.9	490.8	214	1.9	-1.6	-1.0	31795.1	1.00011
29029.5	29000	339.8	-23.8	10	-46.6	474.6	278	1.6	0.2	-1.6	31671.3	1.000106
29903.7	30000	325.9	-26.2	12	-47.3	459.7	288	4.3	1.3	-4.1	31515.3	1.000103
30782.0	31000	312.4	-28.6	9	-52.3	445.0	271	1.4	0.0	-1.4	31361.4	1.000099
31655.1	32000	299.3	-31.1	8	-53.9	430.8	346	6.5	6.3	-1.6	31202.6	1.000096
32525.1	33000	286.7	-33.6	23	-47.4	416.9	6	9.5	9.4	1.0	31041.4	1.000093
33407.7	34000	274.6	-35.9	14	-53.4	403.1	6	14.1	14.0	1.5	30890.1	1.000089
34256.8	35000	262.7	-38.7	9	-59.5	390.4	1	17.4	17.4	0.4	30707.2	1.000087
35088.2	36000	251.3	-41.6	33	-51.5	378.1	2	17.3	17.3	0.5	30514.9	1.000085
34006.7	37000	240.2	-43.8	23	-56.5	364.9	17	12.5	12.0	3.6	30349.4	1.000081
36849.7	38000	229.4	-46.4	22	-59.0	352.7	40	10.1	7.7	6.6	30200.9	1.000079

TOP 6-2-040
15 June 1993

(THIS PAGE IS INTENTIONALLY BLANK)

APPENDIX B
DATA COLLECTION FORMS

1. All forms presented in this appendix are for illustration purposes only. The test engineer must create his/her own forms to meet the needs of their test. In addition, all data presented within the forms is fictional.

2. Pages B-2 and B-3 contain a sample launch/recovery form. It provides a description of the launch area, launch method, recovery method, length of skid, etc. It also provides a section for reporting any anomalies. The test engineer will find this one of the most valuable tools for post-test TIR production.

3. Page B-4 contains a sample event log used in the mission control room. The events track with the events of a flight profile. The log provides a chronological history of the overall test with a brief description of any anomalies. Event logs may also be used for recording events which took place in the Ground Control Station (GCS) or Mission Planning Station (MPS).

4. Pages B-5 and B-6 contain sample MANPRINT and Emplacement/Displacement forms. Although different tests require a different level of detail, these forms should help the test engineer create his/her own form to meet the test needs.

5. Page B-7 contains a sample Aural/Visual form for human detection of a UAV. Data collectors must have a hearing test before selection. Flight profiles must vary the direction that the UAV flies over the data collectors to prevent cuing.

6. Page B-8 contains a sample block diagram of the test site set-up. UAV contractors typically have spare GDTs and GCSs. The site set-up form allows the test engineer to keep track of the equipment used as well as the configuration. Notice that the GDT locations are surveyed locations. If the test range is capable, the tracking system can translate and rotate the coordinates displayed in the mission control room to the coordinates of the GDT location. Then, if the GDT loses track of the UAV, mission control personnel can give the operator an azimuth and elevation to point the GDT for reacquisition.

TOP 6-2-040
15 June 1993

ITR MASTER EVENT LOG (FORM E-0)

CONTRACTOR ACME UAV ITR TEST # 123 FLIGHT # 25 DATE 5 Sep 92

<u>EVENT</u>	<u>ZULU TIME</u>	<u>NOTES</u>
FAA/IFF TRANSPONDER CHECK	<u>0150</u>	<u>Transmitting C 0304</u>
NAVIGATION LIGHT CHECK	<u>0152</u>	<u>Lights O.K.</u>
C-BAND BEACON CHECK	<u>0155</u>	<u>PPS-16 radar locked</u>
UPDATE LOST LINK WAYPOINT	<u>0158</u>	<u>AVO reports N: 3495230 E: 456312</u>
LAUNCH SENSOR AIR VEHICLE	<u>0204</u>	
TRANSIT TO HOLDING POINT (WP 1)	<u>0207</u>	<u>In-flight checks complete transiting to holding point</u>
HANDOFF CONTROL EXTERNAL TO LCS	<u>0212</u>	<u>Internal pilot has control</u>
HANDOFF CONTROL FROM LCS TO GCS	<u>0214</u>	<u>Transfer from GCS has control</u>
TRANSIT TO WP 2	<u>0215</u>	<u>Transiting to first waypoint</u>
INHIBIT GPS RECEIVER/GDT UPLINK TO MIN.	<u>0217</u>	<u>GPS receiver off</u>
TRANSIT TO WP 3, CONTINUE UNAIDED NAV	<u>0222</u>	<u>Event canceled. UAV drifting off course. GDT ranging</u>
CONDUCT FREQUENCY CHANGE DURING TRANSIT		<u>problem. AVO is reactivating GPS receiver.</u>
TRANSIT TO AREA "E", CONT. UNAIDED NAV	<u>0227</u>	<u>AVO climbing to search altitude. Unaided Nav canceled.</u>
TURN GPS RECEIVER/GDT UPLINK ON		
START 30 MIN AREA SEARCH OF AREA "E"	<u>0235</u>	<u>Beginning Area Search.</u>
END 30 MIN AREA SEARCH OF AREA "E"	<u>0305</u>	<u>MPO located two targets within area. 1 jeep and 1 truck</u>
START 5 MIN TARGET LOCATION IN AREA "E"	<u>0306</u>	<u>MPO obtaining coordinates for one of the targets.</u>
END 5 MIN TARGET LOCATION IN AREA "E"	<u>0309</u>	<u>MPO states truck coordinates are N: 3619500 E: 456400</u>
CONDUCT 5 MIN TARGET LOCATION		
TRANSIT TO AREA "G" (WP 5)	<u>0312</u>	<u>Transiting to next search area.</u>
CONDUCT FREQUENCY CHANGE DURING TRANSIT	<u>0315</u>	<u>Frequency change complete.</u>
START 30 MIN AREA SEARCH OF AREA "G"	<u>0330</u>	<u>AVO states GDT status message shows a weak link.</u>
END 30 MIN AREA SEARCH OF AREA "G"		<u>Event canceled.</u>
START 5 MIN TARGET LOCATION IN AREA "G"	<u>0333</u>	<u>AVO states signal strength is returning. AVO wishes to</u>
END 5 MIN TARGET LOCATION IN AREA "G"		<u>continue mission.</u>
CONDUCT 5 MIN TARGET LOCATION IN AREA	<u>0335</u>	<u>MPO begins 30 min. search. Search completed at 0403</u>
TRANSIT TO AREA "D" (WP 6)	<u>0404</u>	<u>MPO located 1 truck coordinates N: 3620870 E : 454345</u>
DURING TRANSIT UPDATE TO AREA "I"	<u>0408</u>	<u>AVO transits to WP 6. AVO wishes to WP 7 at 0410.</u>

FORM IDENTIFIER 917A - 1

MANPOWER, PERSONNEL, AND TRAINING
DATA SHEET

1. Evaluator Name/Number: John Doe / Ext. 3322
2. Test Scenario (Day, Date, and/or Event Name) & Contractor: Flight Operations, 5 Sep 92, ACME UAV
3. Number of operators and maintainers to support the system operation during the scenario: 8
4. Duration of operation : 3 hrs 43 min
5. Number of operators required for one crew shift:
 - Mission Planning Station: 2
 - Air Vehicle Operators: 2
 - Mission Payload Operators: 1
 - Launch/Recovery Personnel: 3
 - Other Operator Personnel: -
 - Total: 10
6. Number of personnel required to transport the system: N/A
7. Is the number recorded in #6 above equal to, less than, or greater than the number observed who were operating the system? N/A Total difference? N/A
8. Number of personnel required to set-up the system for operation: 3
9. Time required to set-up the system for operation: 10 minutes
10. Is the total number of operators and maintainers used during the scenario equal to, less than, or greater than the number specified as being required in the contractor's proposal? No Total difference? _____
11. Comments (if required): System transported to staging area for previous day's mission. No transport required for this mission.
Set-up time corresponds to time required for pre-flight system checks.

DATA COLLECTION FORM
FOR EMPLACEMENT/DISPLACEMENT

FORM IDENTIFICATION:

DATA COLLECTOR John Doe DATE 5 Sep 92

TEST SITE IDENTIFICATION (PLACE, EVENT NAME):
Unpaved Runway, UAV load

CONTRACTOR: ACME UAV

1. HOW MANY DESIGNATED EMPLACEMENT LOADS? 1

2. RECORD THE TOTAL TIME IT TAKES TO EMLACE THE UAV FROM ROAD MARCH CONFIGURATION INTO RUNNING CONFIGURATION (INCLUDING DELAYS): 43 minutes

3. RECORD THE SUBSYSTEM OBSERVED, THE TIME TO EMLACE, AND THE NUMBER OF PERSONNEL EMLACING THE SYSTEM:
UAV disassembled and placed in container. Container then transferred to 5 ton for transport. Total Time: 43 min. 3 personnel

4. RECORD ANY INTERRUPTIONS, I.E. ALL UNSCHEDULED DELAYS, DURING EMLACEMENT.

INTERRUPTION I.D. TIME SPENT CORRECTING

5 ton truck loading crane required 15 minutes
hydraulic cil. Delay caused by
equipment which is not part of
deliverable UAV system.

5. IF THERE WAS A TASK THAT TOOK UP MOST OF THE TIME TO COMPLETE AN EMLACEMENT OF A SUBSYSTEM, RECORD THE TASK, THE SUBSYSTEM IN WHICH IT WAS DONE, AND HOW LONG IT TOOK TO COMPLETE:

TASK AND SUBSYSTEM	TIME
<u>Container Packing UAV</u>	<u>17 minutes</u>

DATA COLLECTION FORM - AURAL/VISUAL SUBTEST				
Data Requirement # 40 - Aural and Visual AV Signatures				
ITR Test # 123	Ambient Noise Level: Low		Flight Profile #25	
Contractor: ACME	Pass Number: 1	Test Personnel: g		
Date: 1 Sep 92		Observer & Ph#: Jane Doe/ ext. 3322		
Observer Location: Station 3		Recorder & Ph#: John Doe/ ext. 3322		
Test Conditions (Weather, Noise, etc.): Clear and Windy				
Time Detected (MM:MM:SS)	Direction (Circle)	Altitude (Circle)	Background: (Noise Level, Trees, Clouds)	
Aural 02:34:07	W ^N _(S) E	(H) L	Windy Clear Sparse Tree Cover	
Visual 02:36:26	W ^N _(S) E	(H) L	Same as Above	
Time Lost (MM:MM:SS)	Direction (Circle)	Altitude (Circle)	Background: (Noise Level, Trees, Clouds)	
Aural 02:37:02	W ^N _S E	(H) L	Same as Above	
Visual 02:38:57	W ^N _S E	(H) L	Same as Above	
Ability to Track:	Good	Fair	Poor	
Aural		X		
Visual			X	
Comments				
No Distractions by Other Aircraft during Test.				
Recipient: Terri Comfort		Signature: <i>[Signature]</i>		
Authenticated By: David S. Minshew		Signature: <i>[Signature]</i>		

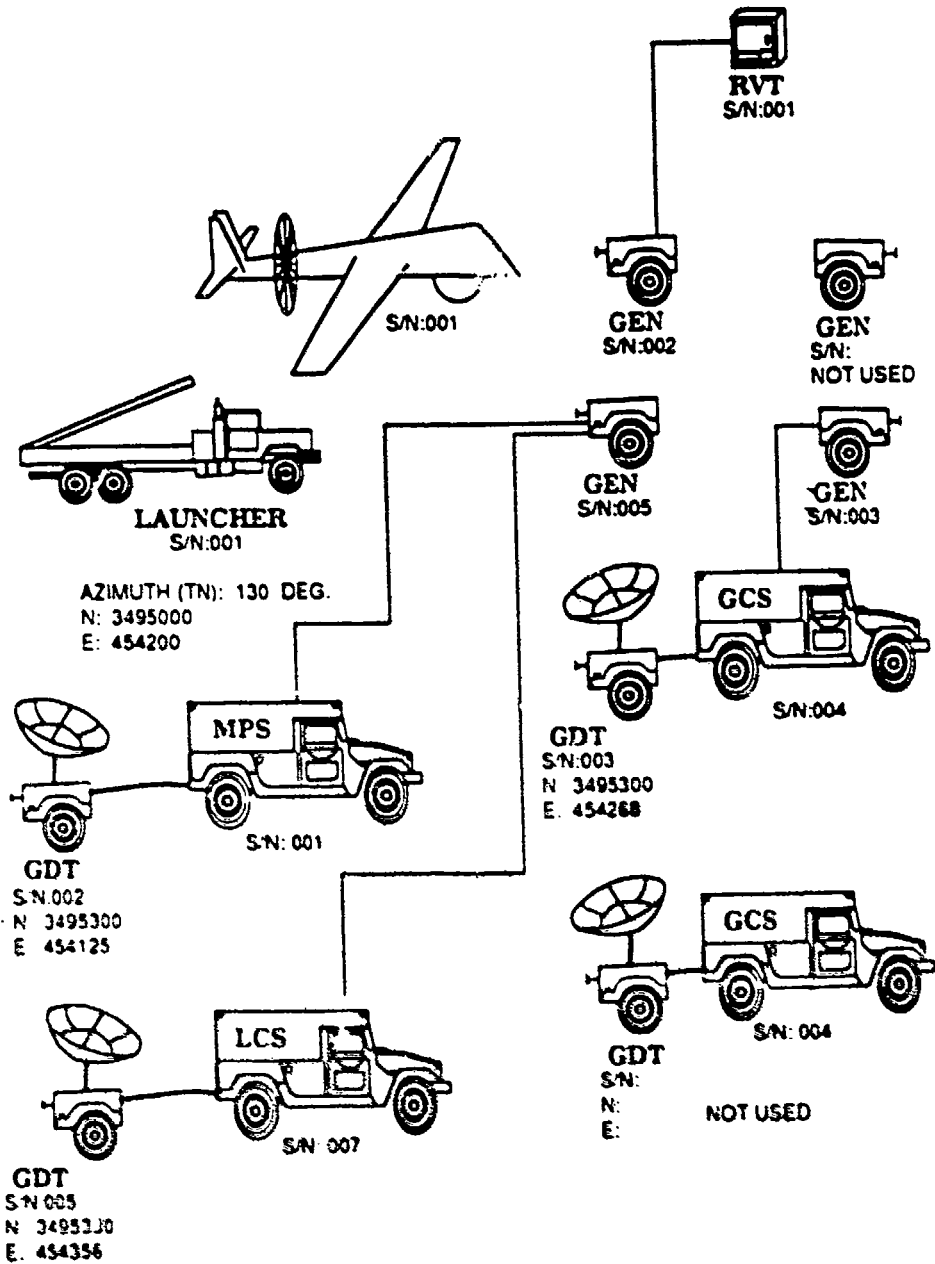

APPENDIX C
ACRONYMS LIST

AMC	Army Materiel Command
AVO	Air Vehicle Operator
CG	Center of Gravity
DoD	Department of Defense
EMC	Electromagnetic Compatibility
EMI	Electromagnetic Interference
FAA	Federal Aviation Administration
FLIR	Forward Looking Infrared
FOV	Field Of View
FTS	Flight Termination System
GCS	Ground Control Station
GDT	Ground Data Terminal
GPS	Global Positioning System
GVW	Gross Vehicle Weight
HMMWV	High Mobility Multipurpose Wheeled Vehicle
HQ	Headquarters
IAW	In Accordance With
IEP/TDP	Independent Evaluation Plan / Test Design Plan
IFF	Identify Friend or Foe
IRIG-B	Inter-Range Instrumentation Group - Format B
JAG	Judge Advocate General
LCS	Launch Control Station
MANPRINT	Manpower and Personnel Integration

TOP 6-2-040
15 June 1993

MOA	Military Operating Area
MPO	Mission Payload Operator
MPS	Mission Planning Station
MSDS	Material Safety Data Sheet
MTP	Material Test Procedure
RAM	Reliability, Availability, and Maintainability
RATO	Rocket Assisted Take-Off
RFA	Radio Frequency Authorization
RVT	Remote Video Terminal
SAR	Safety Assessment Report
SSP	System Support Package
TECOM	Test and Evaluation Command
TEMP	Test and Evaluation Master Plan
TIR	Test Incident Report
TOP	Test Operations Procedure
TSPI	Time, Space, Position Information
UAV	Unmanned Aerial Vehicle
UTM	Universal Transverse Mercator
WGS	World Geodetic Survey
WP	Waypoint

APPENDIX D REFERENCES

1. AMC Regulation 70-13, Incidents Disclosed During Materiel Testing, 27 July 1988.
2. AR 200-2, Environmental Effects of Army Actions, 1 September 1981, with Change 1, 15 September 1982.
3. AR 40-501, Standards of Medical Fitness, January 1989.
4. AR 385-16, System Safety Engineering and Management, 3 May 1990.

REFERENCES FOR INFORMATION ONLY

- a. AMC Pamphlet 706-204, Helicopter Performance Testing, 1 August 1974.
- b. FAA 7610.4 G, Special Military Operations, 1 July 1986.
- c. MTP 7-2-040, Drone Aircraft, 25 March 1970.
- d. U.S. Army Electronic Proving Ground, Test Officer's Handbook, November 1990.