

AL-TR-1992-0106

AD-A267 754



Handwritten circled number '2' and initials 'HJ'

**BIOEFFECTS OF RADIOFREQUENCY RADIATION ON
CELL GROWTH AND DIFFERENTIATION.
VOLUME 1: ENGINEERING CONSIDERATIONS**

ARMSTRONG

DTIC
ELECTE
AUG 10 1993
A D

David L. Banks
Wesley W. Shelton
James C. Toler

Bioengineering Center
Office of Interdisciplinary Programs
Georgia Institute of Technology
Atlanta, GA 30332

**OCCUPATIONAL AND ENVIRONMENTAL HEALTH DIRECTORATE
RADIOFREQUENCY RADIATION DIVISION
2503 D Drive
Brooks Air Force Base, TX 78235-5102**

June 1993

Final Technical Report for Period January 1988 - October 1991

Approved for public release; distribution is unlimited.

93-18359

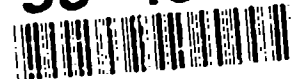

Handwritten number '4218'

LABORATORY

638

**AIR FORCE MATERIEL COMMAND
BROOKS AIR FORCE BASE, TEXAS**

NOTICES

When Government drawings, specifications, or other data are used for any purpose other than in connection with a definitely Government-related procurement, the United States Government incurs no responsibility or any obligation whatsoever. The fact that the Government may have formulated or in any way supplied the said drawings, specifications, or other data, is not to be regarded by implication, or otherwise in any manner construed, as licensing the holder, or any other person or corporation; or as conveying any rights or permission to manufacture, use, or sell any patented invention that may in any way be related thereto.

The animals involved in this study were procured, maintained, and used in accordance with the Animal Welfare Act and the "Guide for the Care and Use of Laboratory Animals" prepared by the Institute of Laboratory Animal Resources-National Research Council.

The Office of Public Affairs has reviewed this report, and it is releasable to the National Technical Information Service, where it will be available to the general public, including foreign nationals.

This report has been reviewed and is approved for publication.

JAMES H. MERRITT, B.S.
Project Scientist

DAVID N. ERWIN, Ph.D.
Chief, Radiofrequency Radiation Division

REPORT DOCUMENTATION PAGE

Form Approved
OMB No. 0704-0188

Public reporting burden for this collection of information is estimated to average 1 hour per response, including the time for reviewing instructions, searching existing data sources, gathering and maintaining the data needed, and completing and reviewing the collection of information. Send comments regarding this burden estimate or any other aspect of this collection of information, including suggestions for reducing this burden, to Washington Headquarters Services, Directorate for Information Operations and Reports, 1215 Jefferson Davis Highway, Suite 1204, Arlington, VA 22202-4302, and to the Office of Management and Budget, Paperwork Reduction Project (0704-0188), Washington, DC 20503.

1. AGENCY USE ONLY (Leave blank)		2. REPORT DATE June 1993	3. REPORT TYPE AND DATES COVERED Final, January 1988 - October 1991	
4. TITLE AND SUBTITLE Bioeffects of Radiofrequency Radiation on Cell Growth and Differentiation. Volume 1: Engineering Considerations			5. FUNDING NUMBERS C - F33615-83-K-0600 PE - 62202F PR - 7757 TA - 01 WU - 78	
6. AUTHOR(S) David L. Banks, Wesley W. Shelton, and James C. Toler				
7. PERFORMING ORGANIZATION NAME(S) AND ADDRESS(ES) Bioengineering Center Office of Interdisciplinary Programs Georgia Institute of Technology Atlanta, GA 30332			8. PERFORMING ORGANIZATION REPORT NUMBER	
9. SPONSORING/MONITORING AGENCY NAME(S) AND ADDRESS(ES) Armstrong Laboratory (AFMC) Occupational and Environmental Health Directorate Radiofrequency Radiation Division 2503 D Drive Brooks Air Force Base, TX 78235-5102			10. SPONSORING/MONITORING AGENCY REPORT NUMBER AL-TR-1992-0106	
11. SUPPLEMENTARY NOTES Armstrong Laboratory Technical Monitor: James H. Merritt, (210)536-3175				
12a. DISTRIBUTION/AVAILABILITY STATEMENT Approved for public release; distribution is unlimited,			12b. DISTRIBUTION CODE	
13. ABSTRACT (Maximum 200 words) This report details the engineering considerations of a program designed to investigate the effects of chronic low-level radiofrequency radiation (RFR) exposure on cell growth and differentiation. The protocol required the exposure (1 mW/cm ² 20 hours daily [average], 7 days per week) of 200 female, mammary-tumor-prone mice (strain C3H/HeJ) to 435-MHz pulsed-wave (1.0 μs pulse width, 1.0 kHz pulse rate) RFR for a duration of 21 months. In addition, a sham-exposure group consisting of 200 female, C3H/HeJ mice was housed under identical conditions, but not exposed to the 435-MHz pulsed-wave radiation. The program's engineering considerations involved developing and providing the facility and equipment used to expose the mammary-tumor-prone mice and the development of a procedure for reliable identification of the mice. Also described are the design of the antenna and transmitter system, animal caging, cage washing procedures, and the data collection system.				
14. SUBJECT TERMS Bioeffects of radiofrequency radiation; Mammary tumors and electromagnetic fields; Electromagnetic field studies			15. NUMBER OF PAGES 46	
			16. PRICE CODE	
17. SECURITY CLASSIFICATION OF REPORT UNCLASSIFIED	18. SECURITY CLASSIFICATION OF THIS PAGE UNCLASSIFIED	19. SECURITY CLASSIFICATION OF ABSTRACT UNCLASSIFIED	20. LIMITATION OF ABSTRACT UL	

TABLE OF CONTENTS

Section No.	SECTION TITLE	Page No.
I	INTRODUCTION.....	1
II	CIRCULAR, PARALLEL-PLATE WAVEGUIDE.....	2
III	SLOTTED CYLINDER ANTENNA.....	7
IV	TRANSMITTER SYSTEM.....	12
V	ANALYSIS OF THE ANTENNA, DISTRIBUTION, AND PARALLEL-PLATE SYSTEMS.....	18
VI	CAGE CONSIDERATIONS.....	26
VII	CAGE WASHER SYSTEM.....	29
VIII	DATA ACQUISITION SYSTEM.....	31
IX	ELECTRONIC BALANCE SYSTEM.....	32
X	OVERALL FACILITY DESCRIPTION.....	33
XI	ANIMAL IDENTIFICATION PROCEDURE.....	36
XII	REFERENCES.....	37
TABLE 1	OVERALL PERFORMANCE SPECIFICATIONS FOR MICON MODEL R9DAT TRANSMITTER.....	17

DTIC QUALITY INSPECTED 3

Accession For	
NTIS CRA&I	<input checked="" type="checkbox"/>
DTIC TAB	<input type="checkbox"/>
Unannounced	<input type="checkbox"/>
Justification	
By	
Distribution /	
Availability Codes	
Dist	Avail and/or Special
A-1	

LIST OF FIGURES

Figure No.	FIGURE TITLE	Page No.
1	Details of plate construction showing the 8 petals.....	5
2	Pedestal used to support circular, parallel-plate waveguides.....	6
3	Slotted cylinder antenna.....	8
4	Technique used to assemble slotted-cylinder antenna.....	10
5	Technique used to mount cables to slotted-cylinder antenna.....	11
6	Photograph of MICON Model R9DAT transmitter.....	13
7	Block diagram of MICON Model R9DAT transmitter.....	14
8	Diagram of impedance transforming balun.....	22
9	Measured field patterns for tier 1 and tier 2 of the parallel-plate waveguide exposure system.....	24
10	Measured field patterns for tier 3 and tier 4 of the parallel-plate waveguide exposure system.....	25
11	Final cage design.....	28
12	Cage washer.....	30
13	Electronic balance/data acquisition system.....	32
14	Overall layout of the RFR facility.....	34

BIOEFFECTS OF RADIOFREQUENCY RADIATION ON CELL GROWTH AND DIFFERENTIATION

VOLUME 1: ENGINEERING CONSIDERATIONS

I. INTRODUCTION

This report details the engineering considerations of a program designed to investigate the effects of chronic low-level radiofrequency radiation (RFR) exposure on cell growth and differentiation. Preceding portions of the program included, in chronological order, a protocol study [1], a feasibility analysis [2] and construction of a prototype RFR exposure facility [3]. The protocol required the exposure (1 mW/cm², 20 hours daily (average), 7 days per week) of 200 female, mammary-tumor-prone mice (strain C3H/HeJ) to 435-MHz pulsed-wave (1.0 μ s pulse width, 1.0 kHz pulse rate) RFR for a duration of 21 months. In addition, a sham-exposure group consisting of 200 female, C3H/HeJ mice was housed under identical conditions, but not exposed to the 435-MHz pulsed-wave radiation. Therefore, the program's engineering considerations involved developing and providing the facility and equipment used to expose the mammary-tumor-prone mice plus developing a procedure for reliably identifying the mice. Some features of the facility and equipment used for this program were identical to those used in previous bioeffects investigations, and their descriptions have been published in other reports; therefore, only a brief description of previously reported items, along with descriptions of features unique to this program, are presented in the following sections of this report.

Sections II, III, and IV describe the major engineering considerations associated with identifying the design for the Facility's exposure antenna, the construction of the exposure antenna, and the transmitter used to feed the exposure antenna, respectively. Section V describes analytical efforts conducted to assure the adequacy of the exposure antenna and transmitter, while the cages used to house the animals are described in Section VI. The cage washer used to clean the cages is described in Section VII, and Section VIII describes the system used for data collection. The electronic balance used to weigh the animals is described in Section IX. In Sections X and XI, the overall exposure facility and the animal identification procedure are described, respectively.

II. CIRCULAR, PARALLEL-PLATE WAVEGUIDE

Two research programs preceded the effort to actually construct a facility for long-term, low-level RFR exposure of large rodent populations. In the first of these two programs, several commonly used and new RFR facility concepts were theoretically analyzed to determine their adequacy for long-term bioeffects studies in the 420-to-450 MHz frequency range. **Of these candidate designs for an RFR exposure system, the circular, parallel-plate waveguide fed by a slotted cylinder feed antenna emerged as the optimal exposure system with regard to technical adequacy and cost-effectiveness.** A prototype of this concept was constructed and extensively evaluated during the second research program. Results from these two programs are summarized in this section and the next to provide reference information for the subsequent discussion of the final RFR facility construction and evaluation.

Possible Radiation Facility Concepts

Both new and commonly used RFR facility concepts were analyzed [2] to determine their adequacy for long-term bioeffects studies involving large rodent populations exposed to 420-to-450 MHz fields. These concepts were:

- circular waveguide radiation,
- free-space radiation,
- compact range radiation, and
- circular, parallel-plate radiation.

Primary technical considerations during these concept analyses were exposure field configurations, ease of animal access, dosimetry, and nonperturbing provisions for water and food delivery. Nontechnical matters such as construction/maintenance costs and floor space requirements were also considered. These analyses lead to the selection of the circular, parallel-plate system.

Circular, Parallel-Plate Waveguide Considerations

An examination of the open literature revealed no indication that circular, parallel-plate waveguides had been considered as a radiation concept for bioeffects studies involving large rodent populations. However, these waveguides can be fed at their center in such a way that energy travels radially outward to a circular array of animal cages. With the feed antenna and parallel plates designed for circular symmetry, the exposure field will also exhibit circular symmetry, and all caged animals will be exposed to essentially the same field.

The field configuration in circular, parallel-plate waveguides is a function of the spacing between the plates. For example, when the plate spacing is less than one-half wavelength, only the dominant TEM mode propagates. In this mode, the electric field is normal to the plates and is said to be vertically polarized with respect to the plates. When spacing between the plates is greater than one-

half wavelength, both the TE and TM modes propagate. For the TE mode, the electric field is parallel to the plates and is said to be horizontally polarized with respect to the plates. When plate spacing is maintained greater than one-half wavelength but less than one wavelength, only the lowest-order TE mode propagates.

The initial step in designing the circular, parallel-plate radiation system was to determine the diameter of a single plate that would support n cages arrayed around the plate periphery. For an intercage separation of h , the equation

$$D = \frac{nh}{\pi} \quad (1)$$

was used to calculate a family of plate diameters as functions of cage spacing and number. An intercage separation of 45.7 cm (18 in.) was chosen to maintain intercage scattering of the electric field within tolerable limits [4]. The initial calculation showed that, for 100 cages with an intercage separation of 45.7 cm (18 in.), an impractical plate diameter of 14.6 m (48 ft) would be required. However, the exposure criteria would still be met if several sets of waveguides were stacked atop each other in a tier arrangement. Calculations showed that 4 sets of stacked plates with 3.6 m (12 ft) diameters would be adequate for exposing 100 animals whose intercage separation was 45.7 cm (18 in.).

As noted earlier, spacing between the plates had to be maintained greater than one-half wavelength but less than one wavelength for propagation of the lowest-order TE mode. With a frequency of 435 MHz (midway in the frequency range of 420-to-450 MHz), this criterion translated to

$$13.57 < S < 27.14, \quad (2)$$

where S is the spacing between plates in inches. A plate spacing of 45.7 cm (18 in.) was conveniently chosen. An area with a 6.1 m x 6.1 m (20 ft x 20 ft) floor space and 3 m (10 ft) ceiling height would adequately house a facility containing 4 sets of 3.6-m (12 ft) diameter plates separated by 45.7 cm (18 in.). The floor space would permit appropriate microwave absorbing material 45.7 cm (18 in. thick material offers -30 dB reflectivity at 500 MHz) to line the facility walls, and sufficient space around the plates to access the animals.

The remaining considerations were calculations of power density variation across the height and width of cages used to house the rodents, antenna types suitable for feeding the waveguide structures, transmitter output power requirements, and overall facility cost. Analysis of power density variation showed that the TE mode exposure environment provided a cosine-squared distribution between the plates. These calculations showed that variations in both vertical and horizontal power density across an animal cage were less than 0.5 dB, and were therefore acceptable. Transmitter output power calculations revealed that about 105 W would provide a 1.0 mW/cm² exposure environment between the plates.

Construction of the Circular Parallel-Plate Waveguides

Two identical four-tier assemblies of circular, parallel plates with slotted-cylinder feed antennas were constructed for this program. One was used for actual exposure of the mice while the other was used for sham exposure.

The two four-tier assemblies of circular, parallel plates (1 for exposure, 1 for sham-exposure animals) were constructed using 10 circular aluminum plates with 3.6 m (12 ft) diameters. To meet the protocol requirements, cages were arranged around the plate peripheries with an intercage spacing of 22.8 cm (9 in.) to accommodate 200 mice. Five circular plates made up the four exposure waveguides while the remaining five circular plates made up the four sham-exposure waveguides. The design of these plates allowed for the possibility of moving the entire facility to another location at some future date. Therefore, each plate was constructed of 8 petals, each with a 1.8 m (6 ft) outer radius and a width dictated by a 45° central angle. Lap joints 2.54 cm (1 in.) wide were milled on the two radial edges of each petal to provide mating surfaces necessary for joining 8 adjacent petals into 1 complete plate. Type 6061-T6 aluminum sheet metal with a 0.4687-cm (0.1875 in.) thickness was selected for the petals since it was relatively lightweight, easily machined, and sufficiently thick to provide the necessary structural strength and mating surfaces for lap joints. A total of 85 (5 spares) of these petals were cut from 3.6 m x 1.8 m (12 ft x 6 ft) Type 6061-T6 aluminum. The fabrication involved sizing each petal to a 45° central angle, and then cutting a 1.8 m (6 ft) diameter outer radius and a 5 cm (2 in.) diameter inner radius on each petal. The inner radius provided a 10 cm (4 in.) hole in the center when 8 petals were joined together to form a plate. This hole was used for installation of the slotted-cylinder antenna. After petals were cut to the proper size, lap joints were milled along the radial edges of each petal. A drawing of the 8 petals assembled into a plate is shown in Figure 1.

Pop rivets spaced 15.2 cm (6 in.) apart along the lap joints held the assembly together. Plastic rods with 3.8 cm (1.5 in.) diameters maintained the 45.6 cm (18 in.) separation distance. Threaded nylon screws joined the plastic rods together through the metal plates. The individual petals were primed and then given two coats of off-white paint. A 61-cm (24 in.) high pedestal served as the base for each assembly. The pedestal consisted of a center post with eight radial panels. These panels were positioned under the lap joints in the bottom plate. Attachment to the plastic spacer rods was provided by threaded nylon bolts. The bottom plate and the pedestal were electrically isolated from one another. Large-head bolts in the bottom of each pedestal panel provided a leveling capability for the assembled waveguides. Steel cables with turn-buckle adjusters were attached between pedestal panels at lower, outside corner positions to add rigidity to the assemblies. A drawing of the support pedestal is shown in Figure 2.

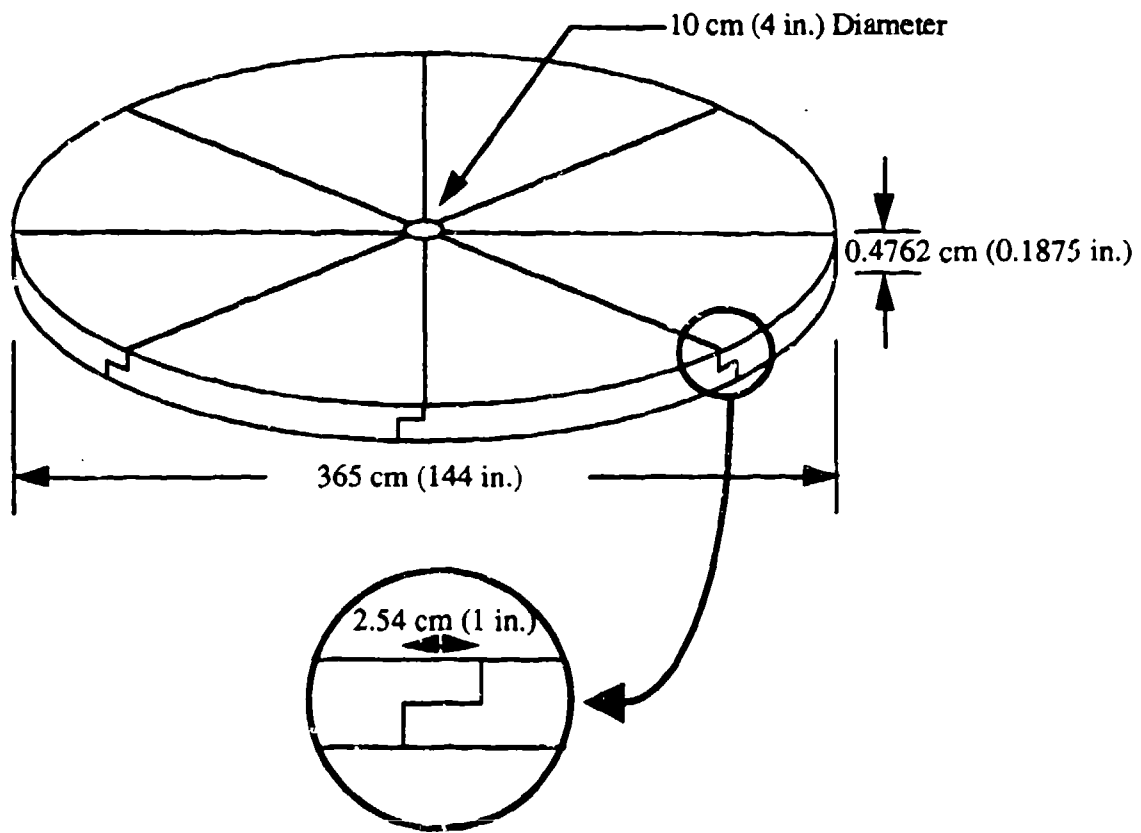
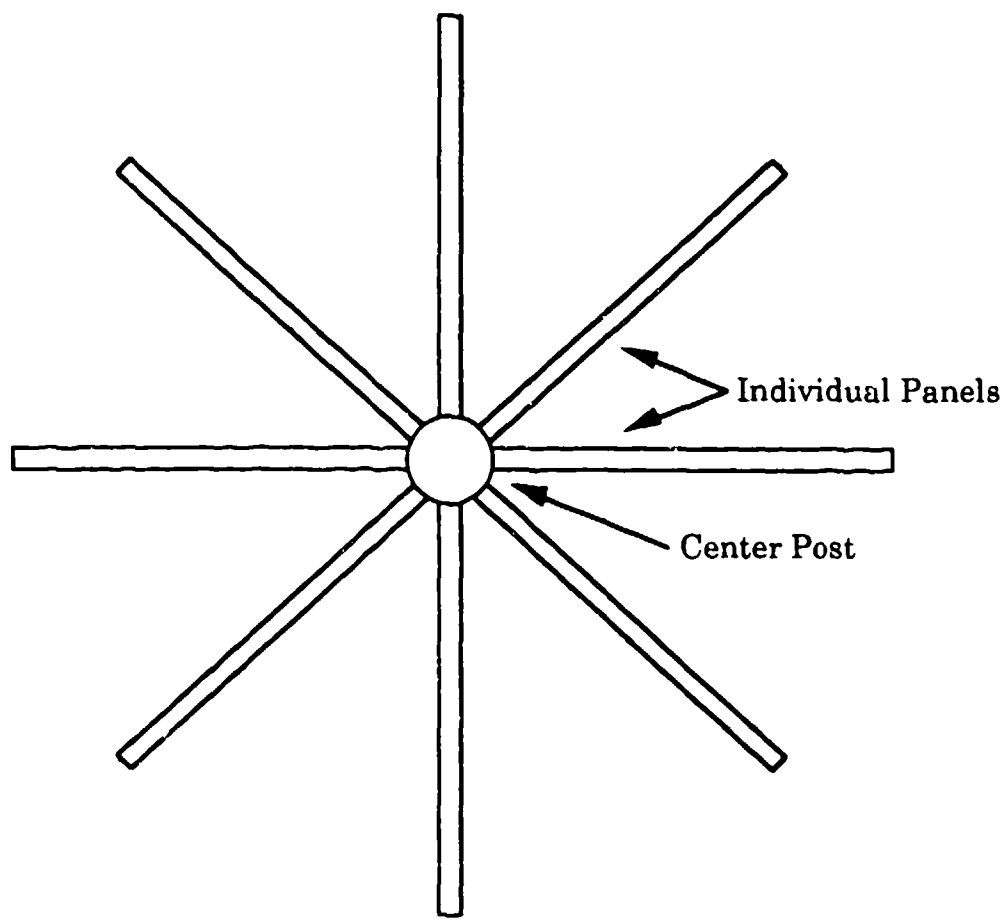
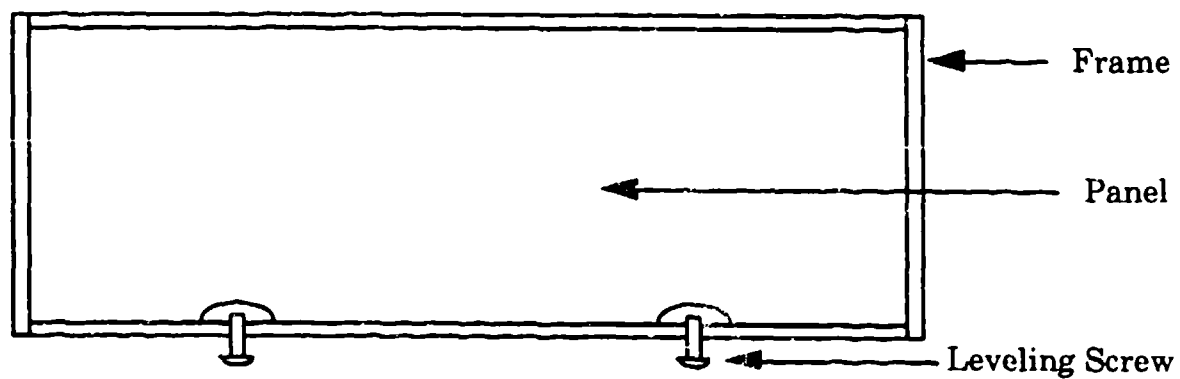

Figure 1. Details of plate construction showing the 8 petals.



TOP VIEW



SIDE VIEW OF INDIVIDUAL PANEL

Figure 2. Pedestal used to support circular, parallel-plate waveguides.

III. SLOTTED CYLINDER ANTENNA

Slotted Cylinder Antenna Considerations

Following preliminary antenna analysis and testing, the slotted cylinder emerged as the best feed antenna for the parallel plates. These antennas consist of hollow metal cylinders with rectangular slots cut along their axial dimensions [5,6]. The antennas have been most widely used in applications where horizontal polarization with an essentially constant amplitude horizontal pattern was required. Consequently, slotted-cylinder antennas have been used as radiators for frequency-modulated radio and ultra-high-frequency television broadcasting. A vertically-slotted-cylinder antenna fed, e.g., by a coaxial cable routed along the inside of the cylinder (as shown in Figure 3) will radiate a horizontally polarized field (i.e., the electric field vector propagates radially from the slot with an orientation which is perpendicular to the longitudinal axis of the slotted cylinder). The amplitude of this field in the horizontal plane is dependent on the cylinder diameter. In general, the radiated field amplitude tends to be greater on the cylinder side where the slot is located. However, when the cylinder diameter is sufficiently small (about one factor of magnitude) compared to the wavelength, the radiated field in the horizontal plane becomes essentially uniform. When the cylinder diameter becomes a significant part of a wavelength, the field in the region of the shadow cast by the cylinder becomes small. Generally, as the cylinder diameter becomes large, the horizontal field approximates a cardioid [7]. Slot width influences the capacitive loading of the antenna in much the same way as cylinder circumference influences inductive loading. When slot width is small relative to wavelength, the horizontal pattern is independent of the axial distribution of the field along the slot. For slotted cylinders, the effect of greater slot width is to increase the length of the slot required for resonance for a given cylinder diameter. Resonant length tends to become quite long as cylinder diameter becomes small, but decreases as the cylinder diameter increases. Thus, the interactive relationship between slot width, slot length, and cylinder diameter is evident.

A major concern in evaluating the slotted cylinder as a feed antenna for the circular, parallel-plate waveguide was input impedance. The impedance can be varied over a rather large range by changing the effective capacitance. For center-fed cylinders with diameters small relative to wavelength, the impedance at the first resonant point is rather high, with a range of 300 to 1,000 ohms. This impedance indicates that the feed should be a parallel-wire transmission line, perhaps with an inline balun. If cylinder diameter is appreciably increased, a second resonant point occurs, and it has an impedance of about 40 ohms. This impedance indicates that the feed should be a coaxial cable. These impedance values can be varied somewhat by feeding the antenna off center.

The bandwidth and radiation pattern were also considered in evaluating the slotted cylinder as the feed antenna for the circular, parallel-plate waveguide. Published information on bandwidth was almost nonexistent; however, reference

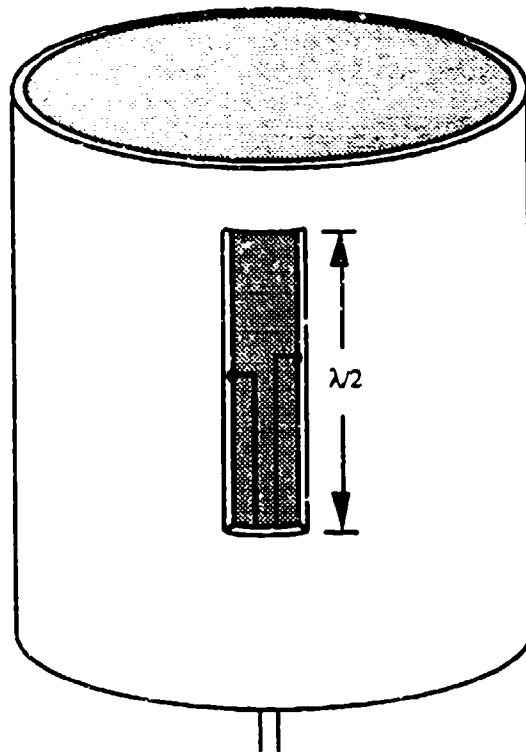

Figure 3. Slotted cylinder antenna

was made in one instance [6] to measurements that indicated bandwidths at the first resonance of between 4% and 8%. These measurements were made at frequencies where the standing wave ratio on the feed line was 2:1. Published information on radiation patterns was somewhat more available, but it involved theoretically derived, rather than experimentally measured, data. Theoretically derived patterns [7,8] showed essentially uniform amplitudes in the horizontal plane.

Extensive analysis of design and performance features of slotted-cylinder antennas lead to the design of such an antenna for use with a circular, parallel-plate waveguide. The primary design parameters and their final values were:

- D -- diameter of the cylinder 10 cm (4 in.),
- T -- thickness of the cylinder wall 0.312 cm (0.125 in.),
- L -- length of the slot 35.6 cm (14 in.),
- W -- width of the slot 0.312 cm (0.125 in.).

A commercially-available aluminum cylinder with a 10-cm (4 in.) diameter and a 0.312-cm (0.125 in.) wall thickness was obtained, and the desired slot was cut along its axial dimension. After construction of the circular, parallel-plate waveguide, this antenna was installed and performance evaluations were conducted.

Construction of the Slotted Cylinder Antenna

The slotted-cylinder antenna was constructed using a 2.44-m (8 ft) long, 10-cm (4 in.) diameter aluminum cylinder with a wall thickness of 0.3175 cm (0.125 in.). The cylinder was cut into four individual sections, two 76.2 cm (30 in.) long and two 45.7 cm (18 in.) long. Slots for the antenna were cut the desired length along the axial dimension of these sections. The two longer sections provided the feed antennas for the upper and lower pairs of plates within the waveguide assembly. For the upper antenna, 45.7 cm (18 in.) of the cylinder section was positioned between the two plates making up the top-most waveguide, and 30.5 cm (12 in.) extended above the upper plate to facilitate installation of the feed cables, baluns, and connectors. For the lower antenna, 45.7 cm (18 in.) of the cylinder section was positioned between the two plates making up the bottom waveguide, and 30.5 cm (12 in.) extended into a nylon insert in the center of the support pedestal. The two 45.6 cm (18 in.) long sections provided the feed antennas for the two internally located waveguides in the four-tier assembly.

Two individual sections of the slotted-cylinder antenna, joined by press-fitting nipples, are shown in Figure 4. Assembly of the antenna sections involved gently pressing one cylinder section onto the nipple of the lower antenna to achieve a tight fit. Each pair of cylinder sections was joined at the plane of the circular plates. To assure that there was no wave propagation inside the cylinder (and, therefore, no electrical interference between adjacent waveguides), the top of each nipple was sealed by a metal plate isolator. Holes were provided in the isolator to allow passage of transmission lines. The presence of nipple inserts inside the slotted-cylinder antenna altered the impedance somewhat; however, the baluns/transformers and tuning stubs were adjusted to compensate for this alteration.

Excitation of the slotted-cylinder antenna was accomplished by attaching twin-lead cables across the slots in each of the four antenna sections. The cables were routed from the ceiling of the radiation room down through the center of the aluminum cylinders. Attachment across the four slots required a mechanically strong connector capable of providing good electrical contact between the twin-lead cables and the slots. Also, it was important that the connectors not introduce excessive stray capacitance or inductance. The connectors provided for this purpose are shown in Figure 5. Construction of the connectors involved cutting sectorial sections out of Teflon block and mounting them across the slots with lat-

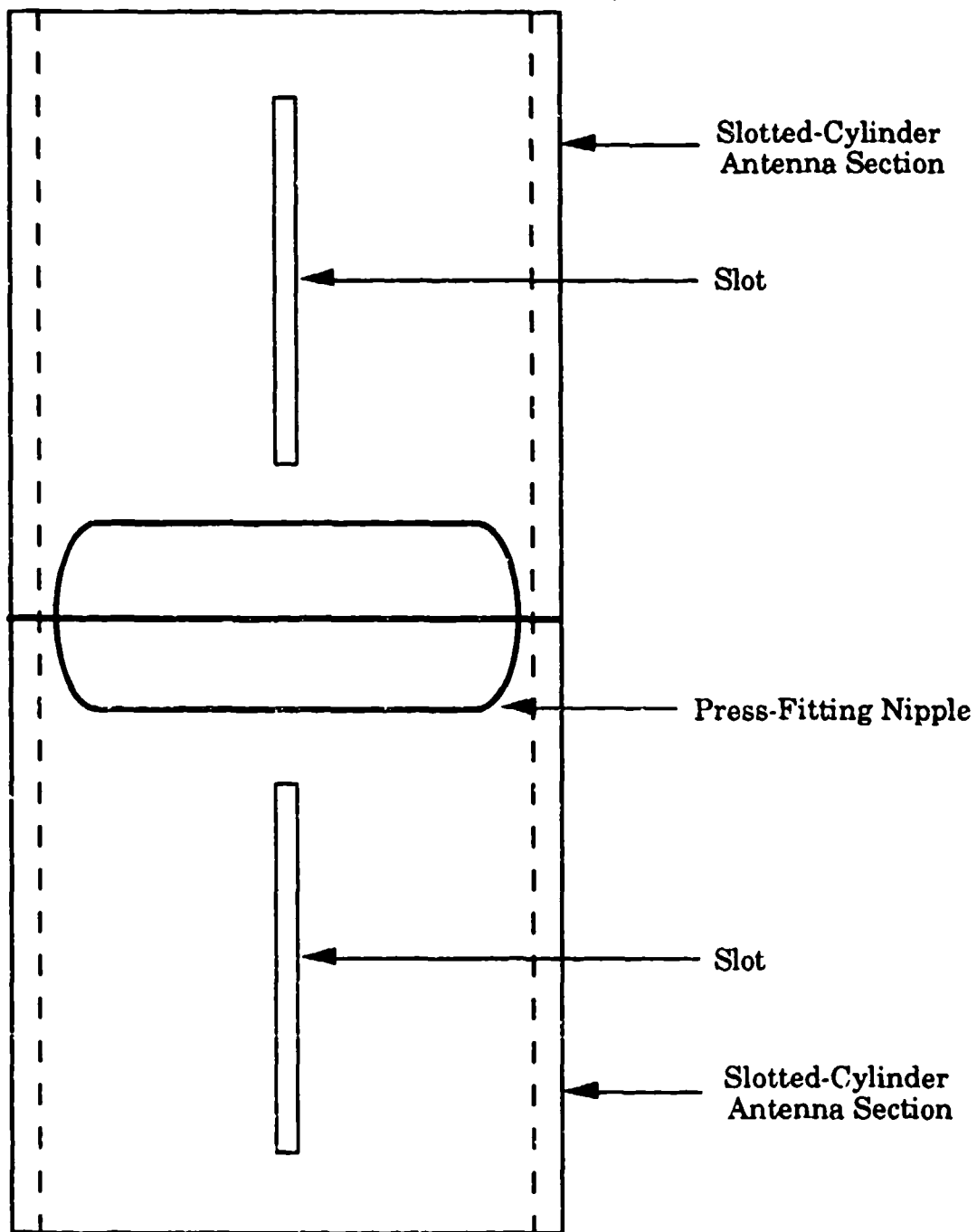

Figure 4. Technique used to assemble slotted-cylinder antenna.

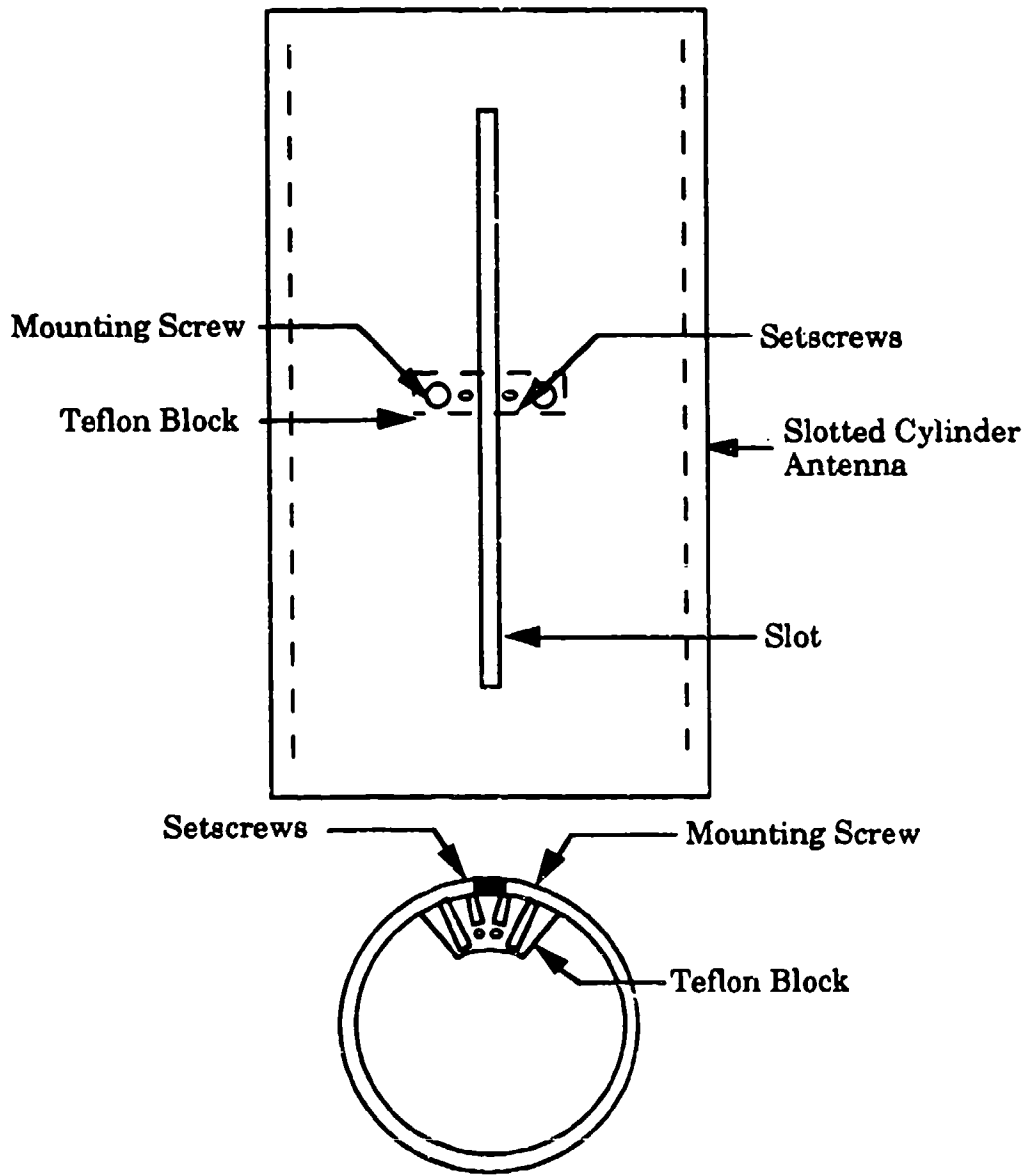

Figure 5. Technique used to mount cables to slotted-cylinder antenna.

head screws. Advantages of the Teflon material included its transparency to 435-MHz fields and its mechanical strength. Holes were drilled into the Teflon block to accept the twin-lead transmission lines from the baluns/transformers. Setscrews were then used to make the electrical connection between the cylinder walls and transmission lines.

IV. TRANSMITTER SYSTEM

The transmitter used to excite the slotted antenna was a Model R9DAT unit purchased from Microwave Control, Inc (MICON). The unit was capable of operating in either a pulsed-wave (PW) or continuous-wave (CW) mode at a fixed frequency of 435 MHz. Four separate outputs (one for each circular, parallel-plate waveguide) were provided on the unit top. The power level at all 4 outputs was adjustable by means of a single front panel control. In Mode 1, the transmitter provided a CW output of up to 200 W average at each of the four outputs. In Mode 2, a PW output of up to 5,000 W peak was provided at each of the four outputs. Other front panel controls allowed the pulse width to be varied from 0.25 to 10 μ s and the pulse repetition frequency to be varied from 1.0 to 5.0 kHz. Primary power was applied by the operation of circuit breakers on the front panels.

Transmitter Subassemblies

A photograph of the MICON Model R9DAT Transmitter is shown in Figure 6. The transmitter consisted of 8 major subassemblies mounted in a single equipment cabinet. The 8 subassemblies are illustrated in Figure 6, and from the top down, they are identified as:

- the Circulator Load Subassembly,
- the #1 and #2 Power Amplifier Subassembly,
- the #1 and #2 Driver Amplifier Subassembly,
- the System Control Subassembly,
- the Oscillator, Preamplifier, and Modulator Subassembly,
- the High Voltage Power Supply Subassembly for #1 and #2 Driver Amplifiers,
- the High Voltage Power Supply Subassembly for #1 Power Amplifier, and
- the High Voltage Power Supply Subassembly for #2 Power Amplifier.

Figure 7 shows an outline of the subassembly interconnections and a brief description of each subassembly is provided in the following paragraphs.

High Voltage Power Supply Subassemblies for #1 and #2 Power Amplifiers

These two identical subassemblies provided the high voltages necessary for the two output power amplifiers. Front panel controls on each subassembly included a main circuit breaker, status indicator lamps, and a current overload/reset switch. The power supplies contained an overcurrent monitoring circuit that prevented excessive current drain during operation. After any overcurrent situation had been corrected, the reset switch was momentarily actuated manually to resume operation. Each supply was cooled by a fan whose input was a screened opening on the front panel.

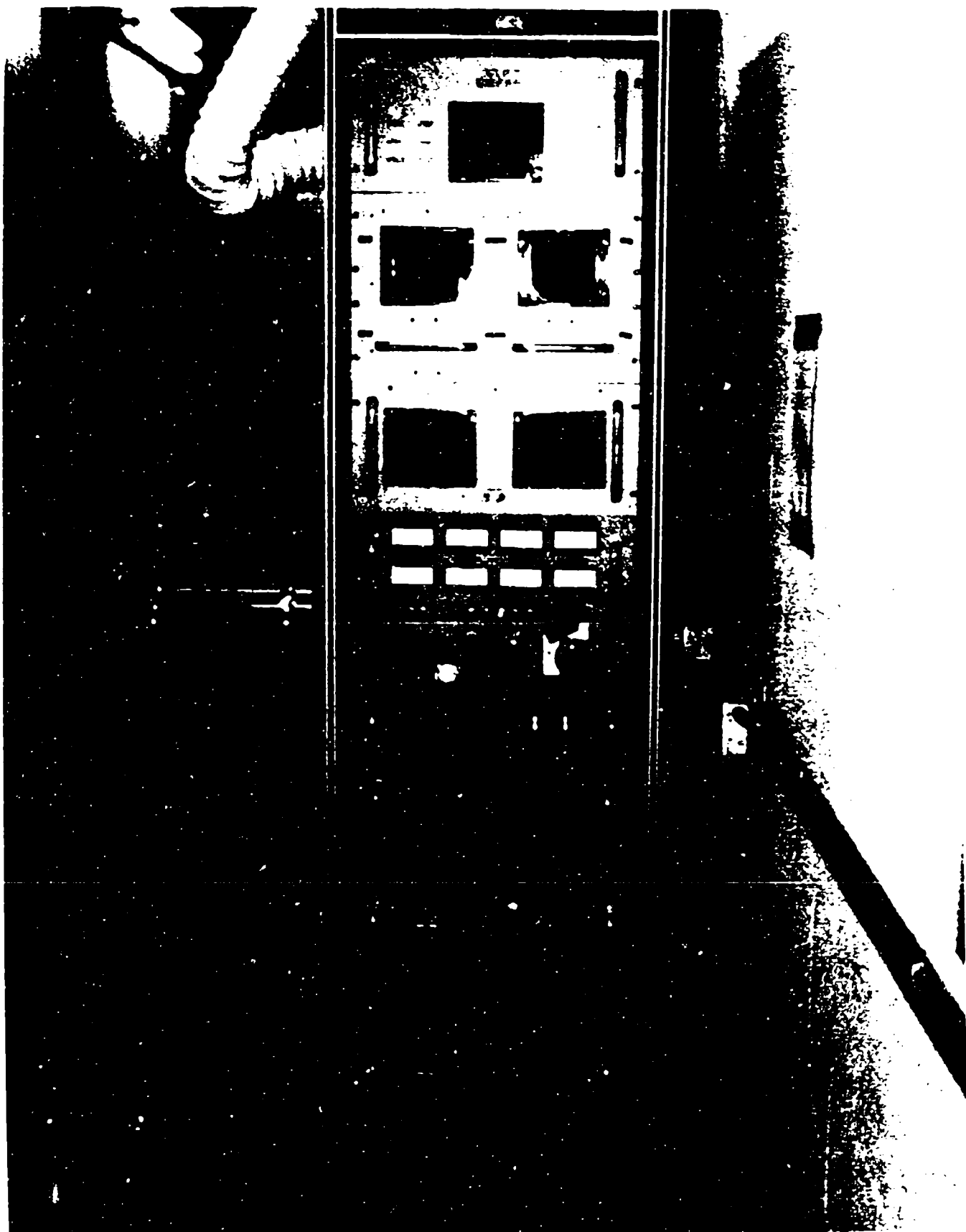

Figure 6. Photograph of MICON Model R9DAT Transmitter .

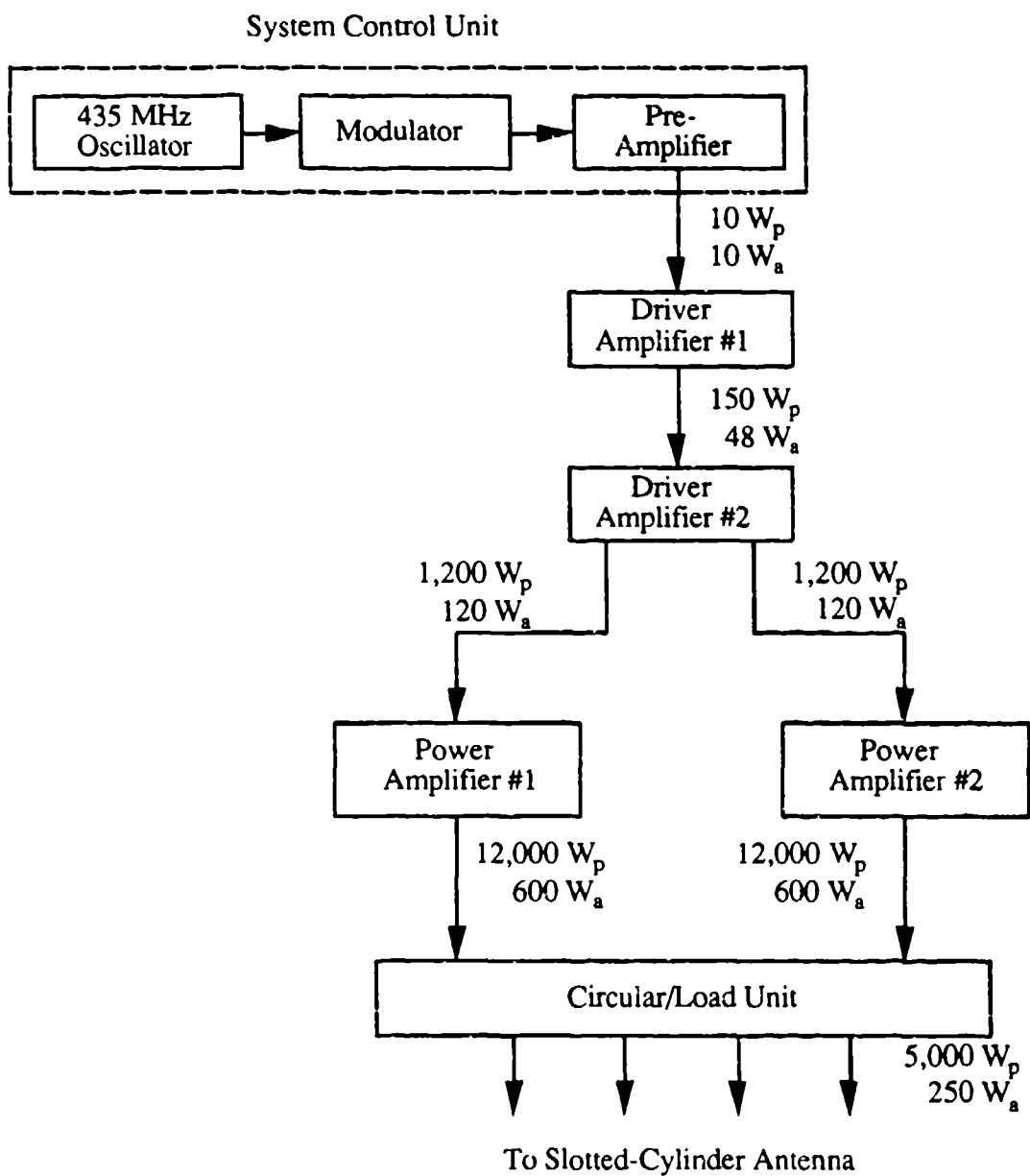

Figure 7. Block diagram of MICON Model R9DAT Transmitter.

High Voltage Power Supply Subassembly for #1 and #2 Driver Amplifiers

The high voltage power supply for both of the driver amplifiers was contained in this subassembly. Front panel controls included circuit breakers, status indicator lamps, an overcurrent/reset switch, and test points. The indicator lamps showed operate, standby, and overcurrent conditions for each power supply. A manual momentary actuation of the reset switch was necessary for operation of the power supplies after the cause of an overcurrent condition has been cleared. The test points monitor current provided by each supply, with 1.0 V corresponding to 100 mA of output current. Cooling for the subassembly was provided by a fan whose screened input was located in the front panel center.

Oscillator, Preamplifier, and Modulator Subassembly

The subassembly provided the solid-state devices and functions necessary to excite the driver amplifier subassembly. Three main controls were provided on the panel, two that enabled the operator to control pulse width and pulse repetition frequency, and a third that permitted either internal or external modulation to be selected. Two coaxial connections were available: one provided output synchronization pulses, and the other provided an input for external modulation. Under normal operations, the output of this subassembly was about 10 W average in either the PW or CW mode. Cooling was provided by a single fan whose screened input was located on the front panel.

System Control Subassembly

The subassembly, as its name implies, contained all of the controls necessary to run the Model R9DAT Transmitter in any of its modes. Eight meters (2 for each of the 4 RF outputs) provided a continuous indication of each radiofrequency (RF) output by displaying approximate forward and reflected power levels. For meters that indicated forward power, the full-scale reading was about 200 W and 5,000 W, respectively, in the CW and PW modes. Meters that indicated reflected power displayed a Voltage Standing Wave Ratio (VSWR) of 2:1 at full scale for both CW and PW operation. If any one of the four outputs presented a VSWR in excess of 2:1, a VSWR monitor automatically disabled all high voltage power supplies. Also, at the end of a 10-s period during which an excessive VSWR condition continued to exist, normally-open relay contacts operated to signal an external autodialer mechanism (not provided) to call assigned telephone numbers. Other controls on the front panel permitted the transmitter to be placed in either the standby or operate mode, and to be manually reset after any overcurrent condition. A switch that permitted selection of either CW or PW operation and a RF output control was also provided on the front panel. Indicator lamps on the front panel indicated the overall status of transmitter operation. A fault analyzer was also part of this subassembly, and de-energized the transmitter if preset conditions at selected monitored points were exceeded. Another set of contacts was provided in the subassembly to permit de-energizing of the transmitter if the RFR room was entered when radiation mode was activated. Operation of these contacts energized a Sonalert speaker in the subassembly, and a loud tone was emitted for about 2 min. At the end of 2 min,

the autodialer mechanism could be operated to call a designated sequence of telephone numbers. To reestablish normal operation, the monitor in the RFR room had to be reset and the reset switch on the system control subassembly momentarily actuated manually. An additional overcurrent protection monitor was provided in this subassembly to protect the transmitter from excessive current drain. Like the RFR room monitor, this overcurrent protection monitor operated the Sonalert speaker and de-energized the transmitter.

#1 and #2 Driver Amplifier Subassembly

The subassembly accepted the 10 W output of the oscillator, preamplifier, and modulator subassembly, directed it through two cascaded amplifiers and a two-way power splitter, and provided outputs for the power amplifier subassembly. At the output of the first driver amplifier, the power levels were about 48-W average and 150-W peak, respectively, for CW and PW operation. These power levels were amplified to about 275-W average for CW operation and 2,750-W peak for PW operation of the second driver amplifier. The output of the second driver amplifier was split such that CW and PW outputs of about 120 W average and 1,200-W peak were provided. Cooling for the subassembly was provided by two fans with screened openings for air input on the front panel.

#1 and #2 Power Amplifier Subassembly

The subassembly contained two identical high power cavity amplifiers that provided either CW or PW outputs for the circulator load subassembly. In the PW mode, the maximum output of the subassembly was 12 kW, which was divided by a two-way power splitter which provided in excess of 5-kW peak to each RF output. In the CW mode, the maximum output of the subassembly was 600-W average, which after routing through the two-way power splitter, provided in excess of 250-W average to each RF output. The cavity amplifiers were protected against overtemperature by sensors that de-energized all high voltage if the internal temperature exceeded 100°C. Overtemperature lamps that indicated an overtemperature condition were provided on the front panel. Each cavity amplifier had a cooling fan, and screened openings for air input to these fans were on the front panel.

Circulator Load Subassembly

Output power from the power amplifier subassembly was split, monitored, and interfaced with the RF outputs of the transmitter by this subassembly. The power splitting was accomplished in high power, two-way splitters that accepted the two outputs from the power amplifiers and provided four outputs. Each of these outputs was routed through a circulator that provided protection against unacceptable changes in load conditions. The circulators provided sampling ports that permitted the monitoring of forward and reflected power for each output (8 monitors). Signals from these 8 monitors were accessible on the front panels through eight coaxial connectors. The output level of these signals ranged from 0 to +10 dBm for forward power. Reflected power monitoring was based on a

2:1 VSWR which, if exceeded, de-energized all high voltage power supplies. The subassembly was air cooled through a screened opening in the front panel.

Besides the 8 major subassemblies, the transmitter required interconnecting cables. These cables were provided in the equipment cabinet and interconnected the various subassemblies into connectors on the back of individual chassis. Each cable and connector was color-coded to expedite the interconnection of chassis and, where proper, like connectors were keyed to avoid erroneous connections.

The overall performance specifications for the MICON Model R9DAT Transmitter are summarized in Table 1.

TABLE 1. OVERALL PERFORMANCE SPECIFICATIONS FOR MICON MODEL R9DAT TRANSMITTER

Frequency	435 MHz
Power output:	
Mode 1, CW, each of 4 outputs	200 W
Mode 2, PW, each of 4 outputs	5,000 W
RF power balance (output-to-output)	± 0.5 dB
Pulse rise time	0.12 μ s max.
Pulse fall time	0.2 μ s max.
Pulse width	0.25-10 μ s
Pulse repetition frequency (PRF)	1-5 kHz
RF power adjustment	Max. to -6 dB
Synchronous output	+5 V at 50 ohms

The subassemblies and cabling just described defined the major operational and performance capabilities of the MICON Model R9DAT Transmitter; however, there was an additional important capability provided by a device external to the cabinet-mounted subassemblies shown in Figure 6. This capability involved a MICON Model 01A-28-0005 power combiner that accepted as inputs the four circulator/load unit outputs on the cabinet top, and provided a single output with PW and CW power levels of 16 kW_{peak} and 800 W_{average}, respectively. The single output could be connected to one of the slotted-cylinder antennas to provide an exposure power density in excess of 10 mW/cm² for a single waveguide. In constructing the circular, parallel-plate facility, the third-level slotted-cylinder antenna was provided with high power cables capable of handling the 16 kW_{peak} and 800 W_{average} power levels.

V. ANALYSIS OF THE ANTENNA, DISTRIBUTION, AND PARALLEL PLATE SYSTEMS

During the third part of the program [3], a prototype version of the antenna, distribution, and waveguide systems was analyzed in sufficient detail to clearly indicate the feasibility of this radiation facility concept. A final battery of analyses was performed to characterize the performance of these systems in their final installation. The antenna, distribution, and parallel-plate systems consisted of the following components:

- a four-tier assembly of circular, parallel-plate waveguides,
- the antennas that excited a particular mode of electromagnetic wave propagation,
- the transmission lines required to feed the antennas,
- the impedance matching and current balancing networks in the transmission lines, and
- the connectors/isolating devices for cabling.

The experimental animals were to be positioned around the circular plate circumference and would be expected to spend most of their time with their long axes parallel to the waveguide's parallel plates. To achieve maximal coupling to the experimental animals, the electric field vector had to be parallel to the animals' long dimensions; therefore, a TE_{10} propagation mode was required for the parallel-plate radiators. For this propagation mode, the horizontal electric field exhibited a half-cosine distribution, with the peak midway between each pair of plates. The horizontal electric field distribution was analyzed by comparing a linear electric field distribution, expressed as $E_1 = E_{01}$, where E_{01} was a constant, to a TE_{10} electric field, expressed as $E_2 = E_{02} \cos(\pi z/2d)$, where E_{02} was a constant, $2d$ was the plate separation, and z was the vertical displacement ($z = 0$ midway between plates). The squares of these quantities multiplied by a scaling factor (the inverse of the waveguide impedance Z_g) yielded the power density. For equal linear and cosine distribution power levels, the following equality could be made:

$$\frac{1}{Z_g} \int_{-d}^d E_{01}^2 dz = \frac{1}{Z_g} \int_{-d}^d E_{02}^2 \left(\cos \frac{\pi z}{2d}\right)^2 dz, \quad (3)$$

which then yielded

$$\frac{E_{02}^2}{Z_g} = \frac{2E_{01}^2}{Z_g}. \quad (4)$$

Thus, it was clear that midway between each set of plates ($z = 0$) and for equal input power levels, the cosine distribution caused the power density to be twice the value for a linear distribution.

The impedance Z_g for the TE_{10} mode wave propagation is given by

$$Z_g = \frac{\eta}{\sqrt{1 - \left(\frac{f_c}{f}\right)^2}}, \quad (5)$$

where

- η = the intrinsic impedance of the medium between the parallel plates,
- f = the operating frequency of the parallel-plate radiator, and
- f_c = the cutoff frequency of the radiator (328 MHz for a 45.7-cm (18 in.) plate separation distance).

The impedance of a set of parallel plates operating at 435 MHz in the TE_{10} mode with a 45.7-cm (18 in.) separation distance was 574 ohms. The radiator could be analyzed as radiating into free space; therefore, the normalized reflected power $|\rho|^2$ was determined to be

$$|\rho|^2 = \left(\frac{574 - 377}{574 + 377}\right)^2 = 0.04. \quad (6)$$

The equation indicated that 4% of the incident power would be reflected, and this level was considered quite acceptable for a long-term, low-level radiation facility.

The effect of experimental animals (rodents) on waveguide impedance was analyzed by modeling the rodents as parallel dielectric slabs within a parallel-plate capacitor. The combination of rodents and parallel plates yielded a composite dielectric constant (parallel capacitors model). This modeling approach yielded results that were approximate, but the effort involved was much more consistent with the scope of this program than would have been the case if an exact solution had been sought. Assuming an array of 25 rodents, each approximately 17.8 cm (7 in.) long, with a dielectric constant of 49, and separated center-to-center by 45.7 cm (18 in.), the effective relative dielectric constant of the array was determined to be 1.61. The waveguide impedance became 452 ohms, thereby causing 1.4% of the incident power to be reflected. This low level of reflected power was very attractive.

Analyses also showed that the waveguide with its 45.7-cm (18 in.) plate separation distance could support TM and TEM propagation modes if they were excited. Consequently, care had to be exercised to assure that they were not excited. Impedance values for the TE_{10} and TEM propagation modes were

determined to be 248 ohms and 327 ohms, respectively. To excite only the TE₁₀ mode, the slotted-cylinder antenna described in Section III was selected as the feed for the circular, parallel-plate waveguide. The antenna developed an electric field across the narrow dimension of the slot, thereby generating a radiation field polarized horizontally with respect to the parallel plates of the waveguide. The impedance of the 36.83-cm (14.5 in.) slotted-cylinder antenna, when center fed with a balanced transmission line, varied from 700 to 1,400 ohms depending on the transmission line and nipples within the line. As a result, the antenna was well matched to the waveguide impedance.

Analysis efforts also indicated that each pair of plates in the tier assembly should be electrically isolated from the other pairs of plates. Without this isolation, electrical interference phenomena could distort propagated fields and result in the different waveguides generating different exposure fields. The circular, parallel plates located internal to the tier assembly were part of two different waveguides: the upper plate surface for one waveguide and the lower surface of the same plate for another waveguide. To determine the extent to which the waveguides were electrically isolated, skin depth calculations were made using the following expression [9];

$$\delta = \frac{1}{sR_s}, \quad (7)$$

where

- δ = skin depth in meters,
- s = conductivity in siemens/m, and
- R_s = surface resistivity in ohms/m²

For aluminum, s is 3.72×10^7 and R_s is $3.26 \times 10^{-7} \sqrt{f}$, where f is the frequency in Hertz. At 435 MHz, the skin depth was computed to be 3.95×10^{-6} m (1.6×10^{-4} in.). This value was orders of magnitude less than the thickness of any aluminum sheet that would be used to construct the four-tier assembly of circular, parallel plates; therefore, each pair of plates was well isolated from the others.

A possible source of power dissipation in the exposure facility that required analysis before finalizing the design was attenuation inside the parallel plates. The waveguide attenuation/unit length (α) for the TE₁₀ mode was given by

$$\alpha = \frac{2R_s f_c^2}{\eta a f^2 \sqrt{1 - \left(\frac{f_c}{f}\right)^2}}, \quad (8)$$

where a is the plate separation distance and the other terms are as previously defined [9]. The attenuation was calculated to be 1.735×10^{-6} nepers/2.54 cm (1 in.) or 1.5066×10^{-5} dB/2.54 cm (1 in.). Thus, over a plate radius of 182.9 cm (72 in.), the signal would be attenuated only 1.08×10^{-3} dB. Therefore, essentially no signal would be lost due to attenuation in the waveguide.

Proper functioning of the slotted-cylinder antenna required that it be fed with balanced currents at a high impedance. Devices used for impedance transformation and current balancing had to be compact since they were to be located inside the 10-cm (4 in.) cylinder that formed the antenna. Also, these devices had to be capable of handling high peak and average power levels. The impedance transforming balun shown in Figure 8 was developed to meet this criterion. The balun ideally consisted of a piece of coaxial transmission line with two quarter-wavelength slots milled into it at locations 180° displaced from each other. At the end of the slotted coaxial cable, the center conductor, which had been extended to become one lead in a twin-lead transmission line, was shortened to one half of the outer conductor by means of a shorting post. The other half of the outer conductor was electrically connected to a lead that had the same diameter as the center conductor. The lead, and the center conductor, then formed the twin-lead transmission line with a characteristic impedance of 250 ohms. The twin-lead transmission line was deliberately maintained less than one-tenth wavelength to limit its impedance transforming characteristics and minimize the possibility of undesired stray radiation. Since the twin-lead conductors were electrically separated through the balun by a half wavelength, they were 180° out of phase, and therefore balanced.

In the analysis of impedance transforming baluns, it was noted that the ideal balun may be modeled as two 100-ohm transmission lines in parallel and connected to a coaxial line as shown in Figure 8. One of the two 100-ohm lines was terminated in a short circuit while the other was terminated in a load (ultimately the antenna). If the length L of each 100-ohm transmission line is one-quarter wavelength, the impedance at their junction with the coaxial cable can be determined. In this case, the short circuit transforms to an open at the junction and the load Z_L transforms back to become

$$Z_T = \frac{(100)^2}{Z_L} . \quad (9)$$

For a matched system, $Z_T = 50$ ohms, so Z_L must be 200 ohms. This value was somewhat low and did not provide a good match to the slotted-cylinder antenna. However, if the slot lengths in the balun coaxial cable were shortened slightly by means of metal adjusting devices (see Figure 8), the currents were kept nearly balanced while the impedance necessary for the best match could be adjusted markedly. This procedure was used to coarse tune the slotted-cylinder antenna.

It was necessary for the exposure facility to function properly with reasonably high levels of average and peak powers. Specifically, three of the parallel plate waveguides had to accommodate 200 W of average power and 5 kW of peak power. The fourth parallel plate waveguide had to accommodate 800 W of average power and 20 kW of peak power. Average power limitations were determined by power levels capable of causing thermal destruction of conductors or, more commonly, thermal destruction of dielectrics. Peak power limitations were determined by power levels capable of causing dielectric breakdown (arcing). Analysis efforts noted that a dry air dielectric is excellent for high average powers

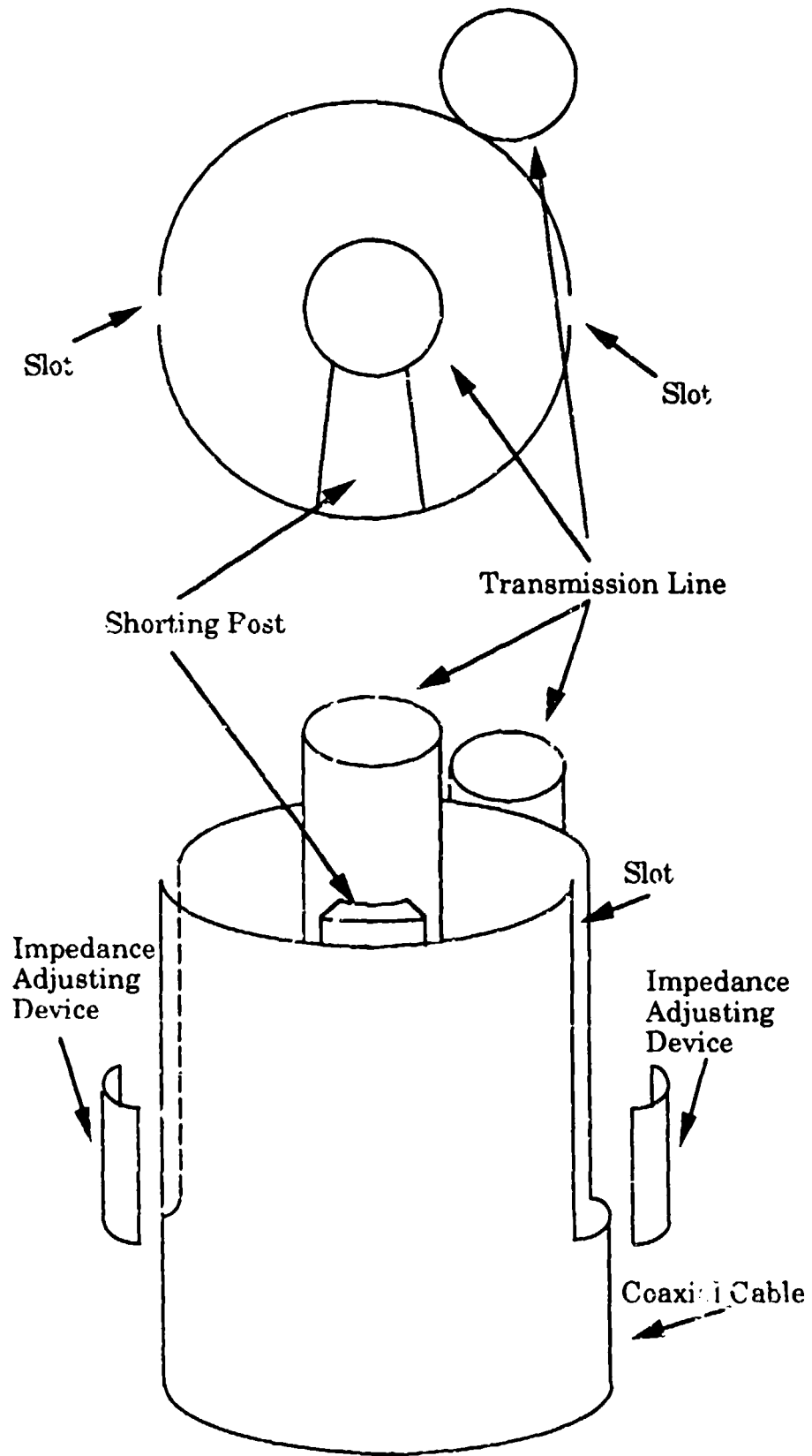

Figure 8. Diagram of impedance transforming balun.

since it is essentially lossless, but relatively poor dielectric breakdown properties limit its peak power capabilities. Coaxial cables filled with a polyethylene foam dielectric were chosen for the transmission lines since they exhibited superior peak and average power characteristics. These cables tolerate the highest average powers anticipated with a voltage standing wave ratio of 4.0 without exceeding their power ratings. The impedance transforming baluns had the same power ratings as these cables.

The slotted-cylinder antenna was analyzed to determine its peak power rating. Dry air experiences electrical breakdown under an electric field strength of 30,000 V/cm. The antenna slot was 0.312-cm (0.125 in.) wide. Thus, voltages in excess of 9,525 V would be necessary to cause air in the slot to break down. In a conservative analysis, it was assumed that the potential at the center of the slot was 1.414 times the potential that would have been present if the electric field was uniformly distributed, rather than cosine distributed, along the slot. Under these circumstances, the peak power rating of the slot was determined to be 32.4 kW. Since the cylinder impedance was usually closer to 700 ohms, a more likely peak power rating was 64.8 kW. Both ratings far exceed the power levels the slots had to withstand.

An eighth-wavelength dipole [10] antenna was used to map horizontal and vertical components of the electric field along the edge of each pair of parallel plates. The purpose of this mapping was to assure that all experimental animals would be exposed to the same environment and the waveguides were operating in the TE_{10} mode. Measurements of the horizontal field component were also made to establish the existence of a cosine field distribution between the plates of each waveguide.

The horizontal component of the field was found to vary by ± 1 dB peak-to-peak around the circumference of the plates. The vertical field electric component was 17 dB down from the horizontal component, thereby confirming TE propagation. The horizontal field component was found to exhibit a half-cosine variation between the plates, and this established the propagation mode as TE_{10} . The exposure fields of each waveguide were probed to determine whether any interference was distorting the propagated fields. The electric field structure was found to be essentially identical for each set of plates and interference distortion was not observed. The measured exposure field values for each waveguide are shown in Figures 9 and 10.

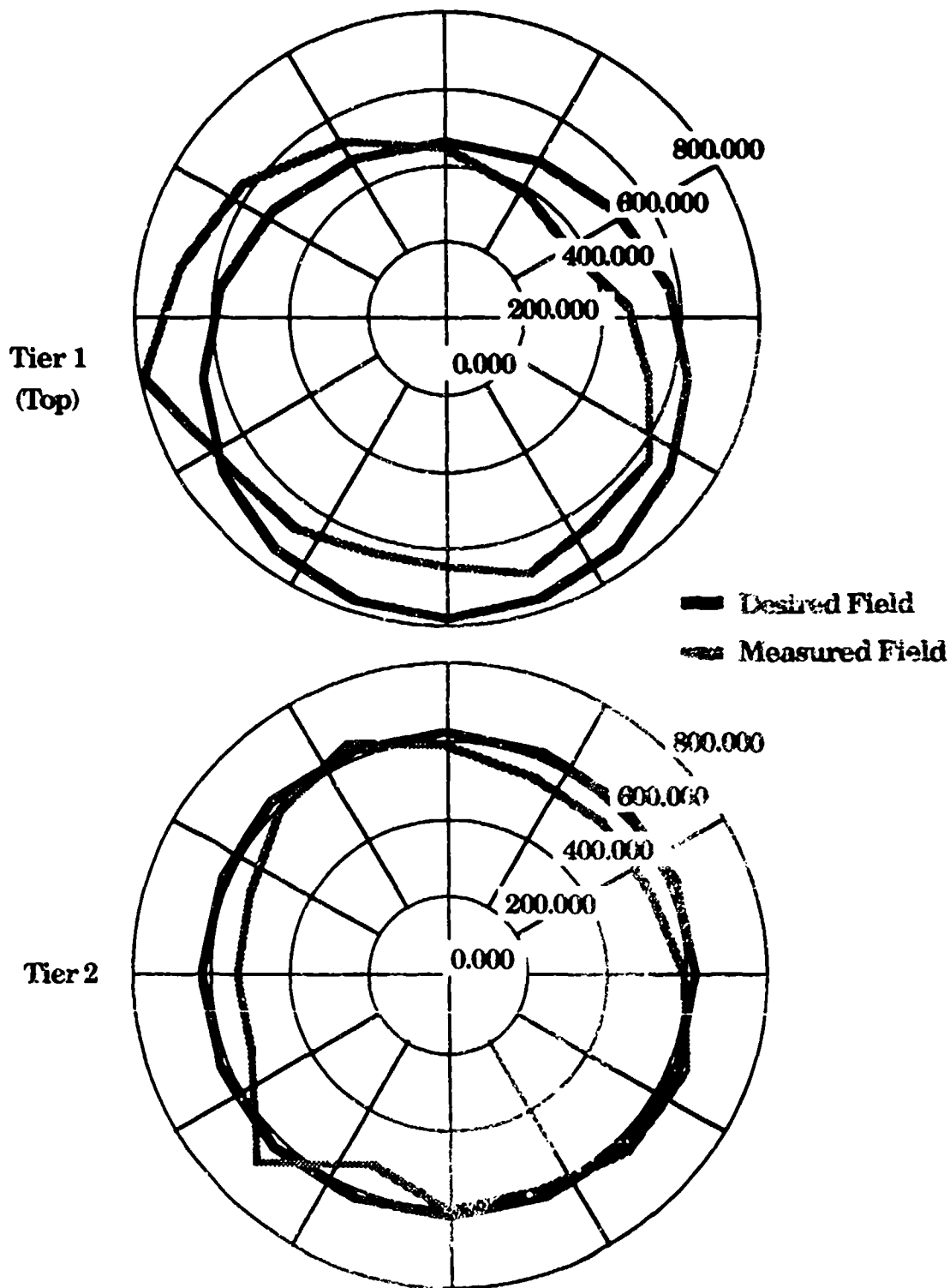

Figure 9. Measured field patterns for tier 1 and tier 2 of the parallel-plate waveguide exposure system.

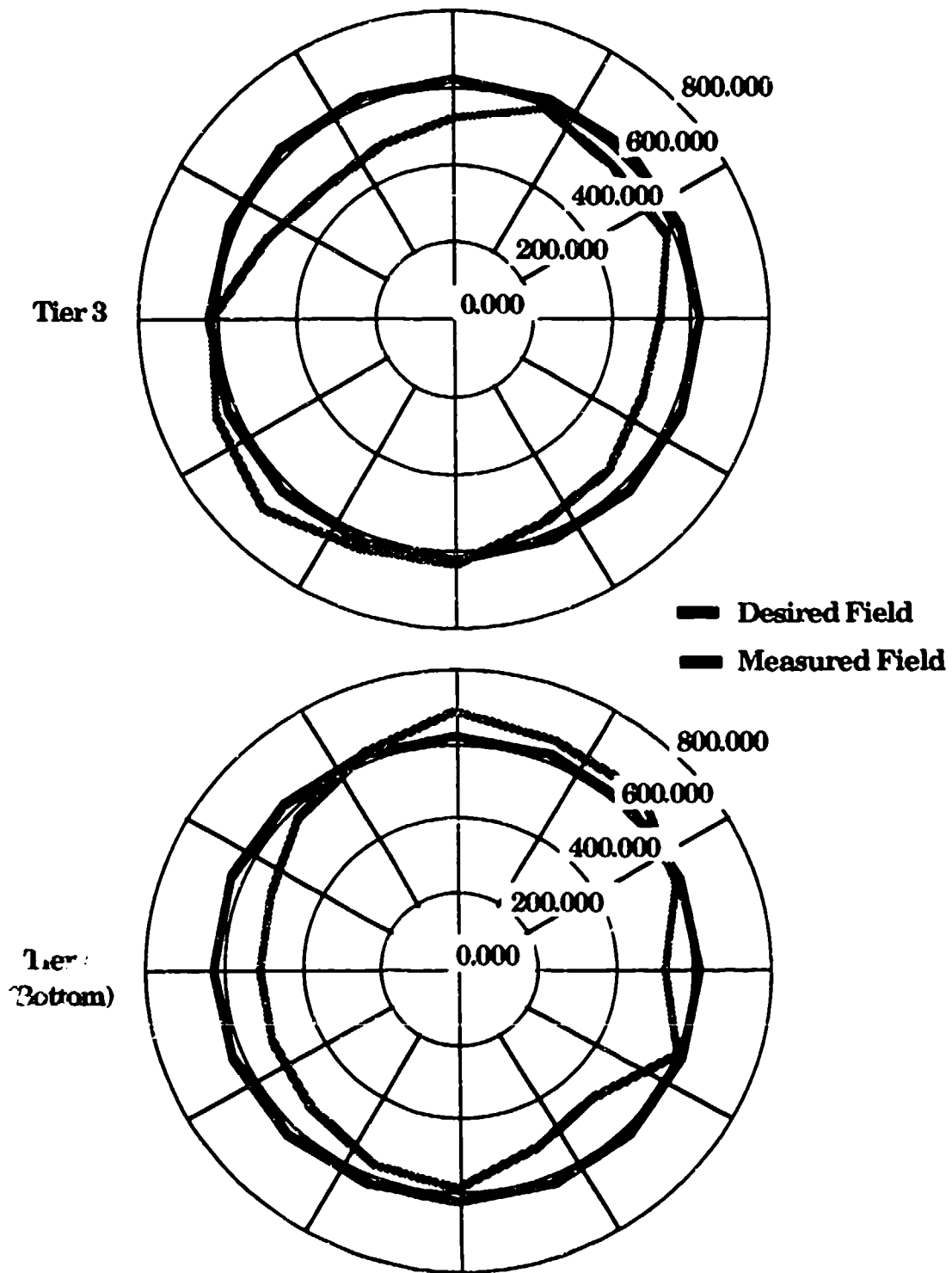

Figure 10. Measured field patterns for tier 3 and tier 4 of the parallel-plate waveguide exposure system.

VI. CAGE CONSIDERATIONS

Cage design and spacing are extremely important, and often overlooked, considerations in bioeffects studies that involve experimental animals exposed to electromagnetic waves. The importance of cage design stems from the fact that it establishes the physical environment for the animal throughout the exposure duration; therefore, it is both a dominant factor in the animal's well-being during exposure and an influencing factor in experimental results [11]. Cage-to-cage spacing is important because scattered waves from the cage, the animal, or both could introduce uncertainties in dosimetry determinations. The exact extent to which cage design and spacing influence a given study depend on a variety of subjective and objective considerations that interact differently from one study to the next; however, for all studies, it is mandatory that animal cages be designed and positioned with sufficient care to assure that they do not introduce artifactual responses in the study results.

Cage Design Considerations

For this study, the importance of exposure cages was especially critical since the animals were to be housed in the cages for an extended time. Therefore, cage design had to be thoroughly considered from the point-of-view of both physical environment and experimental results. Overall, it was important that the cage design:

- involve materials that were visibly transparent to permit easy determination of animal status, electromagnetically transparent to reduce intercage scattering to tolerable levels, and structurally sufficient to provide long-term housing,
- use dimensions that yield a total exposure area as small as possible, and
- provide adequate means for ventilation and cleanliness.

From a physical comfort point-of-view, the primary design considerations were cage dimensions, ventilation, and sanitation. Cage dimensions were important because they governed not only freedom of movement and postural adjustments, but they also influenced the area required in the exposure zone. To define cage dimensions, it was noted that mouse cages advertised in catalogs typically offered a floor area of about 206 cm² (32 in.²) and a height of 13 cm (5.12 in.). These dimensions were compared with space guidelines for adult mice (greater than 25 g) as recommended by the National Institutes of Health [12]. These guidelines specify a minimum floor area of 96.78 cm² (15 in.²) and a cage height of about 12.7 cm (5 in.). After reviewing various cage designs and discussing this subject with knowledgeable animal caretakers and veterinarians, the decision was made to use commercially available Nalgene Transparent Polycarbonate cages with a floor area of 206 cm² (32 in.²). These cages were structurally adequate for housing a mouse throughout the 21-month study duration. The dimensions were over two times that required in the National Institutes of Health guidelines and allowed 55 cages, with adequate spacing, to be arrayed around the circumference of each waveguide.

Cage ventilation was important because of the necessity of keeping reasonably constant environmental conditions and promoting animal comfort. Environmental conditions of concern were temperature, humidity, and air movement. Since ambient air ventilated the cages, it was necessary for the design of the cage top to provide easy entrance and exit of room air. Consequently, the cage tops selected were Nalgene filter covers that used a transparent polyvinyl chloride (PVC) body to support a paper filter insert. An additional Plexiglas slotted insert was fixed inside each filter top to prevent the animals from chewing through the filter paper and possibly escaping. The slotted openings in the Plexiglas provided sufficient air circulation for adequate cage ventilation. The cage tops were secured to the cage body with the aid of removable rubberbands.

The final cage design consideration for physical comfort was the choice of bedding. Since the Nalgene cage body was not designed to allow feces and urine to pass through the floor of the cage, the bedding had to absorb urine as well as remove undesired odors. In addition, the bedding could not cause perturbations in the exposure field. In view of these considerations, the cage bedding chosen was Cellu-Dry, a pelletized organic cellulose fiber (Shepard Specialty Papers Inc., Kalamazoo, Michigan).

Water for animals in the cages was provided by individual water bottles. These bottles used glass rather than metal sipper tubes to minimize field perturbations that could affect power exposure and absorption [12]. Custom-designed Plexiglas water bottle holders were constructed to hold the water bottle inside the cage. Since water bottles for cages used with the circular parallel-plate radiation facility could use glass sipper tubes and also be oriented perpendicular to the exposure field, minimal perturbations associated with water provisions occurred at the 435-MHz exposure frequency.

To test the exposure environment, fifty-five cages with bedding, food, filter tops, and filled water bottles were placed on each waveguide. Power measurements were performed using a small dipole, Hewlett Packard 8481A power sensor, and Hewlett Packard 436A power meter. The dipole was placed inside a cage and the waveguides were energized. The measured values were then compared to the values obtained with no cages present on the waveguide. No detectable change in power meter reading was observed at 435 MHz. This test also indicated that the cage separation distance necessary to place fifty-five cages on each waveguide did not produce any noticeable field scattering at the frequency of interest. To position the animals midway between the parallel plates, cages were placed on Styrofoam spacers of the appropriated height. The final cage design was as shown in Figure 11.

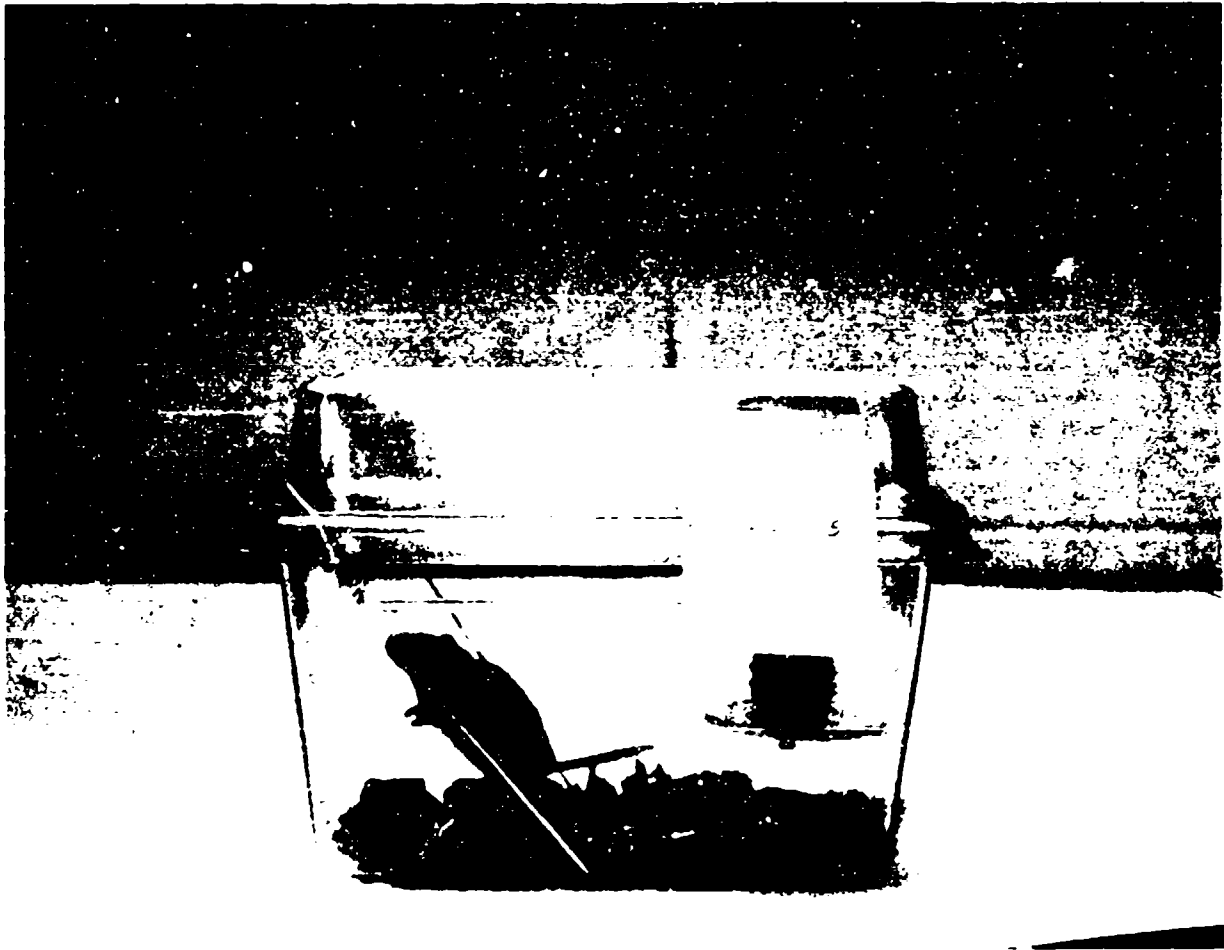

Figure 11. Final cage design.

VII. CAGE WASHER SYSTEM

After reviewing the technical specifications, cost, and size of cage washers from several manufacturers, the Southern Cross Model 900-A Dyna Jet Washer was purchased and installed in Room D of the RFR Facility (Figure 12). The washer was constructed of stainless-steel and provided fully automatic wash, rinse, and final rinse cycles for all types of animal cages and accessories. A tempered safety-glass viewing window was installed in the washer front. Loading of the washer was done from the left (soil) side, through a guillotine, pass-through door with a safety interlock feature that prevented washer operation until the door was closed. Exit was on the right (clean) side, through a pass-through door identical to the one on the entry side. Cage washing was provided by water jets from motor-driven, rotating, stainless-steel manifolds above and below the wash compartment. A 133 liter (35 gal) detergent tank below the wash compartment was used for the wash cycle. This tank contained a heavy-duty heating element with an external control, which allowed the wash water temperature to be varied from room temperature up to 87.8°C (190°F). The rinse cycle used hot tap water from the building utility supply. For final rinse, a 102.6 liter (27 gal) tank with an automatic water-level controller was provided. External plumbing provided the introduction of special final rinse fluids (distilled water, deionized water, etc.) and disinfectants.

Automatic reset timers controlled the wash and rinse time intervals as follows:

Wash Cycle:	0 to 10 min
Rinse Cycle:	0 to 10 min
Final Rinse Cycle:	0 to 1 min

These timers were wired so that any cycle could be omitted by adjusting the cycle timer to the "off" position. After the timers had been set to the desired cycle durations, the start button was pushed and the wash/rinse operation was automatically continued through all cycles.

To facilitate wash and rinse operations, special-purpose stainless-steel racks were provided for the Polycarbonate cages and glass water bottles. Each of these racks held 6 cages and 49 bottles, respectively, in the wash compartment of the washer. The bottle rack provided a cover of stainless-steel mesh to prevent water jets in the washer bottom from forcing bottles out of the rack during wash and rinse cycles. The glass sipper tubes, with corresponding rubber stoppers, were cleaned manually using a soap water solution and a small test tube brush. Following washing, the glass tubes and stoppers were thoroughly rinsed. The cleaned water bottles and sipper tubes were then covered with a clean cloth until they were used the following day.

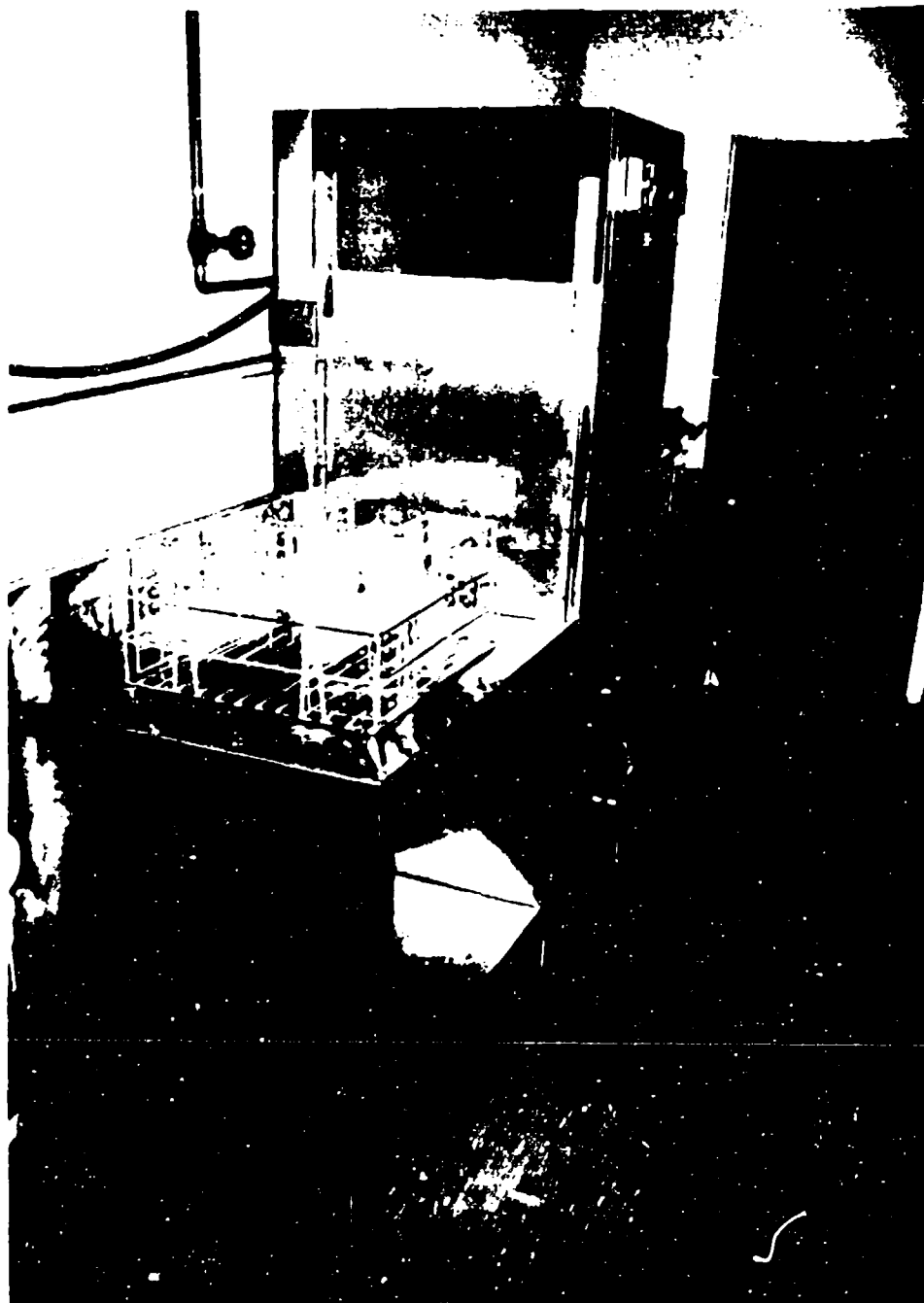

Figure 12. Cage washer.

VIII. DATA ACQUISITION SYSTEM

The long-term nature of this project dictated that a data acquisition/processing system would be desirable for electronically storing experimental data. The stored data would be in a format that could easily be reviewed throughout the study as well as be compatible with data analysis software packages. In particular, the system had to:

- automate the data logging procedures,
- perform basic statistical analysis of the experimental data,
- allow data export to other analysis systems and storage media,
- organize the data set for best interpretation, and
- monitor the data entry and provide alert of any detected entry errors.

To implement such a system, a Zenith Sportport Laptop 286 microprocessor-based computer and supporting software were purchased. The Zenith computer contained a 20 megabyte hard drive that provided enough storage capacity to store relevant software and the complete study data set. LOTUS 123, a widely used spreadsheet software package, Data Addition and Verification Entry (D.A.V.E.), a software package compatible with LOTUS 123, and LOTUS MEASURE, a software package compatible with LOTUS 123 that allowed communications across a standard RS232 port, were purchased to execute the data acquisition, user interface, and data entry into the system. LOTUS 123 allowed a set of commands to be stored and executed as a set of macros. D.A.V.E. was used by the LOTUS 123 software to set up user menus and gain information relative to how data were to be stored in the spreadsheet. The acquisition program was designed to perform the following task:

- calibrate the electronic balance,
- allow manual entry of animal information, and
- automate a weighing scheme and weight data storage.

IX. ELECTRONIC BALANCE SYSTEM

An electronic balance capable of communicating with the data acquisition system was necessary for acquiring and storing mouse weight data. After reviewing technical capabilities of balances from several manufacturers, the Sartorius Model IP-65 Balance with built-in microprocessor, variable integration time, and locked-in readout was purchased. The balance offered a weighing range and readability of 0 to 4,000 g and 0.001 g, respectively. The Model IP-65 had the capability to communicate with external hardware via a RS232 port. This capability was used to link the balance to a computer's RS232 port to interactively perform designated functions automatically. The electronic balance system was used to accurately weigh mice and automatically store the weight data in a specified file on the connected computer. The programmed weighing scheme weighed the animals ten times over a 1-s interval and stored the average of these weights in the designated computer file. Figure 13 is a photograph of the electronic balance and data acquisition system.

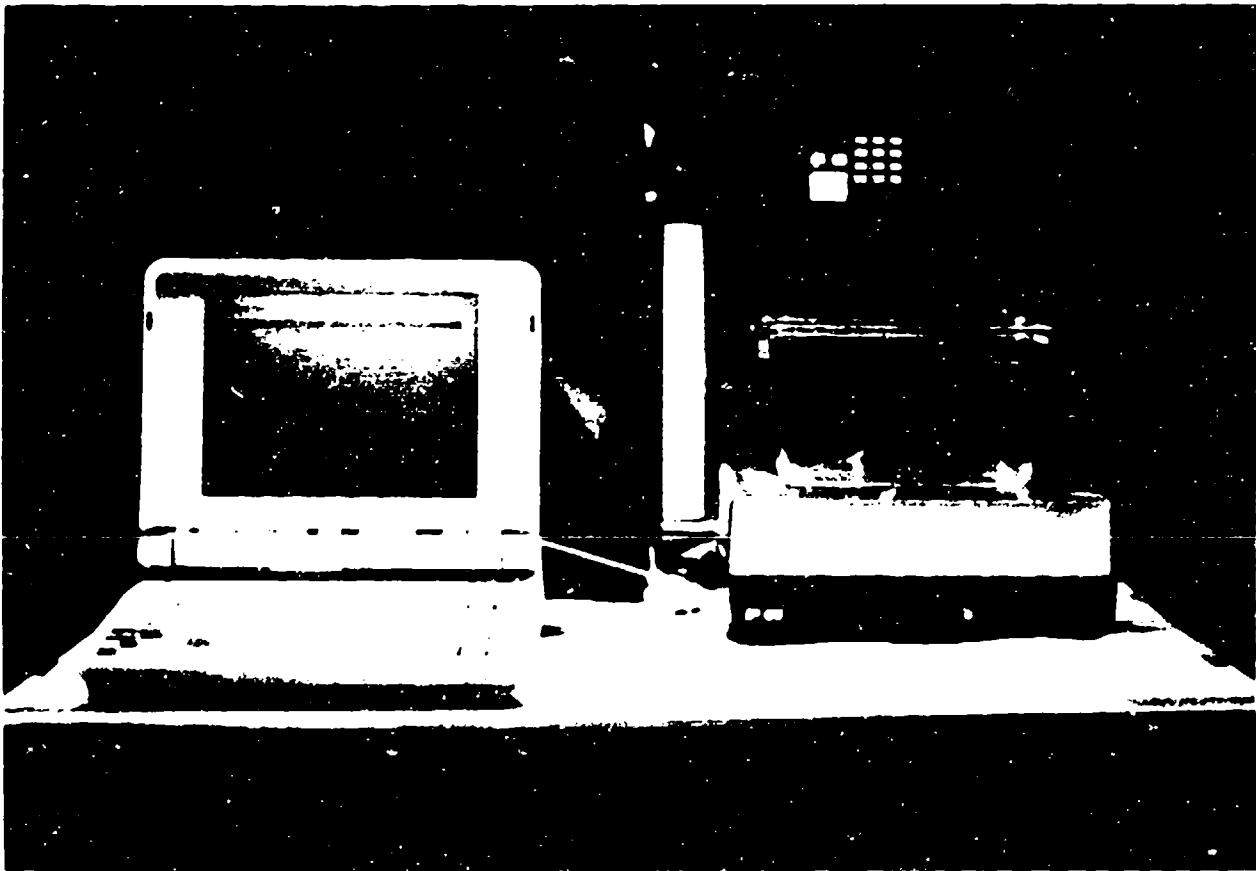

Figure 13. Electronic balance/data acquisition system.

X. OVERALL FACILITY DESCRIPTION

The overall facility for long-term exposure of large rodent populations to 435-MHz PW and CW environments consisted of:

- (1) a four-tier assembly of circular, parallel-plate waveguides located in the radiation room, the walls of which were lined with microwave absorbing material,
- (2) an identical four-tier assembly of circular, parallel-plate waveguides located in the control room, the walls of which were also lined with microwave absorbing material,
- (3) a 435-MHz transmitter capable of either PW or CW operation that provided 4 outputs, each with 200 W average and 5.0 kW peak power,
- (4) 450 Polycarbonate cages that individually housed mice for the duration of the study,
- (5) a room that housed the transmitter and its auxiliary equipment,
- (6) a room that housed devices needed for assay of biological endpoints,
- (7) a room that housed a cage washer/dryer,
- (8) a room that housed a computer-based data management system,
- (9) a room that stored food, cages, detergents, disinfectants, and other supplies, and
- (10) a buffer area that isolated the control and radiation rooms from other activity in the building.

The cages, transmitter, and circular, parallel-plate waveguides have been described in previous sections of this report. In this section, the rooms for housing the facility are described.

The overall layout of the RFR facility is shown in Figure 14. The total facility occupied about 185.8 m² (2000 ft²) in Rooms 19 and 19A (basement level, northeast corner) of the Baker Building on the Georgia Tech main campus. The identification of each room in Figure 14 and its size are as follows:

<u>Room Purpose</u>	<u>Room Size</u>
Radiation room	7.01 x 7.01 m (23 x 23 ft)
Control room	7.01 x 7.01 m (23 x 23 ft)
Transmitter room	1.83 x 7.01 m (6 x 23 ft)
Buffer room	2.13 x 15.24 m (7 x 50 ft)
Computer room	3.04 x 3.04 m (10 x 10 ft)
Assay room	2.74 x 3.04 m (9 x 10 ft)
Clean-up room	2.74 x 3.04 m (9 x 10 ft)
Storage room	2.74 x 3.04 m (9 x 10 ft)

The microwave absorbing material that lined the walls of the radiation and control rooms was purchased from Advanced Absorber, Inc., and had a height of 45.7 cm (18 in.). At 500 MHz, the specified reflectivity of this material was -30 dB. The material was mounted to the walls using Velcro hook and eye material. Strips of hook material were glued in appropriate locations to the sheetrock walls

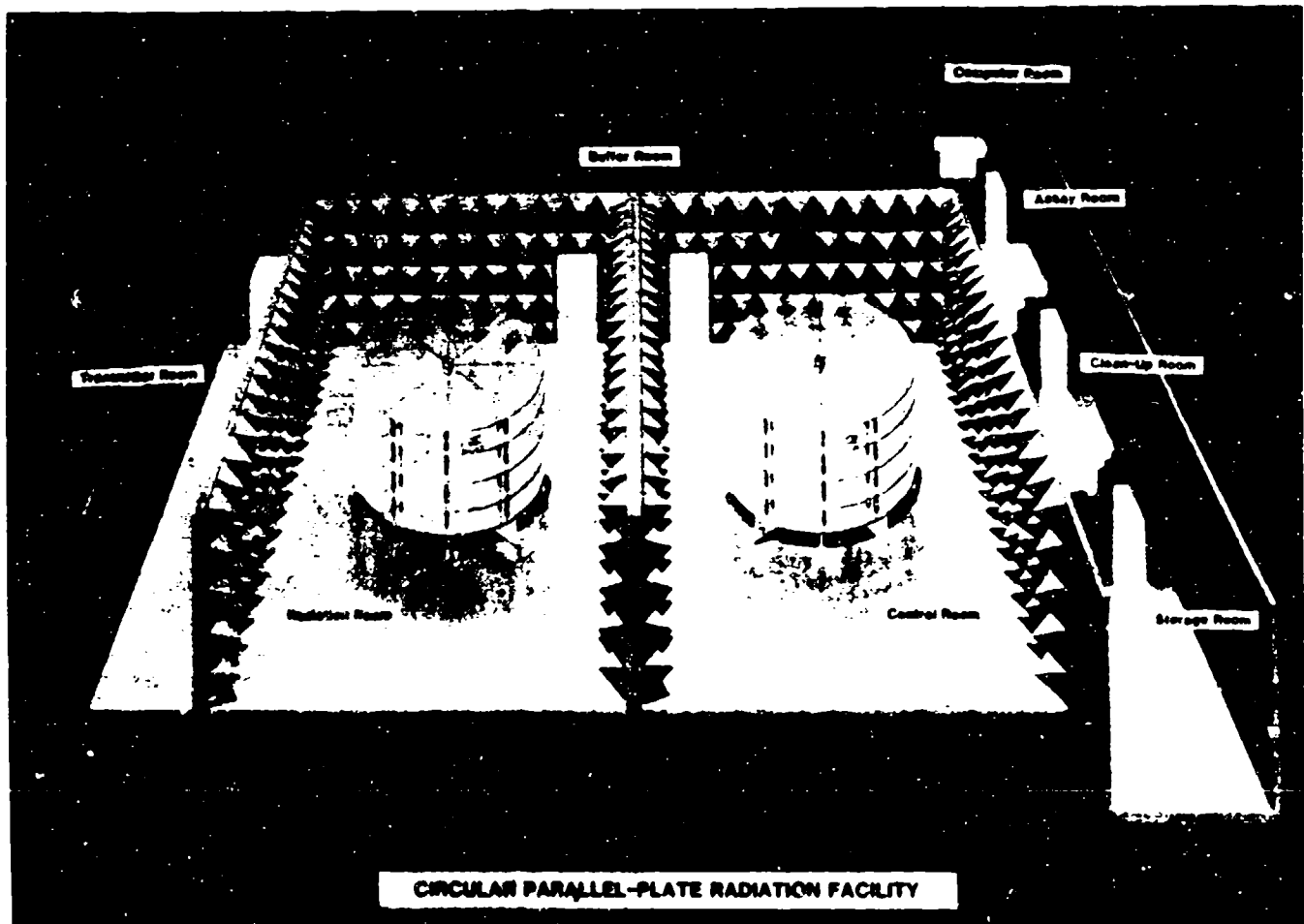

Figure 14. Overall layout of the RFR facility.

of the radiation and control rooms using contact cement. Similarly, strips of eye material were glued in appropriate locations to the absorbing material using contact cement. This approach made it possible to remove the absorbing material without tearing apart the individual blocks. All rooms making up the RFR facility were heated and/or cooled by an air-conditioning system isolated from the system used by the remainder of the Baker Building. Since the facility was located in a corner area of the Baker Building, two of its perimeter walls were outside walls; therefore, vents for the heating and cooling system were easily exhausted to outside air. This site was important for odor control and helped assure a disease-free mouse colony. Lighting for the radiation and control rooms was powered by an automatic timer with a manual over-ride capability. The timer was used to cycle the lighting on a 8 AM - 8 PM schedule. The control for this timer was at the entry to the rooms. Temperature in these rooms was maintained between 21.1°C and 23.3°C (70°F and 74°F) with minimum deviation. Sheetrock used to construct the perimeter walls for the radiation and control rooms was aluminum-backed, thereby providing a layer of foil shielding to reduce radiation leakage from the radiation room. No extensive amount of shielding was necessary to control leakage radiation since these perimeter walls were lined with the microwave absorbing material. The common wall between the radiation and control rooms provided a double layer of foil shielding because aluminum-backed sheetrock was mounted to both sides of the studs for this wall. Shielding continuity between adjoining pieces of sheetrock was maintained by overlaying the aluminum foil from one piece of sheetrock to the next, then taping the seam with electrically-conductive aluminum tape. Ceilings for the radiation and control rooms consisted of 0.61 m x 0.61 m (2 ft x 2 ft) panels of acoustic tile suspended in a grid of T-supports. Each of these panels was covered with a layer of aluminum foil to reduce any radiation that might leak into office areas on the first floor level of the Baker Building. Again, no extensive amount of shielding was considered necessary since the circular, parallel-plate waveguides directed their radiation outward, not upward.

In the cage washer room, a 10-cm (4 in.) soil stack was provided as a drain for the cage washer. Also, 208 V, 3-phase power was available in this area for the cage washer. In the transmitter room, 208 V, 3-phase power was available for the transmitter. Dual receptacle outlets for 60 Hz, 115 V power were available in all rooms, including the radiation and control rooms, where the outlets were located behind the microwave absorbing materials.

XI. ANIMAL IDENTIFICATION PROCEDURE

Each mouse had to be identifiable for the duration of the study. Several methods of identification commonly used in animal studies were investigated. For this study, 450 unique codes were required and the identification method had to be permanent. Given these requirements, the identification procedure implemented was an approved toe clip coding scheme. The procedure was conducted under methoxyflurane general anesthesia to minimize any possible trauma to the mice.

The 450 unique toe clip codes were provided by clipping a maximum of one toe on each foot. The lateral four toes on each foot were used for clipping, yielding five potential unique toe clip codes per foot (none clipped, lateral clipped, second lateral clipped, third lateral clipped, fourth lateral clipped). For all four feet, this yielded a total of $5 \times 5 \times 5 \times 5$, or 625 possible unique codes. Eliminating the single no-clip-on-any-foot possibility resulted in a total of 624 potential codes. The identification number was assigned to the toe clip of a single foot as follows:

0	=	No toes clipped,
1	=	Fourth lateral toe clipped,
2	=	Third lateral toe clipped,
3	=	Second lateral toe clipped,
4	=	First lateral toe clipped.

The numbers according to each foot's code were arranged in the order of

RF	=	Right fore,
LF	=	Left fore,
RR	=	Right rear, and
LR	=	Left rear.

This procedure yielded a unique four-digit code for each mouse and could be easily read and interpreted throughout the study. A detailed description of the toe clip procedure was provided in the Standard Operating Procedures documentation.

XII. REFERENCES

1. J. C. Toler, S. J. Bonasera, "Definition of Procedure to Study Bioeffects of Radiofrequency Radiation on Cell Growth and Differentiation," Georgia Tech Final Report on Project A-3529-270, May 1987.
2. J. C. Toler, R. L. Seaman, R. C. Johnson, and F. L. Cain, "Feasibility Study to Determine Design and Construction Criteria for a 420-to-450 MHz Chronic RFR Exposure Facility for Rats," Georgia Tech Final Report on Project A-2228, Subcontract No. SCEEE ARB/78-3, July 1979.
3. J. C. Toler, D. J. Freedman, and R. C. Johnson, "Prototype Circular, Parallel Plate Facility for Chronically Exposing Large Rodent Populations to 420-450 MHz Radiofrequency Radiation," Georgia Tech Final Report on Project A-2392, Subcontract ARB/79-20, January 1980.
4. S. A. Oliva and G. N. Catravas, "A Multiple-Animal Array for Equal Power Density Microwave Radiation," IEEE Trans. on MTT, pp. 433-436, May 1977.
5. A. Blumlein, High Frequency Electrical Conductor or Radiator. U.S. Patent No. 2,238,770, April 15, 1941.
6. E. C. Jordan and W. Miller, "Slotted Cylinder Antenna," Electronics, pp. 90-93, February 1947.
7. G. Sinclair, "The Patterns of a Slotted Cylinder Antenna," Proc. of IRE, pp. 1487-1492, December 1948.
8. J. R. Wait, "Radiation Characteristics of Axial Slots on a Conducting Cylinder," Wireless Engineer, pp. 316-323, December 1955.
9. S. Ramo, J. R. Whinnery, and T. Van Duzer, *Fields and Waves in Communication Electronics*, John Wiley, New York, 1967.
10. H. I. Bassen, et al., "A Miniature Broadband Electric Field Probe," Ann NY Aca Sci, 247:481-486 (1975).
11. "Responsibility for Care and Use of Animals," NIH Guide for Grants and Contracts, Vol. 7, No. 17, November 10, 1978, p. 1.
12. "Guide for the Care and Use of Laboratory Animals," DHQP Publication No. (NIH) 78-23, Revised 1978, pp. 34-35.